

23

# CEX-62.6.1

CIVIL EFFECTS STUDY

GALVESTON AREA (ARMS-II)

R. B. Guillou

**DISTRIBUTION STATEMENT A**  
Approved for Public Release  
Distribution Unlimited

20050916 253

Issuance Date: January 15, 1963

**CIVIL EFFECTS TEST OPERATIONS**  
**U.S. ATOMIC ENERGY COMMISSION**

## NOTICE

This report is published in the interest of providing information which may prove of value to the reader in his study of effects data derived principally from nuclear weapons tests and from experiments designed to duplicate various characteristics of nuclear weapons.

This document is based on information available at the time of preparation which may have subsequently been expanded and re-evaluated. Also, in preparing this report for publication, some classified material may have been removed. Users are cautioned to avoid interpretations and conclusions based on unknown or incomplete data.

PRINTED IN USA

Price \$0.30. Available from the Office of  
Technical Services, Department of Commerce,  
Washington 25, D. C.

# GALVESTON AREA (ARMS-II)

By  
R. B. Guillou

Approved by: L. J. DEAL  
Acting Chief  
Civil Effects Branch

Edgerton, Germeshausen & Grier, Inc.  
Santa Barbara, California  
June 26, 1962

## ABSTRACT

An Aerial Radiological Measuring Survey (ARMS) of the Galveston area was made for the Civil Effects Test Operations, Division of Biology and Medicine, U. S. Atomic Energy Commission, by Edgerton, Germeshausen & Grier, Inc., between Jan. 27 and Feb. 17, 1962. The survey was part of a nationwide program to measure present environmental levels of gamma radiation. Approximately 4400 traverse miles were flown, at an altitude of 500 ft above the ground, in the area that consists of the land portion of a 100-mile square centered on Galveston, Tex. The EG&G ARMS-II instrumentation was used in the survey.

The data are presented as aeroradioactivity units, or areas with similar gamma radiation rates at 500 ft, at two map scales: (1) generalized at about 1:1,000,000 and (2) detailed at 1:250,000. The aeroradioactivity in the area is less than 800 counts/sec, and in much of the area, the radioactivity is less than 400 counts/sec.

Aerial measurements of ground radioactivity in the ARMS-II Galveston area were consistent everywhere with what was expected, considering the geology of the area. Most of the area has a low radioactivity, and the surficial materials are mostly Quaternary clays, silts, and sand, which are, in general, weakly radioactive. The western part of the area along the Brazos River is slightly more radioactive than the rest of the area. Artificial radionuclides are probably present in only small quantities because the maximum background gamma radioactivity in many places is less than 200 counts/sec.

## CONTENTS

ABSTRACT . . . . .	5
1 INTRODUCTION . . . . .	9
1.1 Location of Area . . . . .	9
1.2 Purpose of Survey . . . . .	9
1.3 Air-borne Survey Procedure . . . . .	9
1.4 Instrumentation . . . . .	12
2 THEORETICAL CONSIDERATIONS OF ARMS DATA . . . . .	14
2.1 Sources of Gamma Rays . . . . .	14
2.2 Effect of Meteorological Conditions on the Gamma-ray Flux from Terrestrial Sources . . . . .	15
2.3 Conversion of Count Rate to Dose Rate . . . . .	15
3 AERORADIOACTIVITY DATA . . . . .	16
3.1 Interpretation and Compilation . . . . .	16
3.2 Presentation of Aeroradioactivity Data . . . . .	17
3.2.1 Generalized Aeroradioactivity Data . . . . .	17
3.2.2 Detailed Aeroradioactivity Data . . . . .	17
4 CORRELATION OF AERORADIOACTIVITY UNITS . . . . .	17
4.1 Correlation of Aeroradioactivity Units with Geology . . . . .	20
4.2 Correlation of Aeroradioactivity Units with Other Sources . . . . .	20
5 SUMMARY AND CONCLUSIONS . . . . .	20
REFERENCES . . . . .	20

## ILLUSTRATIONS

### FIGURES

1 Index Map Showing Location of ARMS-II Galveston Area and Adjacent ARMS Areas . . . . .	10
2 Civil Effects Test Operations ARMS Program . . . . .	11
3 Diagram of EG&G ARMS-II Instrumentation . . . . .	13
4 Aeroradioactivity Data and Units . . . . .	17
5 Generalized Aeroradioactivity Map of the ARMS-II Galveston Area . . . . .	19

# ILLUSTRATIONS (Continued)

## PLATES

1	East Part . . . . .	In pocket
2	West Part . . . . .	In pocket
3	South Part . . . . .	In pocket

## TABLE

1	K <sup>40</sup> , Thorium, and Uranium in Igneous and Sedimentary Rocks . . . . .	15
---	---	----

# GALVESTON AREA (ARMS-II)

## 1 INTRODUCTION

### 1.1 Location of Area

An Aerial Radiological Measuring Survey (ARMS) of the Galveston area was made for the Civil Effects Test Operations (CETO), Division of Biology and Medicine, U. S. Atomic Energy Commission, by Edgerton, Germeshausen & Grier, Inc. (EG&G), between Jan. 27 and Feb. 17, 1962. The area surveyed, which includes the land portions of a 100-mile square centered on Galveston, Tex., lies between 94°00' and 95°37' West longitude and between the Gulf of Mexico and 30°03' North latitude (Fig. 1). The eastern parts of the ARMS-I Hockley and ARMS-I Matagorda areas, which were surveyed in 1960 by the U. S. Geological Survey, and the cities of Houston, Bay Town, Texas City, Galveston, and Freeport were included in the area.

### 1.2 Purpose of Survey

The ARMS-II Galveston area survey was one of many that have been flown for the CETO since the nationwide ARMS program was started (1958). Figure 2 shows the location of the areas that have been surveyed to date. The purpose of the program is to measure the present environmental levels of gamma radiation in areas around nuclear facilities and planned nuclear activities. It is desirable to document the environmental radiation, which results primarily from the natural radioactivity of the surface soil and rock, to establish a base line or environmental datum. ARMS data from selected areas, in conjunction with data from resurveys of these areas, can be used to appraise changes in environmental levels of radiation brought about by debris from nuclear weapons testing programs, operation of nuclear facilities, and radiation accidents. The data are also important for understanding the long-term biological effects of low-level radiation.

### 1.3 Air-borne Survey Procedure

Topographic maps for the ARMS-II Galveston area were laid out, and the boundaries of the area were determined. Flight lines were drawn in an east-west direction, and a spacing of 1 mile between flight lines was used.

Ground check points were then selected along the flight lines and at the ends of the flight lines so that aircraft-position information obtained along the flight path could be correlated with the maps of the area.

The survey flights in the Galveston area were conducted between Jan. 27 and Feb. 17, 1962. About 4400 traverse miles were flown.

The daily flight procedure included equipment-stabilization time and in-flight calibrations on the radiation-detection apparatus. As soon as the aircraft was air-borne, the equipment was turned on and was allowed to reach temperature equilibrium. When thermal stabilization of the circuitry was reached, the radiation apparatus was calibrated with a Cs<sup>137</sup> source. Measurements of air-borne, cosmic, and extraneous radiation were then taken at 3000 ft above terrain. After arriving at the initial survey line for the day, the aircraft descended to the 500-ft survey

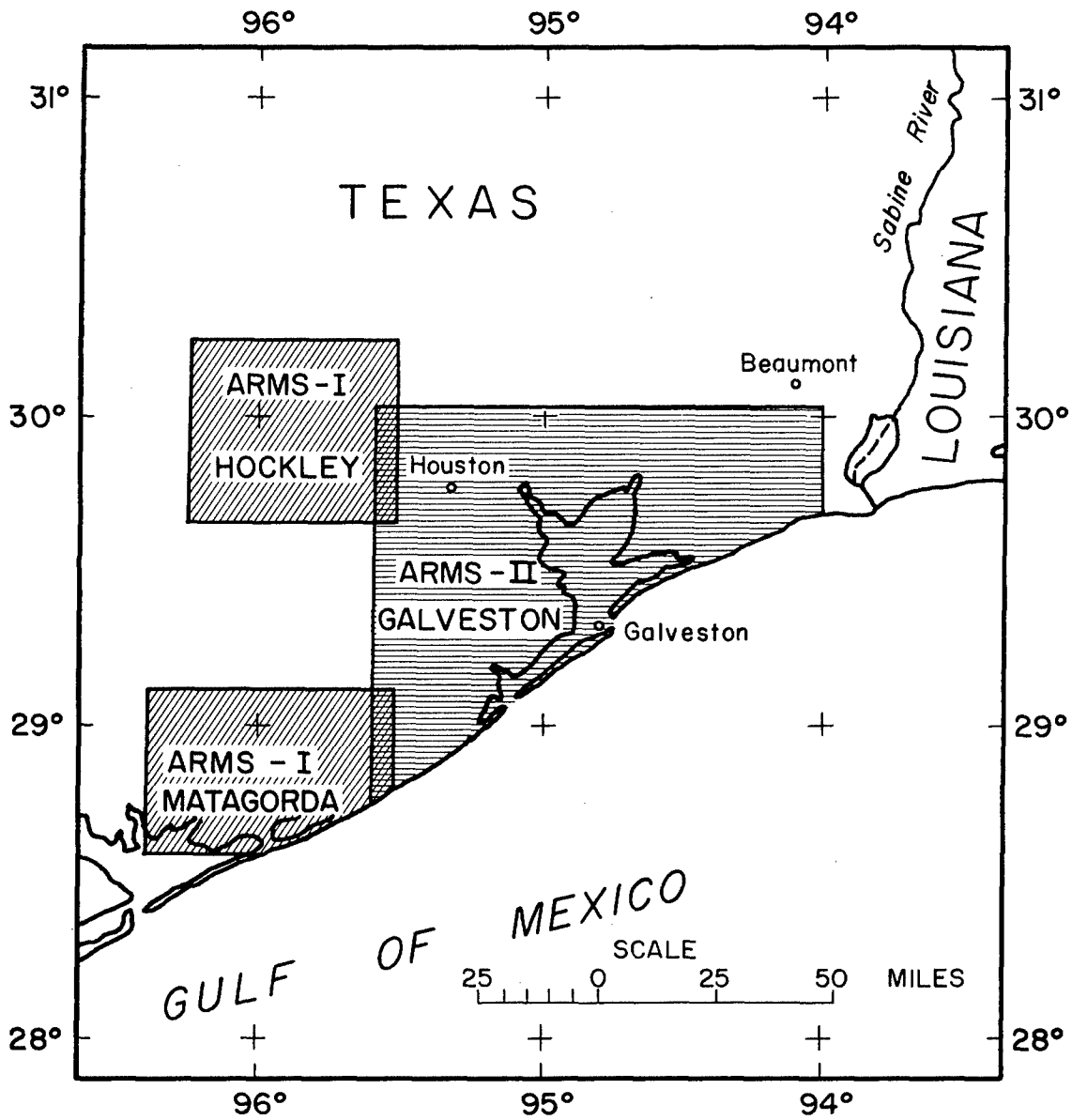

Fig. 1—Index map showing location of ARMS-II Galveston area and adjacent ARMS areas.

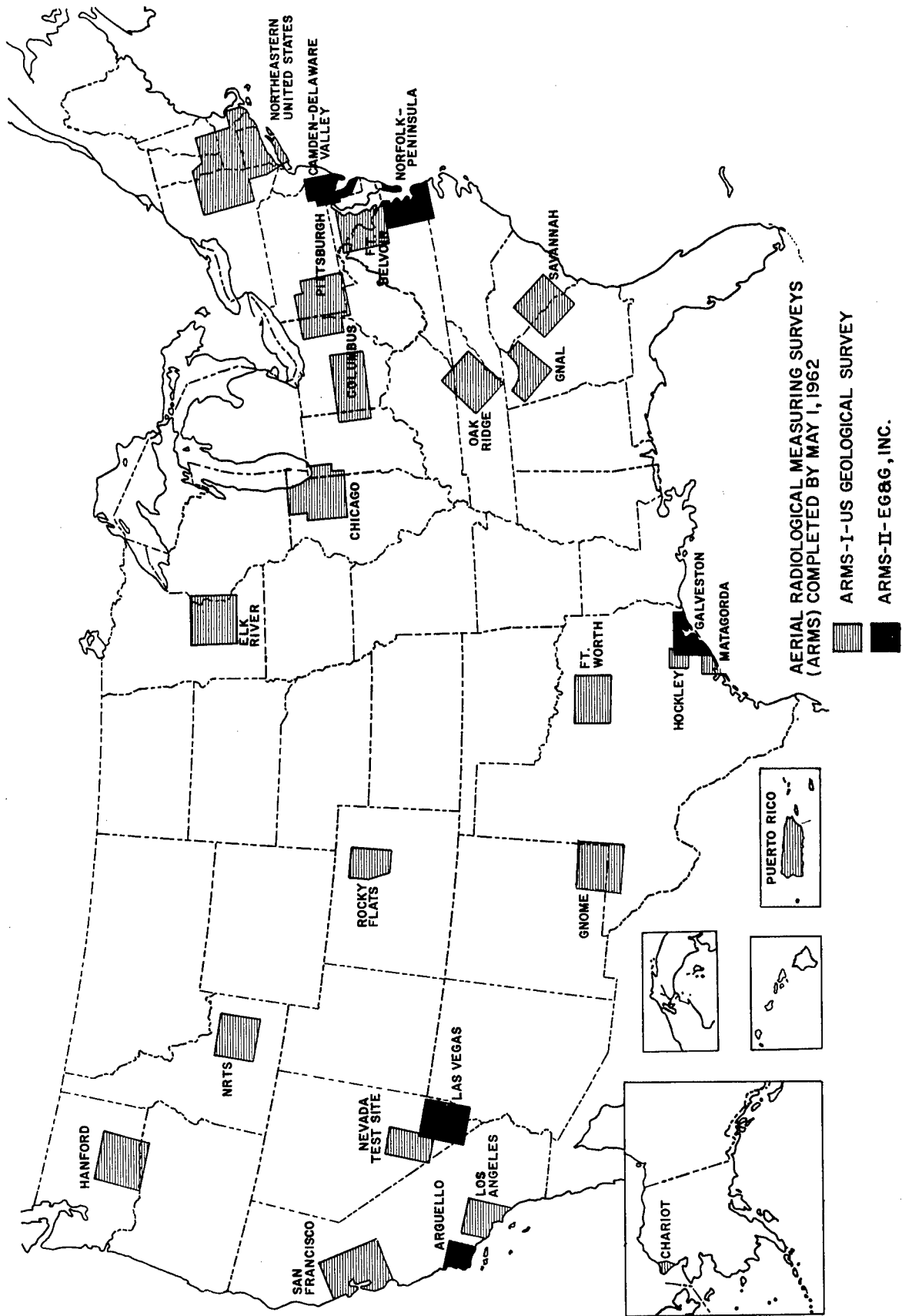

Fig. 2—Civil Effects Test Operations ARMS program.

altitude, and the value of the undesirable radiation, as measured at 3000 ft, was set into the radiation computer. The radiation data taken as the aircraft progressed down the survey line represented net terrestrial gamma radiation. During the survey flight each day, the radiation-detection apparatus was periodically calibrated to keep the drift in the detection system to a minimum.

Upon completion of each flight, the data tapes were removed from the aircraft and were immediately edited by the flight personnel. Pertinent information such as missing or obliterated ground check points, new points selected during flight, and equipment malfunction was immediately related to map locations and the radiation data. The corrected data were then entered onto the area working maps.

#### 1.4 Instrumentation

The EG&G ARMS-II instrumentation was installed in a Beechcraft, model 50 twin Bonanza, N702B. The apparatus consists of three subsystems (Fig. 3):

1. The radiation-detection and -measurement subsystem
2. The aircraft space-positioning subsystem
3. The information printout subsystem

The functions of these subsystems and their components are described in detail in Part II of USAEC Report CEX-59.4.<sup>1</sup>

The main detection unit utilizes a 9-in.-diameter 3-in.-thick thallium-activated sodium iodide crystal and a 12-in. photomultiplier tube. The radiation amplifier unit contains a voltage amplifier, a pulse shaper, and an energy base-line discriminator. The discriminator is set to reject pulses due to gamma rays with energies below 50 keV for a routine survey and 662 keV during calibration procedures using a Cs<sup>137</sup> source. The arithmetic computer performs the cosmic background correction, the compensation of the data for deviations from the nominal surveying altitude, the classification of count rate into channels, and gives print command signals to the information printout subsystem. The correction for cosmic and other undesirable background consists of subtracting from the gross count at 500 ft above the ground a count rate equal to the undesirable background; this gives the net count. This background is normally measured at 3000 ft above the ground. Compensation of the data for deviations from the nominal surveying altitude is accomplished through control of the sampling period by introducing a signal from the radar altimeter. The normal sampling period was 1 sec. The sampling period was less than 1 sec when the aircraft was below 500 ft and greater than 1 sec when the aircraft was more than 500 ft above the ground. The count rate was normalized to 500 ft above the ground in the range from 300 to 900 ft above the ground. The arithmetic computer classifies the count rate into digital channels of predetermined width. In the range of most natural materials, between 0 and 2000 counts/sec, the channel width is narrow; above 2000 counts/sec a progressively wider channel width is used.

The position of the aircraft is determined by a modified General Precision Laboratories Doppler navigation system. The J-4 compass system establishes a reference line against which the actual path of the aircraft is compared, the heading information being held by either a driven gyro or a magnetically slaved gyro. The RADAN 500 Doppler radar unit determines the ground speed and drift angle of the aircraft relative to the J-4 reference line. Signals from the J-4 compass and the RADAN 500 go to the TNC-50 (track navigation computer), where the along-track and the across-track distances relative to an initial ground point are computed. The along-track and the across-track distance signals then go to the analog-to-digital converter. Upon receipt of a print command from the radiation computer, these outputs go to the printer and are recorded.

The information printout subsystem consists of two data recorders: (1) a decimal printer and (2) a binary tape punch. The data recorded are: survey leg number, radiation channel, along-track distance, across-track distance and direction, and detector sensitivity. Since the radiation-detection and -measurement subsystem also contains a small crystal that is used in high-intensity fields, it was necessary to record which detector was in use during collection of the data.

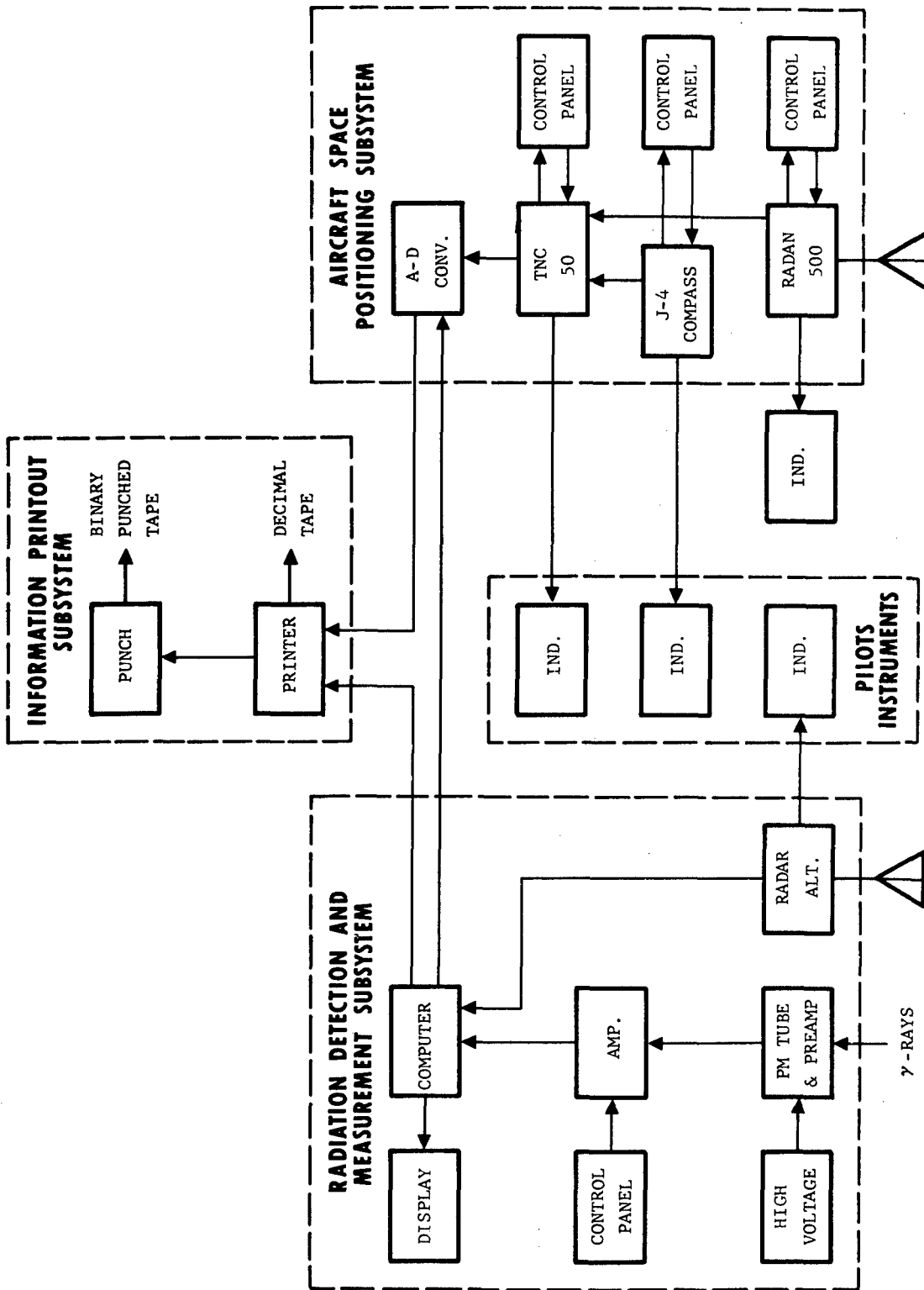

Fig. 3—Diagram of EG&G ARMS-II instrumentation.

## 2 THEORETICAL CONSIDERATIONS OF ARMS DATA

### 1 Sources of Gamma Rays

The gamma-ray activity that is measured by ARMS equipment at 500 ft above the ground has three principal origins: (1) cosmic radiation; (2) atmospheric sources, or the radionuclides in the air; and (3) terrestrial sources, which are the radionuclides in the surficial materials of the earth. It is not possible to measure directly the relative contribution of each source at a particular time while surveying, but certain assumptions and calibration procedures permit good estimates of the components of the gross gamma radiation to be made. A detailed discussion of sources of gamma rays is included in Uses of ARMS Data.<sup>2</sup> The following paragraphs present a brief summary of the most important of the gamma-ray sources that affect ARMS data.

The cosmic radiation component at 500 ft above the ground is due mainly to the air-scattered gamma rays that are induced by cosmic particles. The count rate at 3000 ft above the ground, where negligible radiation from the ground is present, is considered to be due to the cosmic component, the atmospheric sources, and the extraneous radiation. This contribution is measured each day while the ARMS flights are being conducted and is subtracted from the gross count at 500 ft above the ground to give the recorded net count rate.

The average 3000-ft background during the ARMS-II Galveston area survey was about 1220 counts/sec; of this amount 800 counts/sec was due to the calibration source in the aircraft.

The component of the gamma-ray activity at 500 ft above the ground which is due to radionuclides in the atmosphere cannot be separated directly from the terrestrial or cosmic components. Measurements of the artificial and natural radionuclides in ground-level air, however, have been made for several years by various investigators, and these measurements indicate that the contribution of atmospheric sources (principally radon daughter products) to the total count rate is normally insignificant. Abnormal situations occur during periods of severe inversion or immediately after testing of nuclear devices. When fission products are present in the air, they are assumed to be uniformly distributed; therefore their contribution to the count rate is removed with the cosmic background.

The terrestrial component of the gamma radiation found at 500 ft above the ground comes from the radionuclides in the surficial 12 in. of earth materials. Radionuclides in soil and, to a lesser extent, in rock are the major sources of gamma rays. Artificial radionuclides are generally concentrated in the surficial inch or two of material and, as is described later, probably have little effect on the distribution of aeroradioactivity units in the Galveston area. The present distribution of the surficial material and the concentrations of natural radionuclides in it are determined by the original content and form of the radioactive material in the parent rock and by changes brought about by geologic and pedologic processes.

The principal natural gamma-producing radionuclides found in rocks and soils are  $K^{40}$  and the members of the uranium and thorium series. The content of these radionuclides in various rocks is shown in Table 1.

There is a general trend for the content of these radionuclides in igneous rocks to increase with increasing silica content. Among the sedimentary rocks, shales are generally more radioactive than sandstones and carbonate rocks. The natural radioactivity of metamorphic rocks, unless radionuclides were added or removed during metamorphism, reflects the potassium, uranium, and thorium content of the original sedimentary or igneous rock. The concentrations of the natural radionuclides in soils are probably similar to the concentrations in sedimentary rocks because both are produced by the breakdown of preexisting rocks. The fine clayey and silty soils are generally more radioactive than coarser sandy soils because much of the soil radioactivity results from radioelements that are fixed or absorbed on clay. The interaction of various soil-forming processes, however, sometimes produces a concentration of radioactive accessory minerals and therefore an increase in total radioactivity in the surficial soil.

TABLE 1— $K^{40}$ , THORIUM, AND URANIUM IN IGNEOUS AND SEDIMENTARY ROCKS  
(in parts per million)

	Igneous rocks		Sedimentary rocks		
	Basaltic	Granitic	Shales	Sandstones	Carbonates
$K^{40}$					
Average	0.8	3.0	2.7	1.1	0.3
Range	0.2 to 2.0	2.0 to 6.0	1.6 to 4.2	0.7 to 3.8	0.0 to 2.0
Thorium					
Average	4.0	12.0	12.0	1.7	1.7
Range	0.5 to 10.0	1.0 to 25.0	8.0 to 18.0	0.7 to 2.0	0.1 to 7.0
Uranium					
Average	1.0	3.0	3.7	0.5	2.2
Range	0.2 to 4.0	1.0 to 7.0	1.5 to 5.5	0.2 to 0.6	0.1 to 9.0

## 2.2 Effect of Meteorological Conditions on Gamma-ray Flux from Terrestrial Sources

Changes in meteorological conditions have only a small effect on the gamma-ray flux at 500 ft which is produced by terrestrial sources. This subject is treated in detail by Merian et al.<sup>3</sup> The largest effect is caused by changes in the density of the air between the detector and the ground. The most important factor here, of course, is that of temperature variations. A temperature deviation of  $\pm 10^\circ\text{F}$  would create a maximum variation in count rate of  $\pm 3$  per cent. The effect of air-pressure variations on the uncertainty in the data is negligible. The change in air pressure of  $\pm 8$  mm would introduce an error of only 0.15 per cent in the count rate. Changes in relative humidity also have a small effect on the attenuation of gamma rays. If survey operations were proceeding at  $80^\circ\text{F}$  at 500 ft and the relative humidity were 50 per cent, the error that a change of  $\pm 50$  per cent in the relative humidity would introduce into the data would be about 0.9 per cent. The meteorological parameters of humidity, temperature, and pressure were recorded for each survey day, but, since their combined effect on the radiation levels was small, they were not used in the present application of the data. They are available, however, if a more detailed analysis of the data is required at some future time.

## 2.3 Conversion of Count Rate to Dose Rate

The EG&G ARMS-II instrumentation was designed to give data that are compatible with the data of the existing USGS ARMS-I equipment. Both units were flown over the Extended Source Calibration Area at the Nevada Test Site for cross-calibration purposes. The calibration range consisted of 400 equal-valued sources spaced on 100-ft centers to form a square that was 2000 ft on a side. The central source in the area was replaced by 100 smaller sources, spaced on 10-ft centers, the total intensity of which equaled that of the replaced source. The results of the flight measurements have been reported by F. J. Davis, Oak Ridge National Laboratory.<sup>4</sup>

$\text{Co}^{60}$  gammas: 22 counts/sec at 500 ft = 1  $\mu\text{r/hr}$  at 3 ft

$\text{Cs}^{137}$  gammas: 25 counts/sec at 500 ft = 1  $\mu\text{r/hr}$  at 3 ft

These figures should be applied to ARMS-II survey data with caution since any individual reading obtained with the ARMS-II equipment represents a radiation intensity that is integrated over a ground area approximately 900 ft in radius. In addition, no information is available concerning the energy of the radiation detected during survey operations. In view of these uncertainties and the small difference between the conversion factors for different gamma energies, a single conversion factor is recommended:

25 counts/sec at 500 ft = 1  $\mu\text{r/hr}$  at 3 ft

### 3 AERORADIOACTIVITY DATA

#### 3.1 Interpretation and Compilation

The present manual reduction of ARMS-II data from the decimal tape which was obtained during the survey to the aeroradioactivity units map, the form in which the data are presented, required two interpretation and two compilation steps.

The first step consisted of editing the decimal tape by selecting the data points that divide the flight lines into segments having similar radioactivity and the points that indicate known locations on the flight maps or major changes in flight path. The flight line was divided into segments because aeroradioactivity data for the ARMS-II Galveston area consisted of more than 30,000 data points. The distribution of radioactivity on the ground is such that a range in count rate is usually recorded on any segment of a flight line. If an area on the ground has a uniform gross gamma radioactivity, it will have associated with it a narrow range in count rate. A nonuniform gross gamma radioactivity, such as the bands of different width with different radioactivity produced by alternating sandstone, shale, and limestone beds, gives rise to a wide range in count rate. The segments were chosen to show as much information about the radioactivity as is consistent with the 1:250,000 compilation scale.

The second step, a compilation process, consisted of plotting the selected data points on tracing paper at map scale (1:250,000). The recorded Doppler distances were used to plot the flight line.

In the third step the flight lines were corrected for instrumental error, and the true positions of the data points were plotted on the compilation map. The correction consisted of the graphical proportioning of the error between the map locations of the segment end points. The "Doppler error," or the difference between the map position and the Doppler-indicated position of an end point, was less than 0.5 per cent of the distance flown. However, after the "Doppler error" was properly proportioned, the data points were accurate to within 0.1 mile, or 0.03 in. at map scale.

The final interpretative step in the reduction of the data was the delineation of aeroradioactivity units, or the selection of borders for areas having similar count rates on adjacent flight lines. Since the natural background radioactivity was commonly complex and since this detail was easily recorded by the ARMS instrumentation, the delineation of aeroradioactivity units put the data in a form that could be readily understood. The size of the units represents a compromise between the narrowest possible range in count rate and the largest possible area within one unit. Dissimilar count rates on adjacent lines, as well as fluctuations along a flight line, contributed to the width of the range of count rate for a particular aeroradioactivity unit. The upper limit of one unit may be the lower limit of an adjacent unit or the range of one unit may overlap the range of an adjacent unit. Since the data were prepared for presentation on a map at a scale of 1:250,000, or 4 miles equals 1 in., most of the units should be more than 2 miles wide (along the flight line) and should encompass more than four survey lines. Aeroradioactivity units as narrow as  $\frac{1}{2}$  mile are shown on the map if they differ substantially from adjacent units.

The aeroradioactivity data and units shown in Fig. 4 illustrate the philosophy and problems connected with the delineation of aeroradioactivity units. The numerical values that are listed represent gamma count rates in hundreds of counts per second. It can be seen that in many places the position of a unit boundary is unique and obvious, such as at A, B, and C. At other places, such as D, the placement of the boundary was arbitrary, and the dashed line could have been used. The selected boundary was chosen to indicate a unit with a slightly lower radioactivity to the right of the line; a single unit (3-7) instead of three units (4-7, 3-6, and 4-7) could have been used in this region. At E a unit boundary was drawn through a fairly uniform segment (8-10). This arbitrary division of a segment is avoided if possible, but it sometimes is necessary to simplify the shape of units while holding the range of units as narrow as possible. The 8-25 unit to the right of E is an example of a complex area that required a wide range in count rate to avoid a multitude of small units.

### 3.2 Presentation of Aeroradioactivity Data

Aeroradioactivity data for the ARMS-II Galveston area are presented in two forms: (1) a page-size generalized version at a scale of about 1:1,000,000 (16 miles equals 1 in.) (Fig. 5); and (2) a full-size version at a scale of 1:250,000 (4 miles equals 1 in.) (Plates 1, 2, and 3 in pocket).

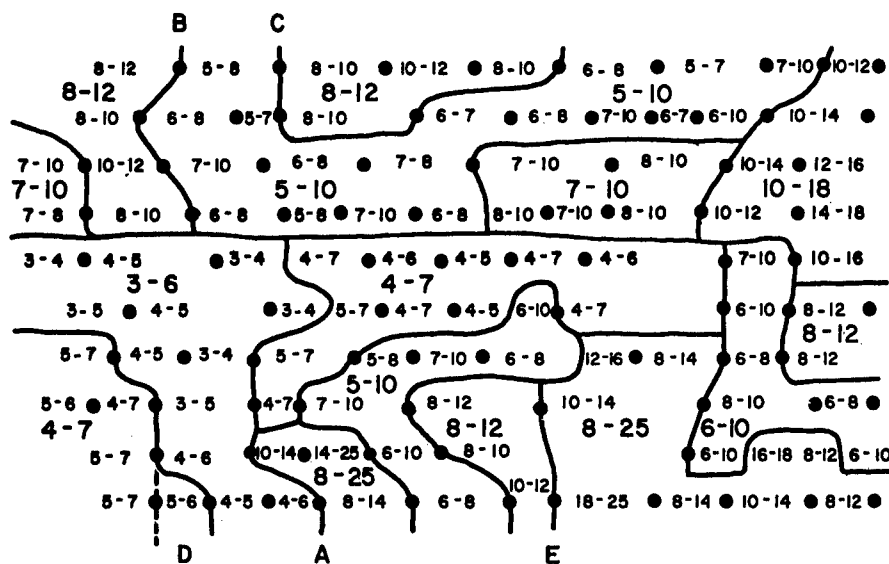

Fig. 4—Aeroradioactivity data and units (count rate in hundreds of counts per second).

#### 3.2.1 Generalized Aeroradioactivity Data

Two patterns are used in Fig. 5 to denote the generalized aeroradioactivity data for the area: areas where the maximum radioactivity was (1) mostly less than 400 counts/sec and (2) less than 800 counts/sec. Only the gross features are shown in this figure; aeroradioactivity unit boundaries have been smoothed, and small units have been deleted.

The radioactivity of the ARMS-II Galveston area is less than 800 counts/sec, and in much of the area the radioactivity is less than 400 counts/sec. If the qualifications mentioned in Sec. 2.3 are borne in mind, these measurements indicate that the ground dose rate due to terrestrial gamma radioactivity in the Galveston area is less than  $32 \mu\text{r/hr}$ , and in much of the area is less than  $16 \mu\text{r/hr}$ .

#### 3.2.2 Detailed Aeroradioactivity Data

The detailed aeroradioactivity units in the ARMS-II Galveston area are shown on Plates 1 to 3: the east part is shown on Plate 1; the west part is shown on Plate 2; and the south part is shown on Plate 3. These maps are printed so that the entire area can be studied by putting the three maps together without trimming. Topography and more-detailed cultural information for the area can be obtained from the Bay City, Beaumont, and Houston sheets, Topographic Maps of the United States, 1:250,000 scale series; these maps are available from the U. S. Geological Survey.

## 4 CORRELATION OF AERORADIOACTIVITY UNITS

The general distribution of the terrestrial radioactivity in the ARMS-II Galveston area probably can be attributed to the geology of the area. It is believed that a detailed study of the surficial geologic materials in the area would provide reasons for most of the aeroradioactivity units. To a large extent the terrestrial gamma radioactivity in the urban areas is probably a

consequence of the building and road materials used in these areas. Artificial radionuclides are probably present in only small quantities because the maximum background radioactivity in many places is less than 200 counts/sec. The distribution of artificial radionuclides in the area is assumed to be uniform.

#### 4.1 Correlation of Aeroradioactivity Units with Geology

The radioactivity of the ARMS-II Galveston area is probably a consequence of the geology of the area.<sup>5</sup> The generally low aeroradioactivity in the area is to be expected because of the numerous swamps and the widespread Quaternary clays, silts, and sand. The aeroradioactivity in the western part of the area, over the Beaumont clay (Pleistocene age) and the alluvial materials along the Brazos River, is slightly greater than in the rest of the area.

A complete correlation between aeroradioactivity units and geologic units was not made because of the following factors:

1. The small differences in the radioactivity of the surficial materials and the lack of detailed geologic information
2. The use of data from flight lines spaced 1 mile apart
3. The emphasis on environmental radioactivity rather than areal geology

#### 4.2 Correlation of Aeroradioactivity Units with Other Sources

All the aeroradioactivity units in the ARMS-II Galveston area are believed to result from the distribution of natural (not artificial) radionuclides in the surficial rocks and soils of the area.

### 5 SUMMARY AND CONCLUSIONS

The ARMS-II Galveston area survey was the fourth operational survey of a large area with the EG&G ARMS-II instrumentation. The operating procedures developed and proved in this and the previous surveys indicate that the system is extremely versatile, being capable of routine surveying on straight lines over areas of flat to moderate topography and of flying irregular individual traverses in mountainous terrain.

The radiation-detection and -measurement subsystem is sensitive to, and capable of recording, the environmental gamma background in a complex area where extremes of background radiation are encountered. The aircraft space-positioning subsystem can furnish accurate geographic locations in areas of flat and rugged topography and on straight or irregular flight lines.

Manual techniques for the reduction of the digital radiation and geographic position data have been developed to the point where data reduction can keep pace with surveying operations. Interpretation and reduction of the data are necessary to convert them to a form in which they can be presented on a map at a scale of 1:250,000 (or 4 miles equals 1 in.). The interpretation involves delineation of aeroradioactivity units or areas that have similar gamma radioactivity. Depending on the local complexity of the environmental gamma background radiation, these units can have a wide or narrow range in count rate.

Aerial measurements of ground radioactivity in the ARMS-II Galveston area are consistent with what would be expected, considering the geology of the area. The area has a generally low radioactivity which results from the numerous swamps and the widespread Quaternary clays, silts, and sand (which are usually weakly radioactive). The western part of the area, where the Beaumont clay and alluvial materials along the Brazos River comprise the surficial materials, is slightly more radioactive than the rest of the area.

### REFERENCES

1. J. E. Hand, R. B. Guillou, and H. M. Borella, Aerial Radiological Monitoring System. II. Performance, Calibration, and Operational Check-out of the EG&G ARMS-II Revised System, USAEC Report CEX-59.4, Oct. 1, 1962.

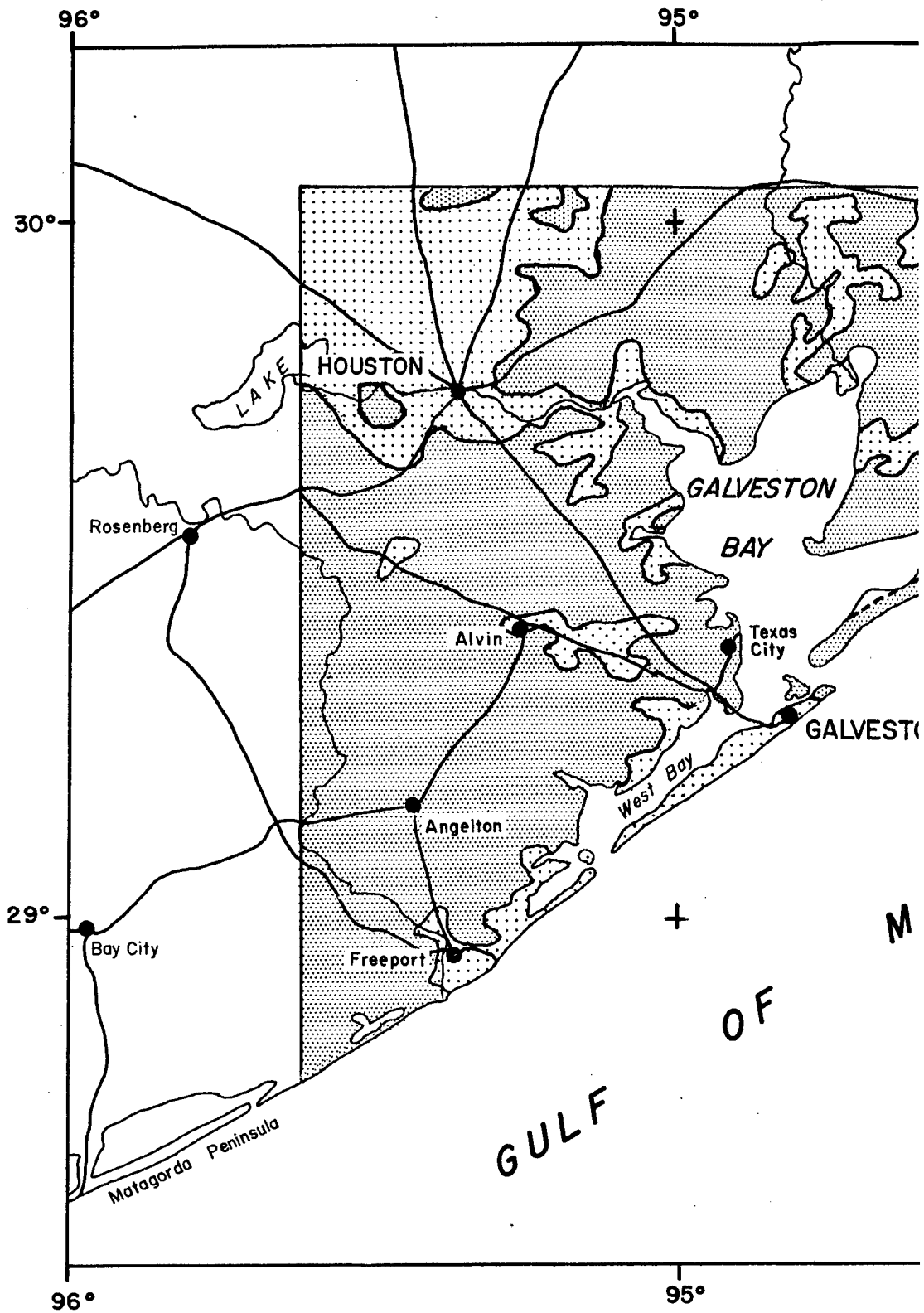
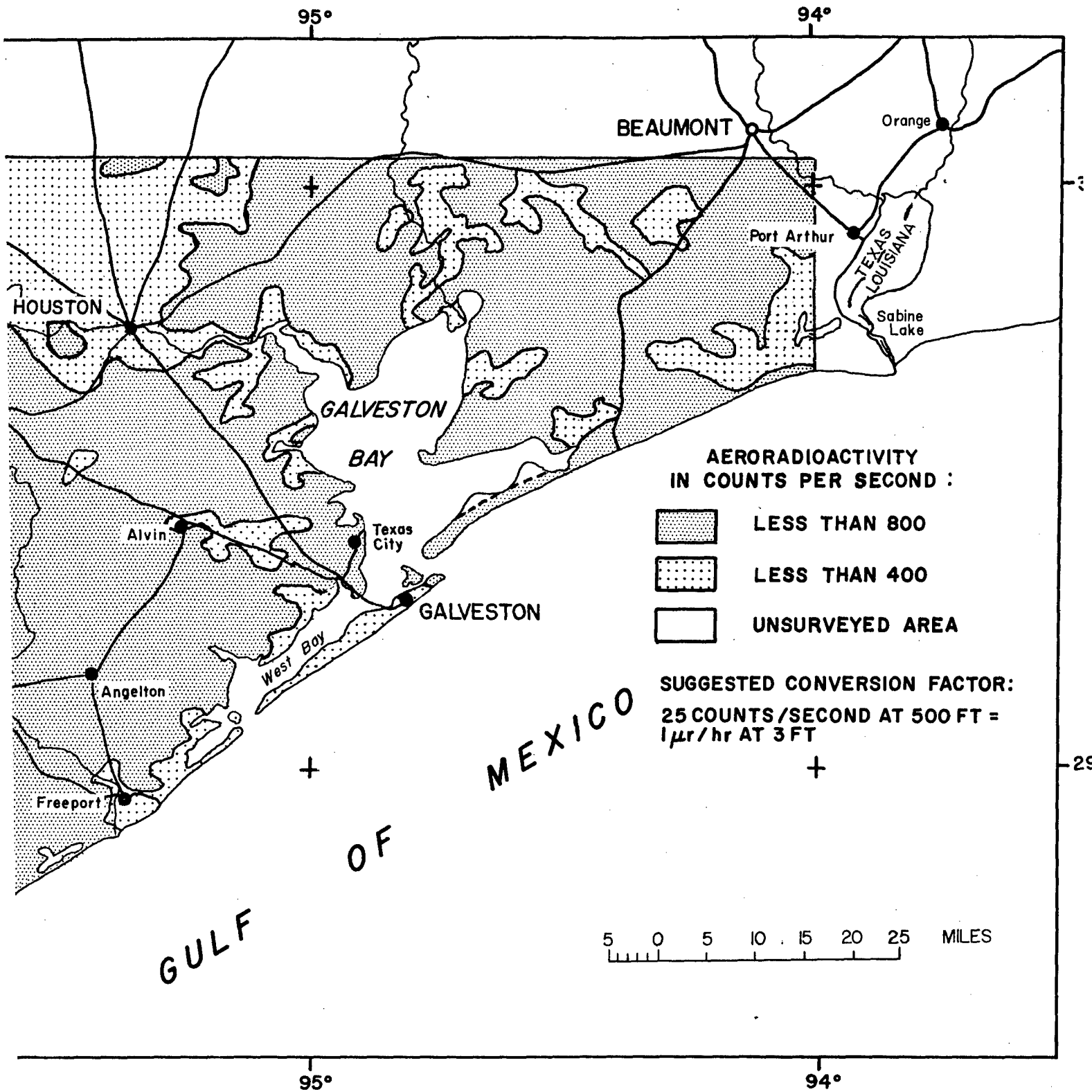

Fig. 5—Generalized aeroradioactivity map of the ARMS-II Galveston, Tex., area. Radioactivity by Edgerton, Germeshausen & Grier, Inc., Jan. 27 to Feb. 17, 1962, with aircraft N702B.)

①



ctivity map of the ARMS-II Galveston, Tex., area. Radioactivity levels in counts per second normalized to 500 ft above ground. (Surveyed rier, Inc., Jan. 27 to Feb. 17, 1962, with aircraft N702B.)

2. Edgerton, Germeshausen & Grier, Inc., Uses of ARMS Data (in preparation).
3. R. F. Merian, J. G. Lackey, and J. E. Hand, Aerial Radiological Monitoring System. I. Theoretical Analysis, Design; and Operation of a Revised System, USAEC Report CEX-59.4, February 1961.
4. F. J. Davis and P. W. Reinhardt, Extended- and Point-source Radiometric Program, USAEC Report CEX-60.3, August 1962.
5. G. W. Stose (Comp.), Geologic Map of Texas, U. S. Geological Survey, 1937.

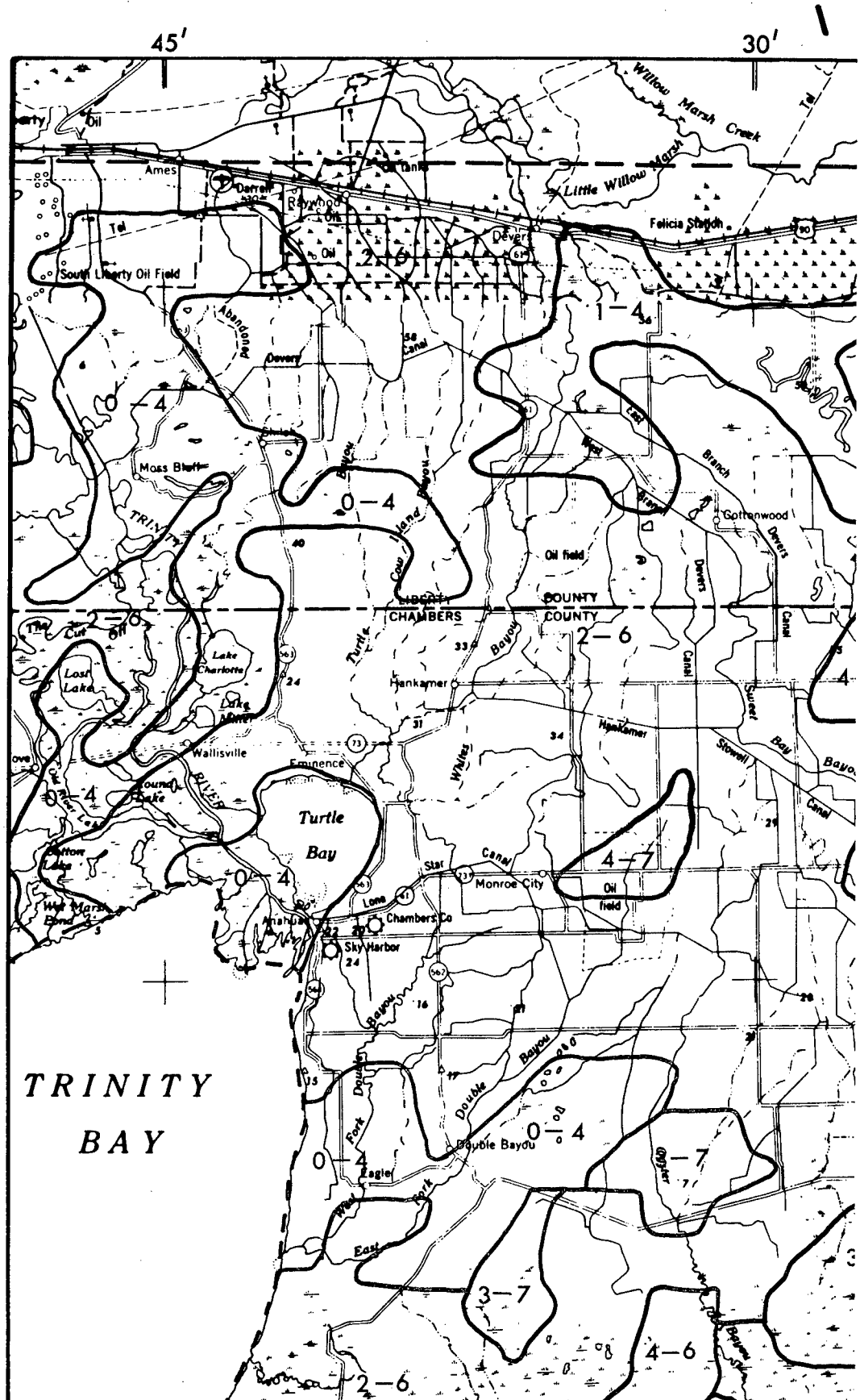

TRINITY  
BAY

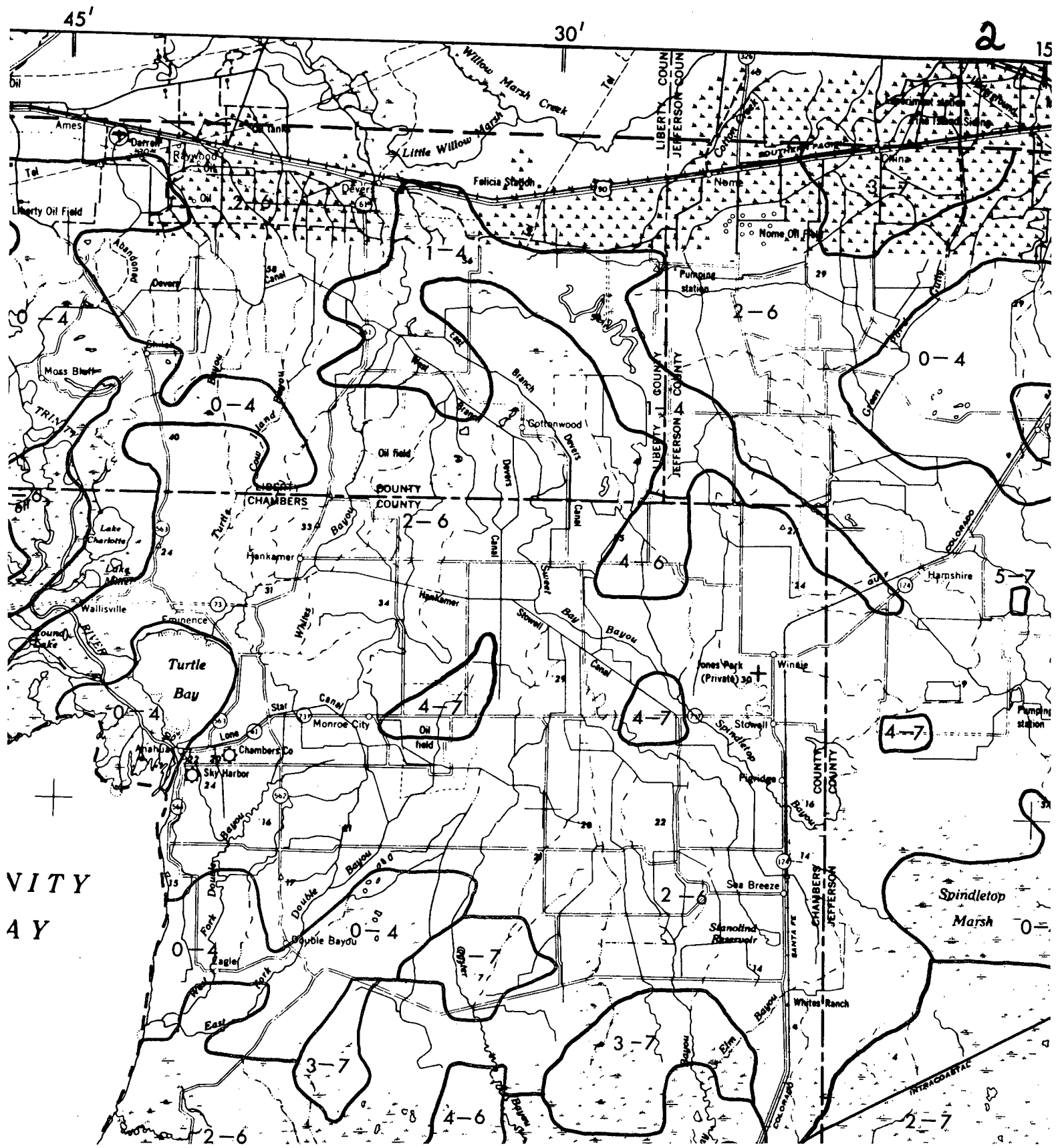

45'

30'

2

15

VITY  
AY

4-7

2-6

3-7

4-6

3-7

2-7

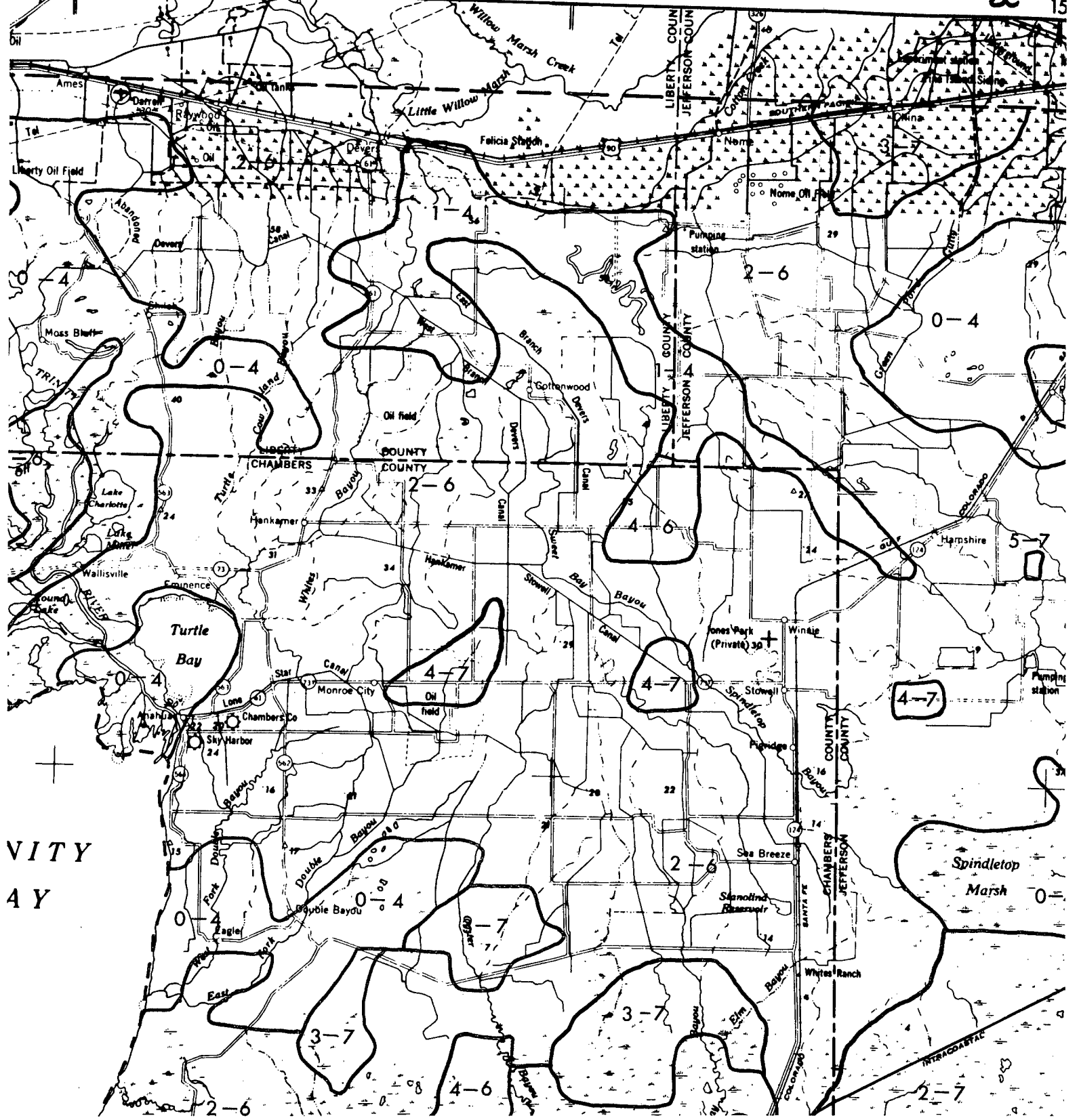



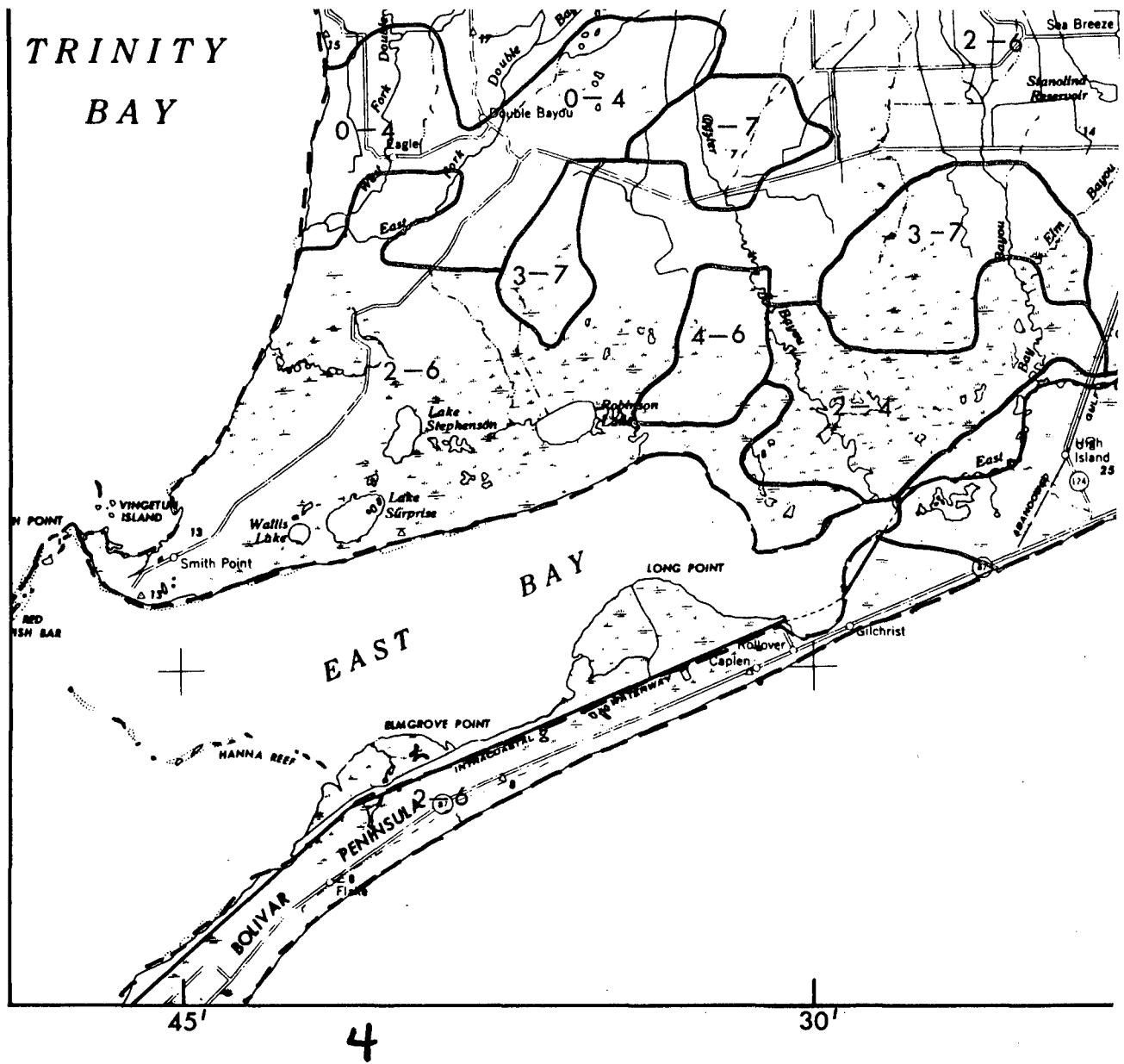

# AERORADIOACT

## ARMS II GALVESTON

RADIOACTIVITY LEVELS IN HUNDREDS OF COUNTS PER SURVEYED BY EG & G, INC., WITH AIRCRAFT N702B.

BASE FROM TOPOGRAPHIC MAPS OF THE U.S.

SCALE 1/250,000

SHEETS:

BAY CITY  
BEAUMONT  
HOUSTON

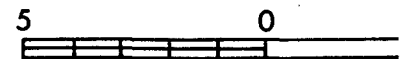

SUGGESTED CONVER  
25 counts/sec at 500 f

### PLATE 1 EAST PART

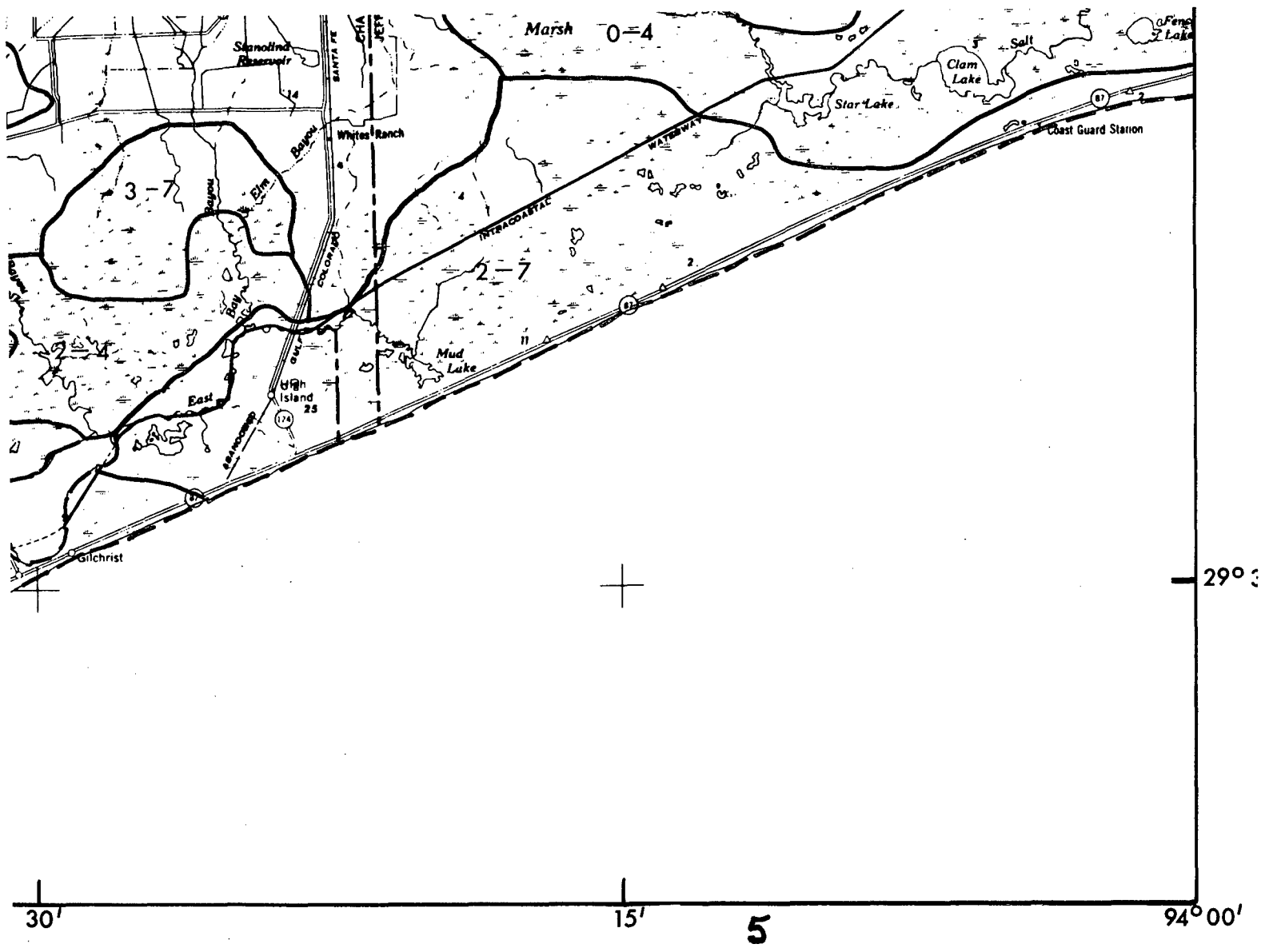

# AERORADIOACTIVITY MAP I GALVESTON AREA, TEXAS

OF COUNTS PER SECOND NORMALIZED TO 500 FT ABOVE GROUND  
AFT N 702 B. JANUARY 26 - FEBRUARY 17, 1962

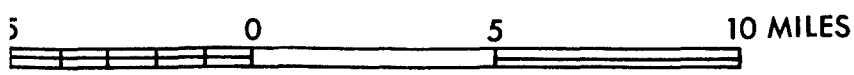

SUGGESTED CONVERSION FACTOR  
25 counts/sec at 500 ft = 1  $\mu$ r/hr at 3 ft

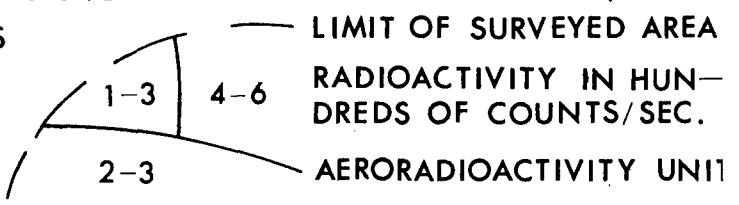

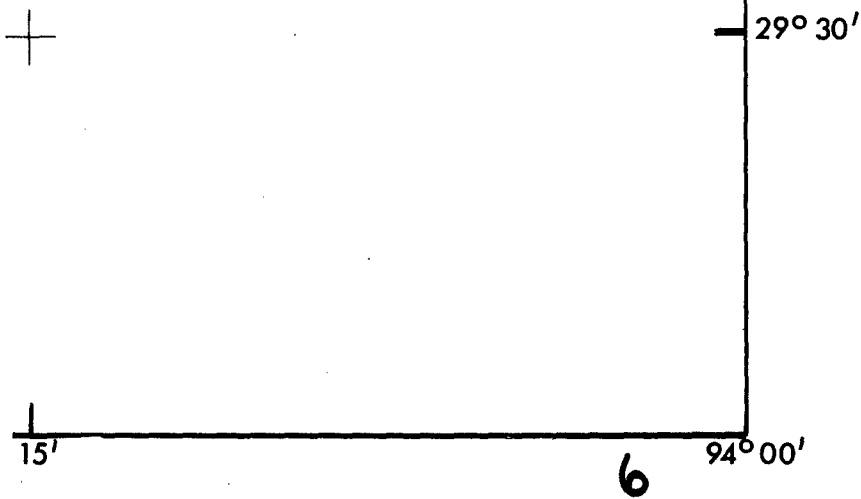
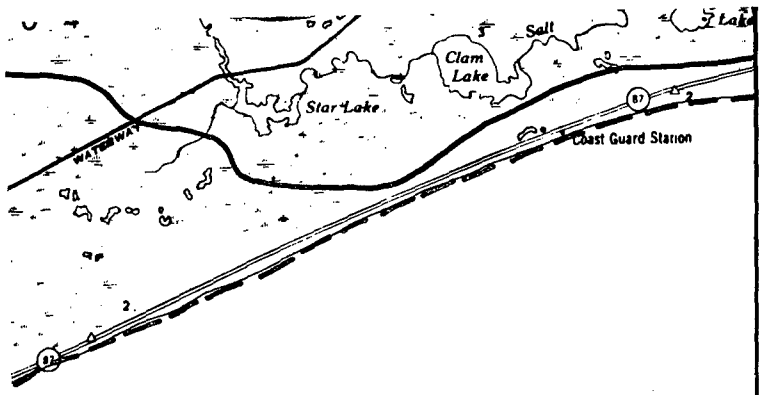

S

ALIZED TO 500 FT ABOVE GROUND  
 JANUARY 26 - FEBRUARY 17, 1962

MILES

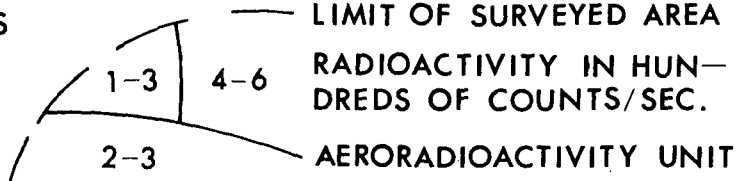







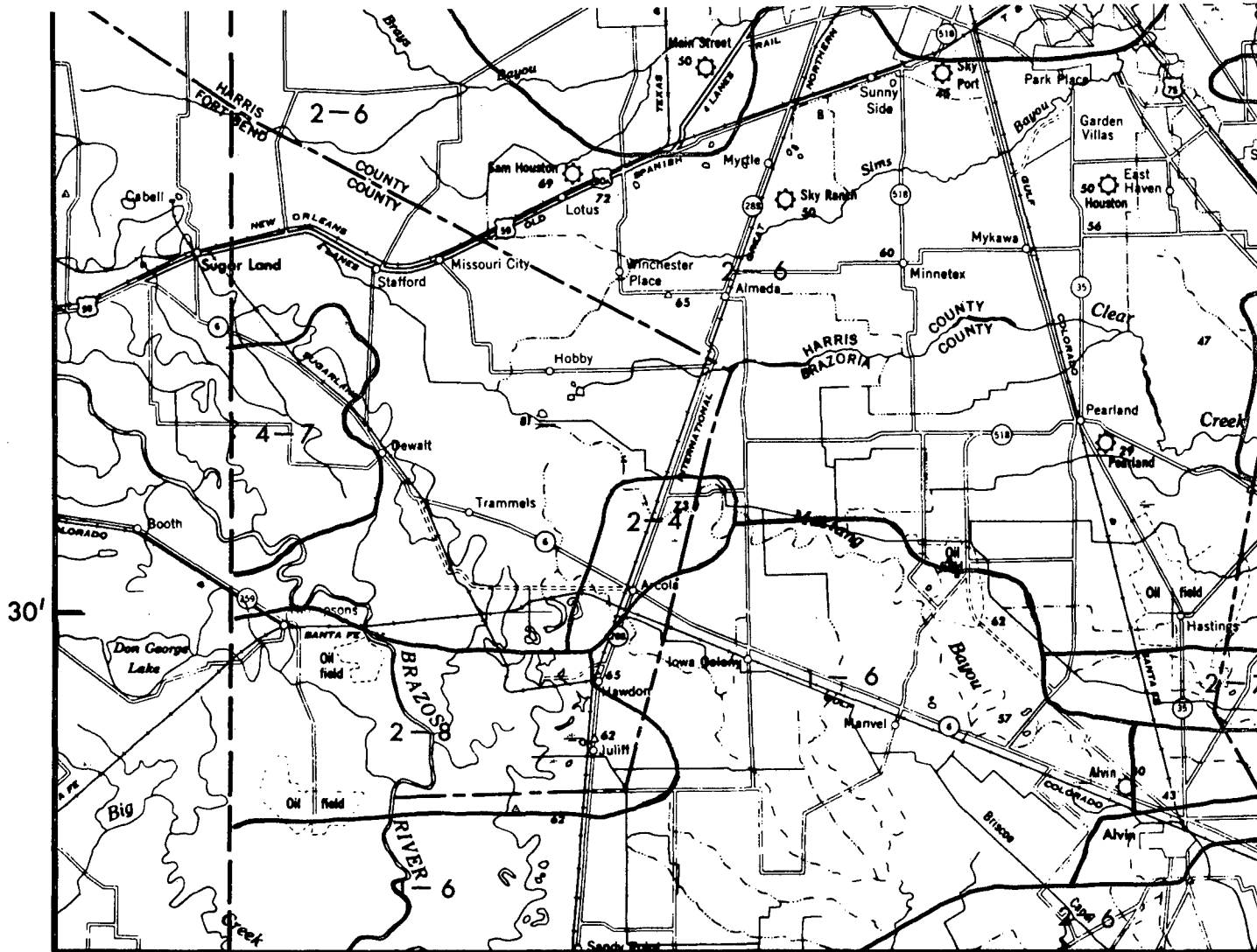

4

**AERORADIATION**

**ARMS II GALVE**

**RADIOACTIVITY LEVELS IN HUNDREDS OF COUNTS PER SECOND  
 SURVEYED BY EG & G, INC., WITH AIRCRAFT N7021**

BASE FROM TOPOGRAPHIC MAPS OF THE U.S.  
 SCALE 1/250,000 SHEETS: BAY CITY  
 BEAUMONT  
 HOUSTON

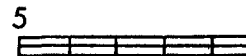

**SUGGESTED  
 25 counts/se**

**PLATE 2 WEST PART**

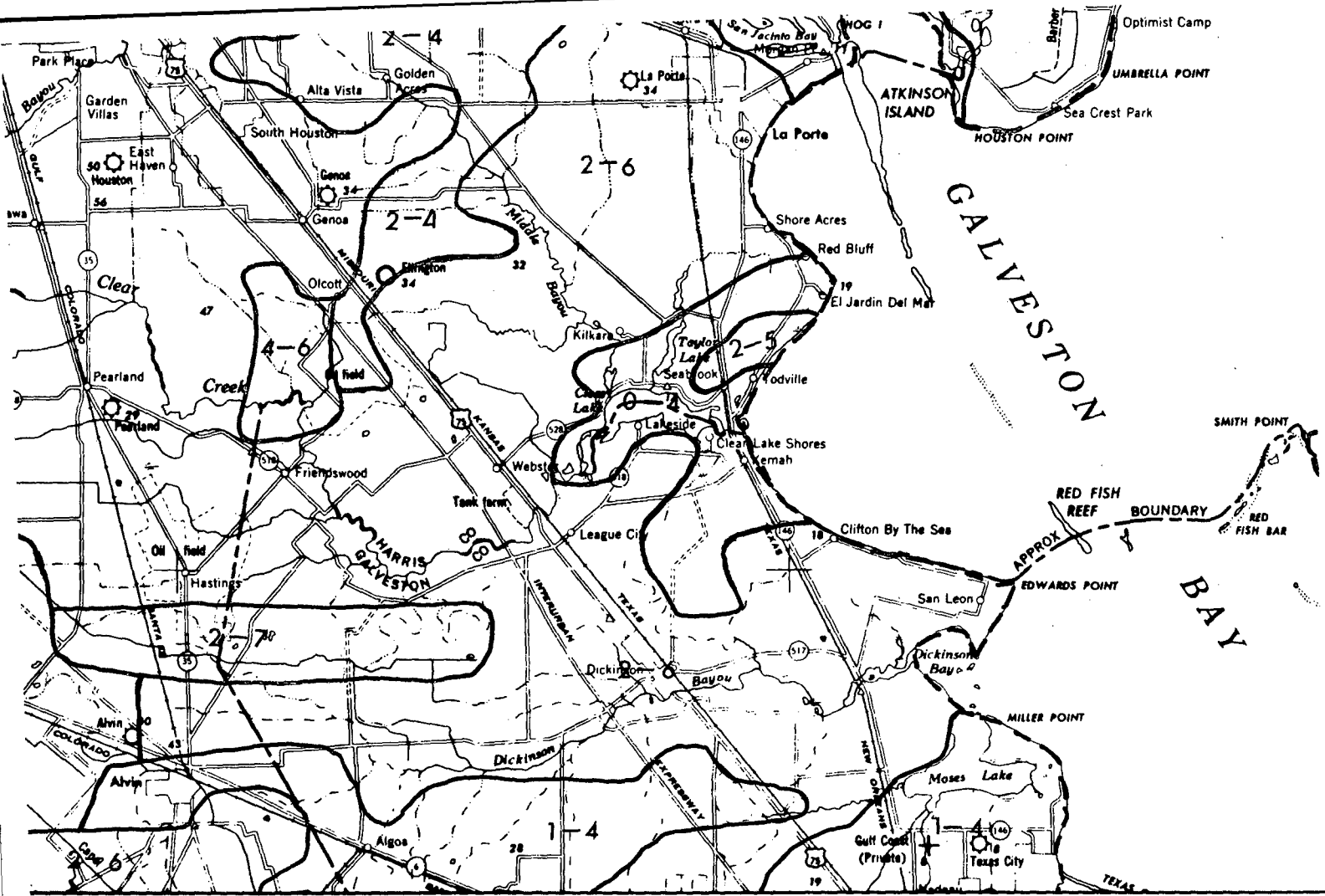

5

# AERORADIOACTIVITY MAP

## II GALVESTON AREA, TEXAS

OF COUNTS PER SECOND NORMALIZED TO 500 FT ABOVE GROUND  
 RAFT N702B. JANUARY 26 - FEBRUARY 17, 196

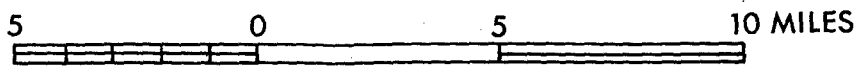

SUGGESTED CONVERSION FACTOR  
 25 counts/sec at 500 ft = 1  $\mu$ r/hr at 3 ft

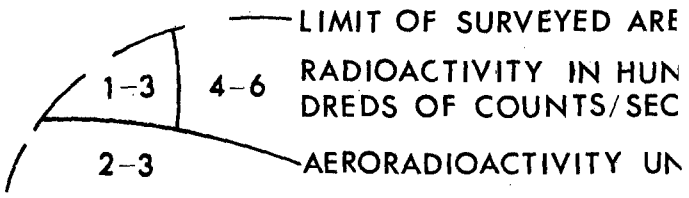

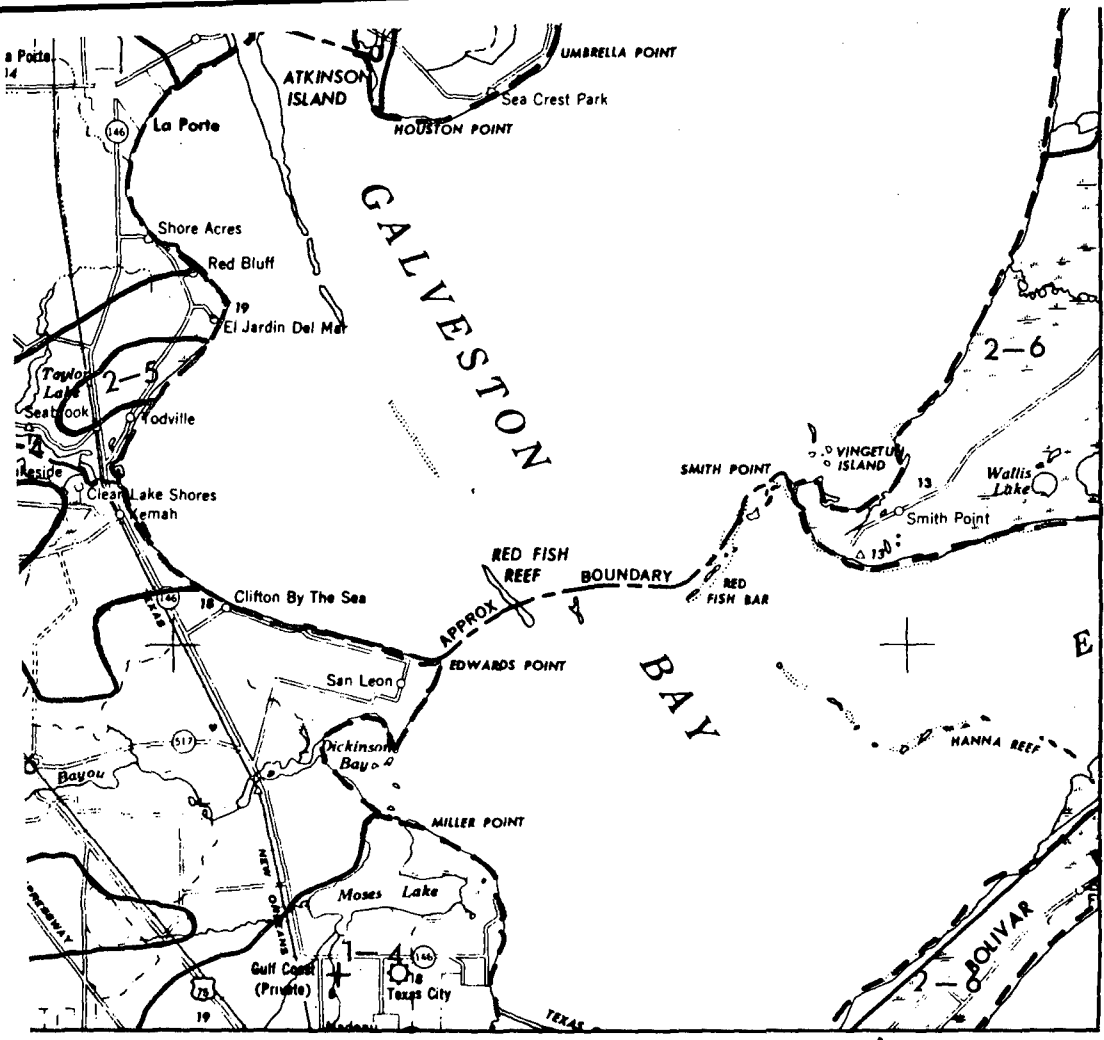

6

AS

ALIZED TO 500 FT ABOVE GROUND  
 JANUARY 26 - FEBRUARY 17, 1962

0 MILES

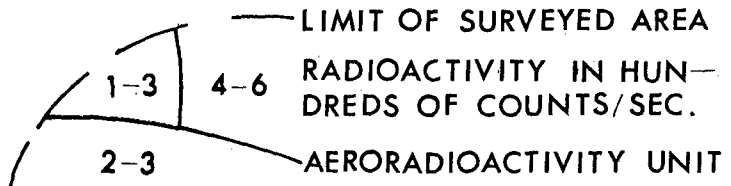

30'

15'

29°00'

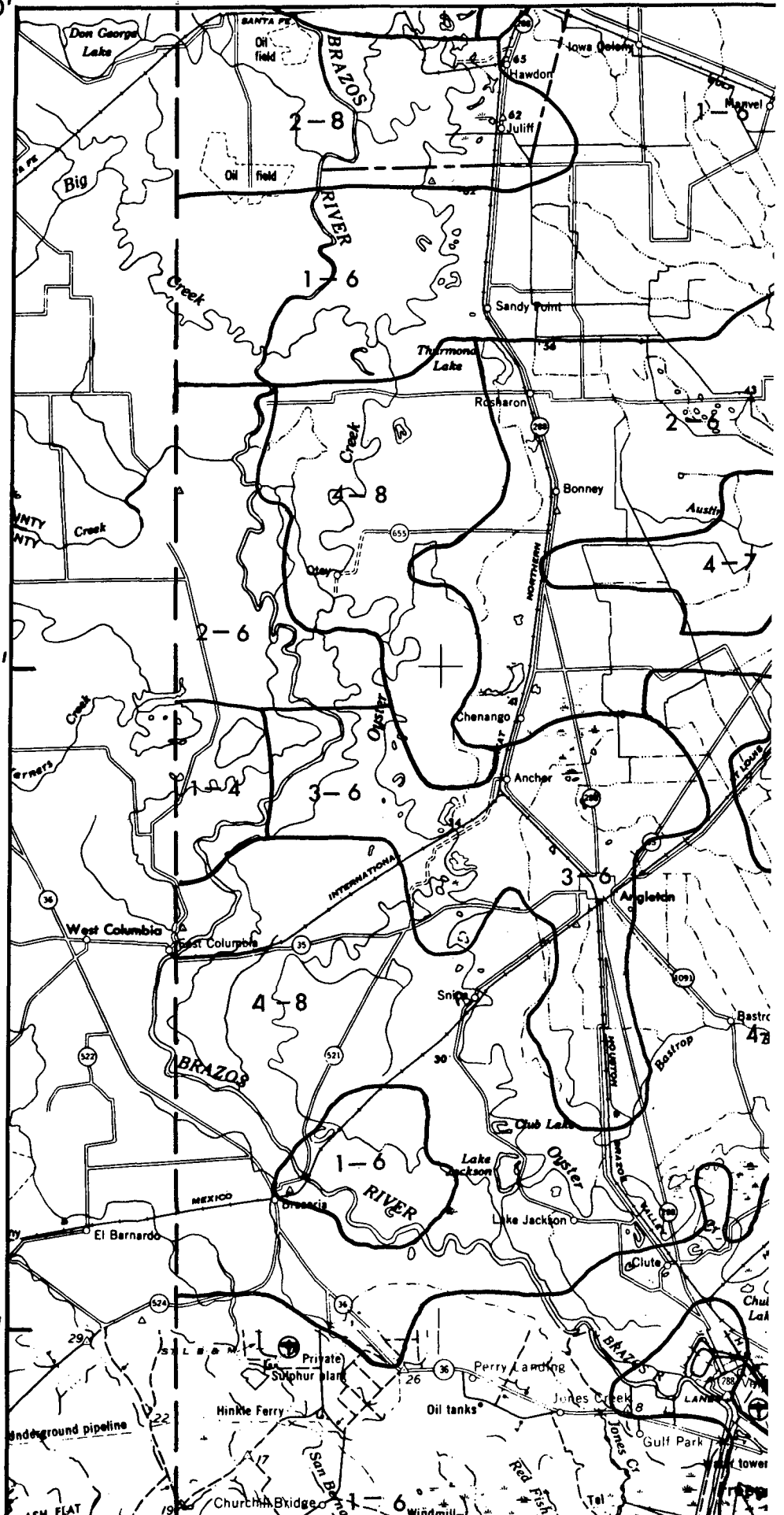

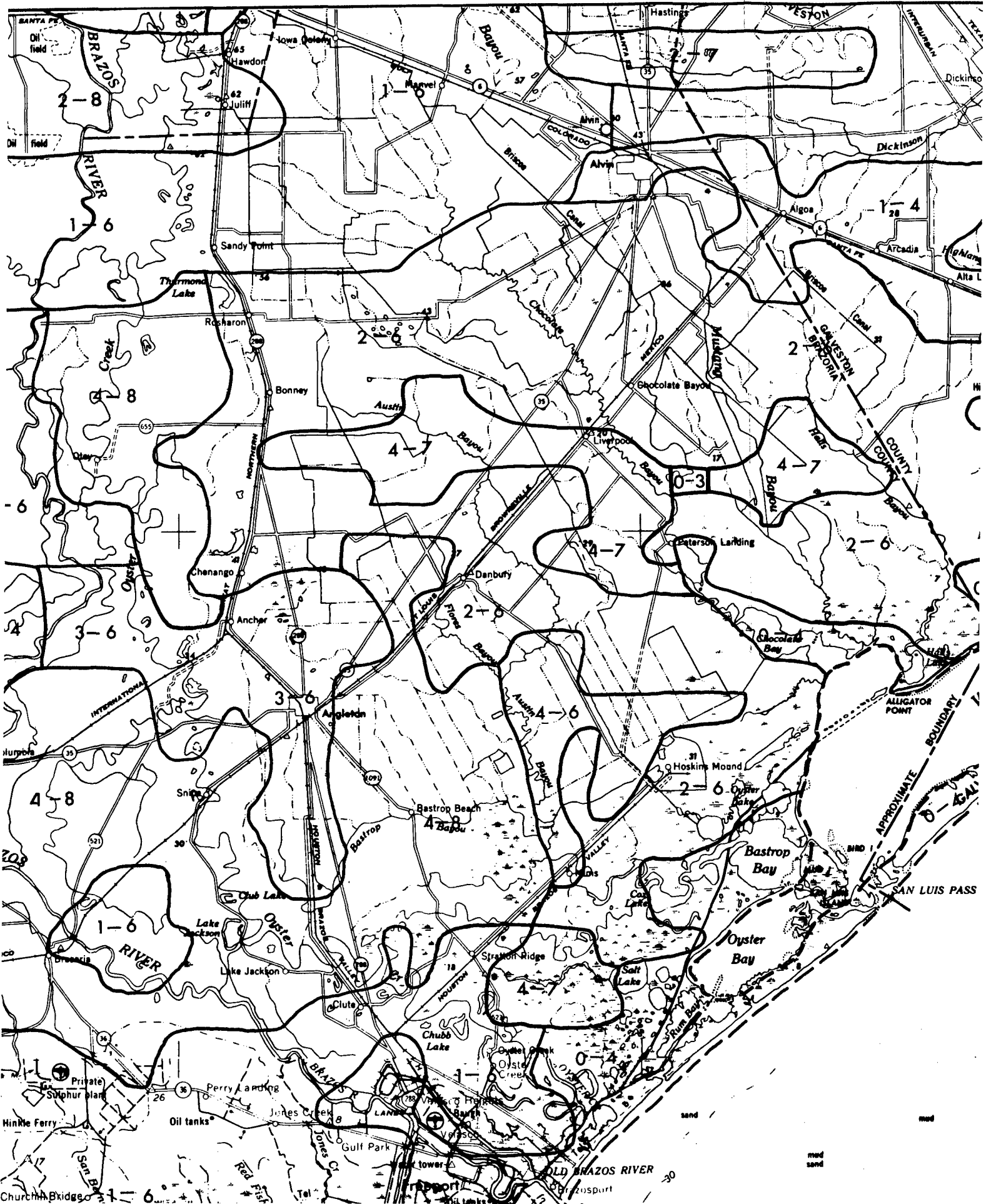

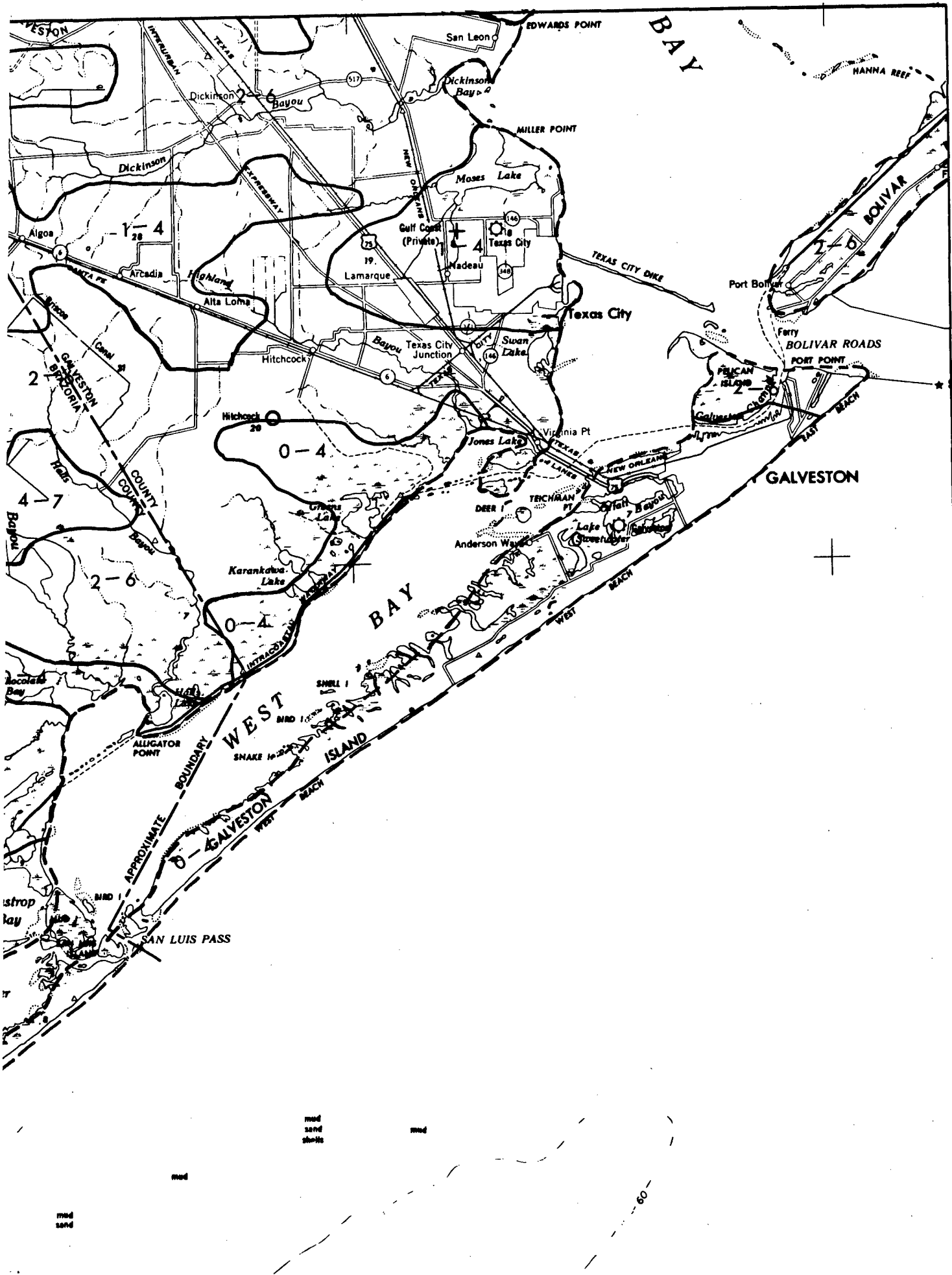

29°00'

45'

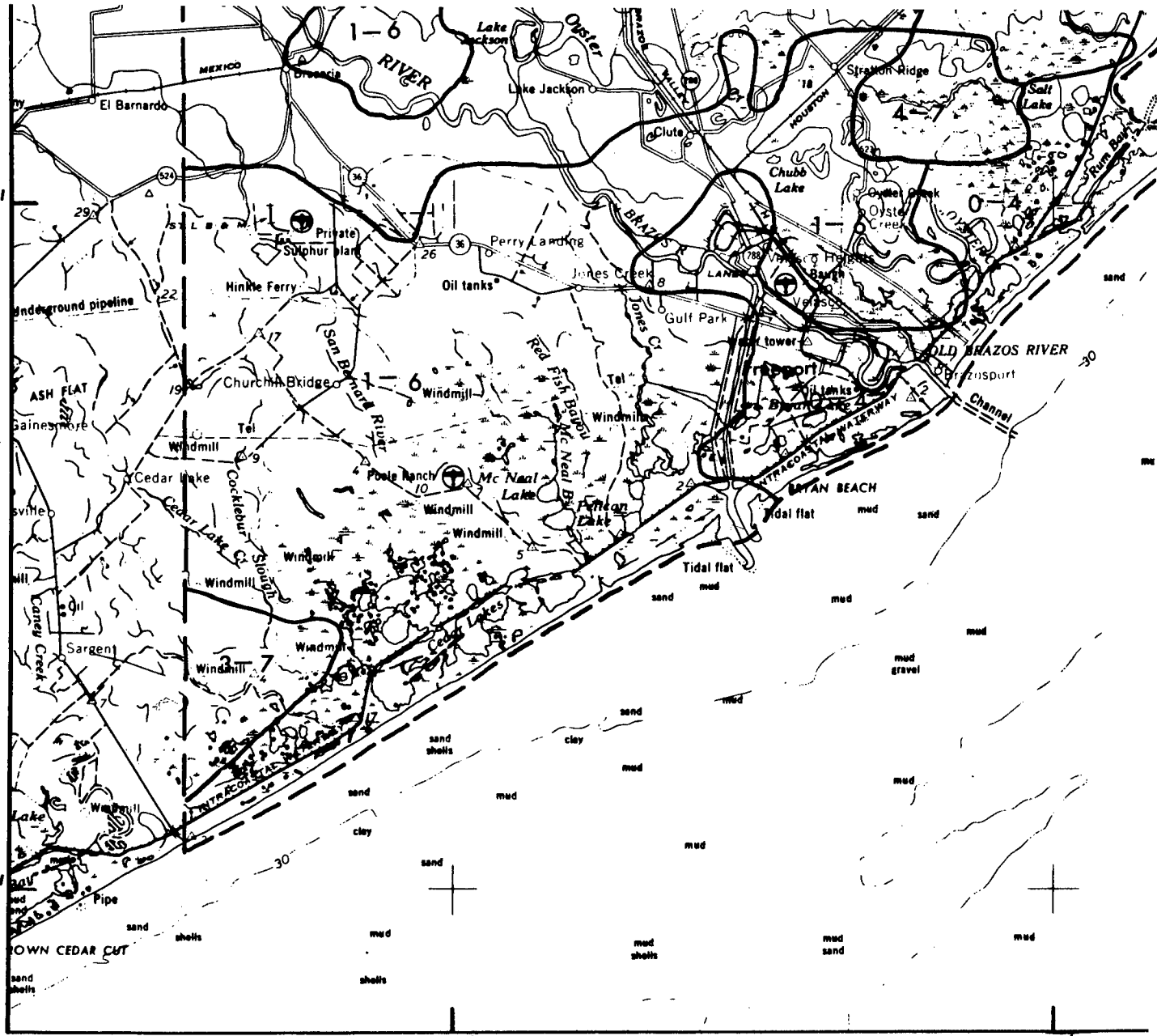

4

# AERORADIATION

## ARMS II GALVE

RADIOACTIVITY LEVELS IN HUNDREDS OF COUNT SURVEYED BY EG & G, INC., WITH AIRCRAFT N702

BASE FROM TOPOGRAPHIC MAPS OF THE U.S.  
SCALE 1/250,000 SHEETS: BAY CITY  
BEAUMONT  
HOUSTON

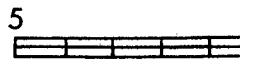

SUGGESTED  
25 counts/s

### PLATE 3 SOUTH PART

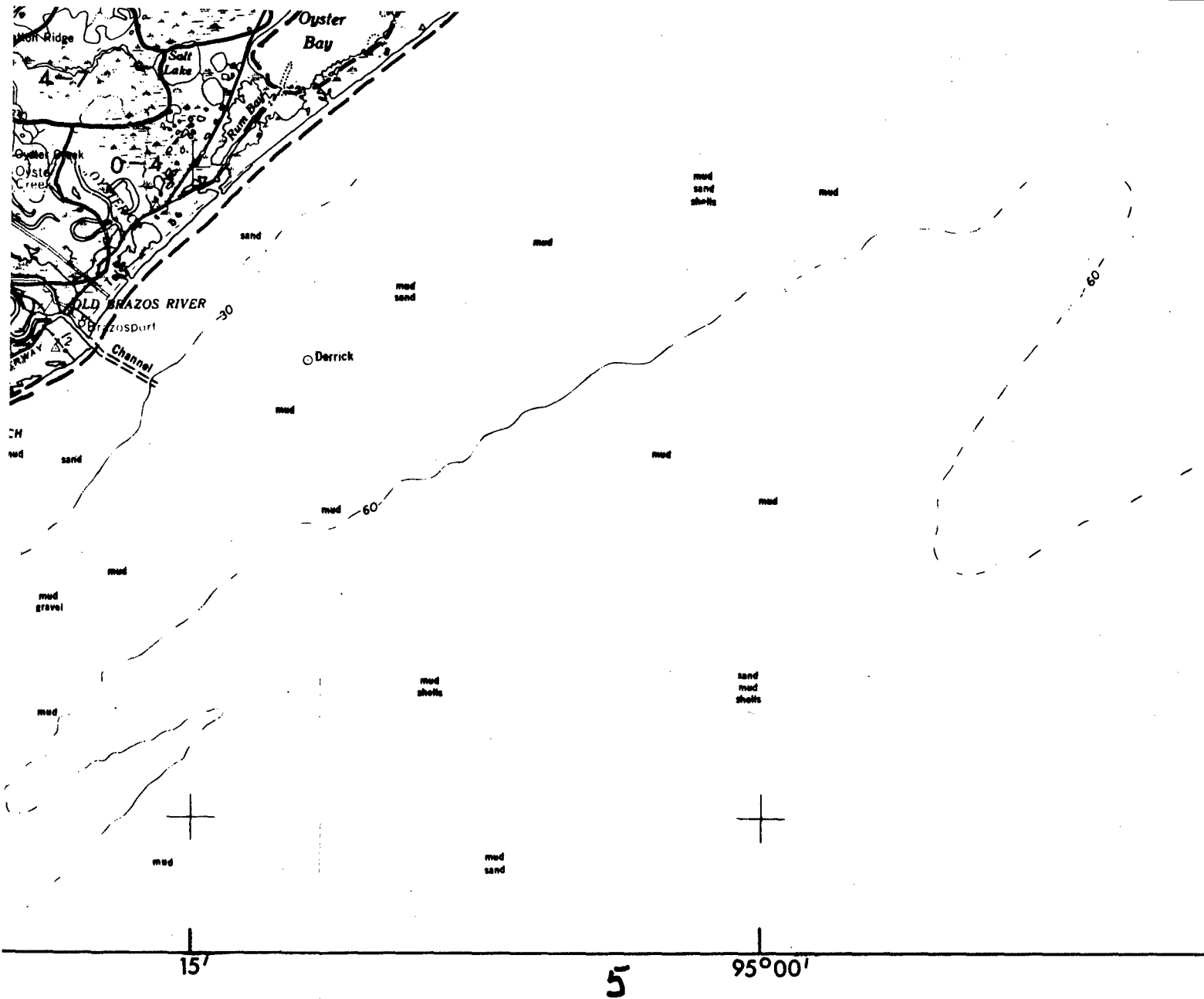

# AERORADIOACTIVITY MAP

## MS II GALVESTON AREA, TEXAS

REDS OF COUNTS PER SECOND NORMALIZED TO 500 FT ABOVE GROUND  
 AIRCRAFT N702B, JANUARY 26 - FEBRUARY 1, 1954

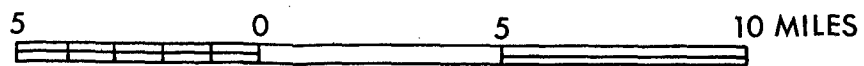

SUGGESTED CONVERSION FACTOR  
 25 counts/sec at 500 ft = 1  $\mu$ r/hr at 3 ft

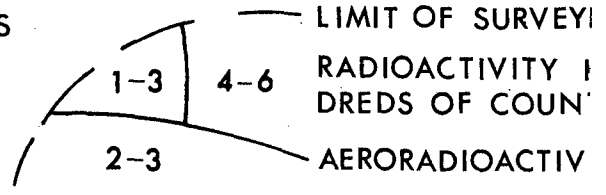

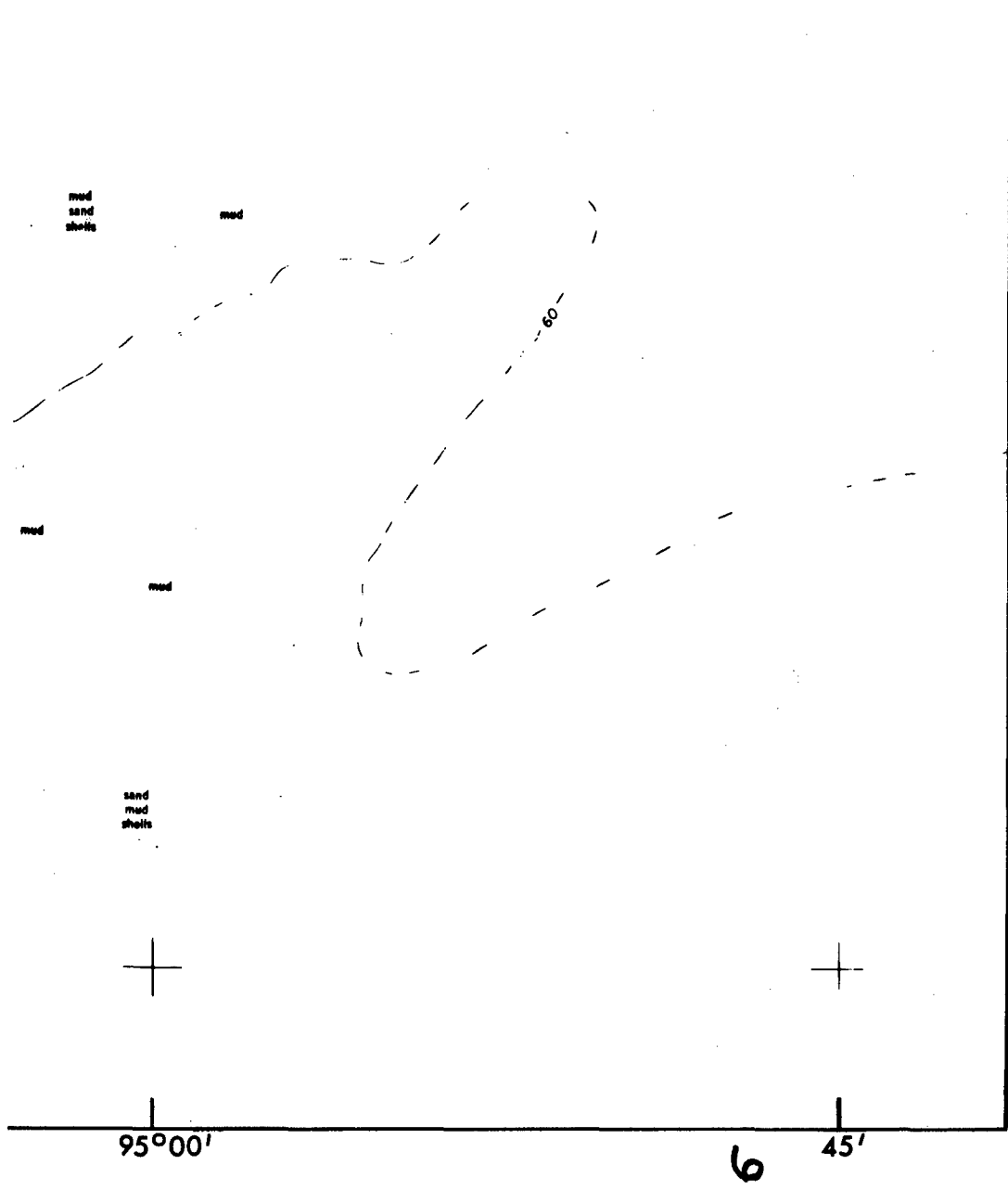

P

CAS

MAINTAINED TO 500 FT ABOVE GROUND  
 JANUARY 26 - FEBRUARY 17, 1962

10 MILES

