

AFRL-IF-RS-TR-2005-305
Final Technical Report
August 2005



GLOBAL INFORMATION ENTERPRISE (GIE) MODELING AND SIMULATION (GIESIM)

Syracuse Research Corporation

APPROVED FOR PUBLIC RELEASE; DISTRIBUTION UNLIMITED.

**AIR FORCE RESEARCH LABORATORY
INFORMATION DIRECTORATE
ROME RESEARCH SITE
ROME, NEW YORK**

STINFO FINAL REPORT

This report has been reviewed by the Air Force Research Laboratory, Information Directorate, Public Affairs Office (IFOIPA) and is releasable to the National Technical Information Service (NTIS). At NTIS it will be releasable to the general public, including foreign nations.

AFRL-IF-RS-TR-2005-305 has been reviewed and is approved for publication

APPROVED: /s/

JON B. VALENTE
Project Engineer

FOR THE DIRECTOR: /s/

WARREN H. DEBANY, JR., Technical Advisor
Information Grid Division
Information Directorate

REPORT DOCUMENTATION PAGE

Form Approved
OMB No. 074-0188

Public reporting burden for this collection of information is estimated to average 1 hour per response, including the time for reviewing instructions, searching existing data sources, gathering and maintaining the data needed, and completing and reviewing this collection of information. Send comments regarding this burden estimate or any other aspect of this collection of information, including suggestions for reducing this burden to Washington Headquarters Services, Directorate for Information Operations and Reports, 1215 Jefferson Davis Highway, Suite 1204, Arlington, VA 22202-4302, and to the Office of Management and Budget, Paperwork Reduction Project (0704-0188), Washington, DC 20503

1. AGENCY USE ONLY (Leave blank)		2. REPORT DATE AUGUST 2005	3. REPORT TYPE AND DATES COVERED Final Apr 03 – May 05	
4. TITLE AND SUBTITLE GLOBAL INFORMATION ENTERPRISE (GIE) MODELING AND SIMULATION (GIESIM)			5. FUNDING NUMBERS C - F30602-03-C-0074 PE - 62702F PR - GIES TA - RC WU - 03	
6. AUTHOR(S) Paul Bell				
7. PERFORMING ORGANIZATION NAME(S) AND ADDRESS(ES) Syracuse Research Corporation 6225 Running Ridge Road North Syracuse New York 13212			8. PERFORMING ORGANIZATION REPORT NUMBER N/A	
9. SPONSORING / MONITORING AGENCY NAME(S) AND ADDRESS(ES) Air Force Research Laboratory/IFGA 525 Brooks Road Rome New York 13441-4505			10. SPONSORING / MONITORING AGENCY REPORT NUMBER AFRL-IF-RS-TR-2005-305	
11. SUPPLEMENTARY NOTES AFRL Project Engineer: Jon B. Valente/IFGA/(315) 330-1559/ Jon.Valente@rl.af.mil				
12a. DISTRIBUTION / AVAILABILITY STATEMENT APPROVED FOR PUBLIC RELEASE; DISTRIBUTION UNLIMITED.				12b. DISTRIBUTION CODE
13. ABSTRACT (Maximum 200 Words) The objective of this effort was the integration of communication and network modeling and simulation (M&S) toolkits into the Global Information Enterprise (GIE) Modeling and Simulation (GIESim) framework to create effective user analysis of candidate communications architectures and technologies. Operational tactical communication scenarios to demonstrate, evaluate, and validate the GIESim were developed in a team environment that brought together M&S and communications subject area expertise from highly technical companies and AF groups with the know-how necessary to leverage existing experience and emerging communications models. GIESim included AFRL employees at Rome and Wright Research Sites and large and small scientific companies. The final phase of the effort was the merger of GIESim Joint Tactical Information Distribution System (JTIDS) simulation with Joint Semi-Automated Forces (JSAF), adding tactical communications modeling (TCM) to JSAF. TCM plays an increasingly critical role in military operations.				
14. SUBJECT TERMS Modeling and Simulation, Communications Modeling, Network in Network Modeling			15. NUMBER OF PAGES 36	
			16. PRICE CODE	
17. SECURITY CLASSIFICATION OF REPORT UNCLASSIFIED	18. SECURITY CLASSIFICATION OF THIS PAGE UNCLASSIFIED	19. SECURITY CLASSIFICATION OF ABSTRACT UNCLASSIFIED	20. LIMITATION OF ABSTRACT UL	

TABLE OF CONTENTS

1.0 EXECUTIVE SUMMARY	1
2.0 GIESIM PHASE I	2
2.1 GIESim Phase I Goals	2
2.2 GIESim Phase I Participants	2
2.3 GIESim Phase I Accomplishments	2
2.3.1 <i>Compile and Summarize the Capabilities of Candidate Simulation Tools</i>	2
2.3.2 <i>Map Simulation Tools into GIESim and JBISim Architecture</i>	3
2.3.3 <i>Define Roles and Interactions of the Candidate Simulation Tools</i>	4
2.4 GIESim Phase I Recommendations	5
3.0 GIESIM PHASE II	7
3.1 GIESim Phase II Goals	7
3.2 GIESim Phase II Participants	7
3.3 GIESim Phase II Accomplishments	7
3.3.1 <i>Technical Exchange Meeting</i>	8
3.3.2 <i>Technical Exchange Meeting II</i>	9
3.3.3 <i>Bi-weekly Teleconferences</i>	11
3.3.4 <i>SAB Posters</i>	13
3.3.5 <i>SAB Summary</i>	16
3.4 GIESim Phase II Recommendations	16
4.0 GIESIM PHASE III	17
4.1 GIESim Phase III Goals	17
4.2 GIESim Phase III Participants	17
4.3. GIESim Phase III Accomplishments	17
4.3.1 <i>Physical Architecture (Step #1)</i>	18
4.3.2 <i>Logical Architecture (Step #2)</i>	18
4.3.3 <i>Simulation Interfaces (Step #3)</i>	19
4.3.4 <i>JTIDS Simulation Model Enhancements</i>	20
4.3.5 <i>Scenario Design and Mission Goals (Step #4)</i>	21
4.3.6 <i>Planning and Network Design (Step #5)</i>	23
4.3.7 <i>Component Integration (Step #6)</i>	25
4.4 GIESim Phase III Operation Scenarios	26
5.0 LESSONS LEARNED	28
5.1 Criticality of Subject Matter Experts	28
5.2 Communication Scenarios	28
5.3 JSAF Software Complexity	28
5.4 GIESim-JSAF Software Application Integration	28
6.0 PROPOSED FUTURE WORK	29
6.1 GIESim/JSB-RD Additional Effort	29
6.2 Airborne Network	29
6.3 Optical & RF Combined Link Experiment (ORCLE)	29
7.0 REFERENCES	30
8.0 ACRONYMS	31

LIST OF FIGURES

Figure 2-1.	GIESim and JBISim Architecture.....	4
Figure 2-2.	Simulation Tools Interaction.....	5
Figure 2-3.	Force-level and Physics-based Simulation	6
Figure 3-1.	Proposed GIESim Physical Architecture	10
Figure 3-2.	Function Representation	10
Figure 3-3.	Scientific Advisory Board Preparation	11
Figure 3-4.	UAV Fight Path and High Value Target.....	12
Figure 3-5.	Korea and CONUS Connectivity.....	13
Figure 3-6.	Three-D View of Satellite Configuration.....	13
Figure 3-7.	GIESim Concept.....	14
Figure 3-8.	GIESim Phase II Scenario Description.....	15
Figure 3-9.	GIESim Future Research Activities	16
Figure 4-1.	Steps for GIESim/JSB-RD Software Merger.....	17
Figure 4-2.	GIESim-JSAF Physical Architecture.....	18
Figure 4-3.	JSAF Platform Position Updates into JTIDS	18
Figure 4-4.	Message Transmission Request and Response	19
Figure 4-5.	Communications Message Handling	20
Figure 4-6.	Enhanced JTIDS Message Handling	21
Figure 4-7.	Hierarchical Layers in Scenario Development	22
Figure 4-8.	SOF, STRIKER, UAV Relay, Time Sensitive Target, and Threats in the “Wow” Scenario.....	23
Figure 4-9.	PSI Link-16 Network Management System	24
Figure 4-10.	Integration of JSAF and JTIDS Simulations.....	25
Figure 4-11.	SOF, STRIKER, UAV Relay, Time Sensitive Target and Threats in the “Wow” Scenario	27

LIST OF TABLES

Table 3-1.	SAB Scenarios	12
Table 4-1.	Communications Message Handling	20
Table 4-2.	“Wow” Scenario JTIDS Networks	24

1.0 EXECUTIVE SUMMARY

This technical report summarizes the work accomplished in the performance of the GIESim communications Modeling and Simulations project. This work was performed by Syracuse Research Corporation (SRC), Science Applications International Corporation (SAIC), Prediction Systems, Inc. (PSI) and Frontier Technology, Inc. (FTI) for the Air Force Research Laboratory (AFRL), Distributed Information Systems Branch (IFGA), under Contract F30602-03-C-0074, in accordance to Contract Delivery Requirement List (CDRL) A003.

The objective of the effort was the integration of communications and network modeling and simulation (M&S) toolkits into the Global Information Enterprise (GIE) Modeling and Simulation (GIESim) framework for effective and efficient user analysis of candidate communications architectures and technologies.

The three-phased effort commenced in July 2002 and concluded in February 2005. Phase I had three major Goals:

- Compile and Summarize the Capabilities of Candidate Simulation Tools
- Map Simulation Tools into the GIESim and Joint Battlespace Infosphere (JBI) Simulation (JBISim)
- Define the Roles and Interactions of the Candidate Simulation Tools

Phase II of this effort was the integration of communications and network modeling and simulation (M&S) toolkits into the Global Information Enterprise (GIE) Modeling and Simulation (GIESim) framework. This phase was a simulation development program to further define, design, and implement a Modeling and Simulation (M&S) framework for GIE and was developed in a contractor and government team environment that brought together M&S and subject area expertise.

Phase III was the merging of the GIESim Joint Tactical Information Distribution System (JTIDS) simulation with the Joint Semi-Automated Forces (JSAF) project. The GIESim JTIDS added tactical communications modeling to JSAF. Also the merger of the JTIDS/Link-16 capabilities from GIESim with JSAF was a first step toward applying the GIESim rapid communications modeling approach to a large simulation environment. Of equal importance in GIESim Phase III was the Modeling and Simulation (M&S) demonstration between JSAF and GIESim JTIDS that tested the interoperation and that had a direct impact on an observer.

Sections 2, 3, and 4 summarize GIESim's Phase I, II, and III respectively, including their goals, participants, accomplishments, and recommendations for the effort. Section 5 provides a synopsis of the GIESim-JSAF demonstration. Section 6 provides Lessons Learned while Section 7 provides ideas for proposed future work.

2.0 GIESIM PHASE I

2.1 GIESim Phase I Goals

The three major Goals of the GIESim Phase I commenced in July 2002 and concluded December 2002. The following tasks were included:

- Compiled and Summarized the Capabilities of Candidate Simulation Tools
- Mapped Simulation Tools into the GIESim and JBISim Architectures
- Define the Roles and Interactions of the Candidate Simulation Tools

Working closely with AFRL the team developed an overall GIESim architecture. SRC's familiarity and direct experience with many of the candidate simulation tools offered a unique opportunity to provide broad guidance in developing the GIESim framework.

2.2 GIESim Phase I Participants

During Phase I of the program, the Modeling and Simulation team of Syracuse Research Corporation (SRC), Science Applications International Corporation (SAIC), Prediction Systems, Inc. (PSI), and Frontier Technology, Inc. (FTI) worked closely with AFRL/IFGC (Information Connectivity Branch) on the effort.

2.3 GIESim Phase I Accomplishments

2.3.1 *Compile and Summarize the Capabilities of Candidate Simulation Tools*

To understand how simulation tools may be used to simulate the GIE and JBI, it was essential that a single compilation of the simulation tool capabilities be generated. Many of the candidate tools were studied under the Satellite Communications System Simulation Phase I SBIR program for operation with the Communications Analysis and Simulation Toolkit (CAST). The tools selected were as follows:

1. **OPNET** is a discrete event simulator environment used to simulate and analyze hierarchical network models with integrated analysis and animation tools. Licenses are sold at various levels of user complexity. There are multiple "guru" products that are for analyst and planner level users. They come with model libraries and allow the user to "drag and drop" models to create networks to analyze. OPNET modeler allows the user to modify models and create them from scratch as well as having the capabilities of the "guru" level products. For developers who want access to the software design tools of OPNET, the OPNET Development Kit (ODK) is available. It allows access to OPNET's software development tools and has all the functionality of a modeler. OPNET has a large user base with a strong presence in the military community. They have a comprehensive library of detailed equipment, protocol, and application models including vendor-specific equipment models. As does any of the more powerful network simulation tools, OPNET has a large learning curve for new users. To use OPNET effectively, users are required to invest time in training and practice. With the wireless add-on module, OPNET has the capability to model wireless and satellite links. Much of the work done in wireless using OPNET has been done in classified domains making it difficult to find many readily available wireless models.
2. **NETWARS** is a communications modeling tool being developed by OPNET for DISA. Its purpose is to enable the warfighter to credibly model tactical and operational communications demands with all the stresses that combat places on communications systems. The main objective of NETWARS is to provide an integrated ability to analyze communication networks; a corollary objective is to provide validated simulation capability with asset and information exchange requirement (IER) model databases. NETWARS is designed to quantify the risks and identify C4 deficiencies before US Forces are committed into any contingency. To achieve this end, NETWARS will evaluate the risks of planned communication networks that will be supporting warfighter operations by factoring in movement, environmental factors and terrain effects. NETWARS development is currently focusing on model interoperability (i.e., standards), customer

support and training, improved realism, expanding the model library, improved usability, operational test and evaluation (OT&E), and better documentation.

3. **Satellite Tool Kit (STK)** is a suite of software modules produced by Analytical Graphics, Inc. (AGI) to analyze satellite assets and orbits, integrated land/sea/air/space systems, communications links, and 3-D models. STK has developed high precision, validated, orbital propagation models. It is extremely powerful for dynamic analyses that involve determining access between two or more objects. With the visualization option (VO), STK can create stunning animated 3-D visualizations. The STK user interface is intuitive and fairly easy to learn to use. STK is limited to the physical layer analyses. It has very limited networking capabilities and has no user-defined modeling capabilities.
4. **General Simulation System (GSS)** is a visual CAD environment produced by Prediction Systems, Inc. (PSI) to support Model Development, Scenario Development, Simulation, and Analysis. PSI provides custom simulations tailored to customer needs. GSS is provided to all customers without licensing costs. It is able to provide solutions quickly by reusing and modifying models from its large archive. Customers receive all the source code for their simulations and models and can modify it as they wish. The source code is written in a CAD-type environment which helps document the simulation architecture. GSS simulations tend to run quickly and allow users to interact graphically with the simulation as it is running. For example, in one of their JTID simulations, the user starts the simulation and can view the connectivity of the network. While the simulation is running, the users can move radios around and add new radios and immediately see how the connectivity is affected. GSS is not flashy COTS type software with generalized drag and drop libraries for doing network simulations. GSS requires an experienced user to make effective use of the tool.
5. The **Network Simulator (Ns-2)** is an object-oriented simulator targeted at networking research that provides substantial support for simulation of TCP, routing, and multicast protocols over wired and wireless (local and satellite) networks. Ns-2 compiles under UNIX, Linux, and Windows. The simulator is open source and can be rewritten as needed.

There is a large supply of free contributed code and models for Ns-2. The contributed code covers the areas of routing, mobility, wireless, satellite, topology and traffic generators, scheduling and queue management, multicast, transport, and support. Animations of Ns-2 simulations can be recorded with another software tool called the Network Animator (NAM).

Ns-2 is not a finished and polished product. Ns-2 has validation tests that cover many protocols. However, users are responsible for verifying that Ns-2 is accurate for their purposes.

6. **SPEEDES** simulation engine allows the simulation builder to perform optimistic parallel processing on applications that are typically time-constrained (too many events to process in a limited amount of time). In optimistic parallel processing, each processor simulates its objects as quickly as possible. If an event occurs that affects an object on another processor (processor B) it (processor A) notifies that processor of the event. In the case where processor B has already moved on to a simulation time past the simulation time of the incoming event, processor B will rollback only those objects affected by the event. This algorithm improves the speed of the simulation over a parallel processing algorithm that requires that all processors stay synched up in simulation time. **SPEEDES** has been designed to implement High Level Architecture (HLA). **SPEEDES** does not include a model library of communication/network devices or protocols. There are no “drag and drop” interfaces for building networks to be simulated. **SPEEDES** requires an experienced user/programmer in order to effectively use this tool.

2.3.2 Map Simulation Tools into GIESim and JBISim Architecture

Figure 2-1 outlines the GIESim conceptual architecture. The complete scenario is provided as three separate parts: mission (Scenario), equipment (Device and Protocol Database), and doctrine (Thread/IER Database). These three parts are compiled and linked together by the Intelligent Scenario Compiler to form a complete simulation. A force-level simulator will provide realistic scenarios. Input of these scenarios may be automated or require assistance from

the user through the user interface. The Device & Protocol Database will provide the necessary equipment and protocol models necessary to run the simulation. The Thread/IER Database will provide the traffic and operational procedure models.

The Intelligent Simulation Interface determines what simulators are necessary to run the simulation. It then coordinates the efforts of the federation of simulators in order to provide results to the Performance Evaluation portion of the architecture. Communications between federation members will take place through HLA interfaces.

The Performance Evaluation process takes the various outputs from the federation and converts these dissimilar results into coherent and compatible Measures of Merit (MoM). If GIESim is being used “in the loop” by a force-level simulations, the MoMs can be sent back as the required information object. For off-line simulations, the MoM may be used to create high fidelity network abstractions. The MoM may also be used by the user or optimization routine to do iterative runs of the simulation for optimization purposes.

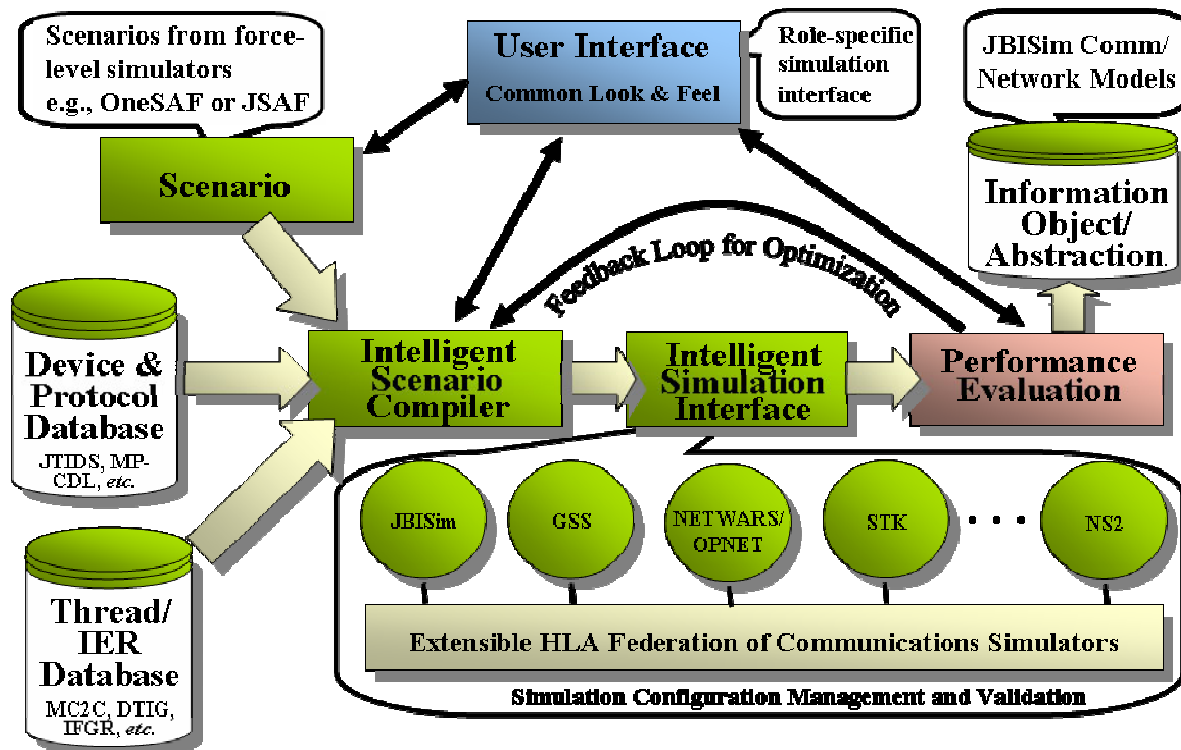

Figure 2-1. GIESim and JBISim Architecture

2.3.3 Define Roles and Interactions of the Candidate Simulation Tools

Figure 2-2 illustrates several GIESim simulation tools, their potential interactions, and the relative user sophistication required to effectively operate the programs.

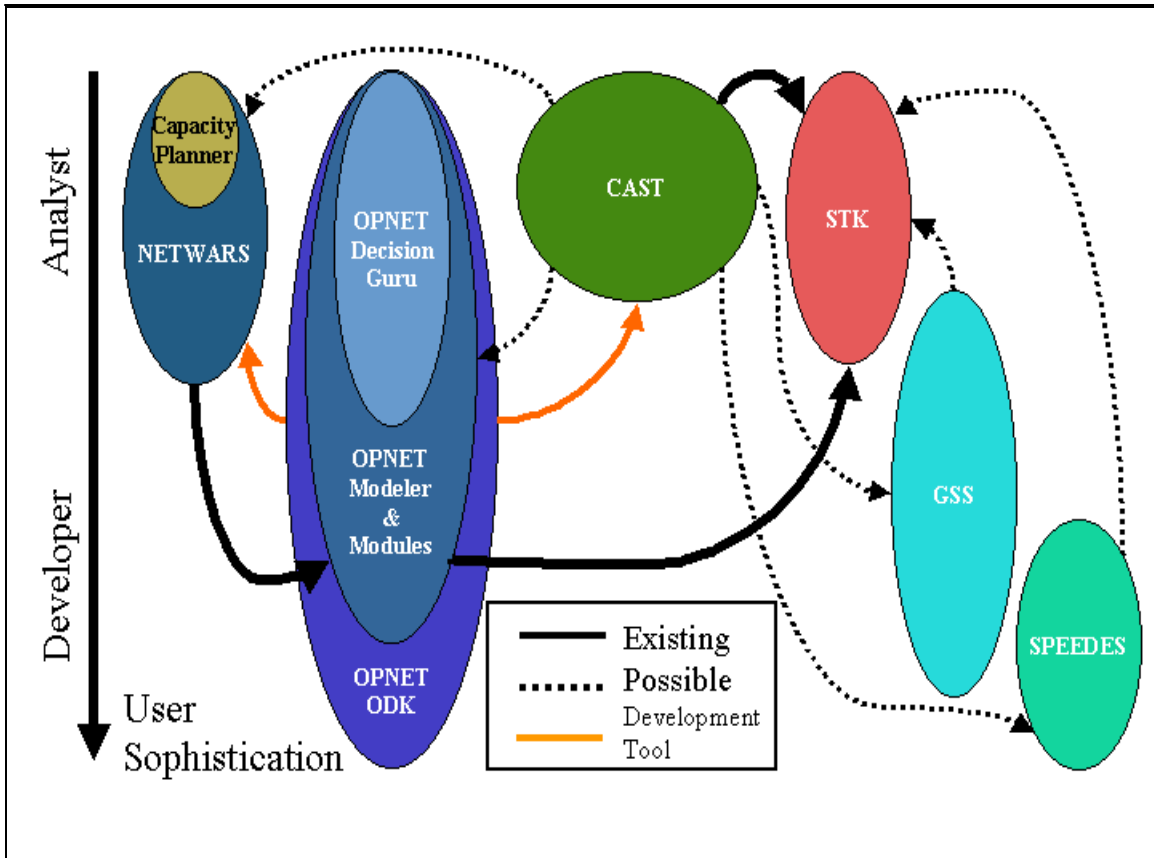

Figure 2-2. Simulation Tools Interaction

In Figure 2-2 the oval shapes represent the candidate tools and ovals nested within the larger ovals indicate tools that are subsets of the larger package. For example, the OPNET Decision Guru is an OPNET tool that offers a subset of the features available in the OPNET program; likewise, the OPNET Development Kit (ODK) is a development environment that may or may not use features of the OPNET Modeler program to implement simulation programs. The height and vertical position of the oval provides an indication of the program's required user sophistication to operate the program; the width and horizontal position of the oval have no comparable meaning.

The arrows in Figure 2-2 show the existing (heavy black) and possible (dashed black) interaction between the candidate programs. For example, NETWARS uses the OPNET Modeler program (OPNET add-on modules) for processing; in turn, OPNET Modeler uses an STK processing kernel for mobile communications nodes. As indicated by multiple dashed lines, the CAST program is being developed to provide a common user interface to multiple simulation and analysis tools. The orange arrows indicate that the NETWARS and CAST tools are developed using ODK.

2.4 GIESim Phase I Recommendations

The Phase I GIESim modeling and simulation environment tended to have a disconnect between force-level and physics-based simulations. Force-level simulations generally have low fidelity models to represent communications. Often, the force-level simulations assume the communications always work. This can lead to invalid simulations. An example would be an air asset radioing in a strike message against an enemy target without a high fidelity comm. simulation. The call is assumed to be successful and the target would be destroyed. However, it may be the case that a high level comm. simulator would show that terrain would block the strike message. This would change the results of the force-level simulation since now the enemy target would not be destroyed. This change can potentially have a large domino effect on the force-level simulation as it continues to interact with the simulation. If it was a weapon system, it may go on to destroy entities that would not have otherwise been destroyed. If it is a high priority target, it may cause the air asset to change course in order to ensure that the strike message gets through.

The capabilities to model the necessary communications assets exist but this capability has not been integrated in any significant way with force-level simulations. For the next Phase of the effort, it was proposed that GIESim encompass (see **Figure 2-3**), both force-level and physics-based simulations, thereby bridging the gap and melding the capabilities of these two types of simulation.

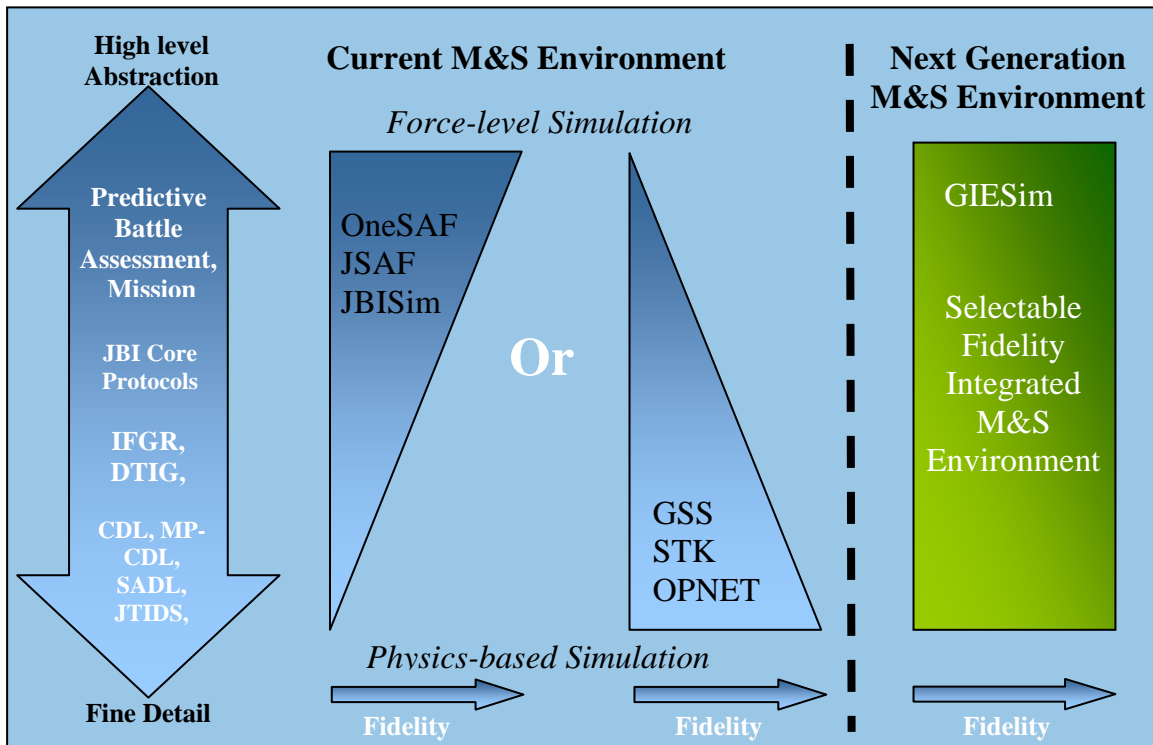

Figure 2-3. Force-level and Physics-based Simulation

3.0 GIESIM PHASE II

3.1 GIESim Phase II Goals

The primary goal of this effort was the integration of communications and network modeling and simulation (M&S) toolkits into the Global Information Enterprise (GIE) Modeling and Simulation (GIESim) framework for effective and efficient user analysis of candidate communications architectures and technologies. The GIESim is a simulation development program to define, design and implement a Modeling and Simulation (M&S) framework for GIE. It was developed in a team environment that brought together M&S and subject area expertise. The GIESim team included companies and Air Force (AF) groups with the experience necessary to leverage existing experience and emerging communications models. The GIESim included Air Force Research Laboratory (AFRL) employees at the Rome and Wright Patterson Research Sites, large and small companies, and academia.

3.2 GIESim Phase II Participants

Air Force Research Laboratory, Information Directorate, Information Grid Division, Distributed Information Systems Branch (AFRL/IFGA) has provided superior management and leadership to the GIESim project leading to successful project R&D technology and demonstrations. IFGA's charter is to identify and develop technologies to enable a distributed information infrastructure that provides all the mechanisms and services required to allow the warfighters to craft their C4I information environments. Specific technologies include: network protocols, information adaptation, network management, routing technologies, adaptive interfaces, distributed information environments, multimedia services, adaptive security services, global resource management, and architectures.

Prediction Systems, Inc. (PSI) has been involved with the development of the GIESim project in all phases of the effort. PSI provided senior software engineering staff members with robust knowledge in military communications networking including Joint Tactical Information Distribution System (JTIDS) communication, Department of Defense (DoD) M&S, High Level Architecture (HLA), GIESim development, integration and demonstration, development of force-level and tactical communication scenario generation, and software integration. Also, PSI is the developer of the General Simulation System (GSS) which provides a complete facility for building models and running simulations of general dynamic systems. GSS is a key component of the GIESim software architecture.

Science Applications International Corporation (SAIC) has been involved with the development of the GIESim project since its inception. SAIC provided senior software engineering staff members with hands-on experience and knowledge in DoD M&S, High Level Architecture (HLA), JSAF software development and integration, GIESim development, and software integration.

Syracuse Research Corporation (SRC), like PSI and SAIC, has been involved with the development of the GIESim project from the beginning. SRC has provided both force-level and tactical communication scenario generation development with staff that are mission-specific subject matter experts having served within the Air Force and other services. SRC has provided technical management direction and guidance throughout all phases of the GIESim development. Having technical experience with OPNET (a network simulation tool) SRC aided with the development of the successful Scientific Advisory Board (SAB) related tactical demonstration scenarios.

3.3 GIESim Phase II Accomplishments

The GIESim Phase II Team was comprised of SRC, SAIC, PSI and AFRL. The following tasking activities were achieved.

- Supported AFRL in the evaluation of communication simulation technologies and applications.
- Generated realistic scenarios to test the GIESim architecture.
- Aided AFRL in the development and execution of the GIESim program plan.
- Provided direction and support for the SAB review.

The paragraphs to follow provide details on the tasking activities that lead up to the SAB presentation and review process.

3.3.1 Technical Exchange Meeting

SRC led organizing the Technical Exchange Meeting (TEM) in AFRL Building 3 on May 14, 2003. The meeting was attended by Dr. Warren Debany, and Richard Smith from AFRL; Marty Ragusky, Jim Periard and Joe Lauko from SRC; Jerry Reaper from SAIC; and John Fikus from PSI. The primary area of discussion centered on the Scientific Advisory Board (SAB) demonstration and the planning and execution necessary to reach that demonstration. Topics covered included the following areas:

- Goals & Objectives
- SAB Demo Requirements
 - Must haves, nice to haves
 - Data Collection Requirements
 - Analysis plans
 - Contingency plan(s)
 - Use case walk through
 - User interface (GSS, MIST STK, etc.)
- Scenario Requirements (NE Asia, i.e., Korea 2010, JBI TCT)
 - Must haves, nice to haves
 - Required behaviors & products of each scenario element (e.g., what the JSTARS does, how & why it does it, what it produces)
 - Required traffic sources and patterns GIESim Architecture
 - List of federates, their function in the demo, and their requirements
 - Inputs/outputs
 - Data collection requirements collected
- Partitioning of scenario responsibilities
 - HLA RTI-NG
 - HLA Federation Object Model (FOM)
 - User interface (GSS, MIST STK, etc.)

The focus of the meeting was to kick off the Phase II effort which was centered on preparing a realistic demonstration of the GIESim capability for the November 2003 SAB visit to AFRL Rome Research Site. The simulation approach that was discussed involved integrating the following tools using the High Level Architecture (HLA) backbone interface present on the GIESim and the JBI Simulations. Components of the simulations are as follows:

- JBI Simulation from AFRL
- OPNET (ISR Simulation) from SAIC
- GSS (JTIDS) and STK from PSI

The demonstration components included PSI's GSS/JTIDS model. This offered a realistic model of the tactical network, its limitations, and capabilities. Analytical Graphics, Inc., commercial product, STK, was used to model SATCOM geometries. The OPNET network modeling tool to do an ISR simulation that SAIC had been working and the Joint Battlespace Infosphere (JBI) simulation to help manage network traffic.

By linking these products the GIESim SAB demonstration would show message traffic going from ISR platforms through analysis centers to command and control platforms and finally to shooters on target. The message traffic would use a publishing/subscribing protocol in JBI. By leveraging the GSS/JTIDS simulation analysis could be done showing limitations in the communications network based upon:

- Degradations in a SATCOM link
- bandwidth limitations (i.e., predator)
- Constellation geometry (satellites)

There was also discussion related to who was going to use GIESim and what it was going to be used for. The general consensus was that GIESim is a framework to perform analysis or, in other words, a tool to collect Measures of Performance (MOP) and Measures of Effectiveness (MOE) for different communication configurations and parameters.

3.3.2 Technical Exchange Meeting II

A second Technical Exchange Meeting (TEM) was held on June 19, 2003 to further define what was to be demonstrated for the SAB. The highlights of the meeting were:

- SRC led a discussion on CONOPS and Scenario.
- Prediction Systems Incorporated briefed their GSS modeling tool and talked about the GIESim Architecture.
- SAIC talked about their OPNET modeling efforts and how it fit into the proposed GIESim Architecture.
- AFRL also discussed the role of JBI in the GIESim demonstration.

Some of the fundamental questions discussed at the TEM were:

- Why does the user care that GIESim exists?
 - The complex communication scenarios that GIESim can analyze require multiple simulation applications to run in a coordinated fashion. There is no single simulation to address complex communication issues and tradeoffs. To address this, GIESim explored architecture/framework options for integration of multiple tools capable of operating at multiple fidelity levels.
 - In many analyses communication bandwidth and connectivity is taken for granted. GIESim provides a tool to add the detail required for realistic analysis. Part of this analysis would include latency measurements through a multi-level communication system.
- What is the science we are showing?
 - Solving complex communications problem sets.
- Who are the users?
 - The proposed users of GIESim are Network planners.
- What problems are we solving?
 - Developing complex simulation applications is very expensive and, in many cases, duplicates existing efforts with slight variations to address specific user needs. GIESim reduces the cost of simulation by developing an architecture/framework for the integration of multiple existing simulation tools.
 - GIESim assists in the planning for networking, communications, and bandwidth demands seen in complex communication scenarios.
 - GIESim also provides a testbed for the evaluation of JBI infrastructure.

The components of Phase II GIESim are outlined as:

- Joint Battlespace Infosphere (JBI)
 - JBI defines an information management structure for:
 - Traffic patterns and throughput requirements
 - Each unit has defined publish/subscribe capabilities.

- GSS system for JTIDS simulation.
- OPNET to be used to simulate Unmanned Aerial Vehicles (UAV) communication.
- STK to model satellite communication asset orbitology.

Some of the points to be demonstrated for the SAB were a disruption of a network due to the dropping or disruption of a communication node. After disruption GIESim will show a redistribution of traffic and provide a quick-look analysis.

The proposed GIESim physical architecture was designed as shown in **Figure 3-1** below.

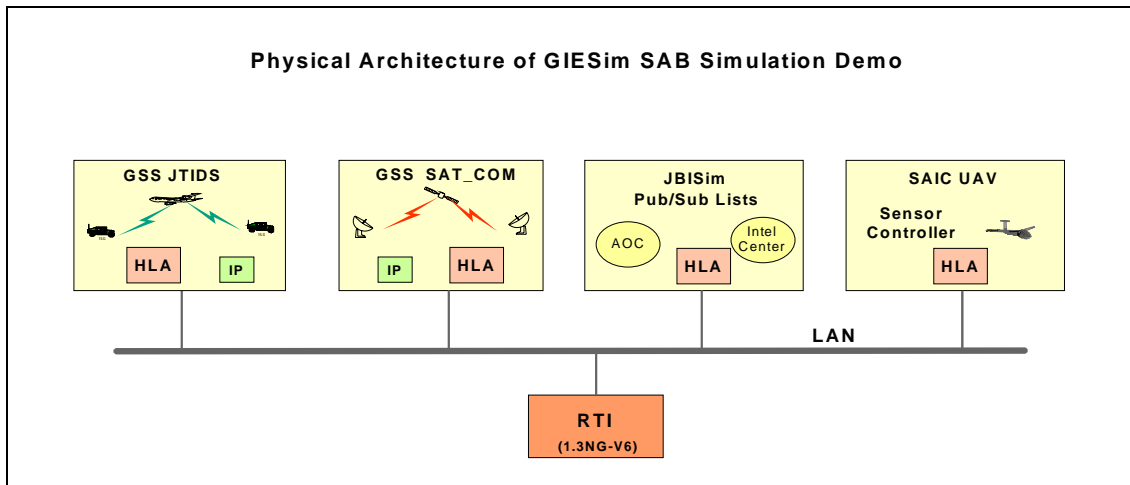

Figure 3-1. Proposed GIESim Physical Architecture

A functional representation, shown below in **Figure 3-2**, was also discussed.

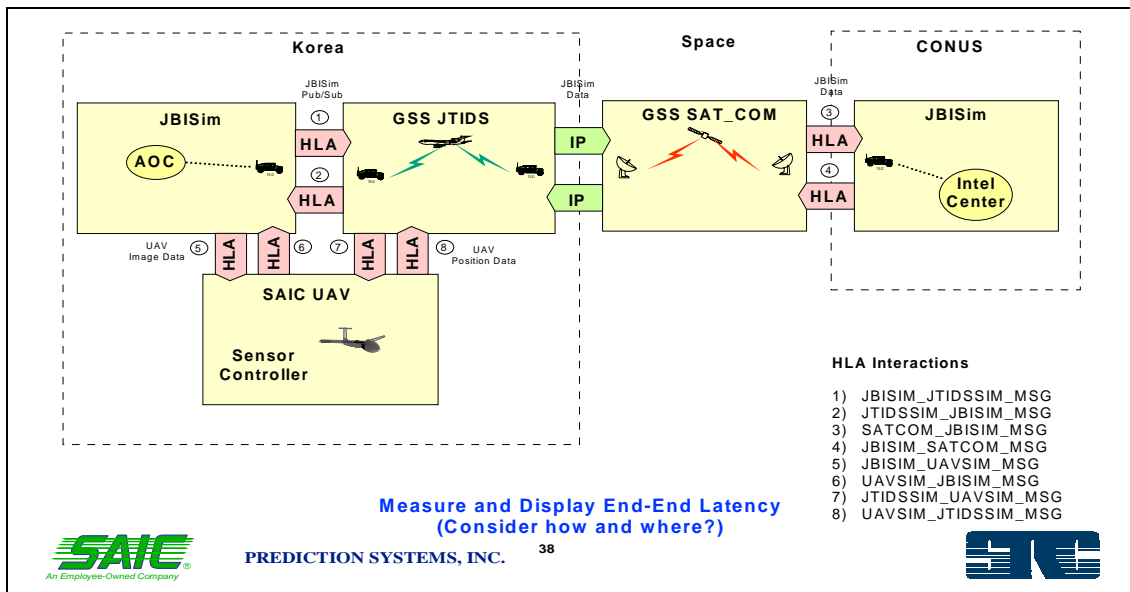

Figure 3-2. Function Representation

A proposed communication scenario to show to the SAB was also presented as depicted in **Figure 3-3**. The scenario was to include a UAV flying over Korea reporting data (an image) back to a CONUS ground exploitation site. After exploitation at the ground site, information is forwarded back to command and control in theater and subsequently on to a shooter. GIESim would demonstrate the limitations of the communications architecture and provide alternatives and tradeoffs.

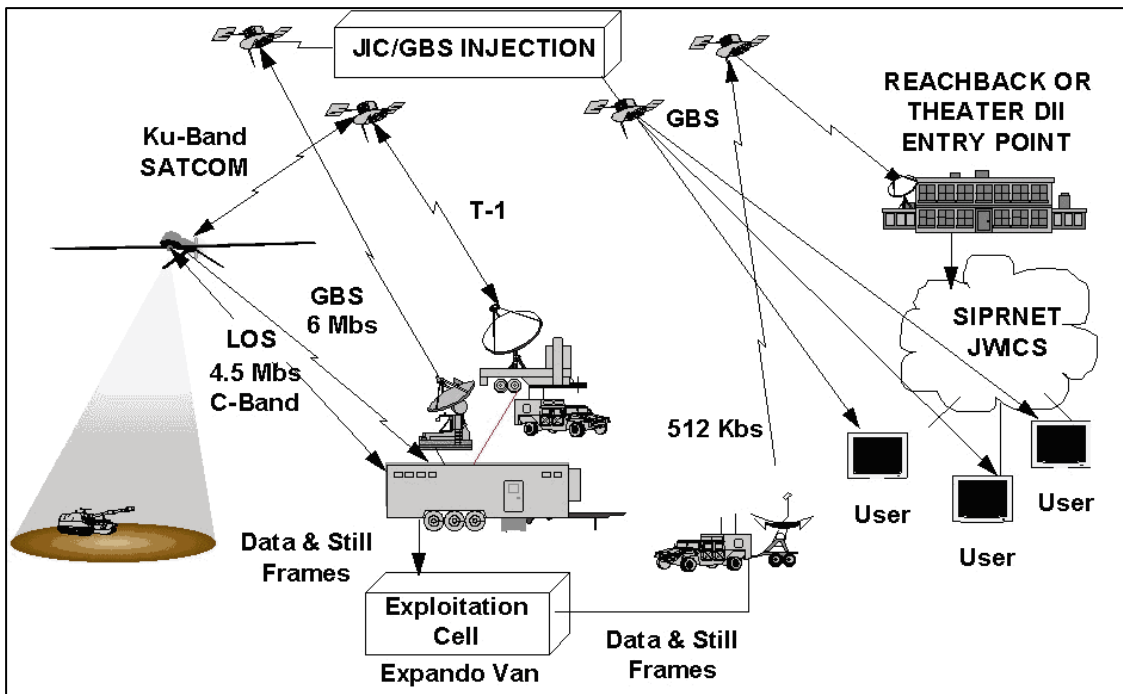

Figure 3-3. Scientific Advisory Board Preparation

3.3.3 Bi-weekly Teleconferences

Starting in July of 2003, SRC initiated bi-weekly teleconferences to discuss the demonstration and software preparation for the scientific board presentation. An initial development schedule was proposed as follows:

- Initial description of SAB demo July 17
- GSS/OPNET Integration via Internet A July 24
- Revised description of SAB demo July 24
- GSS/OPNET Integration via internet B July 31
- Final description of SAB demo July 31
- Dry run SAB demo at Rome Aug 7
- Final pre-AFRL dry run Aug 21
- Demo to AFRL for SAB decision Sept. 1

Three different scenarios, as presented in **Table 3-1** below, were proposed and worked in the teleconferences. Scenario 2 was selected.

Scenario 1	Scenario 2	Scenario 3
Image downlinked to AOC compound at Osan	Image downlinked to AOC @ Osan	Image sent from UAV to Beale via SATCOM uplink
	Link 16 relay from control van to SATCOM link	
Image analysis done at Osan	Sent to Beale via SATCOM	Image analysis done @ Beale
	Link 16 relay from SATCOM to AOC	
Strike message sent from AOC to fighter via JTIDS	Image analysis done @ Beale	Annotated Image from Beale to Osan via SATCOM
	Annotated Image from Beale to Osan via SATCOM	Strike message sent from AOC to fighter via JTIDS
	Strike message sent from AOC to fighter via JTIDS	

Table 3-1. SAB Scenarios

SRC used the STK to prepare mockups of the scenarios and proposed flight paths of the scenario actors. **Figure 3-4** shown below presents the UAV flight path and high value target vehicle track. This image also shows the Osan AOC downlink site for the UAV.

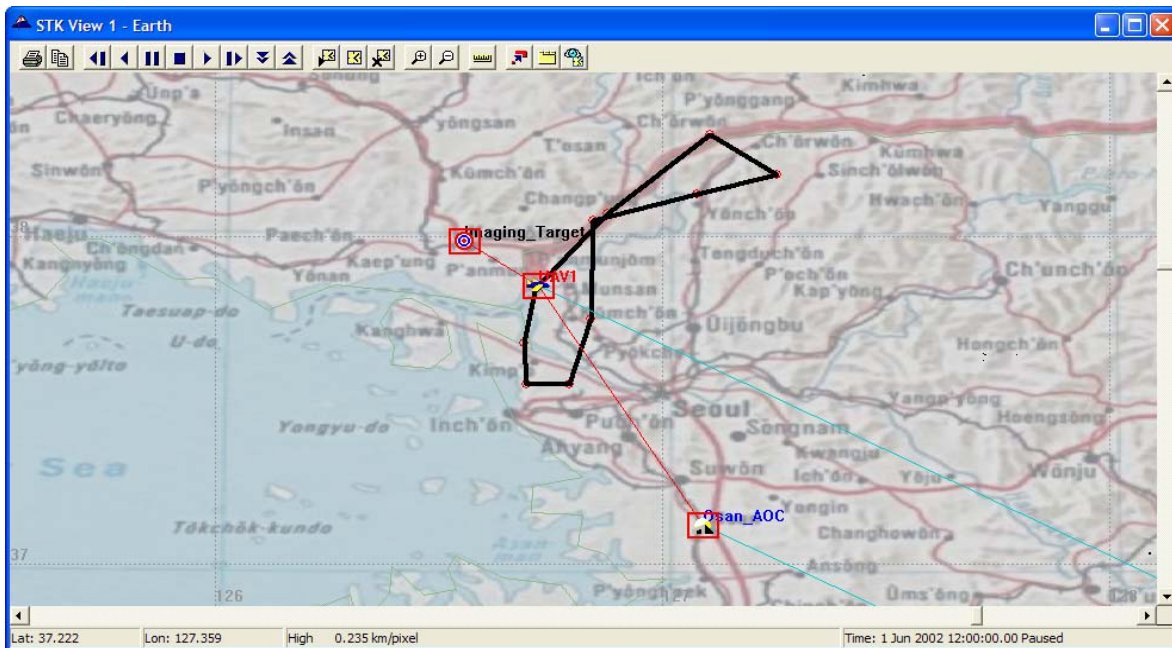

Figure 3-4. UAV Fight Path and High Value Target

The second image, **Figure 3-5** shows the connection between the theater, in this case Korea, and two CONUS exploitation sites, one at Beale and one at Langley. The connections to CONUS require SATCOM to be employed. Beale requires a single satellite connection and Langley a two-hop connection.

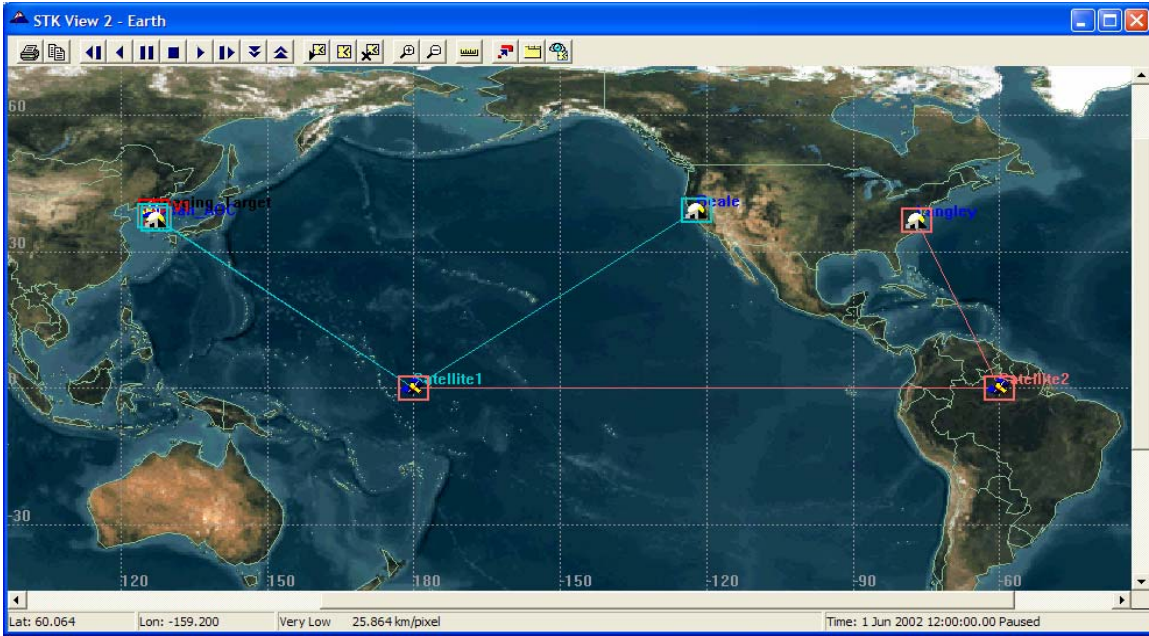

Figure 3-5. Korea and CONUS Connectivity

The third diagram, **Figure 3-6**, shows a 3-D view of the satellite configuration.

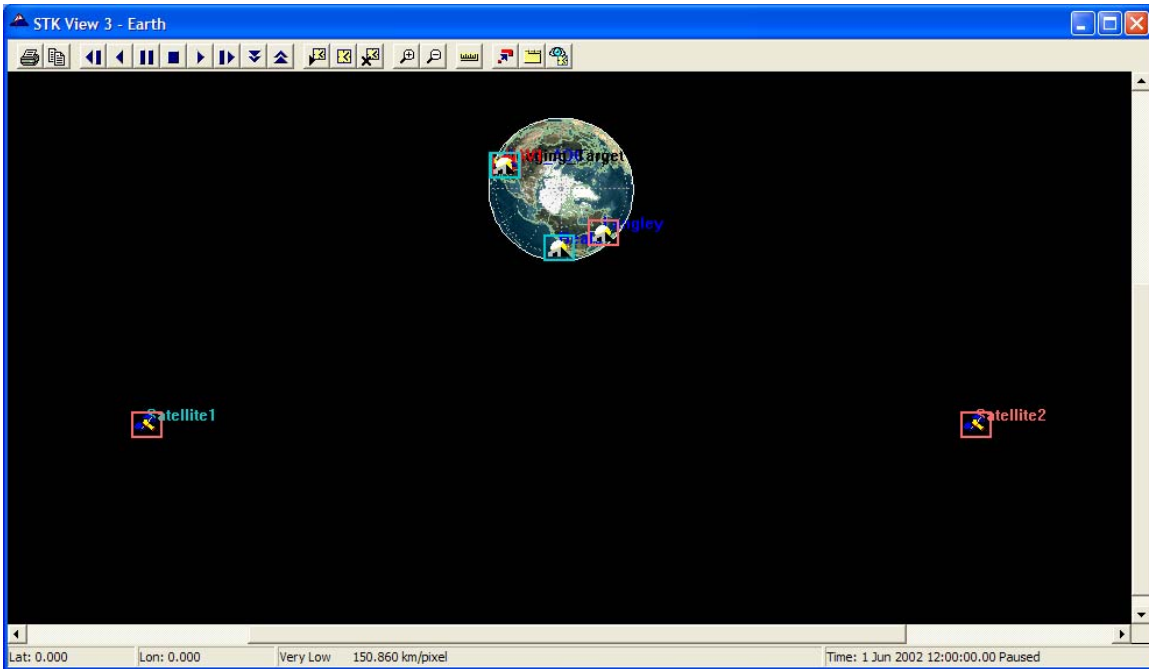

Figure 3-6. Three-D View of Satellite Configuration

3.3.4 SAB Posters

GIESim posters were also developed and worked in the teleconferences. It was decided that three posters were to be made. The first poster **Figure 3-7** below outlines the GIESim concept, a high level peek at a CONOPS, and an overview of the GIESim framework.

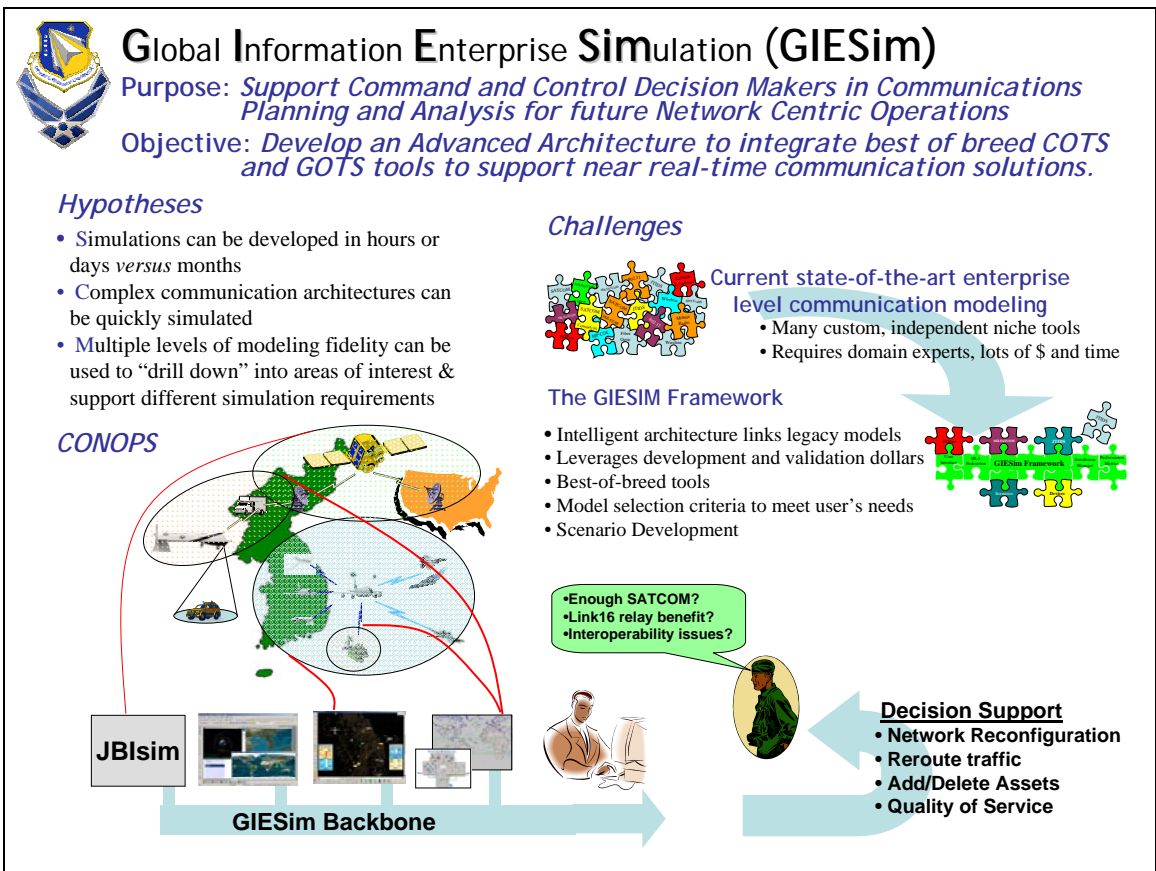

Figure 3-7. GIESim Concept

The second poster, **Figure 3-8**, is a description of the GIESim scenario demonstrated for the SAB. The scenario is described from three view points: operational, communications, and an information object view.

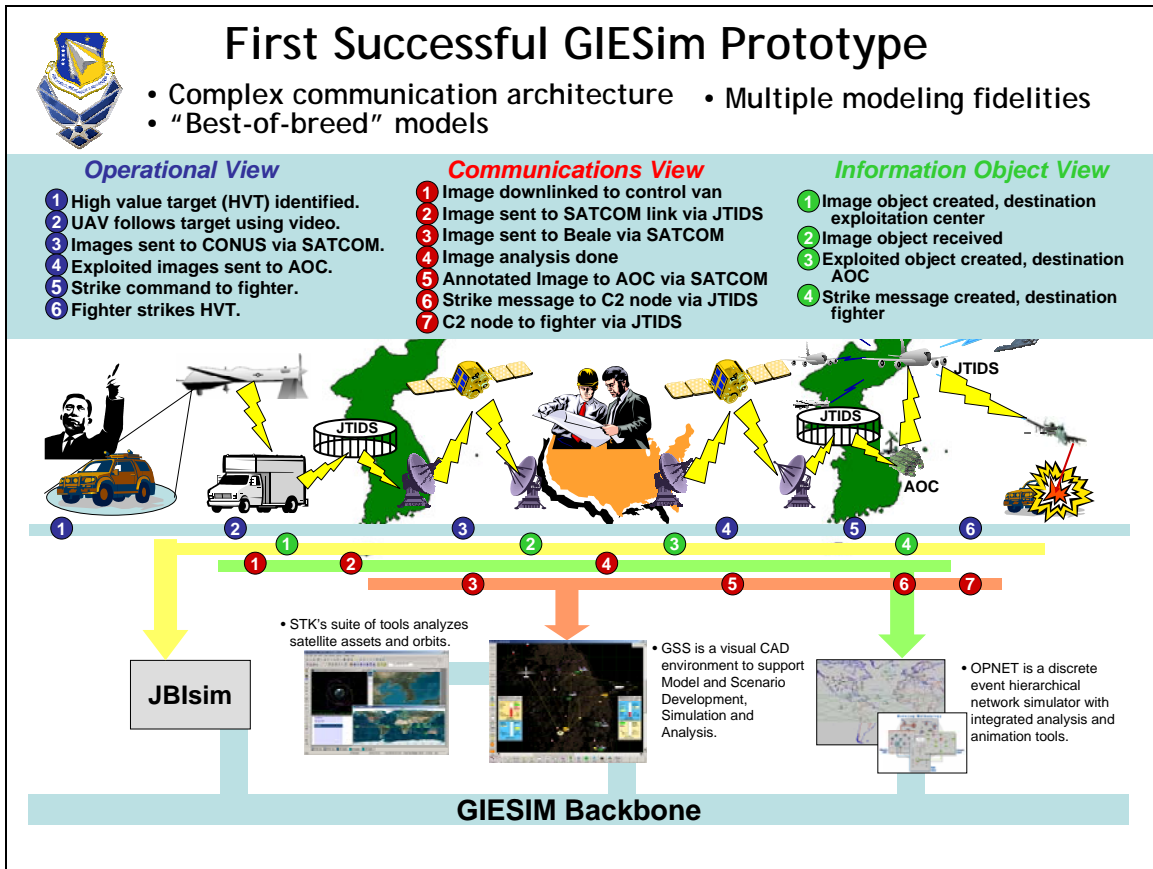

Figure 3-8. GIESim Phase II Scenario Description

The final poster, **Figure 3-9**, discusses proposed GIESim future research activities. The two major topic areas discussed in the final poster were lessons learned and future research areas. The lessons learned included:

- Order of magnitude less costly to leverage existing simulations. GIESim successfully demonstrated the analysis of a complex communications architecture. This analysis would have been extremely costly if started from scratch. By leveraging existing simulation technology and integrating these capabilities together, a useful analysis could be done quickly with relatively small investment.
- Use of simulation does not eliminate the need for subject matter experts. The use of the leveraged simulations and GIESim requires someone who understands communication issues and real-world limitations.
- Components require tailoring to integrate into GIESim. Much of the effort expended was spent customizing the existing tools to fit into the GIESim architecture. This proved relatively inexpensive but will be required for each existing technology that is leveraged.
- Scenario development effort should not be underestimated. The development of a realistic scenario proved non-trivial. Even though the basic concepts were discussed at early teleconferences, a significant amount of effort was expended refining the scenario.



GIESim Future Research Activities

Lessons Learned (FY03)

- 1 Order of magnitude less costly in dollars and time to leverage existing simulations
 - Use of existing simulations does not eliminate the need for domain experts
- 2 Model/components require tailoring to integrate into GIESim
- 3 Scenario development complexity should not be underestimated

Future Research Areas

- 4 Explore Customer/System Needs
- 1 Reduce the dependency on domain experts
- 1 Techniques to Speed-up Multi-Sim Development
- 5 Innovative Methods to Improve Sim Architecture
 - HLA Protocol
 - Web Services
 - Collaborative Environments
- 6 Standard Definition of Simulation Scenario
 - Communication Topology

Vision

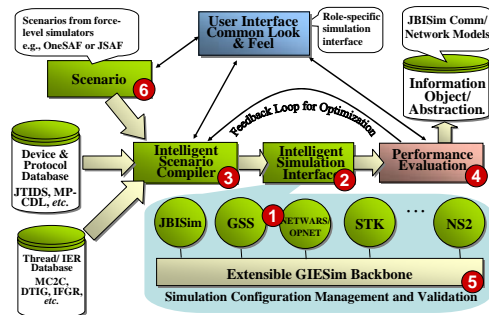

FY04 Lab/Demo Activities

GIESim Lab Development

- Develop GIESim multi-simulation lab

Demonstration Phase

- Develop DTIG Scenario
- Demonstrate Deployed Theater Information Grid (DTIG) in Multi-Simulation GIESim Environment

Figure 3-9. GIESim Future Research Activities

3.3.5 SAB Summary

The GIESim Phase II effort focused on producing a demonstration capability for the Scientific Advisory Board (SAB). The GIESim Team worked closely to define, develop, and deliver a successful demonstration; the SAB members responded favorably to the GIESim concept. During this phase of the effort, SRC provided assistance to AFRL with scenario design and development, Concept of Operation (CONOP) development, and the overall management of the software development efforts.

3.4 GIESim Phase II Recommendations

As stated and presented at the SAB, several GIESim future research areas were discussed and recommended. These recommendations are:

- Explore customer/system needs
- Reduce dependences on domain experts
- Develop techniques to improve simulation architecture
 - HLA Protocol
 - Web Services
 - Collaborative Environments
- Standardize simulation scenario definition
 - Communications topology

4.0 GIESIM PHASE III

4.1 GIESim Phase III Goals

The primary goal of GIESim Phase III was the merging of the GIESim JTIDS simulation with AFRL/IFGA Joint Semi-Automated Forces (JSAF) project. The GIESim JTIDS added tactical communications modeling to JSAF. Also, the merger of the JTIDS/Link-16 capabilities from GIESim with JSAF was a first step toward applying the GIESim rapid communications modeling approach to a large simulation environment. Of equal importance in GIESim Phase III was the Modeling and Simulation (M&S) demonstration between JSAF and GIESim JTIDS that tested their interoperability and had an impact on an observer. Lastly, an operational relevant scenario was developed to successfully demonstrate the value of adding communication modeling to the JSAF program.

4.2 GIESim Phase III Participants

The GIESim Phase III effort focused on the integration of GIESim communication simulation software with the Joint Semi-Automated Forces (JSAF) simulation software. To help keep continuity of the program, the Modeling and Simulation team of SRC, SAIC, PSI, and AFRL/IFGA continued to work closely on this final stage of the effort. SRC continued to provide both force-level and tactical communication scenario generation development. The staffs assigned to the program were mission-specific subject matter experts having served within the Air Force within key intelligence gather and analysis areas. Also, PSI continued to provide senior software engineering staff members with robust knowledge in military communications networking, DoD, M&S, HLA, GIESim development, integration and demonstration, development and force-level and tactical communication scenario generation, as well as software integration. SAIC provided additional stability to the effort with GIESim experienced senior software engineering staff members with, hands on and knowledge in DoD M&S, HLA, and comprehensive knowledge of the JSAF software development and integration program.

4.3 GIESim Phase III Accomplishments

Figure 4-1 represents the GIESim/JSAF merger requirements^[3] and the steps that the GIESim/JSB-RD team took in integrating the GIESim and JSB-RD software suites. This diagram was created to assist the team in maintaining focus on the sub-tasking that we had to follow to achieve this goal. The merger requirements were determined over several face-to-face team telecommunication meetings and e-mail exchanges. For the merger, this meant maximizing re-use of prior investments to minimize new developments and to speed realization of the merger, as well as starting with a simple, though effective, scenario.

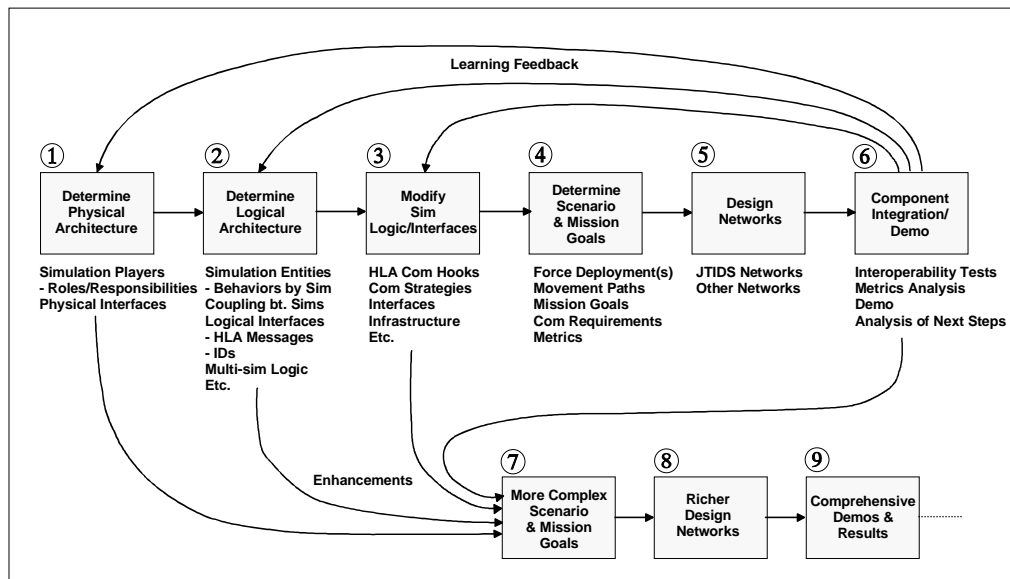

Figure 4-1. Steps for GIESim/JSB-RD Software Merger

4.3.1 Physical Architecture (Step #1)

To establish the physical architecture, the merger team had to select from several available GIESim components. Given that tactical communications was the most important component to add to JSAF, the team chose to use the JTIDS simulation from GIESim. This simulation would be interfaced to the main component of JSAF. This relationship is shown in **Figure 4-2**.

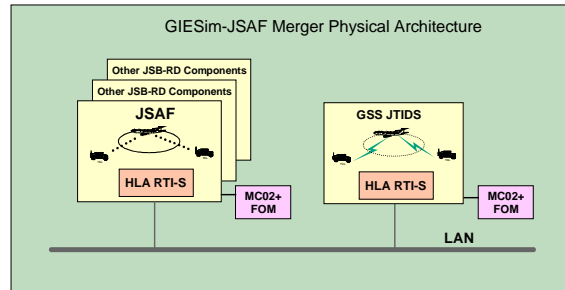

Figure 4-2. GIESim-JSAF Physical Architecture

Given that JSAF traditionally handles platform motion, we determined that JSAF would retain this role, whereas the JTIDS simulation would provide tactical communications modeling.

4.3.2 Logical Architecture (Step #2)

Step 2 was determination of the logical architecture of the merger. This entailed: 1.) an analysis of the capabilities of JTIDS and the associated Link-16 message set, 2.) an exploration of the “messaging” capabilities inherent to JSAF, and 3.) behavioral relationships between JTIDS simulation and JSAF. We had to consider the types of scenarios and missions that might be supported and the volume of High Level Architecture (HLA) traffic that might be generated. The general view that developed was that platform entities would communicate within JSAF by sending transmission requests to the JTIDS simulation which, in turn, would provide a response if the target platform received the transmission. Approximately 40% of the Link-16 messages support destination addressing, so we agreed to provide a single address field in the transmission requests from JSAF to the JTIDS simulation. Link-16 also supports “broadcast” addressing, so we agreed to support a broadcast mode for future use. The team also agreed to initially limit the types of message transmissions to Command and Control, Mission Management, Mission Status, and Threat Warning messages as these were deemed more “mission critical.”

Both the JTIDS simulation and JSAF required enhancements to support this logical architecture (**Figure 4-3**). In addition, corresponding platform entities would have to exist in both JTIDS and JSAF so there was a need for a common reference mechanism for referencing platforms across the simulations.

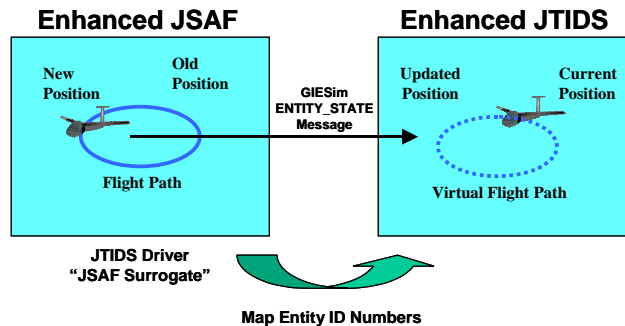

Figure 4-3. JSAF Platform Position Updates into JTIDS

4.3.3 Simulation Interfaces (Step #3)

In Step 3, the merger team faced several trade-offs in development of the simulation interface. Both JSAF and GIESim used HLA. However, JSAF used Run Time Infrastructure (RTI-s) whereas GIESim used the Defense Modeling and Simulation Office (DMSO) RTI. Given that JSAF has a huge software base, it seemed more cost-effective for GIESim to move to RTI-S. This was more challenging than initially expected. To support messaging between JSAF and JTIDS, the merger team agreed to use modified versions of the HLA interactions that were developed for inter-simulation communication by the GIESim team. However, JSAF was already using the Millennium Challenge 02 (MC02) HLA FOM and used HLA Objects. This required a merger of these FOMs into a new FOM that became known as MC02plus. JSAF also had to make some conversion between HLA Objects and HLA Interactions to support the merger interface. Both GIESim and JSAF needed to, and eventually did, confirm correct operation with the MC02plus FOM.

Figure 4.3 illustrates how JSAF sends platform position updates to the JTIDS simulation. Platform positions are critical in the JTIDS simulation for RF propagation calculations. A GIESim_ENTITY_STATE HLA interaction is used that contains the platform entity ID, LAT LON position, altitude, and heading. The entity ID is a unique number for each platform in the scenario that gets mapped to a simulation-specific internal platform reference. This interface mapping approach allows each simulation to retain its own internal platform references. The merger team agreed that the JTIDS simulation would generate a hash file for use in JSAF. Note that a JTIDS Driver simulation was built that served as a surrogate for JSAF. This simulation proved invaluable in early testing of the enhanced JTIDS simulation and helped to isolate problems that occurred in early interoperability testing.

Figure 4-4 illustrates a message transmission request from JSAF to JTIDS. JSAF sends a GIESIM_MSG_SEND HLA interaction with the sending and destination platform entity IDs, a JSAF message ID number and size, and a Net Type Number. See next section for details. If JTIDS can find an appropriate network, it will send the message. If the destination platform receives the message, JTIDS will send JSAF a GIESIM_MSG_RCVD HLA interaction with the destination entity ID, JSAF message ID, and accumulated latency.

Tactical communications may fail due to interference, distance, etc. Therefore, the merger team needed to determine how to handle this. **Figure 4-5** shows handling of successful communications and communications failure. The top part of the figure shows successful communications. JSAF builds a message that is intended for a specific platform. Rather than sending the actual message to JTIDS, JSAF sends the message ID and its size to JTIDS with the appropriate addressing, etc. When the target platform receives the message in the JTIDS simulation, the simulation then sends a response to JSAF with the platform entity ID and JSAF message ID. JSAF then processes the message and takes some action.

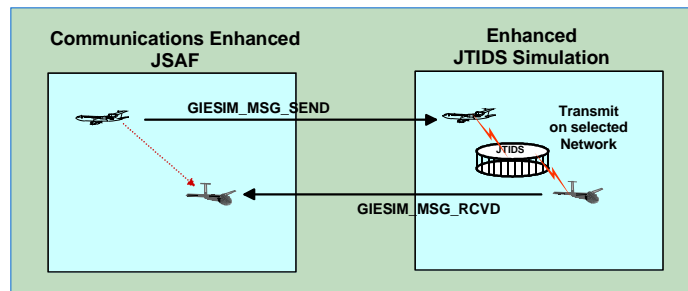

Figure 4-4. Message Transmission Request and Response

When a transmission is lost, JTIDS does not send a response to JSAF. This is how communications work in the physical world. JSAF either times out or makes several retransmission attempts¹.

¹ J. Reaper, et.al.^[1], describes JSAF message handling in the companion to this paper.

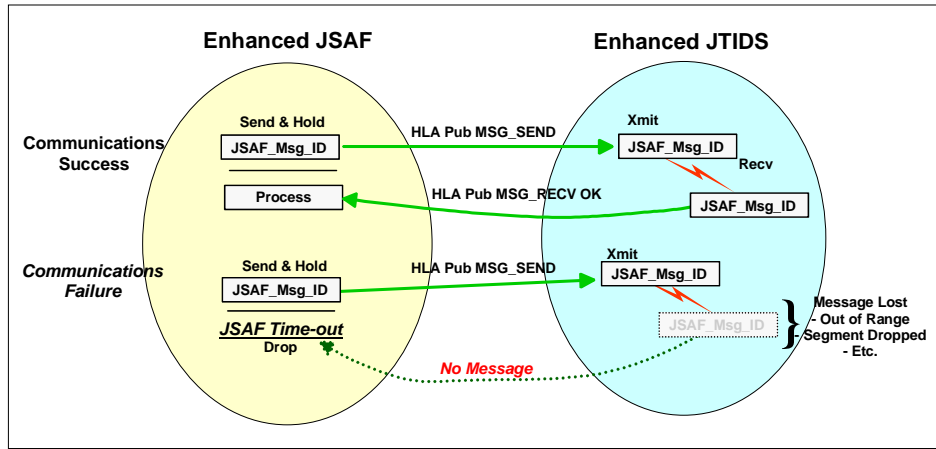

Figure 4-5. Communications Message Handling

4.3.4 JTIDS Simulation Model Enhancements

The GIESim JTIDS simulation was modified to support operation with JSAF, which involved position updates and transmission requests from JSAF and message-received responses to JSAF^{[4][5]}.

Position Updates: The original JTIDS simulation dynamically updated platform positions from its own scenario file. To support platform updates from JSAF, models were added to take platform position updates externally over HLA. The GIESIM_ENTITY_STATE HLA interaction was used to supply the update data, and **Table 4-1** shows the parameters for this HLA interaction within the JTIDS simulation. JSAF filled in the values for Entity ID, platform heading, platform position in the form of LAT LON data, and platform altitude. The other parameters were not used.

GIESIM_ENTITY_STATE HLA Interaction

ENTITY_TYPE_DETAIL	
1	ENTITY_TYPE CHAR
1	DOMAINX CHAR
1	COUNTRY_CODE INDEX
1	CATEGORY CHAR
1	SUBCATEGORY CHAR
	ENTITY_ID_DETAIL INDEX
HEADING_DETAIL REAL	
WORLD_LOCATION_DATA	
1	LAT REAL
1	LON REAL
1	ALT REAL
	SPECIAL_EFFECTS_DATA INTEGER

Table 4-1. Communications Message Handling

Entity IDs: JSAF and the JTIDS simulations each use their own representation of platforms and platform IDs. Rather than make substantive changes to either simulation, the merger team agreed to use a common set of platform reference numbers or Entity IDs when exchanging HLA interactions. Each simulation would map an Entity ID to or from its own reference to a particular platform. The team agreed to use the unique Entity ID numbers produced by the JTIDS simulation. Hashing the platform names used in the JTIDS scenario file generated these numbers.

Transmission Request & Response: The area of greatest change in the merger was message handling in both simulations. The JTIDS simulation was designed to internally send messages to gather performance data on the quality of network designs. For the GIESim project, modifications had been made to the JTIDS simulation to allow certain messages to pass through the simulation. To support JSAF, however, the JTIDS simulation messaging capabilities had to be generalized and significantly expanded.

JTIDS uses many networks between groups of platforms. Each network serves a specific purpose and satisfies specific communications requirements. While there are many networks, there is usually a small collection of network *types*, e.g., mission management networks vs. threat warning networks. The merger team agreed to assign a net type number to each category of networks. The enhanced JTIDS simulation outputs a NETMAPFILE file such that JSAF can reference the type of network needed for a message transmission. This approach attains a certain amount of useful decoupling between JSAF and JTIDS.

Figure 4-6 illustrates the transmission message handling in the enhanced JTIDS simulation. When JTIDS receives a GIESIM_MSG_SEND interaction, it first attempts to map the entity IDs for the source and destination platforms to internal values. Transmission requests drop if IDs are bad. If entity mapping is successful, then JTIDS takes the NET Type number and looks up the associated text description. JTIDS then attempts to find a net based on the source and destination platform and the network description. If an appropriate net is found, then JTIDS puts the JSAF message ID and incoming latency into the JTIDS message payload. If the JSAF message size fits into the capacity of the selected network, it is sent as a single message. If the JSAF message is too big for the network, then JTIDS performs message segmentation and sends multiple segments. At the receiving end, segments are reassembled. When a whole message has been received successfully, JTIDS builds a GIESIM_MSG_RCVD response message that includes the entity ID of the destination platform, accumulated latency and JSAF message ID.

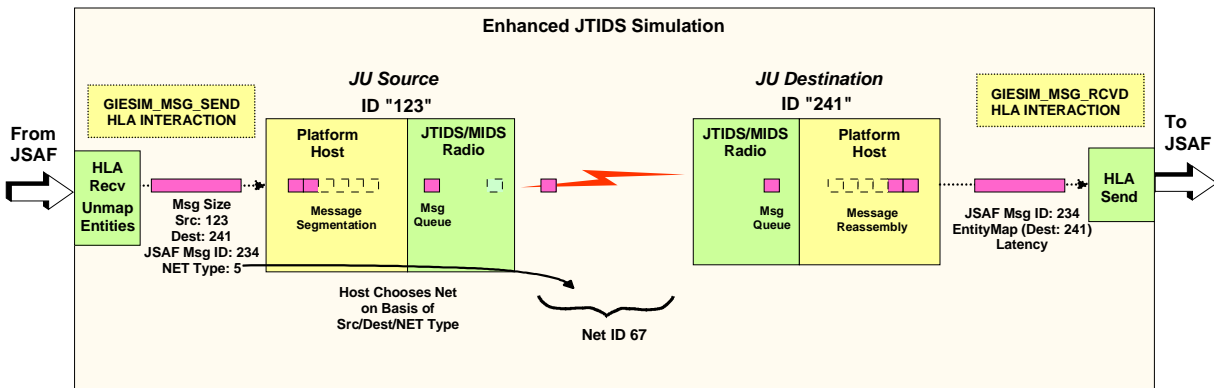

Figure 4-6. Enhanced JTIDS Message Handling

Several models and processes within the JTIDS simulation had to be modified and enhanced to support simulation interfacing with JSAF. One of the most significant changes was the addition of the JSAF “payload” to the internal data structures in the simulation. This change percolated through many parts of the JTIDS simulation.

The move from the DMSO RTI to RTI-S in the JTIDS simulation turned out to be challenging as stated above. The JTIDS simulation was built and maintained with the General Simulation System (GSS[®])^{[6][7]}. GSS is a high performance, rapid development language and environment developed by PSI for building models and running simulations and planning tools. Due to library name changes in RTI-S, a few minor, though tricky, modifications were needed in GSS for the JTIDS simulation to run with RTI-S. Also, while RTI-S seems more robust than the DMSO RTI, it performs a check-sum on the FED files, which requires all FED files to match. The DMSO RTI allowed each simulation to use subsets of a larger FOM.

As mentioned earlier, PSI built a modified version of JTIDS to serve as a Driver surrogate for JSAF. This Driver simulation can send platform position updates automatically or manually, and can manually formulate message transmission requests. The Driver was invaluable for early testing of the enhanced JTIDS simulation for JSAF, and for exploring early interoperability problems with JSAF. The Driver also allowed testing and refinement of scenarios and networks.

4.3.5 Scenario Design and Mission Goals (Step #4)

Scenario development is one of the more challenging aspects for any distributed simulation environment. **Figure 4-7** illustrates the layers of scenario development that the merger team considered while building the scenario for the initial GIESim-JSAF interoperability testing and demonstration.

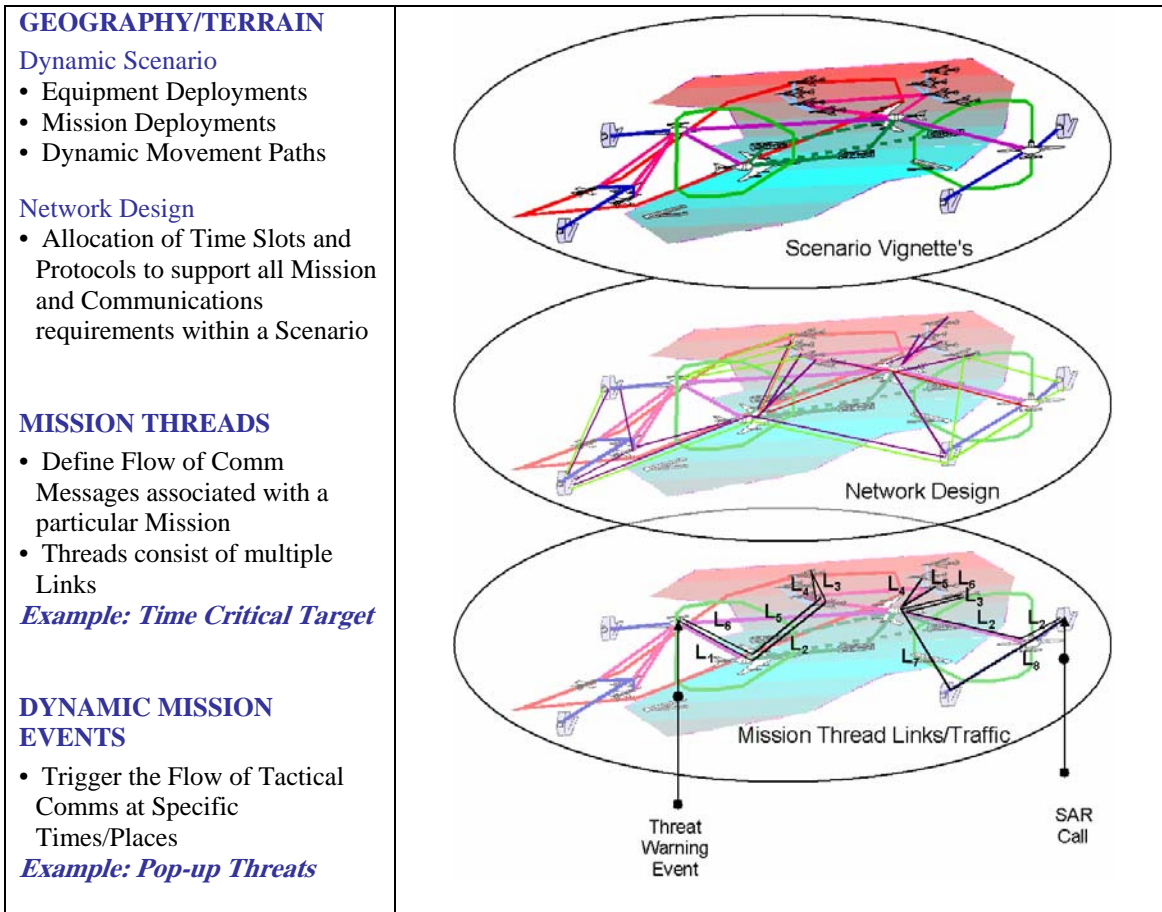

Figure 4-7. Hierarchical Layers in Scenario Development

The dynamic operational scenario proved to be more of a challenge because the merger team wanted a scenario that was simple but operationally relevant, had visual impact, and could run fast enough for an effective demonstration. Therefore, the team agreed to use the Korean theater for the area of operation since this was currently used by GIESim and was readily available to the JSB-RD team for JSAF.

The scenario that became accepted involved a Special Operations Force (SOF) on the ground that observes a Time Sensitive Target (TST). A tactical F-15 STRIKER² aircraft receives a target message from the SOF and follows terrain during ingress to the target. Later on, the SOF detects a mobile SAM site and attempts to warn the incoming STRIKER. However, the SOF is now separated from the STRIKER by a mountain ridge. The overall scenario became known as the “Wow” scenario. A screenshot of this scenario is shown in **Figure 4-8** at the point where the F-15 is following terrain through a valley towards the target. There are three variations to the scenario that are intended to demonstrate the importance of tactical communications.

Scenario 1 – JSAF Only: The SOF “notifies” the STRIKER who evades the SAM. The STRIKER survives.

Lesson: The simulation is unrealistic, and worse, it erroneously predicts *the STRIKER gets away*. This is not acceptable for realistic simulation planning – *people can get killed*.

Scenario 2 - JSAF w/ Comms but no Relay: The SOF uses JTIDS to send a threat warning to the STRIKER but the mountain range blocks direct radio contact. *The STRIKER gets hit*.

Lesson: We need to account for distance, terrain, and network design in realistic mission planning!

² The term STRIKER is used to refer to tactical aircraft with the mission assignment of striking a target.

Scenario 3 - JSAF w/Comms and Relay: Based on the results of the prior run, we turn on a JTIDS relay on a UAV. Now the STRIKER gets the relayed threat warning and evades!! *The STRIKER gets away.*
Lesson: Communications modeling and advanced planning in support of operations is critically important!

Because the simulation detected communications failure, required adjustments could be made to the deployment and network design to ensure success of the mission.

The flight path of the F-15 STRIKER aircraft is shown in **Figure 4-8**. Crosses along the path indicate waypoints. The SOF is in the upper right near the TCT (red square) and pop-up threats (crosses). The UAV in the upper left follows a flight path that keeps it near the area of operation. The F-15 has entered the valley on its way to the target. The heavy dotted line indicates that direct communications with the SOF are broken due to the mountain range. The other heavy lines indicate good network connection between the UAV and the F-15 and to the SOF. Additional details on the design of the “Wow” scenario and its associated JTIDS networks are discussed in the next section.

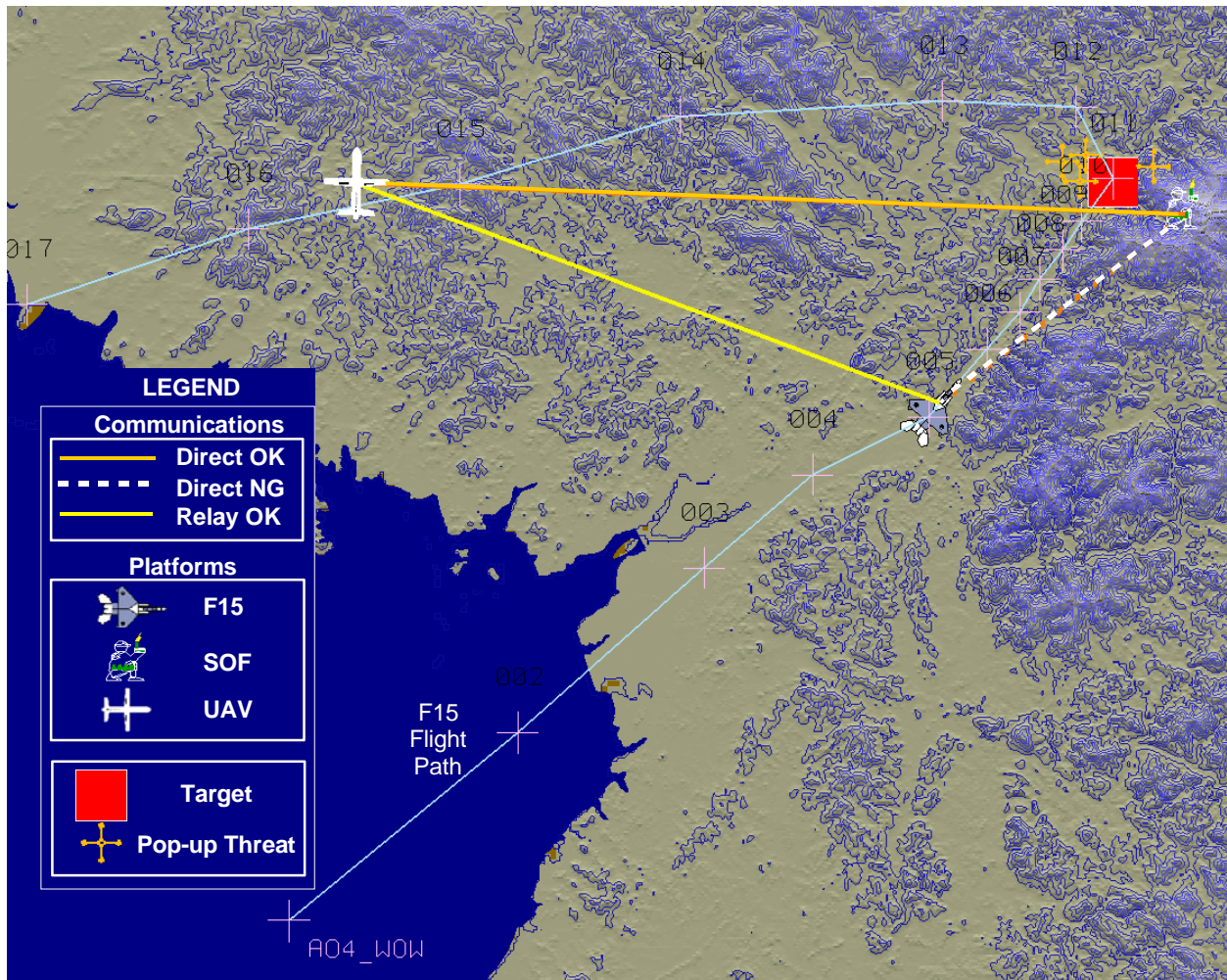

Figure 4-8. SOF, STRIKER, UAV Relay, Time Sensitive Target, and Threats in the “Wow” Scenario

4.3.6 Planning and Network Design (Step #5)

The “Wow” scenario was designed using the Link-16 Planning Tool. This planning tool is part of a Link-16 Network Management System (NMS)^[8] designed and built by PSI for the Air Force. It is important to note that the PSI Link-16 NMS illustrated in **Figure 4-9** was, and continues to be, critically important to the success of the GIESim/JSB-RD software merger. The Link-16 Planning Tool was used to define the initial scenario and all Link-

16 Networks used in the merger; the enhanced version of the Link-16/JTIDS Simulation is the tactical communications component that we added to JSAF.

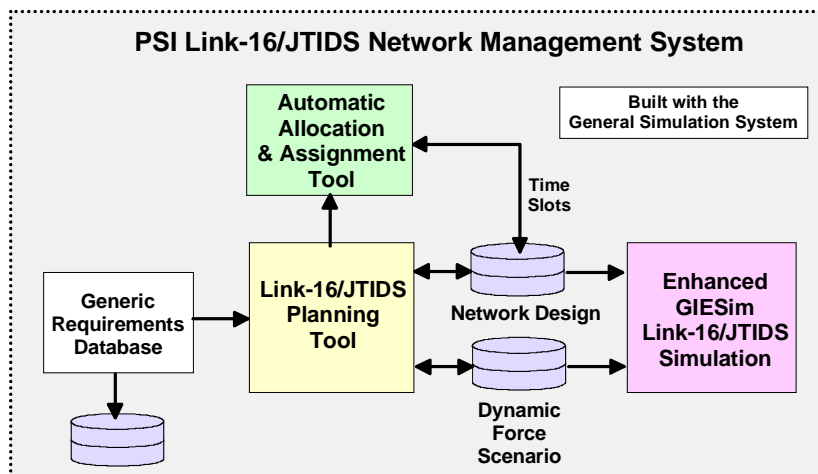

Figure 4-9. PSI Link-16 Network Management System

The screenshot of the “Wow” scenario in Figure 4-8 was taken from the Link-16 Planning Tool. We first used the tool to determine the best location for the “Wow” scenario, then built a flight path for the F-15 that started high and then dropped to follow terrain through the valley leading to the target. We also positioned the UAV relay such that RF links were always available to the SOF and to the F-15. We then “captured” the network requirements for the “Wow” scenario that had been agreed to by the team. Three networks were defined, as shown in **Table 4-2**.

Net Purpose/Label	Net Type #	Link-16 Msg	Source	Destination	Access Mode	Response Time
Threat Warning	14	J15.0	SOF	F-15	Dedicated	1 Sec
Mission Control	15	J12.7	SOF	F-15	Dedicated	2 Sec
Engagement Status	16	J12.6	F-15	SOF	Contention	2 Sec

Table 4-2. “Wow” Scenario JTIDS Networks

JTIDS/Link-16 is the preeminent tactical waveform today, and is the most complex. JTIDS uses a mix of Time Domain Multiple Access (TDMA), Frequency Domain Multiple Access (FDMA), and Collision Detection Multiple Access (CDMA), and therefore requires that networks be *custom designed* to support all platform communications requirements. The term “design” refers to *allocation* and *assignment* of appropriate time slots, which has been a complex and time consuming process. The PSI Link-16 NMS automates the time slot allocation process. As shown in Figure 4-9, the Link-16 NMS has a Generic Requirements Database manager that is used to define “generic” requirements. The Planning Tool is used to build dynamic scenarios, to capture and refine network requirements, and can launch the Automatic Allocation and Assignment Tool, which automates time slot allocation in minutes. The completed scenario and network design are fed into the JTIDS. Link-16 Simulation to assess network design performance by passing message traffic between Link-16 equipped platforms as they move. The data for the “Wow” scenario was exported and then imported into JSAF.

Key characteristics of the PSI Link-16 Network Management System include:

- Rapid generation of complex, dynamic scenarios against terrain.
- Accurate and fast radio propagation models that use 3-D terrain data, the effects of transmitter power and antenna types, and that account for mutual interference and noise sources.
- Ability to visualize

- 2-D and 3-D terrain and terrain contours plus political boundaries.
 - Movement paths and platform motion along the paths.
 - Dynamic RF link connectivity between platforms.
 - Network requirements (including relays) that are either satisfied or unsatisfied.
- Ability to capture and refine network requirements and automation of time slot allocations.
 - Ability to simulate message traffic by events in dynamic scenarios.
 - Ability to dynamically assess network performance.
 - Supports rapid iterative design and refinement of mission scenarios and network designs.
 - Enhanced interface to JSAF for external position updates, handling of network transmission requests, and notification of received messages.

PSI has used the Link-16 NMS to design scenarios and networks of much greater complexity.

4.3.7 Component Integration (Step #6)

Figure 4-10 illustrates the integration of the JSAF and JTIDS simulation. The common scenario contains both the force deployments and their associated movement paths. The initial version of this common scenario was developed in the Link-16 Planning Tool. Each simulation environment then codifies the scenario for its force deployment. Movement paths are imported into JSAF. Based on the force deployment, the JTIDS simulation generates an Entity Map file that JSAF uses to encode platform references to JTIDS. JTIDS reads in the network file that contains requirements and actual network designs, i.e., time slot allocations, and generates a Net Types file that JSAF uses to specify a network in a transmission request. Both simulations use the MC02plus FOM. Once both simulations are started, JSAF sends position updates to JTIDS, and makes message transmission requests. Both simulations use the MC02plus FOM. Once both simulations are started, JSAF sends position updates to JTIDS, and makes message transmission requests.

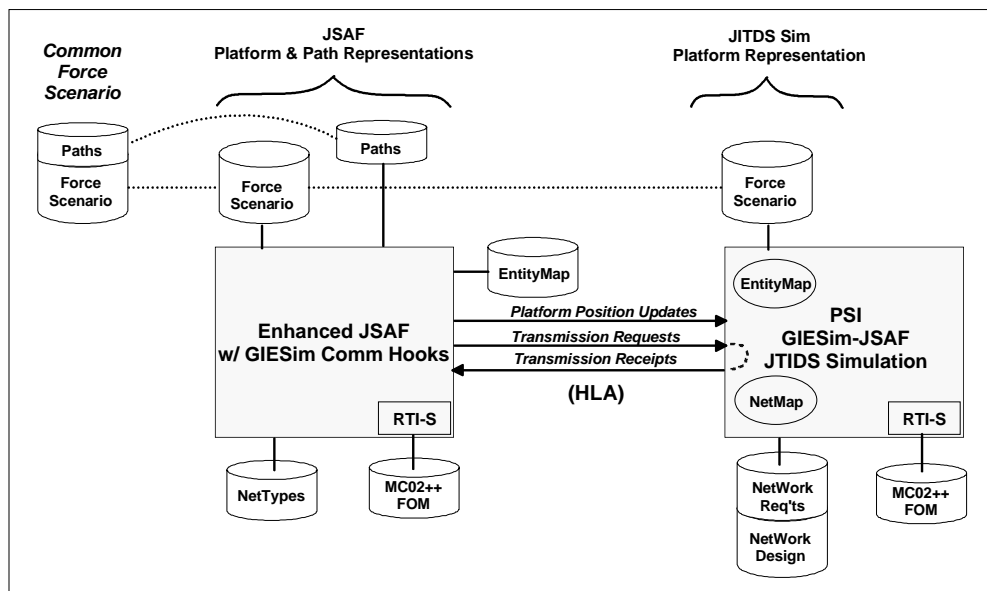

Figure 4-10. Integration of JSAF and JTIDS Simulations

We faced several operational challenges in getting the two systems to integrate, which took longer than expected. Challenges fell into two main categories: physical interoperability and scenario interoperability.

Initially, the move to RTI-S caused some delay in the JTIDS simulation, which was discussed earlier. Face-to-face lab time was limited because the merger team was split over three distant geographical locations. One remote site did not have Linux or JSAF; the nature of RTI-S, firewalls, and security concerns ruled out testing over the Internet.

The ability to visualize scenarios in both JSAF and the JTIDS simulation helped immensely. Also, the ability to manually construct and examine messages in both simulations proved to be invaluable. For the JTIDS simulation, manual message construction and examination were a legacy of prior GIESim work. Background diagnostic messages also facilitated rapid resolution of minor interoperability issues.

Scenario interoperability refers to the ability to achieve the simulation results expected. Recall that the original “Wow” scenario was designed with the Link-16 NMS planning tool. Scenario data was imported into JSAF where minor changes occurred, such as the position of the SOF. Also, in a desire to shorten the demonstration run time, the flight path of the F-15 was shortened. In radio communications at 1 GHz (the operating frequency of JTIDS) minor position changes, particularly of ground radios in heavy terrain, can impact connectivity. These minor differences were quickly corrected. Interoperability success was finally achieved, and the team is now looking to apply the merged software to larger scenarios.

4.4 GIESim Phase III Operation Scenarios

The dynamic operational scenario proved to be more of a challenge as the merger team required a scenario that was simple but operationally relevant, had visual impact, and could run fast enough for an effective demonstration. Therefore, the team agreed to use the Korean theater for the area of operation since this was currently used by GIESim and was readily available to the JSB-RD team for JSAF.

The scenario that became accepted involved a Special Operations Force (SOF) on the ground that observes a Time Sensitive Target (TST). A tactical F-15 STRIKER³ aircraft receives a target message from the SOF and follows terrain during ingress to the target. Later on, the SOF detects a mobile SAM site and attempts to warn the incoming STRIKER. However, the SOF is now separated from the STRIKER by a mountain ridge. The overall scenario became known as the “Wow” scenario. A screenshot of this scenario is shown in **Figure 4-11** at the point where the F-15 is following terrain through a valley towards the target. There are three variations to the scenario that are intended to demonstrate the importance of tactical communications.

Scenario 1 – JSAF Only: The SOF “notifies” the STRIKER who evades the SAM. The STRIKER survives.

Lesson: The simulation is unrealistic, and worse, it erroneously predicts *the STRIKER gets away*.

This is not acceptable for realistic simulation planning – *people can get killed*.

Scenario 2 - JSAF w/ Comms but no Relay: The SOF uses JTIDS to send a threat warning to the STRIKER but the mountain range blocks direct radio contact. *The STRIKER gets hit*.

Lesson: There is a need to account for distance, terrain and network design in realistic mission planning!

Scenario 3 - JSAF w/ Comms and Relay: Based on the results of the prior run, we turn on a JTIDS relay on a UAV. The results, the STRIKER gets the relayed threat warning and evades! *The STRIKER gets away*.

Lesson: Communications modeling and advanced planning in support of operations is critically important!

Because the simulation detected communications failure, required adjustments can be made to the deployment and network design to ensure success of the mission.

The flight path of the F-15 STRIKER aircraft is shown in Figure 4-12. Crosses along the path indicate waypoints. The SOF is in the upper right near the TCT (square) and pop-up threats (crosses). The UAV in the upper left follows a flight path that keeps it near the area of operation. In Figure 4-12, the F-15 has entered the valley on its way to the target. The heavy dotted line indicates that direct communications with the SOF are broken due to the mountain range. The other heavy lines indicate good network connection between the UAV and the F-15 and to the SOF. Additional details on the design of the “Wow” scenario and its associated JTIDS networks are discussed in the next section.

³ The term STRIKER is used to refer to tactical aircraft with the mission assignment of striking a target.

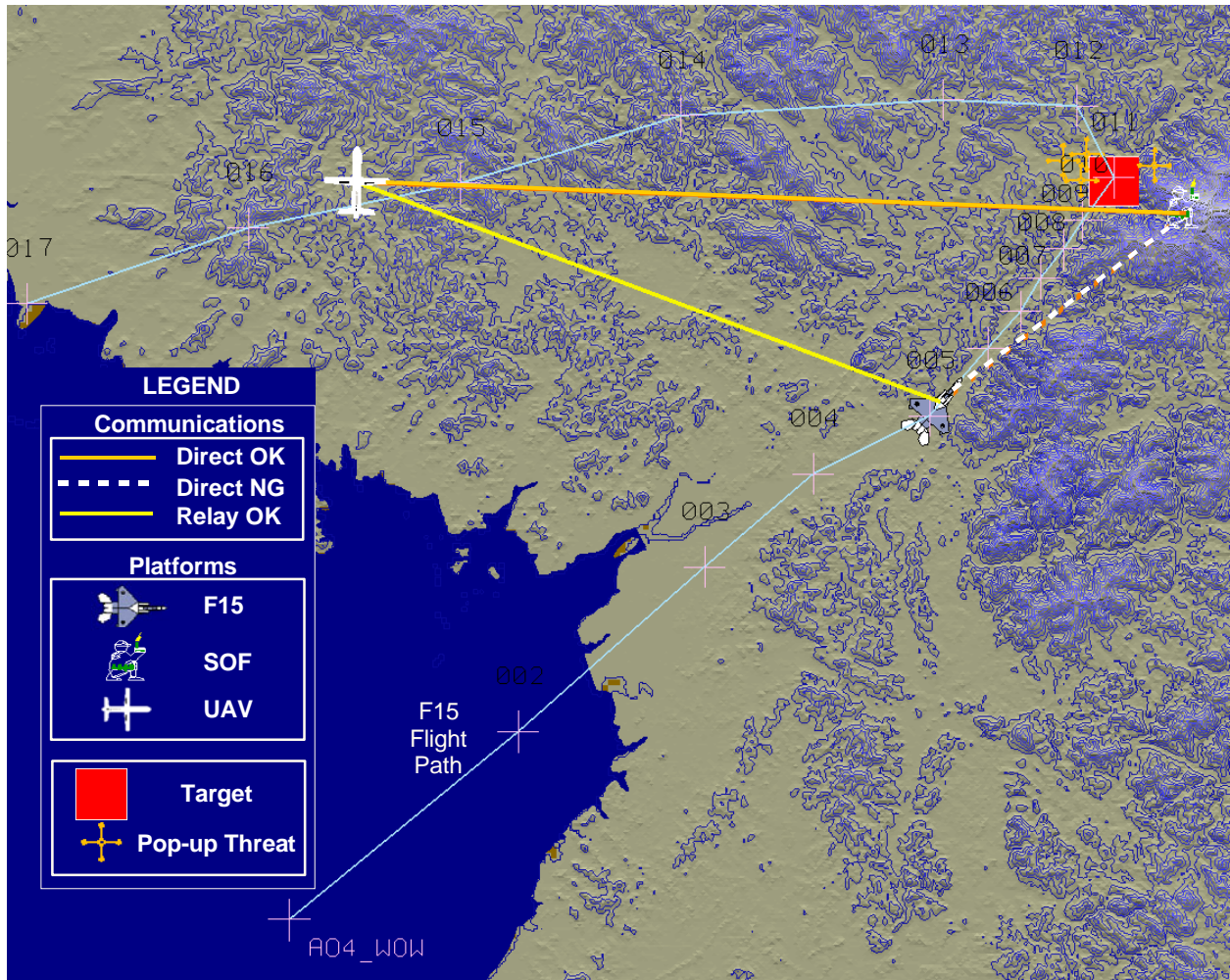

Figure 4-11. SOF, STRIKER, UAV Relay, Time Sensitive Target and Threats in the “Wow” Scenario

5.0 LESSONS LEARNED

This section summarizes the lessons learned during this effort. These are organized into the following topics:

- Subject Matter Experts are critical to the success of the program from communication needs to communication simulations development to execution of the scenario.
- Defining and Developing realistic operational tactical communication scenarios should not be underestimated. This is a difficult area; however it is a vital area rich in system payoff.
- War Gaming Software application integration is complicated requiring expert, experienced, and knowledgeable system developers to accomplish the planned goals and objectives.
- Repeatability: It is important that the Subject Matter Experts review and refine the demonstration scenario(s) for realism and future/advanced communication needs.
- JSAF Software Complexity.

5.1 Criticality of Subject Matter Experts

Subject Matter Experts were critical to the success of the GIESim program from communication needs to communication simulations development to execution of the scenario(s). Retired, experienced Air Force mission experts within the intelligence operations area, provided real-world scenarios with realistic communications equipment staging along the legs of the operational steps of the mission simulations.

5.2 Communication Scenarios

Scenario development has been and continues to be a very demanding process. Also, the need for mission operational subject area experts is critical and increasing. Knowing that these experts are fewer in number, a requirement exists for the capture and development of scenario databases to support the next generation of M&S. Future systems depend on the M&S technology step to push the envelope of technicality.

5.3 JSAF Software Complexity

The JSAF software is very large and complex. It consists of more than 1000 individual software object libraries. There is a complex web of dependencies that connects these libraries to one another. The JSAF software is written in ANSI C, and has a multifaceted object-based architecture that simulates inheritance and aggregation relationships among libraries. Extensive configuration script and reader (i.e., data) files further add to this complexity. This complexity makes the JSAF software very difficult to modify. Adding a new type of object attributes – for example, a ground vehicle, for example (i.e., a taxi) that could require that additions be made to approximately a dozen different source code, configuration script, and reader files.

5.4 GIESim-JSAF Software Application Integration

Without the joint GIESim and JSAF Team knowledge within their respective application areas, the software integration and modification process would have been much more difficult and costly. The complexity of both software packages (GIESim and JSAF) would have made this integration time consuming and a low payoff venture. AFRL, PSI, SAIC, NG, and SRC are to be commended for their respective management and technical expertise and the achievement of the GIESim-JSAF merger.

6.0 PROPOSED FUTURE WORK

The following paragraphs provide proposed new work areas for consideration. The first GIESim/JSB-RD Additional Effort provides technology that would enhance the current GIESim/JSAF merger software, whereas the second and third provides areas that could be potentially high payoffs. However, these two areas will need more investigation to identify what could be performed by future GIESim efforts.

6.1 GIESim/JSB-RD Additional Effort

The GIESim/JSB-RD merger of tactical JTIDS communications with JSAF was, and is, a success. Additional effort is required to take this accomplishment from a successful proof-of-concept demonstration to a fully scaled-up, robust capability for use in large war gaming activities. Larger scenarios must be explored with more complex tactical messaging. Cross-simulation scenario design needs to be made easier and mission goals must feed network requirements. Furthermore, scalability must be explored to determine the computational architecture that may be required for high message traffic in large scenarios. While this may be complex, the merger team has laid the groundwork and established a foundation to make this happen rapidly at low cost.

The merger team has taken a large step that provides a forum for mission, communications, and operations planners to work together in a distributed simulation environment. Network Centric Operations requires C3, and the merger has added Communications to Command and Control to realize the needed C3. The merger has also opened the door to the integration of other tactical communications to JSAF. Training and gaming can now begin to take on communications challenges in a realistic way. The combined merger team has the experience to make this happen.

6.2 Airborne Network

Additionally, the Airborne Network system must be explored as a development and integration point. GIESim simulated today's aircraft information exchange via data links, which communicate specific information to specific radios in specified message formats. In contrast, network connectivity provides global access to information and the ability to pull or push information to all others connected to the network. If two aircraft are connected to the network, they will be able to exchange information, even if they do not have a direct connection. The challenge and requirements for the airborne network is to make what works in a ground-(based) environment work in an airborne-dynamic environment. Wires and fiber optic cables provide the "backbone" for ground-based networks; space-based optical lasers and aircraft carrying advanced communications systems will form the backbone of the airborne network. Large aircraft and unmanned air vehicles, equipped with greater communications capability, bandwidth, and connections to space and ground, could provide the backbone-in-the-sky. This type of Modeling and Simulation communication environment should be the next consideration within GIESim/JSAF advancement and future development.

6.3 Optical & RF Combined Link Experiment (ORCLE)

The Defense Advanced Research Projects Agency's (DARPA) has sponsored a BAA to investigate, prototype, and demonstrate an Air-to-Air-to-Surface hybrid [combined and simultaneous Free Space Optical (FSO) and Radio Frequency (RF)] link and networking concept that has a compact form factor, high availability, and high average data rate under all weather conditions. The principal focus of the BAA ORCLE is the Range and Flight Demonstration Systems Integration and the Technology Maturation that includes:

- Optical Channel Obscuration Mitigation (i.e., transmission through clouds)
- Common/Combined FSO/RF aperture
- Compact Optical Beam Steering
- Hybrid (FSO & RF) Router Technology

7.0 REFERENCES

1. J. H. Reaper, D. A. Trevisani, K. D. Trott, "Incorporating realistic command, control, and communications (C3) effects in military mission level simulation," *Enabling Technologies for Simulation Science IX*, Proceeding of SPIE Vol. 5805, 2005.
2. "Understanding Link 16" – A Guidebook for USAF Operators, 2nd Edition for the USAF Dec 2002, Langley AFB, Hampton VA 23665, and Northrop Grumman Information Technology, San Diego CA 92121, Document number 135-02-004.
3. "Technical Considerations for the GIESim-JSAF Merger," Prepared for AFRL IFGA by Prediction Systems, Inc. 2004.
4. "Enhanced Simulation Interfacing," Prepared for AFRL IFGA by Prediction Systems, Inc., 2004 for GIESim-JSAF Merger.
5. "M&S Design, Development and Testing," Prepared for AFRL IFGA by Prediction Systems, Inc., 2004 for GIESim-JSAF Merger.
6. "The General Simulation System Users Manual," Release 10.3, Prediction Systems, Inc., October 2004.
7. "The Run-Time Graphics (RTG) Users Manual," Release 10.4.0, Prediction Systems, Inc., September 2004.
8. "Link-16 Network Management System User Guide," prepared for AFRL/IFGD by Prediction Systems, Inc., May 31, 2004.

8.0 ACRONYMS

AF	Air Force
AFRL	Air Force Research Laboratory
AGI	Analytical Graphics Inc.
BAA	Broad Area Announcement
CAST	Communications Analysis and Simulation Toolkit
CDMA	Collision Detection Multiple Access
CONOP	Concept of Operations
CONUS	Continental US
DARPA	Defense Advanced Research Projects Agency
DMSO	Defense Modeling and Simulation Office
DoD	Department of Defense
FDMA	Frequency Detection Multiple Access
FOM	Federation Object Model
FSO	Free Space Optical
FTI	Frontier Technology, Inc.
GIE	Global Information Enterprise
GIESIM	Global Information Enterprise Modeling & Simulation
GIESIM-JSAF	Global Information Enterprise-Joint Semi-Automated Forces
GSS	General Simulation System
HLA	High Level Architecture
IFGA	Distributed Information Systems Branch
JBI	Joint Battlespace Infosphere
JBISIM	Joint Battlespace Infosphere Simulation
JSAF	Joint Semi-Automated Forces
JTIDS	Joint Tactical Information Distribution System
M&S	Modeling & Simulation
MOE	Measures of Effectiveness
MOM	Measures of Merit
MOP	Measures of Performance
NAM	Network Animator
NMS	Network Management System
ODK	OPNET Development Kit
ORCLE	Optical & RF Combined Link Experiment
OT&E	Operational Test and Evaluation
PSI	Prediction Systems, Inc.
RF	Radio Frequency
RTI	Run Time Infrastructure
RTI-S	Run Time Infrastructure-s (partial implementation)
SAIC	Science Applications International Corporation
SAM	surface-to-air missile
SATCOM	satellite communications
SOF	Special Operations Force
SRC	Syracuse Research Corporation
STK	Satellite Toolkit
TDMA	Time Detection Multiple Access
TEM	Technical Exchange Meeting
TST	Time Sensitive Target
UAV	Unmanned Aerial Vehicle