

**120 °C Cure, Durable, Corrosion Protection Powder
Coatings for Temperature Sensitive Substrates**

**SERDP PP-1268
General Electric Global Research**

Dr. Glen Merfeld

January 28th, 2005

Rev. 03

Report Documentation Page

Form Approved
OMB No. 0704-0188

Public reporting burden for the collection of information is estimated to average 1 hour per response, including the time for reviewing instructions, searching existing data sources, gathering and maintaining the data needed, and completing and reviewing the collection of information. Send comments regarding this burden estimate or any other aspect of this collection of information, including suggestions for reducing this burden, to Washington Headquarters Services, Directorate for Information Operations and Reports, 1215 Jefferson Davis Highway, Suite 1204, Arlington VA 22202-4302. Respondents should be aware that notwithstanding any other provision of law, no person shall be subject to a penalty for failing to comply with a collection of information if it does not display a currently valid OMB control number.

1. REPORT DATE 28 JAN 2005		2. REPORT TYPE Final		3. DATES COVERED -	
4. TITLE AND SUBTITLE 120 °C Cure, Durable, Corrosion Protection Powder Coatings for Temperature Sensitive Substrates				5a. CONTRACT NUMBER	
				5b. GRANT NUMBER	
				5c. PROGRAM ELEMENT NUMBER	
6. AUTHOR(S) Dr. Glen Merfeld, Steve Mordhorst, Irene Dris, Rainer Koeniger, Chris Molaison, Ron Singh Warner				5d. PROJECT NUMBER PP-1268	
				5e. TASK NUMBER	
				5f. WORK UNIT NUMBER	
7. PERFORMING ORGANIZATION NAME(S) AND ADDRESS(ES) General Electric Global Research One Research Circle Niskayuna, NY 12309				8. PERFORMING ORGANIZATION REPORT NUMBER	
9. SPONSORING/MONITORING AGENCY NAME(S) AND ADDRESS(ES) Strategic Environmental Research & Development Program 901 N Stuart Street, Suite 303 Arlington, VA 22203				10. SPONSOR/MONITOR'S ACRONYM(S) SERDP	
				11. SPONSOR/MONITOR'S REPORT NUMBER(S)	
12. DISTRIBUTION/AVAILABILITY STATEMENT Approved for public release, distribution unlimited					
13. SUPPLEMENTARY NOTES The original document contains color images.					
14. ABSTRACT					
15. SUBJECT TERMS					
16. SECURITY CLASSIFICATION OF:			17. LIMITATION OF ABSTRACT UU	18. NUMBER OF PAGES 107	19a. NAME OF RESPONSIBLE PERSON
a. REPORT unclassified	b. ABSTRACT unclassified	c. THIS PAGE unclassified			

Table of Contents

Research Participants and Co-Authors	3
List of Figures	4
List of Tables	6
Acronyms	8
Acknowledgements	9
Executive Summary	10
Objective	13
Project Background.....	13
Chapter 1: Performance Evaluation of Commercial Low Temperature Curing Powder Coats for Durable, Corrosion Resistant Applications.....	14
Chapter 2: Development of Low Temperature Curing, 120 °C, Durable, Corrosion Protection Powder Coatings for Temperature Sensitive Substrates	25
Chapter 3: Acid/Epoxy Reaction Catalyst Screening for Low Temperature (120 °C) Powder Coatings	39
Chapter 4: Advancements Toward Low Temperature Curing, 120 °C – 30 min, Powder Coatings for Temperature Sensitive Substrates	56
Chapter 5: Screening Corrosion Inhibitors in Low Temperature Curing, 120 °C – 30 min, Powder Coatings for Temperature Sensitive Substrates.....	70
Chapter 6: Formulation Optimization of a Low Temperature Curing,(120 °C – 30 min), Powder Coating for Temperature Sensitive Substrates	79
Chapter 7: Qualification and Field Repair Testing of a Low Temperature Curing, 120 °C – 30 min, Powder Coating	86
Chapter 8: Advancements Toward Aircraft Applications of Low Temperature Curing, 120 °C – 30 min, Powder Coatings.....	98
Conclusions.....	105
Appendix.....	106

Research Participants and Co-Authors

**GE Global Research
One Research Circle
Niskayuna, NY 12309**

Glen Merfeld (PI), Steve Mordhorst, Irene Dris,
Rainer Koeniger, Chris Molaison, Ron Singh Warner

**Crosslink Powder Coatings, Inc.
5182 126th Avenue North
Clearwater, FL 33760
Ken Gray**

**Air Force Material Command
Logistics Environmental Office
2179 12th Street
Wright-Patterson AFB, OH 45433-7718
Deborah Meredith, Steve Finley, Jerry Mongelli**

**Air Force Research Laboratory
2179 12th Street
Wright-Patterson AFB, OH 45433-7718
Shawn Fontenot, Chris Joseph, Tom Naguy, Grant Parker, Mike Spicer**

**Naval Air Systems Command
Research and Engineering Group
BLDG 2188, 48066 Shaw Rd. Unit 5
Patuxent River, MD 20670-1908
Kevin Kovaleski, Greg Garrett**

**Honeywell-DOE
Federal Manufacturing and Technologies
2000 East 95th Street
PO Box 419159
Kansas City, MO 64141-6159
Mark Smith**

List of Figures

Figure 1.1 Project overview and application illustration.	15
Figure 1.2 Heat of reaction is plotted vs. time for commercial benchmarks at the target cure condition of 120 °C for 30 minutes. The PE/Primid and the urethane showed no heat of reaction at 120 °C.	20
Figure 1.3 Heat of reaction at 120 °C vs. total potential heat of reaction.....	20
Figure 1.4 Impact Strength and MEK double rubs as a function of cure condition.	22
Figure 1.5 Radar plot showing property tradeoffs for powder chemistries studied. Responses have been normalized from 0 to 1, with 1 corresponding to the best performance, and the specification target indicated.	23
Figure 2.1 Star plot showing property tradeoffs for selected powder coatings prepared at their manufacturer’s lowest recommended cure schedule. Responses have been normalized from 0 to 1, with 1 corresponding to the best possible performance. Specification targets are included for reference.....	29
Figure 2.2 Experimental design for resin screening study. Twenty-four powder coatings were developed and evaluated using commercial acid functional polyester resins..	31
Figure 2.3 Heat of reaction at 120 °C versus reaction time for resin screening formulations. Legends indicate corresponding formulation numbers provided in Table 2.4. Note formulations A-1 and A-4 show no heat of reaction.....	33
Figure 2.4 Direct impact (solid lines) and chemical resistance (dashed lines) versus catalyst loading in resin systems C (triangles) and D (squares) using zinc phosphate corrosion inhibitor.....	34
Figure 3.1 Overview of powder coating chemistries and typical temperature ranges for cure. The systems are ranked from left to right in order of increasing opportunity for low temperature cure.....	43
Figure 3.2 DSC measured reaction conversion versus time at 120 °C for selected resin/crosslinker formulations.....	44
Figure 3.3 Representative candidate acid-epoxy reaction catalysts. Four categories of compounds are considered with examples in each class. Arrows indicate catalysts down selected in this work for screening studies.....	46
Figure 3.4 DSC evaluated kinetic responses for catalyst screening studies performed at 120 °C for 30 min.	49
Figure 3.5 Glass transition as a function of heat-of-reaction.	49
Figure 3.6 Nth order reaction rate model predictions for selected catalyst at 5 mole percent in Albester 5160 as a function of temperature.	51
Figure 3.7 Gel time at 180 °C as a function accelerated aging at 48 °C for selected catalysts at 5 mole percent.	52
Figure 3.8 Yellowness index (YI) versus catalyst loading for samples subjected to over-bake of 30 min at 160°C. Catalyst legend provided in Figure 3.4.....	52
Figure 4.1 Experimental design to evaluate catalyst level, manufacturing method, and particle size.	60
Figure 4.2 Experimental design to evaluate resin type, flow additives and inorganics level.....	61
Figure 4.3 Coatings evaluating increased catalyst level, flow additive, UV absorber. ...	62

Figure 4.4 Increased catalyst level, flow additives, and UVA weathering results—60° gloss.	63
Figure 4.5 Increased catalyst level, flow additives, and UVA weathering results — ΔE	64
Figure 4.6 Experimental flow additive formulations	64
Figure 4.7 Experimental resin and catalyst part 1 formulation plan.....	65
Figure 4.8 Experimental resin and catalyst part 2 formulation plan.....	66
Figure 4.9 Experimental resin reformulation.....	67
Figure 5.1 Experimental layout to screen 7 corrosion inhibitors on 3 substrates. Letter codes and colors correspond to corrosion inhibitors indicated in Table 5.2.....	74
Figure 5.2 Salt fog performance vs. SO ₂ performance on chromated aluminum.	74
Figure 5.3 Salt fog vs. SO ₂ corrosion performance on untreated aluminum.	75
Figure 5.4 Salt fog vs. SO ₂ corrosion performance on CRS panel pre-treated with zinc phosphate.	75
Figure 6.1 Diagram of full factorial optimization experiment. Catalyst level and resin/crosslinker ratio are investigated at three levels each.	82
Figure 6.2 60° Gloss improvement shown with finer, 170-mesh screen.	84
Figure 7.1 Color change (ΔE) results for UVB testing	88
Figure 7.2 60° Gloss results for UVB testing.	89
Figure 7.3 Cleanability as a function of soil soak temperature with Turco 660	90
Figure 7.4 Application and stripping performance as a function of time	91
Figure 7.5 Coupon preparation diagram	93
Figure 7.6 Crosshatch Adhesion Rating Scale.....	94
Figure 7.7 Modified X-cut within parallel cuts.....	95
Figure 8.1 Blend plan I for GE Resin A.	101
Figure 8.2 Blend plan II for GE Resin B.	102
Figure 8.3 Blend plan for screening GE Resin.	103

List of Tables

Table 1.1 Commercial powders.	15
Table 1.2 Test substrates	16
Table 1.3 Performance specifications.	18
Table 1.4 DSC screening results for low temperature cure.....	19
Table 1.5 Screening evaluation of commercial benchmark materials.	21
Table 2.1 Target performance specifications for 120 °C – 30 min cure powder coating	26
Table 2.2 Commercial low temp cure powder coating performance	29
Table 2.3 Powder coating formulations used in resin screening experiments	31
Table 2.4 Resin screening summary	32
Table 2.5 Catalyst screening study.....	35
Table 3.1 Resins and crosslinkers	40
Table 3.2 Catalysts	41
Table 3.3 DSC Measurement statistics for replicate testing at 120°C – 30 min	42
Table 3.4 Commercial resin /crosslinker formulations.	44
Table 3.5 Rucote 921 formulations	47
Table 3.6 Crylcoat 7309 and Albester 5160 formulations	47
Table 3.7 Kinetic model parameters and reaction rates	50
Table 4.1 Target performance specifications for 120 °C – 30 min cure powder coating.	57
Table 4.2 Typical powder formulation for low temperature cure.	58
Table 4.3 Scorecard results for catalyst level, manufacturing method, and particle size.	61
Table 4.4 Results investigating resin type, flow additive type, and inorganics level.	62
Table 4.5 Increased catalyst level, flow additives, and UVA results.	63
Table 4.6 Experimental flow additive results.....	65
Table 4.7 Experimental resin and catalyst results part 1.....	66
Table 4.8 Experimental resin and catalyst results part 2.....	66
Table 4.9 Experimental resin reformulation	67
Table 5.1 Formulation components.....	71
Table 5.2 Eight corrosion inhibitors color-coded for experimental identification.....	72
Table 5.3 ASTM D1654 rating scale for corrosion undercutting from sample scribe.	73
Table 5.5 Physical performance of corrosion inhibitor formulations.	76
Table 5.6 Physical performance of corrosion inhibitor formulations.	76
Table 6.1 Target Performance Specifications for 120 °C–30 min Cure Powder Coating	80
Table 6.2 Powder coating components and center point formulation.....	80
Table 6.3 Performance scorecard.	83
Table 7.1 Screening performance specifications.....	86
Table 7.2 Qualification performance specifications	87
Table 7.3 QPL approved cleaners used in this work.....	89
Table 7.4 Formulation refinements to enhance cleanability and surface quality.....	90
Table 7.5 Scorecard of Table 7.4 formulation performance.	91
Table 7.6 Coating and patch systems used for field repair	92
Table 7.7 Patti adhesion results.....	94
Table 7.8 Initial crosshatch adhesion results.....	95
Table 7.9 Wet tape adhesion rating scale	95
Table 7.10 Post hydraulic immersion crosshatch adhesion results	96

Table 8.1 Screening specifications for aircraft applications.	98
Table 8.2 Powder coating components including GE resin.	99
Table 8.4 Blend Plan II physical properties.	103
Table 8.5 Blend Plan III physical properties.	104

Acronyms

SERDP-Strategic Environmental Research and Development Program
ESTCP-Environmental Security Technology Certification Program
AFMC-Air Force Material Command
AFRL-Air Force Research Laboratory
ASTM-American Society For Testing and Materials
BTMABr-Benzyltrimethylammonium Bromide
CC-Choline Chloride
CI-Corrosion Inhibitor
DoD-Department of Defense
DoE-Department of Energy
DOI-Distinctness of Image
DSC-Differential Scanning Calorimetry
GMA-Glycidyl Methacrylate
GEGR-General Electric Global Research
HAA-Hydroxyl Alkyl Amide
HALS-Hindered Amine Light Stabilizer
MEK-Methyl Ethyl Ketone
PCI-Powder Coating Industry
PE-Polyester
TGIC-Triglycidylisocyanurate

Acknowledgements

The authors thank Ken Gray at Crosslink Powder Coatings, Inc. (Clearwater, FL) for his expertise, partnership, and contributions to this program. We are grateful to 2D Lt. Shawn Fontenot, Chris Joseph, Tom Naguy, 2D Lt. Grant Parker, Mike Spicer of the AFRL (WPAFB, OH), and Steve Finley, Deborah Meredith, Jerry Mongelli of the AFMC (WPAFB, OH) for execution of field repair evaluations. We thank Greg Garrett and Kevin Kovaleski at NavAir (Patuxent River, MD) for their implementation and interpretation of SO₂, cyclic, and filiform corrosion. We thank Mark Smith at Honeywell DoE (Kansas City, MO) for leading and performing salt fog corrosion. We thank all our DoD and DoE partners for their program guidance and provision of test standards. This research was supported in part by the U.S. Department of Defense Contract DACA72-02-C-0025, through the Strategic Environmental Research and Development Program (SERDP), Pollution Prevention Program Manager Chuck Pellerin.

Executive Summary

GE Global Research along with partners at Crosslink Powder Coatings Inc., the Department of Defense, and the Department of Energy have successfully completed a Strategic Environmental Research and Development Program (SERDP) funded research project to develop an exterior-use, corrosion-protection powder coating that cures at a temperature of 120 °C within 30 minutes. This technology has been tailored for military ground support equipment constructed from temperature sensitive, chromated, T3 annealed, 2024 grade aluminum. The coating has been shown to simultaneously meet all screening performance criteria including impact toughness, hardness, salt-fog and SO₂ corrosion resistance, surface quality, and exterior durability. As part of this effort, the coating was produced at manufacturing scale at Crosslink Powder Coatings Inc. and subjected to more exhaustive qualification testing with partners at Air Force Research Laboratory, NavAir, and Honeywell DoE. These powder coatings are inherently free from volatile organic compounds, chromates, and hazardous air pollutants. Relative to the incumbent solvent-borne urethane paint system, the powder coating eliminates the need for a chromated primer and has the potential to increase application efficiencies by 35% while reducing raw material and paint facility operating costs. The project was awarded SERDP's Pollution Prevention 2004 Project of the Year.

SERDP's Pollution Prevention charter to abate environmental and health risks through the reduced use of toxic and volatile organic compounds and by minimizing hazardous waste production provided the driving force for this research effort. Each year the Department of Defense spends millions of dollars to procure, use, and dispose of thousands of pounds of toxic and hazardous materials associated with the use of solvent-borne corrosion-protection coatings. Powder coatings are an inherently solvent-free alternative and their use can help minimize health and environment risks while offering the potential for considerable cost savings. There are numerous examples of ground support equipment, weapon systems, and aircraft parts that require corrosion coatings but are made from temperature sensitive materials such as tempered aluminum. No commercial powder coatings are available today that can be applied to these substrates at temperatures low enough to avoid compromising their structural integrity. Addressing this gap in low temperature cure powder coating technology was the goal of this research project.

This project was lead by GE Global Research with an internal team of experts in synthetic chemistry, materials science, polymer processing. The effort was enhanced through collaboration with a commercial powder-coating producer who has several decades of powder coating formulation experience. Through this partnership, ideas and chemistries were quickly translated from the laboratory to the powder manufacturing line. Partners from DoD and DoE presented tremendous application, testing, and field repair experience. From inception to completion, representation and guidance from these potential end-users was key to aligning research developments with application requirements.

Project execution was performed in three main tasks, 1. Benchmarking performance and research of novel chemistries, 2. Translation of promising chemistries to full powder formulations for evaluation and optimization, and 3. Expanded qualification testing and evaluation of field reparability. All deliverables and milestones were met for these tasks on schedule and the project was completed on budget.

To initiate Task 1, commercial low temperature cure powder coatings, including candidates representative of all the major coating chemistries, were evaluated. Nearly all failed to adequately react at the requisite cure schedule of 120°C for 30 minutes, and none, even when prepared at their manufacturer's lowest recommended cure conditions, met the stringent performance needs for temperature-sensitive military applications.

In research of novel chemistries, an experimental assessment of commercially viable crosslinking reaction schemes was used to down select the acid/epoxy reaction as the most promising route to low temperature curing (≤ 120 °C) powder coatings. Suitable acid/epoxy reaction catalysts including tertiary amines, ammonium compounds, and metal complexes were identified and screened in the laboratory. Thermal analysis techniques were developed to aid evaluation of catalyst efficacy and a statistical design of experiments was carried out to study several commercially available catalysts. The effect of catalyst type and loading were assessed and ranked in terms of kinetic responses. Isothermal kinetics modeling was also used to predict and compare reaction rates over a range of temperatures. In a parallel investigation, several candidate corrosion inhibitors were screened in baseline coating formulations for both SO₂ and salt-fog corrosion resistance.

Building off Task 1 results, low temperature cure powder coatings were constructed from acid functional polyester resins with triglycidylisocyanurate crosslinker and critically examined in Task 2. The effects and interactions of the resin, catalyst, and corrosion inhibitor were determined as part of this work. Through statistical experimentation, improvements were made in coating quality and a foundation was set for subsequent formulation refinements. A particular challenge was faced in meeting surface quality requirements while maintain mechanical properties. These were overcome by bringing together research developments in catalyst, resin type, corrosion inhibitor, flow additive, pigment concentration, and powder particle size.

Convergence to a final coating system was achieved through optimization studies. In this work, two critical components of the coating formulation, catalyst content and the ratio of resin to crosslinker, were tailored. Adhesion, hardness, chemical resistance, and exterior durability were shown to robustly meet specification requirements at all design levels investigated. Surface quality, 60° gloss, and toughness were found to be more strongly responsive to the formulation changes. Within the design space, a coating formulation was identified that met the low temperature cure specification and simultaneously passed all military ground support equipment requirements for exterior durability, toughness, chemical resistance, gloss, and surface quality. This solution was down-selected for final qualification testing and field repair evaluation in Task 3.

As part of expanded qualification testing in Task 3, the chemical strippability of the developmental coating was confirmed and the cleanability requirement was met using a selection of approved Qualified Product Listing (QPL) cleaners. The color target and stability to heat treatment were also verified. Additionally, refinement of the coating's flow additive system and augmentation of the crosslinker with a functional polyacrylate were shown to bring higher levels of cleanability and improvements in surface quality. A complete field repair evaluation was performed and acceptable adhesion and compatibility with existing patch systems was demonstrated. Lastly, cyclic and filiform corrosion resistance was studied and, per the request of military partners, UV-B weathering testing was conducted.

Towards further improving coating performance for more stringent toughness and chemical resistance requirements demanded by military aircraft, a novel GE resin was studied in low temperature cure powder coating formulations. This work built off the candidate solution for military ground support equipment. Incorporation of the GE resin was shown to simultaneously improve impact toughness and chemical resistance to levels required for aircraft applications. To a large degree this was achieved without compromising other physical properties but further optimization, particularly with respect to surface quality and color stability, would be necessary to arrive at a complete solution for aircraft.

During the course of this project, research results have been submitted and accepted for publication in peer reviewed journals and progress has been shared in conference, workshop, and symposium posters and presentations. Crosslink Powder Coatings Inc., the manufacturing partner for the coating product, has developed a viable production method that can support future needs for this powder technology. To translate this technology to the next stage of demonstration and validation, partners from the Air Force Research Laboratory and Material Command at Wright Patterson Air Force Base are planning to lead the submission of an Environmental Securities Technology Certification Program (ESTCP) project proposal.

Objective

In a 2-year program, a team comprised of large and small private industry (GE Global Research and Crosslink Powder Coatings, Inc.), DoD (NavAir and U.S. Air Force), DoE (Honeywell, KCP) has developed a low temperature curing powder coating for temperature sensitive substrates. The coating cure requirement is at or below 120 °C within 30 minutes. This is dictated by the temperature sensitive nature of aluminum alloys that are used in several types of military equipment. Due to their heat treatment, prolonged exposure to temperatures above 120 °C can compromise the structural integrity of these materials. Specifically, this powder coating has been designed for use on chromate pretreated, T3-annealed, 2024-grade aluminum. The primary application target for this effort is ground support equipment. The solution concurrently meets all performance criteria for an exterior durable, corrosion protection coating while offering the added benefits of zero solvent emissions and corrosion resistance without use of chromates in the coating itself. GE has led the program and applied its polymer chemistry, reaction catalysis, and powder coating expertise to address the need for a VOC-free, non-toxic, non-hazardous coating. The team has developed novel formulation chemistries, catalyst systems, and complete powder formulations, and has tested conformance to property requirements and demonstrated compatibility with existing field repair techniques.

Project Background

SERDP's Pollution Prevention program has identified the need to abate environmental and health risks by eliminating toxic and volatile organic compounds and by minimizing hazardous solid and liquid waste production. In addition to environmental and health benefits, these changes may afford considerable cost savings by avoiding fines for non-compliance to federal, state, and local mandates (from agencies including EPA, OSHA, and California's Air Quality Management Districts) and to regulations such as the Clean Air and Water Acts, NASHAP, CERCLA, and RCRA. The DoD currently spends millions of dollars each year to procure, use, and dispose of thousands of pounds of toxic and hazardous materials associated with the use of solvent-borne corrosion-protection coatings. Powder coatings have the potential to eliminate more than 95% of the toxic and hazardous materials used in the production and application of such coatings. There are numerous examples of aircraft parts, weapon systems, and support equipment that require corrosion coatings but are made from temperature sensitive materials such as tempered aluminum. No commercial powder coatings are available today that can be applied to these substrates at temperatures low enough to avoid compromising their structural performance.

Chapter 1: Performance Evaluation of Commercial Low Temperature Curing Powder Coats for Durable, Corrosion Resistant Applications

Abstract

As part of a Strategic Environmental Research and Development Program (SERDP) several commercial powder coatings have been evaluated as low temperature curing, weatherable, corrosion protection coatings for potential use on military aircraft, weapons systems, and ground support equipment. The performance of the coatings with respect to application specifications is reported. Powder coating chemistries investigated include polyester/triglycidal isocyanurate (PE/TGIC), epoxy, acrylic, polyester/Primid, and urethane. All powders were cured according to their manufacturer's lowest recommended cure schedule. Only the epoxy powder coating meets the low temperature cure requirement of 120 °C within 30 min., but it suffers poor weatherability. The PE/TGIC, urethane, and acrylate meet the weathering specification, but these fall short of the low temperature cure requirement. All commercial chemistries tested are deficient in impact strength.

Introduction

This report summarizes the performance evaluation of commercial powder coatings performed as part of a Strategic Environment Research and Development Program (SERDP) contract to develop a low temperature, weatherable powder coating for military applications. The coating cure requirement is at or below 120 °C within 30 minutes. This is dictated by the temperature sensitive nature of the AL2024 grade aluminum that is used in several types of military equipment. Due to the T3 heat treatment, prolonged exposure to temperatures above 120 °C can compromise the structural integrity of the metal. In addition to the low temperature cure target, the final coating must also meet functional requirements for corrosion and chemical resistance, adhesion, impact strength, and UV stability. Benchmarking of commercially available powder coatings for the SERDP program is needed to appraise current state-of-the-art powder coatings. The results will be compiled into a performance database against which the progress of this project will be compared and gauged.

This program was executed with several government partners and a powder-manufacturing subcontractor. The government agencies include Navair (Patuxant River), Air Force Research Laboratory (WPAFB), and Department of Energy (Honeywell--Kansas City Plant). These partners assisted in testing and evaluation of new materials. Because these partners are also potential end users of the powder coating their input has been integral for defining the performance targets. Crosslink Powder Coating, Inc. of Clearwater, Florida, manufactures powder coatings and helped to develop the low temperature formulations. Figure 1.1 shows a high level overview of the project including potential applications such as aircraft, ground support equipment, and weapons systems.

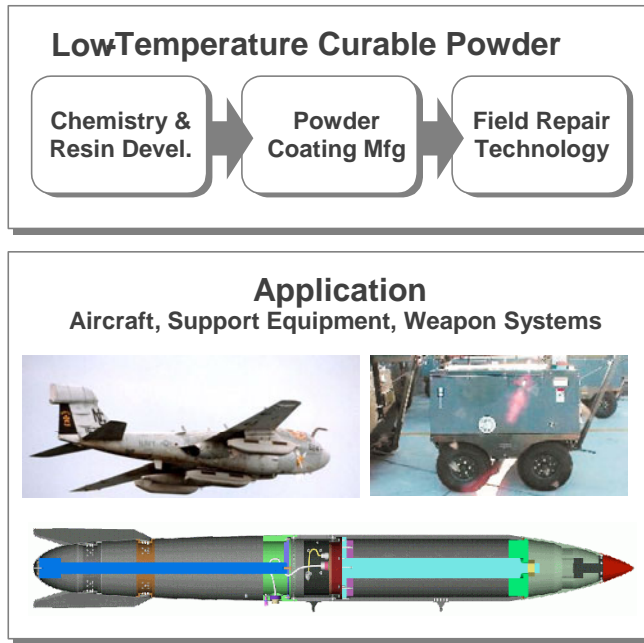

Figure 1.1 Project overview and application illustration.

Experimental

Materials and Test Substrates

Commercially available low temperature cure powder coatings were acquired from several powder coating manufacturers. These materials, listed in Table 1.1, were sampled according to the manufacturer’s recommendation as their best low temperature cure solution. Powder chemistries sampled include polyester/triglycidal isocyanurate (PE/TGIC), polyester/Primid, epoxy, urethane, and acrylate.

Table 1.1 Commercial powders.

Chemistry	Company	Product ID #	Lowest Cure	Standard Cure
PE/TGIC	Valspar	JHI-125-4	20' @ 148 °C	20' @ 163 °C
PE/TGIC	PPG	PCT73106	15' @ 148 °C	20' @ 191 °C
PE/TGIC	H.B. Fuller	IF50002M	_*	10' @ 177 °C
PE/TGIC	Dupont	PFC400S9	35' @ 163 °C	10' @ 204 °C
PE/Primid	CPC	55928	30' @ 154 °C	10' @ 180 °C
Urethane	Morton	1028HY2	20' @ 177 °C	20' @ 177 °C
Urethane	H.B. Fuller	IF2183M	15' @ 204 °C	15' @ 204 °C
GMA Acrylic	PPG	PCC10143	15' @ 148 °C	12' @ 177 °C
Epoxy	Morton	10-7199	15' @ 121 °C	15' @ 135 °C
Epoxy	Crosslink	798108	15' @ 150 °C	20' @ 180 °C

*alternative low cure schedule unavailable from manufacturer

The substrates used for this project are reported in Table 1.2. Aluminum, 2024T3, is a common alloy used in military equipment that is being targeted for powder coating. The 2024 alloy is composed of 4.4% copper, .6%, and 1.5% magnesium. Aluminum accounts

for the rest of the alloy. The T3 designation indicates that the material is solution heat-treated followed by cold working.² This material is used in both screening and qualification testing. The AL2024T0 is a softer version of the same alloy, and is required for flexibility testing. The T0 designation indicates that the alloy is annealed to improve ductility. The steel substrate, 1008 B-952 is standard for impact testing. Within the scope of this report all testing will be screening. In later qualification testing, bare (non-chromated) aluminum will be included for extreme stressing of coating protective capability.

Table 1.2 Test substrates .

Manufacturer	Part #	Type	Testing Use	
			Screen	Qualify
Q Panel Lab Products	N/A*	Aluminum 2024T3 chromated	√	√
Q Panel Lab Products	N/A*	Aluminum 2024T3 bare		√
Q Panel Lab Products	N/A*	Aluminum 2024T0 anodized	√	√
Act Laboratories	APR29650	Steel 1008 B-952	√ †	√

* Special order panels
† steel screened for corrosion and adhesion performance only

Thermal Analysis

Differential Scanning Calorimetry (DSC) experiments were run using a Perkin-Elmer DSC-7. All powders were first subjected to scanning DSC at 10 °C/min to evaluate T_g, onset, and peak exotherm temperatures. The total heat of reaction integrated from the exotherm was also evaluated. Selected powders were further evaluated using isothermal DSC held at 120 °C for 30 min., followed by quenching and then a follow-up scan at 10 °C/min. This allowed evaluation of the heat of reaction at the target cure condition, the cured powder T_g, as well as any residual reaction not picked up in the isothermal hold at 120 °C.

Sample Preparation

Prior to coating, test substrates were wiped with MEK. All powders were applied in a Flexicoat[®] manual powder coating booth using a Nordson SureCoat[®] cup gun with the gun voltage set to 70 kV, flow rate set to 30 psi, and rinse rate set to 20 psi. Curing was performed in a Blue M Convection oven. Final film thickness was measured with an Electrophysik Minitest 4100 thickness gauge operating on the Eddy Current principle. For each panel, mean thickness and standard deviation is reported based on 6 measurements. After curing, panels were held at ambient conditions for a minimum of 24 hours before mechanical testing.

Property Evaluation

SO₂ and salt fog corrosion testing was performed using standard ASTM test methods G85 and B117, respectively. Tests were performed on steel and aluminum substrates. Salt fog tests were performed at Honeywell-DOE, and the results are reported in hours to

failure. SO₂ tests were run at Navair, and the results are reported in creep as defined in ASTM D1654-92.

Adhesion testing was performed using a Gardner crosshatch knife and Permacel[®] tape. This test was done in accordance with ASTM D3359. Flexibility testing followed ASTM D522 and was performed with a Gardner mandrel bend tester.

Impact strength was tested in accordance with ASTM D5420. A Gardner impact tester, capable of imparting discrete impacts from 0-160 in/lbs, was used for all impact testing. Pencil hardness testing was performed following ASTM D3363.

Solvent resistance was determined using the MEK double rub test. For this test, the head of a 2-pound hammer is wrapped in cheesecloth saturated with methyl ethyl ketone. The hammer is then pulled back and forth along a six-inch path on the sample. One forward and back rub counts as a single double rub. The cheesecloth is re-saturated with MEK every 25 double rubs. This test continues until the substrate is exposed or until a maximum of 200 rubs is reached without failure.

For accelerated weathering testing an Atlas Ci35a Xenon Weatherometer was used. To assess performance, color coordinate measurements were collected as a function of exposure using a Macbeth Colorimeter following ASTM D2244. The ΔE of each coating is reported after 2000 hrs of UV exposure.

Finally, the surface quality of the powder coatings was determined using a BYK Gardner Wavescan[™] Distinctness of Image (DOI) instrument. A calibration curve was generated relative to Powder Coating Institute (PCI) surface quality standards. The results are reported in PCI units ranging from 1-10, with 10 corresponding to the best quality.³

Results and Discussion

Performance Specifications

Extensive documentation including a military Joint Test Protocol⁴, Air Force Protocol⁵, and a Military Specification⁶ summarize the military's requirements for corrosion protective powder coatings. A wide range of performance specifications must be simultaneously met in the applied coating. These documents were reviewed in detail and customer input was used to distill out all material property requirements for the final coating. These specifications are summarized in a single scorecard shown in Table 1.3. For each property the scorecard identifies a specific test, the spec limits, and the type of substrate on which the coating should be applied for evaluation. Additionally, tests are identified as screening and/or qualifying for final coating performance.

Table 1.3 Performance specifications.

Property	Test Performer	Substrate	Screen	Quality	Test	Units	*LSL	*USL
Thickness	GEGR	All	√	√	Eddy Current	mils	2.3	3.2
Corrosion Resistance	Honeywell	AL2024 T3 Chromated & CRS-1008 B952	√	√	Salt Fog Corrosion Resistance ASTM B-117	hrs.	2000	-
	Navair	AL2024 T3 Chromated & CRS-1008 B952	√	√	SO ₂ Corrosion Resistance ASTM G85	hrs.	500	-
	AFRL	AL2024 T3 Chromated & CRS-1008 B952		√	Cyclic Corrosion Resistance on scribed steel GM 9540P	cycles	80	-
	Navair	AL2024 T3 Chromated & CRS-1008 B952		√	Filiform Corrosion Resistance ASTM 2803-93	in.	0.25	-
	Navair	AL2024 T3 Chromated & CRS-1008 B952	√	√	Electrical Impedance Spectroscopy	Ω*cm ²	10 ⁹	-
Adhesion	GEGR	AL2024 T3 Chromated	√	√	Crosshatch Adhesion ASTM D3359-97	ASTM Scale	4B	-
	GEGR	AL2024 T0 Anodized	√	√	Mandrel Bend ASTM D522-93	Failure Dia. in.	-	0.25
Mechanical Properties	GEGR	CRS-1008 B952	√	√	Gardner Impact Test ASTM D-5420 in accord. w/ MIL-C-24712A	in-lbs	150	-
	GEGR	AL2024 T3 Chromated	√	√	Pencil Hardness Test ASTM D3363 in accord. w/ MIL-C-24712A	Pencil#	2H	-
Storage Stability	GEGR	-		√	12 Month Storage ASTM D1849-95	%gel	-	0
	GEGR	-	√	√	PCI #1 Accelerated Storage 24hrs. at 45°C	days	-	-
Weathering	GEGR	AL2024 T3 Chromated		√	QUV-B Weathering	hrs.	500	-
	GEGR	AL2024 T3 Chromated	√	√	Xenon Arc Accelerated Weathering ASTM G26-96	Delta Color	-	2
Chemical Resistance	GEGR	AL2024 T3 Chromated	√		MEK Double Rub ASTM D 5402	Double Rubs	200	
Reaction Kinetics	GEGR	-	√	√	Gel Time @ 180°C	secs.	-	-
	GEGR	-	√	√	Pill Flow @ 65 degrees to the horizontal	mm	-	-
	GEGR	-	√	√	Dielectric Cure Analysis	time	-	-
	GEGR	-	√	√	Differentially Scanning Calorimetry (DSC)	% cure at 120°C - 30min	100	-
Heat Resistance	GEGR	AL2024 T3 Chromated		√	4 hrs. @ 250°F	Delta Color	-	1
Surface Quality	GEGR	AL2024 T3 Chromated	√	√	DOI Wavescan	PCI Standard	-	-

Initial Screening and Down Selection

Screening of each powder coating was performed using DSC to determine the pre-cure T_g, reaction onset, and peak reaction temperature. The best candidates from each chemistry were down-selected for further evaluation based on the lowest peak reaction temperature.

Table 1.4 DSC screening results for low temperature cure.

Down-Selected for Further Study	Chemistry	Company	Product	DSC 10 °C/min		
				Resin Tg (°C)	Onset Temp (°C)	Peak Temp (°C)
√	PE/TGIC	Valspar	JHI-125-4	65	130	152
	PE/TGIC	PPG	PCT73106	71	143	166
	PE/TGIC	H.B. Fuller	IF5002M	61	132	176
	PE/TGIC	Dupont	PFC400S9	70	120	182
√	PE/Primid	CPC	55928	61	-	-
√	Urethane	Morton	1028 HY^2	62	180	208
√	Urethane	H.B. Fuller	IF2183M	49	175	220
√	GMA Acrylic	PPG	PCC10143	58	130	167
√	Epoxy	Morton	10-7199	58	126	143
	Epoxy	Crosslink	798108	62	131	160

Property Evaluation of Down Selected Powders

Down-selected powders were further evaluated using the isothermal DSC method described in the experimental section. The measured heat of reaction at the cure condition of 120 °C for 30 minutes is plotted in Figure 1.2. Only PE/TGIC, epoxy, and acrylate powder coatings yielded detectable reactions. Lack of reaction in the urethane chemistry can likely be attributed to the high temperature (typically between 160 –170 °C) required for de-blocking the isocyanate.⁷ Likewise, the PE/Primid chemistry showed no heat of reaction at 120 °C due to the melting point (120-124.5 °C) of the Primid curing agent. Of the three chemistries that show reaction, the epoxy achieved the highest heat of reaction, 77 J/g, followed by the acrylate with 55 J/g, and then the PE/TGIC with 17 J/g. Although the acrylic showed the fastest initial reaction rate, the epoxy, after a delayed onset, quickly overtook it. The PE/TGIC yielded the lowest reaction rate and the lowest heat of reaction.

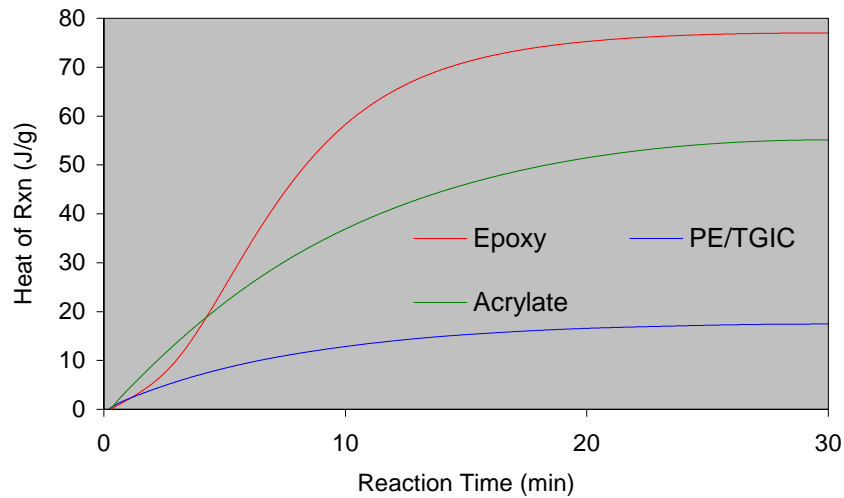

Figure 1.2 Heat of reaction is plotted vs. time for commercial benchmarks at the target cure condition of 120 °C for 30 minutes. The PE/Primid and the urethane showed no heat of reaction at 120 °C.

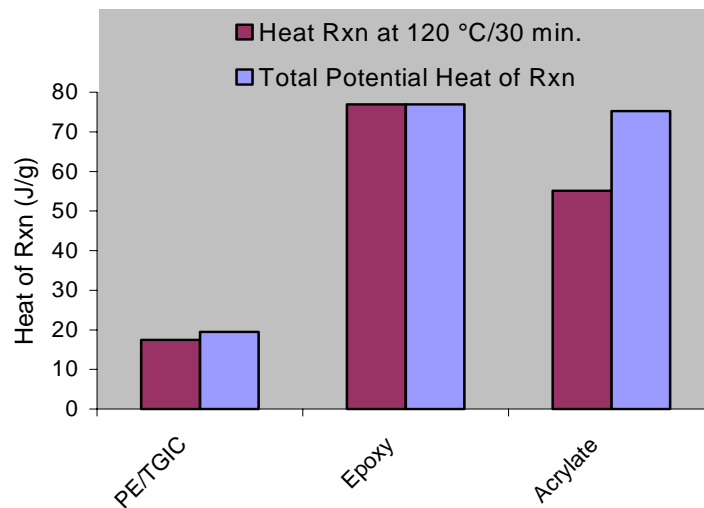

Figure 1.3 Heat of reaction at 120 °C vs. total potential heat of reaction.

In Figure 1.3, the total potential heat of reaction (which includes any residual exotherm recorded in a follow-up scan) is compared to the actual heat of reaction realized at 120 °C within 30 min. Differences in total heat of reaction are attributable to the differences in reaction chemistries. To a good approximation, both the epoxy and PE/TGIC reach their total potential within 30 min., specifically, the epoxy reaches 100% and the PE/TGIC reaches 90%. This suggests that epoxy based reactions offer good potential for low temperature cure. The acrylate falls 25% short of its total potential heat of reaction under

the same cure schedule. Epoxy resins because of their aromatic structure perform poorly in weathering tests whereas PE/TGIC and acrylates do well. This deficiency is seen in Xenon arc testing presented in a later section.

The down-selected powder coatings were prepared at the manufacturer’s recommended lowest cure conditions summarized in Table 1.5. All powders were applied to achieve a cured film build within the specification range of 2.3-3.2 mils. Table 1.5 shows the results from the evaluation of these powders. Each response is color-coded indicating whether the coating tested meets (green) or fails (red) specification requirements. Only surface quality, which does not have a defined spec limit, is not color-coded. As seen in table 1.5, all chemistries passed salt fog corrosion testing on aluminum, but only the epoxy fulfilled the specification of 2000 hrs on steel. Only PE/TGIC and the Polyester/Primid fulfilled the SO₂ corrosion requirement for both steel and aluminum. With the exception of the Polyester/Primid chemistry, the benchmark powders all showed outstanding adhesion and flexibility properties.

Table 1.5 Screening evaluation of commercial benchmark materials.

				PE/TGIC Valspar (JHI-125-4)	PE/Primid CPC (55928)	Urethane Morton (1028 HY^2)	Epoxy Morton (10-7199)	Acrylate PPG (PCC10143)
Lowest Mfr. Cure Schedule				20min-148°C	30min-154°C	20min-177°C	15min-121°C	15min-148°C
Thickness	Eddy Current	2.3	3.2	2.69	2.85	2.32	2.66	2.97
Corrosion Resistance	SaltF. Corr. (AL)	2000	-	2000	2000	2000	2000	2000
	SaltF. Corr. (Steel)	2000	-	<1576	<1081	<1576	<2085	674
	SO ₂ Corr. (AL)	7	-	8	8	5	5	5
	SO ₂ Corr. (Steel)	7	-	9	10	9	5	6
Adhesion	Crosshatch	4B	-	5B	4B-5B	5B	5B	5B
	Mandrel Bend	-	0.25	<0.125	>1	< 0.125	< 0.125	< 0.125
Mechanical Properties	Gardner Impact	150	-	40	20	80	20	20
	Pencil Hardness	2H	-	H	HB	HB	HB	H
Weathering	Xenon Arc	-	2	0.5	5.6	0.6	2.8	-
Chem Resist	MEK Test	200	-	184	79-80	62	> 200	67
Surf. Quality	Wavescan	-	-	3.6	5	4	4.25	8 (visual)

Impact strength, and hardness are properties that are consistently deficient for all powders, while chemical resistance is deficient in all powders except the epoxy. The impact results for each of the five powder coatings are well below the specification of 150 in/lbs direct impact. Only the urethane powder coating exhibited significant impact strength at 80 in/lbs, but this chemistry has a minimum cure temperature of 177 °C, which is well above the required 120 °C. With respect to hardness the underperformance is not so severe. While all the powders fall short of the 2H hardness specification, the PE/TGIC and the acrylate chemistries were within one pencil hardness unit of the target. The urethane, epoxy, and PE/Primid fell within two units of the target. For chemical resistance only the epoxy achieved 200 double rubs, and while the PE/TGIC showed promise at 184 double rubs all other chemistries fell short.

Weatherability was evaluated using a xenon arc weatherometer and color change was measured as a function of exposure. The specification requirement defines failure as exceeding a ΔE value of 2 after 2000 hrs of exposure. Consequently, only the PE/TGIC and the urethane fulfilled this requirement maintaining a ΔE of .5 and .6 respectively. The epoxy failed, due to gloss loss and chalking, after only 212 hrs of exposure. The PE/Primid maintained gloss, but yielded a ΔE of 5.6 after 2000 hrs of exposure. A response is not reported for the acrylate because it is a clear coat over steel. Follow-up of the acrylate on a white substrate is underway to assess the clear coat's ability to protect the underlying substrate.

Cure Investigation

Up to this point all powders have been cured and studied at what the manufacturer recommends as the lowest cure temperature. At the standard cure conditions, the manufacturers report their impact performance and solvent resistance to be higher than what was recorded here. To more closely study the effect of cure temperature, samples of the Valspar polyester/TGIC were prepared at three cure conditions: the low temperature target (120 °C/30min.), the manufacturer's lowest recommend (148 °C/30 min.), and the manufacturer's highest recommend (163 °C/30 min.). These samples were then evaluated in impact strength and solvent resistance tests.

Improvements in both chemical resistance and impact strength are experienced as a function of increasing cure temperature as shown in Figure 1.4. Inadequate cure at low temperature may be one explanation for the poor mechanical properties and chemical resistance.

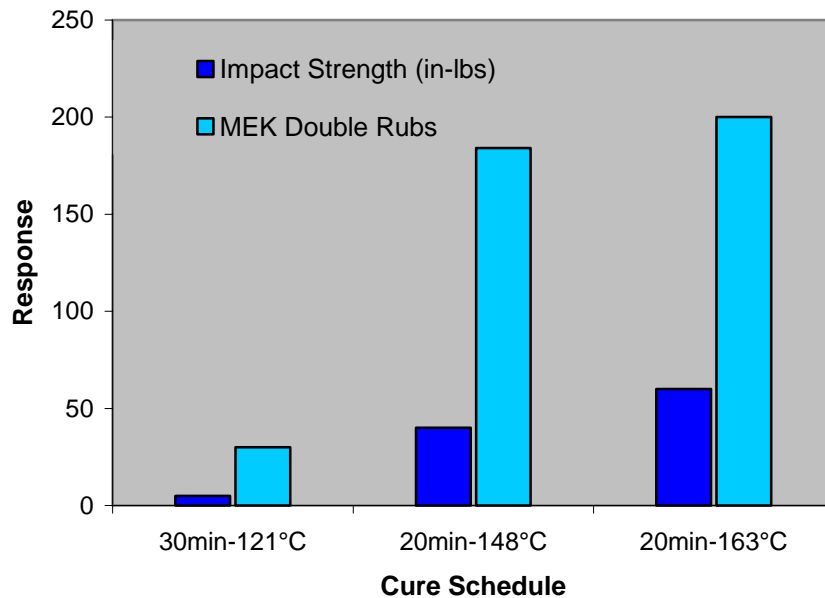

Figure 1.4 Impact Strength and MEK double rubs as a function of cure condition.

Conclusions

Commercially available low temperature powder coatings were sampled and characterized. Powder coating chemistries including polyester/TGIC, polyester/Primid, urethane, epoxy, and acrylate were included in this work. The performance has been gauged against military requirements and was found to fall short in several categories. Figure 1.5 summarizes the relative performance tradeoffs for each powder. In this plot all responses have been normalized from 0 to 1, where 1 corresponds to the highest level of performance. These results highlight the challenge of developing a low temperature powder coating that will simultaneously meet all the military specifications. In particular, combining acceptable chemical resistance, weathering, hardness, and impact strength in a single low temperature cure chemistry will be a formidable task.

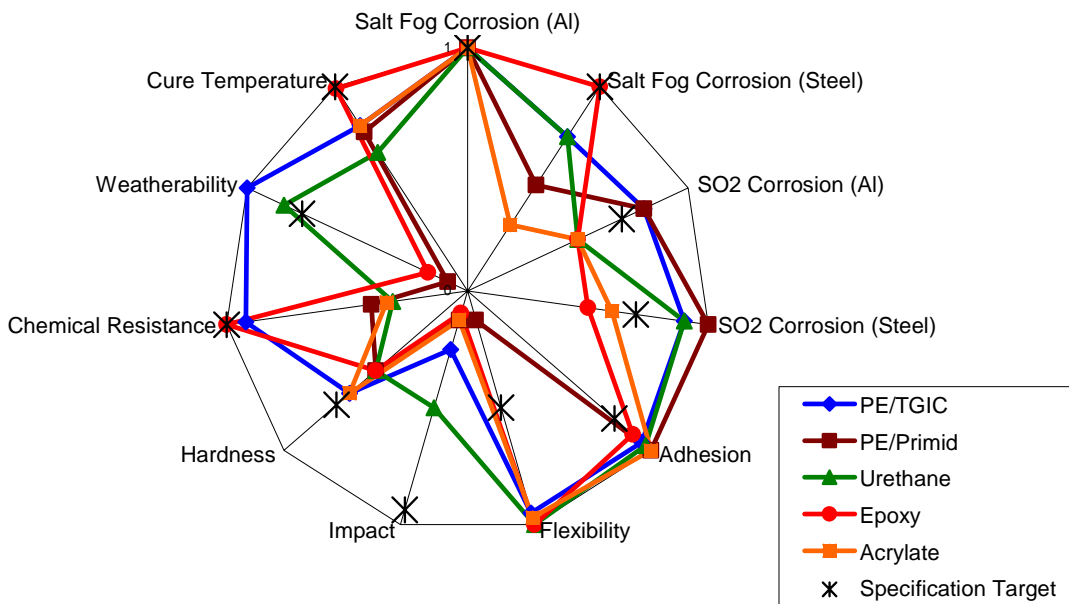

Figure 1.5 Radar plot showing property tradeoffs for powder chemistries studied. Responses have been normalized from 0 to 1, with 1 corresponding to the best performance, and the specification target indicated.

Acknowledgements

The authors thank Kevin Kovaleski at Navair (Patuxant River, MD) and Mark Smith at Honeywell-DOE (Kansas City, MO) for performance of SO₂ and salt fog corrosion testing, respectively, reported as part of this work. At GRC we thank Ersin Acar, Rainer Koeniger, Joe Suriano, and Ron Singh Warner for their assistance. This work was performed under SERDP contract number DACA72-02-C-0025.

References

1. SERDP Contract Number DACA72-02-C-0025.
2. J.E. Hatch, Aluminum: Properties and Physical Metallurgy. Materials Park, OH: ASM International, 1984. p. 354, 136.
3. BYK Gardner website at: www.bykgardner.com
4. Joint Test Protocol J-99-OC-014-P, For Low/No VOC & Nonchromated System for Support Equipment. Science Applications Int. Inc., Warner Robins, GA 31088. Nov. 4th, 1999. Rev. July 26th, 2000.
5. Interim Air Force Test Protocol ZHTV01G507 for Alternatives to Volatile Organic Compounds (VOCs) and Hazardous Air Pollutants (HAPs) in Primers and Topcoats for Non-flight-critical Components. HQ AFMC/LGP-EV. 4375 Chidlaw Road, Room C-109, Wright-Patterson AFB OH, 45433.
6. Military Specification MIL-C-85285B, Coating Polyurethane, High-Solids. US Government Printing Office. Amendment 2, Oct. 22nd, 1990.
7. Wicks, Douglas A., Wicks, Zeno W., "Blocked Isocyanates III: Part A. Mechanisms and Chemistry," Progress in Organic Coatings vol. 36, p. 148-172, 1999.

Chapter 2: Development of Low Temperature Curing, 120 °C, Durable, Corrosion Protection Powder Coatings for Temperature Sensitive Substrates

Abstract

Commercial low temperature cure powder coatings, including candidates representative of all the major coating chemistries, were evaluated and nearly all failed to adequately react at a cure schedule of 120°C for 30 minutes, and none, even when prepared at their manufacturer's lowest recommended cure conditions, meet the stringent performance needs for temperature-sensitive military applications. Initial research is presented toward developing low temperature cure powder coatings that simultaneously meet all performance requirements at this target cure schedule. Using commercial resins, corrosion inhibitors, and catalysts, this research effort has closed gaps in low temperature cure coating performance and has helped to identify critical deficiencies. This study establishes direction for future developments in new resin and catalyst technologies.

Introduction

Significant effort is expended and cost is incurred each year to procure, use, and dispose of toxic and hazardous materials associated with the use of solvent-borne corrosion protection coatings. Powder coatings have the potential to eliminate more than 95% of the volatile organic compounds and hazardous air pollutants released during the production and application of such coatings. Over the past years powder coatings have increasingly gained popularity as a result of not only their ecological advantages but also for their economical and performance benefits.¹⁻⁵ There are numerous military and civilian applications that require protective coatings but involve substrates that are made from materials such as low-tempered metal alloys, composites, plastic, or wood that would be structurally compromised by thermal treatments required to cure conventional powder coatings. The need for powder coatings that cure at ever lower temperatures has been presented extensively and much work on their development has been reported in the literature.⁶⁻²²

This paper highlights research to develop a weatherable powder coating that cures at or below 120 °C within 30 minutes. For specific military applications, this cure schedule is dictated by the temperature sensitive nature of 2024-grade aluminum alloy that is used in several types of aircraft parts, weapon systems, and support equipment. Due to the T3 heat treatment, prolonged exposure to temperatures above 120 °C can compromise the structural integrity of the alloy. In addition to the low temperature cure target, the final coating must also meet functional requirements for corrosion and chemical resistance, adhesion, impact strength, and exterior durability. With the help of research and qualification partners representing several military and government agencies, a comprehensive list of coating performance specifications and tests was compiled from military specification reports and joint test protocols. An abbreviated summary of the performance criteria is provided in Table 2.1. Only surface quality lacks a quantified specification target at this time.

Table 2.1 Target performance specifications for 120 °C – 30 min cure powder coating

Property	Test	Units	Specification*	
			LSL	USL
Thickness	Gauge (eddy current, magnetic induction)	mils	2.3	3.2
Adhesion	Crosshatch ASTM D3359-97	ASTM scale	4B	-
Flexibility	Mandrel Bend ASTM D522-93	failure dia. in.	-	0.25
Toughness	Direct Impact ASTM D5420	in-lbs	150	-
Hardness	Pencil Hardness ASTM D3363	pencil #	2H	-
Exterior Durability	Xenon Arc, 2000 hrs ASTM G26-96	delta color	-	2
Chemical Resistance	Skydrol Fluid Immersion, 7 days	delta pencil #	-	2
	MEK Double Rub ASTM D5402	double rubs	200	
Color Match	Colorimetry ASTM D2244	delta color	-	2
Gloss	60° Gloss ASTM D523	gloss units	90	-
Surface Quality [†]	DOI Wavescan, calibrated to PCI standards	standard #	-	-
Corrosion Resistance	Salt Fog, ASTM B117	hrs to failure	2000	-
	SO ₂ 500 hrs, ASTM G85	scribe undercut rating	7	-
	Cyclic on scribed steel GM 9540P	cycles to failure	80	-
	Filiform ASTM 2803-93	in.	-	0.25

*LSL = lower Spec Limit; USL = Upper Spec Limit

[†]Specification not yet defined

This report presents the results from benchmark evaluation of several state-of-the-art low temperature cure powder coatings. Additionally, progress from early efforts to develop powder coatings specifically for a 120 °C – 30 min cure schedule is evaluated against performance targets.

Experimental

Materials and Test Substrates

All materials used in this study, including finished powders and raw materials, were used as received from their manufacturers. In formulation studies, four grades of acid functional polyester resins, denoted A, B, C, and D with corresponding equivalent molecular weights of 1700, 1600, 1630, and 1650 were combined 93:7 with triglycidylisocyanurate (TGIC) (Araldite PT 810, Huntsman Chemical). Three different catalysts were used in this work: choline chloride (Actiron CC6, Synthron Incorporated), and two benzyltrimethylammonium halides (chloride and bromide salts, both from Aldrich Chemical). Two types of corrosion inhibitors were used: zinc phosphate (Halox, Rockwood Pigments), and barium metaborate (Butrol 23, Buckman Laboratories).

Chromated aluminum, 2024T3, was the primary substrate for this research. For testing coating flexibility a softer T0 annealed version of the same alloy was used with an anodized surface treatment. All aluminum test substrates were obtained from Q-Panel Lab Products. For standardized impact testing, untreated 1008 steel panels (R-46, Q-Panel Lab Products) were used.

Melt Compounding and Powder Grinding

Raw materials were dry blended by either hand shaking in a bag (1 min) or in a Henschel mechanical mixer (60 sec at 2000 rpm). Formulations were then melt-mixed on a 50 mm twin-screw extruder (lab model Baker Perkins) at 500 rpm with a max barrel temperature of 88 °C. Extrudate was passed through water-cooled pinch-rolls and collected onto a stainless steel belt; from exit of the extruder, approximately 60 sec. was required to reach ambient temperature. Powder grinding was performed using an air classifying mill, ACM-5, followed by sieving through a 140 mesh screen. This process produced powders with a mean size of 40 - 50 microns (95% < 105 microns) as measured using a Malvern Series 2600 laser analyzer.

Thermal Analysis

Samples, 15-20 mg in size, were analyzed using a Perkin Elmer DSC 7. The testing protocol utilized an isothermal hold at 120 °C for 30 minutes followed by a rapid quench and then a temperature scan from 25-300 °C at 10 °C/min. Heat of reaction and the corresponding cured powder percent conversion curve were obtained from the isothermal portion of the test while the cured network Tg and residual heat of reaction were assessed from the follow-up scan. Both heats of reaction were used to calculate actual percent conversion at 120 °C for 30 minutes.

Coating Preparation

Prior to coating, test substrates were cleaned with a MEK wipe. All powders were applied in an ETI Flexicoat[®] manual powder coating booth using a Nordson SureCoat[®] cup gun with an applied voltage of 70 kV, application pressure of 30 psi, and rinse rate setting of 20 psi. Curing was performed in a Blue-M convection oven. For each panel, mean coating thickness and standard deviation was monitored based on 6 measurements using an ElektroPhysik Minitest 4100. After curing, panels were held at ambient conditions for a minimum of 24 hours before testing.

Property Evaluation

Adhesion testing was performed using a Gardner crosshatch knife and Permacel[®] tape in accordance with ASTM D3359. Flexibility testing followed ASTM D522 and was performed with a Gardner mandrel bend tester. Direct impact strength was tested in accordance with ASTM D5420 using a Gardner impact tester. Pencil hardness was assessed following ASTM D3363. Solvent resistance was determined using the MEK double rub test, ASTM D5402, with failure report at substrate read-through.

SO₂ and Salt Fog corrosion tests were performed using standard ASTM test methods G85 and B117, respectively, on both steel and aluminum substrates. For salt fog testing, time to failure, assessed as greater than 1/8" undercutting from edge of scribe on coating, up to the test duration of 2000 hours is reported. For SO₂ testing, performance is reported as creep after 500 hours of exposure rated on an ASTM scale. A failure rating of 6 corresponds to undercutting from edge of scribe by more than 1/16".

For accelerated weathering an Atlas Ci35a Xenon Weather-Ometer[®] was used. To assess performance, color coordinates were measured as a function of exposure using a Macbeth

Colorimeter (Color-Eye 7000A) following ASTM D2244. The ΔE color change is reported after 2000 hrs of exposure.

Gloss was measured at 60° using a BYK Gardner Tri-Gloss Meter. Coating surface quality was determined using a BYK Gardner Wavescan™ Distinctness of Image (DOI) instrument calibrated relative to Powder Coating Institute (PCI) surface quality standards. Results are reported in PCI units ranging from 1-10, with 10 corresponding to the best quality. In samples where gloss was inadequate to allow use of the Wavescan, visual assessments were made by side-by-side comparison to the surface quality standards.

Results and Discussion

Commercial Low Temperature Cure Performance

To assess current state-of-the-art technology in low temperature cure powder coatings, product literature, websites, and technical support from many commercial manufacturers were consulted. Several best-in-class low temp curing powders were sampled from each of the major conventional chemistries including acrylate, epoxy, urethane, and polyester crosslinked using either triglycidylisocyanurate (TGIC) or hydroxyalkylamide (HAA). For each of the five chemistry families, DSC scans at 10 °C/min were used to down-select the fastest low temperature reaction kinetics based on onset and peak exotherm temperatures. The down-selected powders were then applied and cured as nominally 3 mil thick powder coatings according to their respective manufacturer's lowest recommended cure schedule and evaluated.

Key performance attributes for each coating are summarized in Table 2.2. These were evaluated using the corresponding test methodologies indicated in Table 2.1. The cure schedule used for each coating is also provided in Table 2.2. Responses that fail to meet Table 2.1 performance criteria have been shaded dark. Overall, there are tradeoffs among the chemistries and clearly no solution meets cure and performance expectations. When selected powders were prepared closer to their manufacturer's standard cure conditions, performance dramatically improved. These results underscore the challenge of designing a powder coating that can effectively crosslink at 120 °C within 30 min and simultaneously meet the performance goals of this research effort. This is further emphasized by the plot in Figure 2.1, which simultaneously compares each of the five candidate coatings relative to select specification targets.

Table 2.2 Commercial low temp cure powder coating performance

Property	Test	PE/TGIC	PE/HAA	Urethane	Epoxy	Acrylate
Cure Schedule*	-	148 °C 20 min	154 °C 30 min	177 °C 20 min	121 °C 15 min	148 °C 15 min
Adhesion	Crosshatch	5B	4B-5B	5B	5B	5B
Flexibility	Mandrel Bend	0.125	1	0.125	0.125	0.125
Toughness	Direct Impact	20	20	100	20	20
Hardness	Pencil Hardness	H	HB	HB	HB	H
Chem Resist	MEK Double Rub	184	80	62	200	67
Durability	Xenon Arc	0.5	5.6	0.6	2.8	-
Surface Quality†	PCI Standards	4	5	4	4	8
Corrosion Resistance	Salt Fog (AL)	>2000	>2000	>2000	>2000	>2000
	Salt Fog (Steel)	<1576	<1081	<1576	>2085	<674
	SO ₂ (AL)	8	8	5	5	5
	SO ₂ (Steel)	9	10	9	5	6

*manufacturer recommended lowest temperature cure schedule

Shaded responses indicate failure relative to performance requirements provided in Table 1

†Specification not defined

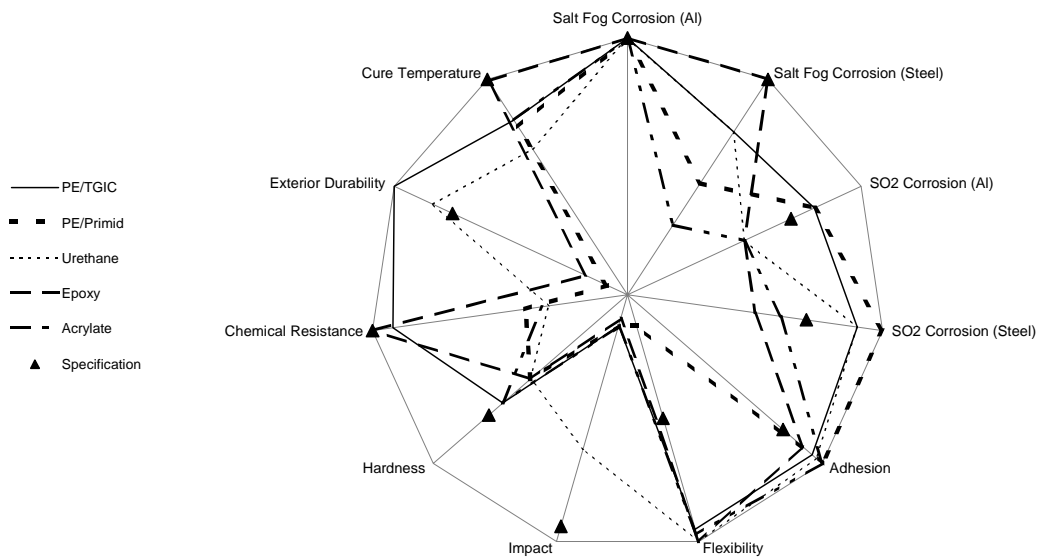

Figure 2.1 Star plot showing property tradeoffs for selected powder coatings prepared at their manufacturer's lowest recommended cure schedule. Responses have been normalized from 0 to 1, with 1 corresponding to the best possible performance. Specification targets are included for reference.

Many low temperature-curing limitations identified in Table 2.3 can be linked to the nature of the crosslinking mechanism or the base resin chemistry.²³ The acid/hydroxyl reaction is the least reactive mechanism represented. Its curing temperature is limited by the nature of the esterification reaction and the need to drive off water to obtain high conversions. HAA crosslinkers rely on this scheme. Slightly lower temperatures can be used to cure hydroxyl functional resins with protected or dimerized isocyanates to yield urethane coatings. However, the deblocking temperatures of the protective group or the ring-opening kinetics of the uretidione limit the minimum cure temperature to approximately 140 °C.^{24,25}

The other three coatings chemistries, PE/TGIC, epoxy, and acrylate, are all based on epoxy type reactions. These have the greatest potential for low temperature cure. Epoxies can crosslink with a variety of different chemical functionalities, such as acids, aromatic hydroxyls, amines, or even through catalyzed homopolymerization.²⁶ Use of bisphenol-A (BPA) and novolac-modified epoxies is effectively restricted to interior applications because of their poor weathering attributes. Poor exterior durability is evident in the epoxy coating in Table 2.3.²³ Cycloaliphatic epoxies do not suffer from the ultraviolet light instability of the aromatics but resins suitable for powder coatings are unavailable.

For exterior applications, acrylate resins functionalized with epoxy moieties such as glycidyl methacrylate are increasingly finding use. They offer excellent exterior durability and scratch resistance but many times this comes at the price of poor chemical resistance and brittleness. Acid functional polyesters are often combined with multifunctional epoxy crosslinkers, most commonly TGIC, to deliver both low temperature cure kinetics and exterior durability. Despite concerns about the potential toxicity of TGIC, there are no commercial alternatives that offer similar performance. Of the commercially available resins, PE/TGIC chemistry offers the best opportunity to develop 120 °C cure, exterior powder coatings with the properties outlined in Table 2.1. The next section presents development efforts toward achieving the low temperature cure and coating performance goals building on PE/TGIC chemistries.

Resin Screening Study

Four different commercial acid functional polyester resins were sampled from their manufacturers as candidates for low temperature curing powder coatings. These were incorporated into the general factorial screening study illustrated in Figure 2.2 wherein each of the four resins, combined 93/7 with TGIC crosslinker, were formulated with two different corrosion inhibitors, either zinc phosphate or barium metaborate, and a choline chloride catalyst at levels of 0, 0.3, or 0.5 percent of total formulation. Details on the powder formulations are given in Table 2.3. Sample panels of each of the twenty-four powder coatings produced in this design were prepared by curing at 120 °C for 30 min.

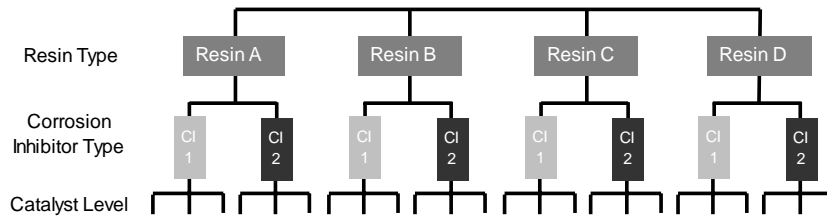

Figure 2.2 Experimental design for resin screening study. Twenty-four powder coatings were developed and evaluated using commercial acid functional polyester resins.

Table 2.3 Powder coating formulations used in resin screening experiments

Component	Formulation Number					
	1	2	3	4	5	6
Acid Polyester	65.0	65.0	65.0	65.0	65.0	65.0
TGIC	4.9	4.9	4.9	4.9	4.9	4.9
Curing Catalyst	0.0	0.3	0.5	0.0	0.3	0.5
Flow Promoter	1.5	1.5	1.5	1.5	1.5	1.5
Degassing Agent	0.5	0.5	0.5	0.5	0.5	0.5
Antioxidant	1.0	1.0	1.0	1.0	1.0	1.0
Zinc Phosphate	5.0	4.7	4.5	0.0	0.0	0.0
Barium Metaborate	0.0	0.0	0.0	5.0	4.7	4.5
Filler & Pigment	22.1	22.1	22.1	22.1	22.1	22.1
Totals	100	100	100	100	100	100

For the sake of rapid screening, the complete performance specification list was pared down to eight key performance attributes that include: adhesion, flexibility, toughness, hardness, chemical resistance, surface quality, and gloss. The corresponding tests for these are indicated in Table 2.1 and the screening results are summarized in Table 2.4. All test coatings met the 2.3 - 3.2 mil thickness specification.

Table 2.4 Resin screening summary

Test	Resin A						Resin B						Resin C						Resin D					
	A-1	A-2	A-3	A-4	A-5	A-6	B-1	B-2	B-3	B-4	B-5	B-6	C-1	C-2	C-3	C-4	C-5	C-6	D-1	D-2	D-3	D-4	D-5	D-6
Adhesion	0B	1B	2B	0B	3B	4B	0B	2B	4B	2B	5B	5B	4B	4B	3B	4B	4B	4B	4B	4B	5B	5B	4B	4B
Flexibility	0.75	N.F.	1	0.25	1	1	0.66	0.75	0.75	0.75	0.5	0.13	N.F.	0.5	N.F.	N.F.	N.F.	0.13	N.F.	0.13	N.F.	N.F.	N.F.	N.F.
Toughness	0	20	20	0	0	0	0	0	20	20	20	20	20	20	20	20	20	40	20	20	20	60	40	40
Hardness	H	H	F	F	F	H	2H	2H	2H	2H	2H	3H	2H	2H	2H	3H	H	H	H	2H	2H	2H	H	2H
Chem Resist.	4	4	7	3	21	73	8	10	30	10	110	85	122	116	106	68	136	178	77	199	200	125	67	96
60° Gloss	89	91	80	90	70	63	88	90	85	86	75	65	84	76	78	75	70	67	78	63	69	59	54	49
Surface Quality	4	4	4	4	4	5	4	4	4	4	4	5	3	5	3	3	4	4	4	5	4	5	5	5

N.F. = No Failure

Shaded responses indicate failure relative to performance requirements.

At a high level, the results in Table 2.4 show a significant effect of resin type on coating performance with Resin D systems, and in particular formulations D-2 and D-3, meeting the greatest number of the key performance goals. Compared to resin systems A and B, systems C and D offer simultaneous improvements in flexibility and chemical resistance, but, depending on corrosion inhibitor type, suffer slight to moderate reductions in gloss. Irrespective of resin system, use of barium metaborate appears to adversely effect gloss especially at higher catalyst loadings. Within the Resin D formulations, those with zinc phosphate and added catalyst outperform analogous formulations with barium metaborate, particularly in chemical resistance. Across all formulations investigated, including the best overall performers, the most severe deficiency is seen in direct impact toughness with values nowhere near the 150 in-lbs goal. These results emphasize the strong effect of component interactions and the potential for competing tradeoffs between performance attributes.

Many of the important factors that likely differentiate these four resins such as chemical structure, molecular weight, functionality, polydispersity, as well as type and level of pre-catalysis are not provided by their manufacturers. Without this information it is difficult to draw correlations between chemistry and performance. It is possible, however, to compare the reaction kinetics of the four resin systems to learn more about their differences and how these might affect coating performance.

Figure 2.3 is a compilation of plots for DSC measured heat evolution as a function of time at 120 °C for the four resin systems. Without catalyst addition (formulations 1 and 4 in each resin series), both the reaction rate and total evolved heat are strongly dependent on the base resin. This is not unexpected as manufactures commonly pre-catalyze their resins. The results in Figure 2.3 suggest resins A and B are less pre-catalyzed than resins C and D. In fact, without additional catalyst resin A does not show any appreciable reaction at 120 °C, whereas added catalyst has little effect on the total heat of reaction for resins C and D with average values of approximately 22 and 15 J/g respectively. The lesser pre-catalyzed resins, A and B, show the greatest increase in reaction rate and total exotherm with catalyst addition. In these same systems, corrosion inhibitor selection has a notable effect on reaction kinetics; relative to formulations with zinc phosphate, use of barium metaborate is associated with a faster reaction rate and higher total heat of reaction. This is consistent with the overall reduction in gloss observed with barium

metaborate. Moreover, barium metaborate with the highly pre-catalyzed resin D may have over accelerated the reaction producing network heterogeneity and causing a drop in chemical resistance.

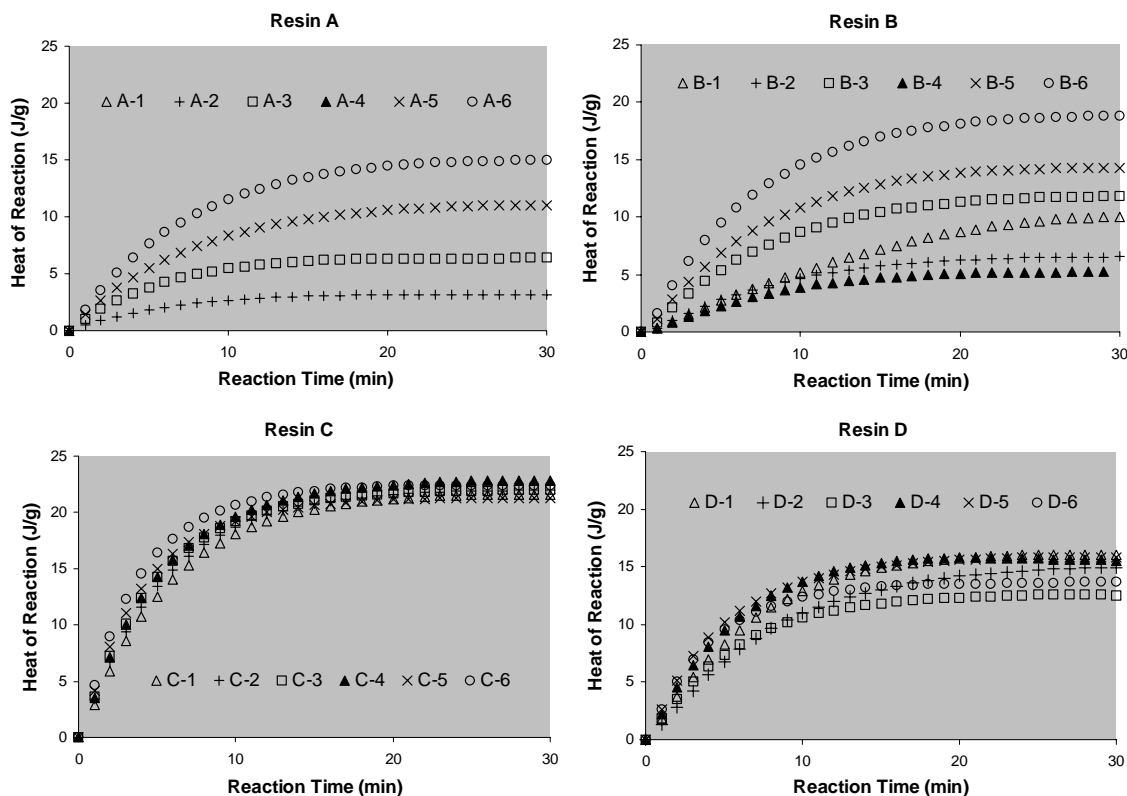

Figure 2.3 Heat of reaction at 120 °C versus reaction time for resin screening formulations. Legends indicate corresponding formulation numbers provided in Table 2.4. Note formulations A-1 and A-4 show no heat of reaction.

Using follow-up DSC scans, reaction conversion not realized after 30 min at 120 °C was measured for each of the twenty-four resin screening formulations. It should be noted that the crosslinked coatings made in this work have glass transition temperatures between 50 and 60 °C, and thus, at the 120 °C cure condition vitrification should not limit reaction conversion. The recovered residual heat of reaction was added to the 120 °C exotherm to calculate a total potential heat of reaction. From these data a percent conversion was calculated for the curing reaction at 120 °C.

For resins A and B, only certain combinations of catalyst and corrosion inhibitor yielded complete reaction conversion, whereas for resins C and D complete reaction conversion was attained in all formulations. For the most part the total potential heat of reaction was unaffected by formulation changes. Exceptions of note occur in resins B and D. Barium metaborate alone or the combination of zinc phosphate and choline chloride both acted to lower the total potential heat of reaction in resin B by about 35%. In resin D a choline chloride loading of 0.5% caused a 20% reduction in the total potential heat of reaction. This observation may be indicative of undesirable pre-reaction during processing that could have the effect of lowering the measurable exotherm.

Increased Catalyst

Higher catalyst loadings of 0.6 and 0.75% were investigated in resins C and D using only the zinc phosphate corrosion inhibitor. Adhesion and flexibility were unaffected by the increased catalyst levels while hardness, gloss and surface quality showed slight formulation specific changes. The lone exception was in resin D with 0.75% catalyst where both pencil hardness and gloss dropped significantly to values of F, and 55, respectively.

Combined with earlier results, direct impact and chemical resistance are plotted as a function of catalyst level in Figure 2.4. Resin system C is relatively unaffected by catalyst loading, suggesting that this commercial resin is already highly catalyzed. A more pronounced effect is evident in resin D where chemical resistance is improved to the test limit of 200 double rubs with 0.3 and 0.5% catalyst but drops off at 0.6% while impact values simultaneously increase to the test limit of 160 in-lbs. A tradeoff in chemical resistance and impact is not unusual, but it is surprising that this occurs at higher catalyst loadings. Normally, increasing crosslink density improves chemical resistance and penalizes impact resistance. Partial reaction during processing could lead to gel particles and heterogeneous crosslinking of the coating film. This might explain the reduced solvent resistance and improved impact results at the highest catalyst loadings.

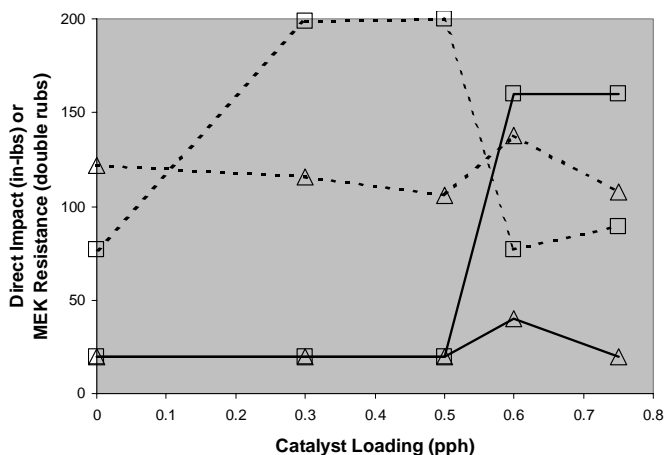

Figure 2.4 Direct impact (solid lines) and chemical resistance (dashed lines) versus catalyst loading in resin systems C (triangles) and D (squares) using zinc phosphate corrosion inhibitor.

Catalyst Type

To this point, only choline chloride has been considered as the added catalyst in coating formulations. Many other candidates exist for the acid/epoxy reaction and several of these have been screened in our laboratory specifically for rapid cure kinetics at 120 °C, latency at 93 °C melt processing, and minimal yellowing under 160 °C over bake conditions. In addition to the choline chloride, our work has identified promise in two benzyltrimethylammonium salts based on either bromide (BTMA-Br) or chloride (BTMA-Cl) counter ions.

As an extension to the present study, BTMA-Br and BTMA-Cl along with choline chloride were screened in formulations based on resin D with either zinc phosphate or barium metaborate corrosion inhibitors. Two catalyst levels were considered, 0.5 and 0.75%. These levels were chosen to capture the low and high extremes of the potential formulation space. In a first pass at the formulation design, a higher catalyst level of 1.0% was selected but screening tests found gel formation during extrusion and so the level was lowered to 0.75%. The performance of coatings prepared in this study is summarized in Table 2.5 with shading again used to denote below target performance.

Table 2.5 Catalyst screening study

Test	Resin D											
	Zinc Phosphate						Barium Metaborate					
	BTMA-Cl		BTMA-Br		C.Chloride		BTMA-Cl		BTMA-Br		C.Chloride	
	Low	High	Low	High	Low	High	Low	High	Low	High	Low	High
Adhesion	4B	4B	4B	4B	4B	4B	4B	4B	4B	4B	4B	4B
Flexibility	N.F.	N.F.	N.F.	N.F.	N.F.	N.F.	N.F.	N.F.	N.F.	N.F.	N.F.	N.F.
Toughness	<20	120	60	160	160	40	60	140	160	40	80	130
Hardness	2H	2H	2H	3H	2H	2H	2H	2H	3H	3H	2H	H
Chem Resist.	107	94	54	54	24	31	84	53	61	27	34	20
60° Gloss	46	27	36	29	40	50	27	16	26	26	61	37
Surface Quality	2	3	2	3	3	4	3	2	2	3	4	3

Catalysts: benzyltrimethylammonium chloride (BTMA-Cl) and bromide (BTMA-Br), Choline Chloride

Catalyst Levels: Low = 0.5, High = 0.75 pph

N.F. = No Failure

Shaded responses indicate failure relative to performance requirements

Relative to non-catalyzed controls (blends D-1 and D-4 in Table 2.4), good flexibility and hardness are generally realized across the formulations summarized in Table 2.5, and in several formulations considerable improvements in toughness are made. At the same time, gloss, surface quality, and chemical resistance are compromised; the effect is more significant in the most highly catalyzed formulations. The limited exceptions are the combinations of zinc phosphate and BTMA-Cl which show slightly enhanced chemical resistance. In 4 of the 6 formulations, the higher catalyst level actually caused a reduction in DSC measured heat of reaction at 120 °C in 30min. Pre-reaction during melt compounding is the most probable cause.

The Table 2.5 formulations based on low-level (0.5%) choline chloride with either corrosion inhibitor represent formulation replicates of chemistries studied in the resin screening study, specifically formulations D-3 and D-6 in Table 2.4. Similarly, an analogue to the high-level (0.75%) choline chloride with zinc phosphate formulation in Table 2.5 was previously examined above in the increased catalyst study. Even though the noted formulations are the same, processing changes were made between the earlier and later studies. Specifically, hand mixing of components was used in the resin screening and increased catalyst work whereas more intense machine (Henschel) mixing was used in the catalyst screening study. Comparing 0.5% analogue formulations, the more aggressively mixed versions show significant improvements in impact resistance and simultaneous reductions in chemical resistance. This is similar to the effect observed

in Figure 2.4 with an increase in the catalyst loading to the highest levels. It is reasonable to suspect that improved reagent mixing increased reagent homogeneity and thereby catalyst efficiency. Further building in this direction, a comparison of 0.75% analogues reveals a precipitous drop in both toughness and chemical resistance in the more intensely mixed catalyst screening formulation. This suggests an upper limit where over catalysis is systemically detrimental. Even below this limit, the lack of processing robustness of highly catalyzed formulations may challenge their viability.

Conclusions

As a benchmark for this research, several commercial low temperature cure powder coatings including candidates representative of all the major coating chemistries were sampled and tested. The results highlight tradeoffs that challenge the ability to achieve desired coating performance in a low temperature cure powder coating. With these materials as reference, experimental low temperature cure powder coatings built on commercial acid functional polyester resins with TGIC crosslinker were formulated and studied. Despite similar functional densities, base resin selection had a significant influence on coating performance but with corrosion inhibitor type, catalyst type, and catalyst loading all having strong and sometimes confounded interactions. For instance, the effect of corrosion inhibitor type was found to depend on both the base resin and added catalyst type as well as catalyst level. The corrosion inhibitors themselves appeared to dually act as catalysts for the epoxy/acid reaction. Their effect was difficult to predict, however, complicated in part by the localized surface effects of heterogeneous catalysis.

The best overall coating performance was realized in formulations with heavily pre-catalyzed resins. Even with these resins additional catalysis was required to attain adequate network formation for good coating flexibility, hardness, and chemical resistance in a 120 °C cure. Further increases in catalyst level or more aggressive reagent mixing produced a limited window of dramatically improved impact resistance but with a concomitant drop in chemical resistance. These coatings may have been effectively impact-toughened by heterogeneous network formation or, possibly, the higher levels of catalysis may have supported epoxy/epoxy reaction of crosslinker moieties and thereby produced a more chain extended network. At the highest extreme of catalyst loading investigated, gelation during melt extrusion and/or systemic degradation of coating performance became prohibitive.

Overall, progress was made toward closing identified performance gaps for 120 °C - 30 min. cure powder coatings but further improvements are needed. This study sets a foundation for subsequent developments in new low temperature cure resins, catalysts, and formulation technologies. Future work will also more closely consider the processing window of highly catalyzed systems and will utilize more rapid extrudate cooling methodologies representative of commercial powder coating production.

Acknowledgements

The authors thank Douglas S. Richart for his consultation on low temperature powder coating developments. This research was supported in part by the U.S. Department of

Defense Contract DACA72-02-C-0025, through the Strategic Environmental Research and Development Program (SERDP), Pollution Prevention Program Manager Chuck Pellerin.

References

1. Miller, E. P.; Taft, D. D. *Fundamentals of Powder Coating*; Society of Manufacturing Engineers: Dearborne, MI, **1974**.
2. Misev, T. A. *Powder Coatings: Chemistry and Technology*; John Wiley & Sons: New York, **1991**.
3. Richart, D. S. *Coating Processes (Powder Technology)*; Howe-Grant, M., Ed.; John Wiley & Sons, Inc.: New York, **1993**; Vol. 6, pp 635-661.
4. Misev, T. A.; van der Linde, R. *Prog. Org. Coat.* **1998**, *34*, 160-168.
5. Farrel, R. *Metal Finishing* **2000**, *98*, 135-141.
6. Armstrong, B. *Powder Coating* **2002**, *Sep*, 60-61.
7. Bergmans, A.; DeCock, C.; Bertens, J.; Kooijmans, P., Shell International Research, *Acid Functional Polyester Resins and Lower Temperature Curable Powder Coating Compositions Comprising Them*, **2000**; European EP 1,006,163.
8. Bergmans, A.; Walravens, M.; DeCock, C.; Riviere, J. *Polymers Paint Colour Journal* **2001**, *Oct*, 17-19.
9. Danick, C. *Low Temperature Crosslinking for Powder Coatings*; Federation of Societies for Coatings Technology International Coatings Conference, New Orleans, LA, **1998**.
10. Johansson, M.; Malmstrom, E.; Jansson, A. *J. Coat. Techn.* **2000**, *72*, 49-54.
11. Laas, H. J.; Meier-Westhues, H. U.; Halpaap, R.; Freudenberg, U.; Klee, H. P., Bayer, *Polyurethane Powder Coating Compositions Which Have a Low Stoving Temperature*, **1998**; U.S. 5,847,044.
12. Malmstrom, E.; Johansson, M.; Jansson, A.; Hult, A. *Novel Concept for Low Temperature Curing Powder Coatings Based on Hyperbranched Polymers*; Proceedings of the International Waterborne, High Solids and Powder Coatings Symposium, New Orleans, LA, **1999**, pp 373-382.
13. McBride, P. J. *J. Oil. Col. Chem. Assoc.* **1982**, *65*, 257-262.
14. Pappas, S. P.; Hill, L. W. *J. Coat. Techn.* **1981**, *53*, 43-50.
15. Pont, J. D. *Further Advances in Low Temperature Cure Polyurethane Powder Coatings*; Proceedings of the International Waterborne, High Solids and Powder Coatings Symposium, New Orleans, LA, **1999**, pp 232-245.
16. Rijkse, K. *Modern Paint & Coatings* **2001**, *April*, 36-39.
17. Roescher, A.; DeRuiter, B. *New Isocyanate-Based Low-Temperature Hardeners for Powder Coatings*; Proceedings XXV FATIPEC Congress, Torino, Italy, **2000**, pp 175-190.
18. Ruth, W. G.; Greth, S. L.; Seelig, C. A.; Schreffler, D. A., Morton International Inc., *Powder Coating of Non-Crystalline and Crystalline Epoxy Resins*, **2000**; U.S. 6,140,430.
19. Sohoni, M.; Figlioti, P. *Developments in Low Temperature Cure: Urethane Powder Curing Agents*; Proceedings of the International Waterborne, High Solids and Powder Coatings Symposium, New Orleans, LA, **1998**, pp 267-280.

20. Subramanian, R.; Sullivan, C. J. *Unsaturated Polyesters in Low Temperature Cure Powder Coatings*; Proceedings of the International Waterborne, High solids and Powder Coatings Symposium, New Orleans, LA, **2001**, pp 381-389.
21. Wenning, A.; Franzmann, G.; Spyrou, E., Degussa AG, *Powder Coating Compositions Comprising Crystalline Urethane Acrylates and Use Thereof*, **2003**; US 0175433 A1.
22. Witzeman, J. S. *Prog. Org. Coat.* **1996**, *27*, 269-276.
23. Wicks, Z. W.; Jones, F. N.; Pappas, S. P. *Organic Coatings: Science and Technology*; 2nd ed.; Wiley-Interscience: New York, **1999**.
24. Wicks, D. A.; Wicks, Z. W. *Prog. Org. Coat.* **1999**, *36*, 148-172.
25. Wicks, D. A.; Wicks, Z. W. *Prog. Org. Coat.* **2001**, *41*, 1-83.
26. *Epoxy Resins: Chemistry and Technolgy*; May, C. A., Ed.; Marcel Dekker Inc.: New York, **1988**.

Chapter 3: Acid/Epoxy Reaction Catalyst Screening for Low Temperature (120 °C) Powder Coatings

Abstract

A review and experimental assessment of commercially viable crosslinking reaction schemes was used to down select the acid/epoxy reaction as the most promising route to low temperature curing (≤ 120 °C) powder coatings. This paper describes efforts to identify and screen suitable acid/epoxy reaction catalysts including tertiary amines, ammonium compounds, and metal complexes. Thermal analysis techniques were developed to aid evaluation of catalyst efficacy and a statistical design of experiments was carried out to study several commercially available catalysts. In three different resin/crosslinker systems, the effect of catalyst type and loading were assessed and ranked in terms of kinetic responses including reaction rate, total heat-of-reaction, and extent-of-conversion. Isothermal kinetics modeling was also used to predict and compare reaction rates over a range of temperatures. Additionally, the susceptibility of each catalyzed system to thermal yellowing upon over-bake was evaluated.

Introduction

Over the past years powder coatings have increasingly gained popularity as a result of their ecological, economical and performance benefits¹⁻⁶. As a result of the relatively high curing temperatures, typically in the range of 150-200 °C, powder coatings are limited to substrates that can tolerate high temperatures. Even with advances that reduce cure temperatures to as low as 130 °C, most powder coating systems still cure at temperatures that are significantly higher than those associated with conventional solvent or water-borne coatings. To make substrates such as plastics, wood, and certain metal alloys accessible to powder coatings, it is necessary to further lower curing temperatures. Such advancements could also translate into energy savings or higher productivities in industrial coating lines⁷.

However, obtaining high reactivity and conversion as well as good flow and leveling at lower temperature remains the largest obstacle for low temperature curing powder coatings^{8,9}. Depending on the coating chemistries, solutions have been offered in the literature^{7,10-14} for some of these challenges. A range of new blocking groups for isocyanates has been introduced¹⁵⁻²³ that allow a significant reduction in curing temperatures compared with conventional blocked isocyanates. Furthermore, optimizing the polyalcohol reaction partner yields systems¹⁶ which are reported to cure reliably and show good leveling as low as 130 °C.

For epoxy chemistries catalysts have been proposed²⁴⁻²⁶ that are highly active at the desired curing temperatures, yet still allow melt processing of the powder coatings at slightly lower temperatures. Furthermore, special binders and co-resins have been developed²⁷⁻³⁰ which show a much more rapid drop in viscosity as a result of the incorporation of crystalline and hyperbranched structures. In combination with UV

crosslinkable moieties^{27,28,31} this approach has yielded powder coatings that may be wholly or partially radiation cured at temperatures lower than 130 °C. However, UV curing is often limited to planar substrates or substrates with simple geometries. Complex three-dimensional objects are still very difficult to cure reliably and evenly by UV exposure.

Therefore, a thermally curing powder coating that melts, flows, and cures (chemically crosslinks) at low temperatures and in a reasonable time frame has much commercial relevance, especially as the range of applications of powder coatings expands to non-metal substrates. In this paper the choice and amount of catalyst used in acid/epoxy powder coating systems has been examined in order to optimize for low temperature cure. In particular the cure kinetics as well as the discoloration effects of over-bake have been investigated for a variety of different commercially available acid/epoxy catalysts.

Experimental

Materials

The materials used in this study were used as received from their manufacturers. Molecular weights and/or equivalent weights used to formulate the coatings were taken from technical data sheets or certificates of analysis. When an equivalent weight range was reported a midpoint value was used in calculations. For catalyzed formulations more care was given to insure exact stoichiometry. To this end, phosphorus 31 NMR was used to precisely determine the acid functionality of Rucote 921, Crylcoat 7309, and Albester 5160³². Tables 3.1 and 3.2 are complete lists of the resins, crosslinkers, and catalysts used in this study. Catalyst loading levels were calculated on a molar equivalent basis to compensate for the different molecular weight of the catalysts. The catalyst loadings levels are reported in mole percent with respect to the reactive functionalities.

Table 3.1 Resins and crosslinkers

Material Type	Product	Manufacturer	Equivalent Wt
Acid Polyester	Rucote 921	Bayer	1631
Acid Polyester	Rucote GXP 9005 n.c.*	Bayer	1438
Acid Polyester	Rucote GXP 9005	Bayer	1446
Acid Polyester	Crylcoat 7206	UCB	821
Acid Polyester	Crylcoat 7309	UCB	1876
Acid Polyester	Albester 5160	Eastman	1876
Acid Polyester	Albester 5180	Eastman	1726
Acid Polyester	Albester 5190	Eastman	1726
Hydroxyl Polyester	Rucote 194	Bayer	1247
Hydroxyl Polyester	Crylcoat 290	UCB	1721
Hydroxyl Polyester	Crylcoat 291	UCB	1827
Epoxy Resin	Epon 2002	Resolution	718
Anhydride Resin	Additol VXL 1381	Solutia	181
Glycidyl Methacrylate	FC A-229-30-A	Reichhold	519
Phenolic Hardener	DEH 82	Dow	250
Triglycidyl Isocyanurate	TEPIC-G	Nissan	105
Blocked Isocyanate	Creilan VP LS 2256	Bayer	280
Uretidione	Creilan TP LS 2147	Bayer	310

*n.c. denotes a non-catalyzed variant of Rucote GXP 9005

Table 3.2 Catalysts

Catalysts	Manufacturer	MW/Metal %
Benzyltrimethylammonium bromide	Aldrich	230
Benzyltrimethylammonium chloride	Aldrich	185
Zinc Acetate	Aldrich	183/36%
Zinc Acetylacetonate Hydrate	Aldrich	263/25%
Nacure XC-B219	King Industries	Unknown/9.5%
Nacure Super XC-7231	King Industries	Unknown
2-Methylimidazole	BASF	82
Actiron CC6 (Choline Chloride)	Synthron	139

Formulation Methods

Dry-blending or melt-mixing methods were used to prepare formulations. For dry-blending, resin-crosslinker combinations were cooled in liquid nitrogen before grinding a hammer mill (Brinkman Instruments Retsch Grinding Mill 2716-00). For melt-mixing, formulations (resin, crosslinker, and catalyst) were pre-mixed in a coffee grinder and then melt-compounded in a 16 mm twin-screw extruder (Prism, L/D = 25) at 85 °C to 95 °C. Upon exiting the extruder die, the material was quenched in liquid nitrogen. The extrudate was then ground and dried under vacuum at room temperature.

Reaction Kinetics

Samples, 15-20 mg in size, were analyzed using a Perkin Elmer DSC 7. Two isothermal testing protocols were used. The first utilized an isothermal hold at 120 °C for 30 minutes followed by a rapid quench and then a temperature scan from 25-300 °C at 10 °C/minute. Heat of reaction and the corresponding cured powder percent conversion curve were obtained from the isothermal portion of the test while the cured network T_g and residual heats of reaction were assessed from the follow-up scan. Both heats of reaction were used to calculate the actual percent conversion at 120 °C in 30 minutes and the slope of the reaction onset was used to calculate the initial reaction rate.

The second DSC test protocol consisted of testing a given formulation isothermally at four different temperatures (120, 125, 130, and 135 °C) for reaction times up to 60 minutes. For formulations with out catalyst, a higher temperature range (135 to 150 °C) was used to ensure complete cure. With the collected data, nth order reaction kinetic parameters were obtained using Pyris kinetics software. The parameters were used in the kinetic models to predict reaction rate as a function of temperature³³⁻³⁷.

To evaluate DSC measurement error, a selected formulation was produced six times and subjected to replicate testing at a cure condition of 120 °C for 30 min. Table 3.3 shows the measured mean, standard deviation, and calculated 95% confidence interval for the six replicates. To provide perspective on the size of the 95% confidence intervals, each interval was normalized as a percentage of its respective mean response value with the results listed in the last row of Table 3.3. All the responses show tight confidence intervals of between 3 to 7%.

Table 3.3 DSC Measurement statistics for replicate testing at 120°C – 30 min

	dx/dt	Heat of Rxn	Conv.	Tg
	1/min	J/g	%	°C
Mean	0.063	21.8	73.0	65.0
Standard Dev	0.003	0.5	2.4	1.1
95% Conf. (+/-)	0.002	0.4	2.0	0.9
Mean Normalized 95% Conf. (%)	7.1	3.5	5.2	2.8

Over-Bake

Catalyzed formulations were prepared into 40 mg pellets using a 1.2 cm diameter pill press. A Universal Film Maker (Spectra-Tech) was then used to melt each pellet into a uniform uncured film. For this, the dry pellet was sandwiched between a glass slide and Teflon[®] and melted at 67 °C in the film-maker. Each film was then cured on the glass slide at 160 °C for 30 minutes and analyzed for the yellowness index (YI) with a colorimeter (Macbeth Color-Eye 7000A)³⁸.

Seven replicates of a selected formulation were prepared, cured, and tested to estimate error. With a mean YI of 1.25, a sample standard deviation of 0.13 was measured. The 95% confidence interval for this measurement is 15% of the mean value. For these samples, the film thickness was on average 462 μm with a standard deviation of 69 μm; this thickness variation is not believed to have contributed significantly to YI measurements. As reference, the YI of the glass slide substrates was measured to be 0.21 with a standard deviation of 0.01.

Accelerated Aging

Selected powders were thermally aged in a convection oven at 48 °C for approximately two weeks. On a regular basis the powders were visually evaluated for sintering and their gel times measured at 180 °C following the Powder Coating Institute (PCI) and ASTM test protocol³⁹.

Results and Discussion

Reaction Scheme Assessment

Four major crosslinking chemistries used conventionally in thermally cured powder coatings are shown in Figure 3.1. For each system, examples of resin, crosslinker, and catalyst types are provided. The reaction schemes are arranged left to right in order of increasing opportunity for low temperature cure. This is based on the low end of the temperature use-range shown under each chemistry. Leftmost and least reactive is the acid/hydroxyl reaction. Its low temperature use is limited by the nature of the esterification reaction and the need to drive off water to obtain high conversions. This scheme is used in Primid[®] polyesters. Slightly lower temperatures can be used to cure hydroxyl resins with protected or dimerized isocyanates to yield polyurethane coatings. However, the deblocking temperatures of the protective group or the ring scission kinetics of the uretidione limit the minimum cure temperature to approximately 140 °C. The two remaining reaction types are epoxy based; these have the highest potential for low temperature cure. Epoxies can crosslink with a variety of different chemical

functionalities, such as acids, aromatic hydroxyls, amines, or even through catalyzed homopolymerization. For exterior applications, acid functional polyesters are often combined with multifunctional epoxy crosslinkers. Triglycidylisocyanurate (TGIC) is most commonly used as the epoxy functional crosslinker. Acrylate resins functionalized with epoxy moieties such as glycidyl methacrylate (GMA) are increasingly finding use in exterior applications. However, acrylate resins typically have higher glass transition temperatures and therefore require higher application temperatures. Moreover, owing to limited accessibility of epoxy functionalities distributed along the polymer backbone, high conversions are difficult to obtain. Use of bisphenol-A (BPA) and novolac epoxies is restricted to interior applications because of their poor weathering performance. Some cycloaliphatic epoxies are available that do not suffer from the weathering limitations of aromatic systems, however, the physical form of these resins is unsuitable for use in powder coatings.

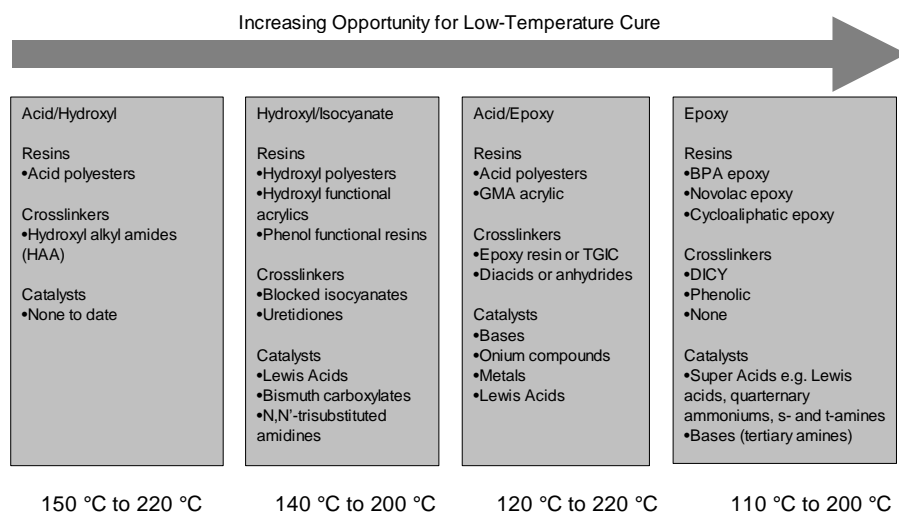

Figure 3.1 Overview of powder coating chemistries and typical temperature ranges for cure. The systems are ranked from left to right in order of increasing opportunity for low temperature cure.

To specifically quantify the ranking depicted in Figure 3.1, several formulations were made and their cure kinetics at 120 °C investigated by thermal analysis. Table 3.4 summarizes the chemistries studied. These include four different acid functional polyesters (acid-PE) crosslinked by a glycidyl methacrylate (GMA), four grades of acid-PE (including one non-catalyzed variant) crosslinked using TGIC, and an anhydride crosslinked GMA. Additionally, three types of urethanes were studied: two based on uretidione with two different hydroxyl functional polyesters (hydroxyl-PE) and one based on a blocked isocyanate (NCO) with a hydroxyl-PE. Finally, a BPA-epoxy with a base catalyzed phenolic crosslinker was investigated as well as epoxy homopolymerization by both acid and base catalysis. All formulations were produced by the dry-mixing method described in the experimental section. Resin and crosslinker formulation weights were adjusted to maintain a 1 to 1 stoichiometric ratio. For the epoxy homopolymerizations, 0.6 % by weight of either an acid or base catalyst was added.

Table 3.4 Commercial resin /crosslinker formulations.

Chemistry	Formulations			
	Component 1	Wt	Component 2	Wt
acid-PE / GMA	Rucote GXP 9005	73.5	FC A-229-30-A	26.5
acid-PE / GMA	Rucote 921	74.0	FC A-229-30-A	26.0
acid-PE / GMA	Albester 5180	76.9	FC A-229-30-A	23.1
acid-PE / GMA	Albester 5190	76.9	FC A-229-30-A	23.1
acid-PE / TGIC	Albester 5180	94.3	TEPIC-G	5.7
acid-PE / TGIC	Albester 5190	94.3	TEPIC-G	5.7
acid-PE / TGIC	Rucote GXP 9005	93.3	TEPIC-G	6.7
acid-PE / TGIC Non-Catalyzed	Rucote GXP 9005 n.c.	93.2	TEPIC-G	6.8
GMA / Anhydride	FC A-229-30-A	74.2	Additol VXL 1381	25.8
hydroxyl-PE / Uretidione	Crylcoat 290	84.7	Crelan TP LS 2147	15.3
hydroxyl-PE / Uretidione	Crylcoat 291	85.5	Crelan TP LS 2147	14.5
hydroxyl-PE / blocked-NCO	Rucote 194	81.6	Crelan VP LS 2256	18.4
Epoxy / Phenolic*	Epon 2002	74.2	DEH 82	25.8
Epoxy Base-Catalyzed	Epon 2002	99.4	2-methylimidazole	0.6
Epoxy Acid-Catalyzed	Epon 2002	99.4	Nacur Super XC-7231	0.6

*phenolic crosslinker precatylyzed with 2-methylimidazole

Figure 3.2 shows a plot of reaction conversion versus time at 120 °C obtained from DSC measurements. To simplify graphical analysis only one representative sample is included in the figure for each of the chemistry types. The results strongly differentiate the low temperature cure potential for the various chemistries. Consistent with Figure 1 and the preceding discussion, highest levels of conversion, 95% and greater, were achieved with epoxy-based reaction schemes within 30 min. at 120 °C. However, the acid catalyzed epoxy reaction and the non-catalyzed acid-PE / TGIC reaction proved to be one of the least reactive systems under test conditions. This result highlights the importance of catalysis to enable low temperature crosslinking reaction. Urethane chemistries and reactions with GMA resins showed limited potential at 120 °C. As discussed earlier, the Arrhenius temperature dependence of deblocking, ring scission, and molecular mobility significantly hinders the low temperature reactions of blocked-NCO, uretidione, and GMA systems, respectively.

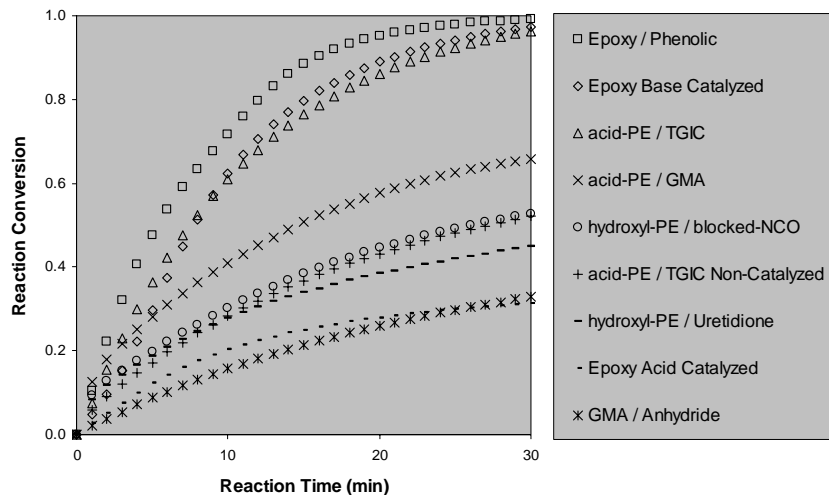

Figure 3.2 DSC measured reaction conversion versus time at 120 °C for selected resin/crosslinker formulations.

Although epoxy homopolymerization and epoxy crosslinking with a base catalyzed phenolic are among the best low temperature reaction schemes in this study, the epoxy resins commercially available lack the resistance to ultraviolet light required for exterior applications. To meet both exterior durability as well as low temperature cure requirements, formulations based on catalyzed acid functional polyesters and epoxy crosslinkers offer the best prospect. Despite concerns about the potential toxicity of TGIC crosslinker, there are no commercial alternatives that offer similar performance. Therefore, the remainder of this study will focus on acid-PE / TGIC reaction systems and the identification of suitable low temperature catalysts based on screening for 120 °C reaction kinetics, processing temperature latency, and resistance to yellowing upon over-bake.

Acid-Epoxy Catalyst Selection

A wide variety of different catalysts for acid-epoxy reactions are discussed in the literature^{24,26,40-42}. Very broadly, these catalysts can be categorized into four classes: bases (mainly nitrogen based), onium compounds, metals, and cationic species. Examples from each of these classes are listed in Figure 3.3. The application and the performance requirements tend to dictate catalyst suitability. For the present study, only commercially available catalysts are considered, and, in addition to low temperature reactivity, the down-selection criteria include powder coating requirements for toxicity, handleability, physical form, scalability, and economy.

Bases such as tertiary amines and nitrogen heterocycles are commonly used in applications that are not sensitive to discoloration or yellowing. This catalyst class tends to provide high reactivity at relatively low cost. Furthermore, there is a large commercial pool of materials that can be employed. However, as a result of their volatility, yellowing, odor, and hazard labeling these catalysts might not be suitable for all applications. 2-methylimidazole (2-MI) was chosen from this group for further investigation as it displays high reactivity, yet has a relatively low odor and is a solid at room temperature.

Of the onium catalysts, phosphonium and ammonium halides are the most commonly used for epoxy reactions. Representative examples from the large variety of commercially available onium salts are shown in Figure 3.3. These catalysts offer very high activity even at room temperature while also showing less thermal yellowing than amines. In addition to choline chloride (CC), which is a benchmark for catalysts in epoxy powder coats, the two benzyltrimethylammonium salts (BTMA-Br and BTMA-Cl) were down selected.

A large number of diverse metal salts & chelates have been tested in epoxy formulations and many different systems are employed in commercial applications. These metal salts are often stable at much higher temperatures and are, therefore, better suited for high temperature curing powder coatings. Furthermore, metal salts can show very low yellowing during cure and through the life of the coating compared with the previous two catalyst classes. Zinc catalysts are frequently used, especially in corrosion inhibiting

coatings, to attain high conversions and thus good chemical resistance⁴². Consequently, three representative zinc compounds were chosen to represent this catalyst class in further studies: zinc (2)-acetylacetonate hydrate (zinc acac), zinc acetate, and a proprietary zinc complex.

Cationic species include conventional acids as well as Lewis acids. Although these compounds tend to be very good catalysts for epoxy-homopolymerization, they often lead to side reactions in acid/epoxy systems⁴². As a result of their aggressive and corrosive nature, handling of these chemicals requires precaution and special equipment. Most of the Lewis acids are very sensitive to moisture that can liberate strong acids. Careful control of the storage atmosphere and the curing process is therefore required. For these reasons, Lewis acids are not commonly employed in acid/epoxy coating systems, and cationic systems altogether were omitted from this catalyst study.

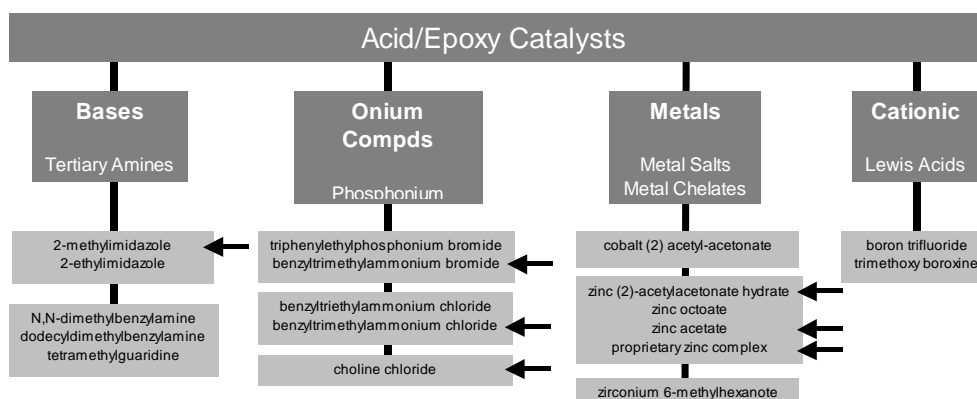

Figure 3.3 Representative candidate acid-epoxy reaction catalysts. Four categories of compounds are considered with examples in each class. Arrows indicate catalysts down selected in this work for screening studies.

Catalyst Screening

A general factorial screening experiment was conducted to investigate the seven down-selected catalysts. Each catalyst was studied at two levels, 2 and 5 mole percent relative to the resin acid functionality, in three different resin systems. Since molecular weight information was unavailable for the King Industries proprietary zinc complex XC-B219 it was formulated at an equivalent metal content relative to the other zinc containing catalysts. The three acid functional polyester resins studied were Rucote 921, Crylcoat 7309, and Albester 5160. All resins were formulated 93/7 PE/TGIC by weight. As controls, non-catalyzed formulations for each base resin were investigated, and to enable statistical assessment of error a selected formulation (Albester 5160 with 5% choline chloride) was replicated 5 times. The formulation matrices for each resin system are provided in Tables 3.5 and 3.6. Since Crylcoat 7309 and Albester 5160 share the same equivalent molecular weight their formulations are the same. Mixing of all the 100 g batch size formulations was done by melt compounding in an extruder.

Table 3.5 Rucote 921 formulations

	Control	Low	High	Low	High	Low	High	Low	High	Low	High	Low	High	Low	High
Rucote 921	93.00	92.92	92.79	92.85	92.63	92.81	92.51	92.81	92.52	92.72	92.31	92.76	92.39	92.27	91.21
TGIC	7.00	6.99	6.98	6.99	6.97	6.99	6.96	6.99	6.96	6.98	6.95	6.98	6.95	6.95	6.87
2-MI	***	0.09	0.23	***	***	***	***	***	***	***	***	***	***	***	***
choline chloride	***	***	***	0.16	0.40	***	***	***	***	***	***	***	***	***	***
benzyltrimethylammonium chloride	***	***	***	***	***	0.21	0.53	***	***	***	***	***	***	***	***
zinc acetate	***	***	***	***	***	***	***	0.21	0.52	***	***	***	***	***	***
zinc (2) acetylacetonate hydrate	***	***	***	***	***	***	***	***	***	0.30	0.75	***	***	***	***
benzyltrimethylammonium bromide	***	***	***	***	***	***	***	***	***	***	***	0.26	0.65	***	***
Nacure XC B219	***	***	***	***	***	***	***	***	***	***	***	***	***	0.78	1.92
Total	100	100	100	100	100	100	100	100	100	100	100	100	100	100	100

Table 3.6 Crylcoat 7309 and Albester 5160 formulations

	Control	Low	High	Low	High	Low	High	Low	High	Low	High	Low	High	Low	High
Crylcoat 7309 or Albester 5160	93.00	92.93	92.81	92.87	92.68	92.83	92.57	92.83	92.58	92.76	92.40	92.79	92.47	92.37	91.45
TGIC	7.00	6.99	6.99	6.99	6.98	6.99	6.97	6.99	6.97	6.98	6.95	6.98	6.96	6.95	6.88
2-MI	***	0.08	0.20	***	***	***	***	***	***	***	***	***	***	***	***
choline chloride	***	***	***	0.14	0.34	***	***	***	***	***	***	***	***	***	***
benzyltrimethylammonium chloride	***	***	***	***	***	0.18	0.46	***	***	***	***	***	***	***	***
zinc acetate	***	***	***	***	***	***	***	0.18	0.45	***	***	***	***	***	***
zinc (2) acetylacetonate hydrate	***	***	***	***	***	***	***	***	***	0.26	0.65	***	***	***	***
benzyltrimethylammonium bromide	***	***	***	***	***	***	***	***	***	***	***	0.23	0.57	***	***
Nacure XC B219	***	***	***	***	***	***	***	***	***	***	***	***	***	0.68	1.66
Total	100	100	100	100	100	100	100	100	100	100	100	100	100	100	100

Thermal Analysis

In the coatings industry, applied methods such as the methylethylketone (MEK) double-rub test are often used to assess degree of cure. For the present work, a more analytical method of evaluating reaction kinetics is desired. DSC provides this information in the form of a quantitative measure of the heat of reaction. As a characterization technique, DSC is particularly valuable for high throughput screening of the more than 50 laboratory-scale samples studied in this work. Using the methods described in the experimental section, initial reaction-rate, heat-of-reaction, and extent-of-conversion were determined for samples subjected to a 30 min. cure at 120 °C. Figure 3.4 shows the compiled DSC responses for all seven catalysts in the three different resin systems as a function of the mole percent catalyst loading. Similar trends in catalyst efficiency are interpreted from analysis of each of the responses reported. Therefore, for the sake of conciseness much of the discussion to follow emphasizes the initial reaction-rate results.

The initial rate of reaction is notably different for the three uncatalyzed resin systems. In order of increasing rate the resins rank as follows: Albester 5160, Crylcoat 7309, and Rucote 921 with corresponding reaction rates of 0.02, 0.05, and 0.13 1/min. The heat-of-reaction and conversion also demonstrate the same trend. This observation is not surprising given resins are commonly pre-catalyzed by their manufacture's. Unfortunately, because of proprietary considerations the manufacturers are typically unwilling to disclose how much and what type of catalysts is used.

Generally, the catalysts added in this study induce similar effects across the three resins. The greatest increase in reaction rate was attained with the use of the four nitrogen based catalysts: 2-methylimidazole, choline chloride, benzyltrimethylammonium bromide and

chloride. The effect was greatest in the least pre-catalyzed resin (Albester 5160) and lesser in the highest (Rucote 921).

For the most part, addition of the metal complexes (zinc acetate, zinc acac, or the proprietary zinc complex) had negligible effect on the reaction rate. The two exceptions were (i) zinc acac in Albester 5160 where a notable increase in reaction rate was observed, and (ii) in Rucote 921 where the zinc complex and zinc acac produced strongly deleterious effects. It is possible that catalysts added by the resin manufacturer unfavorably interact with the metal complexes. This would poison both the manufacture's catalyst as well as the catalyst added in this study. Consistent with this supposition, the addition of metal catalysts most negatively affected the reaction rate of the most highly pre-catalyzed resins (presumed to be Rucote 921 and Crylcoat 7309). On the other hand the Albester resin either does not contain a pre-catalyst or its pre-catalyst does not interact with the metal catalyst, this may explain why this system shows a considerable increase in reaction rate with the addition of zinc acac. It is also possible that higher reaction temperatures may be required to achieve the full catalytic benefits of these zinc catalysts. If so, these catalysts would have little practical utility for the present work.

Although the preceding discussion focused on the rate-of-reaction it is also important to understand the effect of the catalyst on the total realized heat-of-reaction and thus the extent of conversion. High conversions are paramount to complete network formation and optimization of coating properties. In plots of cured coating glass transition versus heat-of-reaction Figure 3.5 illustrates that glass transition is a sensitive indicator of network formation. For reference, resin formulations without added catalyst cured at 120 °C for 30 min have network glass transitions of 67, 64, and 58 °C for Rucote 921, Crylcoat 7309, and Albester 5160, respectively. The strong relationship shown in Figure 3.5 emphasizes the importance of maximizing the conversion to obtain optimal coating properties and, therefore, the significance of choosing the right catalyst.

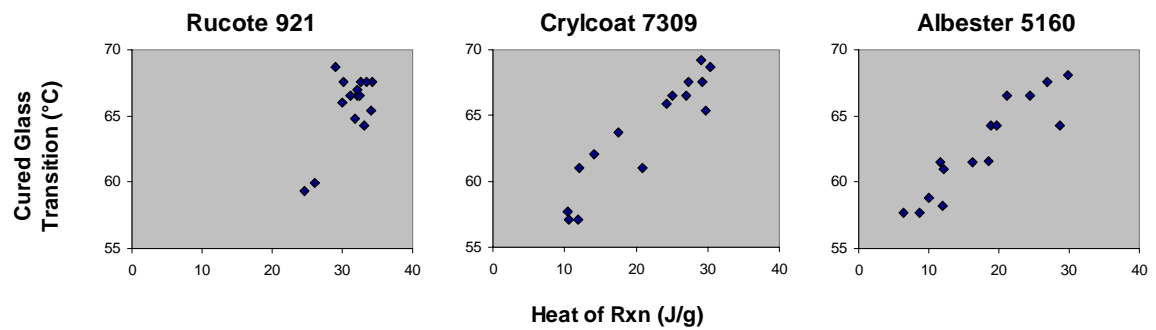
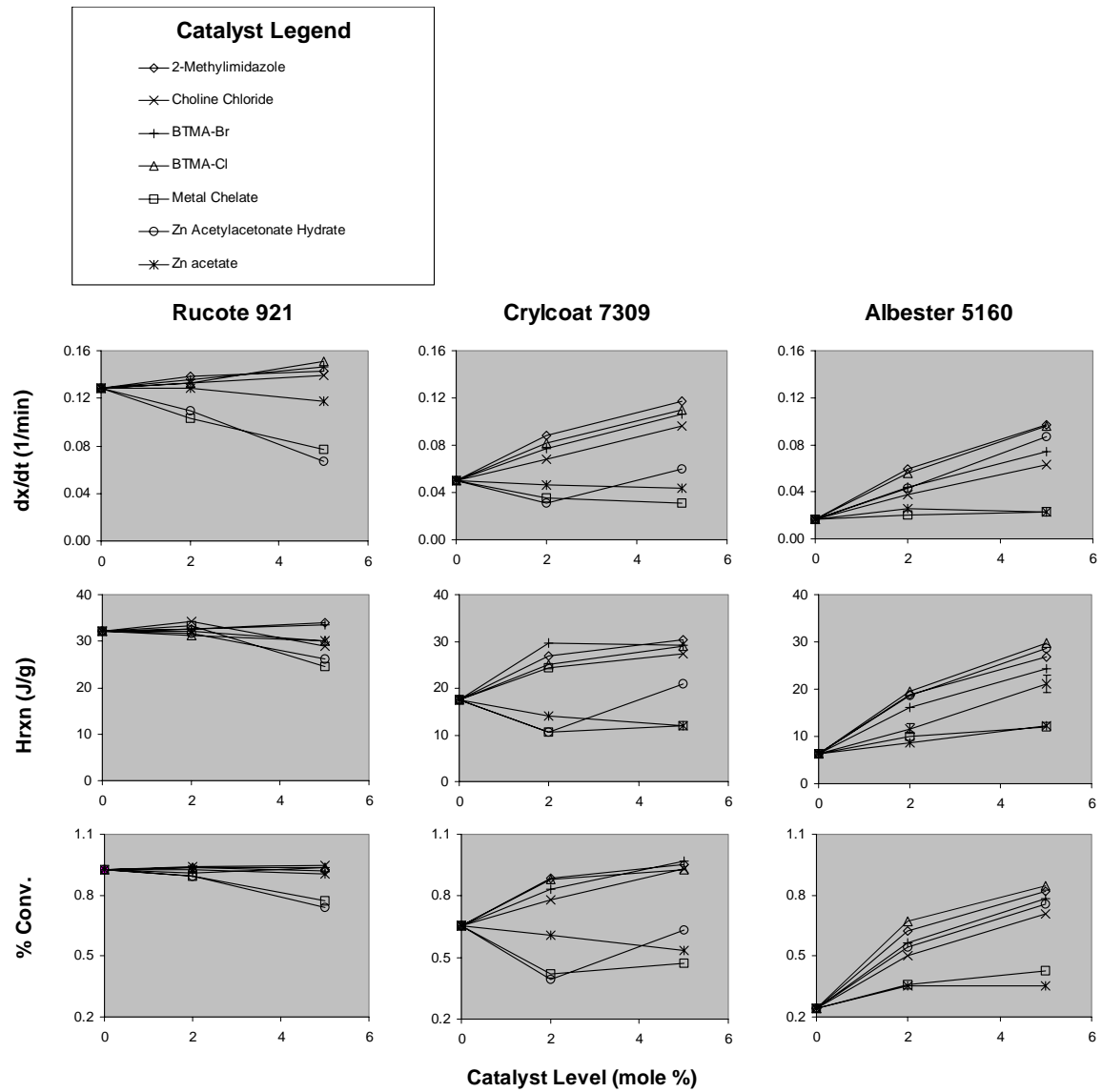

Reaction Latency

While it is desirable to increase reaction rate at cure temperatures it is necessary to avoid pre-reaction during melt extrusion. This is a particular challenge with low temperature curing powder coatings where the compounding and cure temperatures are close together. The low end of this temperature window is set by the need to have a non-sintering, friable powder at room temperature; for this reason, a resin glass transition of about 50 °C is considered a lower limit^{3,43}. In turn, the need to be 30 to 50 °C above the resin glass transition for homogenous extrusion necessitates minimal reactivity at melt processing temps of 80 to 100 °C. Ideally, the crosslinking reaction would be switchable with no reaction at 80 °C and then very rapid reaction at 120 °C. However, the chemistries of interest to the present work do not follow this ideal behavior, instead they follow a classic Arrhenius temperature dependence. For these reasons, the effect of catalyst on the reaction rate is investigated here as a function of temperature.

For this study, Albestor 5160 formulations without catalyst as well as with 5 mole percent of the four nitrogen based catalysts were studied in more detail. Isothermal DSC experiments described in the experimental section were conducted to estimate n^{th} order parameters according to the kinetic model of the form: $d\alpha/dt = Z \cdot \exp(-E_a/RT) (1-\alpha)^n$ where α is conversion, Z is the pre-exponential, n is reaction order, R is the gas constant, and E_a is the activation energy^{35,36}. The parameters determined by this method are reported in Table 3.7. Using these results, the initial reaction rate ($\alpha = 0$) at 120 °C was calculated and compared with experimental measurements. These results are included in Table 3.7. Although the predicted and experimental rates are somewhat different, they are strongly correlated with a linear regression R-squared coefficient⁴⁴ of 97%; thus, the model accurately captures the relative formulation reactivity. Because experimental reaction rates were determined graphically at 2.5 min into the reaction whereas model calculations estimate initial reaction rates ($t = 0$), the difference in the values is not unexpected.

Table 3.7 Kinetic model parameters and reaction rates

	Control	2-MI 5%	CC 5%	BTMA-Cl 5%	BTMA-Br 5%
Z (1/min)	9.9e+3	284.0e+3	6.3e+3	45.4e+6	6.4e+6
Ea (KJ/mol)	40.3	47.7	36.7	64.5	59.2
Reaction Order, n	1.1	1.6	1.1	1.4	1.2
Calc. R(1/min) @ 120 °C	0.029	0.128	0.083	0.121	0.085
Expt. R(1/min) @ 120 °C	0.017	0.097	0.063	0.096	0.074

Applying the n^{th} order reaction model and estimated kinetic parameters the reaction rate was calculated as function of temperature. The predictions are shown in Figure 3.6 for temperatures from 80 to 140 °C. The results indicate that catalyst selection can affect the temperature dependence. This is of particular interest for the two most highly reactive formulations at 120 °C catalyzed with either 2-methylimidazole or benzyltrimethylammonium chloride. Extrapolation down to a melt processing temperature of 80 °C suggests the ammonium chloride to be more latent in reactivity. Overall, the benzyltrimethylammonium halides appear to be more latent than both the imidazole and the choline chloride and, therefore, may be less prone to pre-reaction and gel formation during compounding. These are results of model calculations and still require experimental verification.

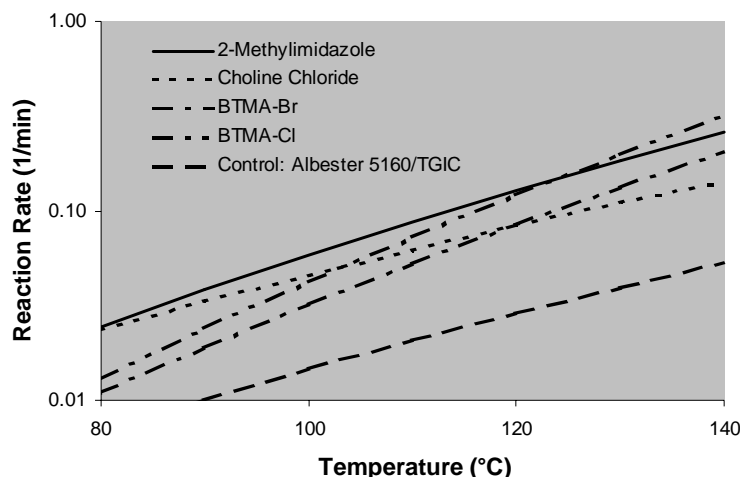

Figure 3.6 Nth order reaction rate model predictions for selected catalyst at 5 mole percent in Albaster 5160 as a function of temperature.

Accelerated Aging

In form and in chemistry, powder coatings should be stable during transportation and storage prior to final application as coatings. To assess these properties accelerated aging tests were performed on selected powders at 48 °C for 13 days and powder sintering and gel times monitored. The same Albaster 5160 formulations used in the preceding section on reaction latency were studied for this work. All formulations including the non-catalyzed control showed slight sintering even after 1 day of aging, however, only slight agitation was required to recover a free flowing powder. This response was consistent throughout the duration of the study and remained unchanged even after several months of continued aging.

Measurements of gel time as a function of accelerated aging are plotted in Figure 3.7. The initial gel times reflect the effects of catalysis relative to the control formulation. All the gel times drop by similar amounts over the course of the first four days before leveling off. DSC measurements on both the control and the BTMA-Cl catalyzed samples show only a slight decrease (~10%) in the heats of reaction after 3 days of aging. Since the change in reactivity is rather small other phenomena might be prevalent. One possibility could be water desorption from the samples. When present, water might solvate the catalyst, thereby reducing its ability to associate with the reactive species. Driving off water under accelerated aging conditions might increase catalyst efficiency, increase the reaction rate, and reduce the gel time. In support of this, sample weight loss of approximately 0.3% was measured after 3 days of aging. Upon re-exposure to ambient conditions for one week a slight increase in sample weight was noted and a small increase in gel time back towards the pre-aged values was measured. The data is admittedly limited at this time and further experiments would be needed to better support this hypothesis.

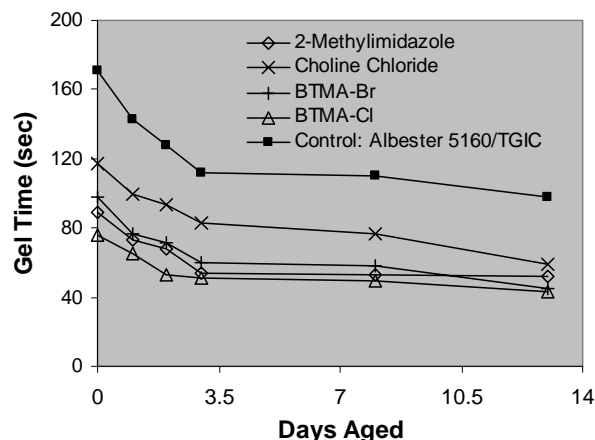

Figure 3.7 Gel time at 180 °C as a function accelerated aging at 48 °C for selected catalysts at 5 mole percent.

Over-bake Yellowing

Coating discoloration as a result of over-bake can be an undesired effect of reaction catalysis. For example, amine catalyzed coatings are known to yellow as a result of exposure to high temperatures^{26,40-42}. It is reasonable to expect low temperature reactions to be less prone to discoloration. However, more catalyst is often required to achieve the low temperature cure, which, in turn, may exacerbate yellowing even at relatively low temperatures. For this reason, the yellowing induced by an over-bake of 30 min at 160 °C was investigated for all of the formulations prepared in the catalyst screening study. The results are summarized in Figure 3.8.

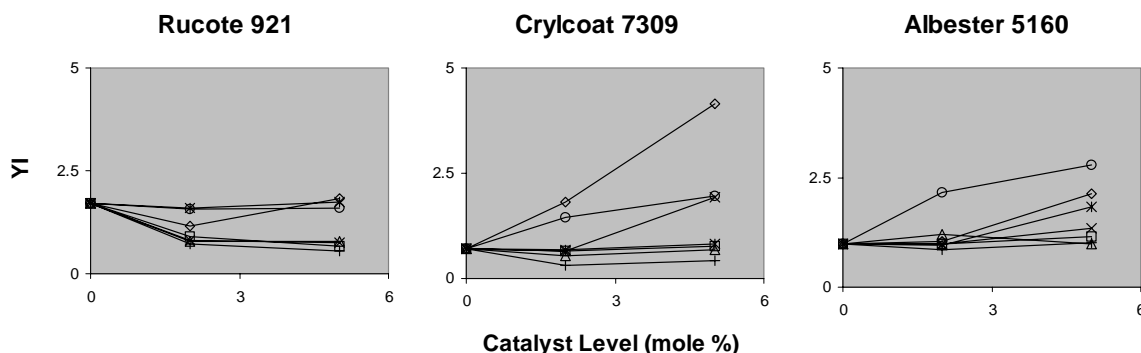

Figure 3.8 Yellowness index (YI) versus catalyst loading for samples subjected to over-bake of 30 min at 160°C. Catalyst legend provided in Figure 3.4.

Depending on loading and the base resin system, the catalyzed systems displayed varying degrees of yellowing. Generally, formulations containing 2-methylimidazole and zinc acac were most susceptible. This was not the case, however, in the highly pre-catalyzed Rucoate 921 where these catalysts had negligible effect; some catalyst even lowered yellowing relative to the control. Consistently, the zinc complex and the two benzyl-trimethylammonium halides showed the least effect on yellowing.

Conclusions

Several different chemistries used in powder coatings were investigated from which the acid/epoxy reaction scheme was down-selected as the most viable for low temperature curing for exterior applications. Seven different catalysts were investigated in three different acid functional polyesters and formulated with TGIC. The catalysts were chosen from the three general families (bases, onium compounds, and metals) and screened at two levels to assess their effects on reaction kinetics and yellowing. Four of the seven catalysts consistently accelerated the kinetics in all three resin systems. These were the three ammonium halides (choline chloride, benzyl-trimethylammonium bromide, and benzyl-trimethylammonium chloride) and 2-methylimidazole. For yellowing upon over-bake at 160 °C, the benzyltrimethylammonium halides consistently showed the least discoloration. Of the four highly active catalysts, modeling of reaction kinetics suggested the benzyltrimethylammonium halides to be the least reactive catalysts under processing conditions (80-90°C). This latency is desirable to avoid gelation during melt extrusion. The two benzyl-trimethylammonium halides showed comparable levels of over-bake yellowing but the chloride variant was found to be more reactive at 120 °C.

In this study, the role of catalyst has been investigated with respect to reaction kinetics and yellowing. Many other performance attributes such as solvent and corrosion resistance as well as weathering must also be considered to ensure the final formulation meets all the demands for a given application. Furthermore, many powder coating formulations contain several additional components not included in this study such as fillers, pigment, and various additives. These components may interact with the catalyst directly or influence other coating properties such as the viscosity of the system, which in turn could influence rate or extent of cure. In this study, these components were omitted in order to simplify the system. Future work will include other responses and complete powder formulations.

Acknowledgements

The authors thank Bayer Corporation, Eastman Chemical, and UCB who kindly helped select the polyester resins used in this work and also provided samples. We also thank Solutia, Nissan Chemical, and Reichhold for providing material samples. We are especially grateful to Werner Blank of King Industries for his consultation on catalyst selection and performance, and Douglas S. Richart for his perspective and insight on powder coating development. This research was supported in part by the U.S. Department of Defense Contract DACA72-02-C-0025, through the Strategic Environmental Research and Development Program (SERDP), Pollution Prevention Program Manager Chuck Pellerin.

References

1. Miller, E. P.; Taft, D. D. *Fundamentals of Powder Coating*; Society of Manufacturing Engineers: Dearborne, MI, **1974**.
2. Misev, T. A. *Powder Coatings: Chemistry and Technology*; John Wiley & Sons: New York, **1991**.
3. Richart, D. S. *Coating Processes (Powder Technology)*; Howe-Grant, M., Ed.; John Wiley & Sons, Inc.: New York, **1993**; Vol. 6, pp 635-661.
4. Misev, T. A.; van der Linde, R. *Prog. Org. Coat.* **1998**, *34*, 160-168.
5. Farrel, R. *Metal Finishing* **2000**, *98*, 135-141.
6. Papasavva, S.; Kia, S.; Claya, J.; Gunther, R. *Prog. Org. Coat.* **2001**, *43*, 193-206.
7. Armstrong, B. *Powder Coating* **2002**, *Sep*, 60-61.
8. Rijkse, K. *Modern Paint & Coatings* **2001**, *April*, 36-39.
9. Rijkse, K. *Metal Finishing* **2001**, *April*, 47-50.
10. Daly, A. T.; Correll, G. D.; Kozlowski, J. J.; Haley, R. P.; Muthiah, J.; Horinka, P. R.; Reinheimer, E. P., Morton International Inc., *Two Component Powder Coating System and Method for Coating Wood Therewith*, **1998**; U.S. 5,714,206.
11. Laas, H. J.; Meier-Westhues, H. U.; Halpaap, R.; Freudenberg, U.; Klee, H. P., Bayer, *Polyurethane Powder Coating Compositions Which Have a Low Stoving Temperature*, **1998**; U.S. 5,847,044.
12. Ruth, W. G.; Greth, S. L.; Seelig, C. A.; Schreffler, D. A., Morton International Inc., *Powder Coating of Non-Crystalline and Crystalline Epoxy Resins*, **2000**; U.S. 6,140,430.
13. Bergmans, A.; DeCock, C.; Bertens, J.; Kooijmans, P., Shell International Research, *Acid Functional Polyester Resins and Lower Temperature Curable Powder Coating Compositions Comprising Them*, **2000**; European EP 1,006,163.
14. Panandiker, K. P.; Bronk, J. M.; Pont, J. D., McWhorter Technologies Inc., *Powder Coatings Based on Branched Oligoesters and Triazole Blocked Polyisocyanates*, **2001**; U.S. 6,248,843.
15. McBride, P. J. *J. Oil. Col. Chem. Assoc.* **1982**, *65*, 257-262.
16. Witzeman, J. S. *Prog. Org. Coat.* **1996**, *27*, 269-276.
17. Sohoni, M.; Figlioti, P. *Developments in Low Temperature Cure: Urethane Powder Curing Agents*; Proceedings of the International Waterborne, High Solids and Powder Coatings Symposium, New Orleans, LA, **1998**, pp 267-280.
18. Danick, C. *Low Temperature Crosslinking for Powder Coatings*; Federation of Societies for Coatings Technology International Coatings Conference, New Orleans, LA, **1998**.
19. Pont, J. D. *Further Advances in Low Temperature Cure Polyurethane Powder Coatings*; Proceedings of the International Waterborne, High Solids and Powder Coatings Symposium, New Orleans, LA, **1999**, pp 232-245.
20. Wicks, D. A.; Wicks, Z. W. *Prog. Org. Coat.* **1999**, *36*, 148-172.
21. Wicks, D. A.; Wicks, Z. W. *Prog. Org. Coat.* **2001**, *41*, 1-83.
22. Roescher, A.; DeRuitter, B. *New Isocyanate-Based Low-Temperature Hardeners for Powder Coatings*; Proceedings XXV FATIPEC Congress, Torino, Italy, **2000**, pp 175-190.

23. Rawlins, J. *New Crosslinkers for Polyurethane Powder Coatings*; Proceedings of the International Waterborne, High Solids and Powder Coatings Symposium, New Orleans, LA, **2002**, pp 357-369.
24. Pappas, S. P.; Hill, L. W. *J. Coat. Techn.* **1981**, 53, 43-50.
25. Danick, C.; Panandiker, K. A. P.; Weidow, T. *Developments in Low Temperature Curing Powder Coatings*; Proceedings of the International Waterborne, High Solids and Powder Coatings Symposium, New Orleans, LA, **1998**.
26. Blank, W. J.; He, Z. A.; Picci, M. *Catalysis of the Epoxy-Carboxyl Reaction*; Proceedings International Waterborne, High Solids and Powder Coatings Symposium, New Orleans, LA, **2001**, pp 297-311.
27. Malmstrom, E.; Johansson, M.; Jansson, A.; Hult, A. *Novel Concept for Low Temperature Curing Powder Coatings Based on Hyperbranched Polymers*; Proceedings of the International Waterborne, High Solids and Powder Coatings Symposium, New Orleans, LA, **1999**, pp 373-382.
28. Johansson, M.; Malmstrom, E.; Jansson, A. *J. Coat. Techn.* **2000**, 72, 49-54.
29. Bergmans, A.; Walravens, M.; DeCock, C.; Riviere, J. *Polymers Paint Colour Journal* **2001**, Oct, 17-19.
30. Wenning, A.; Franzmann, G.; Spyrou, E., Degussa AG, *Powder Coating Compositions Comprising Crystalline Urethane Acrylates and Use Thereof*, **2003**; US 0175433 A1.
31. Subramanian, R.; Sullivan, C. J. *Unsaturated Polyesters in Low Temperature Cure Powder Coatings*; Proceedings of the International Waterborne, High solids and Powder Coatings Symposium, New Orleans, LA, **2001**, pp 381-389.
32. Williams, E. A.; Donahue, P. E.; Early, T. A. GE CR&D Technical Information Series, 2001CRD205.
33. Gherlone, L.; Rossini, T.; Stula, V. *Prog. Org. Coatings* **1998**, 34, 57-63.
34. Belder, E. G.; Rutten, H. J. J.; Perera, D. Y. *Prog. Org. Coatings* **2001**, 42, 142-149.
35. Sichina, W. J. Perkin Elmer Instruments, PETech-48.
36. Goodwin, L.; Lever, T. J. TA Instruments, TA-143A.
37. Korhonen, M.; Starck, P.; Lofgren, B. *J. of Coatings Technology* **2003**, 75, 67-73.
38. ASTM, E 313-96: Standard practice for calculating yellowness and whiteness indices from instrumentally measured color coordinates.
39. ASTM, D 3451: Standardized gel time or stroke cure testing method. Same as PCI standard #6 for Gel Time Reactivity.
40. Blank, W. J. *Macromolecular Symposia* **2002**, 187, 261-270.
41. Blank, W. J. *Journal of Coatings Technology* **2002**, 74, 33-41.
42. Blank, W. J. *Chimia* **2002**, 56, 191-196.
43. Richart, D. *Industrial Paint & Powder R&D Newsletter* **2000**, 2.
44. Weiss, N. *Elementary Statistics: 3rd Edition*; Addison-Wesley Publishing Company, Inc.: New York, **1996**.

Chapter 4: Advancements Toward Low Temperature Curing, 120 °C – 30 min, Powder Coatings for Temperature Sensitive Substrates

Abstract

No commercial powder coatings exist that cure at 120 °C within 30 minutes and meet military requirements for exterior durability, toughness, chemical resistance, gloss, and surface quality. As part of this work, an experimental low temperature cure powder coating has been developed that fulfills all performance requirements for military ground support equipment (Mil-PRF-85285D). Challenges in meeting surface quality while maintain mechanical properties were overcome by key formulation developments in catalyst, resin type, flow additive, particle size, and pigment concentration. Future work will address optimization of the formulations and qualification testing. Incorporation of GE resin has shown capability to improve toughness and chemical resistance requirements for aircraft applications.

Introduction

The military wants to reduce volatile organic compounds and hazardous air pollutants released during the production and application of corrosion protection coatings. Powder coatings are an inherently solvent free alternative.¹⁻⁵ There are numerous military and civilian applications that require protective coatings but involve substrates that are made from materials such as low-tempered metal alloys, composites, plastic, or wood that would be structurally compromised by thermal treatments required to cure conventional powder coatings. The need for powder coatings that cure at ever lower temperatures has been presented extensively and much work on their development has been reported in the literature.⁶⁻²²

This paper highlights research to develop a weatherable powder coating that cures at 120 °C within 30 minutes. This builds on previously reported work.^{23,24} For specific military applications, this cure schedule is dictated by the temperature sensitive nature of 2024-grade aluminum alloy that is used in several types of aircraft parts, weapon systems, and support equipment. Due to the T3 heat treatment, prolonged exposure to temperatures above 120 °C can compromise the structural integrity of the alloy. In addition to the low temperature cure target, the final coating must fulfill performance specifications defined by MIL-PRF-85285D. An abbreviated summary of these performance criteria is provided in Table 4.1. These reflect the performance requirements for ground support equipment, which is the primary target for this research.

Table 4.1 Target performance specifications for 120 °C – 30 min cure powder coating.

Property	Test	Units	Specification*	
			LSL	USL
Thickness	Gauge (eddy current, magnetic induction)	mils	2.3	3.2
Adhesion	Crosshatch ASTM D3359-97	ASTM scale	4B	-
Flexibility	Mandrel Bend ASTM D522-93	failure dia. in.	-	0.25
Toughness	GE Impact Support Equip.	% Elongation	5	
	GE Impact Aircraft Equip.	% Elongation	40	-
Hardness	Pencil Hardness ASTM D3363	pencil #	2H	-
Exterior Durability	Xenon Arc, 2000 hrs ASTM G26-96	delta color	-	1
Chemical Resistance	Mil-H-83282 Fluid Immersion 24 hrs.	delta pencil #	-	2
	Mil-H-5606 Fluid Immersion 24 hrs.	delta pencil #	-	2
	MEK Double Rub ASTM D5402	double rubs	25	
Gloss	60° Gloss ASTM D523	gloss units	90	-
Surface Quality [†]	DOI Wavescan, calibrated to PCI standards	standard #	4	-
Corrosion Resistance	Salt Fog, ASTM B117	hrs to failure	2000	-
	SO2 500 hrs, ASTM G85	scribe undercut rating	7	-
	Cyclic on scribed steel GM 9540P	cycles to failure	80	-
	Filiform ASTM 2803-93	in.	-	0.25

This report summarizes research conducted to develop a low temperature cure powder coating that meets the requirement given in Table 4.1. The work includes investigation of catalysts, resins, corrosion and flow additives, pigment concentration, as well as processing and application conditions.

Experimental

Materials and Test Substrates

All materials used in this study, including finished powders and raw materials, were used as received from their manufacturers. In formulation studies low flow and high flow acid functional polyester resins with corresponding equivalent molecular weights of 1650 and 1600 were combined 93:7 with triglycidylisocyanurate (TGIC) (Araldite PT 810, Huntsman Chemical). Two GE resins, at two molecular weights (2.9K Mw and 6.5K Mw), were also investigated as part of this research. Three catalysts were used in this work: Choline chloride (Aldrich Chemical), Benzyltrimethylammonium bromide (Aldrich Chemical) & a GE experimental catalyst. Three types of flow additives were used: silica bound flow additive (Resiflow P-67, Lubrizol), a master-batched flow additive (Additol VXL9991, UCB Chemical), and an experimental master-batched flow additive formulated at Crosslink Powder Coatings (Modaflow 2100, UCB Chemicals). Other additives evaluated include TiO₂ (Kerr McGee) and a Triazine UV absorber (Tinuvin 405).

Chromated aluminum, 2024T3, was the primary substrate for this research. For testing GE Impact a thinner (.020 in.) softer version of 2024 T0 was used with no surface

treatment. Conical flexibility requires a slightly thicker version, (.032 in.) treated according to MIL-A-8625 Type I. All aluminum test substrates were obtained from Q-Panel Lab Products. For Gardner impact testing untreated 1008 steel panels (R-46, Q-Panel Lab Products) were used.

Coating Formulations

Table 4.2 lists the common components that make up a low temperature powder coating system. All coatings are built from the following general composition:

Table 4.2 Typical powder formulation for low temperature cure.

Coating Component	Sample Formula
Crosslinker	TGIC
Acid Polyester*	Polyester Resin
Curing Catalyst*	CC-6 Choline Chloride
Flow Promoter*	Resiflow P-67
Degassing Agent	Benzoin
Antioxidant	Arenox A76G
Corrosion inhibitor	Barium metaborate
Pigment*	CR-880 TiO2
Pigment	YLO 1888D Yellow Iron Oxide
Pigment	Green # 5320

*Components adjusted to obtain required coating properties.

Melt Compounding and Powder Grinding

Raw materials were dry blended by either hand shaking in a bag (1 min) or in a Henschel mechanical mixer (60 sec at 2000 rpm). For lab scale processing at Crosslink Powder Coatings, formulations were then melt-mixed on a 50 mm twin-screw extruder (lab model Baker Perkins) at 500 rpm with a max barrel temperature of 88 °C. Extrudate was passed through water-cooled pinch-rolls and collected onto a stainless steel belt; from exit of the extruder, approximately 60 sec. was required to reach ambient temperature.

Production scale processing at Crosslink Powder Coatings made use of a 50 mm twin-screw extruder (production model Baker Perkins) at 400 rpm and a max barrel temperature of 107 °C. Extrudate is cooled to ambient temperature within 7 sec. using a water-cooled pinch roll with automated kibbling. For both methods, powder grinding was performed using an air-classifying mill (ACM-5) followed by sieving through a 140-mesh screen. This process produced powders with a mean size of 40 - 50 microns (95% < 105 microns) as measured using a Malvern Series 2600 laser analyzer.

Most coatings were melt processed and prepared as powders as described above. Where noted formulations were made at GRC according to the following procedure. Raw materials were dry-blended in a 1-liter Henschel mechanical mixer (60 sec at 2500 rpm). Melt mixing employed the use of a 16 mm twin-screw extruder (lab model Prism) at 250 rpm with a max barrel temperature of 100 °C. For cooling, the extrudate was passed through a water-cooled chill roll (lab model BBA).

Thermal Analysis

Samples, 15-20 mg in size, were analyzed using a Perkin Elmer DSC 7. The testing protocol utilized an isothermal hold at 120 °C for 30 minutes followed by a rapid quench and then a temperature scan from 25-300 °C at 10 °C/min. Heat of reaction and the corresponding cured powder percent conversion curve were obtained from the isothermal portion of the test while the cured network Tg and residual heat of reaction were assessed from the follow-up scan. Both heats of reaction were used to calculate actual percent conversion at 120 °C for 30 minutes.

Coating Preparation

Prior to coating, test substrates were cleaned with a MEK wipe. All powders were applied in an ETI Flexicoat[®] manual powder coating booth using a Nordson SureCoat[®] cup gun with an applied voltage of 70 kV, application pressure of 30 psi, and rinse rate setting of 20 psi. Curing was performed in a Blue-M convection oven. For each panel, mean coating thickness and standard deviation was monitored based on 6 measurements using an ElektroPhysik Minitest 4100. After curing, panels were held at ambient conditions for a minimum of 24 hours before testing.

Property Evaluation

Adhesion testing was performed using a Gardner crosshatch knife and Permacel[®] tape in accordance with ASTM D3359. Flexibility testing followed ASTM D522 and was performed with a Gardner mandrel bend tester. Direct impact strength was tested in accordance with ASTM D5420 using a Gardner impact tester. GE Impact strength is reported as percent elongation and performed following CTIO lab procedure CCG-LP-016 REV 06. Pencil hardness was assessed following ASTM D3363. Solvent resistance was determined using the MEK double rub test, ASTM D5402, with failure reported at substrate read-through.

SO₂ and Salt Fog corrosion tests were performed using standard ASTM test methods G85 and B117, respectively, on both steel and aluminum substrates. For salt fog testing, time to failure, assessed as greater than 1/8" undercutting from edge of scribe on coating, up to the test duration of 2000 hours is reported. For SO₂ testing, performance is reported as creep after 500 hours of exposure rated on an ASTM scale. A failure rating of 6 corresponds to undercutting from edge of scribe by more than 1/16".

For accelerated weathering an Atlas Ci35a Xenon Weather-Ometer[®] was used. To assess performance, color coordinates were measured as a function of exposure using a Macbeth Colorimeter (Color-Eye 7000A) following ASTM D2244. The ΔE color change is reported after 500 hrs of exposure.

Gloss was measured at 20° and 60° using a BYK Gardner Tri-Gloss Meter. 20° gloss was measured when the 60° gloss was 70% or greater. Coating surface quality was determined using a BYK Gardner Wavescan[™] Distinctness of Image (DOI) instrument with the Wd output calibrated relative to Powder Coating Institute (PCI) surface quality standards. Results are reported in PCI units ranging from 1-10, with 10 corresponding to

the best quality (PCI=(Wd-84)/-7.29). In samples where gloss was inadequate to allow use of the Wavescan, visual assessments were made using side-by-side comparison to the surface quality standards.

Hydraulic Immersion Testing

Testing was performed according to MIL-PRF-85285D. All test fluids used in this study were used as received. Cured panels were immersed in a petridish containing one of two grades of hydraulic fluid, MIL-H-5606 or MIL-H-83282, and then placed in a 66° +/- 3°C equilibrated oven for twenty-four hours. Next, the test specimens were evaluated for blistering, pencil hardness and adhesion. The initial values for hardness and adhesion were determined relative to untested panels. Chromated aluminum, 2024T3, was the primary substrate for this research. All aluminum test substrates were obtained from Q-Panel Lab Products.

Results and Discussion

Catalyst Level, Manufacturing Method, and Particle Size Screening

Building on previously reported results, Choline chloride (CC) catalyst at levels of 0.6 and 0.75 percent of total formulation weight (TFW) were investigated to target improved mechanical properties.²⁴ Additionally, two manufacturing methods were screened to gauge capability to move from lab scale (Screw speed: 500 rpm, cooling: 60 seconds) to production scale (Screw speed: 400 rpm, cooling: 7 seconds). Finally, two particle size distributions with mean values of 40µ and 50µ were evaluated to assess their effect on surface quality. A total of eight distinct formulations, with two replicates, were produced at Crosslink Powder Coatings, Inc. The experimental layout is shown in Figure 4.1.

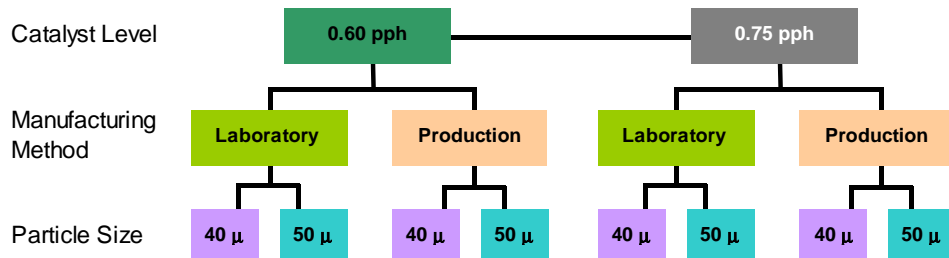

Figure 4.1 Experimental design to evaluate catalyst level, manufacturing method, and particle size.

The results for this experiment are shown in Table 4.3. Across the full range of coatings acceptable performance was demonstrated in adhesion, flexibility, toughness, hardness, and chemical resistance, but deficiencies remain in gloss and surface quality. Smaller particle size helped enhance surface quality and therefore was down selected for use in all future experiments. These results show good correlation between compositions created at lab and production scales. The two methods show agreement with respect to adhesion, flexibility, hardness, fluid resistance and surface quality. Slight differences in toughness and MEK double rubs may be attributed to differences in coating thickness (thicker film build giving rise to lower toughness but higher chemical resistance). Although not included in Table 4.3 data, the higher catalyst level produced a higher heat of reaction (on average 2.6 J/g) and increased coating Tg (on average 1.1 °C).

Table 4.3 Scorecard results for catalyst level, manufacturing method, and particle size. Green fill indicates pass and red failure relative to specifications provided in Table 4.1.

Property	Test	0.6 pph Catalyst					0.75 pph Catalyst				
		40 μ		50 μ			40 μ		50 μ		
		Lab	Prod.	Prod.	Lab	Prod.	Lab	Prod.	Prod.	Lab	Prod.
Adhesion	Crosshatch	5B	5B	5B	5B	5B	5B	5B	5B	5B	5B
Flexibility	Mandrel Bend	Pass	Pass	Pass	Pass	Pass	Pass	Pass	Pass	Pass	Pass
Toughness	G.E. Impact--Support Equip.	20%	60%	10%	2%	10%	40%	10%	5%	20%	5%
	G.E. Impact--Aircraft	20%	60%	10%	2%	10%	40%	10%	5%	20%	5%
Hardness	Pencil	2H	2H	2H	2H	2H	2H	2H	2H	2H	2H
	MEK DR	83	63	181	93	91	141	69	71	82	111
Chem Resist.	Hydrc. Fld. Mil-H-83282	0	0	1	0	0	0	0	1	1	0
	Hydrc. Fld. Mil-H-5606	0	0	0	0	0	0	0	0	0	0
Gloss	60° Gloss	45	58	48	57	51	49	47	50	51	49
Surface Quality	DOI	3	3	3	2	2	3	3	2	2	2

Resin Type, Flow Additives and Inorganics Level

Figure 4.2 builds on the 40 μ m mean particle size down-selected above and outlines a study to investigate resin type, flow additives, and inorganic level. This incorporates the low temperature cure catalyst, Benzyltrimethylammonium bromide (Aldrich Chemical) down-selected in screening experiments reported elsewhere.²³ It targets improvement of surface quality and gloss found deficient in the study described above. A new high-flow, super-durable resin was compared to the previously investigated standard flow resin. In addition, two flow additive types, silica-bound and master-batched, were examined for improved surface leveling. Finally, discrete adjustments of the inorganics level were carried out to optimize flow while maintaining sufficient hiding power.

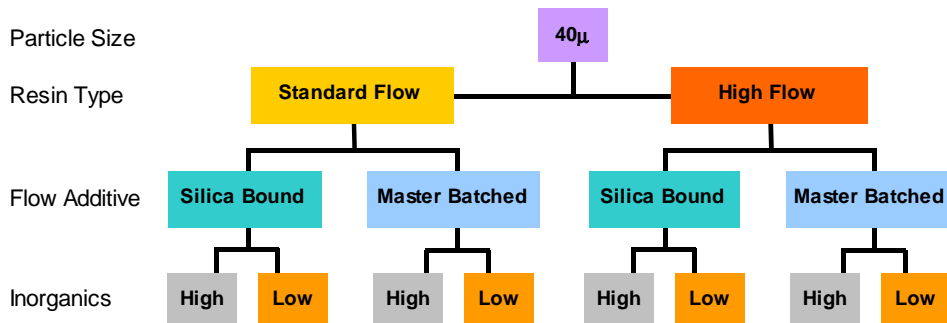

Figure 4.2 Experimental design to evaluate resin type, flow additives and inorganics level.

The results for this study are shown in Table 4.4. Performance properties that were unaffected by experimental factors but still met specification requirements were adhesion, flexibility, and hardness. Resin type had a large effect on surface quality and toughness. The high flow resin improves gloss and surface quality to specification requirements. However, a tradeoff is seen with a 13% decrease in toughness and 20 MEK double-rub reduction in chemical resistance. Increasing catalyst level from the current 0.5% TFW will be investigated in future compositions to improve toughness. Flow additive type did not affect coating performance. Lowering the level of inorganics from 22% to 17% did not reduce hiding power beyond an acceptable level as determined in a Linetta panel study; however, a slight benefit in increased gloss was noted. Deficiencies in weatherability were independent of formulation changes and will be addressed in future experiments. Overall, the most improved formulations incorporated

the high-flow, super-durable resin and the 17% inorganic level. These improvements are carried through to future formulation developments.

Table 4.4 Results investigating resin type, flow additive type, and inorganics level.

Property	Test	Standard Flow				High Flow				
		Silica Bound		Master Batched		Silica Bound		Master Batched		
		High	Low	High	Low	High	Low	High	Low	
Adhesion	Crosshatch	5B	5B	5B	5B	5B	5B	5B	5B	
Flexibility	Mandrel Bend	Pass	Pass	Pass	Pass	Pass	Pass	Pass	Pass	
Toughness	G.E. Impact--Support Equip.	20%	10%	10%	10%	2%	2%	1%	5%	
	G.E. Impact--Aircraft	20%	10%	10%	10%	2%	2%	1%	5%	
Hardness	Pencil	2H	2H	2H	2H	2H	2H	2H	2H	
Chem Resist.	MEK DR	66	49	94	79	52	44	37	74	
	Hydrc. Fld. Mil-H-83282	0	0	0	0	0	0	0	0	
	Hydrc. Fld. Mil-H-5606	0	0	0	0	0	0	0	0	
Weathering	Xenon-arc (500 hrs)	ΔGloss	12	-	11	-	10	12	15	8
		ΔColor	0.1	0.1	0.3	0.4	0.3	0.4	0.2	0.3
Gloss	60° Gloss	38	41	43	44	89	91	94	97	
	20° Gloss	-	-	-	-	59	57	65	81	
Surface Quality	DOI	3	3	3	3	4	4	4	3	

Increased Catalyst Level, Flow Additive, UV Absorber

The present study targets improvements to toughness and weathering. A high-flow, super-durable resin and a 17% inorganic level were down-selected as described in the preceding section. Catalyst level was increased to 0.6% TFW (increase by 0.1% from earlier work) in attempt to improve mechanical properties without compromising flow. Silica-bound and master-batched flow additives were carried through into this work. A UV absorber (UVA) was introduced to improve gloss stability during weathering. Finally, a control without corrosion inhibitor or UVA was included.

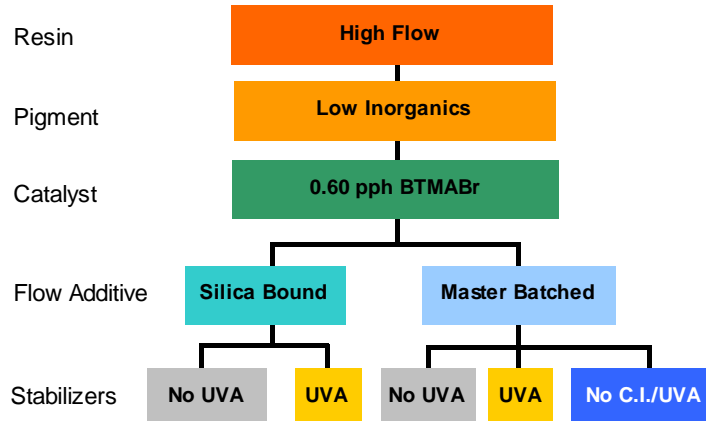

Figure 4.3 Coatings evaluating increased catalyst level, flow additive, UV absorber.

Results from this experiment are shown in Table 4.5. The combination of the silica-bound flow additive and the increased catalyst level improved toughness to the specification requirement; at the same time surface quality was not compromised. Previous Δgloss values of greater than ten were improved upon across the board in the present study independent of UVA. This is shown in Figure 4.4. In fact, the inclusion of the UVA imparted additional color as a function of xenon arc exposure seen in Figure 4.5. Unexpectedly, the composition without corrosion inhibitor or UVA exhibited poor

flexibility. In this work, two formulations have been developed that met all screening requirements summarized in Table 4.5 for ground support equipment. More stringent aircraft applications have additional toughness requirements that are not met by these solutions, but will be addressed later in this report.

Table 4.5 Increased catalyst level, flow additives, and UVA results.

Property	Test	High Flow				
		Silica Bound		MasterBatched		
		No UVA	UVA	No UVA	UVA	No C.I./UVA
Adhesion	Crosshatch	5B	5B	5B	5B	5B
Flexibility	Mandrel Bend	Pass	Pass	Pass	Pass	Fail
Toughness	G.E. Impact--Support Equip.	5%	5%	2%	5%	2%
	G.E. Impact--Aircraft	5%	5%	2%	5%	2%
Hardness	Pencil	2H	2H	2H	H	2H
	MEK DR	58	67	86	80	75
Chem Resist.	Hydrc. Fld. Mil-H-83282	0	0	0	0	0
	Hydrc. Fld. Mil-H-5606	0	0	0	0	0
	Xenon-arc					
Weathering	Δ Gloss	3	2	6	3	3
	(500 hrs) Δ Color	0.1	0.5	0.1	0.6	0.1
Gloss	60° Gloss	91	91	92	94	91
	20° Gloss	65	66	12	78	66
Surface Quality	DOI	4	5	3	4	4

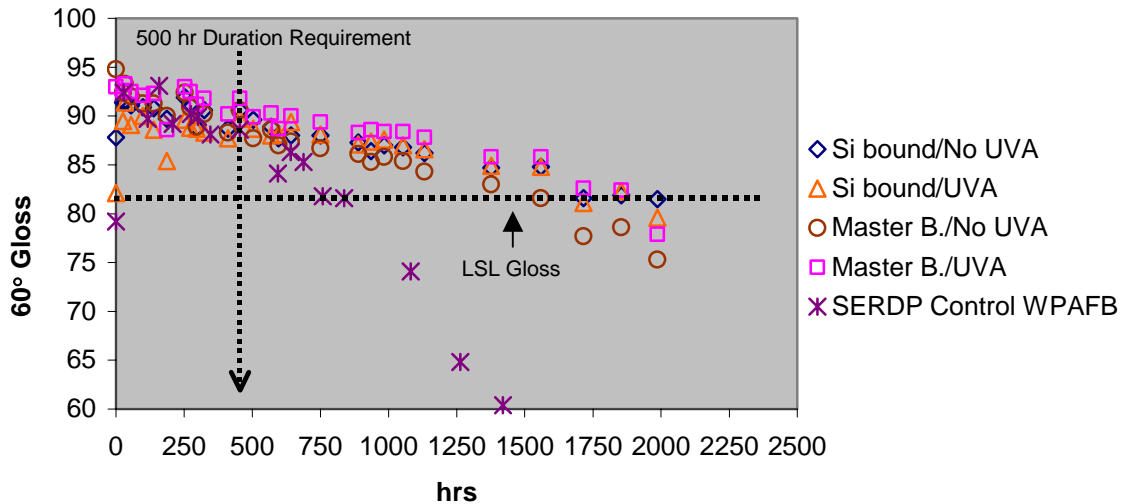

Figure 4.4 Increased catalyst level, flow additives, and UVA weathering results—60° gloss.

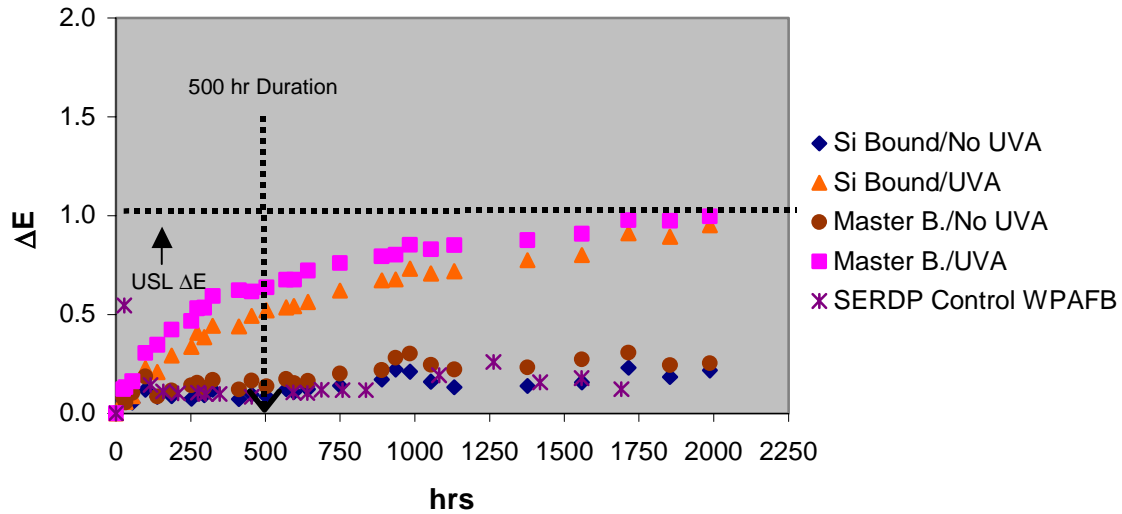

Figure 4.5 Increased catalyst level, flow additives, and UVA weathering results — ΔE .

Flow Additive Master-Batched in High-Flow, Super-Durable Resin

Although surface quality was found to be adequate in previous experiments opportunity exists for further improvement by combining a non silica-bound, liquid flow additive directly into the high-flow, super-durable resin. The master batch was created by melt extruding Modaflow 2100 (Solutia) with the high-flow polyester resin. Two catalyst levels were considered, 0.5% and 0.6 % TFW, to probe the effect on flow. Figure 4.6 diagrams the formulations investigated here. The results from the previous study showing UVA to be insignificant were not determined when these formulations were prepared; therefore, it is included in the present study.

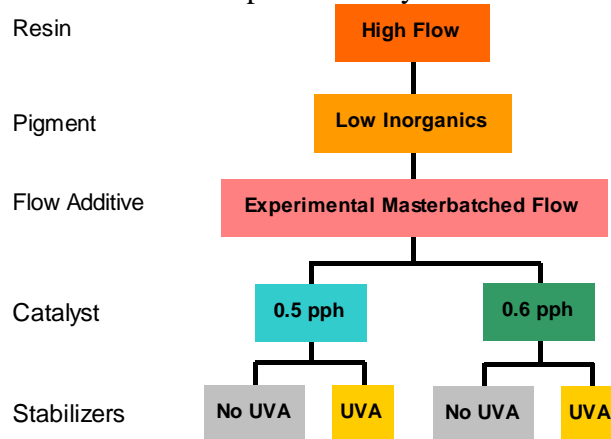

Figure 4.6 Experimental flow additive formulations

Table 4.6 summarizes the screening performance of the prepared coatings. As hoped, the master batch flow additive improved surface quality about 1-2 PCI units compared to analogues summarized in Table 4.5. Neither the master batch nor lowering catalyst level improved gloss. In fact, gloss was significantly decreased for all but one formulation. In some cases the formulation changes also brought a reduction in toughness. Pre-reaction during melt compounding could have contributed to these unexpected observations.

Table 4.6 Experimental flow additive results

Property	Test	High Flow			
		Low Inorganics			
		Experimental Mastebatched Flow			
		.5 pph BTMABr		.6 pph BTMABr	
		No UVA	UVA	No UVA	UVA
Adhesion	Crosshatch	5B	5B	5B	5B
Flexibility	Mandrel Bend	Pass	Pass	Pass	FAILS
Toughness	G.E. Impact--Support Equip.	2%	2%	5%	2%
	G.E. Impact--Aircraft	2%	2%	5%	2%
Hardness	Pencil	2H	H	2H	2H
Chem Resist.	MEK DR	46	50	65	38
	Hydrc. Fld. Mil-H-83282	0	0	0	0
	Hydrc. Fld. Mil-H-5606	0	0	0	0
Gloss	60° Gloss	69	85	90	73
	20° Gloss	33	58	65	38
Surface Quality	DOI	6	5	4	6

GE Resin and Catalyst

Up to this point, formulation developments have been targeted at meeting property requirements for support equipment. This next set of powders investigated the use of an experimental GE resin and GE catalyst to meet more stringent toughness and chemical resistance specifications for aircraft equipment. The experiment design was split into two parts. In part 1, shown in Figure 4.7, three resins (high-flow polyester, standard-flow polyester, and GE Resin A) were blended with each of two catalysts (BTMABr, and GE Cat.). In part 2, shown in Figure 4.8, the same three resins were blended in varying ratios in formulations along with the two catalyst types. UVAs were not included in these formulations based on results reported above.

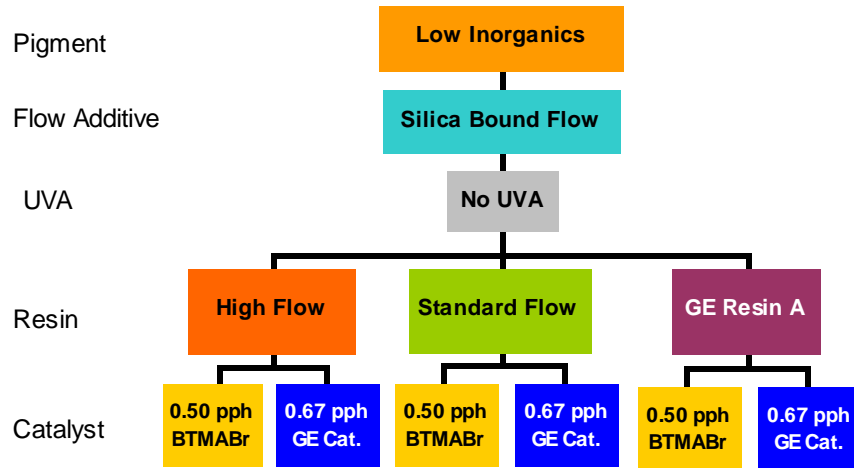

Figure 4.7 Experimental resin and catalyst part 1 formulation plan.

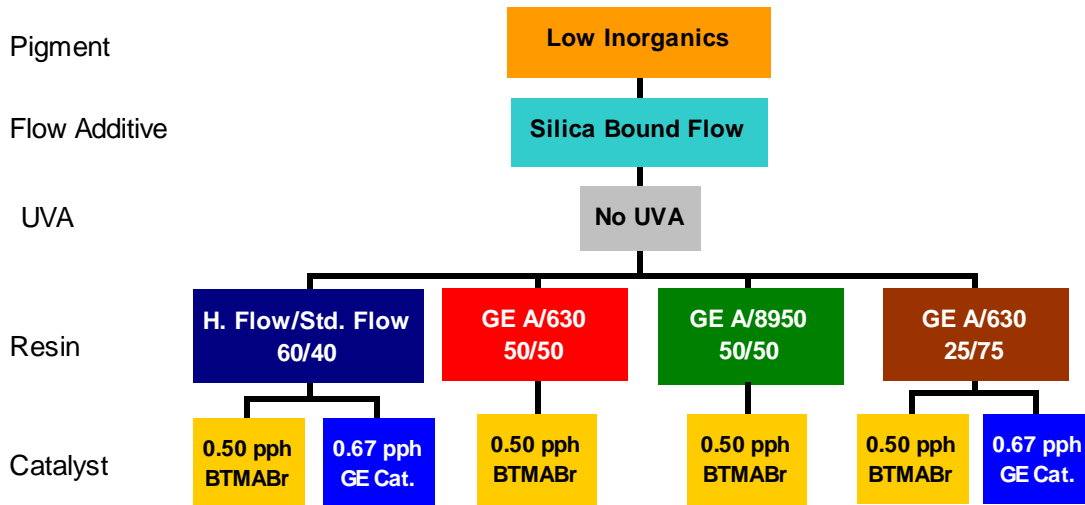

Figure 4.8 Experimental resin and catalyst part 2 formulation plan.

The results corresponding to Figure 4.7 and 4.8 are provided in Tables 4.7 and 4.8. The coatings containing the GE resin exhibited improved toughness, MEK double rubs, and surface quality. Compared to the incumbent system, toughness was increase up to 8% in elongation, MEK double rubs increased by 150 units, and surface quality increased 1 to 2 PCI units. Even though these results are encouraging, dilution with purge resin during melt compounding is suspected because of a noted loss in hiding powder and loss in mechanical properties. Reformulation of these coatings is considered in the section to follow. Lastly, the GE catalyst did not bring any advantages over the commercial catalyst.

Table 4.7 Experimental resin and catalyst results part 1.

Property	Test	High Flow	Standard Flow		GE Resin A	
		0.5 BTMABr	0.5 BTMABr	0.67 GE Cat.	0.5 BTMABr	0.67 GE Cat.
Adhesion	Crosshatch	5B	5B	5B	5B	5B
Flexibility	Mandrel Bend	Pass	Pass	Pass	Pass	Pass
Toughness	G.E. Impact--Support Equip.	2	8	5	4	10
	G.E. Impact--Aircraft	2	8	5	4	10
Hardness	Pencil	2H	F	F	H	2H
Chem Resist.	MEK DR	69	80	43	<200	<200
Gloss	60° Gloss	82	37	22	57	36
	20° Gloss	46	9	5	18	8
Surface Quality	DOI	4	4 (visual)	5 (visual)	5 (visual)	5 (visual)

Table 4.8 Experimental resin and catalyst results part 2.

Property	Test	GE A/630 50/50	GE A/8950 50/50	GE A/630 25/75		High Flow/Standard Flow 60/40	
		0.5 BTMABr	0.5 BTMABr	0.5 BTMABr	0.67 GE Cat.	0.5 BTMABr	0.67 GE Cat.
Adhesion	Crosshatch	5B	5B	5B	5B	5B	5B
Flexibility	Mandrel Bend	Pass	Pass	Pass	FAILS	Pass	Pass
Toughness	G.E. Impact--Support Equip.	10	10	10	10	5	5
	G.E. Impact--Aircraft	10	10	10	10	5	5
Hardness	Pencil	H	2H	3H	3H	2H	H
Chem Resist.	MEK DR	56	30	87	39	78	93
Gloss	60° Gloss	47	41	24	37	56	55
	20° Gloss	12	8	5	9	18	16
Surface Quality	DOI	5 (visual)	6 (visual)	6 (visual)	5 (visual)	5 (visual)	2 (visual)

GE Resin Reformulations

The set of formulations shown in Figure 4.9 reevaluates the use of GE resin to help improve coating performance. All these materials were prepared at GEGR. Two different GE resins, referred to as GE A and B, with molecular weight averages (weight average) of 2900 and 6500 were formulated separately at 100% and in blends with Crylcoat 630 at the two levels shown. A 100% Crylcoat formulation was also included as a control.

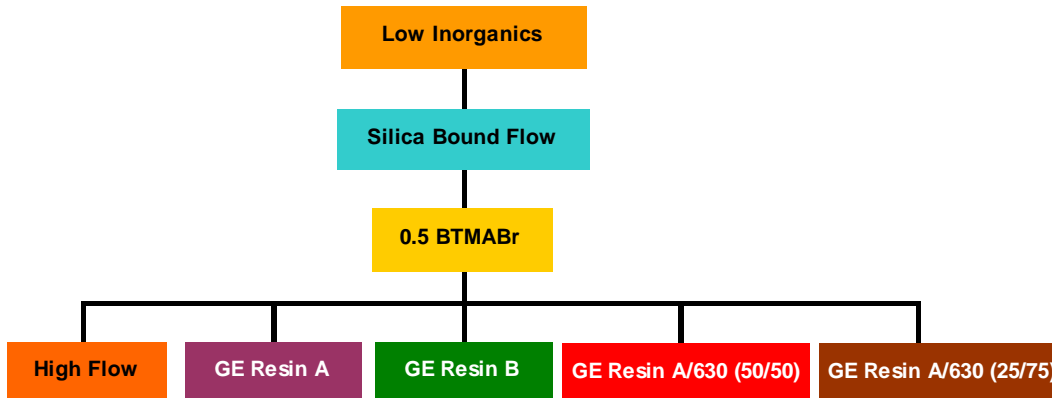

Figure 4.9 Experimental resin reformulation

Results from this study are given in Table 4.9. The coating based on the higher molecular weight GE Resin at 100% improved elongation to 40% and brings toughness performance in line with aircraft specifications. This was not observed with the lower molecular weight material at 100%, but when combined with a polyester co-resin at 50/50 and 25/75 elongation improved to 20% and 5%, respectively. All coatings with the GE resins showed a stepwise improvement in MEK DR performance, nearly hitting the maximum of 200 units with even the lowest GE resin content. At the same time, a loss in gloss is suffered with GE resin incorporation at the 100% levels. Blending with a polyester co-resin completely mitigated the gloss reduction. Overall, the required surface quality was maintained for all formulations (low gloss of the 100% GE resin coatings precluded DOI measurements but visual assessments suggest acceptable quality).

Table 4.9 Experimental resin reformulation

Property	Test	High Flow	GE A 100%	GE B 100%	GE A/630 50/50	GE A/630 25/75
		0.5 BTMABr	0.5 BTMABr	0.5 BTMABr	0.5 BTMABr	0.5 BTMABr
Adhesion	Crosshatch	5B	5B	5B	5B	5B
Flexibility	Mandrel Bend	Pass	Pass	Pass	Pass	Fails
Toughness	G.E. Impact--Support Equip.	1	2	40	20	5
	G.E. Impact--Aircraft	1	2	40	20	5
Hardness	Pencil	2H	2H	2H	2H	3H
Chem Resist.	MEK DR	44	>200	>200	186	179
Gloss	60° Gloss	85	44	56	86	85
	20° Gloss	49	----	----	50	45
Surface Quality	DOI	5	----	----	5	5

Conclusions

This work has highlighted the challenge of simultaneously meeting all coating performance requirements in a low temperature cure powder coating. In particular, balancing surface quality and gloss with mechanical performance proved difficult. Once an acceptable balance was achieved, further improvement of surface quality was limited by a tradeoff in gloss. Even so, through selection of and refinements to particle size, resin, flow additive, catalyst level, and pigment concentration a coating was developed that meets all military specifications for ground support equipment. In future work, this candidate will be carried through to formulation optimization, qualification testing, and assessment of field reparability. As part of this effort an experimental GE resin was shown to offer enhanced toughness and chemical resistance. These improvements show potential to help meet the requirements for more stringent aircraft applications. Work with the GE resin will continue.

Acknowledgements

This research was supported in part by the U.S. Department of Defense Contract DACA72-02-C-0025, through the Strategic Environmental Research and Development Program (SERDP), Pollution Prevention Program Manager Chuck Pellerin.

References

1. Miller, E. P.; Taft, D. D. *Fundamentals of Powder Coating*; Society of Manufacturing Engineers: Dearborne, MI, **1974**.
2. Misev, T. A. *Powder Coatings: Chemistry and Technology*; John Wiley & Sons: New York, **1991**.
3. Richart, D. S. *Coating Processes (Powder Technology)*; Howe-Grant, M., Ed.; John Wiley & Sons, Inc.: New York, **1993**; Vol. 6, pp 635-661.
4. Misev, T. A.; van der Linde, R. *Prog. Org. Coat.* **1998**, *34*, 160-168.
5. Farrel, R. *Metal Finishing* **2000**, *98*, 135-141.
6. Armstrong, B. *Powder Coating* **2002**, *Sep*, 60-61.
7. Bergmans, A.; DeCock, C.; Bertens, J.; Kooijmans, P., Shell International Research, *Acid Functional Polyester Resins and Lower Temperature Curable Powder Coating Compositions Comprising Them*, **2000**; European EP 1,006,163.
8. Bergmans, A.; Walravens, M.; DeCock, C.; Riviere, J. *Polymers Paint Colour Journal* **2001**, *Oct*, 17-19.
9. Danick, C. *Low Temperature Crosslinking for Powder Coatings*; Federation of Societies for Coatings Technology International Coatings Conference, New Orleans, LA, **1998**.
10. Johansson, M.; Malmstrom, E.; Jansson, A. *J. Coat. Techn.* **2000**, *72*, 49-54.
11. Laas, H. J.; Meier-Westhues, H. U.; Halpaap, R.; Freudenberg, U.; Klee, H. P., Bayer, *Polyurethane Powder Coating Compositions Which Have a Low Stoving Temperature*, **1998**; U.S. 5,847,044.
12. Malmstrom, E.; Johansson, M.; Jansson, A.; Hult, A. *Novel Concept for Low Temperature Curing Powder Coatings Based on Hyperbranched Polymers*; Proceedings of the International Waterborne, High Solids and Powder Coatings Symposium, New Orleans, LA, **1999**, pp 373-382.
13. McBride, P. J. *J. Oil. Col. Chem. Assoc.* **1982**, *65*, 257-262.

14. Pappas, S. P.; Hill, L. W. *J. Coat. Techn.* **1981**, 53, 43-50.
15. Pont, J. D. *Further Advances in Low Temperature Cure Polyurethane Powder Coatings*; Proceedings of the International Waterborne, High Solids and Powder Coatings Symposium, New Orleans, LA, **1999**, pp 232-245.
16. Rijkse, K. *Modern Paint & Coatings* **2001**, April, 36-39.
17. Roescher, A.; DeRuiter, B. *New Isocyanate-Based Low-Temperature Hardeners for Powder Coatings*; Proceedings XXV FATIPEC Congress, Torino, Italy, **2000**, pp 175-190.
18. Ruth, W. G.; Greth, S. L.; Seelig, C. A.; Schreffler, D. A., Morton International Inc., *Powder Coating of Non-Crystalline and Crystalline Epoxy Resins*, **2000**; U.S. 6,140,430.
19. Sohoni, M.; Figlioti, P. *Developments in Low Temperature Cure: Urethane Powder Curing Agents*; Proceedings of the International Waterborne, High Solids and Powder Coatings Symposium, New Orleans, LA, **1998**, pp 267-280.
20. Subramanian, R.; Sullivan, C. J. *Unsaturated Polyesters in Low Temperature Cure Powder Coatings*; Proceedings of the International Waterborne, High Solids and Powder Coatings Symposium, New Orleans, LA, **2001**, pp 381-389.
21. Wenning, A.; Franzmann, G.; Spyrou, E., Degussa AG, *Powder Coating Compositions Comprising Crystalline Urethane Acrylates and Use Thereof*, **2003**; US 0175433 A1.
22. Witzeman, J. S. *Prog. Org. Coat.* **1996**, 27, 269-276.
23. Merfeld, G.; Mordhorst, S.; Koeniger, R.; Acar, A. E.; Molaison, C.; Suriano, J.; Irwin, P.; Warner, R.; Gray, K.; Smith, M.; Kovalski, K.; Finley, S.; Meredith, D.; Naguy, T.; Spicer, M. *Development of Low Temperature Curing (120 °C) Corrosion Protection Powder Coatings for Thermally Sensitive Substrates*; Proceedings of the International Waterborne, High-Solids, and Powder Coatings Symposium, New Orleans, **2004**.
24. Merfeld, G.; Molaison, C.; Koeniger, R.; Acar, A. E.; Mordhorst, S.; Suriano, J.; Irwin, P.; Warner, R.; Gray, K.; Smith, M.; Kovalski, K.; Finley, S.; Meredith, D.; Naguy, T.; Spicer, M. *Acid/Epoxy Catalyst Screening for Low Temperature (120°C) Powder Coatings*; Proceedings of the International Waterborne, High-Solids, and Powder Coatings Symposium, New Orleans, **2004**.

Chapter 5: Screening Corrosion Inhibitors in Low Temperature Curing, 120 °C – 30 min, Powder Coatings for Temperature Sensitive Substrates

Abstract

No commercial powder coatings exist that cure at 120 °C within 30 minutes and simultaneously meet military requirements for corrosion resistance, weatherability, toughness, chemical resistance, gloss, and surface quality. This work focuses on fulfillment of corrosion requirements by evaluating the performance of 8 candidate corrosion inhibitors in TGIC crosslinked polyester powder coating formulations. On the primary substrate of aluminum (chromated AL2024), seven of the eight additives provided adequate protection to pass SO₂ and salt fog corrosion tests. The effect of the additives was better differentiated in studies on steel (phosphatized CRS1008) and untreated aluminium (non-chromated AL2024). Building off these work, future efforts will look to coordinate mechanical performance, including adhesion, chemical resistance, and impact toughness, with required corrosion performance. In choosing the final corrosion inhibitor for this application the potential interaction of the corrosion inhibitor with catalyst and how this influences coating properties will also be addressed.

Introduction

The military wants to reduce volatile organic compounds and hazardous air pollutants released during the production and application of corrosion protection coatings. Powder coatings are a viable alternative as they are inherently solvent free.¹⁻⁵ There are numerous military and civilian applications that require protective coatings but involve substrates that are made from materials such as low-tempered metal alloys, composites, plastic, or wood that would be structurally compromised by thermal treatments required to cure conventional powder coatings. The need for powder coatings that cure at ever lower temperatures has been presented extensively and much work on their development has been reported in the literature.⁶⁻²²

Corrosion performance is a critical property for the target application of the powder coating under development. This paper highlights research to target improvements in the corrosion performance of a weatherable powder coating that cures at 120 °C within 30 minutes. It also builds on previously reported work.^{23,24} For specific military applications, this cure schedule is dictated by the temperature sensitive nature of 2024-grade aluminum alloy that is used in several types of aircraft parts, weapon systems, and support equipment. Due to the T3 heat treatment, prolonged exposure to temperatures above 120 °C can compromise the structural integrity of the alloy. In addition to the low temperature cure target, the final coating must fulfill performance specifications defined by MIL-PRF-85285D.

Experimental

Materials and Formulations

All materials evaluated in this study, including finished powders and raw materials, were used as received from their manufacturers. In formulation studies acid functional polyester resin (Fineclad M8950, Reichhold) with a corresponding equivalent molecular weight of 1650 was combined 93:7 with triglycidylisocyanurate (TGIC) (Araldite PT-810, Huntsman Chemical). The silica bound flow additive, Resiflow P-67, promotes surface quality by improving the flow and levelling of the powder coating. Benzoin is a degassing agent that allows gas to escape during cure, Arenox A-76-G is a hindered amine light stabilizer (HALS) that stabilizes the coating during UV exposure, and TiO₂ (Kerr McGee) provides pigmentation. A summary of all the components that make up the powder coating is shown in Table 5.1. The generic formulation in parts by total weight is 63% acid polyester, 5% TGIC crosslinker, 1.5% flow additive, 0.5% degassing agent, 1% HALS, 24-26% TiO₂, and 3-5% corrosion inhibitor. The latter two components were adjusted to allow equivalent inhibitor levels in each formulation by maintaining the same ratio of pigment volume concentration (PVC) to critical pigment volume concentration (CPVC).²⁵

Table 5.1 Formulation components.

Coating Component	Sample Formula
Crosslinker	Araldite PT-810 TGIC
Acid Polyester	Reichhold M8950 Polyester
Flow Promoter	Resiflow P-67
Degassing Agent	Benzoin
Antioxidant	Arenox A-76-G
Corrosion inhibitor	Butrol 23
Pigment	TiO ₂

The eight corrosion inhibitors investigated are shown in Table 5.2. These inhibitors have been color coded to aid in tracking their performance in the figures to follow. TiO₂ is included in the list as it is an exterior grade pigment that offers good barrier properties to protect the substrate from the environment. Three zinc-based compounds were evaluated in this study including strontium zinc phosphosilicate (SZP-391), zinc phosphate, and a zinc salt of hydrophobic sulfonic acid (Nacor 6401). Two barium compounds were investigated, barium metaborate (Butrol 23) and barium metaborate monohydrate (Busan 11-M1). Finally, calcium phosphosilicate (CW-491) and an organic corrosion inhibitor, (1-benzothiazol-2-ylthio) succinic acid (Irgacor 252LD) were also tested.

Table 5.2 Eight corrosion inhibitors color-coded for experimental identification.

Mfg. Name	Chemical Name	I.D.
CR880	Titanium Dioxide	A
SZP-391	Strontium Zinc Phosphosilicate	B
Butrol 23	Barium Metaborate	C
Nacorr 6401	Zinc Salt of Hydrophobic Sulfonic Acid	D
Busan 11-M1	Barium Metaborate Monohydrate	E
Irgacor 252LD	(1-benzothiazol-2-ylthio) Succinic Acid	F
Zinc Phosphate	Zinc Phosphate	G
CW-491	Calcium Phosphosilicate	H

Test Substrates

Chromated and untreated aluminum (Al2024T3) along with phosphated steel (CRS1008) were used as substrates for corrosion studies. CRS 1008 panels were used for impact resistance. Three panels each, of CRS 1008, chromated AL-2024-T3, and untreated AL-2024-T3, were coated for SO₂ testing and salt fog tests. Aluminium test substrates were purchased from Q-Panel Lab Products and Act Laboratories supplied the steel panels.

Melt Compounding and Powder Grinding

Raw materials were dry blended in a small coffee grinder. Melt mixing employed the use of a 16 mm twin-screw extruder (lab model PRISM) at 250 rpm with a max barrel temperature of 100 °C. For cooling, the extrudate was drop directly into a dewar of liquid nitrogen. The extrudate was then ground in a hammer mill (Retch ZM-100) using a 200 µm distance sieve to yield an approximate mean particle size of 100 µm. The powder was further classified with a gyrating siever using a 117 µm screen.

Coating Preparation

Prior to coating, test substrates were cleaned with a MEK wipe. All powders were applied in an ETI Flexicoat[®] manual powder coating booth using a Nordson SureCoat[®] cup gun with an applied voltage of 70 kV, application pressure of 30 psi, and rinse rate setting of 20 psi. Curing was performed in a Blue-M convection oven at 120 °C for 30 min. For each panel, mean coating thickness and standard deviation was monitored based on 6 measurements using an ElektroPhysik Minitest 4100. After curing, panels were held at ambient conditions for a minimum of 24 hours before testing.

Property Evaluation

SO₂ and salt fog corrosion tests were performed using standard ASTM test methods G85 and B117, respectively, on both steel and aluminum substrates. For 2000 hrs of salt fog testing, any undercutting from the edge of the scribe on the coating is reported as failure. For SO₂ testing, performance is reported as creep after 500 hours of exposure rated on ASTM 1654 scale seen in Table 5.3. For this effort, a rating of 7 is considered failure; this corresponds to an undercutting from the edge of the scribe greater than 1/16”.

Table 5.3 ASTM D1654 rating scale for corrosion undercutting from sample scribe.

Inches	Rating
0	10
0 to 1/64	9
1/64 to 1/32	8
1/32 to 1/16	7
1/16 to 1/8	6
1/8 to 3/16	5
3/16 to 1/4	4
1/4 to 3/8	3
3/8 to 1/2	2
1/2 to 5/8	1

Adhesion testing was performed using a Gardner crosshatch knife and Permacel[®] tape in accordance with ASTM D3359. Direct impact strength was tested in accordance with ASTM D5420 using a Gardner impact tester on CRS 1008 .032” thick steel panels. Pencil hardness was assessed following ASTM D3363. Solvent resistance was determined using the MEK double rub test, ASTM D5402, with failure reported at substrate read-through.

Results and Discussion

Corrosion Performance

No catalysts were added to the formulations used in this work to minimize interactions with the corrosion inhibitors; work reported elsewhere has shown that certain corrosion inhibitor/catalyst combinations can either positively or negatively effect reaction kinetics.²⁴ However, at the low cure temperature requirement catalysis of the acid – epoxy reaction is needed to achieve complete conversion. As a compromise, a highly self-catalyzed base resin was used in this study without any additional catalyst. The base resin chosen for this study has been shown to achieve full conversion under the requisite cure schedule of 120 °C – 30 min.

Figure 5.1 illustrates the experimental setup used to evaluate the corrosion performance of 8 corrosion inhibitors on 3 different substrates. The letter and color coding for each corrosion inhibitor corresponds to that shown in Table 5.2. For the coating under development chromated aluminum is the primary substrate. However, untreated aluminum and phosphatized steel are also investigated for expanded applications. Additionally, two alternative resin types are tested with corrosion inhibitor C. Corrosion inhibitors F and C were blended (40/60) into a separate formulation for a total of 11 formulations.

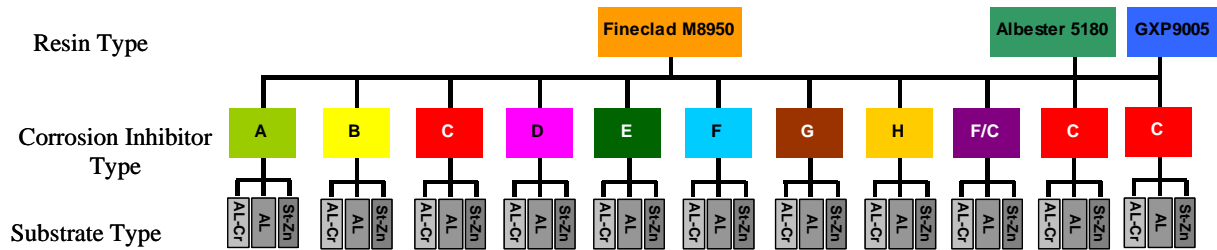

Figure 5.1 Experimental layout to screen 7 corrosion inhibitors on 3 substrates. Letter codes and colors correspond to corrosion inhibitors indicated in Table 5.2.

The SO₂ and salt fog corrosion results are shown in Figures 5.2, 5.3, and 5.4 corresponding to chromated AL2024, untreated AL2024, and phosphatized steel. The results are reported in terms of the undercutting rating defined in Table 5.3 in plots of salt fog versus SO₂ corrosion resistance. To meet requirements salt fog performance must be equal to 10; for SO₂ a value of 7 or greater is required. Overall, independent of inhibitor type, the best corrosion performance is achieved with the chromated aluminum substrates (Figure 5.2). On this substrate, with the exception of the Irgacor 252LD (inhibitor F), all formulations meet specification requirements for salt fog corrosion and exceed requirements for SO₂ corrosion. On untreated aluminum, more differentiation of the corrosion inhibitors is seen (Figure 5.3). Formulations containing Nacor 6401, Irgacor 252LD, Butrol 23, and the 40/60 blend of Irgacor 252LD with Butrol 23 meet specification requirements. Conversely, formulations with Busan 11-M1, Zn₂(PO₄)₂, CW491, SZP391, TiO₂ and Butrol 23 failed, but only in the M8950 base resin. In Albestor 5180 and in GXP9005 the Butrol 23 meet requirements. On the phosphatized steel substrate all formulations fell well short of the required salt fog performance exhibiting greater than .125" undercutting from the scribe (Figure 5.4). For SO₂ testing only three formulations passed: TiO₂, CW491, and Zn₂(PO₄)₂.

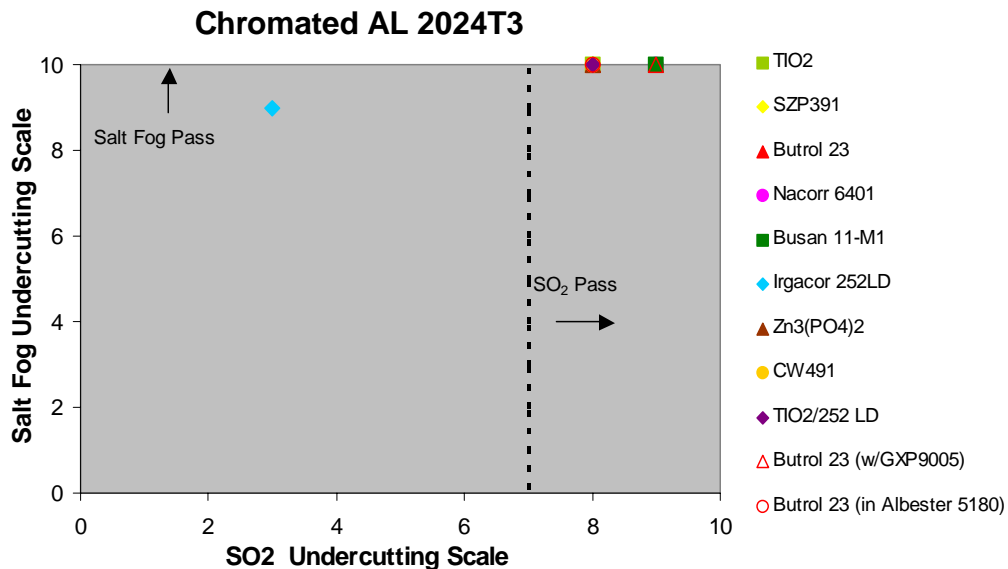

Figure 5.2 Salt fog performance vs. SO₂ performance on chromated aluminum.

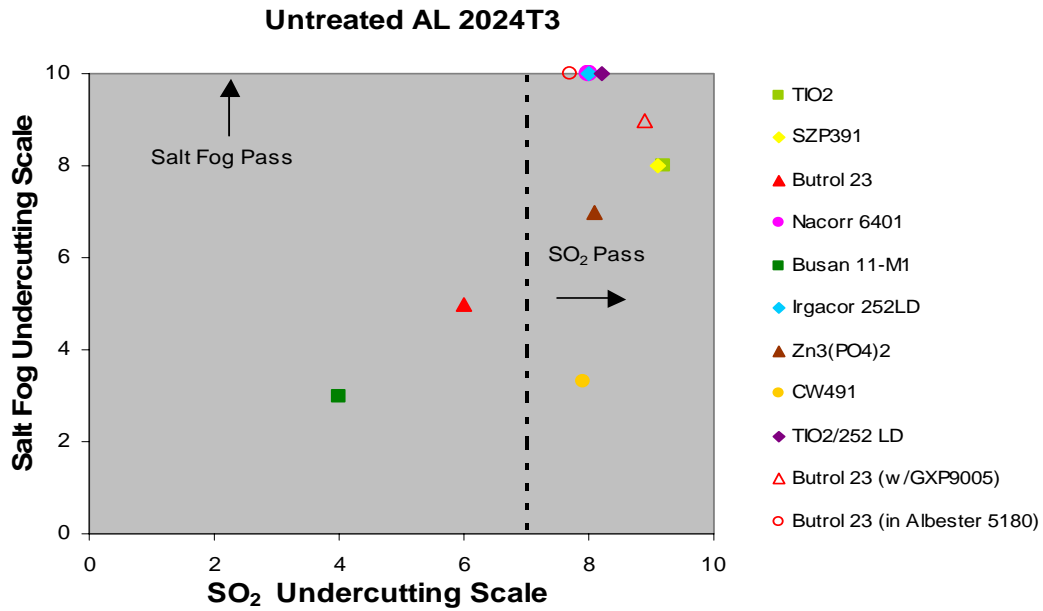

Figure 5.3 Salt fog vs. SO₂ corrosion performance on untreated aluminum.

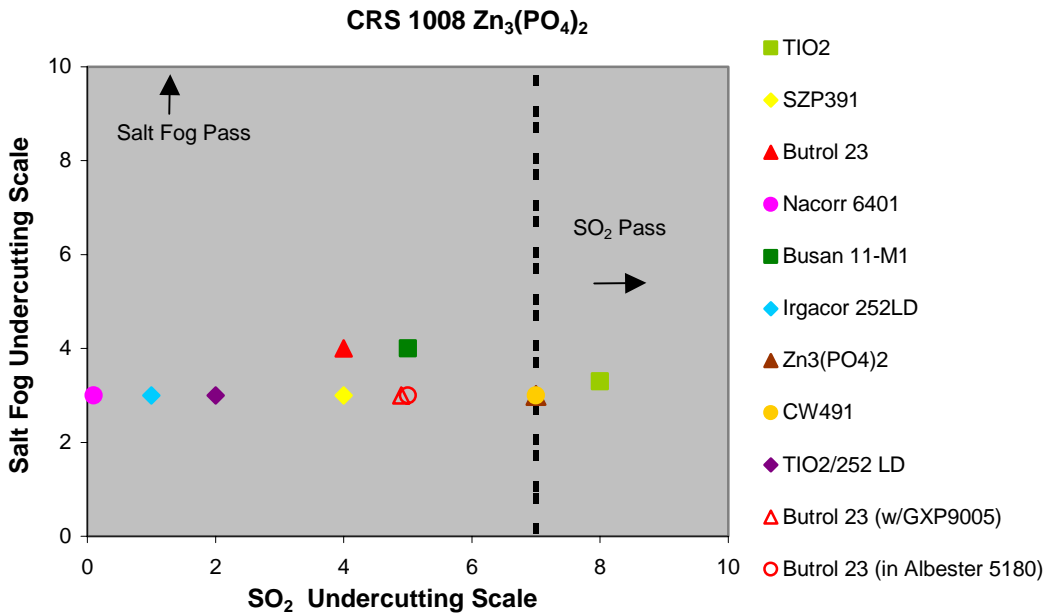

Figure 5.4 Salt fog vs. SO₂ corrosion performance on CRS panel pre-treated with zinc phosphate.

Physical Properties

Multiple corrosion inhibitors have been shown to offer acceptable performance with respect to corrosion requirements. However, these additives can affect other coating attributes. Understanding the overall effect that the inhibitor can have on coating

performance is critical for selection. As a result, each formulation was subjected to critical evaluations including MEK solvent resistance, impact toughness, and adhesion. Tables 5.5 and 5.6 summarize both the corrosion and physical property results. These results are color-coded either red, to indicate failure, or green for meeting specification. Yellow indicates borderline performance.

Five formulations, TIO₂, Butrol 23, Zn₂(PO₄)₂, Busan 11-M1, and CW491 simultaneously offer sufficient corrosion, adhesion, and MEK performance on the aluminum substrate (chromated AL2024T3). The following inhibitors: Nacor 6401, Irgacor 252LD, Irgacor 252LD blended with TIO₂, and Butrol 23 blended with Albester 5180 showed acceptable SO₂ and salt fog corrosion performance but fell short of the specification for adhesion and MEK resistance. No formulation meets requirements for impact, but this is not unexpected owing to omission of catalyst in these formulations.

Table 5.5 Physical performance of corrosion inhibitor formulations.

Resin: Corrosion Inhibitor: Substrate:		Fine-Clad M8950														
		TIO ₂			SZP391			Butrol 23			Nacor 6401			Busan 11-M1		
		AL - Cr	AL	St-Zn	AL - Cr	AL	St-Zn	AL - Cr	AL	St-Zn	AL - Cr	AL	St-Zn	AL - Cr	AL	St-Zn
Salt Fog Corr.	hrs.	2000	2000	1338	2000	2000	1007	2000	2000	2000	2000	2000	672	2000	1671	2000
	Undercutting	10	8	3.3	10	8	3	10	5	4	10	10	3	10	3	4
SO ₂ Corrosion	Undercutting	8	9.2	8	8	9.1	4	8	6	4	9	8	0.1	9	4	5
MEK Resist.	MEK D.R.	170	-	-	170	-	-	138	-	-	10	-	-	118	-	-
Adhesion	Crosshatch	5	-	5	5	-	3	5	-	4	0	-	2	5	-	4
Impact	in-lbs.	-	-	20	-	-	40	-	-	20	-	-	40	-	-	20

Table 5.6 Physical performance of corrosion inhibitor formulations.

Resin: Corrosion Inhibitor: Substrate:		Fine-Clad M-8950												Albester 5180		
		Irgacor 252LD			Zn ₃ (PO ₄) ₂			CW491			TIO ₂ /252 LD			Butrol 23		
		AL-Cr	AL	St-Zn	AL-Cr	AL	St-Zn	AL-Cr	AL	St-Zn	AL-Cr	AL	St-Zn	AL-Cr	AL	St-Zn
Salt Fog Corr.	hrs.	2000	2000	1007	2000	2000	1506	2000	1670	1007	2000	2000	504	2000	2000	1007
	Undercutting	9	10	3	10	7	3	10	3.3	3	10	10	3	10	10	3
SO ₂ Corrosion	Undercutting	3	8	1	8	8.1	7	8	7.9	7	8	8.2	2	8	7.7	5
MEK Resist.	MEK D.R.	20	-	-	200	-	-	165	-	-	20	-	-	20	-	-
Adhesion	Crosshatch	0	-	0	5	-	4.9	5	-	4	0	-	2	5	-	2
Impact	in-lbs.	-	-	0	-	-	20	-	-	40	-	-	0	-	-	0

Conclusions

In this work, seven corrosion inhibitors, each tested separately in a TGIC crosslinked polyester matrix, were found to offer sufficient salt fog and SO₂ corrosion protection on aluminum substrates (chromated AL2024T3). In limited physical testing, 5 of these 7 inhibitors showed particular promise. The performance of these inhibitors was further differentiated on alternative substrates; with untreated aluminum (non-chromated AL2024T3) four inhibitors help meet coating corrosion requirements, but on phosphatized steel (CRS 1008) all corrosion inhibitors failed. This study provides a reference for selecting an appropriate corrosion inhibitor for low temperature cure powder coatings on aluminum (chromated AL2024T3). Simplified model formulations were investigated, however, in final coating systems additional factors will play a role in

down selecting an inhibitor, for example, the potential for inhibitor/catalyst interaction. Also, in the final coating system the inhibitor can be expected to have a considerable effect on gloss, surface quality, and color.

References

1. Miller, E. P.; Taft, D. D. *Fundamentals of Powder Coating*; Society of Manufacturing Engineers: Dearborne, MI, **1974**.
2. Misev, T. A. *Powder Coatings: Chemistry and Technology*; John Wiley & Sons: New York, **1991**.
3. Richart, D. S. *Coating Processes (Powder Technology)*; Howe-Grant, M., Ed.; John Wiley & Sons, Inc.: New York, **1993**; Vol. 6, pp 635-661.
4. Misev, T. A.; van der Linde, R. *Prog. Org. Coat.* **1998**, *34*, 160-168.
5. Farrel, R. *Metal Finishing* **2000**, *98*, 135-141.
6. Armstrong, B. *Powder Coating* **2002**, *Sep*, 60-61.
7. Bergmans, A.; DeCock, C.; Bertens, J.; Kooijmans, P., Shell International Research, *Acid Functional Polyester Resins and Lower Temperature Curable Powder Coating Compositions Comprising Them*, **2000**; European EP 1,006,163.
8. Bergmans, A.; Walravens, M.; DeCock, C.; Riviere, J. *Polymers Paint Colour Journal* **2001**, *Oct*, 17-19.
9. Danick, C. *Low Temperature Crosslinking for Powder Coatings*; Federation of Societies for Coatings Technology International Coatings Conference, New Orleans, LA, **1998**.
10. Johansson, M.; Malmstrom, E.; Jansson, A. *J. Coat. Techn.* **2000**, *72*, 49-54.
11. Laas, H. J.; Meier-Westhues, H. U.; Halpaap, R.; Freudenberg, U.; Klee, H. P., Bayer, *Polyurethane Powder Coating Compositions Which Have a Low Stoving Temperature*, **1998**; U.S. 5,847,044.
12. Malmstrom, E.; Johansson, M.; Jansson, A.; Hult, A. *Novel Concept for Low Temperature Curing Powder Coatings Based on Hyperbranched Polymers*; Proceedings of the International Waterborne, High Solids and Powder Coatings Symposium, New Orleans, LA, **1999**, pp 373-382.
13. McBride, P. J. *J. Oil. Col. Chem. Assoc.* **1982**, *65*, 257-262.
14. Pappas, S. P.; Hill, L. W. *J. Coat. Techn.* **1981**, *53*, 43-50.
15. Pont, J. D. *Further Advances in Low Temperature Cure Polyurethane Powder Coatings*; Proceedings of the International Waterborne, High Solids and Powder Coatings Symposium, New Orleans, LA, **1999**, pp 232-245.
16. Rijkse, K. *Modern Paint & Coatings* **2001**, *April*, 36-39.
17. Roescher, A.; DeRuiter, B. *New Isocyanate-Based Low-Temperature Hardeners for Powder Coatings*; Proceedings XXV FATIPEC Congress, Torino, Italy, **2000**, pp 175-190.
18. Ruth, W. G.; Greth, S. L.; Seelig, C. A.; Schreffler, D. A., Morton International Inc., *Powder Coating of Non-Crystalline and Crystalline Epoxy Resins*, **2000**; U.S. 6,140,430.
19. Sohoni, M.; Figlioti, P. *Developments in Low Temperature Cure: Urethane Powder Curing Agents*; Proceedings of the International Waterborne, High Solids and Powder Coatings Symposium, New Orleans, LA, **1998**, pp 267-280.

20. Subramanian, R.; Sullivan, C. J. *Unsaturated Polyesters in Low Temperature Cure Powder Coatings*; Proceedings of the International Waterborne, High solids and Powder Coatings Symposium, New Orleans, LA, **2001**, pp 381-389.
21. Wenning, A.; Franzmann, G.; Spyrou, E., Degussa AG, *Powder Coating Compositions Comprising Crystalline Urethane Acrylates and Use Thereof*, **2003**; US 0175433 A1.
22. Witzeman, J. S. *Prog. Org. Coat.* **1996**, 27, 269-276.
23. Merfeld, G.; Mordhorst, S.; Koeniger, R.; Acar, A. E.; Molaison, C.; Suriano, J.; Irwin, P.; Warner, R.; Gray, K.; Smith, M.; Kovaleski, K.; Finley, S.; Meredith, D.; Naguy, T.; Spicer, M. *Development of Low Temperature Curing (120 °C) Corrosion Protection Powder Coatings for Thermally Sensitive Substrates*; Proceedings of the International Waterborne, High-Solids, and Powder Coatings Symposium, New Orleans, **2004**.
24. Merfeld, G.; Molaison, C.; Koeniger, R.; Acar, A. E.; Mordhorst, S.; Suriano, J.; Irwin, P.; Warner, R.; Gray, K.; Smith, M.; Kovaleski, K.; Finley, S.; Meredith, D.; Naguy, T.; Spicer, M. *Acid/Epoxy Catalyst Screening for Low Temperature (120°C) Powder Coatings*; Proceedings of the International Waterborne, High-Solids, and Powder Coatings Symposium, New Orleans, **2004**.
25. Hare, C. H. *Protective Coatings: fundamentals of chemistry and composition*; Technology Publishing Co.: Pittsburgh, PA, **1994**.

Chapter 6: Formulation Optimization of a Low Temperature Curing,(120 °C – 30 min), Powder Coating for Temperature Sensitive Substrates

Abstract

A powder coating has been developed that cures within 30 minutes at 120 °C and simultaneously meets all military ground support equipment requirements for exterior durability, toughness, chemical resistance, gloss, and surface quality. In this work, two critical components of the coating formulation, catalyst content and the ratio of resin to crosslinker, were optimized in a 2-factor, 3-level, statistically designed and analyzed experiment. Adhesion, hardness, chemical resistance, and weatherability were shown to meet specification requirements at all levels of catalyst and resin/crosslinker ratios investigated. Surface quality, 60° gloss, and toughness were found to be more strongly responsive to the formulation changes. The best performing powder coating has been identified and down-selected for future qualification testing and field repair evaluation.

This work was supported in part by SERDP contract DACA72-02-C-0025, C. Pellerin, Program Manager.

Introduction

Conventional solvent-borne paints used as corrosion protection coatings give rise to emissions of volatile organic compounds and hazardous air pollutants during their production and application. Powder coatings are an inherently solvent free alternative.¹⁻⁵ There are numerous military and civilian applications that require protective coatings but involve substrates that are made from materials such as low-tempered metal alloys, composites, plastic, or wood that would be structurally compromised by thermal treatments required to cure conventional powder coatings. The need for powder coatings that cure at ever lower temperatures has been presented extensively and much work on their development has been reported in the literature.⁶⁻²²

A specific military need for low temperature curing powder is as a corrosion protection coating for 2024-grade aluminum alloy used in several types of aircraft parts, weapons systems, and ground support equipment. Due to the T3 heat treatment, prolonged exposure to temperatures above 120 °C can compromise the alloy's structural integrity. In addition to meeting the low temperature cure requirement, a powder coating must fulfil performance specifications defined by MIL-PRF-85285D. An abbreviated summary of these criteria is provided in Table 6.1 for ground support equipment, which is the primary target for this research.

Research reported elsewhere describes the successful development of a powder coating that simultaneously fulfils all the requirements shown in Table 6.1.²³ The work reported herein details further optimization of this solution in a designed experiment evaluating formulation stoichiometry and catalysis.

Table 6.1 Target Performance Specifications for 120 °C – 30 min Cure Powder Coating

Property	Test	Units	Specification*	
			LSL	USL
Thickness	Gauge (eddy current, magnetic induction)	mils	2.3	3.2
Adhesion	Crosshatch ASTM D3359-97	ASTM scale	4B	-
Flexibility	Mandrel Bend ASTM D522-93	failure dia. in.	-	0.25
Toughness	GE Impact	% Elongation	5	-
Hardness	Pencil Hardness ASTM D3363	pencil #	2H	-
Chemical Resistance	MIL-H-83282 Fluid Immersion 24 hrs.	delta pencil #	-	2
	MIL-H-5606 Fluid Immersion 24 hrs.	delta pencil #	-	2
	MEK Double Rub ASTM D5402	double rubs	25	
Weathering	Xenon Arc, 500 hrs ASTM G26-96	ΔGloss	-	10
		ΔColor	-	1
Gloss	60° Gloss ASTM D523	gloss units	90	-
Surface Quality [†]	DOI Wavescan, calibrated to PCI standards	standard #	4	-
Corrosion Resistance	Salt Fog, ASTM B117	scribe undercut rating	10	-
	SO2 500 hrs, ASTM G85	scribe undercut rating	7	-

*LSL = lower Spec Limit; USL = Upper Spec Limit

Experimental

Materials and Formulations

Table 6.2 summarizes all the coating components including their function, supplier, and content in the center point formulation. A high flow, super-durable acid functional polyester resin with an equivalent molecular weight of 1600 was combined at three weight ratios, 94:6, 93:7, and 92:8, with triglycidylisocyanurate (TGIC) crosslinker. The catalyst was incorporated at three weight ratios relative to total formulation: 0.55, 0.60, and 0.65 wt.%. A flow additive was used to enhance surface quality by improving flow and leveling and Benzoin was used as a degassing agent. A hindered amine light stabilizer (HALS) was used to provide stability to UV exposure. A corrosion inhibitor was added to improve corrosion resistance. The coating color was matched to a military white federal number 17925.

Table 6.2 Powder coating components and center point formulation.

Function	Content* (wt %)
TGIC	5.3
Polyester Resin	71
Curing Catalyst	0.6
Flow Promoter	1.5
Degassing Agent	0.5
Antioxidant	1.0
Corrosion inhibitor	2.5
Pigment	18.0

*Center point formulation composition

Melt Compounding and Powder Grinding

Coating formulations were dry blended in a Henschel mechanical mixer for 60 sec at 2000 rpm and then melt-mixed on a 50 mm twin-screw extruder (production model Baker Perkins) at 500 rpm with a max barrel temperature of 99 °C. Extrudate was cooled to ambient temperature within 7 sec. using a water-cooled pinch roll with automated kibbling. Powder grinding was performed using an air-classifying mill (ACM-5) followed by sieving through a 140-mesh screen. This process produced powders with a mean size of 40-45 microns (95% < 105 microns) as measured using a Malvern Series 2600 laser analyzer. To investigate the effect on gloss and surface quality, one selected formulation was sieved through a 170-mesh screen to reduce particle size.

Test Substrates

Chromated 2024T3 aluminum was the primary substrate used in this research. Adhesion, hardness, chemical resistance, weathering, surface quality, and corrosion testing were all performed on coatings applied to this substrate. A thinner (.020 in.) version of 2024 without T3 heat treatment was used for GE impact tests, while a slightly thicker .032 version, anodized according to MIL-A-8625 Type I was used for conical flexibility. All test substrates were obtained from Q-panel Lab Products.

Coating Application

Prior to coating, test substrates were cleaned with a MEK wipe. All powders were applied in an ETI Flexicoat[®] manual powder coating booth using a Nordson SureCoat[®] cup gun with an applied voltage of 70 kV, application pressure of 30 psi, and rinse rate setting of 20 psi. Curing was performed in a Blue-M convection oven. For each panel, mean coating thickness and standard deviation was monitored based on 6 measurements using an ElektroPhysik Minitest 4100. After curing, panels were held at ambient conditions for a minimum of 24 hours before testing.

Property Evaluation

Adhesion testing was performed using a Gardner crosshatch knife and Permacel[®] tape in accordance with ASTM D3359. Flexibility testing followed ASTM D522 and was performed with a Gardner mandrel bend tester. GE Impact strength is reported as percent elongation and performed following CTIO lab procedure CCG-LP-016 REV 06. Pencil hardness was assessed following ASTM D3363. Solvent resistance was determined using the MEK double rub test, ASTM D5402, with failure reported at substrate read-through.

For accelerated weathering an Atlas Ci35a Xenon Weather-Ometer[®] was used. To assess performance, color coordinates and gloss were measured as a function of exposure. A Macbeth Colorimeter (Color-Eye 7000A) for color measurements according to ASTM D2244. Gloss was measured at 20° and 60° using a BYK Gardner Tri-Gloss Meter. 20° gloss was measured when the 60° gloss was 70% or greater. The ΔE color change and Δ gloss are reported here after 500 hrs of exposure.

Coating surface quality was determined using a BYK Gardner Wavescan[™] Distinctness of Image (DOI) instrument with the Wd output calibrated relative to Powder Coating

Institute (PCI) surface quality standards using the expression: $PCI = (Wd - 84) / (-7.29)$. Results are reported in PCI units ranging from 1-10, with 10 corresponding to the best quality. In samples where gloss was inadequate to allow use of the Wavescan, visual assessments were made using side-by-side comparison to the surface quality standards.

Hydraulic immersion testing was performed following MIL-PRF-85285D. All test fluids used in this study were used as received. Cured panels were immersed in a Petri dish containing one of two grades of hydraulic fluid, MIL-H-5606 or MIL-H-83282, and then placed in a $66^\circ \pm 3^\circ\text{C}$ equilibrated oven for twenty-four hours. After cleaning, the test specimens were evaluated for blistering, pencil hardness and adhesion. The values for hardness and adhesion were determined relative to untested panels; any change in hardness or adhesion constituted failure.

Results and Discussion

Figure 6.1 is a diagram of the 2-factor 3-level optimization experiment developed for this study. This design builds on previous research wherein specific resin, catalyst, flow additive and pigment level were down selected.²³ This earlier work also showed that an ultra violet light absorber (UVA) was not required. Catalyst level and the crosslinker to resin ratio are the experimental factors, each investigated at three levels. The catalyst was evaluated at 0.55, 0.60, and 0.65 weight percent, while the resin/crosslinker ratio was investigated at 92/8, 93/7, and 94/6. The full factorial design was performed and the center point formulation, catalyst level = 0.60 and cross-linker resin/ratio = 93/7, replicated twice. A total of 11 powder coating formulations were run.

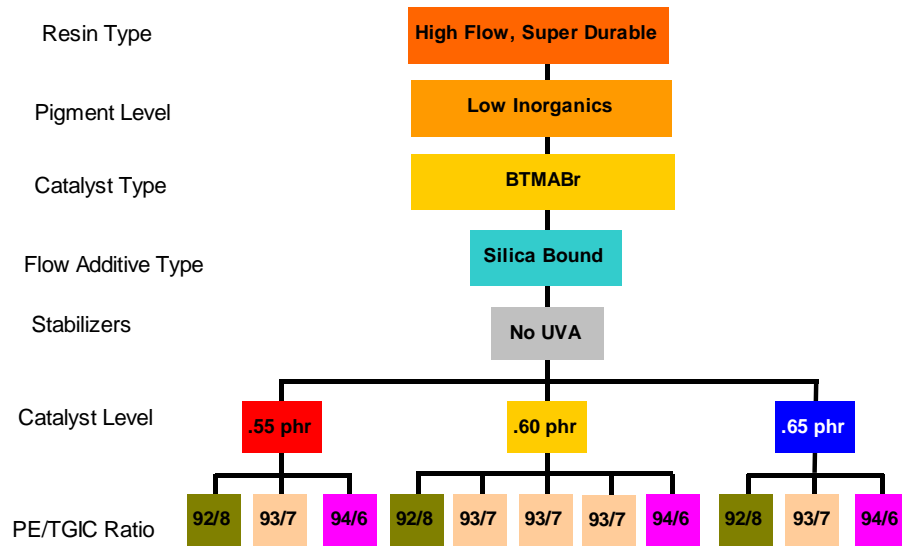

Figure 6.1 Diagram of full factorial optimization experiment. Catalyst level and resin/crosslinker ratio are investigated at three levels each.

The results from the optimization experiment are shown in Table 6.3. This summarizes the formulation performance in terms of adhesion, flexibility, toughness, hardness, chemical resistance, gloss, surface quality, and, for a limited number of samples, weathering. Only corrosion resistance was not assessed here; evaluation of earlier generation coatings identified no failures. Green fill indicates passing performance and

red signifies failure relative to the specifications in Table 6.1. Overall, the coatings perform well but only the center point meets all the requirements. Higher levels of catalyzation compromise gloss while lower levels suffer in toughness. At the center catalyst level, off center ratios of resin to crosslinker, both higher and lower, negatively affect toughness and gloss, respectively.

Table 6.3 Performance scorecard.

Property	Test		Catalyst Level:									Stoichiometry:		
			0.55	0.55	0.55	0.60	0.60	0.60	0.60	0.60	0.60	0.65	0.65	0.65
			92/8	93/7	94/6	92/8	93/7	93/7	93/7	93/7	94/6	92/8	93/7	94/6
Adhesion	Crosshatch	4B	5B	5B	5B	5B	5B	5B	5B	5B	5B	5B	5B	5B
Flexibility	Mandrel Bend	1/4"	Pass	Pass	Pass	Pass	Pass	Pass	Pass	Pass	Fail	Pass	Pass	Fail
Toughness	G.E. Impact--Support	5%	4	5	4	5	5	5	5	5	3	5	5	5
Hardness	Pencil	2H	3H	2H	2H	3H	3H	2H	2H	2H	2H	3H	H	3H
Chem Resist.	MEK DR	25	82	109	79	144	117	104	115	84	119	94	92	
	Hydrc. Fld. Mil-H-5606	0	3H	2H	2H	3H	3H	2H	2H	2H	3H	H	3H	
	Hydrc. Fld. Mil-H-83282	0	3H	2H	2H	3H	3H	2H	2H	2H	3H	H	3H	
Weathering	Xenon-arc (500 hrs)	ΔGloss	10	-	2.5	-	-	0.0	0.9	1.5	-	-	-	-
		ΔColor	1	-	0.2	-	-	0.1	0.8	0.6	-	-	-	-
Gloss	60° Gloss	90	88	89	90	83	90	89	90	87	87	88	87	
Surface Quality	DOI	4	4	4	5	4	4	4	4	4	3	4	3	

In more detailed analysis, all formulations meet requirements for adhesion, hardness, chemical resistance, and weatherability. This proves robustness relative to the catalyst levels and PE/TGIC ratios considered. Flexibility, toughness, gloss, and surface quality exhibit sensitivity to catalyst level and PE/TGIC ratio. The highest catalyst level (0.65wt%) consistently showed a 2-3% reduction in gloss and two surface quality failures of 1 PCI unit. These deficiencies may be attributed to decreased flow caused by an over-catalyzed system. Two of the three formulations containing the lowest catalyst level (0.55wt%) exhibited a 1-2% deficiency in 60° gloss and a 1% deficiency in impact toughness. No formulation blended at the 92/8 PE/TGIC ratio met 60° gloss requirements and two of the three 94/6 formulations failed flexibility. Based on these results the center point formulation containing the 93/7 stoichiometry and 0.60 wt% catalyst provides a robust solution. Statistical results reported below further validate this conclusion.

Statistical Analysis

In the preceding analysis, surface quality, 60° gloss, and toughness were shown to be most sensitive to variations in catalyst and stoichiometry. A complete statistical analysis was performed on these three responses to validate the optimal formulation identified in Table 6.2. Within the narrow ranges investigated, toughness was found to be statistically insensitive to catalyst and stoichiometry. In previous work, larger adjustments to these factors were shown to adversely affect toughness. Surface quality and gloss were more significantly affected by the variable changes; model P-values of 0.0003 and 0.0239, respectively, indicate this statistically. However, the noise in the response data is nearly as large or larger than the changes induced by the factor levels. Specifically for gloss, a maximum difference of about 1% was recorded in the mean values while the group standard deviation was 2.9% of the average. For surface quality, the analogous comparison is approximately 20% to 14%. For this reason, it was not possible to fit predictive models to the data. While this precludes any further statistical optimization it does verify the robustness of this formulation system. Thus, within the perturbation sizes

considered here, changes to the coating formulation are not expected to adversely affect performance and the coating should reliably meet specifications.

Particle Size Reduction

The optimization performed in the preceding sections focused on factors relating to coating chemistry. How the powder is prepared and in particular how finely the powder is ground can also strongly impact gloss and surface quality as discussed in chapter 4. While the specifications for surface quality and gloss were met, there is room for improvement relative to the current paint system. Up to this point, all powder formulations have been sieved through a 140-mesh screen. To assess the effect of particle size reduction, a replicate from the center point formulation (.60 wt. % catalyst & 93/7 polyester/TGIC ratio) was sieved through a finer 170-mesh screen. This brought a 4% increase in the 60° gloss as shown in Figure 6.2 and a 25% improvement in surface quality.

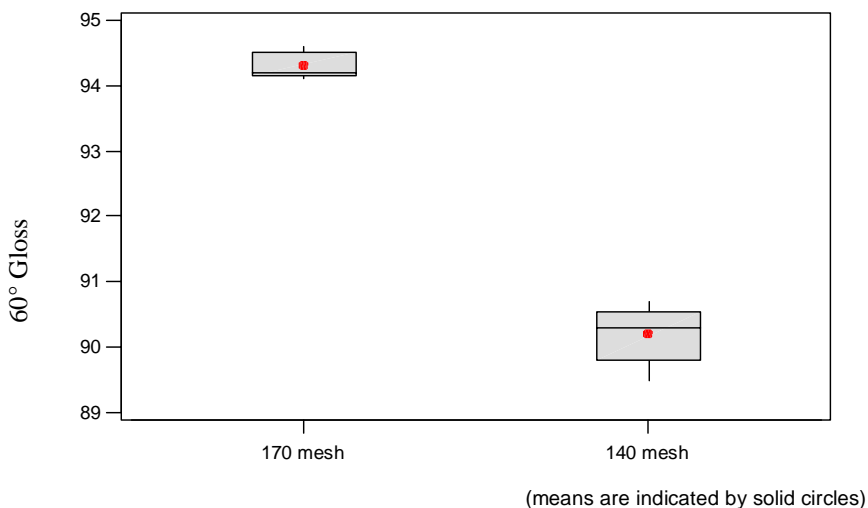

Figure 6.2 60° Gloss improvement shown with finer, 170-mesh screen.

Conclusions

A low temperature cure powder coating has been developed that cures at 120 °C within 30 minutes and meets all required screening performance properties for military ground support equipment. Catalyst content and the ratio of resin to crosslinker were explored as critical factors in a designed optimization experiment. The best physical properties including gloss, surface quality, and toughness were most consistently achieved with a catalyst level of 0.60 wt % and a resin/crosslinker wt ratio of 93/7. Statistical analysis could not further improve upon of this result but rather confirmed the robustness of the solution within the factor levels considered. As part of this work, opportunity was shown to further enhance gloss by 4% and surface quality by 25% by reducing particle size from 42 to 31 microns. Future work will make use of this optimized formulation in qualification testing and field repair evaluation.

Reference

1. Miller, E. P.; Taft, D. D. *Fundamentals of Powder Coating*; Society of Manufacturing Engineers: Dearborne, MI, **1974**.
2. Misev, T. A. *Powder Coatings: Chemistry and Technology*; John Wiley & Sons: New York, **1991**.
3. Richart, D. S. *Coating Processes (Powder Technology)*; Howe-Grant, M., Ed.; John Wiley & Sons, Inc.: New York, **1993**; Vol. 6, pp 635-661.
4. Misev, T. A.; van der Linde, R. *Prog. Org. Coat.* **1998**, *34*, 160-168.
5. Farrel, R. *Metal Finishing* **2000**, *98*, 135-141.
6. Armstrong, B. *Powder Coating* **2002**, *Sep*, 60-61.
7. Bergmans, A.; DeCock, C.; Bertens, J.; Kooijmans, P., Shell International Research, *Acid Functional Polyester Resins and Lower Temperature Curable Powder Coating Compositions Comprising Them*, **2000**; European EP 1,006,163.
8. Bergmans, A.; Walravens, M.; DeCock, C.; Riviere, J. *Polymers Paint Colour Journal* **2001**, *Oct*, 17-19.
9. Danick, C. *Low Temperature Crosslinking for Powder Coatings*; Federation of Societies for Coatings Technology International Coatings Conference, New Orleans, LA, **1998**.
10. Johansson, M.; Malmstrom, E.; Jansson, A. *J. Coat. Techn.* **2000**, *72*, 49-54.
11. Laas, H. J.; Meier-Westhues, H. U.; Halpaap, R.; Freudenberg, U.; Klee, H. P., Bayer, *Polyurethane Powder Coating Compositions Which Have a Low Stoving Temperature*, **1998**; U.S. 5,847,044.
12. Malmstrom, E.; Johansson, M.; Jansson, A.; Hult, A. *Novel Concept for Low Temperature Curing Powder Coatings Based on Hyperbranched Polymers*; Proceedings of the International Waterborne, High Solids and Powder Coatings Symposium, New Orleans, LA, **1999**, pp 373-382.
13. McBride, P. J. *J. Oil. Col. Chem. Assoc.* **1982**, *65*, 257-262.
14. Pappas, S. P.; Hill, L. W. *J. Coat. Techn.* **1981**, *53*, 43-50.
15. Pont, J. D. *Further Advances in Low Temperature Cure Polyurethane Powder Coatings*; Proceedings of the International Waterborne, High Solids and Powder Coatings Symposium, New Orleans, LA, **1999**, pp 232-245.
16. Rijkse, K. *Modern Paint & Coatings* **2001**, *April*, 36-39.
17. Roescher, A.; DeRuiter, B. *New Isocyanate-Based Low-Temperature Hardeners for Powder Coatings*; Proceedings XXV FATIPEC Congress, Torino, Italy, **2000**, pp 175-190.
18. Ruth, W. G.; Greth, S. L.; Seelig, C. A.; Schreffler, D. A., Morton International Inc., *Powder Coating of Non-Crystalline and Crystalline Epoxy Resins*, **2000**; U.S. 6,140,430.
19. Sohoni, M.; Figlioti, P. *Developments in Low Temperature Cure: Urethane Powder Curing Agents*; Proceedings of the International Waterborne, High Solids and Powder Coatings Symposium, New Orleans, LA, **1998**, pp 267-280.
20. Subramanian, R.; Sullivan, C. J. *Unsaturated Polyesters in Low Temperature Cure Powder Coatings*; Proceedings of the International Waterborne, High solids and Powder Coatings Symposium, New Orleans, LA, **2001**, pp 381-389.
21. Wenning, A.; Franzmann, G.; Spyrou, E., Degussa AG, *Powder Coating Compositions Comprising Crystalline Urethane Acrylates and Use Thereof*, **2003**; US 0175433 A1.
22. Witzeman, J. S. *Prog. Org. Coat.* **1996**, *27*, 269-276.

Chapter 7: Qualification and Field Repair Testing of a Low Temperature Curing, 120 °C – 30 min, Powder Coating

Abstract

As part of expanded qualification testing, the chemical strippability of the developmental coating was confirmed and the cleanability requirement was met using a selection of approved Qualified Product Listing (QPL) cleaners. The color target and stability to heat treatment were also verified. Additionally, refinement of the coating’s flow additive system and augmentation of the crosslinker with a functional polyacrylate were shown to bring higher levels of cleanability and improvements in surface quality. A complete field repair evaluation was performed and acceptable adhesion and compatibility with existing patch systems was demonstrated. Lastly, cyclic and filiform corrosion resistance was studied and, per the request of military partners, UV-B weathering testing was conducted.

Introduction

The development, and optimization of a low temperature cure powder coating for military ground support equipment is reported in Chapter 6. To converge to this solution over 100 experimental powder coating formulations were subjected to the screening tests shown in Table 7.1. The best candidate coating that meets all these criteria has been down selected and in this work is subjected to the expanded qualification tests shown in Table 7.2. Alternative formulations were prepared and investigated to target improvements in cleanability. Selected modifications to the candidate formulation were also investigated to further refine coating surface quality and cleanability.

Table 7.1 Screening performance specifications

Property	Test	Units	Specification*	
			LSL	USL
Thickness	Gauge (eddy current, magnetic induction)	mils	2.3	3.2
Adhesion	Crosshatch ASTM D3359-97	ASTM scale	4B	-
Flexibility	Mandrel Bend ASTM D522-93	failure dia. in.	-	0.25
Toughness	GE Impact	% Elongation	5	-
Hardness	Pencil Hardness ASTM D3363	pencil #	2H	-
Chemical Resistance	MIL-H-83282 Fluid Immersion 24 hrs.	delta pencil #	-	2
	MIL-H-5606 Fluid Immersion 24 hrs.	delta pencil #	-	2
	MEK Double Rub ASTM D5402	double rubs	25	
Weathering	Xenon Arc, 500 hrs ASTM G26-96	ΔGloss	-	10
		ΔColor	-	1
Gloss	60° Gloss ASTM D523	gloss units	90	-
Surface Quality[†]	DOI Wavescan, calibrated to PCI standards	standard #	4	-
Corrosion Resistance	Salt Fog, ASTM B117	scribe undercut rating	10	-
	SO2 500 hrs, ASTM G85	scribe undercut rating	7	-

*LSL = lower Spec Limit; USL = Upper Spec Limit

Table 7.2 Qualification performance specifications

Property	Test	Units	Specification	
			LSL	USL
Corrosion Resistance	Cyclic on scribed steel GM 9540P	cycles to failure	80	-
	Filiform ASTM 2803-93	in.	-	0.25
Weathering*	QUV-B Weathering (500 hrs)	Δ Gloss (60°)	-	-
		Δ E	-	-
Cleanability	Mil-PRF-85285D	%	75	-
Strippability	Mil-PRF-85285D	%	90	-
Heat Resistance	1 Hr. @ 250 °F	Δ E	-	1
Reparability	Patti Adhesion	psi	-	-
	DI Water Immersion	Δ Pencil#	-	2
	Hydraulic Fluid Mil-H-5606	Δ Pencil#	-	2
	Hydraulic Fluid Mil-H-83282	Δ Pencil#	-	2
Color	Military White (17925)	Δ E	-	2

*No specification given for these properties

Methods, Results, and Discussion

Coatings were formulated as described in the experimental section of Chapter 6.

Coating Preparation

Prior to coating, test substrates were cleaned with a MEK wipe. All powders were applied in an ETI Flexicoat[®] manual powder coating booth using a Nordson SureCoat[®] cup gun with an applied voltage of 70 kV, application pressure of 30 psi, and rinse rate setting of 20 psi. Curing was performed in a Blue-M convection oven at 120 °C for 30 minutes. On thicker substrates, the time lag to reach 120 °C was determined and the actual cure time adjusted accordingly. For each panel, mean coating thickness and standard deviation was evaluated based on 6 measurements using an Electrophysik Minitest 4100. All tested coatings targeted a thickness specification between 2.3-3.2 mils. After curing, panels were held at ambient conditions for a minimum of 24 hours before testing.

Corrosion Testing

Cyclic corrosion testing was performed at NavAir (Patuxent River, MD) following GM9540P with a test duration of 80 cycles. Steel test panels (6" x 4" x .190") were cadmium plated per AMS-QQ-P-416 (type I, class 3, .0002" thick). The panels were obtained from Specialized Metals (Coral Springs, FL) and pretreated at Millcreek Metal Finishing, Inc. (Erie, PA). The salt solution consists of 0.9% sodium chloride, 0.1% calcium chloride, and 0.25% sodium bicarbonate.

At the time of this report, cyclic corrosion had reached 65 of the 80 required cycles; the completed test data should be available mid 2005 from the partners at NavAir. Three of the four replicate samples tested were suffering uplifting from the scribe with one sample showing passing performance. The steel substrates used in this test were provided by private industry and may not be representative of military use. As part of follow-up

work, such as the Environmental Security Technology Certification Program ESTCP, it would be recommended to perform this test on military supplied cadmium plated 4340 steel.

Filiform corrosion was also tested at NavAir on Alclad pretreated 6"x4"x.032" AL2024T3 panels supplied by Q-Panel Lab Products (Cleveland, OH). Filiform corrosion was evaluated in a two-step process. Panels were first exposed to a hydrochloric gas for 1 hour and then immersed in glycerin and water for 30 days. Filiform testing is currently in progress and projected to be completed by mid 2005. Final filiform and cyclic corrosion results will be available from NavAir (Patuxent River, MD. Contact: Dr. Kevin Kovaleski 301-342-8049).

Q-UVB Weathering

UVB testing, following ASTM G154 was carried out in a UVB weathering hood utilizing UVB-313 lamps. The black panel temperature was set to 65 °C and the weathering cycle consisted of 16 hrs of light followed by 8 hrs of dark with condensation at 55 °C. Samples were prepared on 6" x 4" x .032" chromate pretreated (per MIL-C-5541-1A) AL2024T3 panels supplied by Q-Panel Lab Products. No specification has been determined for this test and it is not listed in the MIL-PRF-85285 test specifications. Testing was carried out to 1000 hrs with both gloss and color recorded as a function of exposure. Color and gloss results are shown in Figures 7.1 and 7.2, respectively. Three replicates of the incumbent paint technology conforming to MIL-PRF-85285 were included in the studied and are referred to as paint replicates (Paint Rep) 1-3. Five replicates of the candidate powder were also tested and referred to as powder replicates (Powder Rep) 1-5.

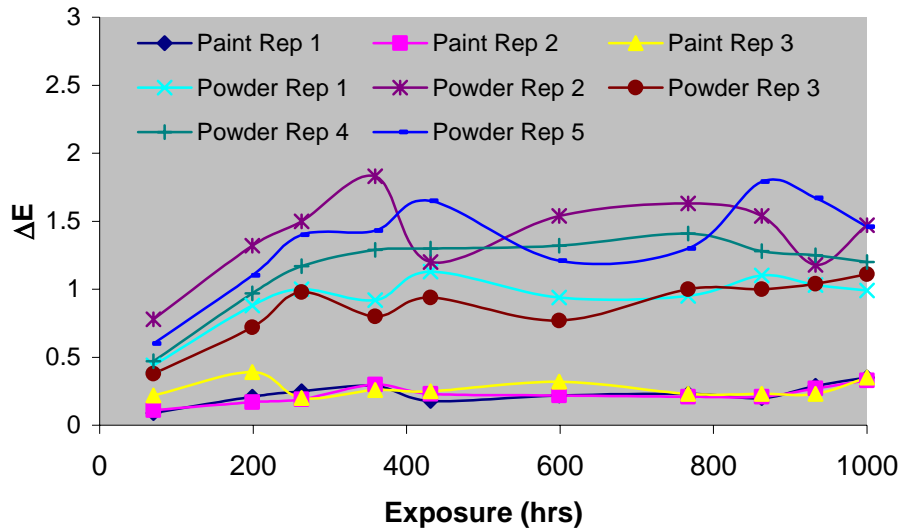

Figure 7.1 Color change (ΔE) results for UVB testing

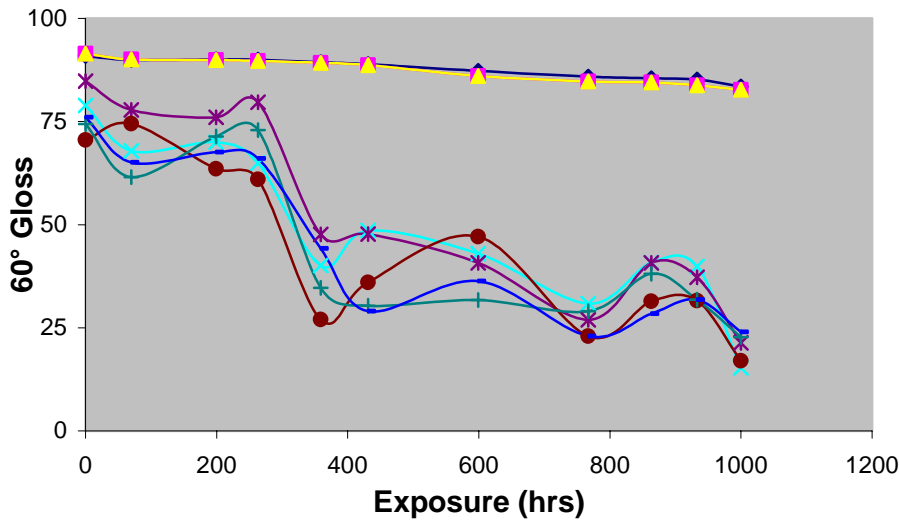

Figure 7.2 60° Gloss results for UVB testing.

Cleanability

This test determines the percent cleanability that can be achieved on a coated surface using cleaners approved by the military. Testing procedures conformed to MIL-PRF-85285D and the cleaners used meet MIL-PRF-85570 Type II standards. The five cleaners tested are listed in Table 7.3 along with the cleaner to water mix ratio used.

Table 7.3 QPL approved cleaners used in this work

Cleaner	Supplier	Ratio (Cleaner: Water)
MA 102-PRF	JAD Chemical Co.	1:4
MA 102-PRF Spray	JAD Chemical Co.	1:8
Penair C5572	Penetone Corp.	1:4
NAV-II H812	ZEP Manufacturing Co.	1:4
Turco 660	Eldorado Chemical Co, Inc.	1:5

The procedure for cleanability is listed below:

1. Pre-clean sample and then hold at 49 °C for a minimum of 18 hours.
2. Obtain initial L* value (L_{initial}) (Macbeth colorimeter).
3. Apply artificial soil to the panel and bake for 1 hour at 105 °C.
4. Measure soiled L* value (L_{soiled}).
5. Clean soiled panel and measure final L* value (L_{cleaned}).
6. Calculate percent cleanability as:

$$(L^*_{cleaned} - L^*_{soiled}) / (L^*_{initial} - L^*_{soiled}) \times 100.$$

Initial cleanability testing was performed using Turco 660 as recommended by the AFRL at a 1:10 concentration. This cleaner proved to be insufficient for cleaning the powder coating to the required 75% specification, however, failure was only seen in the highest soil soak temperature as shown in Figure 7.3.

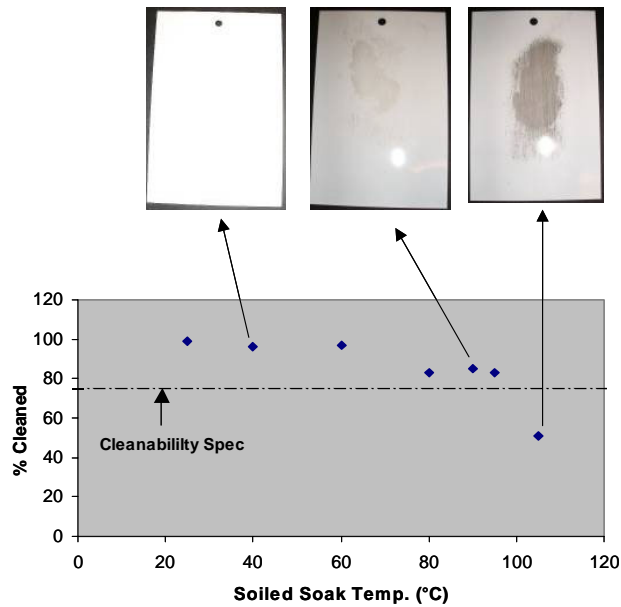

Figure 7.3 Cleanability as a function of soil soak temperature with Turco 660

To resolve this cleanability deficiency alternative Qualified Product Listing (QPL) approved cleaners, shown in Table 7.3, were tested. Additionally, minor adjustments to the powder coating, including the use of alternative crosslinkers and flow additives, were made to target improved cleanability and surface quality. These formulations are identified in Table 7.4. For reference, the baseline candidate coating has been replicated and is included in Table 7.4 as formulation A. In total, five cleaners were tested on 6 formulations.

Table 7.4 Formulation refinements to enhance cleanability and surface quality

Formulation Component	A	B	C	D	E	F
Crosslinker A	5.3	3.6	5.4	3.6	5.3	3.6
Crosslinker B	-	5.4	-	5.4	-	5.4
Polyester Resin	71.0	67.3	52.0	48.3	62.2	58.5
Catalyst	0.6	0.6	0.6	0.6	0.6	0.6
Flow Promoter A	1.5	1.5	-	-	-	-
Flow Promoter B	-	-	20.5	20.5	-	-
Flow Promoter C	-	-	-	-	10.3	10.3
Additives and Pigments	22.0	22.0	22.0	22.0	22.0	22.0

This study revealed multiple cleaners and formulations that, together, meet the 75% cleanability requirement. A complete screening of physical properties was performed on all new formulations. The results are shown in Table 7.5 and are color-coded green for passing, red for failure, and yellow for borderline. More than one cleaner was identified for the formulation (Formula A) originally down selected for qualification testing. Additionally, alternative formulations developed as part of this work show advantages in surface quality while maintaining requisite physical properties. Most notably, formulation B gives the best overall performance.

Table 7.5 Scorecard of Table 7.4 formulation performance. Cleaners and formulations are color coded to correspond with the legend in Tables 7.3 and 7.4.

Property	Test	Spec	A	B	C	D	E	F
Adhesion	Crosshatch	4B	5B	5B	5B	5B	5B	5B
Flexibility	Mandrel Bend	1/4"	Pass	Pass	Fail	Fail	Pass	Pass
Toughness	G.E. Impact--Support	5%	5	5	2	1	10	5
Hardness	Pencil	2H	2H	2H	3H	3H	2H	2H
Chem Resist.	MEK DR	25	78	40	58	81	57	88
	Hydrc. Fld. Mil-H-5606	0	2H	2H	2H	2H	2H	2H
	Hydrc. Fld. Mil-H-83282	0	2H	2H	3H	3H	2H	2H
Cleanability	MA 102-PRF	75	87	89	88	90	86	89
	MA 102-PRF Spray	75	75	79	86	91	77	86
	Penair	75	87	89	85	92	83	88
	NAV-II	75	81	84	90	94	85	88
	Turco A660	75	67	78	86	85	79	85
Gloss	60° Gloss	90	92	93	95	94	89	90
Surface Quality	DOI	4	4	5	4	2	4	3

Strippability

Strippability testing procedures follow MIL-R-81294D. Powder coated test panels were first aged at a 66 °C +/- 3° for 7 days. Prior to testing, 5mm of the perimeter on each test panel was sealed with Parafilm® tape. Each test panel was then fixtured on a rack at 60° from horizontal. Cee-B-R-256 stripper (McGean-Rohco, Inc; containing 40% methylene chloride, 15% phenol and 1% sodium chromate) was poured across the top edge of each test panel as shown in Figure 4 such that the entire surface was covered within 15-seconds. The stripper was allowed to sit 1 hour and then the loose paint was removed from the panel with a spatula and scrubbing with a stiff bristle brush under running water. Visual inspection was used to estimate the exposed substrate surface. The powder coating was found to be 100% strippable as shown in Figure 7.4.

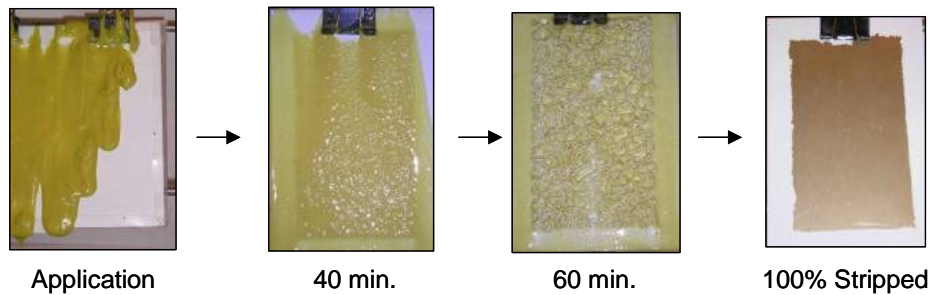

Figure 7.4 Application and stripping performance as a function of time

Heat Resistance

Heat resistance testing was performed in accordance with MIL-PRF-85285D. In this test, a powder-coated panel is subjected to 121 °C for 60 minutes. The change in color is recorded by taking color measurements before and after heat exposure.

The powder candidate meets specification with respect to heat resistance with no detectable change in ΔE.

Field Reparability – This section was performed and written by Chris Joseph and colleagues of the Coatings Technology Integration Office at Wright Patterson AFB.

Field repair determines the compatibility of the powder coating with current patch systems. The reparability testing consisted of the following tests:

1. PATTI Adhesion
2. DI Water Immersion – Modified “X” adhesion 24 hours at room temperature
3. Hydraulic Fluid Immersion – pencil hardness and crosshatch adhesion
 - MIL-H-5606 – 24 Hours @66°C (150°F).
 - MIL-H-83282 – 24 Hours @ 66°C.

The University of Dayton Research Institute (UDRI) at Wright Patterson Air Force Base (WPAFB) in Dayton, OH carried out the field repair testing.

Field Reparability: Procedures, Substrates, and Materials

Aluminum (Al2024T3) test panels having a dimension of 12” x 12” x .032” were given an Alodine 1200s pretreatment at WPAFB. These panels were powder coated at GE Global Research in Niskayuna, NY within 48 hrs of pretreatment, and then sent back to WPAFB where they were artificially aged for 500 hrs using Xenon Arc under the following conditions:

- Irradiance: 0.35 w/m²
- Black panel temperature: 63 °C +/-2.5 °C
- Exposure Cycle: 102 minutes of light followed by 18 minutes of light and water spray

The coating systems tested are shown in Table 7.6. Test panels were pretreated with the required chromated conversion coating, Alodine 1200S. An alternative non-chromate system, referred to as Prekote, was also tested. For patching, two primers were tested, Deft 02-Y-40 and EWDOY48, along with two topcoats, Deft 99-W-009 and Deft 03-W-127.

Table 7.6 Coating and patch systems used for field repair

System	Coating System		Patch System	
	Pretreatment	Topcoat	Primer	Topcoat
A	Alodine 1200S	GE Powder	Deft 02-Y-40	Deft 99-W-009
B	Prekote	GE Powder	Deft 02-Y-40	Deft 99-W-009
C	Alodine 1200S	GE Powder	EWDOY48	Deft 99-W-009
D	Prekote	GE Powder	EWDOY48	Deft 99-W-009
E	Alodine 1200S	GE Powder	Deft 02-Y-40	Deft 03-W-127

The test coupons were prepared in the following manner (see Figure 7.5):

1. The top 3 inches of the coupons that were used for the crosshatch adhesion test, ASTM D 3359-02, were scuff sanded with 80 grit sandpaper to abrade the surface of the powder coating.
2. The middle 6 inches of the coupons were heavily sanded to remove all gloss and lightly taper the coating thickness to bare metal.
3. The bottom 3 inches of the coupons was sanded to bare metal.

4. The top 4 inches of the coupons used for PATTI testing were scuff sanded with 80 grit sandpaper to abrade the surface of the powder coating.
5. The middle 4 inches were heavily sanded to remove all gloss and lightly taper the coating thickness to bare metal.
6. The bottom 4 inches of the coupons was sanded to bare metal.
7. The bare metal areas were readied for painting:
 - The coupons that were conversion coated with Alodine 1200S were re-conversion coated with an Alodine 1132 Touch and Prep Pen.
 - The coupons that were pretreated with Pantheon Prekote were re-treated with Pantheon Prekote.

The coupons were dried overnight, and then the liquid primer was applied per manufacturer's recommendation followed by the application of the liquid topcoat. The coupons were then cured for 14 days at 77°F/50% relative humidity in a Thermatron cabinet.

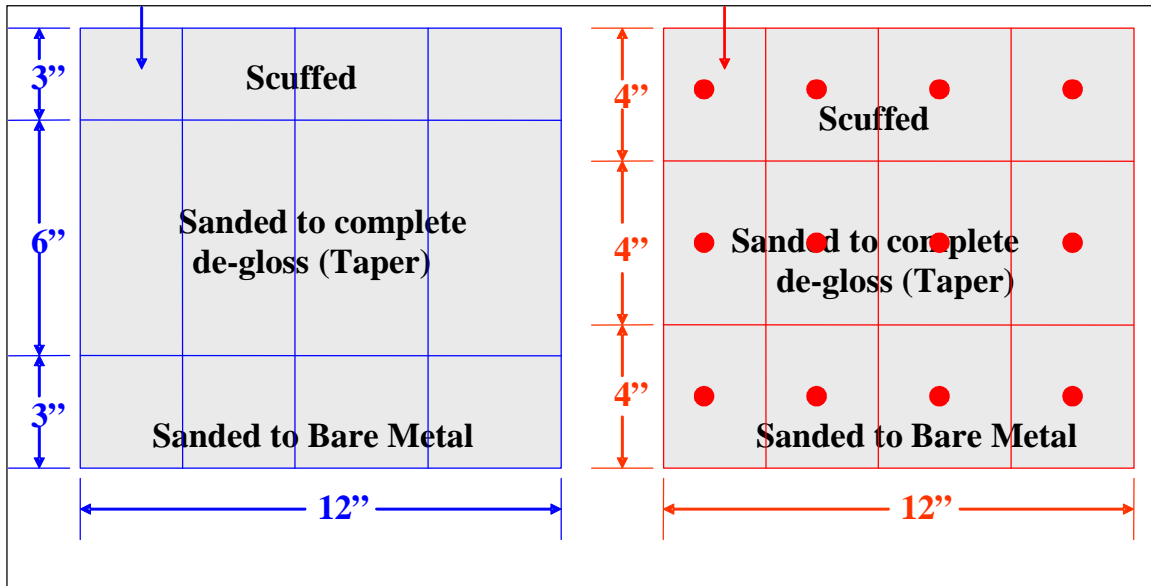

Figure 7.5 Coupon preparation diagram

Field Reparability: PATTI Adhesion Testing

Adhesion testing followed ASTM D 4541 using a Pneumatic Adhesion Tensile Testing Instrument (PATTI). Deviations from the ASTM follow UDRI/CTIO Laboratory Procedure CCG-LP-046, Tensile Adhesion. Equipment required for this test included the following:

- SEMicro Pneumatic Adhesion Tensile Testing Instrument described in annex A4 of ASTM D 4541
- F-8 piston assembly for the PATTI tester
- Laboratory oven to cure adhesive (capable of 60°C)
- Standard needle-nose pliers

The required test supplies were:

- Epoxy adhesive suitable for adhering pull-off studs to the test coating. Reference ASTM D 4541

- Flat ceramic tiles; 4” x 4”
- Talcum powder

Each test coupon was sheared to the proper size and a ½” ring was scribed through the coating to the substrate; the ring area was used to adhere the stud to the coupon. The sheared coupons were adhered to the ceramic tiles using an epoxy adhesive to prevent distortion from the substrate, which is 0.032” thick. The studs were then glued to the coupons and baked at 60°C for 24 hours. The pressure required to pull the stud from the coupon was recorded and the type of failure was also recorded.

The failure mechanism reported was determined by which interface accounted for a majority (>50%) of the failure; data are summarized in Table 7.7.

Table 7.7 Patti adhesion results.

System	A	B	C	D	E
PATTI Adhesion ¹	Scuff				
Failure Mechanism	C,C,C	C,C,C	E,E,E	E,E,E	C,C,C
Pressure Required	403, 321, 158	933, 811, 688	1668, 1668, 1464	1709, 1790, 444	1709, 2199, 1995
	Taper				
Failure Mechanism	C,C,C	C,C,C	E,B,A ²	A,A,A	C,C,C
Pressure Required	933, 933, 1097	852, 566, 1097	1382, 1709, 1709	158, 1627, 1423	1913, 1668, 770
	Bare				
Failure Mechanism	D,D,D	D,D,D	D,D,D	D,D,D	D,D,D
Pressure Required	1913, 1219, 1995	158, 811, 403	852, 852, 770	1668, 1750, 1341	158, 321, 1464
¹ Failure Mechanism Reported as: A - Substrate to Powder B - Powder to Liquid Primer C - Liquid Primer to Liquid Topcoat D - Conversion Coat to Liquid Primer E - Plug to Liquid Topcoat None - No Adhesion Failure					
² - See Photos 2					

Field Reparability: Initial Adhesion

Initial Adhesion was checked with the crosshatch method in UDRI/CTIO Laboratory Procedure CCG-LP-008 Rev 03, Crosshatch; Reference ASTM D 3359-02. The coupons were cured for 14 days prior to testing and the coupons were acclimated to an environment of 72°F/50% relative humidity for 24 hours prior to testing. The initial coupons tested were divided into two groups. The first group (101-103) is the scuff-to-taper transition area and the second group (104-107) is the taper-to-bare transition area. The scale used in Figure 7.6 was used for all crosshatch adhesion ratings.





Classification - Percent Area Removed					
5B 0%		3B 5 - 15%		1B 35 - 65%	
4B < 5%		2B 15 - 35%		0B > 65%	

Figure 7.6 Crosshatch Adhesion Rating Scale

No failures were observed between the primer-to- powder interfaces. Except for one coupon from System A - scuff only, the initial adhesion ratings were all 3 or higher (See Table 7.8).

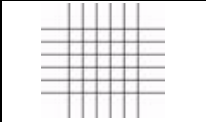
Table 7.8 Initial crosshatch adhesion results

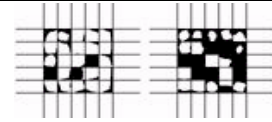
System	A	B	C	D	E
Test	Scuff to Taper (Ratings of 3 Panels)				
Initial Adhesion	3,3,1	4,4,4	3,4,3	4,4,4	4,4,4
	Taper to Bare (Ratings of 3 Panels)				
Initial Adhesion	3,3,3	4,4,3	3,3,3	3,4,4	4,4,4

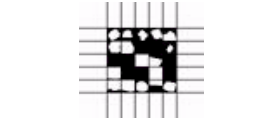
Field Reparability: DI Water Immersion

This test was performed using UDRI/CTIO Laboratory Procedure, CLG-LP-033 Rev 05, Wet Tape Adhesion. Coupons were sheared and immersed in DI water for 24 hours at room temperature. Within 30 minutes of being pulled from the beaker the coupons were dried with a clean lint-free cloth before being scribed with a “Modified X” as shown in Figure 7.7. The coupons were prepared so that the intersection of the scribe “X” was located at the transition area of the “scuff-to-sand” and “sand-to-bare.” The coupons were tested by pressing pressure sensitive tape (3M 250) over the scribed area with a 2.2 kg rubber roller. The tape was then pulled in a rapid motion perpendicular to the surface of the coupon. The coupons were evaluated per the following scale found in Table 7.99.

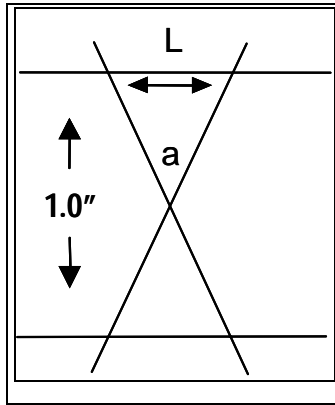

Figure 7.7 Modified X-cut within parallel cuts

Table 7.9 Wet tape adhesion rating scale

5A	No peeling or removal of coating
4A	Trace peeling or removal along incision or intersections
3A	Jagged removal along incisions up to 1/16 inch on either side
2A	Jagged removal along most incisions up to 1/8 inch
1A	Removal from most of the inscribed area
0A	Removal beyond the inscribed area

The coupons were prepared so that the intersection of the scribe “X” was located at the transition area of the “scuff-to-sand” and “sand-to-bare.” The only systems to fail the adhesion tests were systems pretreated with Prekote and exposed to DI water. The reparability of the powder topcoat with the liquid primer and liquid topcoat was not an issue; the failure mechanism was at the substrate-to-powder interface. This is similar to the results found in the PATTI Adhesion tests.

Field Reparability: Hydraulic Immersion Testing

UDRI/CTIO Laboratory Procedure CCG-LP-023, Fluid Immersion – Hydraulic Fluid, was used to perform this test. Reference MIL-PRF-85285. The coupons were immersed in the two different hydraulic fluids, MIL-H-5606 and MIL-H-83282, for 24 hours at 66°C (150°F). After exposure was complete, the coupons were removed from the beaker and examined for blistering, corrosion spots, and other film failures; results were recorded. After the evaluations were made, the coupons were cleaned with a 10% solution of MIL-C-87937 alkaline cleaner and rinsed with DI water. The coupons were then allowed to air dry for two hours followed by pencil hardness and adhesion testing within a 24-hour period. Adhesion results are summarized in Table 7.10.

Table 7.10 Post hydraulic immersion crosshatch adhesion results

System	A	B	C	D	E
Test	Scuff to Taper (Ratings of 3 Panels)				
MIL-H-5606	4,4,4	4,4,4	4,3,3	3,4,4	4,4,4
MIL-H-83282	4,2,4	4,4,4	4,4,4	4,4,4	4,4,3
	Taper to Bare (Ratings of 3 Panels)				
MIL-H-5606	4,4,4	4,4,4	3,3,4	4,4,4	4,4,4
MIL-H-83282	4,4,4	4,4,4	4,4,4	4,4,4	2,4,4

The reparability of the powder topcoat does not appear to be a concern. The adhesion failures found, other than the complete failures over Prekote, were at the interface between the liquid primers (Deft 02-Y-40 or EWDY048) and the liquid topcoat. The interface between the powder topcoat and the liquid primer did not have any adhesion problems.

The candidate powder coating performs well over a standard Alodine 1200S chromated conversion coat. Adhesion is poor over the Prekote non-chrome pretreatment. Further development is necessary if use over this pretreatment is desired. Testing over other non-chrome pretreatments such as Alodine 5200/5700 or AC Tech AC-131 (Boegel) may also be warranted.

Color

The primary color target is a military gloss white (17925; in Federal Color Standard 595B). This color is common on military support equipment and will serve as the first generation of this powder coating. Future colors that may be explored as part of a follow-on program, such as ESTCP, would include camo-green (24052) and a flat military grey (36375). The gloss white color was matched to a maximum ΔE of 2, using a Macbeth Colorimeter, at Crosslink Powder Coatings, Inc.

Conclusions

This work details the final testing and evaluation of a low temperature cure powder coating developed for military ground support equipment. Tests were performed with military partners and private industry and included cleanability, strippability, field repair, color matching, heat resistance, and UV-B weathering. Filiform and cyclic corrosion is underway at NavAir and the final results were not complete at the time of this report but are projected to be available by mid 2005. The powder coating was shown to fulfill strippability requirements and cleanability was met with more than one QPL approved cleaner. Additional refinement of the coating's flow additive system and augmentation of the crosslinker with a functional polyacrylate were shown to bring higher levels of cleanability and improvements in surface quality. Field repair evaluations performed by the AFRL showed acceptable compatibility and adhesion to the patch system. Color matching was verified at Crosslink Powder Coatings and the stability to heat treatment has been demonstrated.

Chapter 8: Advancements Toward Aircraft Applications of Low Temperature Curing, 120 °C – 30 min, Powder Coatings

Abstract

A novel GE resin has been studied in a low temperature cure powder coating to help meet stringent toughness and chemical resistance requirements demanded by military aircraft. This research builds off previous work wherein a low temperature cure powder coating solution was developed for military ground support equipment. Of most significance, simultaneous improvements in impact and MEK chemical resistance, to levels that now meet performance specifications, have been demonstrated. This was achieved with minimal compromise of other coating physical properties, but further optimization, particularly with respect to surface quality, will be necessary to arrive at a complete aircraft solution.

Introduction

Work reported in chapters 2 and 4 details the development of an exterior use corrosion protection powder coating that cures at 120 °C within 30 minutes. The powder coating was developed for use on ground support equipment to replace the current solvent borne system conforming to MIL-PRF-85285D Type II. This report focuses on technology advancements towards meeting aircraft applications using novel GE resins. Relative to ground support equipment, aircraft have additional requirements in toughness and chemical resistance. Table 8.1 summarizes the required screening performance criteria for aircraft applications.

Table 8.1 Screening specifications for aircraft applications.

Property	Test	Units	Specification	
			LSL	USL
Thickness	Gauge (eddy current, magnetic induction)	mils	2.3	3.2
Adhesion	Crosshatch ASTM D3359-97	ASTM scale	4B	-
Flexibility	Mandrel Bend ASTM D522-93	failure dia. in.	-	0.25
Toughness	GE Impact	% Elongation	40*	-
Hardness	Pencil Hardness ASTM D3363	pencil #	2H	-
Chemical Resistance	MIL-H-83282 Fluid Immersion 24 hrs.	delta pencil #	-	2
	MIL-H-5606 Fluid Immersion 24 hrs.	delta pencil #	-	2
	MEK Double Rub ASTM D5402	double rubs	25	
Weathering	Xenon Arc, 500 hrs ASTM G26-96	ΔGloss	-	10
		ΔColor	-	1
Gloss	60° Gloss ASTM D523	gloss units	90	-
Surface Quality [†]	DOI Wavescan, calibrated to PCI standards	standard #	4	-
Corrosion Resistance	Salt Fog, ASTM B117	scribe undercut rating	10	-
	SO2 500 hrs, ASTM G85	scribe undercut rating	7	-
	Cyclic on scribed steel GM 9540P	cycles to failure	80	-
	Filiform ASTM 2803-93	in.	-	0.25

*Aircraft applications require 40% elongation while ground equipment requires 5%

Experimental

Materials and Test Substrates

All commercial raw materials used in this study were used as received from their manufacturers. In formulation studies two acid functional GE resins, referred to as GE A and B, both with an equivalent molecular weight of 1230, were blended with a high flow, acid functional polyester resin having an equivalent molecular weight of 1650. Table 8.2 provides details on the specific formulations studied. All resin systems were combined 93:7 with triglycidylisocyanurate (TGIC). A silica bound flow additive was used to enhance surface quality by improving flow and leveling. As part of this work, two additional flow additives were investigated: a commercial master batched flow additive and a glycidal methacrylate flow additive. The master batched is premixed at 5-wt % in an acid functional polyester. Benzoin was used as a degassing agent (Solutia). A hindered amine light stabilizer (HALS) was used to provide stability to UV exposure. A corrosion inhibitor was added to improve corrosion resistance. The coating color was matched to a military white federal number 17925.

Table 8.2 Powder coating components including GE resin. Formulation is approximately 71% resin for all blends.

Function	Chemical Component	Content* (wt %)
Crosslinker	TGIC	5.3
Resins	Polyester Resin	71 (Total blend)
	GE Resin A	
	GE Resin B	
Curing Catalyst	Benzyltrimethylammonium Bromide	0.5
Flow Promoters	Si Bound	1.5
	Commercial Masterbatch	20
	Acrylate Flow Additive	6
Additives & Pigments	--	22.0

Melt Compounding and Powder Grinding

Raw materials were either dry-blended in a 1-liter Henschel mechanical mixer (60 seconds at 2500 rpm) or in a small coffee grinder (two 30-second cycles with a 30 second bag shake between cycles). Melt mixing employed the use of a 16 mm twin-screw extruder (lab model Prism) at 250 rpm with a max barrel temperature of 100 °C. For cooling, the extrudate was passed through a water-cooled chill roll (lab model BBA). The extrusion product was then ground on a Retsch hammer mill (model ZM-100) using a 200- μ m ring sieve. Lastly, the powder was passed through 140-mesh screen mounted to a Vort-Siv vibratory sieve (lab model RBF-10).

Test Substrates

Chromated 2024T3 aluminum was the primary substrate used in this research. Adhesion, hardness, chemical resistance, weathering, surface quality, and corrosion testing were all performed on coatings applied to this substrate. A thinner (.020 in.) version of 2024 without T3 heat treatment was used for GE impact tests, while a slightly thicker .032

version, anodized according to MIL-A-8625 Type I was used for conical flexibility. All test substrates were obtained from Q-panel Lab Products.

Coating Preparation

Prior to coating, test substrates were cleaned with a MEK wipe. All powders were applied in an ETI Flexicoat[®] manual powder coating booth using a Nordson SureCoat[®] cup gun with an applied voltage of 70 kV, application pressure of 30 psi, and rinse rate setting of 20 psi. Curing was performed in a Blue-M convection oven at 120 °C for 30 minutes. For each panel, mean coating thickness and standard deviation was evaluated based on 6 measurements using an ElektroPhysik Minitest 4100. All tested coatings targeted a thickness specification between 2.3-3.2 mils. After curing, panels were held at ambient conditions for a minimum of 24 hours before testing.

Property Evaluation

Adhesion testing was performed using a Gardner crosshatch knife and Permacel[®] tape according to ASTM D3359. Flexibility testing followed ASTM D522 and was performed with a Gardner mandrel bend tester. Direct impact strength was tested in accordance with ASTM D5420 using a Gardner impact tester. GE impact strength is reported as percent elongation and performed following CTIO lab procedure CCG-LP-016 REV 06. Pencil hardness was assessed following ASTM D3363. Solvent resistance was determined using the MEK double rub test, ASTM D5402, with failure reported at substrate read-through.

For accelerated weathering an Atlas Ci35a Xenon Weather-Ometer[®] was used. To assess performance, color coordinates were measured as a function of exposure using a Macbeth Colorimeter (Color-Eye 7000A) following ASTM D2244. The ΔE color change is reported after 500 hrs of exposure.

Gloss was measured at 20° and 60° using a BYK Gardner Tri-Gloss Meter. 20° gloss was measured when the 60° gloss was 70% or greater. Coating surface quality was determined using a BYK Gardner Wavescan[™] Distinctness of Image (DOI) instrument with the Wd output calibrated relative to Powder Coating Institute (PCI) surface quality standards ($PCI=(Wd-84)/-7.29$). Results are reported in PCI units ranging from 1-10, with 10 corresponding to the best quality. In samples where gloss was inadequate to allow use of the Wavescan, visual assessments were made in side-by-side comparison with the surface quality standards.

Hydraulic Immersion Testing

Testing was performed according to MIL-PRF-85285D. All test fluids used in this study were used as received. Cured panels were immersed in a petridish containing one of two grades of hydraulic fluid, MIL-H-5606 or MIL-H-83282, and then placed in a 66° +/- 3°C equilibrated oven for twenty-four hours. After cleaning with a 10% solution of alkaline cleaner followed by a DI water rinse, the test specimens were evaluated for blistering, pencil hardness and adhesion. Changes in hardness and adhesion were determined relative to untested panels. Chromated aluminum, 2024T3, was the primary substrate for this research. All aluminum test substrates were obtained from Q-Panel Lab Products.

Results and Discussion

Blend Plan I

GE resin was blended at 75%, 50%, and 25% by weight with the Crylcoat 630 polyester resin. Two additional formulations, one with 100% polyester and the other with 100% GE resin, were also studied. Figure 8.1 outlines this blend plan schematically and these coatings were all formulated according to the recipe provided in Table 8.2. With the exception of a reduction in catalyst loading from 0.6% to 0.5% this formulation is the same as that previously developed for ground support equipment. Work reported in chapter 4 details work showing lower catalysis requirements for formulations containing GE resin.

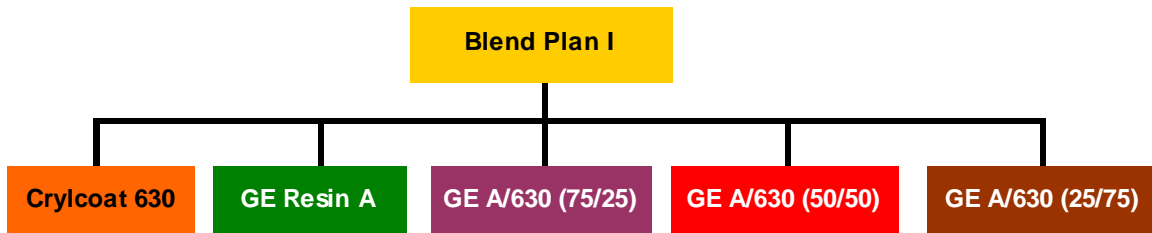

Figure 8.1 Blend plan I for GE Resin A.

A summary of the physical properties for Blend Plan I is shown in Table 8.3. With respect to the specifications given in Table 8.1, passing performance is noted by green fill and failure is color-coded red. Formulations containing 50% or greater GE resin exhibited improved toughness relative to the 100% polyester system; toughness was increased to the test maximum of 60% exceeding the 40% requirement for aircraft. Formulations with 75% or more GE resin demonstrated improved MEK performance passing 200 double rubs, and cleanability rose to 95%. Trade-offs were seen with these new blends, however, and formulations containing more than 50% GE resin showed deficiencies in gloss, surface quality, and color stability during weathering. Incorporating GE resin at 50% caused only a 3% reduction in gloss, but a 25% reduction in gloss was experienced with 100% GE Resin A. Similarly, a PCI value of 3 was realized for the systems containing 50% and 25% of the GE resin, but the value dropped to 2 with 75% and 100% resin. All formulations containing GE resin exhibited poor color stability as a function of Xenon-Arc exposure. This is expected and it is understood that color compensation will be necessary with this resin to correct for the ultraviolet light absorbing chemistry.

Table 8.3 Blend plan I physical properties.

Property	Test	Crycoat 630	100% GE A	GE A/630 (75/25)	GE A/630 (50/50)	GE A/630 (25/75)	
Adhesion	Crosshatch	5B	5B	5B	5B	5B	
Flexibility	Mandrel Bend	3/8"	Pass	Pass	Pass	5/16"	
Toughness	G.E. Impact--Aircraft	2%	≥60%	≥60%	≥60%	20%	
Hardness	Pencil	2H	2H	3H	3H	H	
Chem Resist.	MEK DR	93	200	200	112	102	
	Hydrc. Fld. Mil-H-5606	2H	2H	2H	2H	2H	
	Hydrc. Fld. Mil-H-83282	2H	2H	2H	2H	2H	
Weathering	Xenon-arc (250 hrs)	ΔGloss	1.5	1.7	3.2	1.0	0.9
		ΔColor	0.1	3.5	3.3	2.7	2.0
Cleanability	75% Minimum	34	95	94	69	59	
Gloss	60° Gloss	90	67	83	87	92	
	20° Gloss	63	21	36	40	54	
Surface Quality	DOI (PCI Number)	4	2 (visual)	2 (visual)	3	3	

Blend Plan II

Based on the performance of the formulations tested in Table 8.3 a new blend plan was initiated that explores the region between 50% and 25% GE resin; results from Blend Plan I suggest that an optimum may exist within this region. Due to the small scale manufacturing of the experimental GE resin a new batch was required for this experiment. It is similar to, but not an exact replicate of GE Resin A; it is referenced here as GE Resin B. In this experiment the 50% and 25% formulations were repeated. Three additional formulations based on 35% GE resin (without UVA, with UVA, and with increased catalyst) were also studied as shown in Figure 8.2.

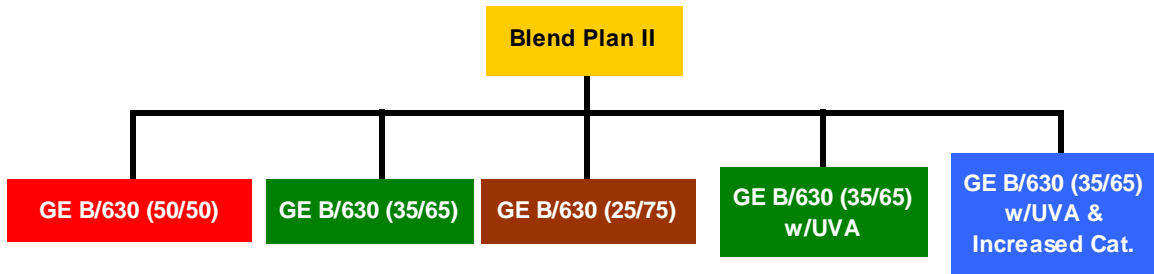

Figure 8.2 Blend plan II for GE Resin B.

The physical properties for Blend Plan II formulations are summarized in Table 8.4. It should be noted that hydraulic immersion testing was not performed as with the preceding study because a strong passing performance was demonstrated with this chemistry. Relative to Blend Plan I, formulations repeated with 25% and 50% GE Resin B show an increase in surface quality (from 3 to 4) and an improvement in MEK resistance (to the test maximum of 200). These differences may be in part attributed to batch-to-batch variation between GE Resin A and B owing to the small scale manufacturing process. For instance, such differences may arise from modifications to the isolation procedure. Consistent with results from Blend Plan I, a minimum of 50% GE resin is required to meet the aircraft toughness specification. The 35% GE resin formulation had a toughness of 20% failing specification requirements. The addition of UVA to the 35% GE resin formulation further reduced toughness to 5%, and caused deficiencies in both flexibility and hardness. Increasing catalyst from 0.5% to 0.6% in the UVA system improved flexibility and hardness to meet specification requirements. Overall, the formulation modifications with catalyst and/or UVA did not improve

performance. The formulation with 50% GE Resin B (without UVA or increased catalyst) offers the best balanced performance nearly fulfilling all screening requirements except cleanability and color retention in weathering.

Table 8.4 Blend Plan II physical properties.

Property	Test	GE B/630 (50/50)	GE B/630 (35/65)	GE B/630 (25/75)	GE B/630 (35/65) w/UVA	GE B/630 (35/65) w/UVA & Increased Cat.	
		0.5 BTMABr	0.5 BTMABr	0.5 BTMABr	0.5 BTMABr	0.6 BTMABr	
Adhesion	Crosshatch	5B	5B	5B	5B	5B	
Flexibility	Mandrel Bend	Pass	Pass	Pass	P-1/2	Pass	
Toughness	G.E. Impact--Aircraft	≥60%	20%	1%	5%	5%	
Hardness	Pencil	2H	2H	3H	H	2H	
Chem Resist.	MEK DR	200	200	200	200	200	
Weathering	Xenon-arc (500 hrs)	ΔGloss	8.2	6.5	-----	-----	8.2
		ΔColor	3.3	2.8	-----	-----	3.4
Cleanability	75% Minimum	64.5	57.3	-----	-----	55.8	
Gloss	60° Gloss	92	92	93	93	94	
	20° Gloss	49	54	59	58	52	
Surface Quality	DOI (PCI Number)	4	3	4	4	3	

Blend Plan III

This last set of formulations builds on the results of Blend Plan II and investigates several flow additives that have potential to bring improvements in surface quality, gloss, and cleanability. The same batch of GE Resin B utilized in Blend Plan II is also used for this experiment. As shown in Figure 8.3, two levels of silica bound flow additive, a master batched flow additive, and a GMA acrylate are incorporated into a 50% GE resin system for a total of four formulations. The formulation containing 50% GE resin with 1.5% silica bound flow additive is a replicate from Blend Plan II. One additional formulation with the silica bound flow additive at 1.5% is blended into a 60% GE resin system.

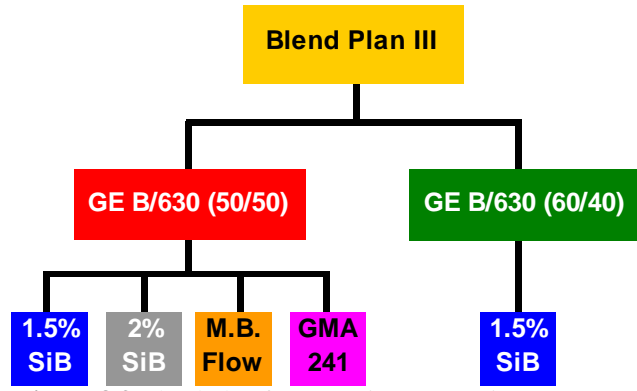

Figure 8.3 Blend plan for screening GE Resin.

The physical properties for Blend Plan III are summarized in Table 8.5. The 50% GE resin formulation replicated from Blend Plan II had comparable mechanical performance with a slight reduction in surface quality and gloss that may be, in part, due to unintended variations in laboratory scale melt processing and application. The three formulations containing alternative flow additives (2.0% silica bound, master batched, acrylate) all showed an improvement in surface quality of 1 PCI unit relative to the conventional flow additive (1.5 % silica bound). This, however, was at the expense of toughness and

cleanability. In formulations containing alternative flow additives a minimum 50% reduction in toughness and 7% drop in cleanability was experienced. The 60% GE resin formulation showed improved MEK performance relative to the 50% formulation while maintaining requisite physical properties and without significantly compromising surface quality. This represents a real improvement as conventionally tradeoffs are normally suffered, particularly between chemical resistance and toughness.

No formulation changes investigated here offered improvements in cleanability performance. However, as reported in the cleanability section in chapter 7 several cleaners have been identified that enable >75% cleanability of similar powder coating chemistries. Overall, formulation containing alternative flow additives did not offer improvements to the cumulative system performance seen in the 50% and 60% GE Resin formulations both with the 1.5% silica bound flow additive. Weathering is not included in the evaluation of Blend Plan III as no changes in performance are anticipated relative to Blend Plans I and II.

Table 8.5 Blend Plan III physical properties.

Property	Test	GE B/630 (50/50)	GE B/630 (50/50)	GE B/630 (50/50)	GE B/630 (50/50)	GE B/630 (60/40)
		1.5 % Flow	2.0 % Flow	M.B. Flow	GMA-262	1.5 % Flow
Adhesion	Crosshatch	5B	5B	5B	5B	5B
Flexibility	Mandrel Bend	Pass	Pass	Pass	5/8	Pass
Toughness	G.E. Impact--Aircraft	60%	30%	33%	2%	60%
Hardness	Pencil	2H	2H	2H	3H	2H
Chem Resist.	MEK DR	144	164	167	>200	>200
Cleanability	75% Minimum	63	56	54	54	54
Gloss	60° Gloss	89	87	93	89	90
	20° Gloss	43	44	50	47	41
Surface Quality	Wd	3	4	4	4	3

Conclusions

This work introduces a novel GE resin that, as part of a complete powder coating system, helps meet the aircraft requirement for toughness defined in MIL-PRF-85285 while maintaining adequate chemical performance. This is a significant achievement as a tradeoff is normally experienced between these attributes, particularly in low temperature cure powder coatings. Building towards this progress, three blend series that incorporate the GE resin at different weight ratios and with multiple flow additives were completed. Formulations have been developed that narrow the deficiency with respect to screening requirements for aircraft applications. Further optimization of the formulation and GE resin would be required to close the gap. Future work can build off this foundation of research.

Conclusions

GE Global Research along with partners at Crosslink Powder Coatings Inc., the Department of Defense, and the Department of Energy have successfully completed a Strategic Environmental Research and Development Program (SERDP) funded research project to develop an exterior-use, corrosion-protection powder coating that cures at a temperature of 120 °C within 30 minutes. This technology has been tailored for military ground support equipment constructed from temperature sensitive, chromated, T3 annealed, 2024 grade aluminum. The coating has been shown to simultaneously meet all screening performance criteria including impact toughness, hardness, salt-fog and SO₂ corrosion resistance, surface quality, and exterior durability; longer term cyclic and filiform corrosion tests are underway and should be available by mid 2005. As part of this effort, the coating was produced at manufacturing scale at Crosslink Powder Coatings Inc. and subjected to more exhaustive qualification testing with partners at Air Force Research Laboratory, NavAir, and Honeywell DoE. These powder coatings are inherently free from volatile organic compounds, chromates, and hazardous air pollutants. Relative to the incumbent solvent-borne urethane paint system, the powder coating eliminates the need for a chromated primer and has the potential to increase application efficiencies by 35% while reducing raw material and paint facility operating costs. Crosslink Powder Coatings Inc., the manufacturing partner for the coating product, has developed a viable production method that can support future needs for this powder technology. To translate this technology to the next stage of demonstration and validation, partners from the Air Force Research Laboratory and Material Command at Wright Patterson Air Force Base are planning to lead the submission of an Environmental Securities Technology Certification Program (ESTCP) project proposal.

Appendix

Technical Publications

Peer Reviewed Journals

1. Merfeld, Glen; Mordhorst, Steve; Koeniger, Rainer; Acar, Ersin; Molaison, Chris; Suriano, Joe; Irwin, Pat; Warner, Ron Singh; Gray, Ken; Smith, Mark; Kovaleski, Kevin; Garrett, Greg; Finley, Steve; Meredith, Deborah; Spicer, Mike; Naguy, Tom. *Development of Low Temperature Curing (120° C) Corrosion Protection Powder Coatings for Thermally Sensitive Substrates*; Accepted to Journal of Coatings Technology. 2004.
2. Merfeld, Glen; Molaison, Chris; Koeniger, Rainer; Acar, Ersin; Mordhorst, Steve; Suriano, Joe; Irwin, Pat; Warner, Ron Singh; Gray, Ken; Smith, Mark; Kovaleski, Kevin; Garrett, Greg; Finley, Steve; Meredith, Deborah; Spicer, Mike; Naguy, Tom. *Acid/Epoxy Reaction Catalyst Screening for Low Temperature (120 °C) Powder Coatings*; Accepted to Progress in Organic Coatings. 2004.

Conference Symposium Proceedings

1. Merfeld, Glen; Mordhorst, Steve; Molaison, Chris; Acar, Ersin; Koeniger, Rainer; Suriano, Joe; Irwin, Pat; Warner, Ron Singh; Gray, Ken; Smith, Mark; Kovaleski, Kevin; Garrett, Greg. *Low Temperature Cure (120 °C) Durable, Corrosion Protection Powder Coatings for Temperature Sensitive Substrates*; 14th Annual Alternatives to Toxic Materials Symposium, Scottsdale, AZ, Dec. 8-11, **2003**.
2. Merfeld, Glen; Mordhorst, Steve; Koeniger, Rainer; Acar, Ersin; Molaison, Chris; Suriano, Joe; Irwin, Pat; Warner, Ron Singh; Gray, Ken; Smith, Mark; Kovaleski, Kevin; Garrett, Greg; Finley, Steve; Meredith, Deborah; Spicer, Mike; Naguy, Tom. *Development of a Low Temperature Curing (120 °C) Corrosion Protection Powder Coatings for Thermally Sensitive Substrates*; Proceedings of the International Waterborne, High solids and Powder Coatings Symposium, New Orleans, LA, Feb. 18-20, **2004**.
3. Merfeld, Glen; Molaison, Chris; Koeniger, Rainer; Acar, Ersin; Mordhorst, Steve; Suriano, Joe; Irwin, Pat; Warner, Ron Singh; Gray, Ken; Smith, Mark; Kovaleski, Kevin; Garrett, Greg; Finley, Steve; Meredith, Deborah; Spicer, Mike; Naguy, Tom. *Acid/Epoxy Reaction Catalyst Screening for Low Temperature (120 °C) Powder Coatings*; Proceedings of the International Waterborne, High solids and Powder Coatings Symposium, New Orleans, LA, Feb. 18-20, **2004**.
4. Merfeld, Glen. *Low Temperature Cure (120 °C) Exterior Use, Corrosion Protection Powder Coatings*; Annual Partners in Environmental Technology Technical Symposium, Nov. 29 – Dec. 2, **2004**, pp 21.

Published Technical Abstracts

1. Molaison, Chris; Merfeld, Glen; Acar, Ersin; Koeniger, Rainer; Mordhorst, Steve; Suriano, Joe. *Acid/Epoxy Catalyst Screening for Low Temperature Cure (120 °C) Powder Coatings*; Annual Partners in Environmental Technology Technical Symposium and Workshop, Dec. 2-5, **2003**, pp 237.
2. Mordhorst, Steve; Merfeld, Glen; Molaison, Chris; Acar, Ersin; Koeniger, Rainer; Suriano, Joe; Warner, Ron Singh; Gray, Ken; Smith, Mark; Kovaleski, Kevin; Garrett, Greg. *Low Temperature Cure (120 °C) Durable, Corrosion Protection Powder Coatings for Temperature Sensitive Substrates*; Annual Partners in Environmental Technology Technical Symposium and Workshop, Dec. 2-5, **2003**, pp 238.
3. Mordhorst, Steve; Merfeld, Glen; Koeniger, Rainer; Suriano, Joe; Warner, Ron Singh; Gray, Ken; Smith, Mark; Kovaleski, Kevin; Garrett, Greg; Finley, Steve; Meredith, Deborah; Mongelli, Jerry; Fontenot, Shawn; Joseph, Chris; Naguy, Tom; Parker, Grant; Spicer, Mike. *Low Temperature Cure (120 °C) Durable, Corrosion Protection Powder Coatings for Temperature Sensitive Substrates*; Annual Partners in Environmental Technology Technical Symposium and Workshop, Nov 29 – Dec. 2, **2004**, pp 155.

Other Technical Material

1. 1 Patent on GE Catalyst
2. 2 Patents on GE Resin