

Investigation of a Forward Looking Conformal Broadband Antenna for Airborne Wide Area Surveillance

Hany E. Yacoub
Department Of Electrical Engineering & Computer Science
121 Link Hall, Syracuse University,
Syracuse, NY 13244-1240
E-mail: hyacoub@syr.edu

Abstract: The presented work describes an antenna with 2:1 bandwidth (400-800 MHz) that will be used in airborne wide area surveillance. Several designs of the Log-Periodic configuration are introduced in addition to a TEM Horn. Performance parameters like bandwidth, beamwidth, gain and input impedance are discussed for all the designs.

Keywords: Broadband, Antenna, Log-Periodic, TEM Horn

1. Introduction:

The need for conformal antennas is ever growing due to its functionality and low cost of production. But the associated bandwidth limitation presents a hurdle for antenna designers. More and more broadband conformal designs are currently evolving, but certainly have not reached their maturity. The presented work is one step on that way where classic designs like the Log-Periodic and TEM Horn configurations are adapted to a conformal structure. The antenna is intended to be a part of an array that would occupy top and bottom sides of the wing of an aircraft for wide area surveillance. The structure is modeled as a section of the wing that would include the antenna with a PEC in the bottom to simplify calculations. The wing is 5 ft long and 1 ft high with $\epsilon_r = 2$. The curved part of the wing is modeled as a circular revolution of planes that are less than $\lambda/10$ in width as shown in figure 1.

The antenna will be on the top surface in addition to elements that would be positioned on the curved surface. The desired gain is intended to be of 4 dB within an elevation θ from 0° to 20° measured from the X-Y plane. All simulations were performed using WIPL-D Software [1].

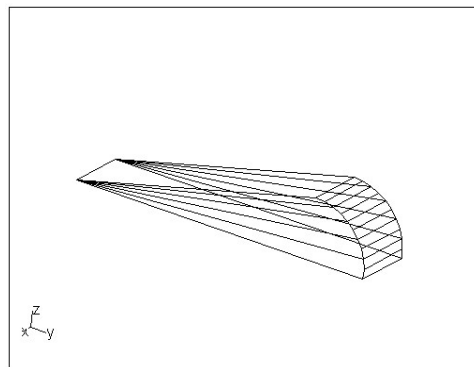

Figure 1. Section of the wing structure

Report Documentation Page

Form Approved
OMB No. 0704-0188

Public reporting burden for the collection of information is estimated to average 1 hour per response, including the time for reviewing instructions, searching existing data sources, gathering and maintaining the data needed, and completing and reviewing the collection of information. Send comments regarding this burden estimate or any other aspect of this collection of information, including suggestions for reducing this burden, to Washington Headquarters Services, Directorate for Information Operations and Reports, 1215 Jefferson Davis Highway, Suite 1204, Arlington VA 22202-4302. Respondents should be aware that notwithstanding any other provision of law, no person shall be subject to a penalty for failing to comply with a collection of information if it does not display a currently valid OMB control number.

1. REPORT DATE 23 APR 2004	2. REPORT TYPE N/A	3. DATES COVERED -	
4. TITLE AND SUBTITLE Investigation of a Forward Looking Conformal Broadband Antenna for Airborne Wide Area Surveillance		5a. CONTRACT NUMBER	
		5b. GRANT NUMBER	
		5c. PROGRAM ELEMENT NUMBER	
6. AUTHOR(S)		5d. PROJECT NUMBER	
		5e. TASK NUMBER	
		5f. WORK UNIT NUMBER	
7. PERFORMING ORGANIZATION NAME(S) AND ADDRESS(ES) Department Of Electrical Engineering & Computer Science 121 Link Hall, Syracuse University, Syracuse, NY 13244-1240		8. PERFORMING ORGANIZATION REPORT NUMBER	
9. SPONSORING/MONITORING AGENCY NAME(S) AND ADDRESS(ES)		10. SPONSOR/MONITOR'S ACRONYM(S)	
		11. SPONSOR/MONITOR'S REPORT NUMBER(S)	
12. DISTRIBUTION/AVAILABILITY STATEMENT Approved for public release, distribution unlimited			
13. SUPPLEMENTARY NOTES See also ADM001763, Annual Review of Progress in Applied Computational Electromagnetics (20th) Held in Syracuse, NY on 19-23 April 2004., The original document contains color images.			
14. ABSTRACT			
15. SUBJECT TERMS			
16. SECURITY CLASSIFICATION OF:			17. LIMITATION OF ABSTRACT
a. REPORT unclassified	b. ABSTRACT unclassified	c. THIS PAGE unclassified	UU
			18. NUMBER OF PAGES 5
			19a. NAME OF RESPONSIBLE PERSON

2. Log-Periodic Configuration

The configuration of the Log-Periodic antenna is governed by the ratio between the lengths of its elements and the distance separating them. Figure 2 [2] shows the different parameters of the antenna. The equations governing the design are as follows [2]:

$$\frac{l_{n+1}}{l_n} = \frac{S_{n+1}}{S_n} = k \tag{1}$$

$$\frac{l_{n+1}}{l_1} = k^n = F \tag{2}$$

where k is a constant, $n+1$ is the number of elements and F is the frequency ratio or bandwidth. Figure 3 [2] shows the optimum design values for the Log-Periodic configuration.

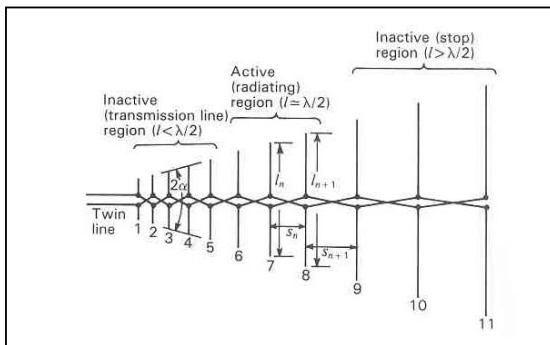

Figure 2. Parameters of the Log-Periodic Antenna

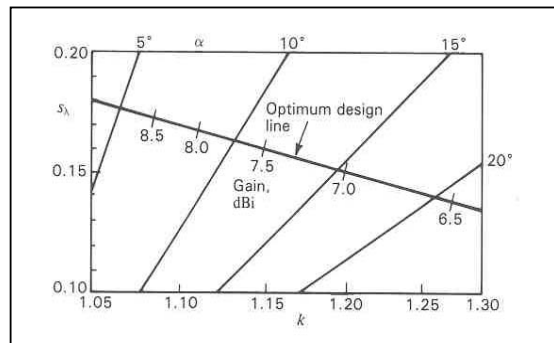

Figure 3. Optimum design lines

Parameters were chosen for the highest gain given the availability of space for larger number of elements. S was 0.178, k was 1.054 and n was 17 (18 elements). Elements and feeding wires were 8 mm in diameter. Feeding network was designed as crossing twin wires where the generator was placed at the smallest element to achieve a forward beam. To accommodate practical implementation, the feeding lines were placed in 2 parallel planes with a separation of 10 mm. Figures 4, 5, 6 and 7 show the antenna structure and its performance along the frequency band.

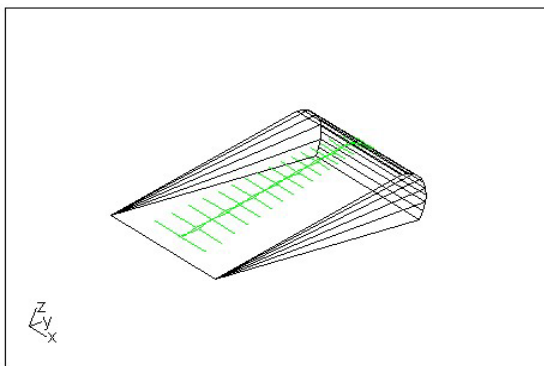

Figure 4. Log-Periodic Structure

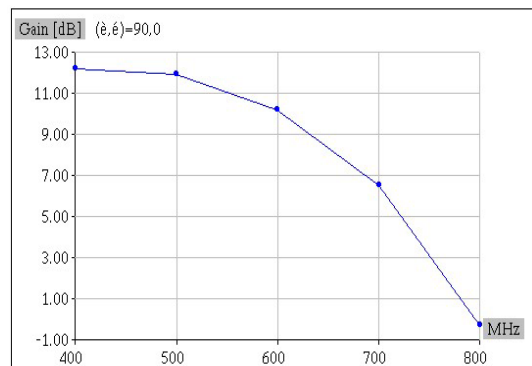

Figure 5. Gain at 0° elevation

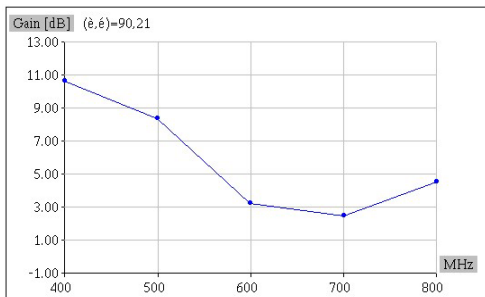

Figure 6. Gain at 21° elevation

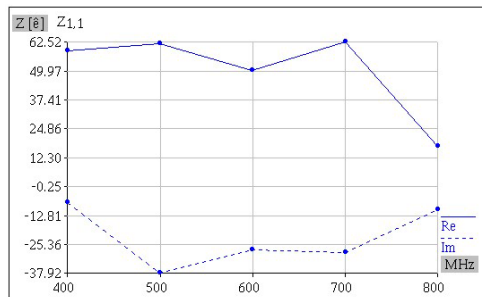

Figure 7. Input impedance

With some limited optimization S was reduced to 0.16. This design produces satisfactory results although gain is less by 1 dB than desired at higher elevations. At lower elevations on the upper edge of the frequency band gain degraded to less than 1 dB. Input impedance is relatively flat within 10Ω across most of the frequency band. The half power beamwidth is about 40° to 50° throughout the band.

3. Shifted Log-Periodic Configuration

Antenna elements were shifted where five elements would be positioned on the curved surface of the wing and the performance of the antenna was inspected. The antenna was redesigned with the same parameters ($S = 0.178$, $k = 1.054$ and 18 elements). Distances between the elements on the curved surface were measured in straight lines that are very close to the surface. Figures 8, 9, 10 and 11 show the performance of this antenna across the frequency band.

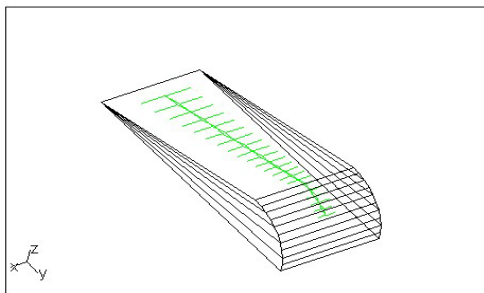

Figure 8. Shifted Log-Periodic Antenna

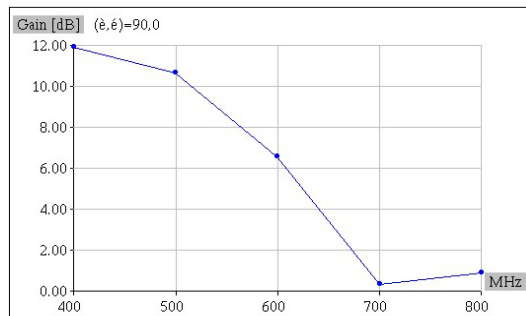

Figure 9. Gain at 0° elevation

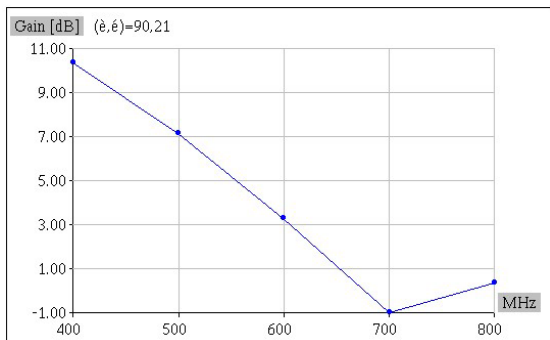

Figure 10. Gain at 21° elevation

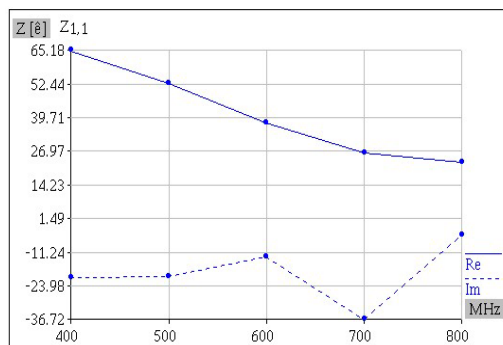

Figure 11. Input Impedance

Half power beamwidth is about 40° , which is almost the same as the previous structure. Input impedance seems to be worse in terms of flatness.

The presented results show that this shifted configuration has no performance advantage over the first one. In addition to that, designing and implementing the elements on the curved structure is more complex which makes this configuration unattractive.

4. TEM Horn Configuration

It was interesting to compare the performance of a TEM Horn configuration to the two earlier Log-Periodic configurations, especially with the elements replaced by a metallic sheet having the same size. Figure 12 shows this configuration where the antenna is fed at the midpoint of the smaller side of the metallic plate. Figures 13, 14 and 15 show the performance of the antenna across the frequency band.

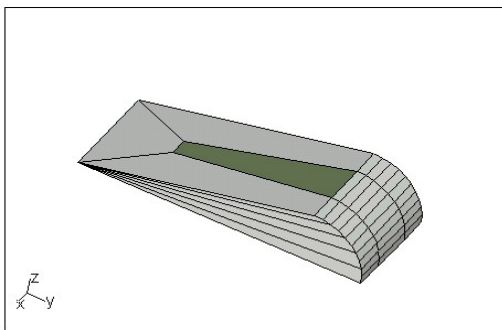

Figure 12. TEM Horn Antenna

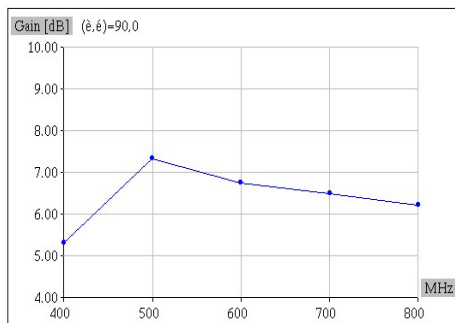

Figure 13. Gain at 0° elevation

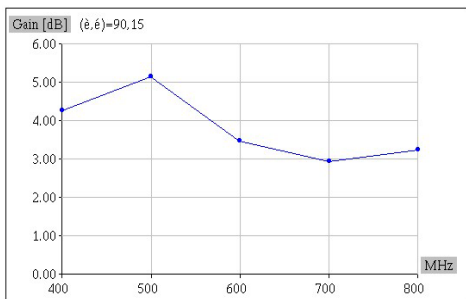

Figure 14. Gain at 15° elevation

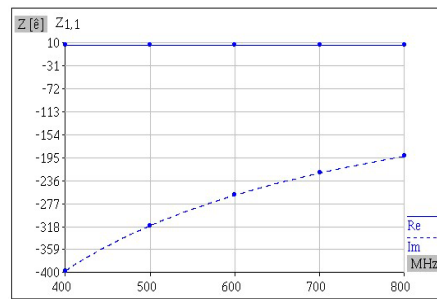

Figure 15. Input Impedance

An acceptable gain is obtained across the band, but starts degrading at elevations larger than 15° especially at higher frequencies. HPBW (Half Power Beam Width) is in the vicinity of 40° . One disadvantage can be noticed in the input impedance where the structure is highly capacitive with a large variation range (Imaginary part between $-j400 \Omega$ to $-j200 \Omega$) while the real part is almost negligible. More work need to be done to improve the input impedance of this configuration.

It is clear that the gain produced by the Log-Periodic configuration is higher than that of the TEM Horn configuration by about 5 dB in most of the frequency band (up to 700 MHz). Impedance also is flatter easing the matching task. On the other hand the flatter gain of the TEM Horn configuration is quite an advantage for signal processing.

5. Conclusion

Two Log-periodic and TEM Horn configurations were studied for a 2:1 bandwidth (400 MHz-800 MHz) conformal implementation on an aircraft wing structure. The classic Log-Periodic structure outperformed the shifted version in terms of gain at higher frequencies and in terms flatness of input impedance. In general, Log-Periodic configurations produced considerably higher gain (about 5 dB higher) and more tractable input impedance in most of the frequency band. On the other hand, TEM Horn configuration with the same size produced a considerably flatter gain than the Log-Periodic configurations.

References

- [1] WIPL-D Software (Electromagnetic Modeling of Composite Metallic & Dielectric Structures), Professional Edition 4.10
- [2] J. D. Krauss, "Antennas", Second Edition, McGraw Hill, Inc., S. 704-708, 1988