

LMT

Critical Design Review

Rings Panels 1-4

Structural Analysis

Prepared by:
ATA Engineering, Inc.
Kurt Knutson
Brian Mooney

Report Documentation Page

Form Approved
OMB No. 0704-0188

Public reporting burden for the collection of information is estimated to average 1 hour per response, including the time for reviewing instructions, searching existing data sources, gathering and maintaining the data needed, and completing and reviewing the collection of information. Send comments regarding this burden estimate or any other aspect of this collection of information, including suggestions for reducing this burden, to Washington Headquarters Services, Directorate for Information Operations and Reports, 1215 Jefferson Davis Highway, Suite 1204, Arlington VA 22202-4302. Respondents should be aware that notwithstanding any other provision of law, no person shall be subject to a penalty for failing to comply with a collection of information if it does not display a currently valid OMB control number.

1. REPORT DATE 11 DEC 2003		2. REPORT TYPE N/A		3. DATES COVERED -	
4. TITLE AND SUBTITLE LMT - Critical Design Review Ring Panels 1 - 4 Structural Analysis				5a. CONTRACT NUMBER	
				5b. GRANT NUMBER	
				5c. PROGRAM ELEMENT NUMBER	
6. AUTHOR(S)				5d. PROJECT NUMBER	
				5e. TASK NUMBER	
				5f. WORK UNIT NUMBER	
7. PERFORMING ORGANIZATION NAME(S) AND ADDRESS(ES) ATA Engineering, Inc.				8. PERFORMING ORGANIZATION REPORT NUMBER	
9. SPONSORING/MONITORING AGENCY NAME(S) AND ADDRESS(ES)				10. SPONSOR/MONITOR'S ACRONYM(S)	
				11. SPONSOR/MONITOR'S REPORT NUMBER(S)	
12. DISTRIBUTION/AVAILABILITY STATEMENT Approved for public release, distribution unlimited					
13. SUPPLEMENTARY NOTES See also ADM001773, Large Millimeter Telescope Project. , The original document contains color images.					
14. ABSTRACT					
15. SUBJECT TERMS					
16. SECURITY CLASSIFICATION OF:			17. LIMITATION OF ABSTRACT UU	18. NUMBER OF PAGES 24	19a. NAME OF RESPONSIBLE PERSON
a. REPORT unclassified	b. ABSTRACT unclassified	c. THIS PAGE unclassified			

Structural Analysis

- ◆ **Surface Distortion Analysis**
 - » **Distortion Analysis Objectives / Methods / Requirements**
 - » **Load Cases and Configurations**
 - » **Coordinate System Transformations**
 - » **Distortion Results Rings 1-4**

Rings 1-4

Distortion Analysis and Results

Distortion Analysis

- ◆ **Distortion Analysis Objectives / Methods / Requirements**
- ◆ **Load Cases and Configurations**
- ◆ **Coordinate System Transformations**
- ◆ **Distortion Results for Rings 1-4**

Distortion Analysis Objectives

- ◆ **Incorporate finalized Rings 1-4 designs into distortion evaluations**
 - » Use of latest axial rod interface point locations for boundary conditions on Ring 3
 - » Invar adjuster rods were shortened for Rings 3 & 4

- ◆ **Evaluation of Rings 1-4 with subframes**
 - » Examine Raw data RMS
 - » Perform a Best Fit Constrained as Specified
 - › Fix Local (system 11) Translation X, Y and Rotation Z
 - › COI method assumes surface acts as rigid body under the constraints

Distortion Analysis Methods

- ◆ **Finite element models with and without the subframes for Rings 1-4 were defined and run in Nastran.**
- ◆ **For the various load cases considered, displacements were recovered at each node on the surface.**
- ◆ **COI “Best Fit” code summary**
 - » **Import the NASTRAN displacements**
 - » **Calculate a half RF path length RMS relative to the ideal surface using these displacements (Raw Data RMS).**
 - » **Calculate an optimized fit surface assuming rigid body motion under specified constraints X, Y Translation and Z rotation constrained in the local coordinate system (coordinate system 11).**
 - » **Compute the RMS of half RF path length change under these constraints (Best Fit RMS Constrained as Specified) for the optimization.**

Distortion Analysis Requirements

- ◆ **Specification Requirements – Rings 3 & 5**
 - » Gravity, <15 microns
 - » Wind, <5 microns
 - » Temperature, <20 microns

- ◆ **Specification Requirements – Rings 1, 2, & 4**
 - » Gravity, <**TBR** microns
 - » Wind, <**TBR** microns
 - » Temperature, <**TBR** microns

Distortion Load Cases

- ◆ **Ring 3 No Subframe**
 - » Wind Pressure, 0.00558 psi, BC2 & BC3
 - » Temperature Soak (+20C)
 - » Temperature Gradient (+5C)
 - » Temperature Soak (+20C) & Gradient (+5C)
 - » All Gravity Cases

- ◆ **Rings 1, 2, 4 No Subframe**
 - » BC2 X, Y, Z 1g Local Gravity Load Cases

- ◆ **Rings 1-4 With Subframes**
 - » All Gravity Load Cases

Gravity Load Cases Rings 1-4

Gravity Loading Conditions for Deformation Analysis

- ◆ 1G Gravity in X, Y, Z Directions (Local Axes, Coordinate system 11)
- ◆ Gravity Effects due to Change from Adjustment Configuration to Operating Configuration
 - » Panel at 12 O'clock with BC2
Vertical telescope axis (E=90)
(-1G Z global + 1G Z local)
Horizontal telescope axis (E=0)
(1G X global + 1G Z local)
 - » Panel at 3 O'clock with BC3
Vertical telescope axis (E=90)
(-1G Z global + 1G Z local)
Horizontal telescope axis (E=0)
(1G Y global + 1G Z local)

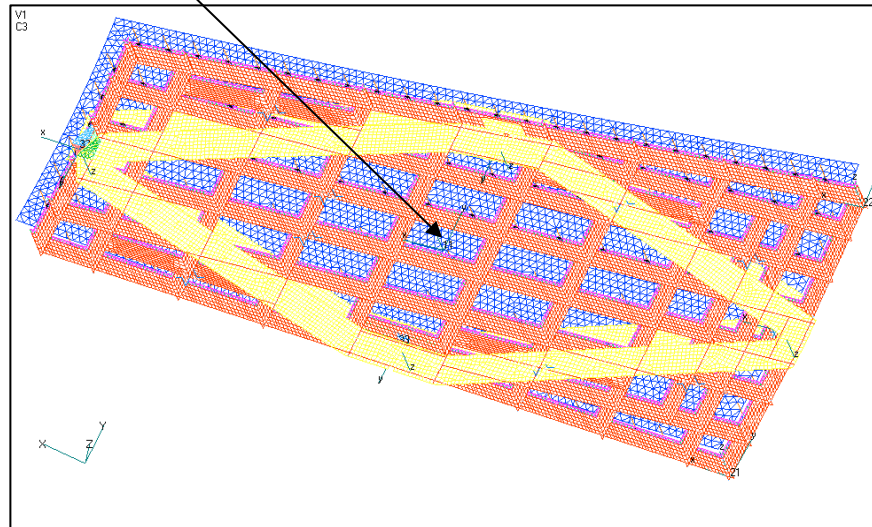

Boundary Conditions, No Subframe

Arrangement 2:

- 8 points at bottom of reaction structure constrained in Z-direction
- 2 points at middle of long sides constrained in X-direction
- 1 point at middle of short side constrained in Y-direction

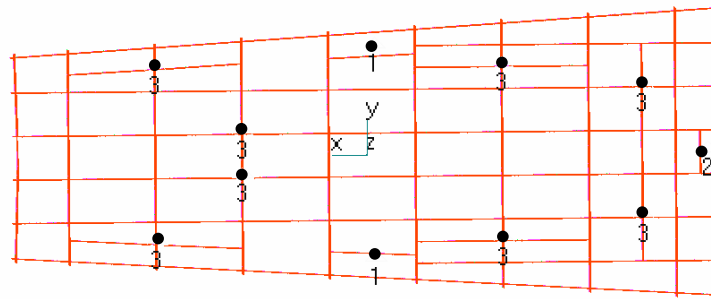

Arrangement 3:

- 8 points at bottom of reaction structure constrained in Z-direction
- 1 point at middle of long side constrained in X-direction
- 2 points at middle of short sides constrained in Y-direction

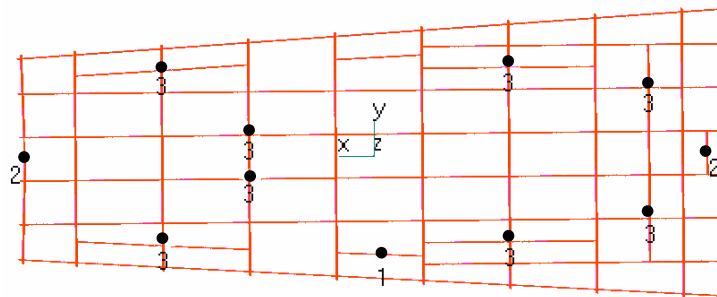

**All constraints
specified in the local
coordinate system 11
(shown)**

Boundary Conditions With Subframe

Arrangement 2:

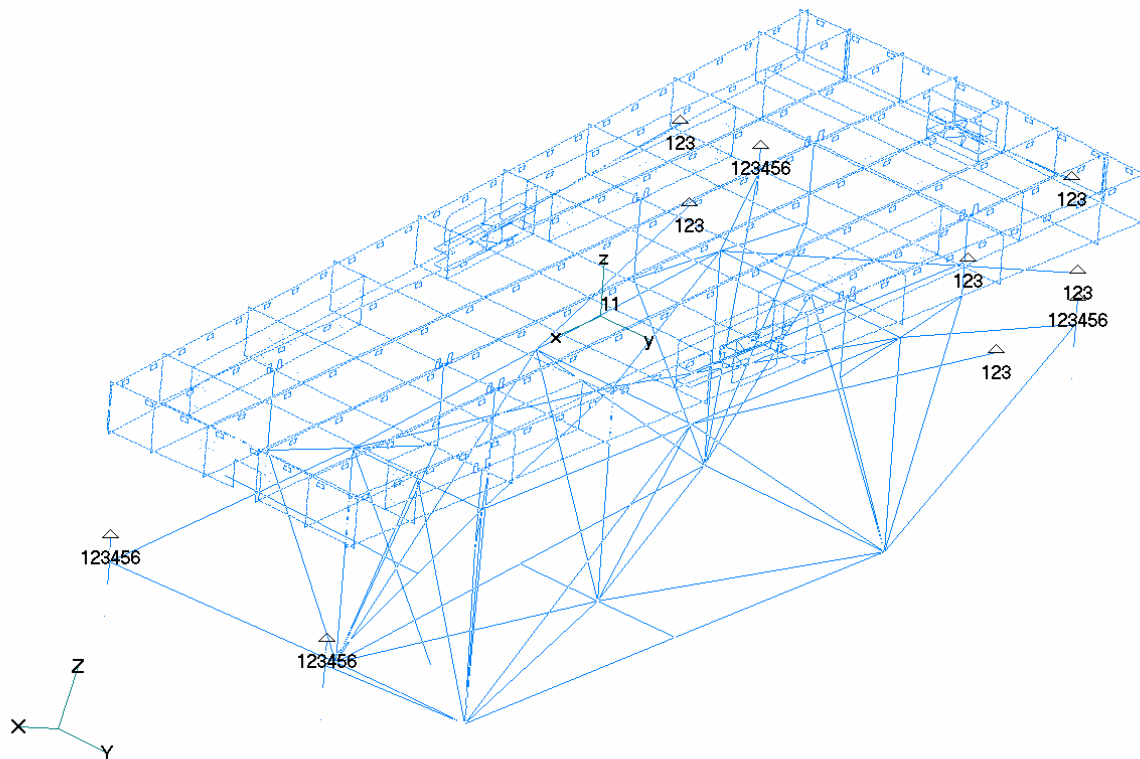

All constraints specified in the local
coordinate system
(coordinate system 11)

Boundary Conditions With Subframe

Arrangement 3:

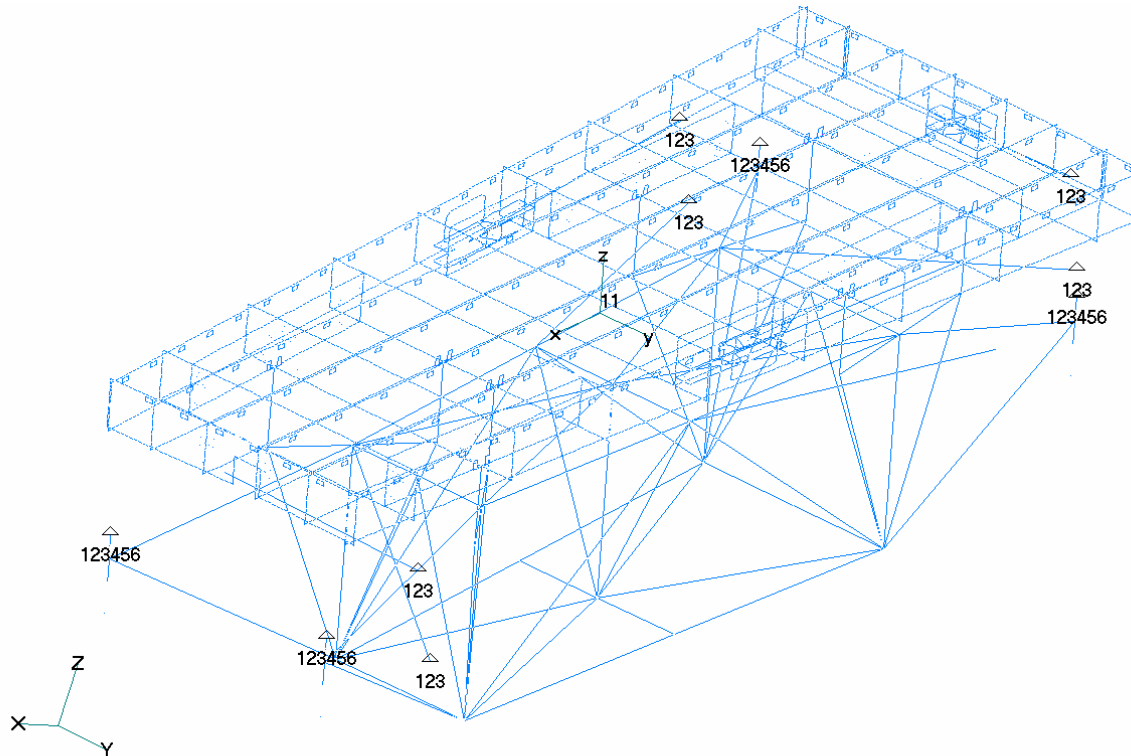

**All constraints specified in the
local coordinate system
(coordinate system 11)**

Coordinate Transformations and Number of Membrane Nodes

Rings 1-4

		Coordinate Transformations				Number of Membrane Nodes
		Local relative to Global (11 relative to 0)		Global relative to Local (0 relative to 11)		
		Translation (in)	Rotation (deg)	Translation (in)	Rotation (deg)	
Ring 1	x	-188.79	0.00	187.62	0.00	5091
	y	0.00	6.74	0.00	-6.74	
	z	1.16	0.00	21.01	0.00	
Ring 2	x	-359.64	0.00	356.42	0.00	5621
	y	0.00	14.57	0.00	-14.57	
	z	33.20	0.00	58.37	0.00	
Ring 3	x	-552.02	0.00	548.80	0.00	4254
	y	0.00	21.66	0.00	-21.66	
	z	96.87	0.00	113.73	0.00	
Ring 4	x	-734.55	0.00	733.87	0.00	5665
	y	0.00	27.86	0.00	-27.86	
	z	180.72	0.00	183.49	0.00	

Rings 1-4 With Subframes

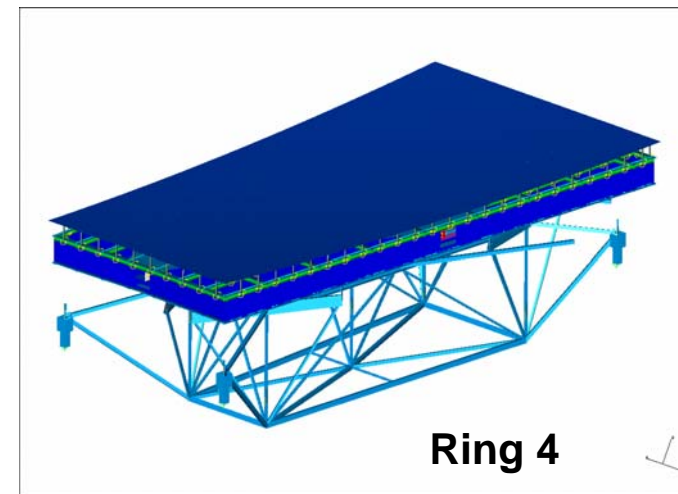
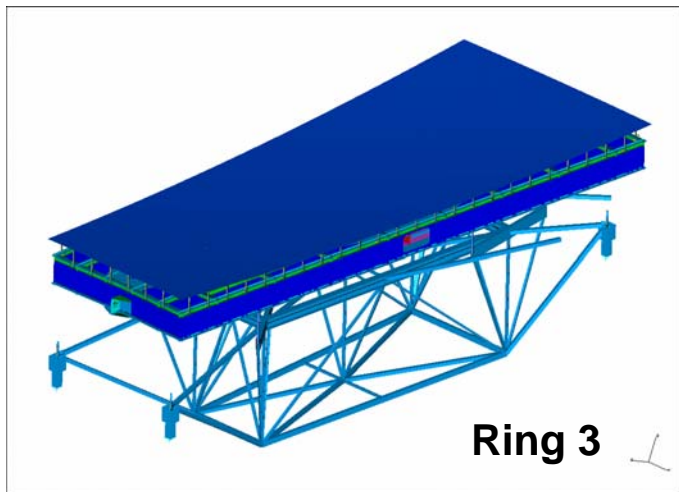
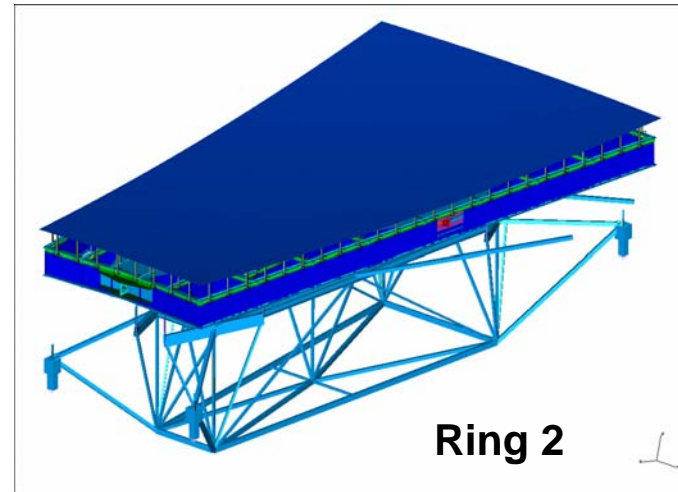
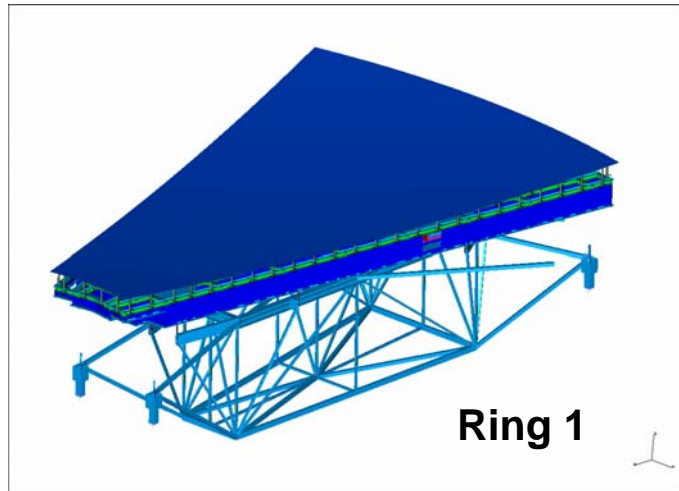

LMT Rings 1-4 Distortion Analysis Results

Ring 1, Telescope Axis Horizontal (E=0), BC2 Best Fit 1/2 Optical Path Residual Error (in) Constrained As Specified

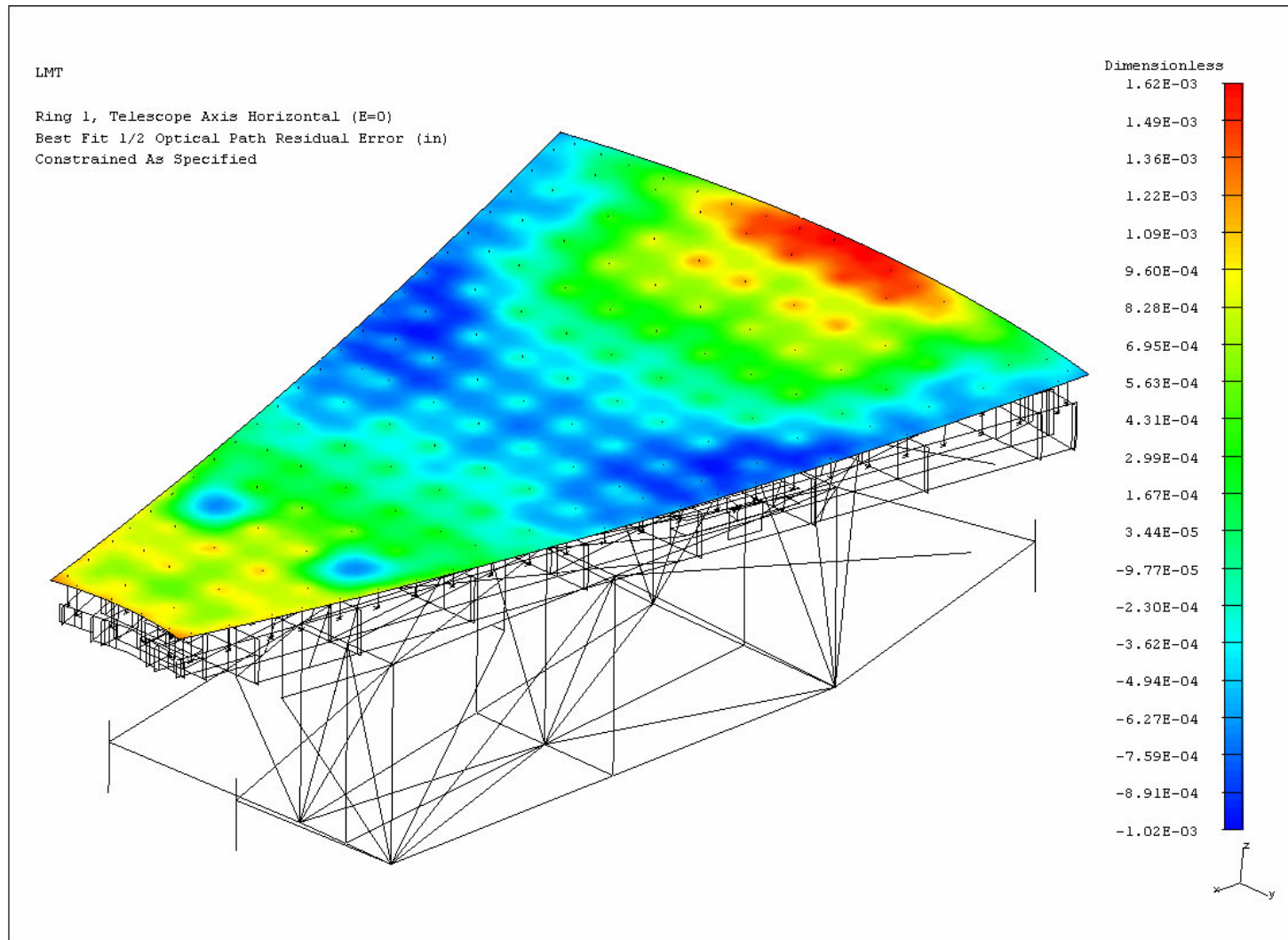

Ring 1 Gravity RMS (microns)

Ring 1 RMS of ½ Path Differences (microns)				
LOAD	Subframe		No Subframe	
	Raw Data RMS	Best Fit surface RMS constrained as specified	Raw Data RMS	Best Fit surface RMS constrained as specified
Gravity Loads in Local Axes, BC2				
1g_X Local, BC2	7.3	1.8	3.4	1.5
1g_Y Local, BC2	17.7	3.8	9.1	3.1
1g_Z Local, BC2	216.4	14.3	19.4	7.7
Gravity Loads in Local Axes, BC3				
1g_X Local, BC3	10.3	2.5		
1g_Y Local, BC3	17.7	4.5		
1g_Z Local, BC3	215.7	13.9		
Change of Elevation – Panel at 12 O'clock, BC2				
Telescope's Axis - Vertical (E=90)	1.5	0.2		
Telescope's Axis – Horizontal (E=0)	240.3	15.6		
Change of Elevation – Panel at 3 O'clock, BC3				
Telescope's Axis - Vertical (E=90)	1.9	0.3		
Telescope's Axis – Horizontal (E=0)	215.2	13.8		

(1) BC2 = Arrangement 2, BC3 = Arrangement 3

(2) Constrained As Specified: Local Z-Motion and X, Y, Rotation Allowed

Ring 2, Telescope Axis Horizontal (E=0), BC2 Best Fit 1/2 Optical Path Residual Error (in) Constrained As Specified

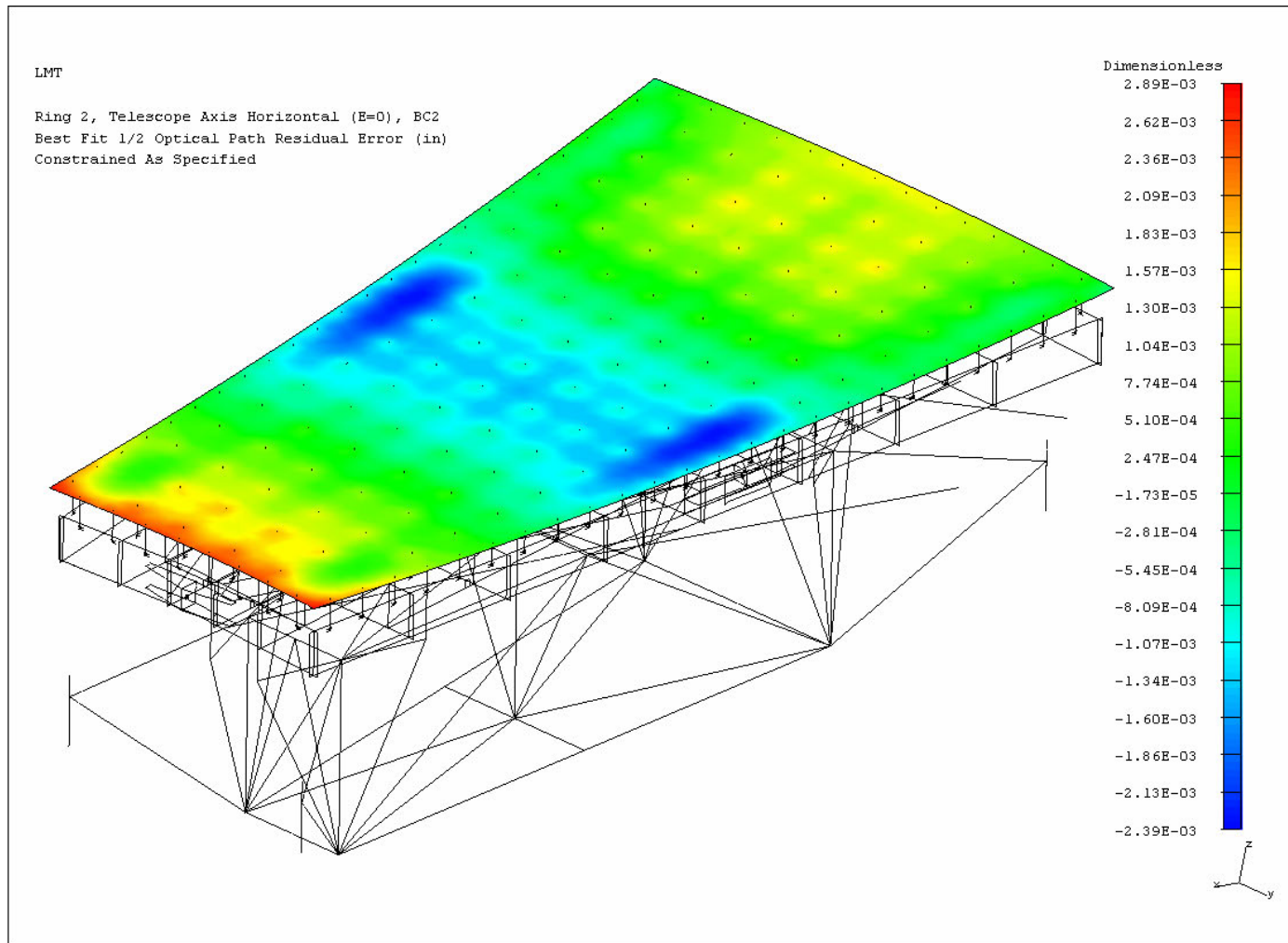

Ring 2 RMS Gravity (microns)

Ring 2 RMS of ½ Path Differences (microns)				
LOAD	Subframe		No Subframe	
	Raw Data RMS	Best Fit surface RMS constrained as specified	Raw Data RMS	Best Fit surface RMS constrained as specified
Gravity Loads in Local Axes, BC2				
1g_X Local, BC2	10.2	2.3	4.9	2.1
1g_Y Local, BC2	30.8	8.9	13.1	5.2
1g_Z Local, BC2	189.3	21.0	23.3	9.2
Gravity Loads in Local Axes, BC3				
1g_X Local, BC3	15.5	6.2		
1g_Y Local, BC3	23.0	4.7		
1g_Z Local, BC3	188.5	20.4		
Change of Elevation – Panel at 12 O'clock, BC2				
Telescope's Axis - Vertical (E=90)	7.3	0.7		
Telescope's Axis – Horizontal (E=0)	240.2	25.5		
Change of Elevation – Panel at 3 O'clock, BC3				
Telescope's Axis - Vertical (E=90)	8.2	1.6		
Telescope's Axis – Horizontal (E=0)	189.0	20.2		

(1) BC2 = Arrangement 2, BC3 = Arrangement 3

(2) Constrained As Specified: Local Z-Motion and X, Y, Rotation Allowed

Ring 3, 1gy Local BC2

Best Fit 1/2 Optical Path Residual Error (in)

Constrained As Specified

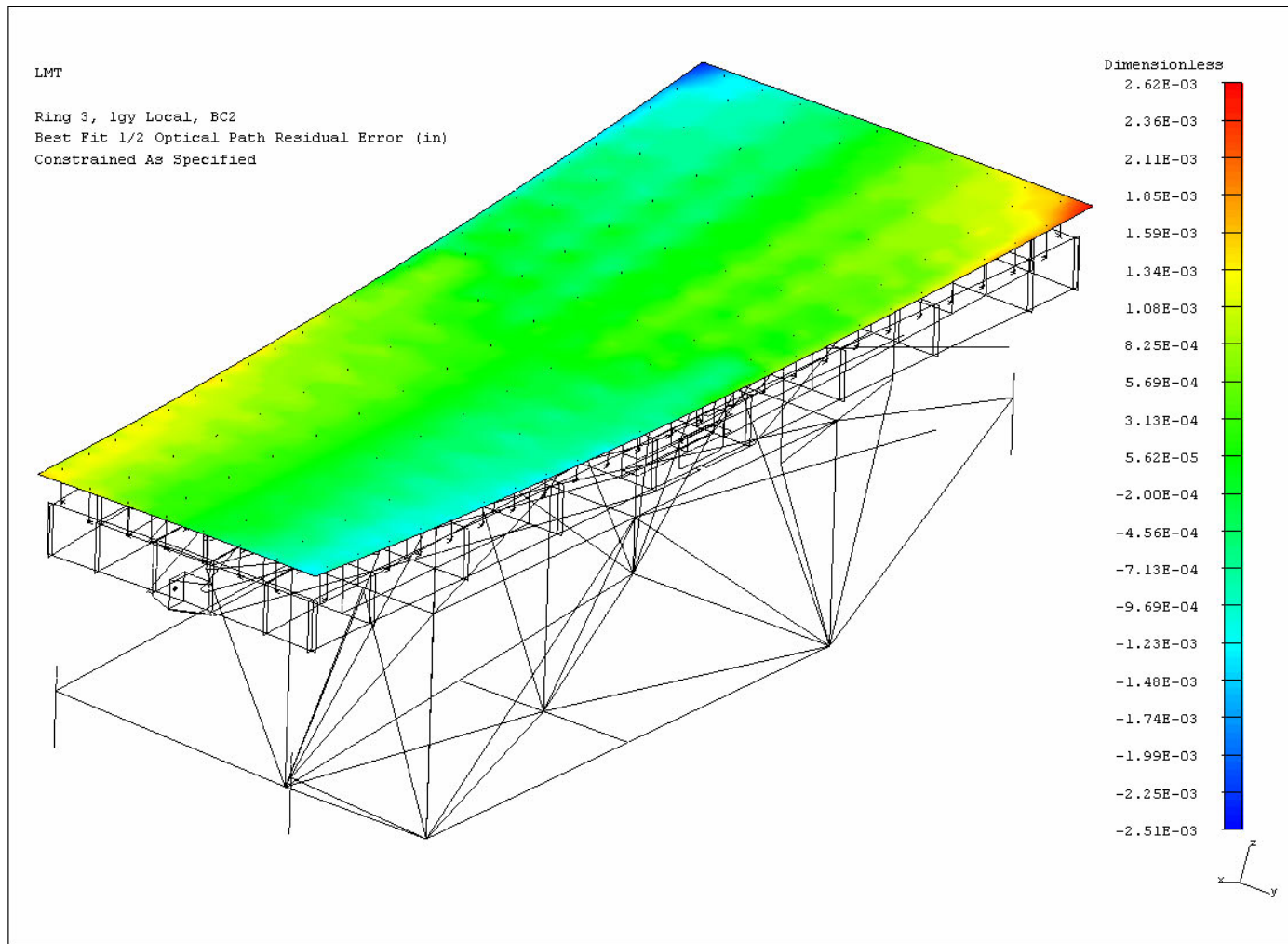

Ring 3 RMS Gravity (microns)

Ring 3 RMS of ½ Path Differences (microns)				
LOAD	Subframe		No Subframe	
	Raw Data RMS	Best Fit surface RMS constrained as specified	Raw Data RMS	Best Fit surface RMS constrained as specified
Gravity Loads in Local Axes, BC2				
1g_X Local, BC2	9.0	2.0	4.6	2.6
1g_Y Local, BC2	30.2	16.2	12.3	8.0
1g_Z Local, BC2	169.6	6.8	20.7	8.0
Gravity Loads in Local Axes, BC3				
1g_X Local, BC3	11.9	4.7	18.1	8.9
1g_Y Local, BC3	15.4	8.5	8.0	5.0
1g_Z Local, BC3	170.1	7.3	23.8	7.8
Change of Elevation – Panel at 12 O'clock, BC2				
Telescope's Axis - Vertical (E=90)	11.9	0.8	2.6	0.8
Telescope's Axis – Horizontal (E=0)	231.2	9.2	30.3	9.8
Change of Elevation – Panel at 3 O'clock, BC3				
Telescope's Axis - Vertical (E=90)	12.5	1.8	8.0	3.3
Telescope's Axis – Horizontal (E=0)	167.0	10.5	23.6	9.6

(1) BC2 = Arrangement 2, BC3 = Arrangement 3

(2) Constrained As Specified: Local Z-Motion and X, Y, Rotation Allowed

Ring 3 RMS Wind and Thermal (microns)

Ring 3 RMS of ½ Path Differences (microns)		
LOAD	No Subframe	
	Raw Data RMS	Best Fit surface RMS constrained as specified
Wind Pressure, 0.00558 psi		
BC2	4.6	1.8
BC3	5.1	1.9
Boundary Condition 2		
Temperature Soak (+20C)	22.1	7.7
Temperature Gradient (+5C)	9.0	6.1
Soak (+20C) + Gradient (+5C)	28.9	9.5
Boundary Condition 3		
Temperature Soak (+20C)	21.7	7.7
Temperature Gradient (+5C)	8.8	6.3
Soak (+20C) + Gradient (+5C)	28.2	9.8

(1) BC2 = Arrangement 2, BC3 = Arrangement 3

(2) Constrained As Specified: Local Z-Motion and X, Y, Rotation Allowed

Ring 4, Telescope Axis Horizontal (E=0), BC2 Best Fit 1/2 Optical Path Residual Error (in) Constrained As Specified

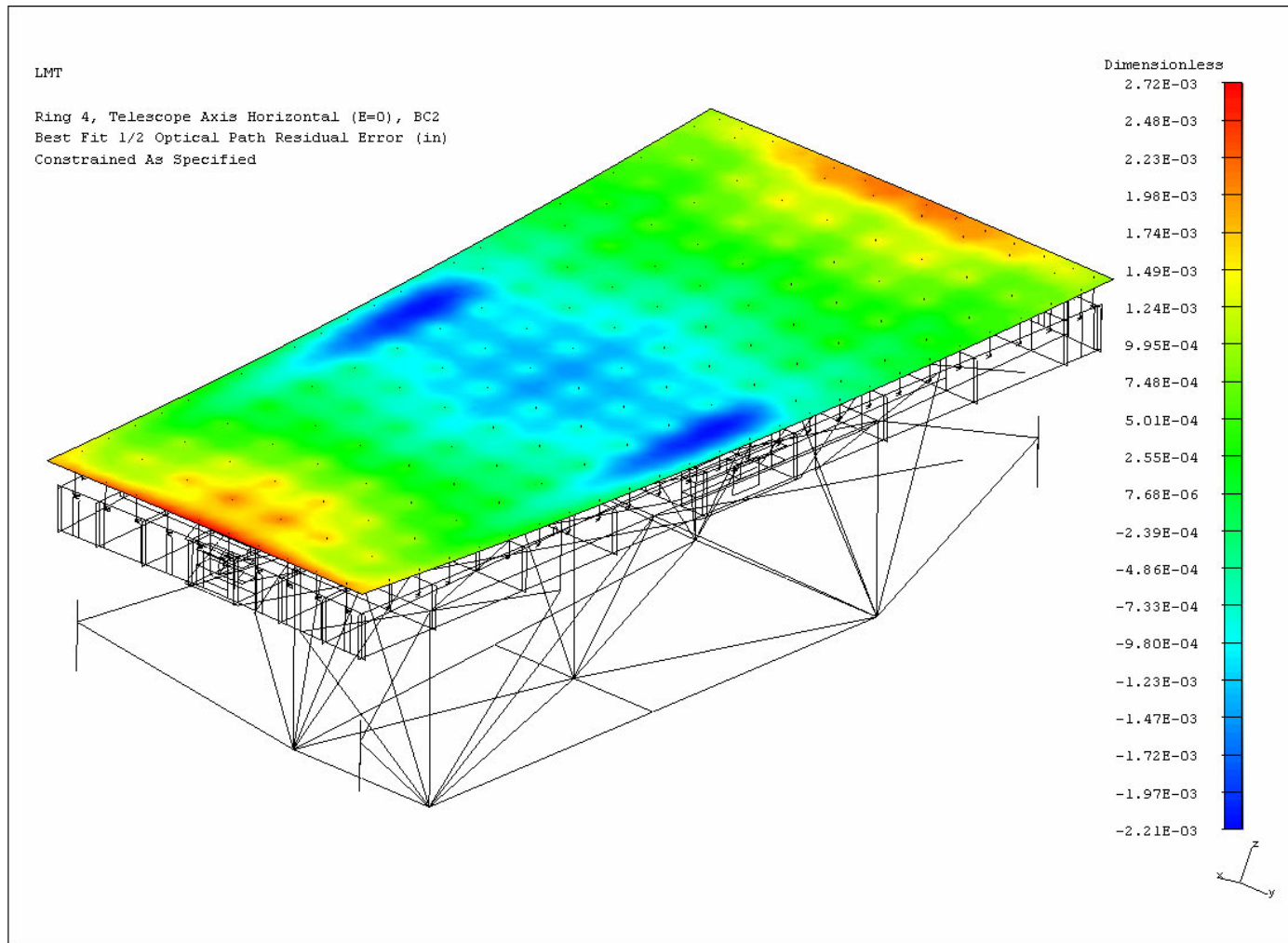

Ring 4 RMS Gravity (microns)

Ring 4 RMS of ½ Path Differences (microns)				
LOAD	Subframe		No Subframe	
	Raw Data RMS	Best Fit surface RMS constrained as specified	Raw Data RMS	Best Fit surface RMS constrained as specified
Gravity Loads in Local Axes, BC2				
1g_X Local, BC2	6.0	1.7	4.2	1.9
1g_Y Local, BC2	23.7	8.8	12.6	4.9
1g_Z Local, BC2	177.4	16.6	15.8	4.9
Gravity Loads in Local Axes, BC3				
1g_X Local, BC3	8.9	4.1	6.0	3.0
1g_Y Local, BC3	13.9	6.0	9.9	4.7
1g_Z Local, BC3	176.9	16.2	15.8	4.9
Change of Elevation – Panel at 12 O'clock, BC2				
Telescope's Axis - Vertical (E=90)	21.3	2.4	2.6	1.1
Telescope's Axis – Horizontal (E=0)	261.4	25.1	23.4	7.3
Change of Elevation – Panel at 3 O'clock, BC3				
Telescope's Axis - Vertical (E=90)	21.9	3.0	3.3	1.5
Telescope's Axis – Horizontal (E=0)	173.9	16.7	18.7	6.7

(1) BC2 = Arrangement 2, BC3 = Arrangement 3

(2) Constrained As Specified: Local Z-Motion and X, Y, Rotation Allowed