



MERLAB, P.C.

Mechanical Engineering Research Laboratory
309 S. McDonough St.
Decatur, GA 30030-3719

Voice: (404) 378-2138
Fax: (404) 378-0822

Title:

Axial Rod Coupling Design

Document Number:

MRLB 32340-01 Issue 0

Release Date:

January 28, 2003

	Name	Date	Signature
Prepared by	David R. Smith	28 Jan 2003	
Approved by	“	28 Jan 2003	
Released by	“	28 Jan 2003	

Report Documentation Page

Form Approved
OMB No. 0704-0188

Public reporting burden for the collection of information is estimated to average 1 hour per response, including the time for reviewing instructions, searching existing data sources, gathering and maintaining the data needed, and completing and reviewing the collection of information. Send comments regarding this burden estimate or any other aspect of this collection of information, including suggestions for reducing this burden, to Washington Headquarters Services, Directorate for Information Operations and Reports, 1215 Jefferson Davis Highway, Suite 1204, Arlington VA 22202-4302. Respondents should be aware that notwithstanding any other provision of law, no person shall be subject to a penalty for failing to comply with a collection of information if it does not display a currently valid OMB control number.

1. REPORT DATE 28 JAN 2003		2. REPORT TYPE N/A		3. DATES COVERED -	
4. TITLE AND SUBTITLE Axial Rod Coupling Design				5a. CONTRACT NUMBER	
				5b. GRANT NUMBER	
				5c. PROGRAM ELEMENT NUMBER	
6. AUTHOR(S)				5d. PROJECT NUMBER	
				5e. TASK NUMBER	
				5f. WORK UNIT NUMBER	
7. PERFORMING ORGANIZATION NAME(S) AND ADDRESS(ES) Mechanical Engineering Research Laboratory 309 S. McDonough St. Decatur, GA 30030-3719				8. PERFORMING ORGANIZATION REPORT NUMBER	
9. SPONSORING/MONITORING AGENCY NAME(S) AND ADDRESS(ES)				10. SPONSOR/MONITOR'S ACRONYM(S)	
				11. SPONSOR/MONITOR'S REPORT NUMBER(S)	
12. DISTRIBUTION/AVAILABILITY STATEMENT Approved for public release, distribution unlimited					
13. SUPPLEMENTARY NOTES See also ADM001773, Large Millimeter Telescope Project. , The original document contains color images.					
14. ABSTRACT					
15. SUBJECT TERMS					
16. SECURITY CLASSIFICATION OF:			17. LIMITATION OF ABSTRACT	18. NUMBER OF PAGES	19a. NAME OF RESPONSIBLE PERSON
a. REPORT unclassified	b. ABSTRACT unclassified	c. THIS PAGE unclassified			

Table of Contents

Revision History	3
0. Applicable Documents	3
1. Summary	4
2. Introduction	4
3. Scope and Objectives	5
4. Performance Specifications	5
5. Design	7
5.1 Upper Rod.....	7
5.2 Lower Rod	7
5.3 Fixed Plug.....	8
5.4 Stop	8
5.5 Coupler.....	8
5.6 Theory of Operation.....	8
5.7. Weight.....	9
6. Loading Assumptions	9
7. Analysis	10
7.1 Rod Calculations	11
7.1.1 Buckling.....	11
7.1.2 Thread Stripping Strength.....	11
7.1.3 Preloading	12
7.2 Bearing (surface) stresses	12
7.2.1 Rod-end Bearing Stresses	12
7.2.2 Stop/Coupler Bearing Stresses.....	12
7.2.3 Bearing Stresses in the Threads	13
7.3 Selection of Lubricants and Thread-locking Compound	14
8. Conclusions and Recommendations	14

Revision History

Rev #	Date	Comments	Signature
0	28 Jan 2003	Initial Release – Ring 5 Only	

0. Applicable Documents

General Reference Drawings from MAN

- AD1 163431-1-1050-2 Panel Layout
- AD2 163431-1-1051-3 Subframe Ring 1
- AD3 163431-1-1052-3 Subframe Ring 2
- AD4 163431-1-1053-4 Subframe Ring 3
- AD5 163431-1-1054-5 Subframe Ring 4
- AD6 163431-1-1055-5 Subframe Ring 5

Final Interfaces

- AD7 Ring 5 Interface Control Document (ICD), COI Drawing #1458395 Rev A
- AD8 Panel axial fitting, COI Drawing #1615515 Rev A
- AD9 Subframe layout, SGH Drawing #JD-1 Rev date 03/01/2002
- AD10 Subframe attachment, SGH Drawing #JD-3 Rev date 03/01/2002

Loads (MAN Documents)

- AD11 WP 32310-01 Iss. 2 Main Reflector Subframes Requirement Specification
- AD12 WP 32320-01 Iss. 8 Main Reflector Panel System Requirement Spec.
- AD13 WP 32320-02 Iss. 5 Main Reflector Panel System FEA Analyses
- AD14 COI Ring 5 Panel CDR Presentation Materials, Mass Summary

Accompanying Drawings

- AD15 MRLB-LMT-1000-1 Axial Rod and Couplings

References

- RD1 MIL-STD-889 Dissimilar Metals
- RD2 Shigley and Mitchell, *Mechanical Engineering Design*, 1983
- RD3 *Machinery's Handbook*, 26th edition
- RD4 www.cda.org.uk/megab2/corr_rs/allybrwe/sec531.htm, quoting a table by Schumacher, W.J. in unpublished works, as well as in "Wear and Galling can Knock out Equipment," *Chemical Engineering*, May 1977
- RD5 Loctite Technical Datasheet, Product 243, April 1998
- RD6 Loctite Technical Datasheets, Moly 50 or Moly Paste, January 2001

1. Summary

This document presents the design and analysis of the axial rods and couplings necessary to connect the LMT reflector panels to their subframes. The axial rod and coupling has been designed to withstand external survival loads (± 8.3 kN (1,870 lb) for Ring 5), and to maintain its length to within 7 microns after disassembly and reassembly. Strength performance has been demonstrated by analysis and repeatability has been demonstrated by testing. The design makes use of standard stock and commercially available parts to reduce cost and speed manufacture, with an estimated cost of \$75 USD per assembly.

2. Introduction

The LMT reflector panel system [AD12] consists of a precision reflector panel supported on a subframe. The subframe, in turn, is supported by the main reflector actuators. An important feature of the design is that the system loads are transferred to the main reflector by means of a decoupled approach. The panel lateral loads are carried directly to the main reflector truss by means of a statically determinate set of lateral bars. A similar set of lateral bars transfers the subframe lateral loads to the main reflector truss. The local vertical loads of the panel are transferred to the subframe via eight axial rods, and the total subframe vertical loads are passed to the main reflector truss through linear actuators.

The separation of local vertical and lateral loads enhances panel performance and simplifies the design requirements on each of the support components. However, the design of the panel and subframe assembly requires that they be separated after precision adjustment and then reassembled on the reflector. No re-adjustment of the panel is possible in the field, so it is essential that the disassembly/reassembly process not change the panel figure. The lateral bar attachments are statically determinate, and so only affect the position of the panel. The four actuator connections are over-constrained, but are under active control and can be adjusted in the field. However, the axial rod connections between the panel and subframe are both over constrained and not actively controllable.

The design shown in this document provides the connection between the panel and subframe. Further, it includes a coupling that has been designed to allow repeatable disassembly and reassembly in the field. Initial connection can be made with one hand, and final tightening requires only standard hand tools. Finally, in the event that a coupling is found to have changed length during the reassembly process, an approach is given for making length adjustments in the field.

3. Scope and Objectives

The design presented in this document (Figure 1) includes the axial rod, the repeatable coupling, and all connection hardware to the panel [AD7] and subframe [AD9]. It specifically does not include any brackets, weldments, or inserts that are permanently attached to either the panel or subframe [AD8, AD10].

4. Performance Specifications

Table 1: Performance Specifications

Requirement	Specification	Source
Maximum Load	± 8.3 kN (1870 lbf) Ring 5	AD11, AD13
Typical load	± 0.6 kN (135 lbf) Weight plus operational wind conditions.	AD14 plus loads from AD11 and 10% margin Uniform load distribution
Repeatability	<7 micron	Experiment
Number of tools required to rough assemble	None	Self-imposed to aid in field assembly
Number of tools required to secure	2 or less	Self-imposed to aid in field assembly
Number of disassembly/reassembly cycles	<20	Estimate
Lifetime	30 years	AD11
Other requirements		
Material	All components except the coupler body are made from 316 Stainless Steel. The coupler is made from 416 Stainless Steel	AD13, coupler changed to prevent galling.

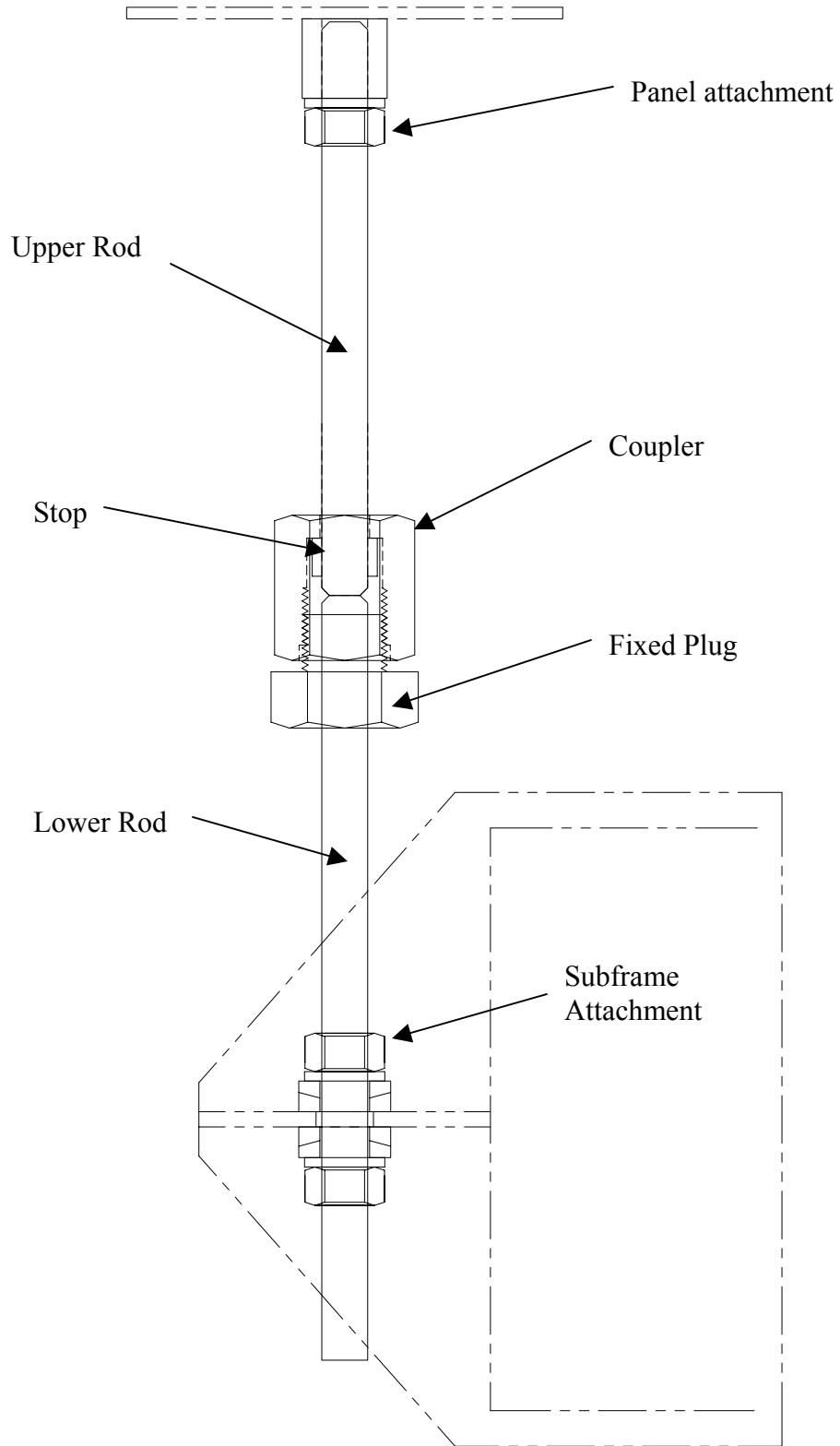

Figure 1: Axial Rod With End Attachments and Coupler

5. Design

The design of the axial rod and coupling is shown in Figure 1. It consists of the following pieces:

Part #	Description
1	Upper Rod
2	Lower Rod
3	Fixed Plug
4	Stop
5	Coupler

5.1 Upper Rod

The upper rod is an M12x1.75 threaded rod, 150mm in length. It threads into an internally threaded fitting [AD8] that is attached to the bottom of the panel reaction structure. The threaded connection is secured using Loctite 243 as well as a standard M12 nut and lock washer. The upper rod, the nut, and the lock washer are all made from 316 stainless steel, as specified by MAN. The lower end of the rod is machined flat, and provides the interface to the lower rod.

5.2 Lower Rod

The lower rod is also an M12x1.75 threaded rod. The exact length depends on which ring the mating subframe is mounted in, but the goal is to choose a few standard lengths so as to reduce the number of distinct parts in the telescope. The lower rod passes through a 15mm hole in a flange on the subframe [AD10], and is captured from both sides by a standard M12 nut, a lock washer, and a spherical washer set. The spherical washer allows the assembly to accept slight angular misalignments, while the oversized hole in the subframe flange allows for the corresponding lateral misalignments. In addition to the lock washers, the use of Loctite 243 on the M12 nuts is recommended. The lower rod, M12 nuts, and lock washers are made from 316 stainless steel. The spherical washers are made from generic 18-8 stainless steel, due to more limited availability of materials in standard parts. The upper end of the rod is machined flat and provides the precision interface to the upper rod.

5.3 Fixed Plug

Nominally, the fixed plug consists of a 7/8"-9 UNC fully-threaded standard bolt, 15mm in length, with an M12x1.75 through-hole in the center. However, in production, this piece can be machined from hexagonal stock if preferred. As with the upper and lower rods, this piece is made from 316 stainless steel. The fixed plug is threaded onto the lower rod, to the approximate position shown in AD15, and secured with Loctite 243. During final assembly, the coupling nut is tightened onto the outer threads of this plug and also secured with Loctite 243.

5.4 Stop

The stop is a 17mm (or 11/16") diameter cylindrical piece, 10mm in length, with an M12x1.75 through-hole in the center. It is made from 316 stainless steel. The Stop is threaded onto the upper rod and secured with Loctite 243.

5.5 Coupler

The coupler is a single machined piece that slides on the upper rod and provides a standard 7/8"-9 UNC threaded interface to the fixed plug. Since this piece has a loaded, sliding interface with the stop and the fixed plug, it should be made from 416 stainless steel to prevent galling at the interface.

5.6 Theory of Operation

To tighten the coupling, the coupler is tightened against the fixed plug. The upper shoulder of the coupler presses against the stop, and the outer threads of the fixed plug provide the means for tightening the assembly. The final length of the assembly depends only on the machined interface between the upper and lower rods; the quality of the threads in the coupling is irrelevant.

The design is such that even if the internal threads on the fixed plug or the stop were left loose, the assembly would still tighten because of the greater lead on the outer threads of the fixed plug. However, by securing them with a thread-locking compound, they provide a more stable assembly.

In order to protect against corrosion, the entire assembly is made from non-corrosive materials. Further, all materials have been chosen to have nearly the same galvanic index (RD1), to prevent moisture-induced corrosion between mating pieces. Since stainless steel is susceptible to galling under sliding contact, all critical interfaces with this type of contact have differing materials, and a molybdenum-based grease may be employed to further reduce this tendency.

5.7. Weight

The weight of the components and assembly are summarized in Table 2 below.

Table 2: Axial Rod and Coupling Weights (Ring 5)

Part	Mass (g)	Number	Total (g)	Total (lb)
Short Rod (150mm)	108.7	1	108.7	0.24
Long Rod (200mm)	144.7	1	144.7	0.32
Stop	10.9	1	10.9	0.02
Fixed Plug	116.2	1	116.2	0.26
Coupler	161.5	1	161.5	0.36
M12 nut	15.5	3	46.5	0.10
Lockwasher	3.8	3	11.4	0.03
Spherical Washer set	31.5	2	63.0	0.14
Total			662.9	1.46

6. Loading Assumptions

The expected loads on the axial rods can be found in the MAN analyses in documents WP 32320-01 Issue 8 (p. 23) (AD12) and WP 32320-02 Issue 5 (Table 2.3.1, p. 49, Table 2.4.1, p. 58) (AD13). However, there are some problems with using the reported values. The most significant problem is that the loads are not consistent between the documents. According to document WP 32320-01 Issue 8, the maximum compressive load on the axial rods occurs in ring 5 and it is $-4,527.1$ N. However, according to document WP 32320-02 Issue 5, the maximum compressive load in the axial rods is $-8,252.3$ N. While it is still reported to occur the ring 5 assembly, this is a factor of 1.8 higher. The higher value is corroborated in AD11. To further complicate matters, the peak load in both documents is said to occur for survival load case 13, which corresponds to the following case: *1.35 Gravity load (Z) + 1.5 Wind Load (positive) + 0.75 Ice Load (Z)*.

As MAN notes on p. 62 of WP 32320-02 Issue 5, this load case is non-physical, because the antenna must be stowed to reach survival load capability. Thus, the loads given are inconsistent and also do not reflect a real loading condition on the antenna. A second problem with the analysis is that MAN has done the calculation based upon the peak stress in the axial supports. As a result, the critical case shows up in ring 5, because the ring 5 panel has the largest area and thus the largest wind, ice, and gravity loads. However, because of variations in the details of the subframe/panel connections, the axial rods are significantly longer in rings 1-3. Since buckling of the axial rods depends strongly on the length of the rods, it is not clear that the ring 5 case will be the critical case in terms of buckling.

As of the first release of this document, we do not have complete information on the free lengths of the axial rods for rings 1-4. However, the ring 5 panel is shown to be within the buckling specifications (Appendix A).

7. Analysis

The design dimensions for the rod and coupling come from the specifications. A summary of the rationale for the design details is shown in Table 3. Essentially, the rod diameter is determined by its buckling limit, and the remaining components are sized to provide the same strength. The diameter of the coupling components are determined by the diameter of the stop, which has been sized to support the bearing stresses caused by tightening the connections. Summary calculations for each of the sections here are available in Appendix A.

Table 3: Driving Constraints for Design Features

Feature	Driving Specification or Constraint
<i>Upper and lower rods</i>	
Rod length	Panel/Subframe separation distance, as given by drawings from MAN, COI, and SGH (AD1-AD10).
Rod diameter	Buckling load. See calculations.
Rod material	Specified by MAN (corrosion protection), AD13
<i>Fixed plug</i>	
Diameter	Matches coupler, large enough to allow passage of the stop on the upper rod
Length	Minimum 10 mm engaged length (see calculations), plus clearance to allow variations in assembly
Thread	Size consistent with diameter and coupling nut.
Material	Corrosion protection to match AD13
<i>Stop</i>	
Diameter	Bearing stresses from the coupler. See calculations.
Length	Provide identical strength to the full rod in tension. See calculations.
Material	Corrosion protection to match AD13
<i>Coupler</i>	
Inner diameter	Consistent with clearance for stop.
Thread	Smallest standard size consistent with diameter.
Length	Smallest standard length that still allows room for the two plugs and the stop.
Material	Chosen for corrosion resistance, cost, machinability, and galling compatibility with mating pieces.
<i>Thread-locking Compound</i>	
Thread-locking Compound	For use with stainless steel, and allowing disassembly with hand tools.
Lubricants	For use with stainless steel connections.

7.1 Rod Calculations

7.1.1 Buckling

As shown in AD11, the maximum compressive survival load on the axial rods for Ring 5 is 8.3 kN. Additionally, the material has been chosen (AD13), and the free length of the rod has been set by the panel and subframe (AD8, AD10). This information is sufficient to determine the minimum diameter of the axial rod. Specifically, the material choice (316 stainless steel) establishes the modulus $E = 193 \times 10^3 \text{ N/mm}^2$ ($28 \times 10^6 \text{ psi}$), and the free length of the rod is given by the distance between the panel and subframe interface surfaces (265 mm for Ring 5).

It is worth noting that the ends of the rod are fixed against rotation, and the center section of the rod includes a large diameter coupling. Both of these features will increase the critical buckling load (P_{cr}) of the rod. Specifically, the coupling diameter will locally increase the cross-sectional area moment of inertia (I), and the end connection hardware will both increase the end condition constant (C) and reduce the free length. However, to be conservative, we ignore the coupling and assume that the rod is free to pivot at both ends. No additional factor of safety has been used here, because the peak loads have already been determined using the load factors for the survival conditions, which include safety margins. The governing calculation indicates that the minimum standard size for the threaded rod for Ring 5 is M12. It is likely that the other rings will be able to use the same type of threaded rod, but confirmation of this may require a more detailed analysis to account for the stiffening effects described above. In any event, these cannot be checked until the final free length dimensions are known.

7.1.2 Thread Stripping Strength

Since buckling resistance establishes the rod diameter, it is no surprise that the rod is much stronger in tension. The tensile area (A_t) for an M12x1.75 rod is 84.3 mm^2 [RD2], and the yield strength (S_y) of 316 stainless steel is 240 N/mm^2 (35 ksi) [RD3]. This indicates that the maximum static tensile load that the rod can support is 20.2 kN (4,500 lbf).

Designing the threaded connections to match this strength requires a length of engagement (L_e) of at least 10 mm for the M12 threads and 5.3 mm for the 7/8"-9 UNC threads. For the 7/8"-9 UNC threads, the calculated length is less than the standard practice of a minimum engagement of three threads. Three threads of a 7/8"-9 UNC bolt requires a length of 8.5 mm, so again we choose 10 mm as the nominal engagement length.

7.1.3 Preloading

In order to guarantee that the rod ends never separate, the connection must be preloaded. It is not necessary to preload the connection to the expected maximum external load to guarantee this condition, because the external loads mostly pass through the body of the coupler rather than through the rod interface [RD2]. Choosing a preload sufficient to guarantee that the coupler remains in tension and the rod interface remains in compression results in a preload of 7 kN, which corresponds to a torque of about 31 N m (23 lbf-ft) on the 7/8"-9 coupling. While the actual preload caused by this torque will vary substantially in the field, this torque value is high enough to prevent joint opening and low enough not to exceed the yield strength of the rods, even in the presence of such practical variations.

IMPORTANT NOTE: two wrenches must be used to tighten the connection: one on the fixed plug and one on the coupler. The axial rods themselves have not been designed to withstand the tightening loads and will break if the reaction is not taken at the fixed plug.

7.2 Bearing (surface) stresses

There are three types of surface stresses that are important in the design of the coupling. These are the bearing stresses on the rod interface, the stop/coupler interface, and the threads.

7.2.1 Rod-end Bearing Stresses

In the rod interface, the calculation is simple because there are two flat circular areas held in compression by the coupling. There is no sliding contact, so there is no issue of galling at this interface. Even with a 2mm chamfer on the M12x1.75 rod, this area has a diameter of about 8mm, so the maximum allowable compression stress has been calculated to be 12 kN (2,700 lbf). This is well in excess of the maximum load carried through this interface, which is not surprising given that the rod diameter is governed by buckling resistance.

7.2.2 Stop/Coupler Bearing Stresses

At the interface between the coupler and the stop, there are direct bearing stresses on an annular region. More importantly, these stresses are developed during tightening of the connection, when there is sliding between the two surfaces, which raises the possibility of galling. For the sliding plug to move freely on the axial rod, it must have at least a 13mm diameter through hole. This sets the inner diameter of the annular region, and the outer diameter of the stop establishes the outer diameter. As shown in the calculation below, the minimum diameter for the stop to reach the full strength of the rod is 16.6 mm. To use standard sizes, the stop can be made from either 17mm or 11/16" (17.46mm) round stock.

The bearing stress at this interface during tightening of the connection has been calculated to be approximately 94 N/mm² (13.6 ksi). This is well in excess of the threshold galling stress of 13.8 N/mm² for 316 stainless steel acting on itself, and is the principal factor in choosing an alternate material for the coupler. This stress level is well within both the yield strength of the material (240 N/mm²) and the threshold galling stress of 290 N/mm² for 416 stainless steel acting on 316 stainless steel under sliding conditions (RD4). Even so, a lubricant suitable for stainless steel (e.g., molybdenum grease) should be used at this interface.

7.2.3 Bearing Stresses in the Threads

There are four threaded interfaces in the coupling, as well as threaded interfaces at the connections to the panel and subframe. As summarized in Table 4, the critical case for the M12x1.75 threads is at the end connections, because they have comparable engagement length with the threaded stop, but are loaded by tightening, resulting in a sliding contact under load. The only case for the 7/8"-9 UNC threads occurs between the coupler and the fixed plug; this connection also has sliding contact during tightening.

Table 4: Threaded Interfaces

Interface	Condition
<i>Coupling</i>	
M12x1.75 threads at stop	10mm length, non-rotating under load
M12x1.75 threads at fixed plug	>25mm length, non-rotating under load
7/8"-9 UNC threads between fixed plug and coupling nut	~10mm length, sliding contact during load
<i>End connections</i>	
M12x1.75 threads in nut	10mm length, rotating/sliding contact during tightening.

The peak bearing stress on the M12x1.75 threads in the connection nuts, assuming that they are tightened to a preload of no more than 15 kN (3,370 lbf) is 64 N/mm² (9.3 ksi). This preload corresponds to 75% of the yield strength of an M12 rod, which is within the range recommended in RD2. To avoid exceeding this value, the preload torque to achieve this load would be at most 35 Nm (26 lbf ft). Though the end connections are intended to be permanent, this load is in excess of the threshold galling stress, so a lubricant suitable for use on stainless steel fasteners should be employed on each of these connections (e.g., molybdenum grease). The peak bearing stress under non-sliding load is 95.8 N/mm² (13.9 ksi), which is within the yield limit of the material, as expected from the axial strength and thread strength calculations.

The peak bearing stresses at the interface between the fixed plug and the coupling nut are shown below to be 11.8 N/mm^2 (1.7 ksi) for an engagement length of 10mm and a preload of 4.6 kN (1,050 lbf). This is much less than the threshold galling stress of 416 stainless steel acting on 316 stainless. The maximum static bearing stress (in a non-sliding condition) for this interface is 52 N/mm^2 (7.5 ksi), which is much less than the yield strength for either of these materials (RD3).

7.3 Selection of Lubricants and Thread-locking Compound

The lubricants and thread-locking compounds are those recommended by Loctite corporation for use with stainless steel parts (RD5 and RD6).

8. Conclusions and Recommendations

The design presented here provides an axial rod and coupling that provides proper separation between the reflector panel and subframe and also allows repeatable disassembly and reassembly. There is an unresolved issue in the design that is beyond the scope of this work. Specifically, the effect of angular misalignment from the connection to the reaction structure on the repeatability of the coupling has not been investigated.

A simplification to the design would be possible if the axial fitting at the panel reaction structure could be modified. In the proposed modification, the fitting that extends from the reaction structure would have the end ground flat and would have the outside threaded. This would eliminate the upper rod and fixed plug. Implementation of this recommendation would require a change to the existing fitting design, however, which is beyond the scope of this document. It is also worth noting that implementation of this recommendation would still have the same unresolved issue described in the previous paragraph.

MRLB 32340-01 Issue 0

Appendix A

Calculations

A.1. Buckling

The general formula for the critical load P_{cr} under Euler buckling [RD2] is

$$P_{cr} = \frac{C\pi^2 EI}{l^2}$$

and the general formula for the critical load for short column failure (J.B. Johnson theory) [RD2] is

$$P_{cr} = AS_y - \frac{A}{CE} \left(\frac{S_y}{2\pi} \right)^2 \left(\frac{l}{k} \right)^2.$$

For both of these formulas, C is the end condition constant (taken to be 1.0 for pinned-pinned beams), I is the cross-sectional area moment of inertia, E is Young's modulus for the material, l is the free length, A is the cross sectional area, S_y is the yield stress of the material, and k is the radius of gyration of the section. The Johnson formula applies when the slenderness ratio l/k is below a threshold value

$$\left(\frac{l}{k} \right)_1 = \sqrt{\frac{2\pi^2 CE}{S_y}}.$$

For the LMT axial rods, which are made from 316 stainless steel and have circular cross-section, the various parameters are as follows [RD3]:

$$C = 1 \text{ (conservative)}$$

$$E = 193,000 \text{ N/mm}^2$$

$$S_y = 240 \text{ N/mm}^2$$

$$I = \frac{\pi d^4}{64}$$

$$A = \frac{\pi d^2}{4}$$

$$k = \frac{d}{4}$$

For Ring 5, $l = 265$ mm, so

$$\left(\frac{l}{k}\right)_1 = 126.$$

Assuming a slender column reveals that the minimum rod diameter is

$$d_{\min} = \sqrt[4]{\frac{64P_{cr}l^2}{C\pi^3E}} = 8.89 \text{ mm}.$$

However, this results in $l/k = 119$, which is less than the threshold value, so the axial rod for Ring 5 acts as a Johnson column, thus

$$d_{\min} = 2\sqrt{\frac{P_{cr}}{\pi S_y} + \frac{S_y l^2}{C\pi^2 E}} = 8.91 \text{ mm}.$$

Not surprisingly, since we are near the cross-over between and Euler column and a Johnson column, the results are nearly identical. Taking the most conservative approach, we compare this diameter to the minor diameter of the threaded rod, and assume rounded form threads (which produces the smallest minor diameter). The smallest standard series metric thread that meets or exceeds this diameter is M12x1.75, which has a minor diameter of at least 9.601 mm [RD3]. With this diameter, the rod can support a compressive load of $P_{cr} = 10.7$ kN.

A.2. Thread Stripping Strength

The threads on the M12x1.75 rod will strip when the shearing stresses exceed the shear yield strength S_{sy} . An approximate formula for the total shear area between a nut and bolt of similar yield strength is [RD2]

$$A_s = \frac{\pi d_m L_e}{2}$$

where d_m is the pitch diameter of the threads and L_e is the engagement length. This suggests that the maximum load that can be carried before stripping is

$$F_{\text{strip}} = S_{sy} \frac{\pi d_m L_e}{2},$$

or, using the maximum shear stress failure theory, so $S_{sy} = S_y/2$,

$$F_{\text{strip}} = \frac{S_y \pi d_m L_e}{4}.$$

For this load to match the maximum axial strength of the rod, this must also be equal to the maximum axial force

$$F_{\text{axial}} = S_y A_t.$$

Since the rod and stop are made from the same material, this simplifies to

$$A_t = \frac{\pi d_m L_e}{4},$$

so

$$L_e = \frac{4A_t}{\pi d_m}.$$

For an M12x1.75 rod, the pitch diameter is 10.7 mm, and the tensile area is 84.3 mm² [RD2], so the necessary engagement length is 10 mm. Not surprisingly, this is approximately the same as the standard height for an M12x1.75 nut.

For the 7/8"-9 UNC threads to have the same strength as the M12x1.75 rod, we use the pitch diameter of the 7/8"-9 thread and the tensile area of the M12x1.75 thread, resulting in $L_e = 5.3$ mm. The coupler side of this connection is made from slightly stronger material than the fixed plug, but this does not significantly change the calculation.

A.3. Preload

A.3.1. Preload in the Coupler

To calculate the necessary preload on the connection, it is necessary to account for the stiffnesses of the coupler and the rod as a pair of springs acting in parallel. This is exactly the same as calculating for a preloaded bolted connection. Using the notation from RD2, we see that

$$k_b = \frac{A_t E_b}{L}$$

and

$$k_m = \frac{A_c E_m}{L}.$$

The ratio of the stiffnesses within the coupling is

$$\alpha = \frac{k_b}{k_m} = \frac{A_t E_b}{A_c E_m}$$

A_t for the M12x1.75 bolt is 84.3 mm² [RD2]. For the coupler, we assume conservatively that the area in the coupling is the area of the hexagonal coupler minus the area of a central hole, taken to be the major diameter of the internal threads. Thus,

$$A_c = \frac{\sqrt{3}h^2}{2} - \frac{\pi d^2}{4}$$

where $h = 1.25'' = 31.75$ mm and $d = 0.875'' = 22.22$ mm resulting in

$$A_c = 485 \text{ mm}^2.$$

This indicates that the coupler stiffness is much higher than the bolt stiffness. This is important, because the total compressive force in the bolt and tensile force in the coupler, given a preload of F_i and an external load P follows the equation

$$F_b = -F_i + \frac{k_b}{k_b + k_m} P$$

$$F_m = F_i + \frac{k_m}{k_b + k_m} P$$

or

$$F_b = -F_i + \frac{\alpha}{1 + \alpha} P$$

$$F_m = F_i + \frac{1}{1 + \alpha} P$$

For a stainless steel coupler, $E_b = E_m$, so we have a stiffness ratio of

$$\frac{k_b}{k_m} = 0.1738,$$

so this reduces to

$$F_b = -F_i + 0.148P$$

$$F_m = F_i + 0.852P.$$

Thus, in order to prevent the joint from opening under tension, the preload must be at least 0.148 times the expected tensile load, and to prevent the coupler threads from loosening, the preload must be at least 0.852 times the expected compressive load. In this case, the governing case is the compressive load, which is 8.3 kN [AD11], after accounting

for all safety factors. While the load case that produces this value is non-physical, this suggests that a preload of at least 7 kN is appropriate.

An approximate relation between torque and preload is given by

$$T \approx KF_i d$$

where K is a joint constant (typically around 0.2), F_i is the desired preload, and d is the nominal diameter of the bolt. For this case, we find that an appropriate torque is

$$T \approx 31 \text{ N} \cdot \text{m} = 23 \text{ ft} \cdot \text{lbf}.$$

While there will be a fair amount of variability in the actual preloads, the use of a thread locking compound will assist in preventing loosening of the joint even if the compressive load completely relaxes the preload in the threads. Because the maximum tensile load is not as large, and because most of the load variation is taken by the coupler, there is an extremely large margin of safety against the joint ever opening. In fact, in order to separate the rod ends with this preload, the external force would have to reach 47 kN, which is beyond the axial failure of the rod.

Because of this large margin of safety against the critical purpose of the coupling, and because the survival compressive loads are by no means a fatigue issue. As a result, the preload could be reduced substantially if it proves difficult to reach this value in the field.

Important Note: Two wrenches must be used in tightening the connection: one to hold the fixed plug and the other to tighten the coupling against it. The axial rods themselves are not designed to support the tightening loads, and they will fail if the coupler is torqued to this level.

A.3.2. Preloading at the End Connections

Since the end connections are designed to be permanent connections, they should be preloaded to at least 75% of the yield strength of the M12x1.75 rod [RD2]. That is, they should be torqued to provide a preload of

$$F_i = 0.75A_t S_y = 15 \text{ kN}.$$

This corresponds to a torque of approximately

$$T \approx 0.2(15 \text{ kN})(12 \text{ mm}) = 35 \text{ N} \cdot \text{m} = 26 \text{ ft} \cdot \text{lbf}.$$

A.4. Bearing Stresses

A.4.1. Rod Interface

At the rod interface, even assuming a 2mm chamfer, the clear area for the interface is 8mm, for a total area of 50.3 mm². This allows a maximum compressive load of

$$P_{\max} = AS_y = 12 \text{ kN},$$

which is greater than the critical buckling load of the rod, and greater than the stress induced by the preload.

A.4.2. Coupler/Stop Interface

The interface between the coupler and the rod is an annular region with an inside diameter set by the through hole in the coupler (13 mm) and the outside diameter set by the O.D. of the stop. For this interface to be as strong as the rod itself, it must have at least the same area. Since the tensile area of the rod is 84.3 mm², this implies that

$$\frac{\pi(d_o^2 - 13^2)}{4} = 84.3$$

so the outer diameter of the stop must be at least

$$d_o = 16.6 \text{ mm}.$$

Choosing the nearest standard size results in 17 mm for metric stock, and 11/16" (17.46 mm) for English stock. To be conservative, we assume the use of 17mm stock, which results in an area of 94 mm², and can sustain a total load of 22.6 kN. Further, from the equations in the preload section, we see that to reach this level of force on the stop would require an external tensile load of about 18 kN, which is well in excess of the predicted survival loads. This is not surprising, since this design matches the tensile strength of the rod, while the limiting loads are governed by buckling.

The stress during tightening to the ≈ 7 kN preload torque will be on the order of 75 MPa, which is well below the threshold galling stress for 416 stainless on 316 stainless (290 MPa, according to RD4).

A.4.3. Threaded Interfaces

The bearing stresses on a set of threads with length of engagement h is given by RD2 as

$$\sigma \approx \frac{-4Fp}{\pi h(d^2 - d_r^2)}$$

where p is the pitch of the screw, d is the major diameter, and d_r is the root (minor) diameter.

A.4.3.1. End Connections

For the end connections, the preload will be on the order of 15 kN, and the height of the nut is about 10 mm. This suggests an average bearing stress on the threads of 64 MPa. This is well in excess of the threshold galling stress for 316 stainless steel acting on itself [RD4]. This confirms that even though the end connections are intended to be permanent, they should be well lubricated with a moly-based grease to prevent galling.

A.4.3.2. Stop and Fixed Plug M12 Threads

These threads do not undergo sliding under load, and so only need to be checked for stress rather than galling. The maximum load on the stop is comparable to the load in the end connection nuts, and the stop has the same engagement length, so the stresses are about 64 MPa. This is much less than the 240 MPa yield strength of 316 stainless steel. Since the fixed plug has a longer engagement length, the stresses should be even lower.

A.4.3.3. Coupler and Fixed Plug Interface

Since the threaded interface between the coupler and fixed plug experiences sliding during preload, it must be checked against both yield and galling. In this case, the average bearing stresses on the threads are about 25 MPa. This is well below both the yield stress and the threshold galling stress for 416 stainless acting on 316 stainless. The load can be about twice this value under maximum tensile load (though this occurs without sliding), but the stress level would still remain well below the limits.

REVISIONS				
ZONE	REV	DESCRIPTION	DATE	APPROVED
-	B	Redesigned for single piece coupler	18 Nov 02	DRS
-	0	Initial Formal Release, notes added	25 Nov 02	DRS
-	1	Manufacturing notes added	23 Jan 03	DRS

ASSEMBLY DIMENSIONS		
Ring #	"A"	"B"
1	TBD	TBD
2	TBD	TBD
3	TBD	TBD
4	TBD	TBD
5	350	265

Ring#	"L"	Qty
1-4	TBD	1056
5	200	384

NOTES:

- Grind both ends flat to tolerance, OR clearly mark non-precision end.
- Runout of ground face taken at maximum radius.

-1, -2

GENERAL NOTES:

- Break all corners and sharp edges
- End attachment hardware must be included, as shown in bill of materials.
- During pre-assembly, use Loctite 243 between the upper threaded rod (-1) and upper stop (-4), as well as between the lower threaded rod (-2) and the fixed plug (-3). Installation position of the fixed plug (-3) should permit assembly of the connection without closing the gap between the coupler (-5) and the fixed plug (-3).
- During final assembly, use a Molybdenum-based anti-seize compound on the connections to the panel and subframe and to the top surface of the upper stop (-4).
- During final assembly, apply Loctite 243 to the mating threads of the coupler (-5) and the fixed plug (-3).
- When installed, the coupler is to be tightened to a torque of 20 Nm (15 lbf ft), applying the torque between the coupler (-5) and the fixed plug (-3) to avoid twisting the rods (-1 and -2). Do not over-tighten.
- After final torque, additional Molybdenum-based anti-seize compound should be placed around the thru hole in the coupler (-5) and on the outer threads of the fixed plug (-3) as a moisture barrier.
- For adequate wrench clearance, no structural member may be within 29.2mm (1.15 in) of the centerline of the axial rod at the ends of the coupling.

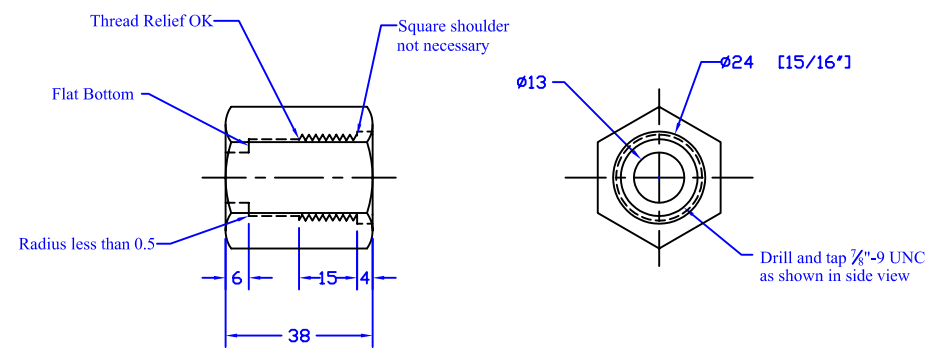
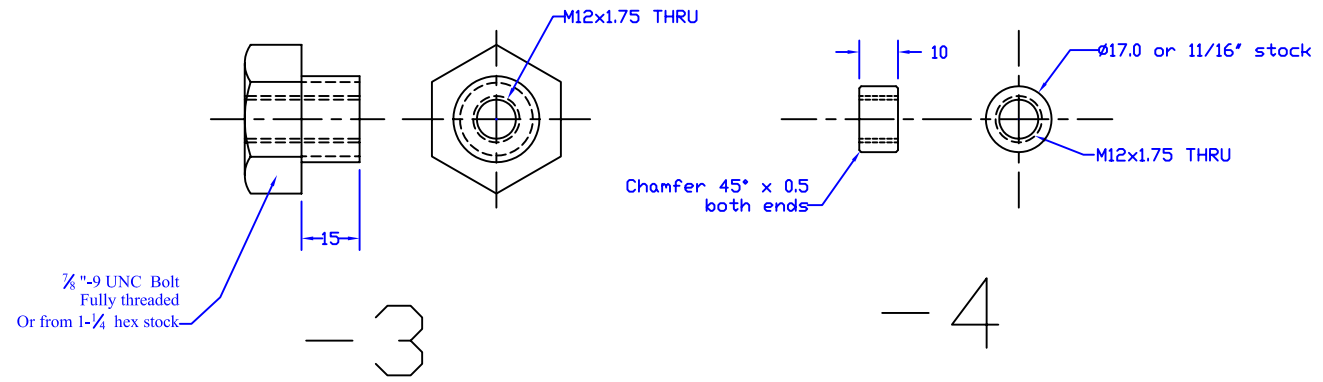

Notes:

- Material: 1-1/4" hex stock, 416 stainless
- Internal thread length of 15mm is minimum length of full depth threads

-5

BILL OF MATERIALS			
PART	DESCRIPTION	MATERIAL	QTY
Assy	Complete Assembly	Various	1440
-	M12 Nut	316 Stainless	@ 3
-	M12 Lock Washer	316 Stainless	@ 3
-	1/2" Spherical Washer Set	18-8 Stainless	@ 2
1	Upper Rod	316 Stainless, M12x1.75 threaded rod	@ 1
2	Lower Rod	316 Stainless, M12x1.75 threaded rod	@ 1
3	Fixed Plug	316 Stainless 7/8"-9 UNC bolt, or 1-1/4" hex stock	@ 1
4	Upper Stop	316 Stainless, 11/16" round stock	@ 1
5	Coupler	416 Stainless, 1-1/4" hex stock	@ 1

All dimensions in mm
Tolerances if not specified:
x. ±1
x.x ±0.25
x.xx ±0.025
Angles ±0.5 degree
Internal Corners Max Radius 0.5

MERLAB, P.C. 309 S. McDonough St.
Decatur, GA 30030

Axial Rod and Couplings

Dr. by: D.R. Smith
Ck by: DRS

SIZE	FSCM NO.	DWG NO.	REV
D		MRLB-LMT-1000	1

SCALE 1:1 Sep. 3, 2002 SHEET 1/1