

REPORT DOCUMENTATION PAGE

Form Approved
OMB NO. 0704-0188

Public Reporting burden for this collection of information is estimated to average 1 hour per response, including the time for reviewing instructions, searching existing data sources, gathering and maintaining the data needed, and completing and reviewing the collection of information. Send comment regarding this burden estimates or any other aspect of this collection of information, including suggestions for reducing this burden, to Washington Headquarters Services, Directorate for Information Operations and Reports, 1215 Jefferson Davis Highway, Suite 1204, Arlington, VA 22202-4302, and to the Office of Management and Budget, Paperwork Reduction Project (0704-0188,) Washington, DC 20503.

1. AGENCY USE ONLY (Leave Blank)		2. REPORT DATE Sept 23, 2005	3. REPORT TYPE AND DATES COVERED Final Report 01-July-98 - 31-oct-04	
4. TITLE AND SUBTITLE Collaborative Research: Multisensor Approach to Mapping of 2D and 3D Geologic Features from Remotely Sensed Imagery			5. FUNDING NUMBERS DAAG55-98-1-0287	
6. AUTHOR(S) Melba M. Crawford				
7. PERFORMING ORGANIZATION NAME(S) AND ADDRESS(ES) University of Texas, Center for Space Research 3925 W. Braker Lane Austin, TX 78759			8. PERFORMING ORGANIZATION REPORT NUMBER	
9. SPONSORING / MONITORING AGENCY NAME(S) AND ADDRESS(ES) U. S. Army Research Office P.O. Box 12211 Research Triangle Park, NC 27709-2211			10. SPONSORING / MONITORING AGENCY REPORT NUMBER 37571.1-EV	
11. SUPPLEMENTARY NOTES The views, opinions and/or findings contained in this report are those of the author(s) and should not be construed as an official Department of the Army position, policy or decision, unless so designated by other documentation.				
12 a. DISTRIBUTION / AVAILABILITY STATEMENT Approved for public release; distribution unlimited.			12 b. DISTRIBUTION CODE	
13. ABSTRACT (Maximum 200 words) <p>The goal of this research project was to develop, implement, and evaluate computational methods for extracting information from multiple sources of remotely sensed data for thematic and topographic mapping of geologic features. The research focused on three primary areas:</p> <ul style="list-style-type: none">• Integration of multisource topographic information in a multiresolution framework• Development of supervised classification methods for multispectral and hyperspectral data.• Extraction of topographic features from multiple return LIDAR data acquired from airborne platforms. <p>The project focused on the first two problems during the original three year study, which was augmented to conduct a two year intensive study of LIDAR and hyperspectral data for coastal mapping applications. Summary descriptions of the methodologies and example results are provided..</p>				
14. SUBJECT TERMS Digital elevation models, multiresolution methods, statistical classification, LIDAR			15. NUMBER OF PAGES 25	
			16. PRICE CODE	
17. SECURITY CLASSIFICATION OR REPORT UNCLASSIFIED	18. SECURITY CLASSIFICATION ON THIS PAGE UNCLASSIFIED	19. SECURITY CLASSIFICATION OF ABSTRACT UNCLASSIFIED	20. LIMITATION OF ABSTRACT UL	

Final Report

Project: DAAG55-98-1-0287

**Collaborative Research: Multisensor Approach to Mapping of 2D and 3D
Geologic Features from Remotely Sensed Imagery**

Principal Investigator:

M.M. Crawford, UT Center for Space Research,
Ph (512) 471-7993 Fax (512) 471-3570, Email: crawford@csr.utexas.edu
The University of Texas at Austin
3925 W. Braker Lane, Suite 200
Austin, TX 78759-5321

Co-Principal Investigators:

V.R. Baker

Ph: (520)621-7875 Fax: (520)621-1422, Email: baker@pir1.lpl.arizona.edu
Department of Hydrology and Water Resources
J.W.Harshbarger Building, Room 122
The University of Arizona
Tucson, Arizona 85721-0011

J. C. Gibeaut

Ph (512) 471-0344 Fax (512) 471-0140, Email: jim.gibeaut@beg.utexas.edu
Bureau of Economic Geology
P.O Box X
The University of Texas at Austin
Austin, TX 78713-8924

V. Baker

Department of Hydrology
The University of Arizona

Table of Contents

I. Introduction	1
II. Research Results	1
A. Multisensor Topographic Mapping	1
A.1 Dynamic Adaptive Grid Hierarchy	1
A.2. Multiscale Kalman Smoothing	4
B. Land Cover Mapping	7
B.1 Feature Selection	7
B.2 Feature Extraction	7
B.3 Bayesian Pairwise Classification	8
B.4 Binary Hierarchical Classification	10
C. High Resolution Mapping from LIDAR	12
III. Bibliography	18
IV. Project Publications	21
V. Participating Personnel	24

I. Introduction

High quality topographic models and maps of land cover are critical for a wide range of applications including strategic military operations, disaster response, and environmental monitoring. These requirements are evidenced by the NASA SRTM ICESat, and EO-1 missions, as well as advances in airborne synthetic aperture radar (SAR) interferometry, light detection and ranging (LIDAR), and improved multispectral and hyperspectral sensors. The goal of this research project was to develop, implement, and evaluate computational methods for extracting information from multiple sources of remotely sensed data for thematic and topographic mapping of geologic features. The research focused on three primary areas:

- Integration of multisource topographic information in a multiresolution framework
- Development of supervised classification methods for multispectral and hyperspectral data.
- Extraction of topographic features from multiple return LIDAR data acquired from airborne platforms.

The project focused on the first two problems during the original three year study, which was augmented to conduct a two year intensive study of LIDAR and hyperspectral data for coastal mapping applications. The following sections contain a review of the approaches investigated and major accomplishments for the individual project components.

II. Research Results

A. Multisensor topographic mapping

Topographic information is provided by optical and radar stereo, single and repeat pass interferometry, and laser altimetry. Stereo-based optical methods are suited to mapping high relief in cloud-free daylight environments. Topography derived from stereo radar can be acquired in a day-night, all weather environment, but has poorer vertical resolution than optical stereo. Interferometry-based methods are superior in low and medium relief areas, but repeat pass interferometry suffers from decorrelation due to surface changes between passes, requires precise information on the position of the sensor, and is affected by atmospheric anomalies. Airborne laser altimetry provides high resolution height information if the position of the aircraft is known accurately, but acquires data over narrow swaths that must later be mosaicked after removing nonstationary biases from the individual flightlines. New methods are needed to utilize information from DEM's acquired at multiple horizontal and vertical resolutions by all these methods. A capability to update topographic maps through time, maintaining the full integrity and resolution of the original data sets is also required.

A.1 Dynamic Adaptive Grid Hierarchy. During the first year of the study, a new interpolation method was developed to integrate topographic information of different resolutions acquired from multiple sensors into a seamless, variable resolution digital elevation model DEM, maintaining the highest resolution available for every point. The problem was formulated to maintain the integrity of the highest resolution DEM over an area

and seamlessly interpolate the DEM's at the boundaries using a variable grid data structure, the Dynamic Adaptive Grid Hierarchy (DAGH) [1,2]. DAGH was originally designed for solving partial differential equations (PDE) with the capability of adaptive mesh refinement. Whenever local errors from the integration of the PDE on the solution grid exceed the predetermined threshold, it adaptively refines the area and iterates to obtain the solution locally. The system maps N-dimensional subspaces of different resolution into a 1-dimensional space using space-filling curves that achieve locality preserving mappings. By maintaining records of the relative coordinates and the instantaneous resolution of subgrids, DAGH then allows manipulation of data across different levels while preserving resolution locally. The data structure was modified for multiresolution integration of remotely sensed data. This required "inverse" application of the DAGH in the sense that the locations of refinement are predetermined. Once a locality of multiple resolution data is defined, its structure is preserved for subsequent analysis. The variable resolution data sets are then represented with localized subgrids at different resolutions, and the Adaptive Mesh Refinement - Hierarchical Data Format (AMR-HDF) is utilized to store and retrieve a series of multi-dimensional, multiple-sized, locally variable resolution data in one file. The concept is illustrated in Figure 1.

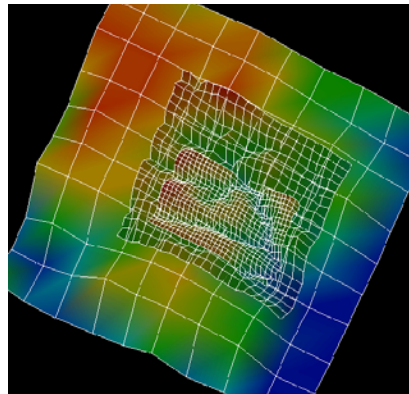

Figure 1. Variable resolution integration of multiple resolution information via DAGH

The methodology was implemented and evaluated using both simulation data and multiresolution data acquired over central Australia during a NASA JPL AIRSAR campaign in 1996. A regional 100m resolution DEM based on 1:100,000 maps, an ERS-1 based interferometric DEM, and 10m airborne TOPSAR data shown in Figure 2 with the resulting variable resolution DEM.

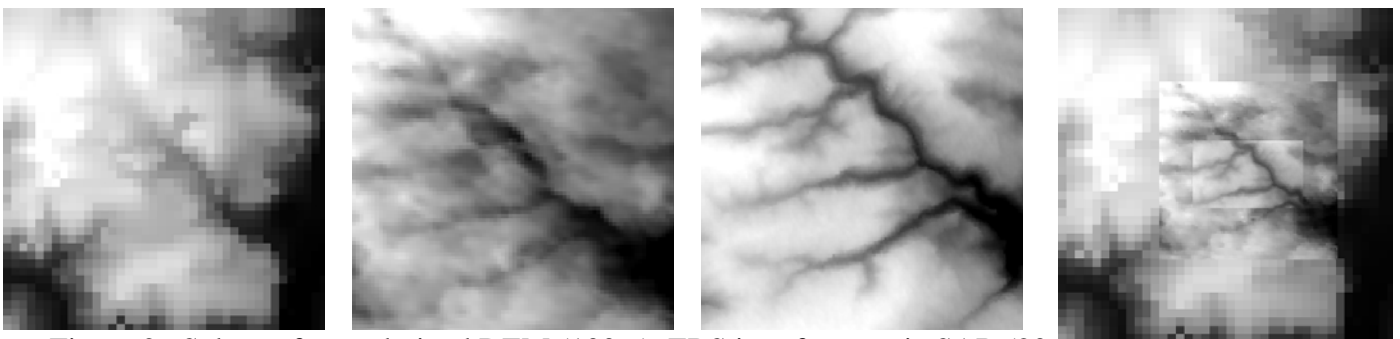

Figure 2. Subset of map-derived DEM (100m), ERS interferometric SAR (20m), and TOPSAR (10m) data with fused result.

There are several potential advantages of the DAGH approach for data fusion and/or variable resolution data representation: 1) multiple data sets are stored in a single file with appropriate indexing using AMR-HDF; 2) the DAGH allows potential reduction in storage when only the reliable segments of data are saved; 3) by preserving the local resolution, seamless retrieval of data is possible; and 4) the ability to track the evolution of local resolution enables the extraction of uni-grid (homogeneous resolution) DEM's as desired. The primary disadvantage of the approach related to computational requirements for the system and the requirement for post-processing before ingestion in geographic information system software packages. Some applications also require smoother transition across boundaries of data sets. An alternative integration approach was developed to handle these problems.

A.2. Multiscale Kalman Smoothing. During the second year of the study, the project focused on development of a multiscale interpolation system based on a quadtree framework. The approach involved extensions of a traditional time domain state space representation implemented as a multiscale model on a pyramid structure [5,6,7]. Because the models satisfy the Markov property in scale and space, efficient recursive estimation algorithms based on extensions of Kalman filtering and smoothing are employed. The covariance of the errors is also produced directly for a given model. Data are represented on a pyramid of multiple resolutions as shown in Figure 3.

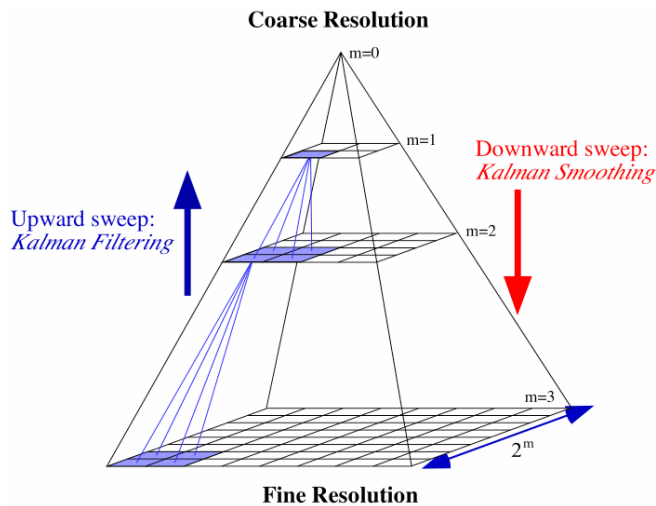

Figure 3. Data pyramid illustrating parent/child relationships of MKS system

Estimation proceeds iteratively. The system is initialized, then upward/downward sweeps are performed until the estimates converge. The primary challenges were identification of the state model, including the transition matrix to maintain the Markovian structure of the model and determination of appropriate measures of uncertainty for the model and measurement equations that reflect the nonstationarity of the spatial stochastic process. The methodology is fully described in [8,9].

The new methodology was evaluated using the multiresolution data acquired from central Australia, but included 3 new acquisitions of 5m TOPSAR data over the Fink Gorge National

Park shown in Figure 4. The common area in the TOPSAR acquisitions corresponding to the ERS subset shown on with their corresponding look angles. The topographic data from individual flightlines is shown in Figure 5 with the associated uncertainties. Differences in TOPSAR data are due to differing look angles, phase unwrapping problems, etc. The resulting fused data are shown in Figure 6 with corresponding estimates of local uncertainties and the overall mean uncertainties. Figure 7 shows a fused product over an extended region using ERS and TOPSAR data at 20, 10, and 5 meter resolution respectively.

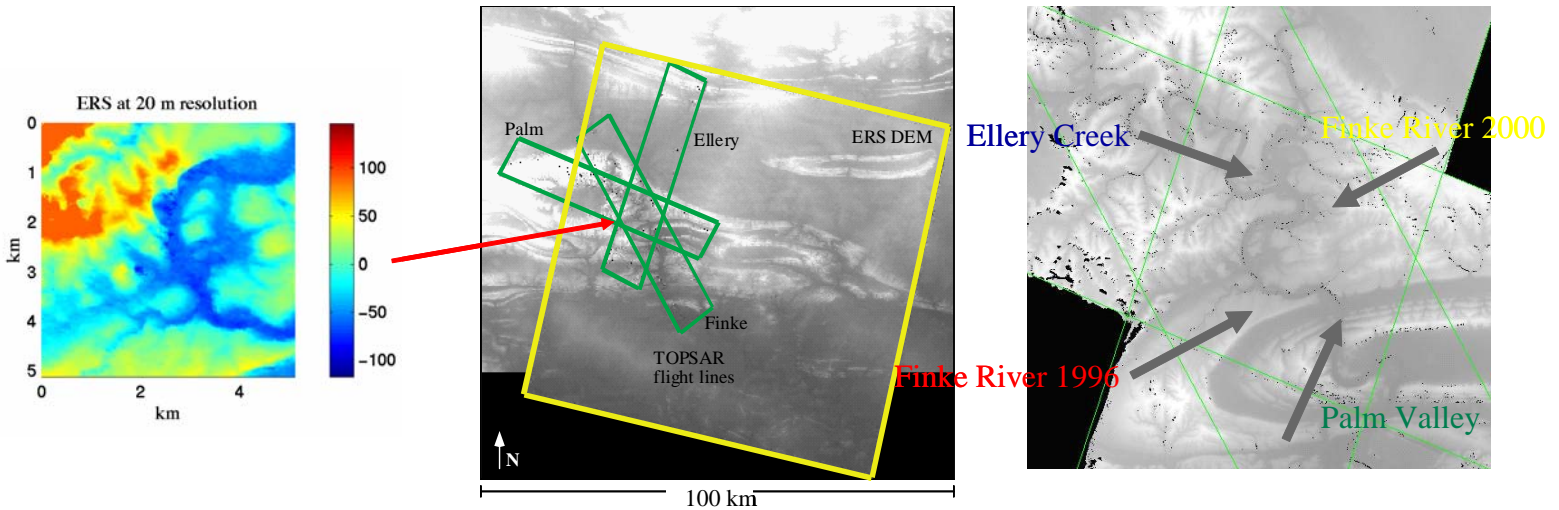

Figure 4. Multiscale regional topographic data over central Australia from 100m map based DEM, 20m ERS interferometry, and airborne TOPSAR. Look angles for 1996 and 2000 TOPSAR flightlines are indicated.

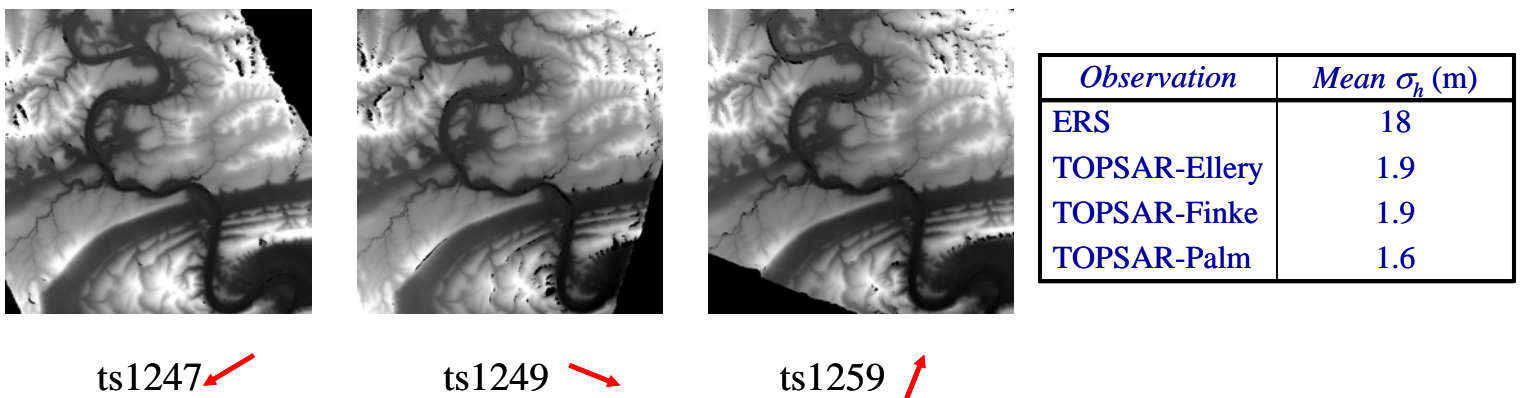

Figure 5. Subsets of 2000 TOPSAR data from various flightlines with associated uncertainty acquired over the Finke River Ellery Creek, and Palm Valley subset in 2000 (5 m) resolution.

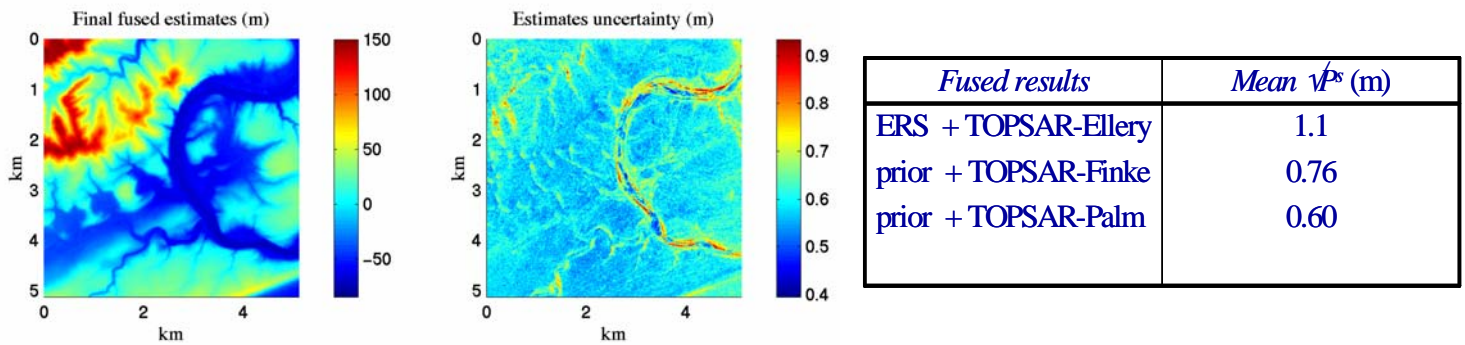

Figure 6. Fusion results and associated uncertainties from combining ERS and TOPSAR flightlines using MKS algorithm

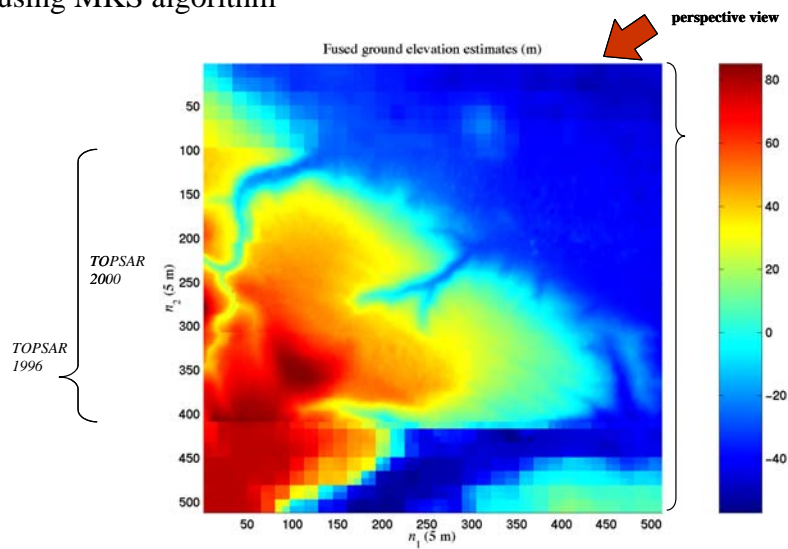

Figure 7. Fusion results for ERS (20m), 1996 TOPSAR (10m), and 2000 TOPSAR (5m) data.

The methodology was also used to fuse the 30m DEM product derived from SRTM and 5m LIDAR data acquired over Austin, Texas. Figure 8 indicates how the method successfully filled holes in the in the LIDAR DEM where vegetation and buildings had been removed, while sharpening the coarse resolution SRTM DEM.

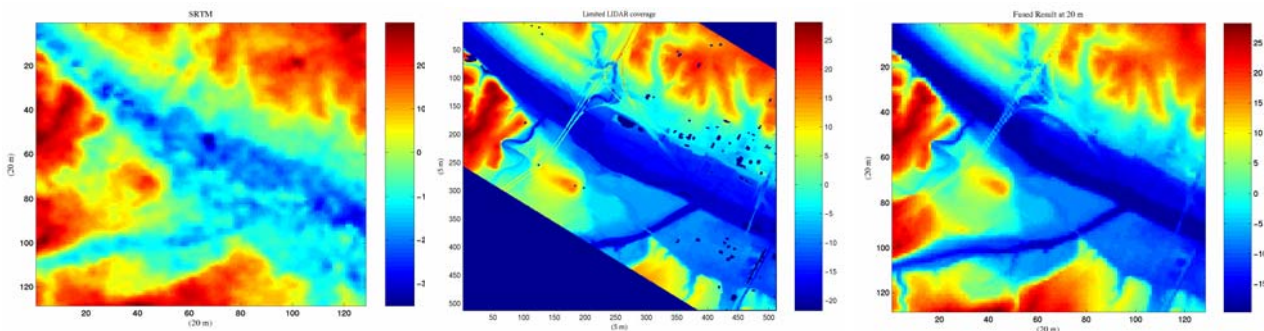

Figure 8. Subset of SRTM data over Austin, TX, bare earth topography derived from LIDAR, and fused result.

B. Land Cover Mapping from High Dimensional Data.

Hyperspectral instruments capable of acquiring data in hundreds of bands provide tremendous potential for discriminating between targets which are spectrally similar. Data from airborne systems were becoming more widely available, and both military and civilian hyperspectral missions were scheduled to fly during the period of the project. Standard supervised and unsupervised techniques are inadequate for exploiting these data. During the second year of the study, research was initiated on approaches for supervised analysis of hyperspectral data. The research focused on supervised classification of high dimensional input data for problems where outputs are also potentially high dimensional and the quantity of training data is limited. A multiclassifier framework, which provided the capability to tune a set of classifiers in binary frameworks, was adopted for the study. Two new methods, one involving a pairwise framework and the other utilizing a binary hierarchical approach, were developed. Within these frameworks, several methods for band selection and extraction were investigated.

B.1 Feature Selection

High dimensional data, which are typically highly correlated within class dependent band groups, are problematic for parametric classifiers if the quantity of training data is limited. This problem was addressed during the study via various methods for feature selection and extraction, which were also implemented in combination within the classifier system developed during the project.

Greedy forward selection was first investigated in conjunction with pairwise classification schemes. Here, class dependent features are selected based on their incremental contribution to a log-likelihood based relevance function that provides a measure of discrimination of each class pair [10]. Because of their capability to avoid local optima, heuristic search techniques were evaluated via an implementation of tabu search methodology [11]. During the last year of the study, random subspace methods were implemented in conjunction with bagging of training data to address the small sample problem.

B.2 Feature Extraction

Because it maximizes the distance between populations, the Fisher projection was employed as the primary feature extraction method for the binary classification frameworks. Unstable estimates of covariance matrices were avoided by utilizing the extractor in conjunction with other techniques which reduced the dimension of the input space during a pre-processing stage. A new best bases band combining technique which combines highly correlated adjacent bands for each class was developed to reduce the number of inputs, but retain interpretable inputs [12-15]. A polyline spectral approximation method was also developed, both to reduce the input dimension and provide a set of stable features that could be related biogeophysical parameters [16].

B.3 Bayesian Pairwise Classification

The BPC method developed in this study approaches the multi-class problem with $C (> 2)$

classes as a set of $\binom{C}{2}$ simpler two-class problems. For each pair (i, j) of classes

$(1 \leq i < j \leq C)$, a separate classifier is trained to distinguish only between those classes.

Results of the pairwise classifiers are obtained, and the ultimate class is then selected either via voting or by the maximum Bayesian posterior probability rule applied to an estimate of posterior probabilities obtained from the outputs of the individual pairwise classifiers. While the framework can accommodate a wide variety of classifiers, the approach was developed with the goal of successfully utilizing weak classifiers for each pair. The system, which is illustrated in Figure 9, was implemented in conjunction with a Gaussian model and has been used operationally for a wide range of applications using multispectral, hyperspectral, and radar remote sensing data [10, 12, 14]. One example is included for illustrative purposes.

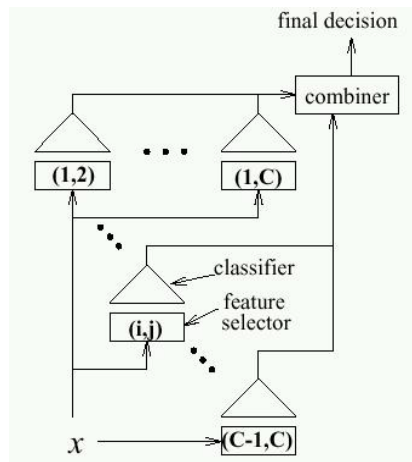

Figure 9. Bayesian pairwise classification framework

ALI data sets from 2001 (May 31, June 16, July 11, and August 19) and a single ETM+ scene (August 12, 2001) were first classified as members of the twenty-three land cover classes found in the seasonal and occasional swamps and drier woodlands. Training data were selected manually using a combination of GPS located vegetation surveys, aerial photography from the Aquarap (2000) project, and IKONOS multispectral imagery. Data sets were randomly sampled such that 50% were used for training, with 50% reserved for testing the classifier. In order to compensate for bias associated with co-location of training and test data within patches, additional sites were selected and used for an independent determination of accuracies. Figure 10 shows the resulting labeled image for the May 31 date, and Figure 10 contains classification results for the scene using both greedy feature selection and the Fisher extractor. Detailed discussion of results, including comparison with the standard maximum likelihood classifier, is presented in [15].

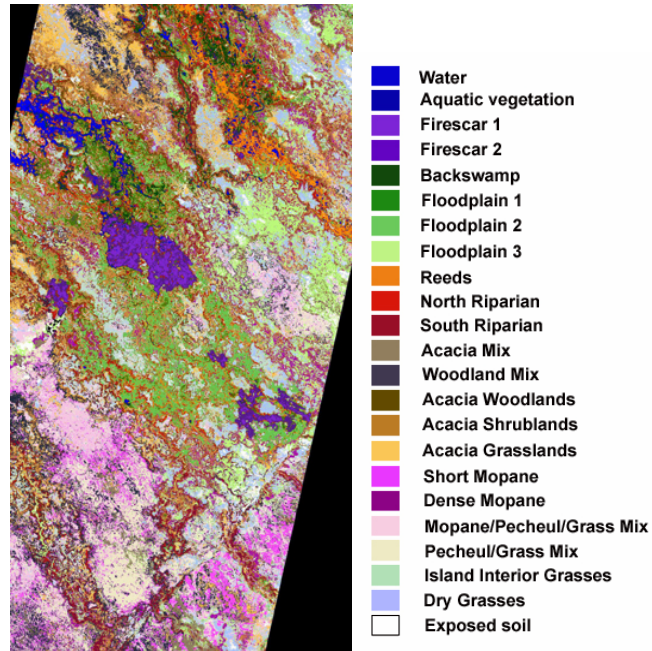

Figure 10. Labeled ALI data over the Okavango Delta, May 31, 2001

CLASS	BPC-FS		BPC-F1	
	Producers	Users	Producers	Users
north riparian	44.98	44.34	36.36	38.78
south riparian	68.39	53.44	64.25	59.62
short mopane	53.95	80	59.07	76.51
mopane (dense)	60	70.82	59.64	62.84
acacia mix	99.16	72.84	99.16	71.08
woodland mix	77.27	78.7	71.82	81.44
acacia woodlands	41.72	26.81	49.67	29.76
acacia shrublands	23.08	37.17	34.07	43.36
acacia grasslands	66.43	57.41	65.71	56.44
mopane/pechuel/grass	94.52	76.24	91.1	79.17
grass/pechuel mix	87.74	87.74	91.61	84.52
dry grasses	51.68	67.54	46.98	61.4
island interior	34.08	43.93	30.04	44.37
exposed soil	85.34	75.86	81.47	75.6
reeds1	75.76	83.89	79.39	80.86
backswamp	69.77	94.74	64.34	85.57
floodplain1	67.94	63.12	67.94	61.81
floodplain2	61.14	54.13	72.54	62.22
floodplain3	41.71	34.43	30.29	29.78
water	99.63	99.26	99.63	99.26
aquatic vegetation	93.23	99.44	95.83	98.92
firescar2	95.65	100	96.74	98.89
Overall	68.12		67.87	
kappa	.6659		.663	

Table 1. Classification accuracies for Okavango Delta Data using BPC with feature selection

B.4. Bayesian Hierarchical Classification

The Binary Hierarchical Classifier (BHC), which was originally developed external to this project, uses a Generalized Associative Modular Learning System (GAMLS) algorithm for determining the hierarchical tree structure [17,18]. A hierarchical tree structure is generated by dividing the C class problem into C-1 two class problems (referred as meta-classes), as illustrated in Figure 11.

In the original implementation, each meta-class contains its own unique feature space extracted using the Fisher(1) or Fisher(m) projection. The top down BHC is initiated such that the root node contains all classes. Classes are allocated to two internal child nodes using the GAMLS method [17]. The process is recursively repeated as each internal node is separated into two meta-classes until each class is fully separated as a leaf node. The TD-BHC was developed as a decomposition method for classification problems with complex, high dimensional output spaces. It is also advantageous in that it is computationally efficient and less greedy than common agglomerative schemes, including a bottom-up implementation of the method (BU-BHC).

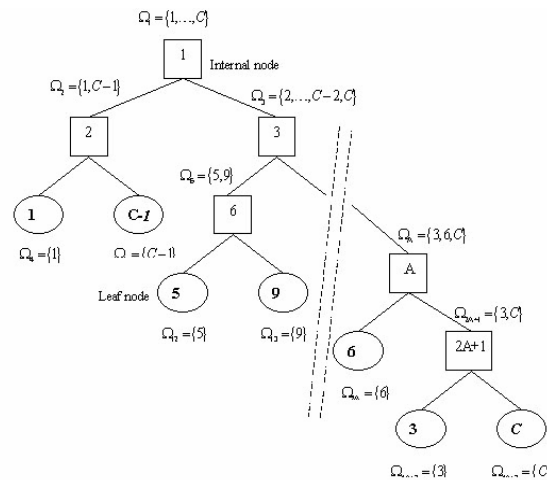

Figure 11. Bayesian Hierarchical Classification Framework

The BHC framework was the foundation of the research in hyperspectral methods during the last two years of the project. The small sample size problem is critical for virtually all hyperspectral problems studied. Sequential separation of the classes into natural meta-class groupings mitigated the impact of the small training data sets as the training data for the mixed classes was adequate for estimating parameters at higher levels of the tree. The best bases and polyline extractors were utilized only when the small sample sizes were encountered at lower levels of the tree and only for those classes which required reduction in the input dimension.

BHC has been utilized to classify both airborne and space-based multispectral and hyperspectral data. Classification results from corresponding hyperspectral scene acquired by the Hyperion, the hyperspectral instrument on the EO-1 satellite, on May 31, 2001, are shown in Figure 12, and corresponding accuracies for various implementations of the algorithm are shown in Figure 13. The classes have been modified somewhat to reflect the classes in the reduced area covered by Hyperion acquisition.

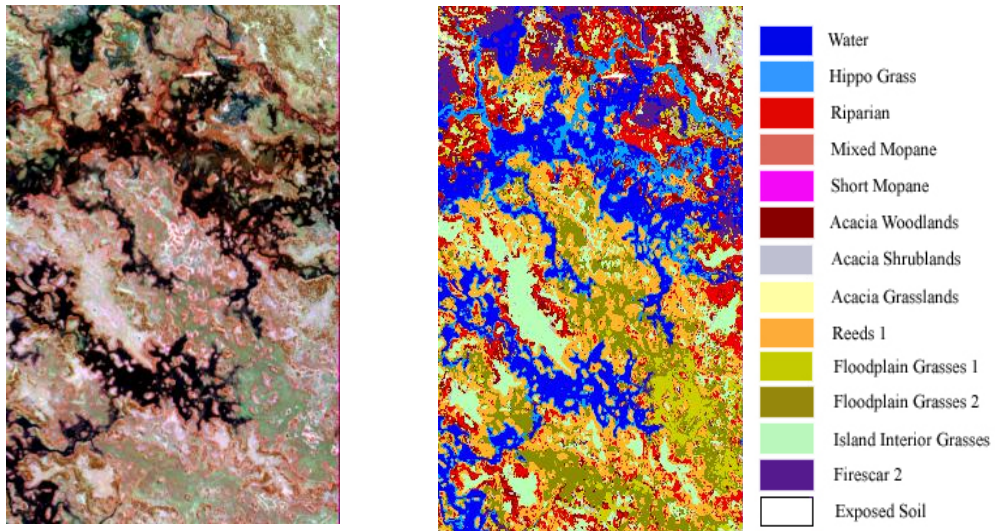

Figure 12. Subset of May 31, 2001 Hyperion data (bands 51, 149, 31) and the resulting classified image.

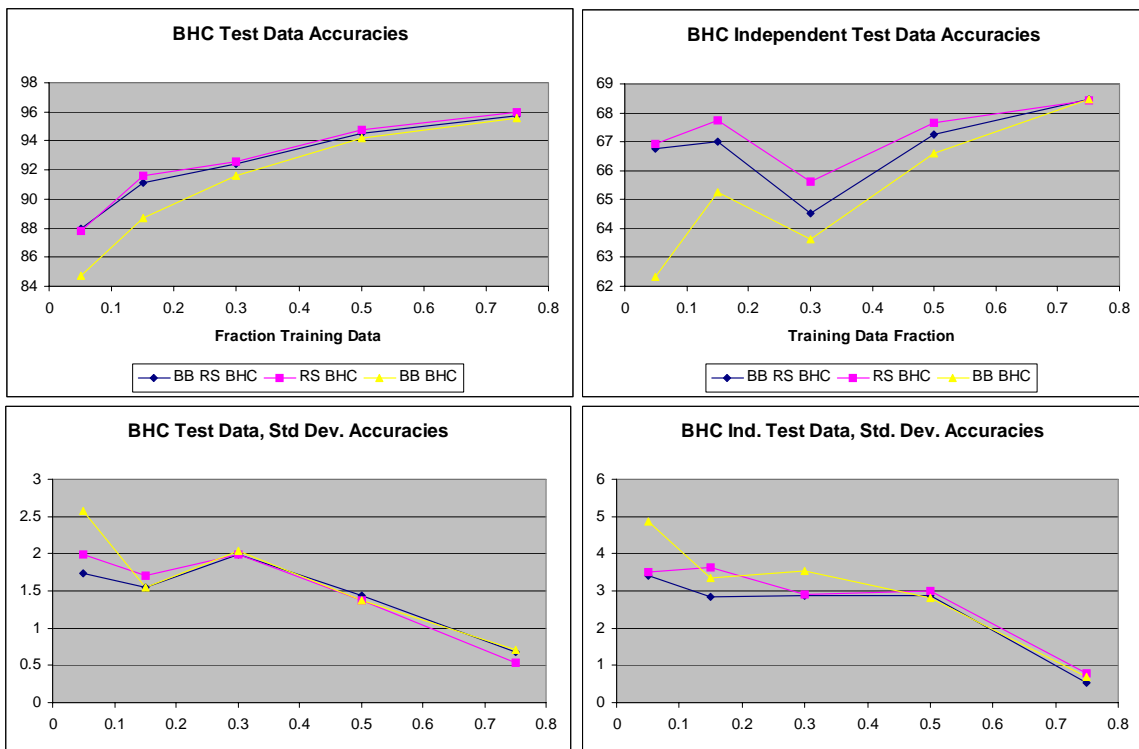

Figure 13. Sample mean and standard deviation of overall classification accuracies for BHC implementations.

C. High Resolution Mapping from Light Detection and Ranging (LIDAR) Data

High resolution topographic maps provide critical information for a wide range of scientific, public and commercial sector, and military applications. Capable of acquiring elevations with decimeter-level accuracy, LIDAR is quickly becoming the technology of choice for creating topographic maps over limited areas requiring high resolution information. Detailed, accurate topography is particularly critical in low gradient coastal environments which often undergo frequent change due to environmental and anthropogenic impacts. In the coastal zone, small changes in height relative to sea level can dramatically affect local geomorphology and vegetation cover, both of which are of interest to the military for landing in the beach zone and navigating coastal wetlands. An extension of the original project was funded by the Office of Naval Research and conducted as a collaborative project with the UT Bureau of Economic Geology. This study involved extension of an algorithm developed for extracting surface features from multiple return LIDAR and evaluation of its potential via a case study conducted over Matagorda Island, a sandy barrier island on the Texas coast. The science component of the study focused on obtaining high resolution topography to gain a better understanding of the dynamics of habitat distribution on low-lying barrier islands.

C.1 Feature extraction from airborne LIDAR.

The LIDAR processing algorithm, which adapts parameters to local terrain, involves a sequence of operations shown in Figure 14. Data points are first filtered to remove extreme long and short ranges that are typically associated with anomalies, and then gridded using the minimum value of the last return in each grid cell. Low frequency variation in the terrain represented by a local average surface is first subtracted from the pseudo ground surface, yielding high-pass zero-mean residual information. The ground values are detected in this “pseudo” ground surface through a novel application of the lower envelope follower (LEF) used to recover the message signal from an amplitude-modulated signal. (In general, a LEF tracks a modulated signal that decreases or slowly increases. However, if the modulated signal increases quickly, the LEF decays exponentially.) The concept was adapted to the problem of developing a 2-D lower envelope (surface) of the LIDAR data to identify candidate ground level values. The resulting lower envelope surface is used to threshold the high-pass residuals, creating a mask of the data points in the initial ground surface detected to be on the lower envelope of the signal. Together, these operations form the lower envelope detector. Unfortunately, many ground points are not detected in low relief regions as the LEF follows the lower envelope of the noise in these areas. To recover these points, the method grows the lower envelope detection surface with a gradient flood fill algorithm.

Bridges and large buildings with flat surfaces may not have been removed using these operations, so a gradient-based feature detector is applied for these man-made structures. A final ground surface of the entire region is created by interpolating values to fill gaps. This surface is then used to classify ground and non-ground points by thresholding the original LIDAR data values. Resulting non-ground points are separated into building and non-building points by detecting the points along the buildings’ roofs and edges using first and last return observations. Details are contained in [22]

Ground Detection

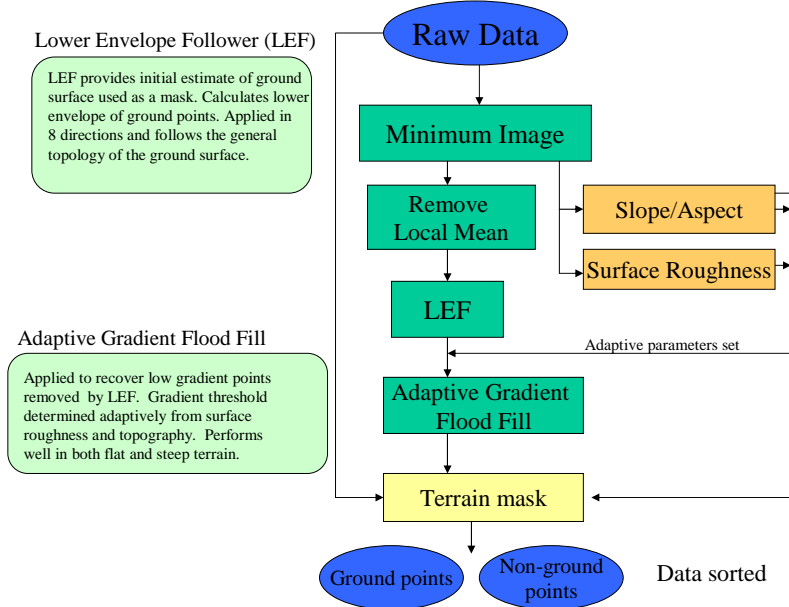

Figure 14. Flow diagram for extracting bare earth topography from LIDAR data

C.1. Matagorda Island case study.

The field area was 20 km² of the southwest end of Matagorda Island, an undeveloped barrier island on the central Texas coast (Figure 15). This area comprises an open-ocean sandy beach, multiple dune lines, ridge and swale topography, back barrier stabilized and active dune fields, relict recurved spits and tidal channels, and a large relict washover/flood tidal delta fan (Figure 16). The area is now part of the Matagorda National Wildlife Refuge, although it once served as an air force bombing range. No urban development has occurred on the island and the only development present now includes decommissioned runways, a few buildings, and ditches and dikes. A DEM of a section of the island (Figure 17) was derived and compared to a map of habitats manually developed from color infrared aerial photography and field visits (Figure 18).

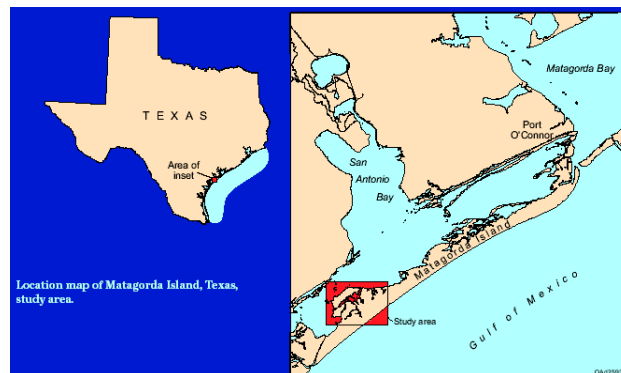

Figure 15. Location map, Matagorda Island, Texas



Figure 16. Aerial photograph of the study area looking northwesterly toward San Antonio Bay. The surf of the Gulf of Mexico is at the bottom.

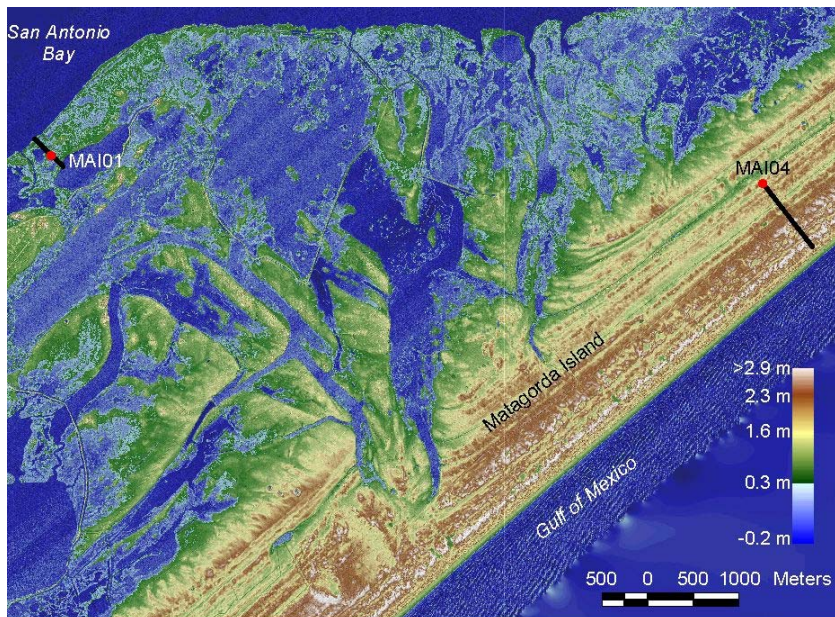

Figure 17. Shaded relief image of digital elevation model of the study area. Banding in open-water areas is oriented parallel to the acquisition flight lines and is the result of about 0.05 m vertical error across the data swaths. The banding is only apparent on the very smooth water surface.

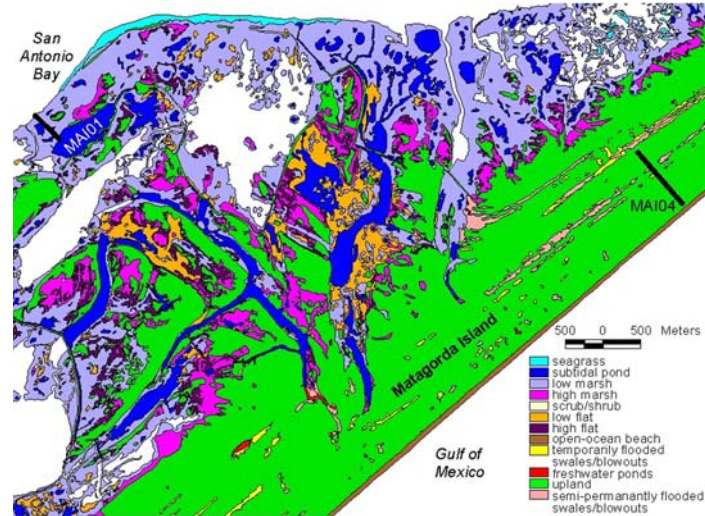

Figure 18. Habitat classification map developed by interpretation of color infrared photography and field visits.

Figure 19 is a plot of the mean elevations and standard deviations of the habitats mapped from the aerial photography. The units are arranged along the x -axis in the expected order of increasing elevation, and it is apparent that the DEM is in accordance with this. Average elevations of the intertidal and upland habitats have a total range of less than 2 m. Habitat elevations are separated in an expected vertical sequence, but standard deviations (Figure 17) show overlap between environments, indicating that elevation is not the only controlling factor on habitat type and that vegetation affects the LIDAR based elevations. The average elevation of low marsh areas was only 0.22 m above the water level of ponds interior to the relict flood-tidal delta in the study area. Sedimentation rates are expected to be very low in these areas with no open-water communication with the bay. Thus, a rise in relative sea level of just 0.22 m will expand the ponds and have a profound effect on the marshes. Based on sea-level rise in the bay since the 1950's, this amount of rise is expected to occur during the next 55 years. The LIDAR did not penetrate water; thus the sea-grass elevation is actually the surface of the bay water during the time of the survey. The same is true for the subtidal ponds, which are interior to the washover fan/flood tidal delta complex and have no channels for communication with the bay, and the freshwater ponds and flooded swales and blowouts interior to the upland area. There is also a lack of data in places with a smooth water surface due to specular reflection away from the aircraft. At least some of the overlap and high standard deviations are caused by vegetation such as the upland scrub/shrub unit. Greater relief caused by ridges and swales, dunes, and blowouts, however, is probably mostly responsible for the higher standard deviations in the upland units. Mean elevations gradually increase from sea grass to high marsh and from flooded swales and blowouts to upland, but an abrupt change of 0.49 m occurs between these intertidal and supratidal environments.

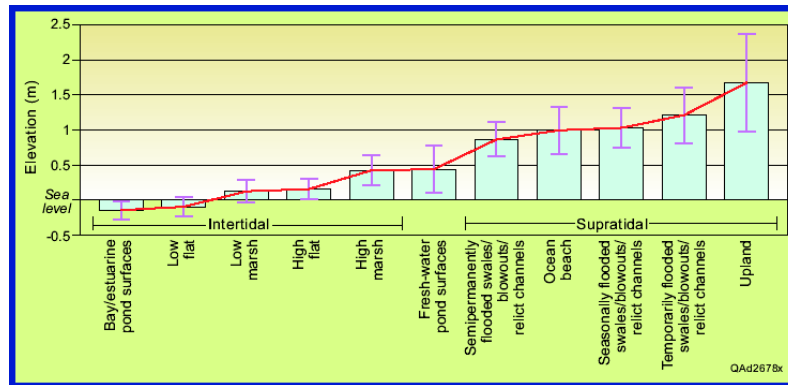

Figure 19. Average heights and standard deviations above mean sea level for barrier island habitats.

Figure 20 contains a plot of the MAI01 ground transect (see Figure 17 for location). The ground elevation, vegetation height, and LIDAR data points that are within 1 m horizontal distance of the transect line are shown. Vertically, the LIDAR data points fall within the vegetation cover and 0.1 to 0.2 m above the ground elevation in low marsh areas and 0.2 to 0.6 m above ground in the upland area. The vertical scatter caused by the vegetation cover in the low-marsh area masks morphology with relief of less than 0.2 m occurring across horizontal scales of 10 m or less.

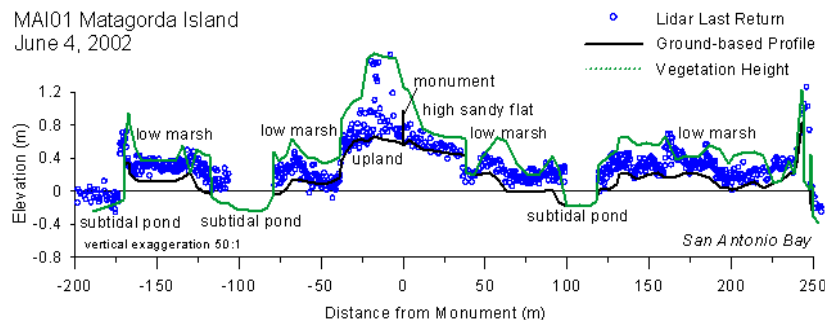

Fig. 20. Ground surveyed substrate and vegetation height relative to mean sea level. Lidar data points within a horizontal distance of 1 m from the transect are also plotted.

Delineation of the boundaries between low and high marshes and between tidally influenced and upland environments is a very difficult, but important determination. Analysis of the LIDAR based DEM shows that the derived topography is accurate and detailed enough to serve as an independent and physically meaningful layer in analysis involving other remote sensing data such as multispectral or hyperspectral imagery. Vegetation causes biases and scatter in the LIDAR point data resulting in standard deviations that overlap between environments. However, vegetation is not the only contributing factor to overlapping elevations. Proximity to and amount of communication with bay waters may also control the development of low or high marsh, flats or uplands.

Reducing the scattering and bias effects of the vegetation on the LIDAR points would make the LIDAR more useful in barrier island settings. As noted previously, the instrument used for this survey recorded two ranges for each outgoing laser pulse. The resolution of these measurements, however, does not allow distinguishing ranges that are within several meters of each other. This is useful in a tall tree canopy, but not for low vegetation typical of the study area. Future advances with full waveform digitization or low photon return systems may provide additional capability for resolving these problems.

III. Bibliography

1. M. Parashar and J.C. Browne [1995], "Distributed dynamic data-structures for parallel adaptive mesh-refinement," *Proc. Intl. Conf. on High Performance Computing*, 22-27.
2. S. Mitra, M. Parashar, M., and J.C. Browne [1997] *DAGH: User's Guide*, Department of Computer science Report, The University of Texas at Austin, August, 1997.
3. V. Chewings [1997], personal communication, CSIRO Division of Wildlife and Ecology, Centre for Arid Zone Research, Australia.
4. O. Kwon, O., M.M. Crawford, and V.R. Baker [1998], "Variable resolution INSAR topographic mapping of ancient fluvial landscapes in Australia," *Proc. 1998 International Geoscience and Remote Sensing Symposium*, Seattle, July 6-10, 1998, 2363-2366.
5. K.C. Chou, A.S. Willksy, and A. Benveniste [1994], "Multiscale recursive estimation, data fusion, and regularizaton," *IEEE Trans. Automat. Contr.*, **39**(3):464-478.
6. M.M. Daniel and A. S. Willsky [1997], "A multiresolution methodology for signal-level fusion and data assimilation with applications to remote sensing," *Proc. of the IEEE*, vol. 85(1):164-180.
7. P. Fieguth, W.C. Karl, A. Willsky, and C. Wunsch [1995], "Multiresolution optimal interpolation and statistical analysis of TOPEX/POSEIDON satellite data," *IEEE Trans. Geosci. Remote Sens.*, **GRS 33**(2): 280-292.
8. K.C. Slatton, M.M. Crawford, and B.L. Evans [2000], "Combining interferometric radar and laser altimeter data to improve estimates of topography," *Proc. 2000 International Geoscience and Remote Sensing Symposium*, Honolulu, Hawaii, July 24-28, 960-964.
9. K.C. Slatton, M.M. Crawford, and B.L. Evans [2001], "Fusing interferometric radar and laser altimeter data to estimate surface topography and vegetation heights," *IEEE Trans. on Geoscience and Remote Sensing*, **GRS 39**(11): 2470-2482.
10. M.M. Crawford, S.Kumar, S., M.R. Ricard, J.C., Gibeaut, and A. Neuenschwander [1999], "Fusion of airborne polarimetric and interfermetric SAR data for classification of coastal environments," *IEEE Trans. Geosci. Remote Sens.*, **GRS 37**(3):1306-1315.
11. D. Korycinski, *Investigating the Use of Tabu Search to find Near-Optimal Solutions in Multiclassifier Systems*, PhD. Dissertation, The University of Texas at Austin, 2003.
12. S. Kumar, J. Ghosh, and M.M. Crawford [2000a], "Multiresolution feature extraction for pairwise classification of multispectral data," presented at the SPIE Meeting, San Diego, January 2000.
13. S. Kumar, J. Ghosh, and M.M. Crawford [2000b], "Classification of hyperspectral data using best- bases feature extraction algorithms," presented at the SPIE Meeting, Orlando, Ca, April 2000.
14. S. Kumar, J. Ghosh, and M.M. Crawford [2001], "Best basis feature extraction algorithms for classification of hyperspectral data," *IEEE Trans. Geosci. Rem. Sens.* **29**(7): 1368-79.

15. A. Neuenschwander [2003], "Characterization of the vegetation of the Okavango Delta, Botswana using EO-1 data," Masters Thesis, Department of Aerospace Engineering, University of Texas at Austin, 2003.
16. J.T. Morgan, A. Henneguella, M.M. Crawford, J. Ghosh, and A. Neuenschwander, [2002] "Adaptive feature spaces for land cover classification with limited ground truth," in *Proc. Third Intl. Workshop, MCS 2002*, F. Roli and J. Kittler, Eds. Germany: Springer-Verlag Lecture Notes in Computer Science, #2364: 189-200.
17. A. Henneguella, J. Ghosh, and M.M. Crawford [2003] "Polyline feature extraction for land cover classification using hyperspectral data," *Proc. ICAI-2003*, Hyderabad, India, Dec. 18-20, (publication in progress via CD).
18. S. Kumar, J. Ghosh, and M.M. Crawford [2000] "A hierarchical multiclassifier system for hyperspectral data analysis," *Lecture Notes in Computer Science*, Ed. F. Roli and J. Kittler, **1857**:270-279.
19. S. Kumar, J. Ghosh, and M.M. Crawford [2002], "Hierarchical fusion of multiple classifiers for hyperspectral data analysis," *Int. J. Pattern Analysis and Applications*, **5**(2): 210-220.
20. P. Gamba and B. Houshmand [2000], "Digital surface models and building extraction: a comparison of IFSAR and LIDAR data," *IEEE Trans. Geosci. Rem. Sens*, **38**(4),
21. H. Maas and G. Vosselman [1999], "Two algorithms for extracting building models from raw laser altimetry data," *ISPRS Journal of Photogrammetry & Remote Sensing*, **54**:153-163.
22. C. Weed, C. [2001], "Classification of LIDAR data using a lower envelope detector and gradient based methods" (M.S. Thesis), Dept. of Operations Research and Industrial Engineering, The University of Texas at Austin.
23. C.A. Weed, M.M. Crawford, A.L. Neuenschwander, and R. Gutierrez [2002], "Classification of LIDAR data using a lower envelope follower and gradient-based operator," *Proc. 2002 International Geoscience and Remote Sensing Symposium*, Toronto, Canada, June 24-28, 1384-1386, extended version submitted to *Photogrammetric Engineering and Remote Sensing*.
24. Gibeaut, J. C. [2003], "Lidar: mapping a shoreline by laser light" *Geotimes*, **48**(11), p. 23-27, 2003.
25. Gibeaut, J. C. and Smyth, R. C. [2003], "LIDAR surveys for coastal hazards and resource mapping," workshop presented at Coastal Zone 2003, Baltimore Maryland, July 14, 2003.
26. Gibeaut, J. C., White, W. A., Smyth, R. C., Andrews, J. R., Tremblay, T. A., Gutiérrez, Roberto, Hepner, T. L., and Neuenschwander, Amy [2003], "Topographic variation of barrier island subenvironments and associated habitats," in *Coastal Sediments '03: Crossing disciplinary boundaries: Proc., Fifth International Symposium on Coastal Engineering and Science of Coastal Sediment Processes*, Clearwater Beach, Florida, May 18-23, 10 p., CD-ROM.
27. Gibeaut, J. C., White, W. A., Gutierrez, R., Waldinger, R., and Andrews, J. R. [2003], "The Texas shoreline change project: combining lidar, historical photography, and ground surveys to measure shoreline change rates along bay and Gulf of Mexico shorelines," in *Coastal Geotools '03: Proc. of the 3rd Biennial Coastal GeoTools Conference*, Charleston, South Carolina, January 6-9, abstract, CD-ROM, 2003.

28. Gibeaut, J. C., White, W. A., Smyth, R. C., Andrews, J. R., Tremblay, T. A., and Hepner, T. L. [2004], "Topographic variation of barrier island wetlands: implications for modeling change during rising relative sea level," *Proc. Texas Coastal Issues Conference*, March 10-12, Corpus Christi, Texas, in press.

Publications Supported Under Grant DAAG55-98-1-0287

Archival Journal Articles

M.M. Crawford, S.Kumar, S., M.R. Ricard, J.C., Gibeaut, and A. Neuenschwander [1999], "Fusion of Airborne Polarimetric and Interferometric SAR Data for Classification of Coastal Environments," *IEEE Trans. Geosci. Remote Sens.*, **GRS 37**(3):1306-1315, 1999.

J.T. Morgan, A. Henneguella, M.M. Crawford, J. Ghosh, and A. Neuenschwander, [2002] "Adaptive Feature Spaces for Land Cover Classification with Limited Ground Truth," in *Proc. Third Intl. Workshop, MCS 2002*, F. Roli and J. Kittler, Eds. Germany: Springer-Verlag Lecture Notes in Computer Science, #2364: 189-200.

J. Ham, Y. Chen, M. Crawford, and J. Ghosh [2005], "Investigation of the Random Forest Framework for Classification of Hyperspectral Data," *IEEE Trans. on Geoscience and Remote Sensing*, **43**(3), 492-501.

S. Kumar, J. Ghosh, and M.M. Crawford [2000] "A Hierarchical Multiclassifier System for Hyperspectral Data Analysis," *Lecture Notes in Computer Science*, Ed. F. Roli and J. Kittler, **1857**:270-279.

K.C. Slatton, M.M. Crawford, and B.L. Evans [2001], "Fusing Interferometric Radar and Laser Altimeter Data to Estimate Surface Topography and Vegetation Heights," *IEEE Trans. on Geoscience and Remote Sensing*, **GRS 39**(11): 2470-2482.

S. Kumar, J. Ghosh, and M.M. Crawford [2002], "Hierarchical Fusion of Multiple Classifiers for Hyperspectral Data Analysis," *Int. J. Pattern Analysis and Applications*, **5**(2): 210-220.

Gibeaut, J. C. [2003], "Lidar: Mapping a Shoreline by Laser Light" *Geotimes*, **48**(11), p. 23-27, 2003.

J.T. Morgan, J. Ham, M.M. Crawford, A. Henneguella, and J. Ghosh [2004], "Adaptive Feature Spaces for Land Cover Classification with Limited Ground Truth Data," (substantively different from *Lecture Notes in Computer Science* version), *Int. J. Pattern Recognition and Artificial Intelligence*, **18**(5), 777-799.

J. Ham, Y. Chen, M. Crawford, and J. Ghosh [2005], "Investigation of the Random Forest Framework for Classification of Hyperspectral Data," *IEEE Trans. on Geoscience and Remote Sensing*, **43**(3), 492-501.

Conference Proceedings

O. Kwon, O., M.M. Crawford, and V.R. Baker [1998], "Variable Resolution INSAR Topographic Mapping of Ancient Fluvial Landscapes in Australia," *Proc. 1998 International Geoscience and Remote Sensing Symposium*, Seattle, July 6-10, 1998, 2363-2366.

K.C. Slatton, M.M. Crawford, and B.L. Evans [2000], "Combining Interferometric Radar and Laser Altimeter Data to Improve Estimates of Topography," *Proc. 2000 International Geoscience and Remote Sensing Symposium*, Honolulu, Hawaii, July 24-28, 960-964.

S. Kumar, J. Ghosh, and M.M. Crawford [2000], "Classification of Hyperspectral Data Using Best-Bases Feature Extraction Algorithms," *Proc. SPIE*, Orlando, Ca, April 2000.

S. Kumar, J. Ghosh, and M.M. Crawford [2000], "Multiresolution Feature Extraction for Pairwise Classification of Multispectral Data," *Proc. SPIE*, San Diego, January 2000.

C.A. Weed, M.M. Crawford, A.L. Neuenschwander, and R. Gutierrez [2002], "Classification of LIDAR Data Using a Lower Envelope Follower and Gradient-based Operator," *Proc. 2002 International Geoscience and Remote Sensing Symposium*, Toronto, Canada, June 24-28, 1384-1386, extended version submitted to *Photogrammetric Engineering and Remote Sensing*.

Gibeaut, J. C., White, W. A., Smyth, R. C., Andrews, J. R., Tremblay, T. A., Gutiérrez, Roberto, Hepner, T. L., and Neuenschwander, Amy [2003], "Topographic Variation of Barrier Island Subenvironments and Associated Habitats," in *Coastal Sediments '03: Crossing disciplinary boundaries: Proc., Fifth International Symposium on Coastal Engineering and Science of Coastal Sediment Processes*, Clearwater Beach, Florida, May 18-23, 10 p., CD-ROM.

Gibeaut, J. C., White, W. A., Gutierrez, R., Waldinger, R., and Andrews, J. R. [2003], "The Texas Shoreline Change Project: Combining Lidar, Historical Photography, and Ground Surveys to Measure Shoreline Change Rates Along Bay and Gulf of Mexico Shorelines," in *Coastal Geotools '03: Proc. of the 3rd Biennial Coastal GeoTools Conference*, Charleston, South Carolina, January 6-9, abstract, CD-ROM.

Gibeaut, J. C., White, W. A., Smyth, R. C., Andrews, J. R., Tremblay, T. A., and Hepner, T. L. [2004], "Topographic Variation of Barrier Island Wetlands: Implications for Modeling Change During Rising Relative Sea Level," *Proc. Texas Coastal Issues Conference*, March 10-12, Corpus Christi, Texas.

Y. Chen, M.M. Crawford, and J. Ghosh [2004], "Integrating Support Vector Machines in a Hierarchical Output Decomposition Framework," *Proc. 2004 International Geoscience and Remote Sensing Symposium*, Anchorage, Alaska, Sept. 20-24, 949-952.

Y. Chen, M.M. Crawford, and J. Ghosh [2005], “Applying Nonlinear Manifold Learning on Hyperspectral Data,” *Proc. 2005 International Geoscience and Remote Sensing Symposium*, Seoul, Korea, July 25-29, 4311-4314.

Other Presentations

Gibeaut, J. C. and Smyth, R. C. [2003], “LIDAR Surveys for Coastal Hazards and Resource Mapping,” workshop presented at Coastal Zone 2003, Baltimore Maryland, July 14.

Publications in Review

C.A. Weed, M.M. Crawford, A.L. Neuenschwander, and R. Gutierrez [2005], “Classification of High Resolution Lidar Data using a Lower Envelope Follower and Gradient-Based Operations,” submitted to *Photogrammetric Engineering and Remote Sensing*.

Participating Personnel

M. Crawford, Principal Investigator, University of Texas

V. Baker, Co-Principal Investigator, University of Arizona

J.C. Gibeaut, Research Scientist, University of Texas

Students

K.C. Slatton, Ph.D., Department of Electrical and Computer Engineering, 2002

C. Weed, M.S. Department of Mechanical Engineering, 2002

A. Neuenschwander, M.S. Department of Aerospace Engineering, 2003

O.I. Kwon, Ph.D. Department of Aerospace Engineering, in progress

Y. Chen, Ph.D., Operations Research and Industrial Engineering, in progress

J. Ham, Operations Research and Industrial Engineering, in progress