

TECHNICAL REPORT
NATICK/TR-06/006



AD _____

A NEW ARCHITECTURE FOR DIGITAL PACKET VIDEO SYSTEMS THAT ARE POWER- AND BANDWIDTH-EFFICIENT

by
**Steve Berman
Paul Greier
Kenneth Ho
Richard Kaufman
Michael Mastro
Steve Millman
Ron Ridgeway
Kai Schleupen
and
Steven Wright**

**International Business Machines Corporation
T.J. Watson Research Center
Yorktown Heights, NY 10598**

December 2005

Final Report
September 2002 – November 2004

Approved for public release; distribution is unlimited

Prepared for
**U.S. Army Research, Development and Engineering Command
Natick Soldier Center
Natick, Massachusetts 01760-5056**

DISCLAIMERS

The findings contained in this report are not to be construed as an official Department of the Army position unless so designated by other authorized documents.

Citation of trade names in this report does not constitute an official endorsement or approval of the use of such items.

DESTRUCTION NOTICE

For Classified Documents:

Follow the procedures in DoD 5200.22-M, Industrial Security Manual, Section II-19 or DoD 5200.1-R, Information Security Program Regulation, Chapter IX.

For Unclassified/Limited Distribution Documents:

Destroy by any method that prevents disclosure of contents or reconstruction of the document.

REPORT DOCUMENTATION PAGE

*Form Approved
OMB No. 0704-0188*

The public reporting burden for this collection of information is estimated to average 1 hour per response, including the time for reviewing instructions, searching existing data sources, gathering and maintaining the data needed, and completing and reviewing the collection of information. Send comments regarding this burden estimate or any other aspect of this collection of information, including suggestions for reducing the burden, to Department of Defense, Washington Headquarters Services, Directorate for Information Operations and Reports (0704-0188), 1215 Jefferson Davis Highway, Suite 1204, Arlington, VA 22202-4302. Respondents should be aware that notwithstanding any other provision of law, no person shall be subject to any penalty for failing to comply with a collection of information if it does not display a currently valid OMB control number.

PLEASE DO NOT RETURN YOUR FORM TO THE ABOVE ADDRESS.

1. REPORT DATE (DD-MM-YYYY) 12/06/2005		2. REPORT TYPE Final Report		3. DATES COVERED (From - To) September 2002-November 2004	
4. TITLE AND SUBTITLE A NEW ARCHITECTURE FOR DIGITAL PACKET VIDEO SYSTEMS THAT ARE POWER- AND BANDWIDTH-EFFICIENT.				5a. CONTRACT NUMBER DAAD19-02-2-0023	
				5b. GRANT NUMBER	
				5c. PROGRAM ELEMENT NUMBER	
6. AUTHOR(S) Steve Berman, Paul Greier, Kenneth Ho, Richard Kaufman, Michael Mastro, Steve Millman, Ron Ridgeway, Kai Schleupen and Steven Wright				5d. PROJECT NUMBER	
				5e. TASK NUMBER	
				5f. WORK UNIT NUMBER	
7. PERFORMING ORGANIZATION NAME(S) AND ADDRESS(ES) International Business Machines Corporation Research Division, T.J. Watson Research Center 1101 Kitchawan Road Yorktown Heights, NY 10598				8. PERFORMING ORGANIZATION REPORT NUMBER	
9. SPONSORING/MONITORING AGENCY NAME(S) AND ADDRESS(ES) Sponsor: Army Research Laboratory (ARL) 2800 Powder Mill Rd. Adelphi, MD 20783-1197				10. SPONSOR/MONITOR'S ACRONYM(S)	
				11. SPONSOR/MONITOR'S REPORT NUMBER(S) NATICK/TR-06/	
12. DISTRIBUTION/AVAILABILITY STATEMENT Approved for public release; distribution is unlimited.					
13. SUPPLEMENTARY NOTES Program Manager: Henry Girolamo, AMSRD-NSC-TP-S, 1 Kansas St., U.S. Army Soldier Systems Center, Natick, MA 01760					
14. ABSTRACT Three unique reconfigurable modules have been designed, assembled and tested with newly developed embedded logic: Input/Output Module (IOM), Image Processing Module (IPM) and Network Interface Module (NIM). These modules represent the core of a scalable network attached high-resolution video system that can scale up transmitting video information up to 4x HDTV resolution. The reconfigurability is based on the latest Xilinx Virtex-II Pro chips with dual embedded PowerPCs. All video data within the system is digital and packetized. System control data including remote PTZ camera control is transmitted within the same network transmission channel. Due to its reconfigurability, the system will vary the Region of Interest parameter and also the compression algorithm.					
15. SUBJECT TERMS PACKET VIDEO RECONFIGURABLE UNMANNED VEHICLES DIGITAL PACKET VIDEO LINK MODULAR NETWORKS SURVEILLANCE NEXT GENERATION DISMOUNTED SOLDIER BANDWIDTH VIDEO SIGNALS IMAGE PROCESSING VIDEO TELECONFERENCING DIGITAL VIDEO FLEXIBLE DISPLAYS REGION OF INTEREST COMPUTER ARCHITECTURE					
16. SECURITY CLASSIFICATION OF:			17. LIMITATION OF ABSTRACT SAR	18. NUMBER OF PAGES 38	19a. NAME OF RESPONSIBLE PERSON Henry Girolamo, Program Manager
a. REPORT U	b. ABSTRACT U	c. THIS PAGE U			19b. TELEPHONE NUMBER (Include area code) 508-233-5483

Table of Contents

List of Figures	iv
Preface	v
Summary	1
1. Introduction	3
2. Architectural Design of the Scalable “BlueEagle” Platform	4
2.1 System architecture in managable functional modules	4
2.2 Choice of prefered compression algorithm	4
2.3 Scalability	5
3. “BlueEagle” Hardware Module Design	6
3.1 Input/Output Module (IOM)	6
3.1.1 Input/Output Module (IOM) Design	6
3.1.2 Input/Output Module (IOM) Specificatons	8
3.1.3 Input/Output Module (IOM) Packaging	9
3.2 Image Processing Module (IPM)	10
3.2.1 Image Processing Module (IPM) Design	10
3.2.2 Image Processing Module (IPM) Specifications	11
3.2.3 Image Processing Module (IPM) Packaging	12
3.3 Network Interface Module (NIM)	13
3.3.1 Network Interface Module (NIM) Design	13
3.3.2 Network Interface Module (NIM) Specifications	14
3.3.3 Network Interface Module (NIM) Packaging	15
3.4 Overall Packaging of “BlueEagle” System	16
3.5 Cameras and Pan&Tilt&Zoom (PTZ) Units used with “BlueEagle” System	17
3.5.1 Ikegami HDL-40 camera with Fujinon Motorized Lens and Pan&Tilt System	17
3.5.2 Silicon Image Camera with ESI Pan&Tilt and Computar motorized lens	17
3.5.3 ISG camera	19
3.6 BlueEagle System in a Surveillance Application with IBM’s Peoplevision Software	20
4. Software for the “BlueEagle” System	21
4.1 Graphical User Interface (GUI)	21
4.2 Screen Layout	21
5. Utilities Developed in Support of “BlueEagle” System	23
5.1 Utility Software for Control of Silicon Imaging single CMOS Sensor HD Camera	23
5.2 Video Server to Capture Uncompressed Video Data in Real Time	25
5.3 Digital Packet Video Link Protocol	25
6. Delivery of Two “BlueEagle” Systems	27
7. Conclusions	29
8. Distribution List	30

List of Figures

Figure 1: "Blue Eagle" system in 1920x1080 resolution setup.....	4
Figure 2: First Implementation of the compression on the encoder side in the IPM.....	5
Figure 3: Scaled-up "BlueEagle" system to 4x HDTV resolution.....	5
Figure 4: Input/Output Module (IOM) functional block diagram.....	6
Figure 5: Photograph of the fully populated Input/Output Module (IOM) after PCB assembly	7
Figure 6: Summary table of specifications of the Input/Output Module (IOM).....	8
Figure 7: Front view of IOM 19"-rackmountable 1U module with digital video capture interfaces.....	9
Figure 8: Back view of IOM 19"-rackmountable 1U module (J5 through J8 on the left side are additional high speed channels).....	9
Figure 9: Image Processing Module (IPM) functional block diagram.....	10
Figure 10: Photograph of the fully populated Image Processing Module (IPM).....	11
Figure 11: Summary table of the specifications of the Image Processing Module (IPM).....	11
Figure 12: Front view of IPM 19"-rackmountable 1U module with the eight auxiliary high speed interfaces and status LEDs in the front	12
Figure 13: Back view of IPM 19"-rackmountable 1U module from where the connections to the IOM and NIM are made as well the compact flash for the FPGA configurations is being inserted	12
Figure 14: Network Interface Module (NIM) functional block diagram	13
Figure 15: Fully populated Network Interface Module (NIM) after PCB assembly	14
Figure 16: Summary table of specifications of the Network Interface Module (NIM)	14
Figure 17: Front view of NIM 19"-rackmountable 1U module with smart card reader	15
Figure 18: Back view of NIM 19"-rackmountable 1U module with dual DVI outputs and Ethernet RJ45 connector.....	15
Figure 19: Fully packaged "BlueEagle" transmitter system unit.....	16
Figure 20: Fully packaged "BlueEagle" receiver system unit using identical hardware modules as in the transmitter system unit but programmed differently to accommodate functionality	16
Figure 21: Ikegami HDL-40 camera with Funjinon motorized HD lens and Funjinon Pan&Tilt system ..	17
Figure 22: SI-1920HD-RGB Camera Mounted on Computar H10Z1118MSP Motorized 2/3" Lens.....	18
Figure 23: ESI DPT-115 Pan/Tilt w/ Computar H10Z1118MSP Lens w/ SI-1920HD-RGB Camera.....	18
Figure 24: Interconnections between scaled-up "BlueEagle" system to accommodate for example transmission of digital signals of 4x HDTV resolution (3840x2160).....	19
Figure 25: "BlueEagle" system block diagram with IBM PeopleVision surveillance software.....	20
Figure 26: The WindowBE user interface	22
Figure 27: Screen capture of the Utility Program Manually controlling the CameraLink Cameras.....	24
Figure 28: Packet definition of the basic packet under DPVL protocol.....	25
Figure 29: Video data and packet timing format in the DPVL protocol.....	26
Figure 30: Example how "BlueEagle" IOM and NIM are being used for DPVL prototyping.....	26
Figure 31: Photo of the "BlueEagle" prototype system setup on the optical bench at ARL	27
Figure 32: Photo of the "BlueEagle" prototype system setup on the optical bench at ARL	28
Figure 33: Photo of the T221 screen showing on the left the 1920x1200 received image on the receiving side of the system and on the right the 1920x1080 image captured from camera converted to DVI format.....	28

Preface

This report describes an effort at IBM Research developing a new architecture for digital packet video systems that are both power-and bandwidth-efficient in support of visualization applications in the US Army, including systems applicable to flexible displays for the soldiers in the field. Potential candidates for high-resolution visualization applications are for example video conferencing, surveillance and unmanned vehicles which all have to work within given bandwidth constraints that can vary with time. The hardware development for this reconfigurable and scalable prototype platform, called BlueEagle, was completed during the period from September 2002 to November 2004, contract number DAAD19-02-2-0023, under the direction of the US Army Soldier Systems Center in Natick, MA and the US Army Research Laboratory in Adelphi, MD.

After the contract ended on November 30, 2004, IBM Research continued writing embedded code for this reconfigurable platform with a commitment to deliver two demo systems to the US Army. The first system was delivered on June 7 and 8, 2005, to the ARL site in Adelphi, MD. The second system was delivered on July 11, 2005, to the NSC site in Natick, MA. Between the installations, firmware and software updates occurred to keep both systems on the same level. There will be further updates to the system until the end of 2005.

A NEW ARCHITECTURE FOR DIGITAL PACKET VIDEO SYSTEMS THAT ARE POWER- AND BANDWIDTH-EFFICIENT

SUMMARY

The focus of this effort has been to build a modular, scalable and reconfigurable platform to test new architectures for digital packet video systems with an emphasis on bandwidth conservation along with low power consumption. In many real environments the bandwidth is dictated by the network's abilities and it cannot change without huge investments in upgrading the infrastructure. Efficient and effective utilization of available bandwidth and power is one of the biggest obstacles for getting meaningful visual information into the user's hands in order to make timely and correct decisions on high-information content imagery. The project was nicknamed "BlueEagle" since one of the applications is ultra-high-resolution video surveillance.

An early decision was made to make the "BlueEagle" system modular. This was done both to keep the task of designing this hardware a manageable effort and to allow flexibility for interconnection of "BlueEagle" system components. Furthermore, each of the modules can serve other purposes.

The scalability of the "BlueEagle" system derives from its modularity and is essential for the handling of ultra-high-resolution video content. Each module of the "BlueEagle" system is designed to handle at least 1920x1080 pixels at 30Hz frame video rate progressively. Connecting multiple modules together allows scalability to 3840x2160 pixels at 60Hz video frame rate and beyond.

The third main characteristic of our "BlueEagle" system is reconfigurability. This allowed us to design the overall system intelligently, using the same physical modules on both sides of the network and thus reducing the number of different module designs from six down to three. Nevertheless, the complexity of each module resembles that of a PC motherboard. Completing these complex designs with a small group of people at IBM Research was a challenging task because many different technical disciplines were required. Examples include knowledge of compression algorithms, multi-type memory controllers, video interfaces, networking and cutting-edge reconfigurable chips (FPGAs) with embedded PowerPCs. We used the latest FPGAs available which are best suited for video processing, even though these chips were available only as engineering samples throughout the first half of the project. The complexity of these leading-edge FPGAs paid off in the design as we were able to design each module of the "BlueEagle" project with a single FPGA in 1152-pin or 1536-pin BGA package.

The "BlueEagle" System consists of three different modules: the Input/Output Module (IOM), the Image Processing Module (IPM) and the Network Interface Module (NIM). Communication between the modules is established by high speed differential serial link provided by the Rocket-IO connections of the FPGAs, utilizing the Aurora protocol provided by Xilinx. Infiniband protocol is also possible (in case connection to other equipment is needed) because we chose Infiniband connectors and impedances to establish the physical connection between the modules.

The Input/Output Module (IOM) is used in two places: as input interface module to the camera system and as output interface module to a high-resolution visual system. The camera system consists of a CMOS or CCD block camera with pan&tilt unit and motorized lens. It was requested that the "BlueEagle" system be able to connect to different video camera interface types. Therefore we allow video inputs from HD-SDI (SMPTE 292M Standard), DVI-D (DVI 1.0 Standard) and CameraLinkTM (Camera Link Specifications V1.1). A video data rate up to 3.96Gbit/sec can be ingested into each input module of the "BlueEagle" system. The high-resolution visual system consists of a DVI-enabled monitor, keyboard, mouse and overlaying GUI from a supporting workstation. In addition to the interface adapter functions, the IOM's purposes are packetization/depacketization of the image data into background and regions of interest (ROIs) as well as background filtering.

The Image Processing Module (IPM) is responsible for encoding the packetized image data on the transmitting side and on the receiving side to decode the data stream. In the first few months in 2003 we chose JPEG2000 as our preferred compression. As compared to alternative choices for this application, the JPEG2000 algorithm is superior and more scalable with increased image size. Compared to baseline JPEG, JPEG2000 improves the compression efficiency, allows lossy and lossless compression, allows the presentation of multiple resolutions, allows tiling, allows region of interest coding, allows bit depth higher than 8bit and good error resilience. The design of the of the IPM was the most complex module in terms of printed circuit board routing because we decided to use the largest FPGA available, together with DDR memory and QDR memory. The FPGA is paired with a TI DSP to allow some diversion of FPGA functionality to the DSP, and to free up resources in the FPGA. This module has a very high serial IO bandwidth with 16 links, each with a maximum data rate of 3.125Gbit/sec (on production grade FPGAs).

The Network Interface Module (NIM) provides connection to 10/100/1000 Mbit-Ethernet networks, two DVI outputs, two Fibrechannel ports for potential storage, full data rate capable IEEE1394, serial PC interfaces and a smartcard interface for authentication implementations. This module has a large amount of DDR memory for multi-frame storage, allowing compensation for variations in network data rates.

Through November 2004 of this project, the three modules (IOM, IPM and NIM) were designed, fabricated in small quantities, and successfully tested separately for their functionality before developing embedded code for the overall platform. A “Roving Eye” application was developed and demonstrated to show the capabilities of the system.

IBM developed software for an overlaying GUI (1920x1200 pixels), designed to give the user overall control of the system by implementing a 1920x120 pixels toolbar. The toolbar can be controlled preferably by a trackball or by a mouse and it allows full control of the remote camera system, control of size of the region of interest and also control of spatial and temporal parameters of the background. In addition, the software can establish a link to the PeopleVision Software from IBM Research which enables automatic tracking of persons and specially-defined objects. When linked to the PeopleVision Software, the GUI software receives the region(s) of interest and allows the “BlueEagle” system to apply more bandwidth to that area.

Development of the embedded code is complex, and we have continued our development beyond November 30, 2004. We delivered two “BlueEagle” systems for demo purposes to the Army Research Laboratory and Natick Soldier Center in July 2005. Thereafter, the system could be scaled up to 4x HDTV resolution (3840x2160 pixels) or modules of the system can be used for other purposes. Examples are:

IOM: Generic digital video capture module for HD-SDI, CameraLink and DVI

IPM: Hardware implementation of any compression algorithm in real-time

NIM: Network attached desktop implementation (no harddrive, no OS) in secure environments,
DPVL multi-monitor adapter platform for command&control environment

The goal of this project is to use “BlueEagle” modules as a prototype platform for different visual applications, including high-speed wireless links. From this work we wish to derive a potential ASIC chipset solution, which would reduce component cost and also dramatically reduce packaging size. Digital high-resolution video surveillance is on the rise because of availability of new HD CMOS sensors at lower prices. It is expected that within the next 5 years, commercial video surveillance will be predominated by digital technology at HD level resolution. Therefore, video surveillance in the defense sector will be going beyond HD resolutions, such as 4k or 8k horizontal resolution. In the entertainment side of the high-end commercial sector, the Digital Cinema Initiative (DCI) December 2004 preliminary specifications embrace JPEG2000 as their compression algorithm because of its bit depth beyond 8bit and frame-by-frame handling for studio editors. Taken together, these developments boost the likelihood of a highly-integrated “BlueEagle” solution, compromising all the capabilities into a single chip.

1. Introduction

Transmission of high-resolution video images over communication channels requires a large amount of channel bandwidth. The large bandwidth requirements are a result of high data rates required to communicate high-resolution video data, particularly as the video image information content is increased from 640x480 (NTSC) to 1920x1080 (HDTV) and beyond, needed for many applications. Digital video cameras today can capture images more than four times larger than HDTV. The large bandwidth requirement is imperative unless techniques such as compression are applied to the video data. The problem of communicating video data signals is further compounded in situations where available channel bandwidths differ at various stages in the capture, transmission and reconstruction of the video data, or where available channel bandwidth may be changing over time. For portable imaging applications, power consumption is a major issue. Power consumption in video imaging systems depends primarily on the amount of processed video pixel data, and applies to all portions of the imaging chain: capture, compression, transmission, and reconstruction. Hence, reducing the bandwidth and power remains an important objective in video communications.

A common approach to reducing bandwidth requirements in video transmission is to use image compression. Compression techniques typically compress entire images, with compression ratios and resulting image quality chosen for a given application and nature of image content. Compression methods can be adapted to respond to changes in image aspects but they cannot be considered intelligent processing of the video image in comparison to the visual system of a human observer.

In the human visual system, a large number of photoreceptors are concentrated in the foveal region of the eye. As the eyes dart between various regions of interest in the image, only a small region of the image, near the fixation point, is processed by the human visual system to contain high-resolution image information. Compression techniques process the entire image even if only small regions of interest need to contain high-resolution visual data. In some systems, an attempt is made to enhance the image content by creating a magnified portion of the image within the overall field of view. However, the magnified region necessarily blocks adjacent, un-magnified background regions. For surveillance applications, use of a magnified region reduces situational awareness, and for other imaging applications, use of a magnified region reduces navigation ability.

Efforts have been made to create foveated displays and supporting systems to reduce data rates. These systems display higher image information content within a region of interest, the location of which is set by an eye-tracking device, worn by the user. Typically, a filter is applied to the video data to define the region of interest, in which image quality falls off gradually for pixel data farther from the center of the region of interest.

Overall, efforts to create foveated displays have remained unsatisfactory for many applications. If the distance between the image capture device and display is large enough to cause a signal delay more than a few milliseconds, the utility of a system containing an eye-tracking device is very limited. Eye-tracking devices tend to be cumbersome, expensive, and require calibration for good performance. Conventional foveated video imaging systems do not provide real-time controls to allocate available bandwidth to various portions of the video image data, or adapt to changes in the available bandwidth. These systems do not provide independent control of the resolution of portions of the video data, namely spatial sampling, temporal sampling, compression, and color bit-depth. Finally, none of these systems contain provisions for buffering the video data, with partial-frame packetization, encoding, or encryption of digital video data, suitable for either wireless transmission or transmission over a network. For surveillance applications, it is important to have a seamless image presentation of multiple regions of interest, with user or other software control for monitoring and tracking targets.

Hence, there is a need for a video communication system that requires relatively low bandwidth and power, through selective allocation of available system bandwidth to regions of interest within the video data. Such a system would need to be able to provide independent control of the resolution of portions of the video data, namely spatial sampling, temporal sampling, compression, and color bit-depth.

2. Architectural Design of the Scalable “BlueEagle” Platform

2.1 System architecture in manageable functional modules

Right from the beginning of this project it was decided to build the system modular in order to use the limited resources more efficiently. **Figure 1** shows the “BlueEagle” system in 1920x1080 mode setup as it was delivered to two sites for the US Army. The boxes in color represent the different “BlueEagle” system modules. The same color means that physically, the hardware is identical but contains different firmware for the specific functionality.

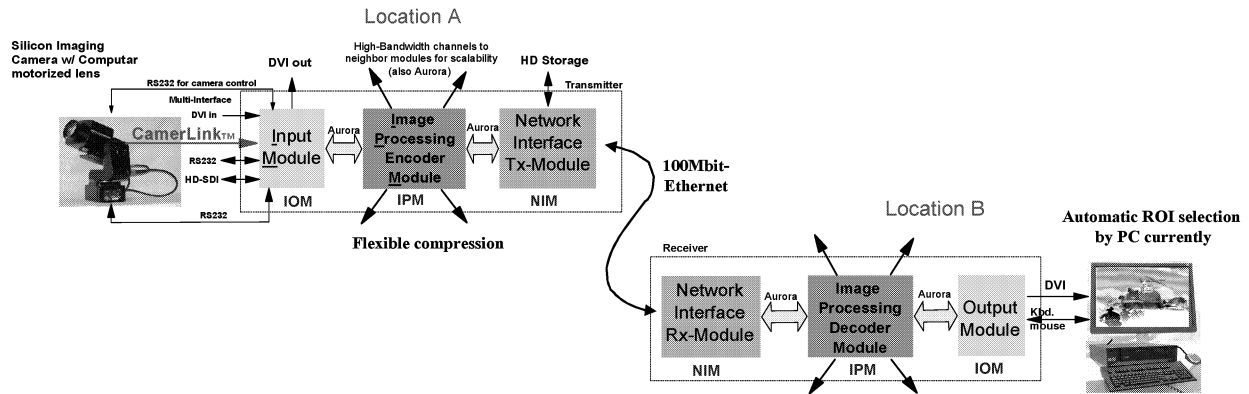

Figure 1: “BlueEagle” system in 1920x1080 resolution setup

The communication between the modules is running on the physical Rocket-IO layer of the Xilinx FPGA chips using the Aurora protocol. The interface between the modules carries video packet as well as control packets. The control packets are necessary for system control and peripheral control.

2.2 Choice of preferred compression algorithm

Essentially the system is a reconfigurable system and therefore any kind of compression algorithm can be implemented unless it exhausts the resources of the hardware. We decided during the course of the contract to choose JPEG2000 as our choice of compression because it is a wavelet-based algorithm which allows defining regions of interest. Furthermore, JPEG2000 allows for lossy and lossless modes. JPEG2000 is a very complex compression algorithm and we limited ourselves to compress only the region of interest after the packetizer. The background information is low bandwidth anyway and gets a different treatment.

Figure 2 shows the first implementation of the encoder which fits into the IPM and is still being debugged.

We have also plans to prototype different and new algorithms for JPEG on the “Blue Eagle” hardware and maybe if resources allow it move the compression into the IOM if we populate it with a bigger FPGA.

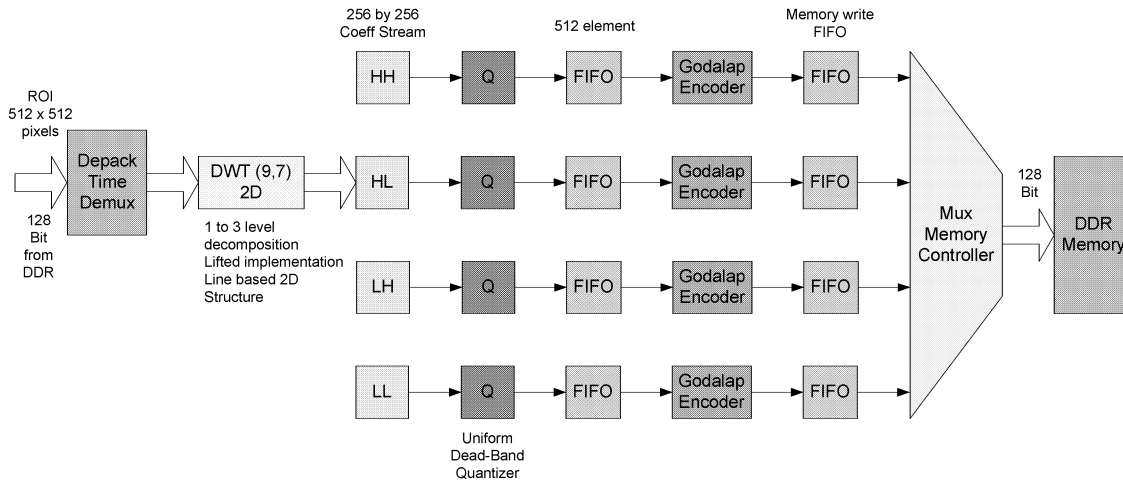

Figure 2: First implementation of the compression on the encoder side in the IPM

2.3 Scalability

Figure 3 Work is ongoing in the implementation of the functionalities for each of the six modules (Input IOM, Encoding IPM, Transmitter NIM, Receiver NIM, Decoding IPM and Output IOM) that will be used for the single channel demonstration system. It was decided to postpone integration of the Camera-Link interfaced camera until after the upcoming demo to allow focus on background image filtering, compression and overall system functionality.

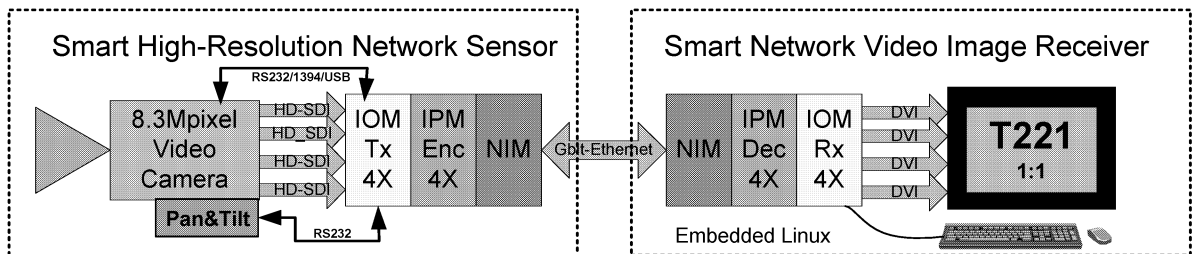

Figure 3: Scaled-up "BlueEagle" system to 4x HDTV resolution

3. “BlueEagle” Hardware Module Design

3.1 Input/Output Module (IOM)

As a module on the transmitting side of the “BlueEagle” system, the IOM needs to be able to connect to different camera interfaces (HD-SDI, DVI and CameraLink™) and to accomplish the preprocessing of the video data (filtering and packetization).

As a module on the receiving side of the “BlueEagle” system, the IOM needs to do video post-processing (de-packetize the video data, merge the right packets and do the inverse filtering) and output the video data via DVI channel on a monitor or projector.

As indicated in Section 2, this was achieved by designing a module which can accomplish both functions by different firmware on the FPGA but identical hardware.

3.1.1 Input/Output Module (IOM) Design

Figure 4 shows the block diagram of the IOM with all its peripheral interfaces which are accessible from the outside. On the left is the data input for the various video camera interfaces. On the right side the outputs for HD-SDI monitoring, DVI monitor output and Aurora channels on Infiniband 1x connectors to the next module, the IPM. The additional Aurora channels on the top are for the optional scalability of the system to expand resolution beyond 1920x1080 resolutions. On the bottom of **Figure 4** are all the generic interfaces of which some are use differently whether the module is used on the transmitting or receiving side of the “BlueEagle” system (see **Figure 5**).

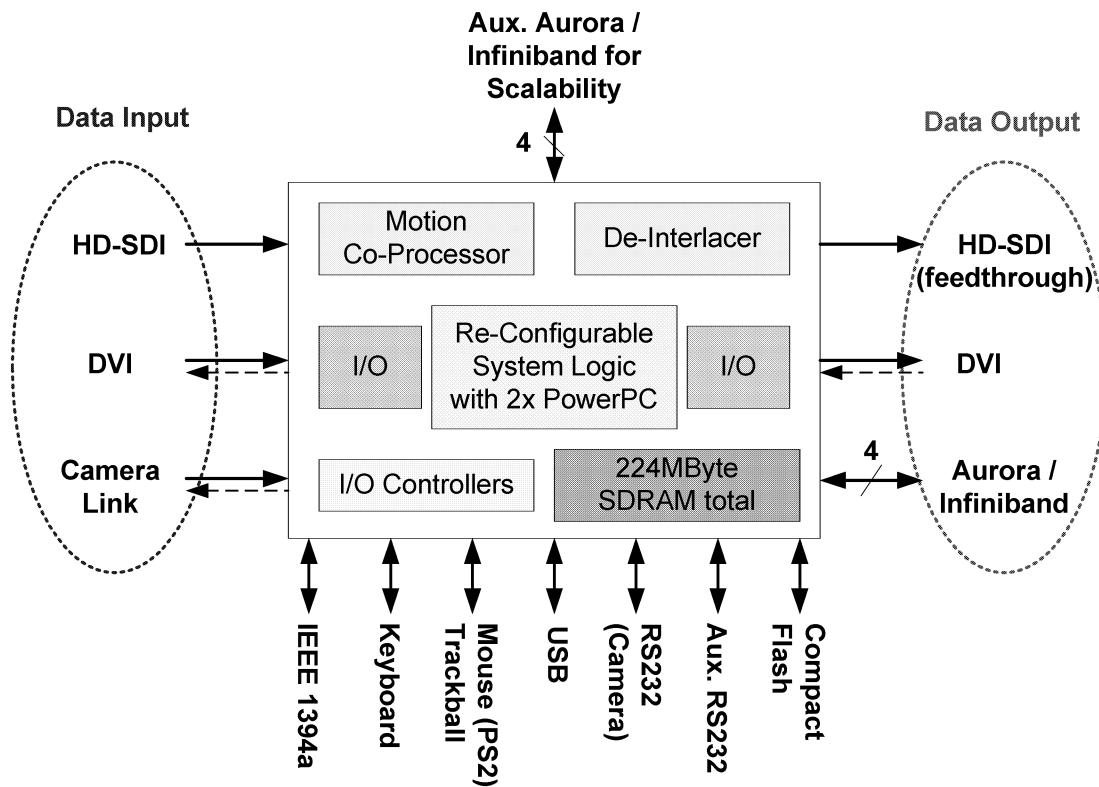

Figure 4: Input/Output Module (IOM) functional block diagram

In case of a HD-SDI camera with an interlaced 1920x1080 videostream we implemented Gennum chipset consisting of a motion Co-Processor and a de-interlacer chip which proved to give us professional quality progressive output as input to the FPGA. The FPGA, a Xilinx Virtex-II Pro 20 chip, is the centerpiece of the board controlling all other peripheral chips. It contains two embedded PowerPC chips which are to be used as a microcontroller for the unit or in the future also to run embedded Linux on it.

Figure 5 shows a photograph of the assembled IOM PCB with its 1,654 parts. Altogether there are 146 different parts on the board and the PCB has an overall of 7,128 pins. Ninety-eight percent of all the SMD components could be placed automatically by our pick&place tools and only 30 parts had to be populated by hand beside all the through-hole connectors. The board is 16" x 5.6" in size and is powered by standard 56W Thinkpad certified international power supplies.

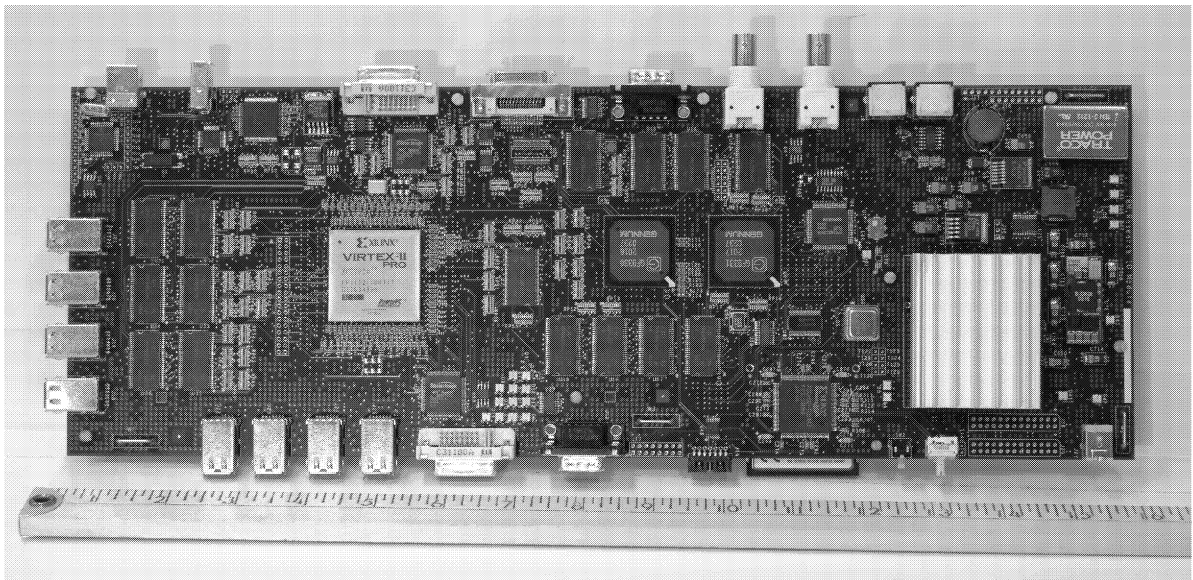

Figure 5: Photograph of the fully populated Input/Output Module (IOM) after PCB assembly

3.1.2 Input/Output Module (IOM) Specifications

Figure 6 shows the IOM specifications at a glance. HD-SDI is compliant to SMPTE 292 and SMPTE 274. It has been programmed to use the HD-SDI signal from the Ikegami HDL-40 camera which is 1920x1080@60Hz progressive. The DVI input and output is able to go up to 165MHz as specified by the DVI 1.0 standard.

Category	Parameter	Value	Comment
Inputs	HD-SDI DVI-D CameraLinkTM	1.495 Gb/s 3.96 Gb/s (max. 165 MHz pixel CLK) 2.38 Gb/s	SMPTE 292M Compliant to DVI 1.0 -
Outputs	DVI-D HD-SDI Infiniband	3.96 Gb/s (max. 165 MHz pixel CLK) 1.495 Gb/s 600 Mb/s to 3.125 Gb/s	Compliant to DVI 1.0 SMPTE 292M RocketIO, reconfigurable
Control Interfaces	RS232 & Aux. USB1.1 IEEE1394a	115kb/s 12Mb/s 400Mb/s	Others: Keyboard Mouse
FPGA Embedded CPU	Rocket-IO 2x Power PC	Aurora/Infiniband Embedded Linux optional	Infiniband 1x connectors
PC Board	16-layer	16" x 5.6" x 0.093", 0.61kg/1.35lb	Weight fully populated
Chassis	0.045" steel	16.5" x 5.75" x 1.5" , 1.54kg/3.40lb	Total weight 2.15kg/4.75lb
Power	Standby Typical	~ 8.7 W (without input signal), ~ 19.8W (with input signals)	Fully programmed Simultaneous HD-SDI&DVI
Memory	Deinterlacer Frame buffer PowerPC	96 MByte SDRAM 96 MByte SDRAM 32 MByte SDRAM	Upgrade by 2x possible
Ext. storage		Compact flash, Microdrive	Embedded Linux storage

Figure 6: Summary table of specifications of the Input/Output Module (IOM)

During the project we used exclusively RS232 as control interfaces due to easier software implementation even though USB 1.1 and IEEE1394a are also provided by the hardware. The modular interconnection is done via Aurora protocol which is available in the Infiniband 1x connectors. The choice of these connectors leaves then the option open to use Infiniband protocol in the future if required. The Gennum deinterlacer and motion-coprocessor have their own memory aside from the frame memory which is accessible through the FPGA. The compact flash is primarily used to store boot-time FPGA configurations and they can easily be exchanged for new firmware updates.

3.1.3 Input/Output Module (IOM) Packaging

In order to protect the PCB board and the sensitive electronics, we designed a metal enclosure out of folded steel which was lasercut precisely. The enclosure also guides the airflow in a defined channel limited by the enclosure and therefore improves cooling of the components of the PCB board, especially the Gennum chipset, the FPGA and the DC/DC converters.

Figure 7 and **Figure 8** show photographs of the packaged Input/Output modules suitable for 19 inch rack mounting. The height is 1U or 1.75 inches. All the camera input signals are accessible in the front while the DVI output, the four Aurora channels and the compact flash are in the back.

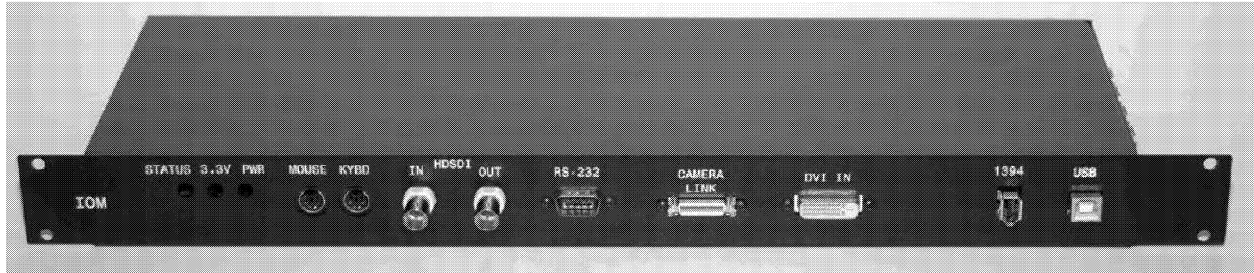

Figure 7: Front view of IOM 19"-rackmountable 1U module with digital video capture interfaces

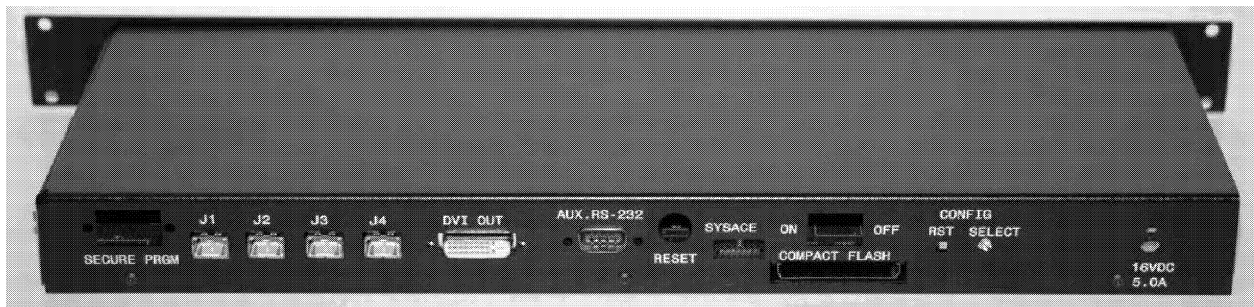

Figure 8: Back view of IOM 19"-rackmountable 1U module (J5 through J8 on the left side are additional high speed channels)

3.2 Image-Processing Module (IPM)

As a module on the transmitting side of the “BlueEagle” system, the IPM is taking care of the video encoding and on the receiving side it needs to do the decoding of the video information. It was decided that we dedicate a whole separate module for this functionality due to the complexity of the compression algorithms and to keep the functionalities separate for easier code development.

As indicated in Section 2, this was achieved by designing the IPM such that it can accomplish both functions by different firmware on the FPGA, but identical hardware on both the transmitting and receiving side.

3.2.1 Image Processing Module (IPM) Design

Figure shows the block diagram of the IPM. It has been designed specifically for image processing by pairing the Xilinx Virtex-IIPro 70 FPGA with 192Mbyte of DDR and 9Mbyte of QDR in order to have high bandwidth available to memory. In the IOM we used SDRAM only. In addition to that we put a 600MHz TI DSP on the board in case the FGPA will get overloaded with tasks. Main interface with the other modules is the Aurora protocol accessible on Infiniband 1x connectors. In this board we also implemented the first time the chip scope connector for faster debugging capabilities.

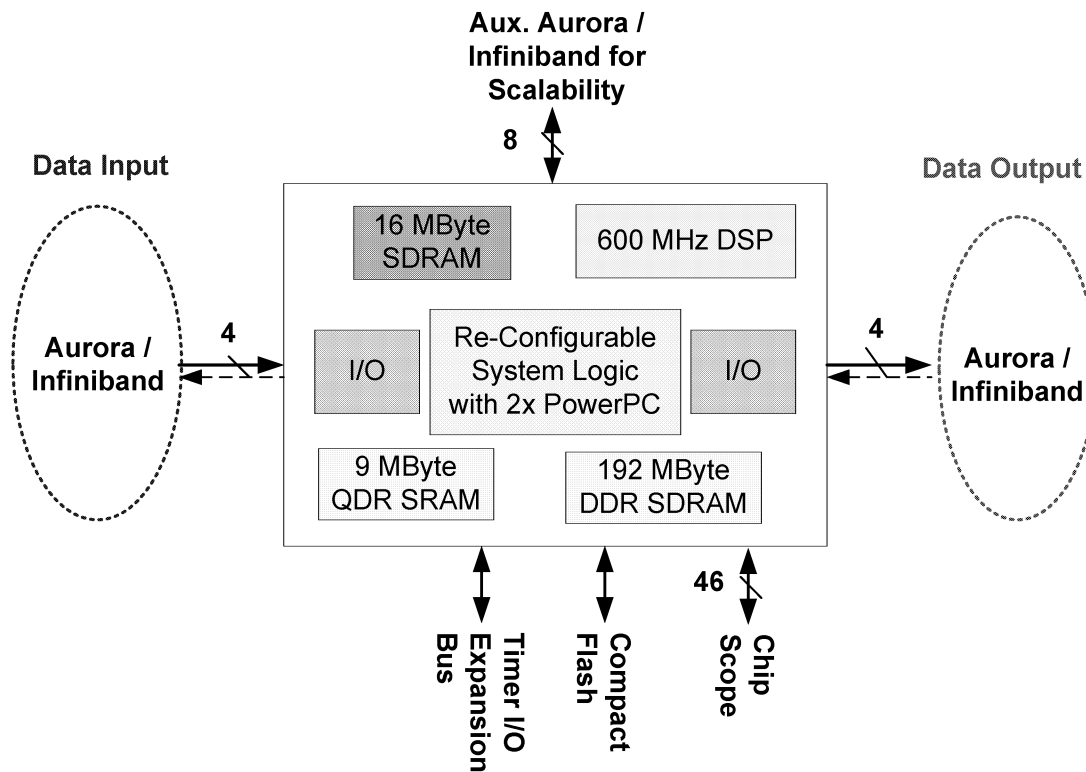

Figure 9: Image Processing Module (IPM) functional block diagram

Figure 10 shows a photograph of the assembled IPM PCB with its 1,790 parts. Altogether there are 144 different parts on the board and the PCB has an overall of 10,101 pins. Ninety-eight percent of all the SMD components could be placed automatically by our pick&place tools and only 36 parts had to be populated by hand beside all the through-hole connectors. The board is 16” x 5.6” in size and is powered as the IOM by standard 56W Thinkpad certified international power supplies.

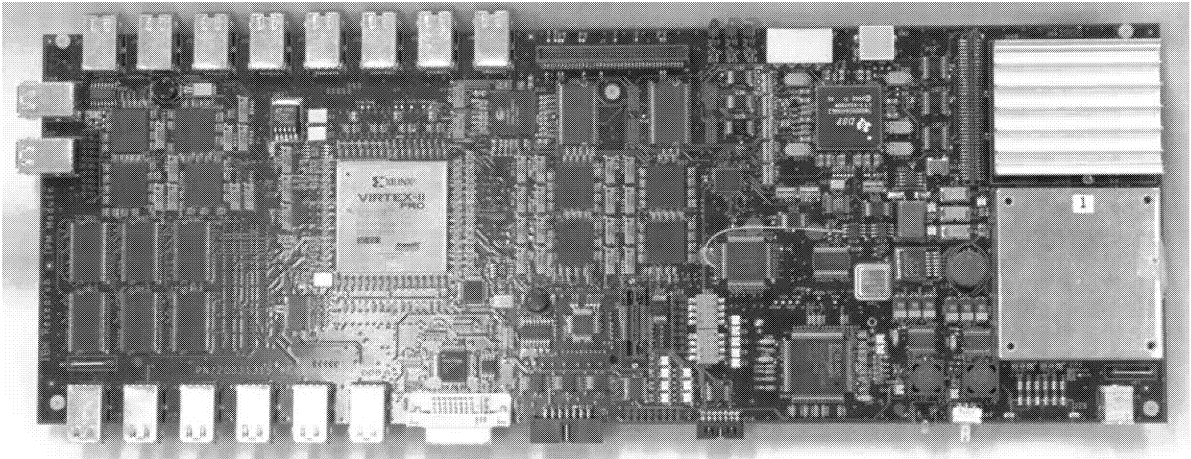

Figure 10: Photograph of the fully populated Image Processing Module (IPM)

3.2.2 Image-Processing Module (IPM) Specifications

A summary of the IPM specifications is shown in **Figure 11**. The IPM's IO capability is mainly based on Rocket-IO from the FPGA in order to provide high bandwidth (600Mbps to 3.125Gbps per link). In total 14 Rocket-IO links with Aurora protocol are available on the Infiniband 4x connector.

Category	Parameter	Value	Comment
Inputs	Infiniband	600 Mb/s to 3.125 Gb/s	14 Possible Links. Rocket-IO, reconfigurable
Outputs	Infiniband DVI-D	600 Mb/s to 3.125 Gb/s 3.96 Gb/s (max 165 MHz pixel CLK)	14 Possible Links. Rocket-IO, reconfigurable Compliant to DVI 1.0
FPGA Embedded CPU	Rocket-IO 1x Power PC	Aurora/Infiniband Embedded Linux optional	Used Infiniband 1x connectors
PC Board	16-layer	16" x 5.6" x 0.093", 0.64kg/1.51lb	Weight fully populated
Chassis	0.045" steel	16.5" x 5.75" x 1.5", 1.59kg/3.39lb	Total weight 2.23kg/4.90lb
Power	Standby Typical	~10W (without input signal), ~16W (with input signals)	Fully programmed With Aurora links active
Memory	Frame buffer/PPC Coeff. buffer DSP buffer	192 MByte DDR SDRAM 9 MByte QDR SRAM 16Mbyte SDRAM	Upgrade by 2x possible Upgrade by 2x possible
Ext. storage		Compact flash, Microdrive	Embedded Linux storage

Figure 11: Summary table of the specifications of the Image Processing Module (IPM)

3.2.3 Image-Processing Module (IPM) Packaging

In order to protect the IPM PCB board and the sensitive electronics, a metal enclosure made out of folded steel which was lasercut precisely. The enclosure also guides the airflow in a defined channel limited by the enclosure and therefore improves cooling of the components of the PCB board, especially the VP70 FPGA, the TI DSP and the DC/DC converters.

Figure 12 and **Figure 13** show photographs of the packaged Input/Output modules suitable for 19 inch rack mounting. The height is 1U or 1.75 inches. The input and the output Aurora links were configured to come into the back in order to make the packaging as easy as possible. The assignment is defined in the firmware as follows: on the IPM on the transmitting side we have it configured as four inputs and one output; on the IPM at the receiving side it is configured as one input and four outputs.

The IPM has back the same compact flash interface like the IOM which carries the FPGA configurations and could be used in the future even to run embedded Linux. This makes upgrading the firmware easy and allows storing several configurations which can be stored on the flash card.

The DVI output on the IPM was only used for debugging purposes so far to monitor the video data stream.



Figure 12: Front view of IPM 19"-rackmountable 1U module with the eight auxiliary high speed interfaces and status LEDs in the front

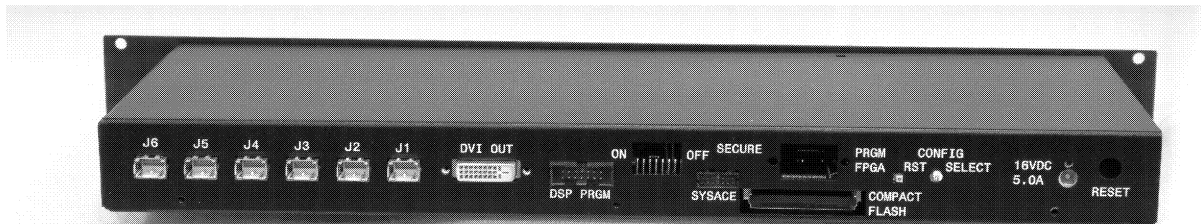

Figure 13: Back view of IPM 19"-rackmountable 1U module from where the connections to the IOM and NIM are made as well the compact flash for the FPGA configurations is being inserted

3.3 Network Interface Module (NIM)

The NIM module is either receiving video and control packets from the IPM on the transmitting side or transmitting packets to the IPM on the receiving side. The NIM was the only module designed such that the embedded code on the transmitting and receiving side are identical. The NIM takes care of the networking stack of the “BlueEagle” packet protocol on UDP. The NIM was also designed with two DVI outputs to allow future use as remote desktop without hard drive for secure environments.

3.3.1 Network Interface Module (NIM) Design

Figure 14 The NIM-2 module has 512MByte DDR memory on board and can accept up to four Aurora links as inputs allowing then future scaling to 4x HDTV resolution. Two channels were converted to 2Gbps Fibrechannel to allow attachment of external Fibrechannel hard drives. IEEE1394a is implemented such that it can transfer high speed data up to 400Mbps. The hardware supports 100/1000M Ethernet. The chipscope interface was implemented the same way as on the IPM.

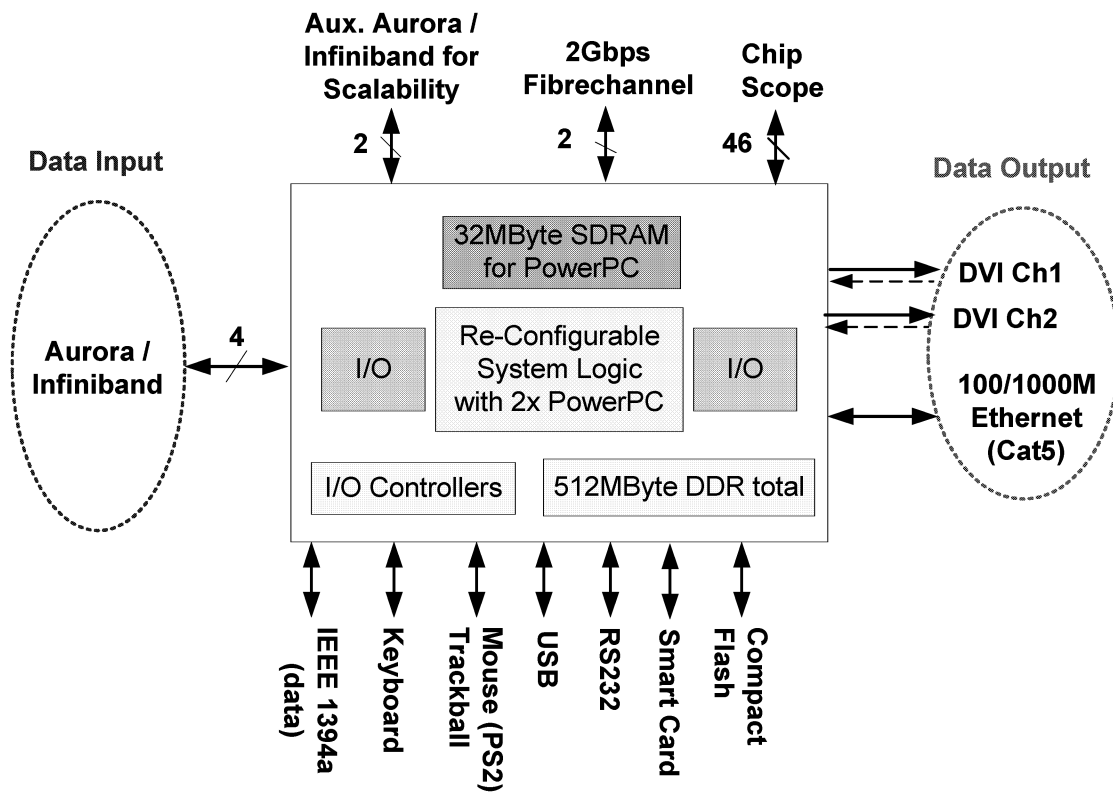

Figure 14: Network Interface Module (NIM) functional block diagram

Figure 15 shows a photograph of the assembled NIM PCB with its 1,658 parts. Altogether there are 84 unique parts on the board and the PCB has an overall of 6,629 pins. 98% of all the SMD components could be placed automatically by our pick&place tools and only 35 parts had to be populated by hand beside all the through-hole connectors. The board is 16” x 5.6” in size and is powered as the IOM by standard 56W Thinkpad certified international power supplies

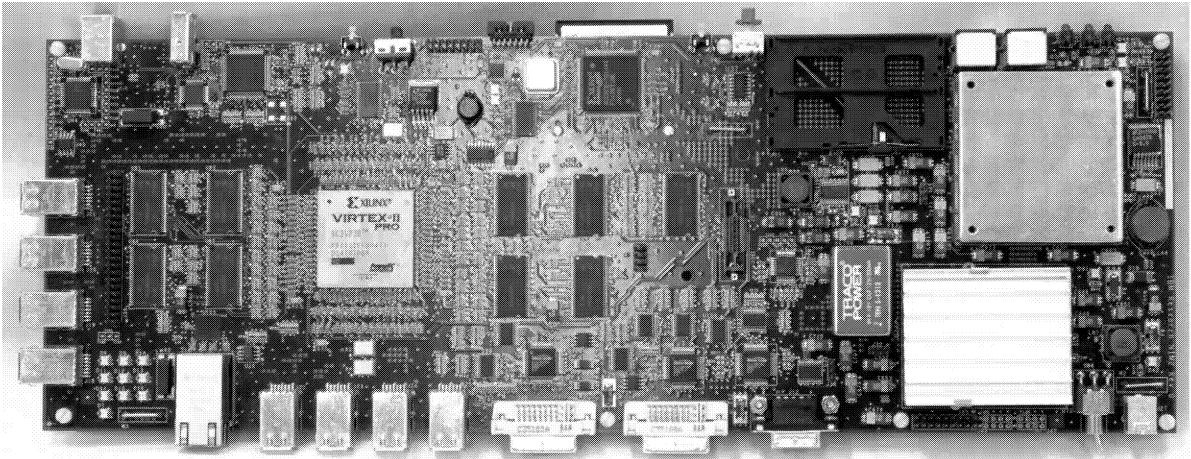

Figure 15: Fully populated Network Interface Module (NIM) after PCB assembly

3.3.2 Network Interface Module (NIM) Specifications

Figure 16 shows a summary of the NIM specifications. The two DVI channels can be configured either in dual DVI mode using both connectors, in dual-link DVI mode using the primary connector or single-link DVI using the primary connector. All other specifications of the connections are similar to the IOM and IPM.

Category	Parameter	Value	Comment
Inputs	Infiniband	600 Mb/s to 3.125 Gb/s	RocketIO, reconfigurable
Outputs	Primary DVI-D	3.96 Gb/s (max. 165 MHz pixel CLK)	Compliant to DVI 1.0
	Secondary DVI-D	3.96 Gb/s (max. 165 MHz pixel CLK)	
	Ethernet	100/1000 Mb/s	RocketIO, reconfigurable
	Infiniband Fibrechannel	600 Mb/s to 3.125 Gb/s 1Gb/s or 2Gb/s	
Control Interfaces	RS232	115kb/s	Others: Keyboard Mouse
	USB1.1	12Mb/s	
	IEEE1394a	400Mb/s	
Smartcard	8-contact		
FPGA Embedded CPU	Rocket-IO 2x Power PC	Aurora/Infiniband/Fibrechannel Embedded Linux optional	Infiniband 1x connectors
PC Board	16-layer	16" x 5.6" x 0.093", 0.68 kg/1.59 lb	Weight fully populated
Chassis	0.045" steel	16.5" x 5.75" x 1.5", 1.47 kg/3.47 lb	Total weight 2.15 kg/5.06lb
Memory	Frame buffer PowerPC	512 MByte DDR 32 MByte SDRAM	Upgrade by 2x possible
Ext. storage		Compact flash, Microdrive	Embedded Linux storage

Figure 16: Summary table of specifications of the Network Interface Module (NIM)

3.3.3 Network Interface Module (NIM) Packaging

In order to protect the IPM PCB board and the sensitive electronics, a metal enclosure made out of folded steel which was lasercut precisely. The enclosure also guides the airflow in a defined channel limited by the enclosure and therefore improves cooling of the components of the PCB board, especially the VP70 FPGA, the TI DSP and the DC/DC converters.

Figure 17 and **Figure 18** show photographs of the packaged Input/Output modules suitable for 19 inch rack mounting. The height is 1U or 1.75 inches. The input and the output Aurora links were configured to come into the back in order to make the packaging as easy as possible. The assignment is defined in the firmware as follows: on the IPM on the transmitting side we have it configured as four inputs and one output; on the IPM at the receiving side it is configured as one input and four outputs.

The IPM has back the same compact flash interface like the IOM which carries the FPGA configurations and could be used in the future even to run embedded Linux. This makes upgrading the firmware easy and allows storing several configurations which can be stored on the flash card. So far, the DVI output on the IPM was only used for debugging purposes to monitor the video data stream.

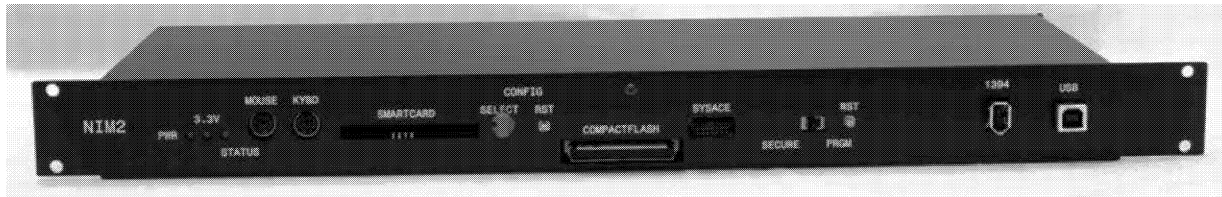

Figure 17: Front view of NIM 19"-rackmountable 1U module with smart card reader

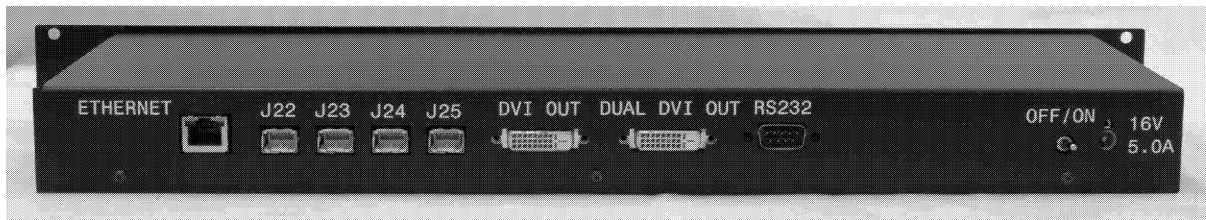

Figure 18: Back view of NIM 19"-rackmountable 1U module with dual DVI outputs and Ethernet RJ45 connector

3.4 Overall Packaging of “BlueEagle” System

Figures 19 & 20 Rather than having the individual modules being stacked directly on top of each other we staggered them in a 3U high desktop rack. This also allowed us to integrate the power strip and the Thinkpad AC/DC power supplies into the same box and make it much easier to move the system around even though it added weight. Certainly it allows the cables to be plugged in securely with a lower risk to slip out. Compared to the enclosures for the individual modules, this box was acquired as an off-the- shelf item. All the other enclosures were custom designed for each module.



Figure 19: Fully packaged “BlueEagle” transmitter system unit



Figure 20: Fully packaged “BlueEagle” receiver system unit using identical hardware modules as in the transmitter system unit but programmed differently to accommodate functionality

3.5 Cameras and Pan&Tilt&Zoom (PTZ) Units used with “BlueEagle” System

A few box camera systems with appropriate PTZ units were considered during the “BlueEagle” project. The following mentions three systems which were considered in the BlueEagle design accommodating their different video interfaces. The system is not limited using other camera systems. They could be accepted with no or minor changes if the physical interfaces are identical.

3.5.1 Ikegami HDL-40 camera with Fujinon Motorized Lens and Pan&Tilt System

Figure 21 Prior to the start of this project, IBM Research was in the position to buy with capital money a high- end box camera system. We bought an Ikegami ® HDL-40 box camera. The camera has three CCD sensors, each at 1920x1080 resolutions, and offered at the time one of the best signal to noise rations. It transmits the video signal digitally according to the SMPTE HD-SDI standard as a 1920x1080 format at 60Hz frame rate interlaced. The lens attached to the camera is a high-end motorized HD lens from Fujinon®. The Pan&Tilt unit is also a professional unit from Fujinon which is weight balanced to carry camera and lens. We used this camera system as a reference system for the “BlueEagle” system because of its image quality and sensitivity.



Figure 21: Ikegami HDL-40 camera with Funjinon motorized HD lens and Funjinon Pan&Tilt system

3.5.2 Silicon Image Camera with ESI Pan&Tilt and Computar motorized lens

A more cost-effective solution by a factor of about 8 is the combination of a Silicon Image SI-1920HD-RGB camera, Computar M10Z1118MSP motorized lens and ESI DPT-115 Pan/Tilt head. **Figure 22** and **Figure 23** show the camera module with Computar motorized lens and its integration with the ESI Pan/Tilt unit, respectively.

The sensor used in the Silicon Imaging SI-1920HD-RGB 2/3" format camera is a single chip CMOS sensor from Rockwell with a bayer color pattern. The camera interface is CameraLink™ and the sensor can be read out up to 60Hz frame rate at 1920x1080 pixel resolution. However, in our experiments we used the sensor at the same video timing as on the Ikegami camera. This allowed for longer integration time and for a better signal to noise ratio. Obviously, the Ikegami HD camera is still superior in all respects. But it can be anticipated that CMOS sensors will catch up and offer other helpful features, such as windowing which allows to read out section of the sensor at higher speed.



Figure 22: SI-1920HD-RGB Camera Mounted on Computar H10Z1118MSP Motorized 2/3" Lens



Figure 23: ESI DPT-115 Pan/Tilt w/ Computar H10Z1118MSP Lens w/ SI-1920HD-RGB Camera

3.5.3 ISG camera

The “BlueEagle” system is prepared to be connected to the prototype camera from ISG which provides four DVI channels simultaneously. The ISG camera is a single chip CMOS camera with 3840x2160 pixels and a bayer color filter pattern on top of the sensor. Multiple channels can be handled by the “BlueEagle” system by streaming the signals through modules in parallel and share boundary data through the auxillary Aurora channels on the Modules (see **Figure 24**)

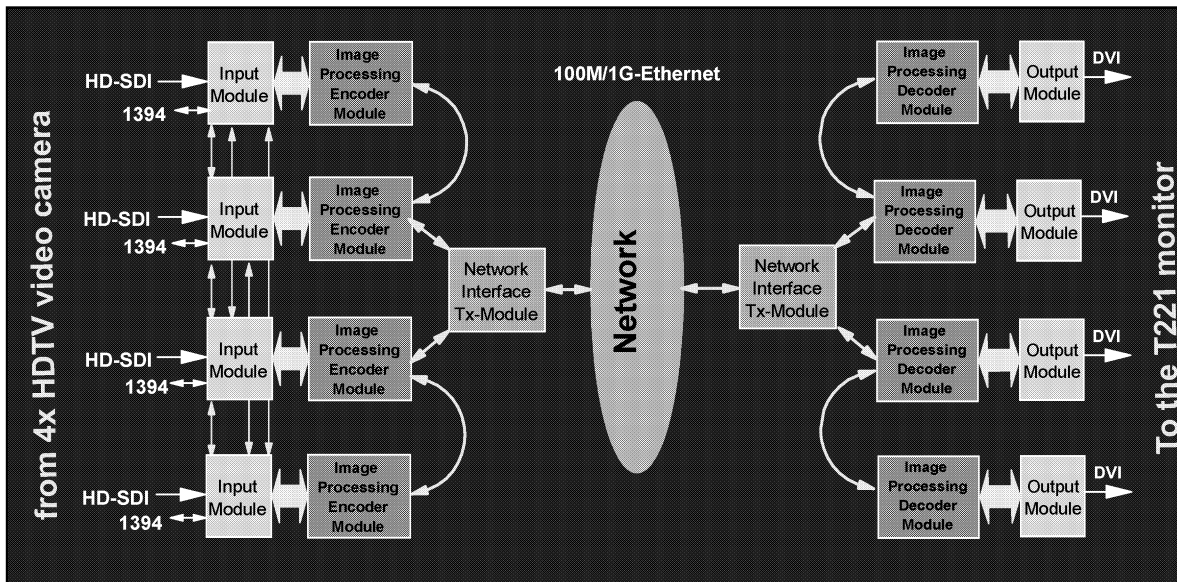

Figure 24: Interconnections between scaled-up “BlueEagle” system to accommodate for example transmission of digital signal of 4x HDTV resolution (3840x2160)

3.6 “BlueEagle” System in a Surveillance Application with IBM’s Peoplevision Software

Figure 25 an implementation of the “BlueEagle” system in a surveillance application together with the PeopleVision software from IBM Research which is selecting the location and size of the region of interest on the transmitting side near the camera. It is the configuration how the systems are installed at two US Army sites. In case of the site installations, because of the close proximity of monitor and camera, we also allow a so-called split screen mode in which the T221 shows on the right side the original camera signal converted to DVI and the left side the receiving image going through the whole BlueEagle system.

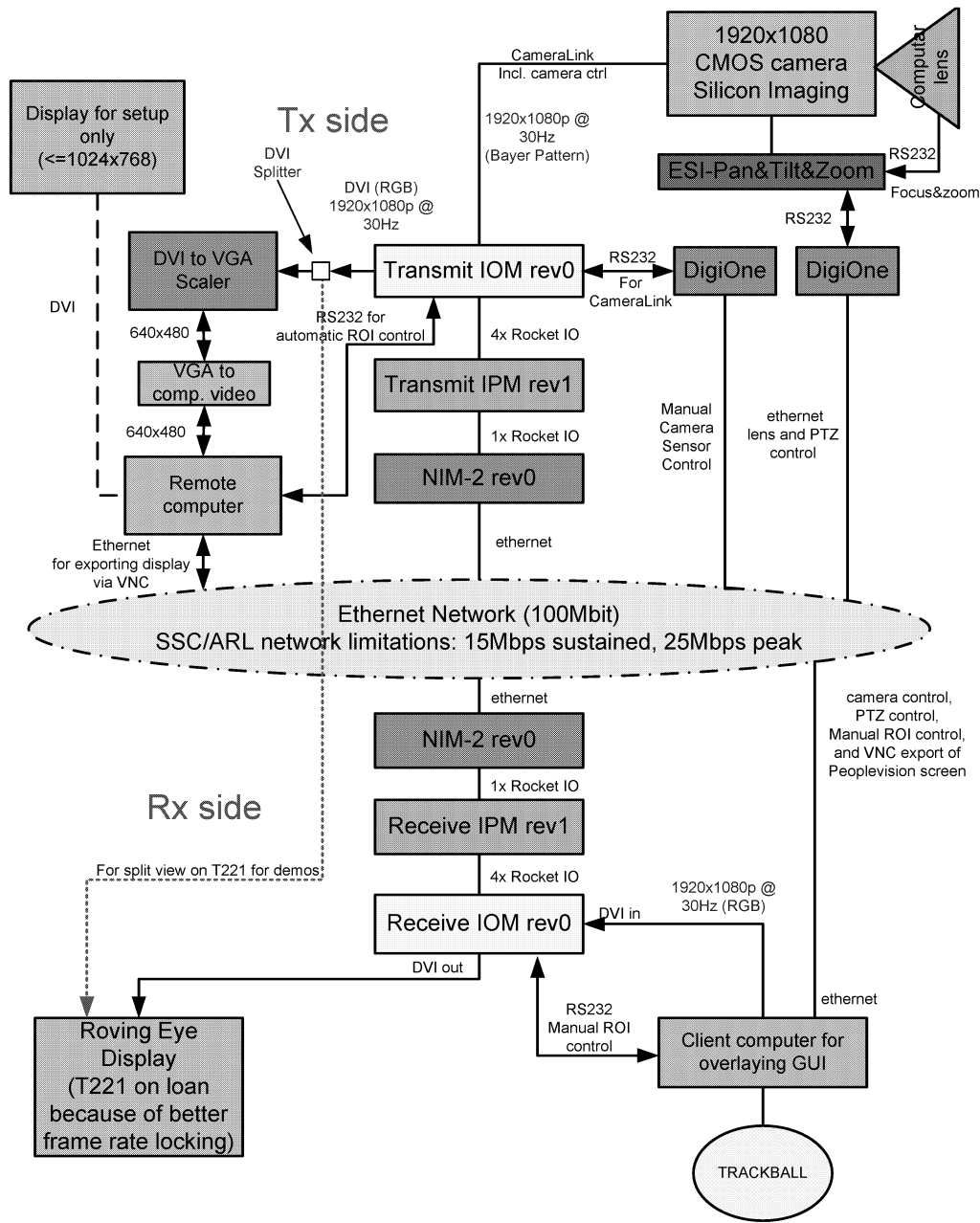

Figure 25: “BlueEagle” system block diagram with IBM PeopleVision surveillance software

4. Software for the “BlueEagle” System

4.1 Graphical User Interface (GUI)

The WindowBE program was designed to both provide an interface for visualizing the region of interest (ROI) and background images provided by the IOM and allowing the user to dynamically change both the parameters of the IOM and the image source through panning, tilting, zooming and/or focusing the camera. In addition, when connected to the SI image camera and ESI stage, the current deliverable system, defining and using camera presets along with iris control are also supported. By using a user selectable chroma-key the IOM replaces the pixels which match the chroma-key with appropriate image data.

The WindowBE program is a 32 bit windows program, which means that it will run on any Windows 95 and later Operating System. However, since it is optimally used with a wheel mouse and the wheel mouse was only introduced in Windows 2000, it is recommended that Windows 2000 or later Operating System be used.

The WindowBE program is designed to run in stand alone mode such that its entire input is manually controlled by the user. Along with the program a text file WindowBE.ini is also located in the same directory as the program. If necessary, as described later in this document, this file can be modified with any text editor. In addition, it is designed to be run in conjunction with the PeopleVision software. When run with the PeopleVision software, the PeopleVision software automatically loads the WindowBE program. The PeopleVision software can automatically control the position and size of the ROI by directly communicating with the WindowBE program. When the PeopleVision software is closed down the WindowBE program is also automatically unloaded.

4.2 Screen Layout

Three windows are presented by the WindowBE program, a ROI window, a background window, and a control window as shown in **Figure 26**. The chroma-key has been selected to be magenta, for this illustration.

As shown in **Figure 26** by the magenta colored areas, the ROI and background windows are superimposed on top of each other. The entire resolution of the HDD camera, which is 1920x1080 pixels, is comprised by these windows. The remaining bottom portion of the screen (i.e. 1920x120 pixels) is used for the user control window.

Along with presenting information about the ROI, the control window allows for controlling many hardware parameters. In particular, the frequency of updating the background, along with constraining the allowed background bandwidth, can be set to a multiplicity of values with slider bars.

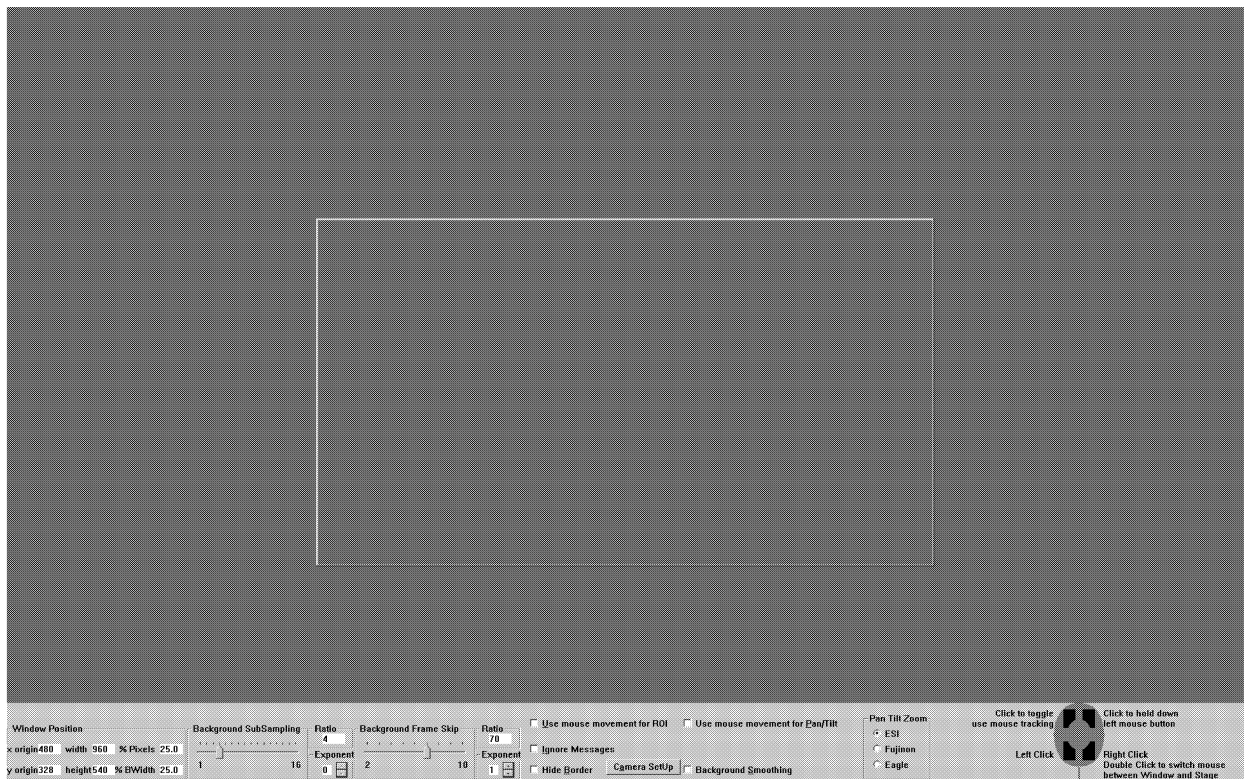

Figure 26: The WindowBE user interface

Several different user interface parameters, like linking the ROI movement to mouse movement, toggling on and off the ROI border, along with allowing manual or People Vision control of ROI movement, can be set. In addition, Pan/Tilt/Zoom and Focus of the camera is supported. Finally, a dialog box to control setting/going to Preset camera position, and looping through preset camera positions at selectable time increments is supported.

5. Utilities Developed in Support of “BlueEagle” System

5.1 Utility Software for Control of Silicon Imaging single CMOS Sensor HD Camera

A standalone Windows application program ESI_PanT.EXE has been written to integrate the control of both asynchronous ports.

This software consists of a simulated joystick control for the pan and tilt functions of the camera positioning system, as well as buttons for sending individual pan and tilt commands at user-selected speeds and choice of axes. There are sixteen preset camera positions which may be set which also include lens zoom and focus settings. Lens iris control cannot be preset and can only be controlled by its slider function. There also are slider functions for adjusting lens zoom and focus. There is an AUTO Pan mode which permits continuous panning of up to all sixteen preset pan/tilt camera positions, with user-selected hold times at each position of from 8 to 60 seconds.

In order to store a camera preset position, use the joystick control to position the pan/tilt head at the desired location, then use the zoom and focus sliders to adjust the zoom and focus. Click on the ‘GoTo Preset’ box which will then be labeled ‘Store Preset’ and then click on the desired ‘Preset n’ button. The ‘Store Preset’ label will be automatically changed back to ‘GoTo Preset’. The new preset information is now stored.

To go immediately to any stored preset position, simply click on the desired ‘Preset n’ button.

When first powering up the system or loading the application program, use the ‘Init’ button to initialize the basic settings for the SI-1920HD-RGB camera. Pressing this button sends a series of camera commands which will first check that the camera is connected and powered on, and will then set up the proper settings for color and the proper clock frequency for 1920 x 1080 @ 60Hz operation. There is a window where the camera responses for each command will be displayed for the user.

The camera contains a set of default settings which consists of all 42 of the SI-1920HD-RGB camera registers. There are also three Preset storage locations (Preset 1, Preset 2, and Preset 3) which allow the user to store a complete set of camera registers which have been altered by the user to adjust them for a specific camera application. The camera will boot up whenever its power is cycled off and then on.

The register set that the camera loads upon boot-up will depend upon previous setup commands issued by the user. For example, if an “ld1” command has been issued by the user, then the camera will boot up to the register set which the user has saved in the Preset 1 register storage location. This is the way that the camera can return to normal operation using the user’s specific register settings for a previously set-up camera application.

Should there be any problem which might be associated with bad register data in one of the Preset storage locations, then the recovery procedure would be to issue an “ld0” camera command to force the camera to boot up with the manufacturer’s default settings, and then power cycle the camera. Then the user can run the ‘Initialize’ command from the GUI which will update several of the registers to the user’s specific application. Finally, this restored set of registers can be copied into the selected Preset location (e.g. by issuing an “le1” camera command). Now it is possible to issue an “ld1” camera command which sets the camera up to boot up from Preset 1 at the next camera power off/on cycling.

It is also possible to load the camera registers from the Preset storage locations by issuing the simple one-character commands (i.e. issue “1” to load from Preset 1, “2” to load from Preset 2, and “3” to load from Preset 3). This feature provides the flexibility of switching between several sets of camera settings in

order to quickly adjust to different lighting conditions, for example, or perhaps to simply make visual comparisons between settings.

Initialization Camera Commands: (Executed when GUI 'Initialize' button is pressed)

```
"s"           Get Camera Status
"ld1"        Select Preset No. 1 Settings for Camera Bootup
"lyf40032"   Set Reg f4H for Camera Individual Analog Gain Controls for RGB Mode
"ly7000c0"   Set Reg 70H Bit 7 to Enable Gamma Curve
"lg766690"   Set RGB Analog Gains (B=7, G1=6, G2=6, R=6), 4 Black Offsets to 90H
"Ic34ae05"   Set Camera Clock Frequency to 75.0 MHz      (for 1920 x 1080 @ 60 Hz)
or
"Ic34d20f"   Set Camera Clock Frequency to 37.5 MHz     (for 1920 x 1080 @ 30 Hz)
"le1"        Save all camera register values into Preset 1 location
"s"          Get Camera Status (leaves camera status response on GUI display)
```

Individual camera control commands may be selected from a list or written explicitly into the 'Camera CMD' text box and then clicking on the 'SEND Camera CMD' button.

Figure 27 shows a screen capture of the utility program for the camera sensor and the PTZ unit attached to it.

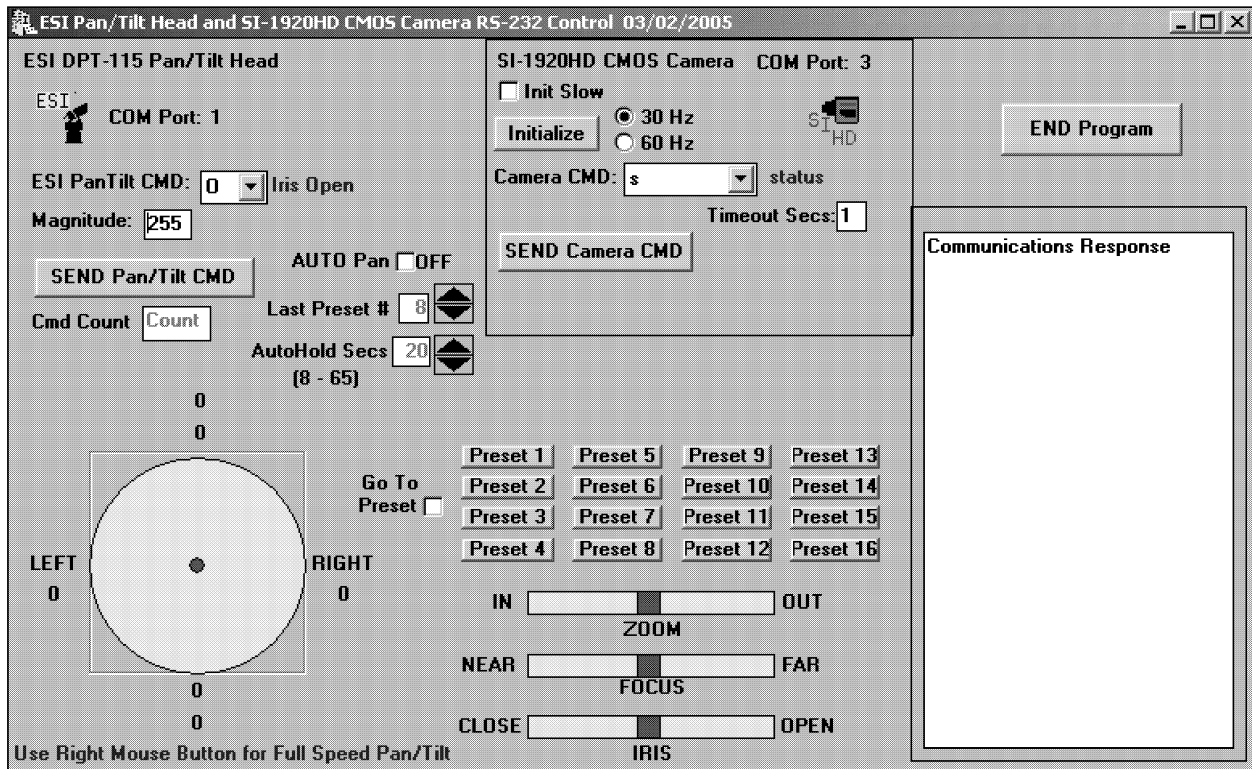

Figure 27: Screen capture of the Utility Program Manually controlling the CameraLink Cameras

5.2 Video Server to Capture Uncompressed Video Data in Real Time

A standard IBM e-server was acquired independent of this contract and specialized software was written which will record and play back HD YCrCb 4:2:2 data at 30 Hz interlaced. The server was modified to include dual processor 2.66 GHz CPUs and a SCSI RAID system consisting of 4 SCSI disks with a total disk capacity of 136 GB. A 20 minute movie section and be recorded and played back without skipping a single frame. We utilized a PCI video capture card from DVS, which we had acquired prior to this contract, to record and play back the data. To capture uncompressed video at the above resolution, the server must store data at a sustained rate of over 120 MB/second. It was ascertained empirically that storing data through an Operating System file system was much too slow for the above task, so that we needed to directly write to the disk on a sector by sector basis. Since directly writing to the disk can easily corrupt the Operating system, much caution and checking was built into the software. In addition, the dual processor architecture was taken advantage of by writing multi-threaded software such that the load on both CPUs was balanced. In addition, for debug purposes, a helper program was written which converts and displays the YCrCb data into RGB format on a frame by frame basis.

The video server allows us to do a detailed analysis of the quality of compression in our ROI system. In addition, it will enable storing and retrieving clips such that our hardware and the associated PeopleVision software can be tested, demoed, and improved by replaying the same test sequences again and again. We also purchased removable hard drive cartridges to be able to archive desired video sequences.

5.3 Digital Packet Video Link Protocol

During the course of this contract we were in parallel active in the VESA standards and were spearheading the effort to make the Digital Packet Video Link (DPVL) into an industry standard. The committee was launched under IBM's leadership on April 24, 2002 and the standard was approved on April 18, 2004. **Figure 28** shows the packet definition of the basic header under DPVL and **Figure 29** shows the timing format of the packets under the DPVL standard.

Field Name	Bit Length	Description
HTYP	1	Header Type ("1"=Basic/"0"=Extended)
MBUF	2	Defines to which buffer in the monitor the pixel data gets written to: "00" pixel data is written to the refresh buffer "01" pixel data is written to the offline buffer "11" pixel data is written to all buffers "10" reserved
SCEND	1	"1" indicates last packet of a current scene
XORG	16	X (horizontal) origin of the update rectangle 0 to 65535 (0000h to FFFFh)
XSIZE	12	Update Rectangle Width - 1 1 to 4096 (000h to FFFh)
HOFF	4	Numbers of pixels (0...15) to skip at start of each line (0h to Fh)
YORG	16	Y (vertical) origin of the update rectangle 0 to 65535 (0000h to FFFFh)
YSIZE	12	Update Rectangle Height - 1

Figure 28: Packet definition of the basic packet under DPVL protocol

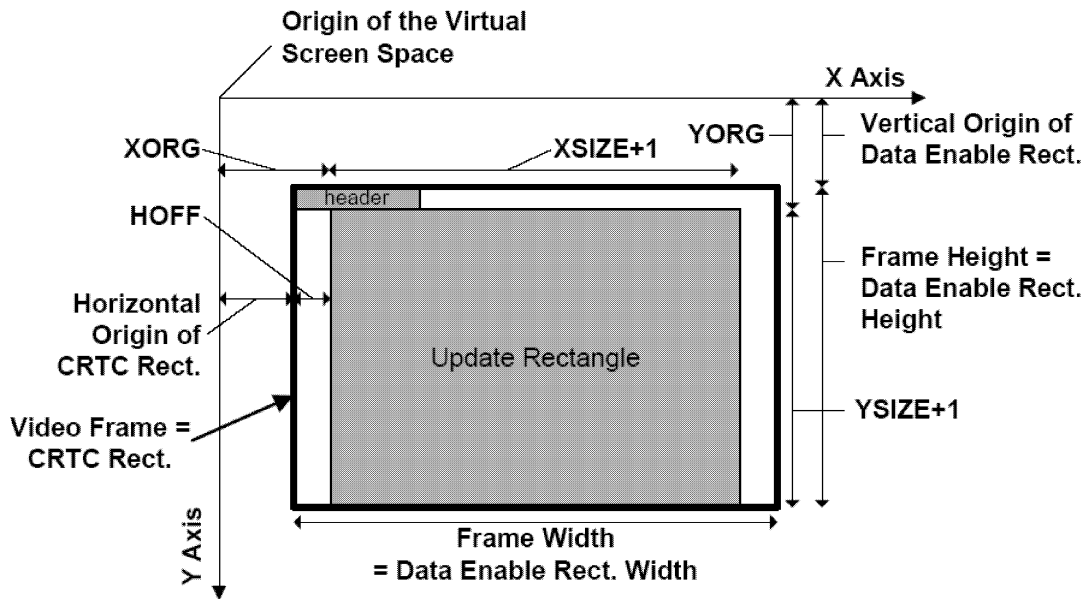

Figure 29: Video data and packet timing format in the DPVL protocol

More information about DPVL can be downloaded from the VESA website, specifically the 90-page standard document describing the DPVL protocol in all detail.

Figure 30 illustrated the use of the IOM and the NIM from the “BlueEagle” system for prototyping solutions using the DPVL protocol and future packet protocols over IP.

- Display devices are becoming high content.
- Virtual clients w/o hard drive demand multiple monitor support.
- Limitation: Bandwidth
- Solution: DPVL
 - Video stream protocol
 - Selective refresh
 - Supports monitor daisy-chain

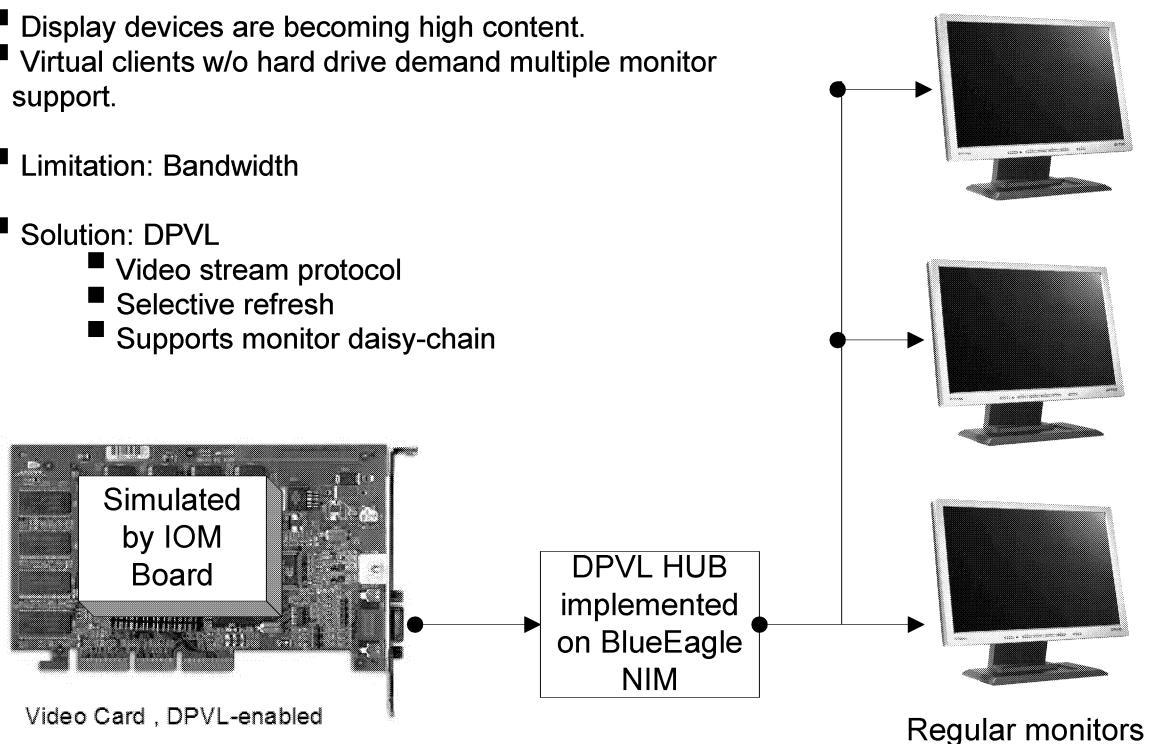

Figure 30: Example how BlueEagle IOM and NIM are being used for DPVL prototyping

6. Delivery of Two “BlueEagle” Systems

The first “BlueEagle” system was hand delivered to ARL in Adelphi on June 8, 2005. The system was setup as it is illustrated in **Figure 25**. **Figure 31** and **Figure 32** show the system setup on an optical bench in the ARL lab. On the left side is the transmitting side (Tx) of the system and on the right side the receiving side (Rx) with an IBM T221 monitor. The Silicon Imaging 3Mpixel CMOS camera with its PTZ unit is mounted on the top of the shelf on the left side. The communication between the two sides of the system is being entirely handled over the internal ARL 100Mbit-Ethernet network. The LCD monitor on the left side is to the remote computer (see **Figure 25**, PC not visible in picture) which contains the Peoplevision application and also shows the output of the down sampled image which is fed into the remote computer. The IBM PC below the T221 contains the “BlueEagle” GUI application and allows overall system control.



Figure 31: Photo of the “BlueEagle” prototype system setup on the optical bench at ARL

Due to the proximity of the “BlueEagle” transmitter and receiver we decided to show the system in a so called ‘split screen’ mode. **Figure 33** is a photo of the T221 screen showing on the left side the captured signal at the DVI output (1920x1200) of the receiving side of the system and the right side the CameraLink signal to DVI from the IOM of the transmitting side. T221 was programmed in this mode to accept asynchronous video signals. The left side acts as a master channel to which the right side is being synchronized to (by switching the cables to the T221 one could invert that sequence). For this purpose we inserted at the output of the Tx IOM a DVI splitter which allows to replicate the DVI data signal and take it to the secondary channel of the T221. This mode allows the simultaneous viewing of both video streams on a single display device in full resolution and allow us to evaluate system behavior. A second “BlueEagle” system was setup a month later on July 11 in Natick in a similar configuration.



Figure 32: Photo of the “BlueEagle” prototype system setup on the optical bench at ARL

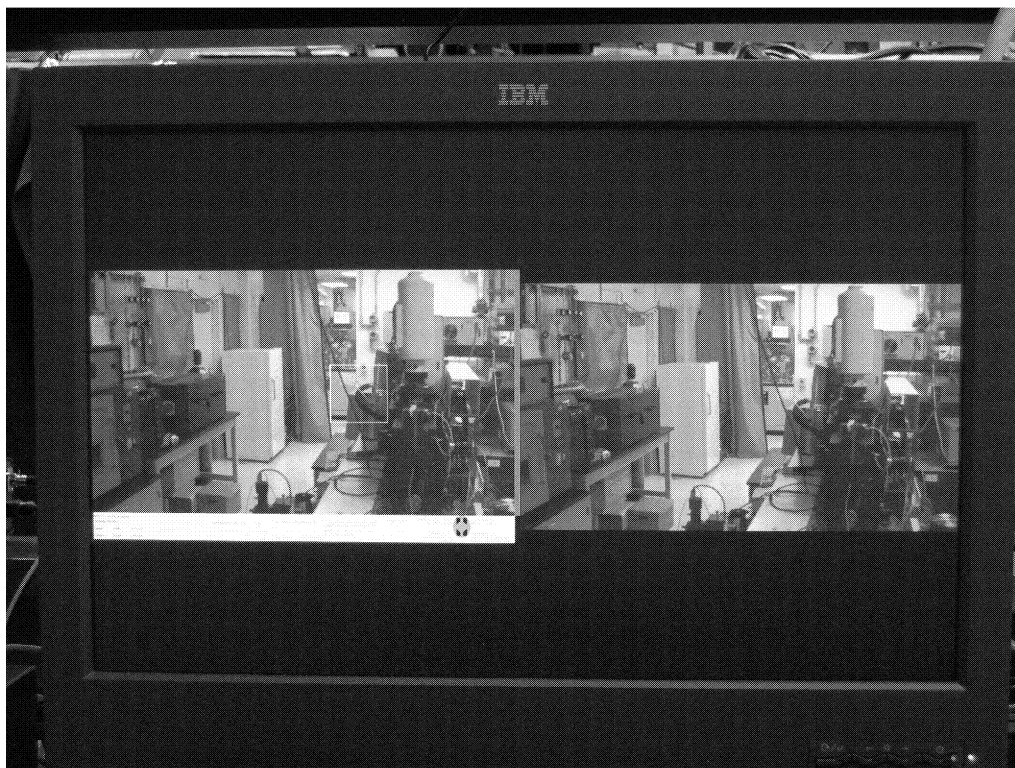

Figure 33: Photo of the T221 screen showing on the left the 1920x1200 received image on the receiving side of the system and on the right the 1920x1080 image captured from camera converted to DVI format

7. Conclusions

The “BlueEagle” system created under this contract is a powerful prototype system which allows running experiments in different visualization scenarios primarily from live high-resolution camera feeds. It has been demonstrated that the system can be adapted to different situations without changing any hardware. Building the “BlueEagle” system in a modular way was not only highly beneficial from a budget point of view but also from a risk management point of view because each of the three new modules (IOM, IPM and NIM) designed under this contract have the complexity of a PC motherboard. Further miniaturization is certainly possible with the latest FPGA chips coming out from Xilinx later this year but it was not in our budget to pursue that at this point.

The modular design of the system opens up opportunities to use individual modules for other purposes. We use for example the IOM for a potential baseband implementation on the 60GHz wireless range for wireless high image content video transmission. Currently the combination of IOM and NIM is in use by a summer student who prototypes an implementation of DPVL. Biggest issue right now is the limitation of resources for writing embedded code for the system.

Two “BlueEagle” systems have been setup in two different locations, one at ARL in Adelphi and one at SSC in Natick. Throughout the remainder of the year we plan to have a few more upgrades to the deployed BlueEagle system and we might use a follow-on of the IOM together with a board which contains a cell processor for high-end imaging and video surveillance applications. Still, in both cases a lot of time has to be spent to write the embedded respective code.

Distribution List

One report to:

Henry Girolamo, Program Manager
U.S. Army Soldier Systems Center
ATTN: AMSSB-RSS-D(N)
Kansas Street
Natick, MA 01760-5020

Three reports to:

Patricia J. Fox
Grants Officer and Contracting Officer
US Army Robert Morris Acquisition Center
RTP Contracting Division
(919)549-4272 or DSN 832-4272
Fax (919)549-4388
patricia.fox@us.army.mil

One report to:

Dr. David Morton
Army Research Laboratory
AMSRL-SE-EO
2800 Powder Mill Road
Adelphi, MD 20783-1197
dmorton@arl.army.mil

