

Prepared in cooperation with the
South Dakota Department of Environment and Natural Resources
and the West Dakota Water Development District

Selected Data for Wells and Test Holes Used in Structure-Contour Maps of the Inyan Kara Group, Minnekahta Limestone, Minnelusa Formation, Madison Limestone, and Deadwood Formation in the Black Hills Area, South Dakota

Open-File Report 99-260

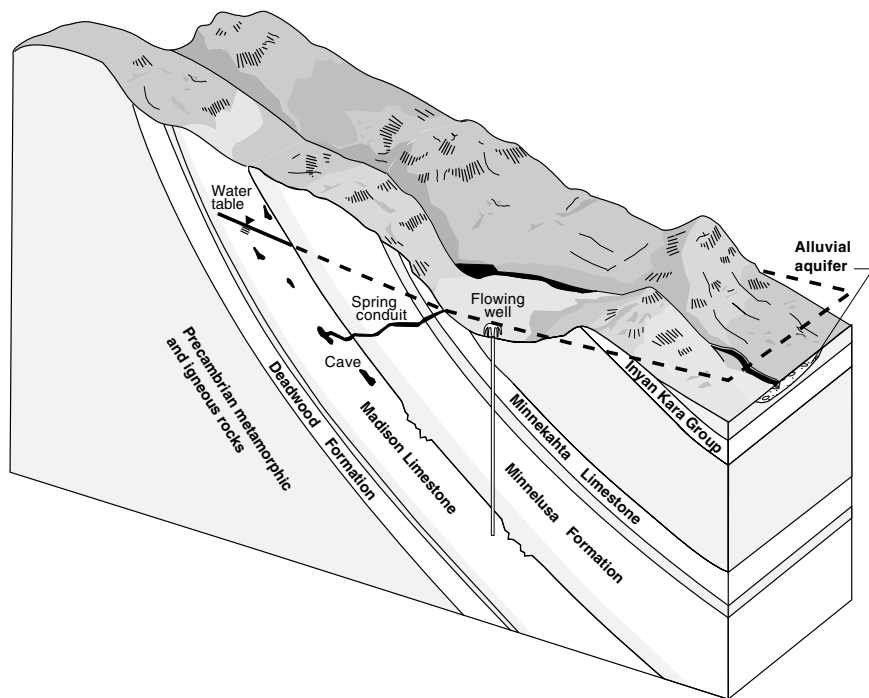

Report Documentation Page

Form Approved
OMB No. 0704-0188

Public reporting burden for the collection of information is estimated to average 1 hour per response, including the time for reviewing instructions, searching existing data sources, gathering and maintaining the data needed, and completing and reviewing the collection of information. Send comments regarding this burden estimate or any other aspect of this collection of information, including suggestions for reducing this burden, to Washington Headquarters Services, Directorate for Information Operations and Reports, 1215 Jefferson Davis Highway, Suite 1204, Arlington VA 22202-4302. Respondents should be aware that notwithstanding any other provision of law, no person shall be subject to a penalty for failing to comply with a collection of information if it does not display a currently valid OMB control number.

1. REPORT DATE 1999		2. REPORT TYPE N/A		3. DATES COVERED -	
4. TITLE AND SUBTITLE Selected Data for Wells and Test Holes Used in Structure-Contour Maps of the Inyan Kara Group, Minnekahta Limestone, Minnelusa Formation, Madison Limestone, and Deadwood Formation in the Black Hills Area, South Dakota				5a. CONTRACT NUMBER	
				5b. GRANT NUMBER	
				5c. PROGRAM ELEMENT NUMBER	
6. AUTHOR(S)				5d. PROJECT NUMBER	
				5e. TASK NUMBER	
				5f. WORK UNIT NUMBER	
7. PERFORMING ORGANIZATION NAME(S) AND ADDRESS(ES) U.S. Department of the Interior 1849 C Street, NW Washington, DC 20240				8. PERFORMING ORGANIZATION REPORT NUMBER	
9. SPONSORING/MONITORING AGENCY NAME(S) AND ADDRESS(ES)				10. SPONSOR/MONITOR'S ACRONYM(S)	
				11. SPONSOR/MONITOR'S REPORT NUMBER(S)	
12. DISTRIBUTION/AVAILABILITY STATEMENT Approved for public release, distribution unlimited					
13. SUPPLEMENTARY NOTES The original document contains color images.					
14. ABSTRACT					
15. SUBJECT TERMS					
16. SECURITY CLASSIFICATION OF:			17. LIMITATION OF ABSTRACT SAR	18. NUMBER OF PAGES 57	19a. NAME OF RESPONSIBLE PERSON
a. REPORT unclassified	b. ABSTRACT unclassified	c. THIS PAGE unclassified			

U.S. Department of the Interior
U.S. Geological Survey

Selected Data for Wells and Test Holes Used in Structure-Contour Maps of the Inyan Kara Group, Minnekahta Limestone, Minnelusa Formation, Madison Limestone, and Deadwood Formation in the Black Hills Area, South Dakota

By Janet M. Carter

Open-File Report 99-260

Prepared in cooperation with the
South Dakota Department of Environment and Natural Resources
and the West Dakota Water Development District

U.S. Department of the Interior

Bruce Babbitt, Secretary

U.S. Geological Survey

Charles G. Groat, Director

The use of firm, trade, and brand names in this report is for identification purposes only and does not constitute endorsement by the U.S. Geological Survey.

Rapid City, South Dakota: 1999

For additional information write to:

**District Chief
U.S. Geological Survey
1608 Mt. View Road
Rapid City, SD 57702**

Copies of this report can be purchased from:

**U.S. Geological Survey
Information Services
Box 25286
Denver, CO 80225-0286**

CONTENTS

Abstract..... 1
Introduction 1
Methods of Station Identification 4
Well and Test-Hole Data..... 6
References 6

ILLUSTRATIONS

1. Map showing area of investigation for the Black Hills Hydrology Study 2
2. Stratigraphic section for the Black Hills 3
3. Schematic showing simplified hydrogeologic setting of the Black Hills area 4
4. Diagram showing system for assignment of local numbers 5

TABLES

1. Selected data for wells and test holes used in the structure-contour map of the Inyan Kara Group..... 9
2. Selected data for wells and test holes used in the structure-contour map of the Minnekahta Limestone..... 18
3. Selected data for wells and test holes used in the structure-contour map of the Minnelusa Formation 30
4. Selected data for wells and test holes used in the structure-contour map of the Madison Limestone..... 45
5. Selected data for wells and test holes used in the structure-contour map of the Deadwood Formation..... 50

Selected Data for Wells and Test Holes Used in Structure-Contour Maps of the Inyan Kara Group, Minnekahta Limestone, Minnelusa Formation, Madison Limestone, and Deadwood Formation in the Black Hills Area, South Dakota

By Janet M. Carter

ABSTRACT

This report presents selected data on wells and test holes that were used in the construction of structure-contour maps of selected formations that contain major aquifers in the Black Hills area of western South Dakota. Altitudes of the top of the Inyan Kara Group, Minnekahta Limestone, Minnelusa Formation, Madison Limestone, and Deadwood Formation are presented for the wells and test holes presented in this report.

INTRODUCTION

The Black Hills Hydrology Study was initiated in 1990 to assess the quantity, quality, and distribution of surface water and ground water in the Black Hills area of South Dakota (Driscoll, 1992). This long-term study is a cooperative effort between the U.S. Geological Survey (USGS), the South Dakota Department of Environment and Natural Resources, and the West Dakota Water Development District, which represents various local and county cooperators.

The study area (fig. 1) consists of the topographically defined Black Hills and adjacent areas located in western South Dakota. The Black Hills area is an elongated, dome-shaped feature, about 125 miles long and 60 miles wide, which was uplifted during the Laramide orogeny (Feldman and Heimlich, 1980). The oldest geologic units in the study area are Precambrian metamorphic and igneous rocks (fig. 2), which are

exposed in the central core of the Black Hills. Surrounding the Precambrian core is a layered series of sedimentary rocks including limestones, sandstones, and shales that are exposed in roughly concentric rings around the uplifted flanks of the Black Hills. The bedrock sedimentary units typically dip away from the uplifted Black Hills at angles that approach or exceed 10 degrees near the outcrops, and decrease with distance from the uplift. Many of the sedimentary units contain aquifers, both within and beyond the study area. Major aquifers in the study area include the Inyan Kara, Minnekahta, Minnelusa, Madison, and Deadwood aquifers (fig. 3). Recharge to these aquifers occurs from infiltration of precipitation upon the outcrops and, in some cases, from infiltration of streamflow (Hortness and Driscoll, 1998). Artesian conditions generally exist within these aquifers, where an upper confining layer is present. Flowing wells and artesian springs that originate from confined aquifers are common around the periphery of the Black Hills.

The purpose of this report is to present selected data for wells and test holes that were used in the construction of maps showing the altitude of the tops of selected formations (structure contours) within the study area. The structure-contour maps presented by Carter and Redden (1999a, 1999b, 1999c, 1999d, 1999e) were produced at a scale of 1:100,000 for the Inyan Kara Group, Minnekahta Limestone, Minnelusa Formation, Madison Limestone, and the Deadwood Formation. Altitudes of the top of these formations are presented for the wells and test holes in this report.

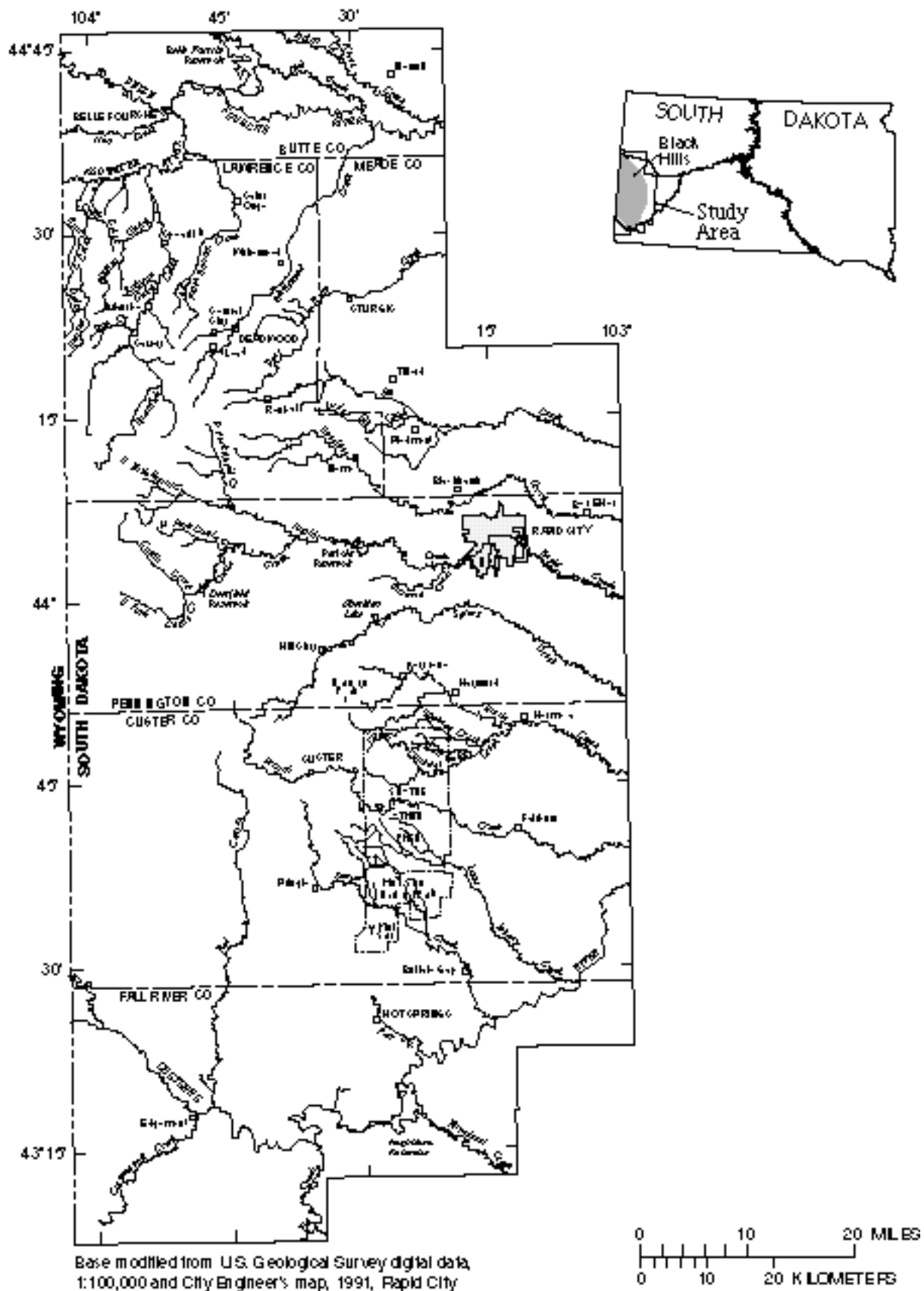

Figure 1. Area of investigation for the Black Hills Hydrology Study.

ERA/PERIOD	SYSTEM	AGE REVISION FOR STRATIGRAPHIC INTERVAL	GEOLOGIC UNIT	THICKNESS IN FEET	DESCRIPTION	
CENOZOIC	QUATERNARY & TERTIARY (CENOZOIC TERTIARY)	Tm	MISSOURI RIVER GROUP	500 500-550	Gravelly sandstone, siltstone, and claystone. Some shaly sandstone.	
			NEBRASKA GROUP	1,000-2,000	Shaly sandstone, siltstone, and claystone. Some shaly sandstone.	
MESOZOIC	CRETACEOUS	K	NEBRASKA GROUP	5,000-10,000	Gravelly sandstone, siltstone, and claystone. Some shaly sandstone.	
			NEBRASKA GROUP	5,000-10,000	Gravelly sandstone, siltstone, and claystone. Some shaly sandstone.	
			NEBRASKA GROUP	5,000-10,000	Gravelly sandstone, siltstone, and claystone. Some shaly sandstone.	
			NEBRASKA GROUP	5,000-10,000	Gravelly sandstone, siltstone, and claystone. Some shaly sandstone.	
			NEBRASKA GROUP	5,000-10,000	Gravelly sandstone, siltstone, and claystone. Some shaly sandstone.	
			NEBRASKA GROUP	5,000-10,000	Gravelly sandstone, siltstone, and claystone. Some shaly sandstone.	
			NEBRASKA GROUP	5,000-10,000	Gravelly sandstone, siltstone, and claystone. Some shaly sandstone.	
			NEBRASKA GROUP	5,000-10,000	Gravelly sandstone, siltstone, and claystone. Some shaly sandstone.	
			NEBRASKA GROUP	5,000-10,000	Gravelly sandstone, siltstone, and claystone. Some shaly sandstone.	
			NEBRASKA GROUP	5,000-10,000	Gravelly sandstone, siltstone, and claystone. Some shaly sandstone.	
			NEBRASKA GROUP	5,000-10,000	Gravelly sandstone, siltstone, and claystone. Some shaly sandstone.	
			NEBRASKA GROUP	5,000-10,000	Gravelly sandstone, siltstone, and claystone. Some shaly sandstone.	
PALEOZOIC	JURASSIC	J	NEBRASKA GROUP	5,000-10,000	Gravelly sandstone, siltstone, and claystone. Some shaly sandstone.	
			NEBRASKA GROUP	5,000-10,000	Gravelly sandstone, siltstone, and claystone. Some shaly sandstone.	
			NEBRASKA GROUP	5,000-10,000	Gravelly sandstone, siltstone, and claystone. Some shaly sandstone.	
	TRIASIC	T	T	NEBRASKA GROUP	5,000-10,000	Gravelly sandstone, siltstone, and claystone. Some shaly sandstone.
				NEBRASKA GROUP	5,000-10,000	Gravelly sandstone, siltstone, and claystone. Some shaly sandstone.
	PERMIAN	P	P	NEBRASKA GROUP	5,000-10,000	Gravelly sandstone, siltstone, and claystone. Some shaly sandstone.
				NEBRASKA GROUP	5,000-10,000	Gravelly sandstone, siltstone, and claystone. Some shaly sandstone.
				NEBRASKA GROUP	5,000-10,000	Gravelly sandstone, siltstone, and claystone. Some shaly sandstone.
	PENNSYLVANIAN	P	P	NEBRASKA GROUP	5,000-10,000	Gravelly sandstone, siltstone, and claystone. Some shaly sandstone.
				NEBRASKA GROUP	5,000-10,000	Gravelly sandstone, siltstone, and claystone. Some shaly sandstone.
				NEBRASKA GROUP	5,000-10,000	Gravelly sandstone, siltstone, and claystone. Some shaly sandstone.
	DEVONIAN	D	D	NEBRASKA GROUP	5,000-10,000	Gravelly sandstone, siltstone, and claystone. Some shaly sandstone.
NEBRASKA GROUP				5,000-10,000	Gravelly sandstone, siltstone, and claystone. Some shaly sandstone.	
NEBRASKA GROUP				5,000-10,000	Gravelly sandstone, siltstone, and claystone. Some shaly sandstone.	
ORDOVICIAN	O	O	NEBRASKA GROUP	5,000-10,000	Gravelly sandstone, siltstone, and claystone. Some shaly sandstone.	
			NEBRASKA GROUP	5,000-10,000	Gravelly sandstone, siltstone, and claystone. Some shaly sandstone.	
			NEBRASKA GROUP	5,000-10,000	Gravelly sandstone, siltstone, and claystone. Some shaly sandstone.	
CAMBRIAN	C	C	NEBRASKA GROUP	5,000-10,000	Gravelly sandstone, siltstone, and claystone. Some shaly sandstone.	
			NEBRASKA GROUP	5,000-10,000	Gravelly sandstone, siltstone, and claystone. Some shaly sandstone.	
			NEBRASKA GROUP	5,000-10,000	Gravelly sandstone, siltstone, and claystone. Some shaly sandstone.	
PRE-CAMBRIAN	P	P	NEBRASKA GROUP	5,000-10,000	Gravelly sandstone, siltstone, and claystone. Some shaly sandstone.	
			NEBRASKA GROUP	5,000-10,000	Gravelly sandstone, siltstone, and claystone. Some shaly sandstone.	
			NEBRASKA GROUP	5,000-10,000	Gravelly sandstone, siltstone, and claystone. Some shaly sandstone.	

Figure 2. Stratigraphic section for the Black Hills. Modified from information furnished by the Department of Geology and Geological Engineering, South Dakota School of Mines and Technology (written commun., January 1994).

Figure 2. Stratigraphic section for the Black Hills.

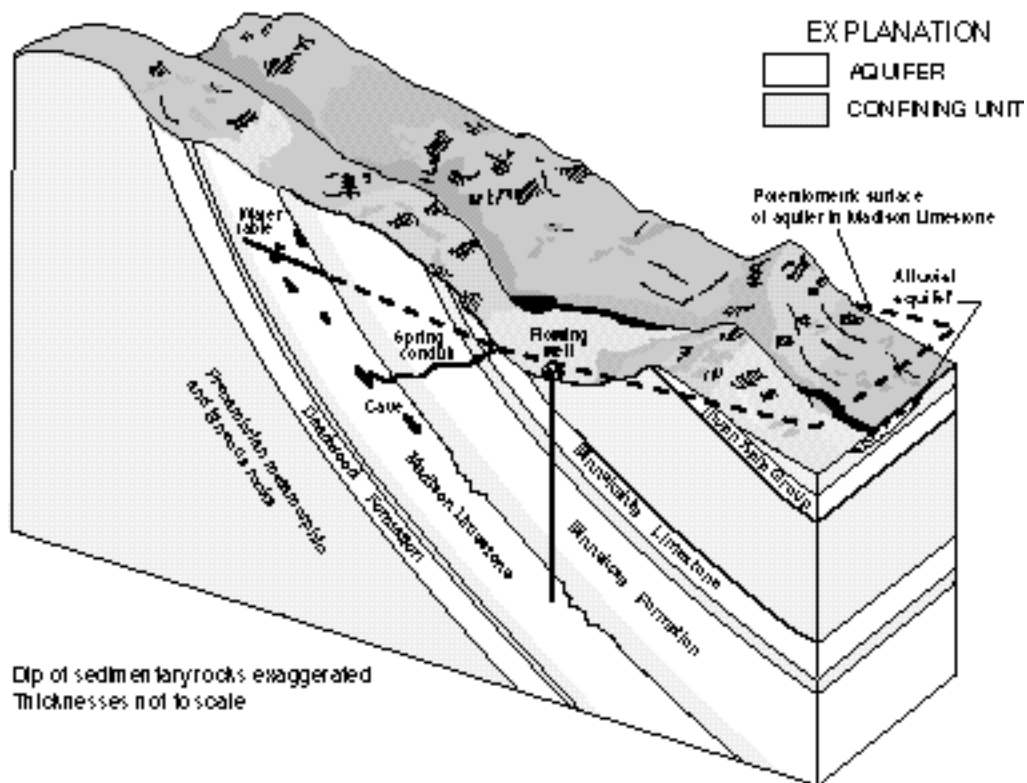

Figure 3. Schematic showing simplified hydrogeologic setting of the Black Hills area.

METHODS OF STATION IDENTIFICATION

Two methods of station identification are used within this report to identify sites for which data are presented. The first method is the local number, which is based on the Federal land-survey system for western South Dakota (fig. 4). The local number consists of the township number followed by “N” or “S” (north or south of the Black Hills Baseline), the range number followed by “E” or “W” (east or west of the Black Hills Meridian), and the section number, followed by a maximum of four uppercase letters that indicate, respectively, the 160-, 40-, 10-, and 2.5-acre tract in which the site is located. These letters are assigned in a counterclockwise direction beginning with “A” for the northeast quarter. A serial number following the last letter is used to distinguish between wells located in the same 2.5 acre-tract. Thus, well 4N6E19AABA (fig. 4) is in the NE1/4 of the NW1/4 of the NE1/4 of the NE1/4 of section 19 in township 4 north and range 6 east.

The second method is the station identification number, which is based on the international system of latitude and longitude. The number contains 15 digits. The first six digits denote the degrees, minutes, and seconds of latitude north of the equator. The next seven digits denote the degrees, minutes, and seconds of longitude west of the prime (Greenwich) meridian. In cases where the latitude and longitude were determined to the tenths of degrees, the latitudes and longitudes were rounded to the nearest second in the corresponding station identification number. The last two digits are sequential numbers for sites located at the same latitude and longitude. The latitudes or longitudes originally assigned to sites occasionally are determined to be incorrect. In these cases, the latitude or longitude is corrected, but the station identification number remains unchanged. Thus, the latitude or longitude may not correspond exactly with the station identification number.

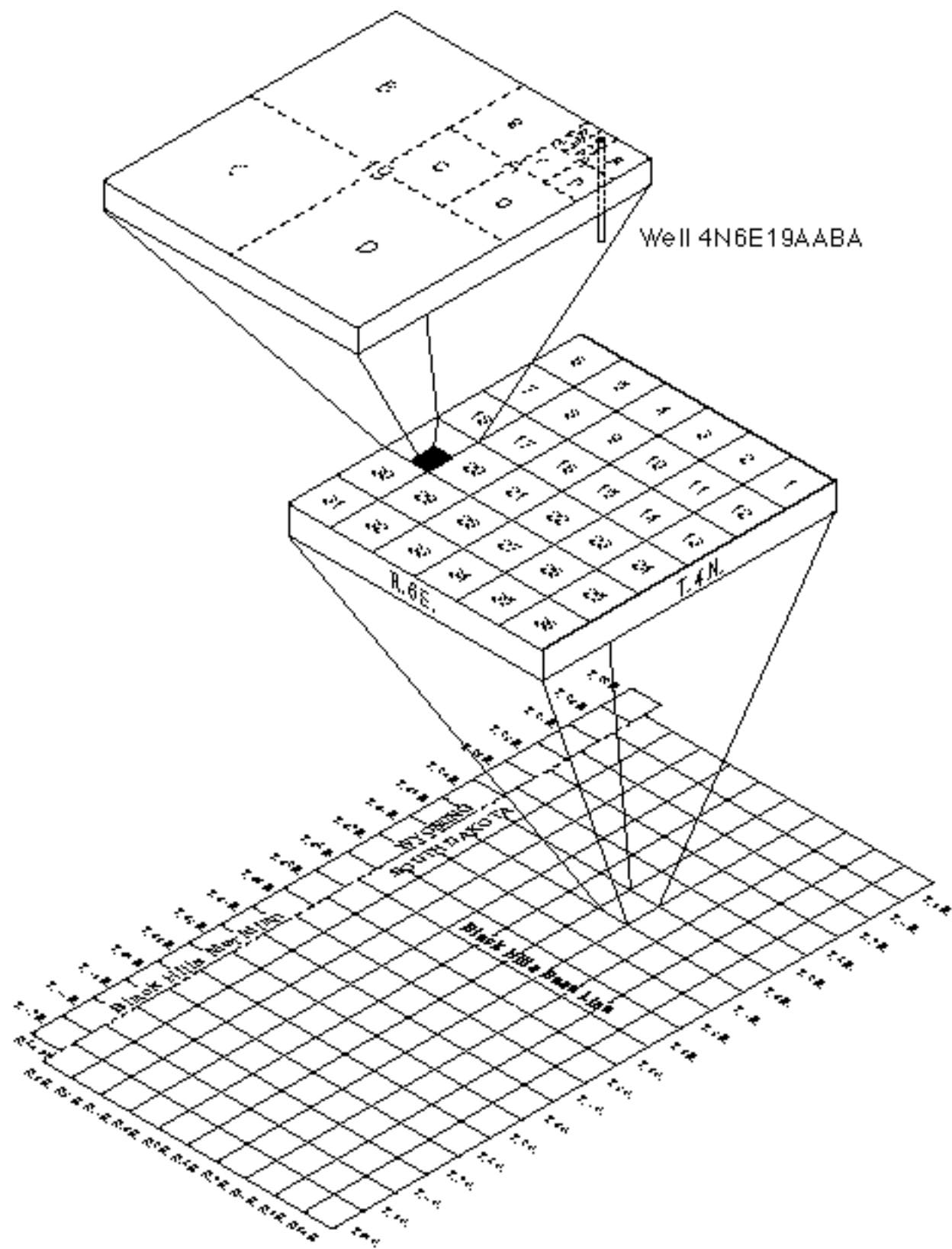

Figure 4. System for assignment of local numbers.

WELL AND TEST-HOLE DATA

Selected data are presented for wells and test holes used in the construction of structure-contour maps of the Inyan Kara Group (table 1), Minnekahta Limestone (table 2), Minnelusa Formation (table 3), Madison Limestone (table 4), and the Deadwood Formation (table 5). Wells and test holes that penetrated more than one of these formations are listed in multiple tables. The wells and test holes presented in tables 1-5 are identified by the methods previously described. The wells and test holes are shown on maps presented by Carter and Redden (1999a, 1999b, 1999c, 1999d, 1999e). The altitudes of the tops of the formations were compiled from data obtained from J. Paul Gries (South Dakota School of Mines and Technology), the South Dakota Geological Survey, and the USGS.

REFERENCES

- Carter, J.M., and Redden, J.A., 1999a, Altitude of the top of the Inyan Kara Group in the Black Hills area, South Dakota: U.S. Geological Survey Hydrologic Investigations Atlas HA-744-A, 2 sheets, scale 1:100,000.
- 1999b, Altitude of the top of the Minnekahta Limestone in the Black Hills area, South Dakota: U.S. Geological Survey Hydrologic Investigations Atlas HA-744-B, 2 sheets, scale 1:100,000.
- 1999c, Altitude of the top of the Minnelusa Formation in the Black Hills area, South Dakota: U.S. Geological Survey Hydrologic Investigations Atlas HA-744-C, 2 sheets, scale 1:100,000.
- 1999d, Altitude of the top of the Madison Limestone in the Black Hills area, South Dakota: U.S. Geological Survey Hydrologic Investigations Atlas HA-744-D, 2 sheets, scale 1:100,000.
- 1999e, Altitude of the top of the Deadwood Formation in the Black Hills area, South Dakota: U.S. Geological Survey Hydrologic Investigations Atlas HA-744-E, 2 sheets, scale 1:100,000.
- Driscoll, D.G., 1992, Plan of study for the Black Hills Hydrology Study, South Dakota: U.S. Geological Survey Open-File Report 92-84, 10 p.
- Feldman, R.M., and Heimlich, R.A., 1980, The Black Hills: K/H Geology Field Guide Series, Kendall/Hunt Publishing Company, Kent State University, Kent, Ohio, 190 p.
- Hortness, J.E., and Driscoll, D.G., 1998, Streamflow losses in the Black Hills of western South Dakota: U.S. Geological Survey Water-Resources Investigations Report 98-4116, 99 p.

TABLES

Table 1. Selected data for wells and test holes used in the structure-contour map of the Inyan Kara Group

[NGVD29, National Geodetic Vertical Datum of 1929; W, well; X, test hole; --, no data]

USGS local number	Station identification number	Latitude	Longitude	Date of construction	Type of site	Depth of hole, in feet below land surface	Altitude, in feet above NGVD29	
		(degrees, minutes, seconds)					Land surface	Top of the Inyan Kara Group ¹
Butte County								
9N 6E36DA	444147103193501	444147	1031935	10/09/1976	W	5,575	2,804	354
9N 6E30ACCC	444249103260701	444249	1032607	07/25/1964	W	2,745	2,850	447
9N 6E30AAD	444301103253501	444301	1032535	--/--/1940	W	2,741	2,850	400
9N 5E24ACA	444350103270701	444350	1032704	07/12/1934	W	4,400	2,860	460
9N 4E19CADA	444332103405301	444332	1034047	10/--/1906	W	1,417	2,999	1,620
9N 3E27ADBD	444253103440001	444253	1034359	07/--/1952	W	4,016	3,002	2,352
9N 2E34CDDCA	444129103514801	444129	1035148	10/10/1981	W	3,320	3,185	2,317
9N 2E34ADBC	444200103511401	444200	1035114	--/--/1955	W	1,320	3,075	2,419
9N 2E33CCD	444102103525301	444131	1035318	02/12/1980	W	1,250	3,020	2,365
9N 2E32DBBA	444153103540001	444153	1035400	--/--/1947	W	1,020	3,050	2,350
9N 2E30CDBC	444227103553801	444227	1035538	08/12/1972	W	780	3,130	2,660
9N 2E 5CBBC	444609103544301	444609	1035443	--/--/1956	W	1,625	3,150	1,785
9N 1E27BDAB	444248103590901	444248	1035909	--/--/1958	W	480	3,160	2,810
9N 1E26BCBC	444301103581401	444301	1035814	--/--/1958	W	563	3,070	2,729
9N 1E21CABB	444347104003101	444337	1040032	04/28/1953	W	950	3,175	2,920
8N 5E32DDD	443618103314301	443618	1033143	05/18/1979	W	1,650	3,020	1,648
8N 5E12DBC	444002103272001	444002	1032720	12/13/1949	W	5,759	2,880	700
8N 5E 8BCB2	444020103323001	444020	1033230	--/--/1938	W	2,050	2,855	1,203
8N 4E17AAAB	443944103385901	443944	1033859	03/02/1964	W	1,070	2,895	2,094
8N 4E10DDDB	443953103363601	443953	1033636	--/--/1960	W	1,180	2,870	1,817
8N 4E 9DDBA	443958103375101	443958	1033751	01/03/1972	W	1,170	2,880	2,030
8N 4E 8DB	444006103391901	444006	1033919	09/12/1973	W	930	2,940	2,120
8N 3E31BBAA	443709103481501	443709	1034815	--	W	310	3,165	2,935
8N 3E31ACA	443655103482001	443650	1034744	08/21/1960	W	1,853	3,190	3,007
8N 3E 7BBCB	444022103482601	444022	1034826	11/--/1957	W	860	3,115	2,340
8N 3E 6CCA	444048103481701	444048	1034817	09/26/1951	W	886	3,075	2,305
8N 3E 5BDCD	444109103465401	444109	1034654	09/--/1955	W	1,237	3,040	2,080
8N 3E 5BABB	444129103465801	444129	1034658	04/29/1965	W	1,020	3,010	2,060
8N 3E 2DB	444057103425701	444057	1034257	07/25/1960	W	2,240	2,990	2,495
8N 2E30BB	443756103553601	443756	1035536	11/07/1980	W	180	3,240	3,200
8N 2E29ACAC	443744103535001	443744	1035350	04/24/1964	W	200	3,280	3,190
8N 2E29AAA	443805103532601	443757	1035333	07/01/1980	W	240	3,220	3,190
8N 2E28DDCB	443716103522501	443716	1035225	03/11/1980	W	2,220	3,242	3,142

Table 1. Selected data for wells and test holes used in the structure-contour map of the Inyan Kara Group—Continued

[NGVD29, National Geodetic Vertical Datum of 1929; W, well; X, test hole; --, no data]

USGS local number	Station identification number	Latitude	Longitude	Date of construction	Type of site	Depth of hole, in feet below land surface	Altitude, in feet above NGVD29		
		(degrees, minutes, seconds)					Land surface	Top of the Inyan Kara Group ¹	
Butte County—Continued									
8N 2E28BADD2	443731103525601	443750	1035250	02/25/1948	W	240	3,220	3,143	
8N 2E23DCCA	443806103501301	443806	1035013	04/21/1975	W	260	3,160	3,107	
8N 2E23CACB	443820103503701	443820	1035037	07/--/1990	W	240	3,140	3,095	
8N 2E22CACA	443823103514301	443823	1035143	--	W	369	3,170	2,884	
8N 2E22AAC	443812103511301	443843	1035113	07/14/1975	W	260	3,170	2,910	
8N 2E21CDBC	443810103525601	443810	1035256	12/15/1975	W	340	3,220	3,060	
8N 2E20CCD	443806103542101	443806	1035421	07/02/1980	W	420	3,240	3,100	
8N 2E20BACC	443842103541801	443842	1035418	--/--/1956	W	300	3,145	3,080	
8N 2E19DBBD	443824103550501	443824	1035505	07/20/1991	W	100	3,160	3,140	
8N 2E19C	443814103552101	443814	1035521	11/07/1980	W	190	3,185	3,145	
8N 2E19AD	443857103540901	443834	1035448	09/05/1979	W	300	3,165	3,085	
8N 2E16DDD	443855103521501	443855	1035215	07/06/1978	W	400	3,175	2,857	
8N 2E16BBDD	443934103530501	443934	1035305	06/20/1973	W	300	3,160	2,955	
8N 2E16ACA	443954103520601	443929	1035236	03/21/1979	W	340	3,080	2,834	
8N 2E16AACC	443934103522801	443934	1035228	12/15/1973	W	520	3,150	2,800	
8N 2E14DC	443905103501201	443905	1035012	02/18/1977	W	430	3,090	2,890	
8N 2E14ACBB	443855103493001	443933	1034959	09/05/1982	W	455	3,050	2,670	
8N 2E12DDC	443950103484301	443950	1034843	09/17/1979	W	820	3,130	2,560	
8N 2E11DDBD	443954103495301	443954	1034953	08/25/1973	W	440	3,033	2,663	
8N 2E11DC3	443952103501203	443952	1035012	--/--/1957	W	570	3,035	2,745	
8N 2E11CDBD	443954103503001	443954	1035030	08/18/1947	W	353	3,070	2,747	
8N 2E11BABD	444033103503001	444033	1035030	--	W	650	3,005	2,655	
8N 2E10CDCB	443950103515001	443950	1035150	03/15/1982	W	500	3,135	2,715	
8N 2E10BDDD2	444013103513402	444013	1035134	--	W	470	3,000	2,700	
8N 2E 3DAAD	444058103505801	444058	1035058	08/31/1979	W	705	3,090	2,630	
8N 2E 3AD	444110103510701	444110	1035107	08/31/1979	W	705	3,091	2,446	
8N 2E 2BBBB	444129103505501	444129	1035055	09/25/1973	W	760	3,049	2,443	
8N 1E12BB	444032103565301	444027	1035643	10/14/1982	W	280	3,220	3,060	
8N 1E11BA	444033103574801	444033	1035748	--	W	520	3,300	3,075	
Lawrence County									
7N 4E25ADBB	443230103342001	443230	1033420	04/15/1989	W	1,020	3,187	2,562	
7N 4E17CCAA	443347103395801	443342	1033951	07/26/1974	W	440	3,300	2,900	
7N 4E11ADDB	443503103352001	443503	1033520	02/23/1989	W	780	3,112	2,354	

Table 1. Selected data for wells and test holes used in the structure-contour map of the Inyan Kara Group—Continued

[NGVD29, National Geodetic Vertical Datum of 1929; W, well; X, test hole; --, no data]

USGS local number	Station identification number	Latitude	Longitude	Date of construction	Type of site	Depth of hole, in feet below land surface	Altitude, in feet above NGVD29	
		(degrees, minutes, seconds)					Land surface	Top of the Inyan Kara Group ¹
Lawrence County—Continued								
7N 4E 7CDCA	443451103403801	443435	1034053	07/23/1974	W	365	3,320	3,120
7N 4E 2BDAC	443557103360401	443558	1033559	12/08/1976	W	757	3,050	2,325
7N 3E26ADBB	443257103422001	443235	1034246	08/21/1985	W	380	3,460	3,150
7N 3E25ADBD	443338103413301	443231	1034128	--/--/1959	W	510	3,500	3,410
7N 3E23BBCC2	443327103425701	443327	1034343	04/24/1981	W	260	3,390	3,210
7N 3E22DAAD	443306103434001	443310.8	1034347.2	12/10/1990	W	390	3,409.0	3,195
7N 3E22BBCD	433331103444701	443331	1034447	--/--/1959	W	403	3,390	3,373
7N 3E16AAB	443429103450001	443432	1034507	05/15/1965	W	490	3,330	3,108
7N 3E 9DBBD	443454103452701	443454	1034527	--/--/1963	W	450	3,300	3,063
6N 4E 2CDCB	443022103361101	443016	1033612	06/13/1979	W	240	3,390	3,382
Meade County								
7N 6E25BC	443228103203701	443228	1032037	04/25/1961	W	2,147	2,894	844
7N 5E29BBD	443237103323801	443237	1033238	07/31/1925	W	790	3,140	2,465
7N 5E28BB	443244103313101	443244	1033131	07/31/1973	W	1,000	3,090	2,370
6N 6E 7BAB	443010103263701	443010	1032637	12/12/1985	W	1,563	3,100	1,980
6N 5E21DAB	442758103304401	442758	1033044	09/25/1988	W	510	3,240	2,940
6N 5E17BCCC	442854103325201	442854	1033252	07/10/1979	W	580	3,275	3,182
6N 5E17BBAD	442913103315001	442913	1033238	02/11/1955	W	370	3,240	3,061
6N 5E16CDCC	442828103312001	442827.8	1033123.2	05/24/1989	W	482	3,274.4	2,978
5N 6E33CDDA	442029103234801	442044	1032356	07/22/1976	W	525	3,425	3,200
5N 6E25ABBB	442214103200401	442222	1032014	--/--/1955	W	816	3,040	2,359
5N 6E18BAAA	442355103255201	442403	1032618	10/06/1967	W	465	3,270	3,060
5N 6E17BAC	442359103251901	442359	1032519	05/08/1992	W	640	3,220	2,630
4N 9E19AD	441741103042201	441741	1030422	11/20/1956	W	2,600	3,159	650
4N 8E31BD	441557103121301	441557	1031213	02/23/1956	W	1,506	3,057	1,585
4N 8E27BB	441702103085501	441702	1030855	02/09/1956	W	2,034	3,034	1,024
4N 8E11AA	441940103064501	441940	1030645	10/21/1956	W	2,214	2,838	705
4N 8E 2ADDC	442009103135501	442009	1030715	09/--/1961	W	2,389	2,815	687
4N 7E17DAAA	441816103102001	441824	1031736	08/17/1960	W	1,120	3,120	2,325
4N 7E 5CC	441953103183501	441953	1031835	01/27/1956	W	869	3,177	2,342
4N 6E25ACAB	441834103232501	441655	1032020	06/19/1978	W	360	3,240	3,060
4N 6E13BBBC	441820103205801	441850	1032105	05/23/1953	W	795	3,220	2,770
4N 6E11CDBA	441859103215301	441903	1032153	--/--/1969	W	415	3,245	2,927

Table 1. Selected data for wells and test holes used in the structure-contour map of the Inyan Kara Group—Continued

[NGVD29, National Geodetic Vertical Datum of 1929; W, well; X, test hole; --, no data]

USGS local number	Station identification number	Latitude	Longitude	Date of construction	Type of site	Depth of hole, in feet below land surface	Altitude, in feet above NGVD29	
		(degrees, minutes, seconds)					Land surface	Top of the Inyan Kara Group ¹
Meade County—Continued								
4N 6E11CACC	441918103214301	441908	1032201	11/--/1969	W	688	3,258	2,946
4N 6E11CAAA	441938103215301	441916	1032145	--/--/1969	W	423	3,260	2,943
4N 6E10ABAB	441918103225601	441945	1032242	08/03/1959	W	544	3,305	3,010
3N 8E32BDCB2	441042103110201	441039	1031107	--	W	1,624	3,185	1,877
3N 8E25BA	441147103061101	441147	1030611	08/24/1974	W	2,250	2,990	960
3N 8E24CB	441214103062801	441214	1030628	10/09/1956	W	2,032	2,945	985
3N 8E21DAAD	441219103090801	441222	1030904	--/--/1960	W	1,998	3,025	1,345
3N 8E14BB	441332103074001	441332	1030740	09/30/1956	W	1,945	2,933	1,083
2N 9E18BAB	440824103050601	440824	1030506	04/17/1942	W	4,645	3,195	1,059
2N 9E 9BBB2	440913103025601	440913	1030256	08/30/1950	W	2,408	3,180	800
2N 9E 8CDC	440828103035101	440828	1030351	09/12/1990	W	2,488	3,160	920
2N 9E 7CABC	440844103050601	440844	1030506	08/12/1943	W	2,506	3,193.66	1,043
2N 8E13BDC	440801103061601	440801	1030616	07/12/1942	W	4,440	3,199	1,094
2N 8E 6CCDB	440920103265401	440920	1031232	06/07/1979	W	1,880	3,520	1,908
2N 7E 2DBDDC	440931103141401	440931	1031414	04/23/1980	W	3,060	3,383	3,003
2N 7E 1CA	440931103131701	440931	1031317	11/--/1961	W	1,230	3,285	2,395
Pennington County								
2N 9E30DB	440607103044101	440607	1030441	--	W	2,161	3,090	1,002
2N 9E29BCC	440629103040901	440629	1030409	03/18/1983	W	4,450	3,043	983
2N 9E18BDDC	440759103045501	440759	1030500	10/04/1951	W	2,435	3,172	1,027
2N 8E28BCB	440622103101101	440622	1031011	06/25/1973	W	1,648	3,128	1,528
2N 8E27CBAC	440606103085301	440606	1030853	07/12/1973	W	1,798	3,150	1,495
2N 8E23DA	440659103064701	440659	1030650	07/18/1965	W	2,222	3,067.5	1,180
2N 8E20CCCD	440650103110001	440641	1031120	08/09/1973	W	1,625	3,170	1,650
2N 8E14ADD	440801103064301	440801	1030747	--	W	2,088	3,203	1,133
2N 7E35DABD	440517103140501	440517	1031405	06/25/1990	W	49	3,235	3,229
2N 7E23DDA	440650103135701	440650	1031357	02/17/1993	W	540	3,420	3,285
2N 7E13DDAA	440746103124201	440746.0	1031241.8	10/27/1995	W	1,450	3,238.9	2,158
1N 9E34CB	440007103014201	440007	1030142	01/11/1957	W	2,229	2,945	806
1N 9E22BA	440212103012101	440212	1030121	07/15/1952	W	4,185	3,052	737
1N 9E 5DD	440409103030801	440409	1030308	12/18/1956	W	2,404	3,284	959
1N 8E34ABAD	440029103081101	440029	1030811	06/18/1995	W	1,600	3,120	1,835
1N 8E32ABBA	440006103105101	440032	1031051	--/--/1954	W	1,100	3,325	2,667

Table 1. Selected data for wells and test holes used in the structure-contour map of the Inyan Kara Group—Continued

[NGVD29, National Geodetic Vertical Datum of 1929; W, well; X, test hole; --, no data]

USGS local number	Station identification number	Latitude	Longitude	Date of construction	Type of site	Depth of hole, in feet below land surface	Altitude, in feet above NGVD29	
		(degrees, minutes, seconds)					Land surface	Top of the Inyan Kara Group ¹
Pennington County—Continued								
1N 8E19AAAB	440216103114101	440215.6	1031141.4	03/25/1996	W	600	3,249.7	2,714
1N 8E 9CAB2	440334103095601	440334	1030956	09/--/1990	W	3,805	3,108	2,012
1N 8E 5DACB	440422103103301	440422	1031033	02/--/1957	W	971	3,165	2,250
2S 9E15BB	435252103021101	435252	1030211	--	W	2,170	3,073	956
Custer County								
2S 8E32CCC	434935103122001	434935	1031150	10/21/1980	W	820	3,300	2,638
2S 8E33DC	434937103095701	434937	1030957	03/13/1956	W	961	3,247	2,306
2S 9E35AA	435016103000501	435016	1030005	08/22/1955	W	2,602	3,091	796
3S 8E19BBBB	434652103130501	434653.7	1031307.2	06/28/1983	W	760	3,506.8	2,920
3S 8E22ACDB	434633103084401	434633	1030844	08/16/1959	W	1,956	3,393.78	1,766
3S 8E24DC	434608103062301	434608	1030623	03/20/1956	W	1,544	3,208	1,703
4S 7E25DDDB	434001103131301	434001	1031313	07/04/1949	W	2,824	3,392	2,702
4S 8E12AA	434316103061101	434316	1030611	10/25/1980	W	3,773	3,158	1,171
4S 8E21BA2	434134103101501	434134	1031015	10/03/1957	W	1,605	3,425	1,885
6S 1E20AA	433109104011501	433109	1040105	08/17/1981	W	580	3,760	3,340
6S 1E20AB	433111104012201	433111	1040122	08/18/1981	W	800	3,730	3,300
6S 1E20AC	433038104015201	433057	1040122	08/15/1981	W	810	3,765	3,260
6S 1E20AD	433100104010201	433100	1040102	08/14/1981	W	800	3,815	3,390
6S 1E29ABC	433012104012701	433012	1040127	06/27/1978	W	680	3,700	3,095
6S 1E29ABC2	433012104012702	433012	1040127	06/26/1978	W	1,000	3,700	3,080
6S 7E29CCD	432932103190701	432932	1031907	--/--/1956	W	1,240	3,300	2,214
6S 8E24CC	433028103071801	433028	1030718	10/19/1955	W	2,882	3,030	465
Fall River County								
7S 1E 3BB	432855103593901	432838	1035939	10/22/1980	W	625	3,655	3,335
7S 1E10DC	432705103585801	432705	1035858	11/07/1978	W	550	3,620	3,370
7S 1E10DC2	432705103585802	432705	1035858	11/07/1978	W	360	3,620	3,370
7S 1E14B2	432641103581301	432641	1035813	06/--/1956	W	237	3,670	3,650
7S 1E15AB	432647103585901	432647	1035859	01/31/1977	W	574	3,620	3,320
7S 1E15AB2	432652103585801	432652	1035858	10/18/1978	W	350	3,623	3,373
7S 1E15AB2	432652103585802	432652	1035858	10/19/1978	W	395	3,623	3,373
7S 1E15DD	432613103584001	432613	1035840	03/05/1965	W	2,264	3,576	3,389
7S 1E21AA	432559103595301	432559	1035953	03/23/1979	W	2,500	3,533	3,193
7S 1E22AA	432559103584001	432559	1035840	01/21/1980	W	2,460	3,565	3,226

Table 1. Selected data for wells and test holes used in the structure-contour map of the Inyan Kara Group—Continued

[NGVD29, National Geodetic Vertical Datum of 1929; W, well; X, test hole; --, no data]

USGS local number	Station identification number	Latitude	Longitude	Date of construction	Type of site	Depth of hole, in feet below land surface	Altitude, in feet above NGVD29	
		(degrees, minutes, seconds)					Land surface	Top of the Inyan Kara Group ¹
Fall River County—Continued								
7S 1E22BC	432547103593501	432547	1035925	11/27/1970	W	2,545	3,534	3,208
7S 1E33AD	432401103595301	432401	1035953	10/21/1968	W	2,875	3,677	3,117
7S 2E31AC	432402103552101	432402	1035521	10/03/1968	W	2,340	3,521	3,512
7S 6E 1CDA	432754103205801	432802	1032110	06/10/1991	W	360	3,350	3,038
7S 6E23AACC	432549103215701	432549	1032153	06/--/1977	W	820	3,265	2,465
7S 6E34CADA	432400103233201	432345	1032330	10/14/1980	W	740	3,180	2,500
7S 7E 6BBBC	432834103203301	432834	1032028	06/26/1977	W	640	3,410	2,805
8S 1E12AD	432217103561601	432217	1035616	10/07/1968	W	2,760	3,680	3,180
8S 1E31DA	431835104021101	431835	1040211	01/28/1988	X	5,643	3,835	2,448
8S 2E 8CCCC	432145103545101	432145	1035451	06/18/1994	W	2,450	3,501	3,192
8S 2E 9DA	432204103524001	432204	1035240	11/30/1965	W	1,065	3,534	3,412
8S 2E10BD	432218103520601	432218	1035206	12/06/1978	W	636	3,632	3,502
8S 2E14AD	432123103501701	432124	1035017	12/24/1971	W	2,415	3,623	3,439
8S 2E14CD	432058103505101	432058	1035051	12/06/1970	W	2,433	3,624	3,367
8S 2E15AA	432137103512901	432137	1035129	12/30/1964	W	2,472	3,581	3,435
8S 2E17AB	432141103540901	432141	1035409	07/07/1994	W	2,500	3,502	3,236
8S 2E17BA	432141103543001	432141	1035430	04/21/1994	W	2,480	3,494	3,197
8S 2E20CC	432005103544501	432005	1035445	05/16/1981	W	2,900	3,592	2,991
8S 2E22BC	431845103533701	431845	1035337	--/--/1988	X	2,881	3,610	3,015
8S 2E23BBA	432048103510701	432048	1035107	06/07/1978	W	390	3,625	3,285
8S 2E23BD	432032103505301	432032	1035053	05/15/1946	W	2,537	3,570	3,290
8S 2E23CD	432004103505001	432004	1035050	10/24/1951	W	298	3,565	3,285
8S 2E24BB	432045103495901	432045	1034959	02/05/1958	W	2,545	3,600	3,341
8S 2E35BD	431835103502301	431848	1035055	06/28/1980	W	2,631	3,469	3,161
8S 2E36ADBC	431849103491301	431849	1034913	05/07/1981	W	340	3,428	3,188
8S 2E36DADB	433103103483401	431834	1034905	08/07/1983	W	300	3,425	3,180
8S 3E 8CCCA	432147103544801	432147	1035448	11/18/1993	W	2,450	3,499	3,198
8S 3E30AC	431940103481301	431940	1034813	06/17/1965	W	2,504	3,455	3,307
8S 3E33DBB	431839103465001	431839	1034555	11/05/1980	W	200	3,425	3,255
8S 6E21BD	432020103245309	432020	1032453	--/--/1957	W	--	3,266.35	2,706
8S 7E27DCC	431909103161801	431909	1031618	01/24/1946	W	4,548	3,354	1,204
9S 1E 1CABD	431736103565301	431745	1035703	09/23/1971	W	3,300	3,790	2,590
9S 1E 6BA	431810104025001	431810	1040250	--/--/1983	W	3,670	3,860	2,360

Table 1. Selected data for wells and test holes used in the structure-contour map of the Inyan Kara Group—Continued

[NGVD29, National Geodetic Vertical Datum of 1929; W, well; X, test hole; --, no data]

USGS local number	Station identification number	Latitude	Longitude	Date of construction	Type of site	Depth of hole, in feet below land surface	Altitude, in feet above NGVD29	
		(degrees, minutes, seconds)					Land surface	Top of the Inyan Kara Group ¹
Fall River County—Continued								
9S 1E12ADDC	431704103561801	431701	1035615	12/29/1963	W	3,250	3,831	2,712
9S 1E20DD	431453104010001	431455	1040100	08/29/1960	W	2,014	3,750	2,336
9S 1E23CCAD	431453103582201	431455	1035826	12/27/1968	W	2,743	3,730	2,400
9S 1E24BA	431532103565401	431532	1035654	12/15/1986	W	3,335	3,828	2,654
9S 1E29AA	431441104010301	431441	1040103	12/05/1997	W	3,488	3,750	2,339
9S 1E29BDB	431433104014001	431433	1040140	07/07/1988	W	3,665	3,770	2,310
9S 1E30DBC	431413104023401	431413	1040234	01/21/1998	W	3,666	3,836	2,281
9S 2E 1AAAC	431812103491101	431812	1034911	03/24/1908	W	2,980	3,448	3,058
9S 2E 1BCDC	431750103500301	431750	1035003	10/23/1936	W	3,183	3,571	3,086
9S 2E 2AC	431756103504201	431756	1035042	08/15/1996	W	2,730	3,598	3,109
9S 2E 2CA	431743103505901	431743	1035059	03/21/1990	W	2,716	3,652	3,067
9S 2E 5CCBD	431729103544901	431729	1035449	11/13/1976	W	3,065	3,822	2,857
9S 2E 6CA	431740103554301	431740	1035543	12/14/1971	W	3,145	3,795	2,732
9S 2E 7ABBB	431718103554201	431723	1035536	12/18/1970	W	3,250	3,877	2,783
9S 2E10DD	431637103513501	431645	1035135	12/09/1965	W	2,909	3,574	2,942
9S 2E11AC	431703103504201	431703	1035042	08/09/1996	W	2,700	3,536	3,004
9S 2E12BBAC	431716103500301	431716	1035003	05/--/1981	W	2,898	3,507	3,041
9S 2E14BA	431625103510001	431625	1035100	12/13/1985	W	2,671	3,518	2,937
9S 2E14CD	431545103510001	431545	1035100	04/15/1984	W	2,980	3,580	2,894
9S 2E15ACC	431606103515801	431606	1035158	07/15/1980	W	2,735	3,549	2,893
9S 2E15BA	431622103520601	431622	1035206	08/09/1980	W	2,900	3,636	2,893
9S 2E15BDC	431611103521801	431611	1035218	01/13/1980	W	2,800	3,638	2,885
9S 2E15CCDB	431543103522801	431543	1035228	09/09/1964	W	3,067	3,575	2,872
9S 2E16AD	432122103524201	431610	1035242	05/30/1981	W	3,347	3,642	2,862
9S 2E16DCCA	431545103530701	431545	1035307	01/22/1969	W	3,095	3,742	2,894
9S 2E20ACD	431521103540001	431521	1035400	12/13/1980	W	2,860	3,584	2,894
9S 2E21AC	431515103530501	431515	1035305	06/08/1988	W	2,850	3,570	2,863
9S 2E21BD	431520103532301	431520	1035323	08/21/1987	W	2,847	3,594	2,876
9S 2E21CB	431505103534501	431505	1035345	05/30/1986	W	2,844	3,571	2,874
9S 2E24DB	431505103493101	431505	1034931	10/18/1972	W	984	3,706	2,825
9S 2E25DC	431400103492601	431400	1034926	02/14/1985	X	3,380	3,807	2,703
9S 2E29AD	431421103535201	431421	1035352	04/21/1982	W	3,050	3,703	2,889
9S 2E30BA	431442103555001	431442	1035550	12/07/1986	W	3,330	3,725	2,659

Table 1. Selected data for wells and test holes used in the structure-contour map of the Inyan Kara Group—Continued

[NGVD29, National Geodetic Vertical Datum of 1929; W, well; X, test hole; --, no data]

USGS local number	Station identification number	Latitude	Longitude	Date of construction	Type of site	Depth of hole, in feet below land surface	Altitude, in feet above NGVD29	
		(degrees, minutes, seconds)					Land surface	Top of the Inyan Kara Group ¹
Fall River County—Continued								
9S 2E32DB	431316103542301	431316	1035423	02/14/1997	W	3,200	3,727	2,749
9S 2E35CD	431305103505801	431305	1035058	07/18/1983	W	3,380	3,717	2,658
9S 3E21D	431502103455101	431502	1034551	05/20/1973	W	1,300	3,690	2,783
9S 3E33DDDC	431310103454001	431303	1034543	--/--/1954	W	998	3,525	2,527
9S 4E19CD	431451103414401	431451	1034144	08/--/1930	W	300	3,535	3,525
9S 5E33DD	431307103313501	431307	1033135	06/14/1957	W	723	3,558	3,158
9S 5E34ACC	431331103304601	431331	1033046	11/13/1951	W	2,528	3,625	3,232
9S 6E 3ACAD	431753103233601	431755.4	1032333.8	--	W	1,695	3,209.1	1,820
9S 6E18CD	431543103272501	431543	1032725	10/27/1964	W	2,692	3,348	2,888
9S 7E16DA	431556103172501	431556	1031725	05/16/1971	W	4,335	3,350	1,377
9S 7E25AD	431420103115001	431420	1031430	10/03/1958	W	4,617	3,390	1,089
10S 1E 3AB	431255103590001	431255	1035900	01/05/1998	W	3,449	3,731	2,388
10S 1E11BB	431200103582001	431200	1035820	08/10/1958	W	1,930	3,718	2,388
10S 1E19AC	431008104023301	431008	1040233	05/29/1985	W	3,750	3,865	2,310
10S 1E19AD	431005104021101	431005	1040211	01/18/1985	W	3,750	3,871	2,313
10S 1E19DA	430952104021201	430952	1040212	06/06/1984	W	3,780	3,896	2,305
10S 1E20CBB	430957104020101	430957	1040201	12/23/1984	W	3,750	3,870	2,307
10S 1E24B	431015103565501	431015	1035655	05/24/1930	W	1,568	3,800	2,600
10S 1E32CDB	430759104014301	430759	1040143	02/21/1989	W	3,911	3,968	2,253
10S 1E32DB	430806104012401	430806	1040124	09/20/1985	W	4,005	4,019	2,267
10S 1E34DB	430808103590001	430808	1035900	09/16/1991	W	3,500	3,954	2,628
10S 1E35BDC	430815103580001	430815	1035800	12/20/1995	W	3,473	3,914	2,600
10S 2E 1DB	431233103493501	431233	1034935	04/--/1954	W	1,314	3,740	2,545
10S 2E 2CA	431233103511001	431233	1035110	04/08/1970	W	3,178	3,660	2,561
10S 2E 3ACDA	431240103453001	431240	1035150	11/26/1943	W	3,855	3,655	2,595
10S 2E 3DAA	431232103513501	431232	1035135	--	W	--	3,655	2,567
10S 2E 4BD	431242103531501	431242	1035315	06/19/1981	W	3,670	3,810	2,670
10S 2E 5BA	431257103543301	431257	1035433	07/03/1990	W	3,340	3,796	2,708
10S 2E10AA	431203103514001	431203	1035140	12/15/1994	W	3,280	3,720	2,580
10S 2E18ACD	431055103552601	431055	1035526	09/01/1989	W	4,065	3,797	2,552
10S 2E18BDB	431100103554401	431100	1035544	07/30/1992	W	3,403	3,792	2,582
10S 2E33DD	430758103524401	430758	1035244	09/07/1986	W	3,870	3,967	2,281
10S 3E15BA	431242103451001	431109	1034510	10/22/1954	W	1,238	3,570	2,364

Table 1. Selected data for wells and test holes used in the structure-contour map of the Inyan Kara Group—Continued

[NGVD29, National Geodetic Vertical Datum of 1929; W, well; X, test hole; --, no data]

USGS local number	Station identification number	Latitude	Longitude	Date of construction	Type of site	Depth of hole, in feet below land surface	Altitude, in feet above NGVD29	
		(degrees, minutes, seconds)					Land surface	Top of the Inyan Kara Group ¹
Fall River County—Continued								
10S 3E16BB	431112103463501	431112	1034635	11/14/1982	W	3,432	3,596	2,374
10S 3E25CD	430836103424801	430836	1034248	11/30/1982	W	3,604	3,506	2,163
10S 3E28AC	430920103455201	430920	1034552	11/05/1973	W	3,596	3,800	2,188
10S 3E32DACD	430801103472301	430804	1035647	09/03/1980	X	3,962	3,810	2,103
10S 4E 4CCA	431218103393001	431218	1033930	12/05/1946	W	3,004	3,475	3,035
10S 4E 8AA	431203103395201	431203	1033952	06/29/1965	W	2,768	3,502	3,034
10S 4E20D	430945103400001	430945	1034000	--/--/1937	W	3,250	3,600	2,820

¹From Carter and Redden, 1999a.

Table 2. Selected data for wells and test holes used in the structure-contour map of the Minnekahta Limestone

[NGVD29, National Geodetic Vertical Datum of 1929; W, well; X, test hole; --, no data]

USGS local number	Station identification number	Latitude	Longitude	Date of construction	Type of site	Depth of hole, in feet below land surface	Altitude, in feet above or below (-) NGVD29	
		(degrees, minutes, seconds)					Land surface	Top of the Minnekahta Limestone ¹
Butte County								
9N 6E36DA	444147103193501	444147	1031935	10/09/1976	W	5,575	2,804	-886
9N 5E24ACA	444350103270701	444350	1032704	07/12/1934	W	4,400	2,860	-1,350
9N 3E27ADBD	444253103440001	444253	1034359	07/--/1952	W	4,016	3,002	852
9N 2E34CDDBCA	444129103514801	444129	1035148	10/10/1981	W	3,320	3,185	880
8N 5E12DBC	444002103272001	444002	1032720	12/13/1949	W	5,759	2,880	-620
8N 4E13CD	443857103344801	443857	1033448	01/04/1965	W	2,677	2,930	525
8N 3E31ACA	443655103482001	443650	1034744	08/21/1960	W	1,853	3,190	1,550
8N 3E13AA	443940103412701	443940	1034127	09/16/1991	W	3,750	2,911	1,018
8N 3E 2DB	444057103425701	444057	1034257	07/25/1960	W	2,240	2,990	1,030
8N 2E28DDCB	443716103522501	443716	1035225	03/11/1980	W	2,220	3,242	1,772
8N 2E22BBDC	443839103514701	443841	1035201	--/--/1968	W	2,590	3,220	1,340
8N 1E33ABCA	443650104000801	443659	1035958	01/17/1953	W	1,450	3,490	2,370
8N 1E32AD	443648104010001	443648	1040100	--/--/1933	W	1,529	3,500	2,525
8N 1E30ABB	443758104023801	443758	1040238	06/12/1958	W	1,211	3,420	2,442
8N 1E20CACB	443826104012401	443826	1040124	--/--/1953	W	1,321	3,362.1	2,298
8N 1E19CD	443808104025001	443808	1040250	08/27/1959	W	1,214	3,391	2,417
8N 1E19CBA	443818104030001	443818	1040300	10/30/1953	W	1,585	3,406	2,421
8N 1E19ADAC	443836104020801	443837	1040200	05/12/1981	W	1,380	3,340	2,292
7N 2E 6CDBD	443534103552601	443534	1035526	06/13/1980	W	2,180	3,365	2,305
7N 2E 2BBAD	443612103504701	443612	1035047	03/09/1987	W	1,465	3,400	2,110
7N 1E11BCAD	443511103575801	443511	1035758	10/12/1977	W	1,440	3,360	2,630
7N 1E11ACAC	443515103572501	443508	1035730	06/01/1966	W	1,004	3,400	2,622
7N 1E 9CBCB	443500104004801	443500	1040048	09/26/1958	W	785	3,423	2,883
Lawrence County								
7N 4E30DCB	443205103404001	443205	1034040	11/15/1950	W	3,143	3,680	2,278
7N 3E 7AABA	443515103473001	443525	1034732	01/--/1962	W	1,653	3,360	1,907
7N 2E36CC	443350103491201	443110	1034936	08/10/1974	W	580	3,720	3,176
7N 2E34DA	443127103510601	443127	1035106	02/06/1974	W	700	3,550	2,885
7N 2E32DAAC	443128103533001	443128	1035330	09/29/1986	W	340	3,540	3,272
7N 2E32BDD	443115103540001	443137	1035406	07/13/1981	W	545	3,590	3,254
7N 2E32BB	443427103540201	443153	1035425	10/--/1960	W	540	3,560	3,205
7N 2E32BAC	443117103541301	443147	1035413	11/11/1980	W	500	3,570	3,216
7N 2E31BD	443140103543001	443140	1035525	11/01/1991	W	697	3,580	3,288

Table 2. Selected data for wells and test holes used in the structure-contour map of the Minnekahta Limestone—Continued

[NGVD29, National Geodetic Vertical Datum of 1929; W, well; X, test hole; --, no data]

USGS local number	Station identification number	Latitude	Longitude	Date of construction	Type of site	Depth of hole, in feet below land surface	Altitude, in feet above or below (-) NGVD29	
		(degrees, minutes, seconds)					Land surface	Top of the Minnekahta Limestone ¹
Lawrence County—Continued								
7N 2E31BB	440542104030601	443153	1035542	05/29/1974	W	325	3,585	3,293
7N 2E27CCA	443206103514501	443201	1035145	12/30/1986	W	1,060	3,450	2,885
7N 2E26BCDA	443230103504101	443230	1035041	05/--/1963	W	825	3,400	2,623
7N 2E24DBDD	443305103485401	443305	1034854	05/14/1981	W	940	3,405	2,605
7N 2E22BCA	443323103515501	443324	1035158	07/14/1960	W	1,218	3,437	2,481
7N 2E21AC	443325103525001	443321	1035238	01/18/1965	W	960	3,440	2,677
7N 2E21AABC	443335103522801	443335	1035228	06/16/1980	W	1,260	3,418	2,648
7N 2E20DA	443310103533501	443310	1035335	11/06/1964	W	1,115	3,390	2,848
7N 2E19CAAA	443420103551001	443315	1035514	--/--/1960	W	700	3,405	2,907
7N 2E18CA	443355103553001	443359	1035532	--/--/1960	W	845	3,390	2,754
7N 2E15DD	443348103510601	443348	1035127	05/14/1962	W	1,250	3,370	2,347
7N 2E15CC	443330103520301	443348	1035203	--	W	--	3,437	2,481
7N 2E10BADC	443515103513901	443513.1	1035143.4	05/17/1962	W	1,306.5	3,218.1	2,040
7N 1E36BDAA	443141103562301	443142	1035628	--	W	240	3,655	3,572
7N 1E33CCDD	443100104002001	443104.2	1040025.3	07/31/1987	W	1,100	3,667.0	3,371
7N 1E30DDDC	443150104020001	443156	1040205	07/17/1960	W	985	3,510	3,146
7N 1E30CADD	443330104024501	443230	1040241	05/01/1951	W	406	3,526	3,145
7N 1E30BDA2	443310104024501	443230	1040242	05/13/1952	W	402	3,510	3,151
7N 1E28CACD	443212104001601	443212	1040016	03/11/1980	W	1,530	3,535	3,269
7N 1E25DBDA	443215103561501	443215	1035610	12/31/1959	W	500	3,510	3,243
7N 1E24DC	443255103562801	443255	1035628	04/25/1960	W	360	3,460	3,104
7N 1E23CBDC	443310103582301	443303	1035803	--/--/1954	W	568	3,470	3,172
7N 1E20CC	443300104015501	443300	1040155	05/25/1962	W	950	3,530	2,945
7N 1E19DCCC	443255104020301	443251	1040233	11/23/1960	W	645	3,520	3,085
7N 1E17AA	443430104010501	443430	1040105	07/14/1975	W	644	3,411.3	2,857
7N 1E14CCDD2	443355103574502	443343	1035802	05/14/1972	W	620	3,474	3,060
6N 4E36CBAA	442610103350001	442616	1033505	05/17/1974	W	460	3,595	3,375
6N 4E36CACD	442610103345501	442605	1033453	02/16/1973	W	400	3,604	3,439
6N 4E36BDAB	442628103345101	442628	1033451	12/22/1987	W	380	3,505	3,160
6N 4E35ADBC	442624103353301	442624	1033533	06/08/1984	W	315	3,560	3,519
6N 4E33ABDC	442708103382001	442630	1033809	07/10/1991	W	460	3,750	3,658
6N 4E32AD	442626103390101	442626	1033901	04/26/1978	W	310	3,960	3,715
6N 4E31ADDD	442610103401701	442610	1034017	05/19/1980	W	700	4,040	3,685

Table 2. Selected data for wells and test holes used in the structure-contour map of the Minnekahta Limestone—Continued

[NGVD29, National Geodetic Vertical Datum of 1929; W, well; X, test hole; --, no data]

USGS local number	Station identification number	Latitude	Longitude	Date of construction	Type of site	Depth of hole, in feet below land surface	Altitude, in feet above or below (-) NGVD29	
		(degrees, minutes, seconds)					Land surface	Top of the Minnekahta Limestone ¹
Lawrence County—Continued								
6N 4E22CBCB	442845103363001	442753	1033710	10/--/1924	W	1,020	3,600	3,249
6N 4E21DBCD	442749103381401	442749	1033814	10/13/1961	W	630	3,620	3,400
6N 4E21AC	442807103381101	442807	1033811	05/--/1924	W	957	3,590	3,239
6N 4E16DDBB	442835103380101	442835	1033801	08/25/1986	W	1,442	3,560	3,060
6N 4E16DA	442845103375301	442845	1033753	03/08/1981	W	810	3,620	3,055
6N 3E26BDBD	442715103432301	442715	1034323	03/10/1976	W	880	3,898	3,833
6N 3E20DDDC	442736103461401	442736	1034614	12/20/1979	W	720	4,020	4,000
6N 3E20BAAC	442823103465201	442823	1034652	04/02/1993	W	902	3,940	3,830
6N 3E18BDAD	442856103475701	442901	1034757	06/--/1979	W	900	3,900	3,758
6N 3E17ABAA2	442913103465401	442917	1034630	03/22/1976	W	700	3,830	3,420
6N 3E15BADD	442907103442301	442907	1034423	07/30/1971	W	598	3,840	3,536
6N 3E14BAAB	442837103431401	442918	1034314	06/08/1966	W	280	3,675	3,555
6N 3E 8DC	442923103463801	442923	1034638	10/17/1992	W	662	3,830	3,416
6N 2E23DD	442741103495601	442741	1034956	08/20/1977	W	540	4,042	4,038
6N 2E14CBCC	442842103505501	442842	1035055	08/31/1993	W	842	3,760	3,758
6N 2E14CA	442855103503501	442855	1035035	06/01/1987	W	1,180	3,870	3,608
6N 2E14BCCC2	442854103505602	442854.4	1035053.6	08/19/1988	W	680	3,735.4	3,670
6N 2E 8AA	443010103533001	443010	1035330	12/18/1989	W	268	3,650	3,562
6N 2E 6DACD	443026103544601	443026	1035446	07/15/1988	W	340	3,720	3,597
6N 2E 6DACC	443025103544501	443028	1035453	06/30/1988	W	267	3,710	3,637
6N 2E 5DC2	443020103525001	443020	1035350	10/15/1988	W	285	3,625	3,510
6N 2E 5CBDB	443035103543001	443035	1035430	11/01/1990	W	290	3,655	3,545
6N 2E 5BBBB2	443100103543002	443104.3	1035437.7	07/03/1986	W	290	3,677.4	3,411
6N 2E 5BB	443057103535101	443057	1035428	05/10/1977	W	185	3,660	3,505
6N 2E 4BDDA	443044103525701	443044	1035257	11/13/1979	W	300	3,550	3,301
6N 2E 4BD	443046103525301	443046	1035253	11/--/1983	W	250	3,530	3,292
6N 2E 4BADA	443056103525001	443056	1035250	07/02/1985	W	340	3,520	3,225
6N 1E 8BCBC	442952104015101	442952	1040151	10/18/1969	W	320	3,900	3,893
6N 1E 6BDAB	443049104024501	443049	1040245	02/--/1977	W	430	3,785	3,715
6N 1E 6ADCD	443039104020901	443039	1040209	--/--/1961	W	315	3,795	3,658
6N 1E 5DDDA	443015104003701	443015	1040042	01/26/1962	W	195	3,735	3,583
6N 1E 5ABCD	443020104004901	443052	1040109	--/--/1960	W	325	3,690	3,421
5N 4E 1ABBD2	442545103343702	442544.3	1033437.1	11/30/1990	W	822	3,629.7	3,500

Table 2. Selected data for wells and test holes used in the structure-contour map of the Minnekahta Limestone—Continued

[NGVD29, National Geodetic Vertical Datum of 1929; W, well; X, test hole; --, no data]

USGS local number	Station identification number	Latitude	Longitude	Date of construction	Type of site	Depth of hole, in feet below land surface	Altitude, in feet above or below (-) NGVD29	
		(degrees, minutes, seconds)					Land surface	Top of the Minnekahta Limestone ¹
Meade County								
6N 6E19BCAA	442813103263901	442813	1032639	06/01/1956	W	1,350	3,190	2,810
6N 6E19BBBA	442824103264101	442824	1032641	09/24/1993	W	900	3,200	2,940
6N 5E14ADBD	442901103281601	442901	1032816	10/28/1980	W	1,100	3,100	2,195
5N 5E36DBCB	442058103273001	442058	1032730	08/--/1976	W	1,368	3,720	3,365
5N 5E36ADD	442108103270301	442108	1032703	06/09/1976	W	1,120	3,690	2,826
5N 5E26ABDA	442217103272201	442215	1032829	--/--/1952	W	1,470	3,625	3,066
5N 5E26AA	442215103281701	442215	1032817	06/15/1991	W	1,140	3,605	2,795
5N 5E25CADB	442146103272001	442152	1032742	10/05/1973	W	1,000	3,710	2,960
5N 5E21AAA	442311103303501	442311	1033035	10/--/1967	W	883	3,600	3,480
5N 5E16DABA	442441103304201	442340	1033042	12/04/1964	W	600	3,570	3,306
5N 5E11BDCA	442440103285501	442440	1032855	06/28/1937	W	1,800	3,335	1,895
5N 5E 9DCBBA	442416103310301	442419	1033105	--/--/1958	W	744	3,500	3,215
5N 5E 9BCAA	442443103312701	442443	1033127	08/--/1960	W	902	3,530	3,150
5N 5E 9ABCC	442453103310301	442448	1033104	06/03/1955	W	1,060	3,460	2,995
5N 5E 8ACDD	442435103320301	442435	1033203	07/09/1981	W	515	3,565	3,427
5N 5E 8ACC	442435103321601	442435	1033216	06/08/1994	W	380	3,580	3,470
5N 5E 7AAB	442456103330801	442456	1033308	--/--/1971	W	320	3,580	3,481
5N 5E 6ACAD	442540103325801	442532	1033315	--/--/1974	W	620	3,590	3,175
5N 5E 5DDC	442502103315701	442502	1033157	--/--/1965	W	508	3,480	3,173
5N 5E 5DCAC	442506103321201	442506	1033212	06/07/1977	W	604	3,498	3,158
5N 5E 5CCCA	442502103325201	442502	1033252	08/10/1977	W	435	3,525	3,375
5N 5E 5BCB	442536103323501	442536	1033252	--/--/1974	W	720	3,555	3,155
5N 5E 4CBCC	442514103314101	442514	1033141	02/28/1984	W	1,497	3,461	3,001
5N 5E 3BCD	442529103301401	442529	1033014	05/15/1992	W	1,740	3,460	2,140
4N 6E19AABA2	441759103261202	441759.7	1032612.2	11/19/1990	W	840	3,639.1	3,497
4N 6E16DCB	441812103230501	441812	1032405	01/16/1961	W	1,460	3,460	2,355
4N 5E 1AC	442020103273801	442020	1032738	11/25/1980	W	85	3,780	3,772
3N 7E31CBBC	441031103195201	441031	1031953	02/19/1976	W	530	3,690	3,585
3N 7E31CAA	441033103193001	441033	1031930	10/11/1975	W	640	3,630	3,320
3N 7E30CDD	441105103192001	441105	1031920	06/30/1988	W	1,120	3,650	2,825
3N 7E30BCAD	441147103270001	441138	1031940	10/27/1976	W	1,600	3,870	2,635
3N 7E19DBDA	441214103191001	441214	1031910	07/04/1970	W	1,653	3,716	2,849
3N 7E19CDA	441204103192301	441204	1031923	06/08/1950	W	2,155	3,670	2,726

Table 2. Selected data for wells and test holes used in the structure-contour map of the Minnekahta Limestone—Continued

[NGVD29, National Geodetic Vertical Datum of 1929; W, well; X, test hole; --, no data]

USGS local number	Station identification number	Latitude	Longitude	Date of construction	Type of site	Depth of hole, in feet below land surface	Altitude, in feet above or below (-) NGVD29	
		(degrees, minutes, seconds)					Land surface	Top of the Minnekahta Limestone ¹
Meade County—Continued								
3N 7E19BDDD	441227103192801	441227	1031928	09/10/1949	W	1,368	3,560	2,790
3N 7E19ADAB	441231103184701	441231	1031847	11/02/1942	W	1,250	3,440	2,423
3N 7E19AC	441227103191001	441227	1031910	05/30/1950	W	1,235	3,675	2,799
3N 7E18BDAC	441322103192301	441322	1031923	04/24/1979	W	1,160	3,630	2,492
3N 6E36DD	441017103201001	441017	1032010	05/--/1961	W	210	3,700	3,698
3N 6E36DBD	441024103201301	441024	1032013	06/17/1972	W	440	3,720	3,615
3N 6E25ADDA	441131103200101	441131	1032001	11/03/1976	W	805	3,615	3,048
3N 6E24DBDA	441212103201501	441212	1032015	08/16/1972	W	1,542	3,840	2,623
3N 6E24CABB	441219103204801	441219	1032048	09/06/1979	W	1,005	3,570	2,879
3N 6E23DDAC	441202103211301	441207	1032115	07/31/1980	W	860	3,558	3,358
3N 6E23DCB	441206103213701	441206	1032137	05/09/1980	W	330	3,600	3,510
3N 6E15DABBB	441315103224001	441315	1032236	07/23/1987	W	365	3,530	3,440
3N 6E15ABB2	441337103225002	441335.5	1032250.5	08/29/1994	W	880	3,476.8	3,285
3N 6E15AAAC	441333103222801	441333	1032228	02/15/1979	W	640	3,470	3,140
3N 6E14CBA	441319103220201	441309	1032208	06/02/1973	W	880	3,485	3,005
3N 6E10CC	441345103232501	441345	1032325	04/20/1978	W	120	3,540	3,445
3N 6E10CA	441359103230501	441359	1032305	07/22/1979	W	195	3,460	3,270
3N 6E 4CB	441453103243801	441453	1032438	04/08/1986	W	328	3,570	3,530
3N 6E 4CAD	441448103241501	441448	1032415	05/21/1988	W	241	3,540	3,317
3N 6E 4BBAA	441522103242801	441527	1032425	08/15/1972	W	260	3,530	3,335
3N 6E 3BCBC	441504103230301	441509	1032332	09/04/1979	W	755	3,460	2,990
2N 9E18BAB	440824103050601	440824	1030506	04/17/1942	W	4,645	3,195	-190
2N 8E13BDC	440801103061601	440801	1030616	07/12/1942	W	4,440	3,199	-160
2N 7E10CDCA	440832103160901	440837	1031609	11/19/1956	W	1,048	3,395	2,771
2N 7E 9AABB	440916103163301	440916	1031633	04/11/1979	W	1,260	3,420	2,703
2N 7E 8DDCC	440826103174601	440826	1031746	08/24/1977	W	815	3,600	3,100
2N 7E 8CDB	440835103182001	440835	1031820	--/--/1960	W	955	3,545	3,183
2N 7E 8BBC	441636103183801	440907	1031838	05/22/1986	W	1,180	3,530	3,250
2N 7E 6DCD	440930103190501	440930	1031905	09/--/1959	W	360	3,520	3,470
2N 7E 6DAA	440939103184701	440939	1031847	12/--/1959	W	575	3,550	3,206
2N 7E 6CDAC	440936103191801	440926	1031925	01/25/1981	W	340	3,545	3,531
2N 7E 5DDA	440927103173501	440927	1031735	07/06/1988	W	885	3,440	2,890
2N 7E 5CA2	440938103181501	440938	1031815	08/23/1997	W	760	3,480	3,050

Table 2. Selected data for wells and test holes used in the structure-contour map of the Minnekahta Limestone—Continued

[NGVD29, National Geodetic Vertical Datum of 1929; W, well; X, test hole; --, no data]

USGS local number	Station identification number	Latitude	Longitude	Date of construction	Type of site	Depth of hole, in feet below land surface	Altitude, in feet above or below (-) NGVD29	
		(degrees, minutes, seconds)					Land surface	Top of the Minnekahta Limestone ¹
Meade County—Continued								
2N 7E 4CDCD	440919103170501	440920	1031658	03/--/1959	W	930	3,405	2,810
2N 7E 2DBDD	440939103142001	440939	1031420	04/23/1980	W	2,103	3,375	1,488
2N 7E 2DBDDC	440931103141401	440931	1031414	04/23/1980	W	3,060	3,383	1,488
Pennington County								
2N 9E29BBCC	440629103040901	440629	1030409	03/18/1983	W	4,450	3,043	-247
2N 7E34CC	440502103160902	440502	1031609	08/01/1995	W	600	3,350	2,950
2N 7E34BDCC2	440524103154001	440524	1031558	06/--/1960	W	1,275	3,325	3,165
2N 7E34BCCA	440528103161001	440530.9	1031614.2	05/24/1964	W	400	3,328.9	3,273
2N 7E34BAAC	440544103154901	440544	1031549	09/20/1983	W	480	3,380	3,125
2N 7E33DADA	440508103163501	440513	1031620	08/22/1951	W	225	3,380	3,355
2N 7E33BCD	440525103171701	440525	1031717	12/16/1986	W	240	3,430	3,429
2N 7E33BCAA	440534103171401	440534	1031714	05/05/1978	W	225	3,460	3,450
2N 7E28DACD	440552103162301	440601	1031629	--/--/1959	W	300	3,360	3,330
2N 7E27DABB	440612103152001	440612	1031522	08/12/1991	W	1,787	3,363.1	2,825
2N 7E27CAAB	440607103155901	440613	1031549	07/29/1983	W	615	3,360	2,968
2N 7E27BCAA	440626103154701	440626	1031602	09/10/1979	W	380	3,390	3,044
2N 7E27BBCB	440635103161801	440631	1031617	--/--/1961	W	505	3,450	3,195
2N 7E27BBB	440635103161401	440635	1031614	--/--/1961	W	615	3,451	3,184
2N 7E27AABA	440636103152001	440636	1031520	04/--/1959	W	992	3,435	2,815
2N 7E23DACA	440659103140501	440659	1031405	02/08/1991	W	2,680	3,500	2,060
2N 7E21DAAA	440706103162001	440706	1031620	12/03/1979	W	452	3,500	3,063
2N 7E20CAAC	440702103181401	440702	1031814	11/12/1988	W	380	3,580	3,520
2N 7E17DDAA	440736103173701	440736	1031737	--	W	400	3,450	3,370
2N 7E17D	440747103174901	440747	1031749	04/20/1994	W	440	3,460	3,320
2N 7E17BAAD	440818103180801	440819.8	1031809.9	07/03/1984	W	560	3,501.8	3,216
2N 7E16AAB	440823103162701	440823	1031627	08/30/1989	W	1,530	3,400	2,925
1N 9E22BA	440212103012101	440212	1030121	07/15/1952	W	4,185	3,052	-428
1N 8E 9CAB2	440334103095601	440334	1030956	09/--/1990	W	3,805	3,108	576
1N 7E34BAC	440028103160801	440028	1031608	10/03/1985	W	660	3,815	3,540
1N 7E33BAC	440025103170801	440025	1031708	06/29/1994	W	440	3,780	3,730
1N 7E33ADBB	440007103165301	440017	1031632	--	W	540	3,840	3,455
1N 7E27DDAB	440041103151401	440041	1031514	05/--/1962	W	1,320	3,820	2,780
1N 7E27DADB	440059103154101	440051	1031512	11/20/1970	W	1,430	3,815	2,725

Table 2. Selected data for wells and test holes used in the structure-contour map of the Minnekahta Limestone—Continued

[NGVD29, National Geodetic Vertical Datum of 1929; W, well; X, test hole; --, no data]

USGS local number	Station identification number	Latitude	Longitude	Date of construction	Type of site	Depth of hole, in feet below land surface	Altitude, in feet above or below (-) NGVD29	
		(degrees, minutes, seconds)					Land surface	Top of the Minnekahta Limestone ¹
Pennington County—Continued								
1N 7E26CCAA	440048103145001	440048	1031450	05/02/1984	W	1,460	3,820	2,620
1N 7E26BCDA	440103103144801	440103	1031448	04/06/1984	W	1,545	3,720	2,470
1N 7E23CAB	440149103144301	440149	1031443	06/24/1992	W	1,563	3,810	2,430
1N 7E23BDAB	440203103143601	440203	1031436	--/--/1973	W	1,878	3,840	2,380
1N 7E22DCC	440130103153901	440130	1031539	08/31/1993	W	875	3,780	3,038
1N 7E22BDCC	440158103160401	440155	1031600	11/18/1972	W	445	3,565	3,315
1N 7E22ABCB	440120103153401	440211	1031534	--/--/1960	W	780	3,480	2,910
1N 7E21DBA	440148103164101	440148	1031641	10/11/1985	W	602	3,620	3,608
1N 7E21BDA	440202103165801	440202	1031658	05/23/1985	W	565	3,760	3,745
1N 7E21BCAB	440205103172001	440205	1031720	07/07/1982	W	--	3,900	3,795
1N 7E16DCD	440220103164001	440220	1031640	12/01/1991	W	1,281	3,486.7	3,482
1N 7E16CCCA	440224103172601	440224	1031726	07/10/1977	W	612	3,800	3,795
1N 7E16BAAB	440309103170101	440309	1031701	03/24/1979	W	200	3,430	3,422
1N 7E15CCBC	440223103161701	440229	1031616	--/--/1970	W	500	3,440	3,295
1N 7E15CBBD2	440244103154102	440240	1031612	--	W	460	3,475	3,320
1N 7E15BBC	440302103161401	440302	1031614	03/30/1992	W	430	3,400	3,150
1N 7E15BAD	440244103154301	440302	1031549	--/--/1955	W	921	3,470	3,000
1N 7E14CBCA	440236103145801	440236	1031458	08/23/1973	W	1,660	3,880	2,500
1N 7E14BABD	440308103144301	440305	1031442	03/14/1983	W	1,817	3,833	2,419
1N 7E11DBAD	440331103142701	440237	1031414	11/11/1980	W	1,755	3,560	2,370
1N 7E10CADD	440331103155101	440331	1031551	10/28/1958	W	700	3,410	2,960
1N 7E 5ACAB	440441103175401	440441	1031754	--/--/1958	W	60.0	3,510	3,464
1N 7E 3CBAA	440430103160201	440427.2	1031605.1	05/24/1964	W	570	3,300	3,057
1N 7E 3BCBC	440436103161201	440436	1031612	02/05/1940	W	635	3,343	3,061
1N 7E 3AAB	444153103151901	440453	1031519	07/--/1941	W	1,385	3,260	2,610
1S 7E11ACAB	435851103143501	435848	1031445	06/10/1984	W	1,740	3,466.2	2,811
1S 7E13CBCA	435720103141601	435739	1031416	10/30/1972	W	1,555	3,780	2,590
1S 7E14CCBB	435733103152801	435733	1031528	--	W	560	3,680	3,300
1S 7E15ABC	435803103160301	435803	1031603	09/10/1987	W	245	3,680	3,605
1S 7E27BACA	435619103161901	435619	1031619	05/30/1978	W	1,280	4,140	3,765
1S 8E19BBBB	435718103130301	435718	1031303	03/08/1984	W	2,600	3,555	1,950
2S 7E10BAD	435340103161001	435340	1031610	04/22/1992	W	675	3,660	3,175

Table 2. Selected data for wells and test holes used in the structure-contour map of the Minnekahta Limestone—Continued

[NGVD29, National Geodetic Vertical Datum of 1929; W, well; X, test hole; --, no data]

USGS local number	Station identification number	Latitude	Longitude	Date of construction	Type of site	Depth of hole, in feet below land surface	Altitude, in feet above or below (-) NGVD29	
		(degrees, minutes, seconds)					Land surface	Top of the Minnekahta Limestone ¹
Custer County								
2S 7E28ADCB	435053103170001	435053	1031700	11/21/1983	W	300	3,760	3,715
2S 7E34ABBA	435018103155801	435020.3	1031600.3	07/27/1983	W	510	3,477.5	3,184
3S 7E 5DDCA	434847103175801	434842	1031805	03/01/1990	W	287	3,690	3,610
3S 7E10BADB	434832103161701	434829	1031611	01/01/1976	W	605	3,505	3,095
3S 7E16ACBD	434726103171501	434726	1031715	02/01/1989	W	560	3,590	3,275
3S 7E33AACB	434502103165801	434502	1031658	--/--/1964	W	1,070	3,655	2,845
4S 6E 1DAAA	434350103201901	434350.8	1032020.2	08/05/1993	W	680	3,860	3,824
4S 7E25CCA	434006103140601	434006	1031406	10/17/1949	W	3,136	3,396	1,281
4S 7E25DDDB	434001103131301	434001	1031313	07/04/1949	W	2,824	3,392	1,255
4S 8E12AA	434316103061101	434316	1030611	10/25/1980	W	3,773	3,158	-209
5S 1E26CC	433452103582401	433452	1035824	07/24/1961	W	950	4,060	3,755
5S 1E26DC	433452103574801	433452	1035748	12/07/1960	W	901	4,019	3,889
5S 2E30CA	433505103554201	433505	1035542	11/26/1946	W	854	4,332	4,331
6S 1E 1BC	433338103571301	433336	1035713	--/--/1933	W	1,047	4,040	4,031
6S 1E 7DA	433241104021701	433241	1040217	01/06/1977	W	2,328	3,741	2,263
6S 2E 7CAD	433226103553701	433226	1035537	11/13/1958	W	1,201	4,040	3,616
6S 2E 8AA	433254103535201	433254	1035352	08/15/1957	W	1,225	4,088	3,550
6S 2E 9BC	433241103533401	433241	1035334	12/19/1956	W	1,656	4,071.5	3,511
6S 2E14CB	433135103511701	433135	1035117	12/20/1993	W	1,326	4,383	3,639
6S 2E22DD	433030103512701	433030	1035127	06/23/1984	X	1,470	4,190	3,468
6S 2E27CCD	432936103521701	432936	1035217	10/06/1956	W	1,378	4,123	3,558
6S 2E27DB	432952103514601	432952	1035146	10/31/1964	W	1,541	4,126	3,507
6S 2E33AD	432914103524101	432914	1035241	11/04/1958	W	1,454	4,203	3,554
6S 2E34ABC	432923103515001	432923	1035150	11/30/1963	W	1,385	4,133	3,543
6S 2E34BAA	432929103515901	432929	1035159	08/13/1957	W	1,980	4,101	3,543
6S 2E34BDC	432910103520701	432910	1035207	11/02/1963	W	1,931	4,223	3,543
6S 2E34CA(3)	432858103520101	432858	1035201	09/21/1958	W	1,455	4,199	3,501
6S 2E34CB	432902103522101	432902	1035221	09/05/1958	W	1,454	4,207	3,492
6S 2E34DBA	432904103514201	432904	1035142	--/--/1956	W	1,650	4,205	3,530
6S 5E25ADD	433513103203201	433003	1032742	--/--/1951	W	580	3,935	3,779
6S 6E 2BBCD	433341103224501	433341	1032245	08/18/1960	W	352	3,647	3,311
6S 6E20CA2	433142103232801	433142	1032328	03/--/1924	W	962	3,729	3,542
6S 6E21BBBB	433115103251401	433115.4	1032516.1	10/17/1991	W	1,165	3,645.8	3,406

Table 2. Selected data for wells and test holes used in the structure-contour map of the Minnekahta Limestone—Continued

[NGVD29, National Geodetic Vertical Datum of 1929; W, well; X, test hole; --, no data]

USGS local number	Station identification number	Latitude	Longitude	Date of construction	Type of site	Depth of hole, in feet below land surface	Altitude, in feet above or below (-) NGVD29	
		(degrees, minutes, seconds)					Land surface	Top of the Minnekahta Limestone ¹
Fall River County								
7S 1E 2DD	432758103572901	432758	1035729	08/19/1964	W	2,450	3,792	2,312
7S 1E11DC	432705103574601	432705	1035746	12/--/1976	W	2,250	3,679	2,267
7S 1E14BA	432652103580501	432652	1035805	12/26/1975	W	2,269	3,639	2,209
7S 1E15CCD	432611103592801	432611	1035928	08/--/1979	W	2,462	3,564	1,874
7S 1E15DD	432613103584001	432613	1035840	03/05/1965	W	2,264	3,576	2,056
7S 1E21AA	432559103595301	432559	1035953	03/23/1979	W	2,500	3,533	1,831
7S 1E22BC	432547103593501	432547	1035925	11/27/1970	W	2,545	3,534	1,829
7S 1E24CB	432533103570901	432533	1035709	10/06/1964	W	2,480	3,566	2,168
7S 1E33AD	432401103595301	432401	1035953	10/21/1968	W	2,875	3,677	1,777
7S 1E35DD	432336103572701	432336	1035727	07/02/1989	W	2,558	3,555	1,951
7S 2E 2ABB	432834103504001	432834	1035040	06/03/1981	W	1,680	4,121	3,441
7S 2E 2BA	432834103504701	432834	1035047	08/17/1970	W	1,470	4,099	3,449
7S 2E12CC	432702103495901	432702	1034959	11/01/1966	W	1,526	3,983	3,183
7S 2E21ACDC	432546103525801	432540	1035256	09/20/1964	W	2,225	3,810	2,689
7S 2E26ACBA	432453103503601	432458	1035036	12/14/1968	W	2,300	4,160	2,908
7S 2E26ACBA	432453103503601	432458	1035036	12/14/1968	W	2,300	4,160	2,908
7S 2E26ACBA	432453103503601	432458	1035036	12/14/1968	W	2,300	4,160	2,908
7S 2E26ACBA	432453103503601	432458	1035036	12/14/1968	W	2,300	4,160	2,908
7S 2E31AC	432402103552101	432402	1035521	10/03/1968	W	2,340	3,521	2,131
7S 3E10CD	432703103445901	432703	1034459	05/30/1969	W	1,248	4,007	3,736
7S 4E10DADC	432717103372501	432706	1033715	11/12/1980	W	120	4,100	4,084
7S 4E19BCCB	432548103414801	432545.8	1034151.2	08/29/1992	W	1,540	4,175.15	3,838
7S 4E19BCCB2	432548103414802	432545.8	1034151.2	12/14/1994	W	710	4,175.1	3,818
7S 4E30DC	432425103410501	432425	1034105	08/26/1965	W	1,680	4,262	3,533
7S 5E 2CDC	432747103291201	432747	1032930	04/21/1988	W	135	3,850	3,635
7S 5E11ACB	432726103292501	432726	1032925	--	W	65	3,600	3,540
7S 5E12CAA	432704103283801	432704	1032838	05/03/1983	W	266	3,600	3,355
7S 5E13CBDA	432619103283501	432619	1032835	02/--/1954	W	264	3,565.97	3,336
7S 5E14D	432614103290901	432614	1032909	--	W	325	3,500	3,432
7S 5E14DCDD	432602103291001	432602	1032910	07/12/1989	W	200	3,560	3,380
7S 5E24ADD	432537103274601	432537	1032746	01/29/1990	W	520	3,610	3,130
7S 5E26CCDD	432423103294701	432423	1032947	10/03/1977	W	260	3,665	3,467
7S 5E29AC	432448103325101	432448	1033251	--/--/1959	W	400	3,960	3,850

Table 2. Selected data for wells and test holes used in the structure-contour map of the Minnekahta Limestone—Continued

[NGVD29, National Geodetic Vertical Datum of 1929; W, well; X, test hole; --, no data]

USGS local number	Station identification number	Latitude	Longitude	Date of construction	Type of site	Depth of hole, in feet below land surface	Altitude, in feet above or below (-) NGVD29	
		(degrees, minutes, seconds)					Land surface	Top of the Minnekahta Limestone ¹
Fall River County—Continued								
7S 5E33DDDB	432331103312001	432331	1033120	11/10/1989	W	460	3,830	3,660
7S 5E34BDC	432352103303601	432352	1033036	08/--/1978	W	523	3,750	3,578
8S 1E12AD	432217103561601	432217	1035616	10/07/1968	W	2,760	3,680	1,862
8S 1E31DA	431835104021101	431835	1040211	01/28/1988	X	5,643	3,835	1,151
8S 2E 2AB	432322103503501	432322	1035035	12/20/1985	W	2,374	3,813	2,480
8S 2E 8BD	432215103542701	432215	1035427	07/25/1994	W	2,400	3,470	1,942
8S 2E 8CCCC	432145103545101	432145	1035451	06/18/1994	W	2,450	3,501	1,851
8S 2E14AD	432123103501701	432124	1035017	12/24/1971	W	2,415	3,623	2,065
8S 2E14CD	432058103505101	432058	1035051	12/06/1970	W	2,433	3,624	2,015
8S 2E15AA	432137103512901	432137	1035129	12/30/1964	W	2,472	3,581	2,083
8S 2E17AB	432141103540901	432141	1035409	07/07/1994	W	2,500	3,502	1,882
8S 2E17BA	432141103543001	432141	1035430	04/21/1994	W	2,480	3,494	1,853
8S 2E20CC	432005103544501	432005	1035445	05/16/1981	W	2,900	3,592	1,702
8S 2E22BC	431845103533701	431845	1035337	--/--/1988	X	2,881	3,610	1,718
8S 2E23BD	432032103505301	432032	1035053	05/15/1946	W	2,537	3,570	1,978
8S 2E24BB	432045103495901	432045	1034959	02/05/1958	W	2,545	3,600	1,987
8S 2E35BD	431835103502301	431848	1035055	06/28/1980	W	2,631	3,469	1,848
8S 3E 8CCCA	432147103544801	432147	1035448	11/18/1993	W	2,450	3,499	1,858
8S 3E 8DB	432205103470301	432205	1034703	11/22/1945	W	2,204	3,600	2,427
8S 3E14AC	432123103432901	432123	1034329	07/20/1968	W	2,425	4,029	2,752
8S 3E17CA	432111103472201	432111	1034722	08/02/1968	W	2,270	3,589	2,234
8S 3E24DAAC	432020103415801	432020	1034158	08/24/1965	W	1,970	4,033	3,043
8S 3E30AC	431940103481301	431940	1034813	06/17/1965	W	2,504	3,455	1,949
8S 3E36BDD	431844103423101	431844	1034231	10/14/1942	W	2,338	4,038	2,918
8S 4E 6DD	432238103404501	432238	1034045	08/24/1969	X	2,048	4,673	3,357
8S 4E18DA	432113103405001	432113	1034050	06/12/1981	W	2,296	4,426	3,118
8S 4E23AC	432030103362301	432030	1033623	05/29/1969	W	2,375	3,990	2,599
8S 7E27DCC	431909103161801	431909	1031618	01/24/1946	W	4,548	3,354	-146
9S 1E 1CABD	431736103565301	431745	1035703	09/23/1971	W	3,300	3,790	1,388
9S 1E 6BA	431810104025001	431810	1040250	--/--/1983	W	3,670	3,860	1,105
9S 1E12ADDC	431704103561801	431701	1035615	12/29/1963	W	3,250	3,831	1,554
9S 1E23CCAD	431453103582201	431455	1035826	12/27/1968	W	2,743	3,730	1,210
9S 1E24BA	431532103565401	431532	1035654	12/15/1986	W	3,335	3,828	1,385

Table 2. Selected data for wells and test holes used in the structure-contour map of the Minnekahta Limestone—Continued

[NGVD29, National Geodetic Vertical Datum of 1929; W, well; X, test hole; --, no data]

USGS local number	Station identification number	Latitude	Longitude	Date of construction	Type of site	Depth of hole, in feet below land surface	Altitude, in feet above or below (-) NGVD29	
		(degrees, minutes, seconds)					Land surface	Top of the Minnekahta Limestone ¹
Fall River County—Continued								
9S 1E29AA	431441104010301	431441	1040103	12/05/1997	W	3,488	3,750	1,107
9S 1E29BDB	431433104014001	431433	1040140	07/07/1988	W	3,665	3,770	1,050
9S 1E30DBC	431413104023401	431413	1040234	01/21/1998	W	3,666	3,836	1,011
9S 2E 1ACDB	431753103492601	431753	1034926	03/20/1913	W	2,983	3,455	1,765
9S 2E 1BCDC	431750103500301	431750	1035003	10/23/1936	W	3,183	3,571	1,751
9S 2E 1CBBC	431743103501401	431743	1035014	06/23/1962	W	3,050	3,575	1,770
9S 2E 2AC	431756103504201	431756	1035042	08/15/1996	W	2,730	3,598	1,808
9S 2E 2CA	431743103505901	431743	1035059	03/21/1990	W	2,716	3,652	1,756
9S 2E 5CCBD	431729103544901	431729	1035449	11/13/1976	W	3,065	3,822	1,665
9S 2E 6CA	431740103554301	431740	1035543	12/14/1971	W	3,145	3,795	1,535
9S 2E 7ABBB	431718103554201	431723	1035536	12/18/1970	W	3,250	3,877	1,543
9S 2E10DD	431637103513501	431645	1035135	12/09/1965	W	2,909	3,574	1,652
9S 2E11AC	431703103504201	431703	1035042	08/09/1996	W	2,700	3,536	1,706
9S 2E12BBAC	431716103500301	431716	1035003	05/--/1981	W	2,898	3,507	1,729
9S 2E14BA	431625103510001	431625	1035100	12/13/1985	W	2,671	3,518	1,653
9S 2E14CD	431545103510001	431545	1035100	04/15/1984	W	2,980	3,580	1,648
9S 2E15ACC	431606103515801	431606	1035158	07/15/1980	W	2,735	3,549	1,665
9S 2E15BA	431622103520601	431622	1035206	08/09/1980	W	2,900	3,636	1,613
9S 2E16AD	432122103524201	431610	1035242	05/30/1981	W	3,347	3,642	1,612
9S 2E16DCCA	431545103530701	431545	1035307	01/22/1969	W	3,095	3,742	1,619
9S 2E20ACD	431521103540001	431521	1035400	12/13/1980	W	2,860	3,584	1,631
9S 2E20DA	431509103535801	431509	1035410	05/24/1953	W	2,865	3,615	1,635
9S 2E21AC	431515103530501	431515	1035305	06/08/1988	W	2,850	3,570	1,601
9S 2E21BD	431520103532301	431520	1035323	08/21/1987	W	2,847	3,594	1,618
9S 2E21CB	431505103534501	431505	1035345	05/30/1986	W	2,844	3,571	1,621
9S 2E25DC	431400103492601	431400	1034926	02/14/1985	X	3,380	3,807	1,417
9S 2E29AD	431421103535201	431421	1035352	04/21/1982	W	3,050	3,703	1,601
9S 2E30BA	431442103555001	431442	1035550	12/07/1986	W	3,330	3,725	1,339
9S 2E32DB	431316103542301	431316	1035423	02/14/1997	W	3,200	3,727	1,467
9S 2E35CD	431305103505801	431305	1035058	07/18/1983	W	3,380	3,717	1,366
9S 3E25DD	431400103421001	431400	1034210	08/28/1964	W	2,485	3,440	2,090
9S 4E 7BBAC	431715103415301	431718	1034155	05/16/1969	W	2,000	3,966	2,608
9S 5E34ACC	431331103304601	431331	1033046	11/13/1951	W	2,528	3,625	1,915

Table 2. Selected data for wells and test holes used in the structure-contour map of the Minnekahta Limestone—Continued

[NGVD29, National Geodetic Vertical Datum of 1929; W, well; X, test hole; --, no data]

USGS local number	Station identification number	Latitude	Longitude	Date of construction	Type of site	Depth of hole, in feet below land surface	Altitude, in feet above or below (-) NGVD29	
		(degrees, minutes, seconds)					Land surface	Top of the Minnekahta Limestone ¹
Fall River County—Continued								
9S 6E18CD	431543103272501	431543	1032725	10/27/1964	W	2,692	3,348	1,491
9S 7E16DA	431556103172501	431556	1031725	05/16/1971	W	4,335	3,350	79
9S 7E25AD	431420103115001	431420	1031430	10/03/1958	W	4,617	3,390	-192
10S 1E 3AB	431255103590001	431255	1035900	01/05/1998	W	3,449	3,731	1,124
10S 1E19AC	431008104023301	431008	1040233	05/29/1985	W	3,750	3,865	1,024
10S 1E19AD	431005104021101	431005	1040211	01/18/1985	W	3,750	3,871	1,055
10S 1E19DA	430952104021201	430952	1040212	06/06/1984	W	3,780	3,896	1,056
10S 1E20CBB	430957104020101	430957	1040201	12/23/1984	W	3,750	3,870	1,056
10S 1E32CDB	430759104014301	430759	1040143	02/21/1989	W	3,911	3,968	1,002
10S 1E32DB	430806104012401	430806	1040124	09/20/1985	W	4,005	4,019	1,019
10S 1E34DB	430808103590001	430808	1035900	09/16/1991	W	3,500	3,954	1,334
10S 1E35BDC	430815103580001	430815	1035800	12/20/1995	W	3,473	3,914	1,319
10S 2E 2CA	431233103511001	431233	1035110	04/08/1970	W	3,178	3,660	1,292
10S 2E 3ACDA	431240103453001	431240	1035150	11/26/1943	W	3,855	3,655	1,340
10S 2E 3DAA	431232103513501	431232	1035135	--	W	--	3,655	1,281
10S 2E 4BD	431242103531501	431242	1035315	06/19/1981	W	3,670	3,810	1,398
10S 2E 5BA	431257103543301	431257	1035433	07/03/1990	W	3,340	3,796	1,454
10S 2E10AA	431203103514001	431203	1035140	12/15/1994	W	3,280	3,720	1,291
10S 2E18ACD	431055103552601	431055	1035526	09/01/1989	W	4,065	3,797	1,294
10S 2E18BDB	431100103554401	431100	1035544	07/30/1992	W	3,403	3,792	1,313
10S 2E33DD	430758103524401	430758	1035244	09/07/1986	W	3,870	3,967	1,025
10S 3E16BB	431112103463501	431112	1034635	11/14/1982	W	3,432	3,596	1,124
10S 3E25CD	430836103424801	430836	1034248	11/30/1982	W	3,604	3,506	873
10S 3E28AC	430920103455201	430920	1034552	11/05/1973	W	3,596	3,800	923
10S 3E32DACD	430801103472301	430804	1035647	09/03/1980	X	3,962	3,810	855
10S 4E 4CCA	431218103393001	431218	1033930	12/05/1946	W	3,004	3,475	1,690
10S 4E 8AA	431203103395201	431203	1033952	06/29/1965	W	2,768	3,502	1,705
10S 4E20D	430945103400001	430945	1034000	--/--/1937	W	3,250	3,600	1,910

¹From Carter and Redden, 1999b.

Table 3. Selected data for wells and test holes used in the structure-contour map of the Minnelusa Formation

[NGVD29, National Geodetic Vertical Datum of 1929; W, well; X, test hole; --, no data]

USGS local number	Station identification number	Latitude	Longitude	Date of construction	Type of site	Depth of hole, in feet below land surface	Altitude, in feet above or below (-) NGVD29	
		(degrees, minutes, seconds)					Land surface	Top of the Minnelusa Formation ¹
Butte County								
9N 6E36DA	444147103193501	444147	1031935	10/09/1976	W	5,575	2,804	-1,022
9N 5E24ACA	444350103270701	444350	1032704	07/12/1934	W	4,400	2,860	-1,490
9N 3E27ADBD	444253103440001	444253	1034359	07/--/1952	W	4,016	3,002	672
9N 2E34CDDCA	444129103514801	444129	1035148	10/10/1981	W	3,320	3,185	726
8N 5E12DBC	444002103272001	444002	1032720	12/13/1949	W	5,759	2,880	-749
8N 4E13CD	443857103344801	443857	1033448	01/04/1965	W	2,677	2,930	365
8N 3E33CCB	443627103460301	443625	1034555	11/03/1960	W	--	3,275	1,200
8N 3E31ACA	443655103482001	443650	1034744	08/21/1960	W	1,853	3,190	1,390
8N 3E13AA	443940103412701	443940	1034127	09/16/1991	W	3,750	2,911	920
8N 3E 2DB	444057103425701	444057	1034257	07/25/1960	W	2,240	2,990	880
8N 2E28DDCB	443716103522501	443716	1035225	03/11/1980	W	2,220	3,242	1,642
8N 2E22BBDC	443839103514701	443841	1035201	--/--/1968	W	2,590	3,220	1,240
8N 1E33ABCA	443650104000801	443659	1035958	01/17/1953	W	1,450	3,490	2,255
8N 1E32AD	443648104010001	443648	1040100	--/--/1933	W	1,529	3,500	2,383
8N 1E30ABB	443758104023801	443758	1040238	06/12/1958	W	1,211	3,420	2,278
8N 1E20CACB	443826104012401	443826	1040124	--/--/1953	W	1,321	3,362.1	2,134
8N 1E19CD	443808104025001	443808	1040250	08/27/1959	W	1,214	3,391	2,251
8N 1E19CCCA	443805104031001	443805	1040310	09/19/1957	W	1,142	3,240	2,160
8N 1E19CBA	443818104030001	443818	1040300	10/30/1953	W	1,585	3,406	2,251
8N 1E19ADAC	443836104020801	443837	1040200	05/12/1981	W	1,380	3,340	2,084
7N 2E 6CDBD	443534103552601	443534	1035526	06/13/1980	W	2,180	3,365	2,160
7N 2E 2BBAD	443612103504701	443612	1035047	03/09/1987	W	1,465	3,400	2,020
7N 1E12AAB	443530103565501	443523	1035603	06/30/1962	W	--	3,340	2,500
7N 1E11BCAD	443511103575801	443511	1035758	10/12/1977	W	1,440	3,360	2,494
7N 1E11ACAC	443515103572501	443508	1035730	06/01/1966	W	1,004	3,400	2,496
7N 1E 9CBCB	443500104004801	443500	1040048	09/26/1958	W	785	3,423	2,727
Lawrence County								
7N 4E30DCB	443205103404001	443205	1034040	11/15/1950	W	3,143	3,680	2,176
7N 3E 7AABA	443515103473001	443525	1034732	01/--/1962	W	1,653	3,360	1,778
7N 2E32BDD	443115103540001	443137	1035406	07/13/1981	W	545	3,590	3,130
7N 2E32BB	443427103540201	443153	1035425	10/--/1960	W	540	3,560	3,083
7N 2E32BAC	443117103541301	443147	1035413	11/11/1980	W	500	3,570	3,153
7N 2E31BD	443140103543001	443140	1035525	11/01/1991	W	697	3,580	3,154
7N 2E27CCA	443206103514501	443201	1035145	12/30/1986	W	1,060	3,450	2,760

Table 3. Selected data for wells and test holes used in the structure-contour map of the Minnelusa Formation—Continued

[NGVD29, National Geodetic Vertical Datum of 1929; W, well; X, test hole; --, no data]

USGS local number	Station identification number	Latitude	Longitude	Date of construction	Type of site	Depth of hole, in feet below land surface	Altitude, in feet above or below (-) NGVD29	
		(degrees, minutes, seconds)					Land surface	Top of the Minnelusa Formation ¹
Lawrence County—Continued								
7N 2E24DBDD	443305103485401	443305	1034854	05/14/1981	W	940	3,405	2,480
7N 2E22BCA	443323103515501	443324	1035158	07/14/1960	W	1,218	3,437	2,304
7N 2E21AC	443325103525001	443321	1035238	01/18/1965	W	960	3,440	2,555
7N 2E21AABC	443335103522801	443335	1035228	06/16/1980	W	1,260	3,418	2,498
7N 2E20DA	443310103533501	443310	1035335	11/06/1964	W	1,115	3,390	2,708
7N 2E19CAAAA	443420103551001	443315	1035514	--/--/1960	W	700	3,405	2,764
7N 2E18CA	443355103553001	443359	1035532	--/--/1960	W	845	3,390	2,598
7N 2E15DD	443348103510601	443348	1035127	05/14/1962	W	1,250	3,370	2,191
7N 2E15CC	443330103520301	443348	1035203	--	W	--	3,437	2,320
7N 2E10BADC	443515103513901	443513.1	1035143.4	05/17/1962	W	1,306.5	3,218.1	1,899
7N 1E36DCBC	443117103560101	443114	1035626	06/24/1981	W	500	3,890	3,740
7N 1E36CDDD	443032103562501	443107	1035625	08/02/1977	W	480	3,930	3,775
7N 1E36CDDC	443105103563401	443105	1035634	06/05/1995	W	480	3,930	3,770
7N 1E36BDAA	443141103562301	443142	1035628	--	W	240	3,655	3,447
7N 1E33CCDD	443100104002001	443104.2	1040025.3	07/31/1987	W	1,100	3,667.0	3,246
7N 1E30DDDC	443150104020001	443156	1040205	07/17/1960	W	985	3,510	2,990
7N 1E28CACD	443212104001601	443212	1040016	03/11/1980	W	1,530	3,535	3,225
7N 1E26ACD	443215103573001	443215	1035730	08/18/1960	W	--	3,524	3,327
7N 1E25DBDA	443215103561501	443215	1035610	12/31/1959	W	500	3,510	3,119
7N 1E25CCBC	443202103581101	443205	1035700	04/25/1978	W	240	3,620	3,431
7N 1E23CBDC	443310103582301	443303	1035803	--/--/1954	W	568	3,470	3,035
7N 1E19DCCC	443255104020301	443251	1040233	11/23/1960	W	645	3,520	2,915
7N 1E16ABDB	443430103595401	443430	1035954	06/13/1986	W	600	3,500	2,955
7N 1E14CCDD2	443355103574502	443343	1035802	05/14/1972	W	620	3,474	2,885
6N 4E36CBAA	442610103350001	442616	1033505	05/17/1974	W	460	3,595	3,170
6N 4E35BDCA	442623103360401	442623	1033604	03/20/1988	W	300	3,720	3,521
6N 4E35ADBC	442624103353301	442624	1033533	06/08/1984	W	315	3,560	3,362
6N 4E33ABDC	442708103382001	442630	1033809	07/10/1991	W	460	3,750	3,530
6N 4E31DACD	442606103402301	442606	1034023	11/16/1990	W	730	3,970	3,685
6N 4E31CCBA	442600103411301	442600	1034113	05/06/1985	W	705	4,080	3,915
6N 4E31ADDD	442610103401701	442610	1034017	05/19/1980	W	700	4,040	3,500
6N 4E25BDDDB	442711103345001	442711	1033450	--/--/1974	W	1,200	3,465	2,465
6N 4E22CBCB	442845103363001	442753	1033710	10/--/1924	W	1,020	3,600	3,069
6N 4E21DCBC	442746103381301	442743	1033818	08/15/1977	W	480	3,645	3,230

Table 3. Selected data for wells and test holes used in the structure-contour map of the Minnelusa Formation—Continued

[NGVD29, National Geodetic Vertical Datum of 1929; W, well; X, test hole; --, no data]

USGS local number	Station identification number	Latitude	Longitude	Date of construction	Type of site	Depth of hole, in feet below land surface	Altitude, in feet above or below (-) NGVD29	
		(degrees, minutes, seconds)					Land surface	Top of the Minnelusa Formation ¹
Lawrence County—Continued								
6N 4E21DBCD	442749103381401	442749	1033814	10/13/1961	W	630	3,620	3,241
6N 4E21AC	442807103381101	442807	1033811	05/--/1924	W	957	3,590	3,090
6N 4E16DDBB	442835103380101	442835	1033801	08/25/1986	W	1,442	3,560	2,910
6N 4E16DA	442845103375301	442845	1033753	03/08/1981	W	810	3,620	2,880
6N 3E36DBBB	442622103420601	442622	1034206	03/26/1981	W	165	4,020	3,863
6N 3E35DDBB	442605103424501	442605	1034245	05/03/1986	W	900	4,200	3,988
6N 3E34BB	442640103444501	442640	1034445	10/26/1993	W	922	4,160	3,986
6N 3E26DBBD	442715103432301	442715	1034323	03/10/1976	W	880	3,898	3,678
6N 3E20DDDC	442736103461401	442736	1034614	12/20/1979	W	720	4,020	3,840
6N 3E20BBAD	442825103470401	442825	1034704	08/02/1978	W	460	3,940	3,705
6N 3E20BAAC	442823103465201	442823	1034652	04/02/1993	W	902	3,940	3,707
6N 3E18BDAD	442856103475701	442901	1034757	06/--/1979	W	900	3,900	3,605
6N 3E17ABAA2	442913103465401	442917	1034630	03/22/1976	W	700	3,830	3,265
6N 3E15DDDA	442833103434601	442834.5	1034346.2	06/22/1988	W	320	3,767.5	3,596
6N 3E15BADD	442907103442301	442907	1034423	07/30/1971	W	598	3,840	3,366
6N 3E14BAAB	442837103431401	442918	1034314	06/08/1966	W	280	3,675	3,433
6N 3E10DBBA	442944103441401	442944	1034414	09/03/1988	W	190	3,760	2,845
6N 3E 8DC	442923103463801	442923	1034638	10/17/1992	W	662	3,830	3,273
6N 2E25BBCA	442727103493701	442727	1034937	01/18/1982	W	615	4,105	4,040
6N 2E23DD	442741103495601	442741	1034956	08/20/1977	W	540	4,042	3,882
6N 2E22BCBA	442756103513101	442812	1035206	06/23/1981	W	1,140	4,010	3,880
6N 2E22BBDC	442825103520101	442825	1035201	06/15/1977	W	520	4,000	3,845
6N 2E22BBD	442818103515701	442818	1035157	02/10/1976	W	600	4,060	3,900
6N 2E22ABBD	442821103512501	442821	1035125	08/26/1978	W	480	3,960	3,820
6N 2E20BACA	442820103541001	442820	1035410	09/14/1981	W	200	4,280	4,160
6N 2E20ABAB	442825103535001	442825	1035350	03/15/1971	W	840	4,240	4,100
6N 2E19DABA	442802103544601	442759.6	1035449.2	07/11/1997	W	1,100	4,590.3	4,467
6N 2E16BBBC	442907103530801	442915	1035320	--/--/1979	W	620	3,940	3,735
6N 2E16BA	442917103525601	442917	1035256	05/--/1986	W	760	3,905	3,755
6N 2E16AAB	442918103523001	442918	1035230	07/20/1987	W	925	3,680	3,510
6N 2E15CDDA	442831103513501	442831	1035135	07/08/1978	W	520	3,940	3,835
6N 2E14CBCC	442842103505501	442842	1035055	08/31/1993	W	842	3,760	3,625
6N 2E14CA	442855103503501	442855	1035035	06/01/1987	W	1,180	3,870	3,450
6N 2E14BCCC2	442854103505602	442854.4	1035053.6	08/19/1988	W	68	3,735.4	3,555

Table 3. Selected data for wells and test holes used in the structure-contour map of the Minnelusa Formation—Continued

[NGVD29, National Geodetic Vertical Datum of 1929; W, well; X, test hole; --, no data]

USGS local number	Station identification number	Latitude	Longitude	Date of construction	Type of site	Depth of hole, in feet below land surface	Altitude, in feet above or below (-) NGVD29	
		(degrees, minutes, seconds)					Land surface	Top of the Minnelusa Formation ¹
Lawrence County—Continued								
6N 2E12AD	442956103484001	442956	1034840	09/28/1987	W	500	3,800	3,390
6N 2E 9D	442930103522001	442930	1035220	--	W	300	3,660	3,400
6N 2E 9CAC2	442936103530001	442936	1035300	10/07/1987	W	855	3,762	3,620
6N 2E 9CAC	442935103530301	442935	1035303	05/30/1977	W	205	3,760	3,615
6N 2E 8CCB	442930103543201	442930	1035432	09/--/1980	W	290	3,960	3,710
6N 2E 8AA	443010103533001	443010	1035330	12/18/1989	W	268	3,650	3,370
6N 2E 7DCBA	443026103550401	442932	1035504	10/01/1988	W	220	4,080	3,968
6N 2E 7AAC	443035103544501	443005	1035445	09/10/1986	W	360	3,760	3,465
6N 2E 6DACD	443026103544601	443026	1035446	07/15/1988	W	340	3,720	3,425
6N 2E 6DACC	443025103544501	443028	1035453	06/30/1988	W	267	3,710	3,470
6N 2E 5DC2	443020103525001	443020	1035350	10/15/1988	W	285	3,625	3,375
6N 2E 5CBDB	443035103543001	443035	1035430	11/01/1990	W	290	3,655	3,440
6N 2E 5C	443024103542001	443024	1035420	10/28/1981	W	287	3,650	3,390
6N 2E 5BCAA	443050103541701	443050	1035417	12/--/1979	W	280	3,620	3,380
6N 2E 5BBBB2	443100103543002	443104.3	1035437.7	07/03/1986	W	290	3,677.4	3,275
6N 2E 4DBCC	443028103522801	443033	1035245	02/13/1979	W	420	3,562	3,167
6N 2E 4BBAA	443101103530601	443101	1035306	06/02/1981	W	300	3,548	3,283
6N 1E18BBAA	442917104025801	442917	1040258	10/01/1960	W	300	4,300	4,217
6N 1E16ACBB	442903103595601	442907	1035959	08/05/1964	W	263	4,180	4,089
6N 1E 9ACBC	442953103595601	442953	1035956	10/08/1960	W	189	3,840	3,716
6N 1E 8BCBC	442952104015101	442952	1040151	10/18/1969	W	320	3,900	3,783
6N 1E 6BDAB	443049104024501	443049	1040245	02/--/1977	W	430	3,785	3,570
6N 1E 6ADCD	443039104020901	443039	1040209	--/--/1961	W	315	3,795	3,535
6N 1E 2CABB	443036103575401	443036	1035754	01/20/1982	W	160	3,930	3,810
5N 4E23AABC	442310103353501	442310	1033535	07/14/1974	W	262	3,910	3,875
5N 4E15ADDA	442347103364001	442347	1033640	03/29/1973	W	560	4,075	3,935
5N 4E14BDDC	442348103355801	442348	1033558	--/--/1976	X	560	3,980	3,790
5N 4E14BBDA	442400103362001	442400	1033617	05/21/1981	W	620	4,030	3,832
5N 4E14BA	442542103344701	442400	1033605	04/07/1978	W	380	3,980	3,770
5N 4E14ADA	442340103345001	442348	1033524	--/--/1968	W	400	3,860	3,712
5N 4E13CBAC	442338103350601	442338	1033506	--	W	350	3,815	3,697
5N 4E11CCAD	442416103362301	442412	1033618	08/25/1983	W	75	4,010	3,962
5N 4E 1ABBD2	442545103343702	442544.3	1033437.1	11/30/1990	W	822	3,629.7	3,356
5N 4E 1ABBD	442545103343701	442544.4	1033437.5	06/25/1986	W	300	3,629.3	3,345

Table 3. Selected data for wells and test holes used in the structure-contour map of the Minnelusa Formation—Continued

[NGVD29, National Geodetic Vertical Datum of 1929; W, well; X, test hole; --, no data]

USGS local number	Station identification number	Latitude	Longitude	Date of construction	Type of site	Depth of hole, in feet below land surface	Altitude, in feet above or below (-) NGVD29	
		(degrees, minutes, seconds)					Land surface	Top of the Minnelusa Formation ¹
Lawrence County—Continued								
5N 4E 1ABBC	442546103344101	442546	1033441	01/05/1952	W	310	3,618	3,378
5N 3E 1ADA2	442536103412601	442536	1034126	10/02/1992	W	1,160	4,310	4,140
Meade County								
6N 6E19BCAA	442813103263901	442813	1032639	06/01/1956	W	1,350	3,190	2,655
6N 6E19BBBA	442824103264101	442824	1032641	09/24/1993	W	900	3,200	2,780
6N 5E14ADBD	442901103281601	442901	1032816	10/28/1980	W	1,100	3,100	2,050
5N 5E36DBCB	442058103273001	442058	1032730	08/--/1976	W	1,368	3,720	3,200
5N 5E36ADD	442108103270301	442108	1032703	06/09/1976	W	1,120	3,690	2,675
5N 5E26ABDA	442217103272201	442215	1032829	--/--/1952	W	1,465	3,625	2,882
5N 5E26AA	442215103281701	442215	1032817	06/15/1991	W	1,140	3,605	2,645
5N 5E21AAA	442311103303501	442311	1033035	10/--/1967	W	883	3,600	3,310
5N 5E16DABA	442441103304201	442340	1033042	12/04/1964	W	600	3,570	3,114
5N 5E16CAAD	442335103311001	442336.7	1033111.2	06/16/1986	W	839	3,606.3	3,310
5N 5E 9DCBBA	442416103310301	442419	1033105	--/--/1958	W	744	3,500	3,046
5N 5E 9BCAA	442443103312701	442443	1033127	08/--/1960	W	902	3,530	2,955
5N 5E 9ABCC	442453103310301	442448	1033104	06/03/1955	W	1,060	3,460	2,840
5N 5E 8ACC	442435103321601	442435	1033216	06/08/1994	W	380	3,580	3,245
5N 5E 7ABB4	442455103332804	442455	1033328	05/28/1991	W	340	3,580	3,446
5N 5E 7AAB	442456103330801	442456	1033308	--/--/1971	W	320	3,580	3,390
5N 5E 6AC2	442526103331301	442526	1033313	09/12/1987	W	460	3,550	3,135
5N 5E 5DDC	442502103315701	442502	1033157	--/--/1965	W	508	3,480	2,995
5N 5E 5DCAC	442506103321201	442506	1033212	06/07/1977	W	604	3,498	3,003
5N 5E 5CCCA	442502103325201	442502	1033252	08/10/1977	W	435	3,525	3,208
5N 5E 5BCB	442536103323501	442536	1033252	--/--/1974	W	720	3,555	2,983
5N 5E 4CBCC	442514103314101	442514	1033141	02/28/1984	W	1,497	3,461	2,886
5N 5E 3BCD	442529103301401	442529	1033014	05/15/1992	W	1,740	3,460	1,920
4N 6E32CA	441544103253001	441544	1032530	04/08/1991	W	260	3,640	3,515
4N 6E32BDA	441559103252501	441559	1032525	05/20/1970	W	300	3,631	3,431
4N 6E32BAD	441606103252501	441606	1032525	05/28/1970	W	230	3,620	3,400
4N 6E32ACAB	441609103251901	441604	1032509	10/26/1983	W	340	3,580	3,355
4N 6E30BDA	441648103264001	441648	1032640	06/08/1982	W	540	4,000	3,780
4N 6E30ADCC	441649103262401	441649	1032612	04/05/1979	W	540	3,930	3,770
4N 6E30A	441656103261601	441656	1032616	10/07/1987	W	340	3,860	3,715
4N 6E29BCAD	441641103252001	441651	1032540	10/02/1972	W	190	3,700	3,530

Table 3. Selected data for wells and test holes used in the structure-contour map of the Minnelusa Formation—Continued

[NGVD29, National Geodetic Vertical Datum of 1929; W, well; X, test hole; --, no data]

USGS local number	Station identification number	Latitude	Longitude	Date of construction	Type of site	Depth of hole, in feet below land surface	Altitude, in feet above or below (-) NGVD29		
		(degrees, minutes, seconds)					Land surface	Top of the Minnelusa Formation ¹	
Meade County—Continued									
4N 6E19AABA2	441759103261202	441759.7	1032612.2	11/19/1990	W	840	3,639.1	3,338	
4N 6E16DCB	441812103230501	441812	1032405	01/16/1961	W	1,460	3,460	2,200	
3N 7E31CBBC	441031103195201	441031	1031953	02/19/1976	W	530	3,690	3,400	
3N 7E30CDD	441105103192001	441105	1031920	06/30/1988	W	1,120	3,650	2,670	
3N 7E30BCAD	441147103270001	441138	1031940	10/27/1976	W	1,600	3,870	2,475	
3N 7E19DBDA	441214103191001	441214	1031910	07/04/1970	W	1,653	3,716	2,670	
3N 7E19CDA	441204103192301	441204	1031923	06/08/1950	W	2,155	3,670	2,553	
3N 7E19BDDD	441227103192801	441227	1031928	09/10/1949	W	1,368	3,560	2,640	
3N 7E19AC	441227103191001	441227	1031910	05/30/1950	W	1,235	3,675	2,680	
3N 6E36DD	441017103201001	441017	1032010	05/--/1961	W	210	3,700	3,510	
3N 6E36DB	441029103202201	441029	1032022	08/04/1987	W	338	3,722	3,512	
3N 6E36BDCA	441323103232301	441042	1032040	07/02/1977	W	520	3,780	3,630	
3N 6E36BDB	441039103204901	441039	1032049	07/15/1985	W	400	3,800	3,860	
3N 6E36BDAA	441047103203301	441049	1032031	10/15/1977	W	400	3,720	3,670	
3N 6E36ACB	441052103204801	441052	1032048	09/13/1978	W	420	3,790	3,720	
3N 6E26ACAD	441136103221301	441136	1032128	10/30/1978	W	360	3,680	3,500	
3N 6E25CCDD	441118103210001	441104	1032048	03/25/1985	W	370	3,720	3,495	
3N 6E25ADDA	441131103200101	441131	1032001	11/03/1976	W	805	3,615	2,897	
3N 6E24DBDA	441212103201501	441212	1032015	08/16/1972	W	1,542	3,840	2,463	
3N 6E24CABB	441219103204801	441219	1032048	09/06/1979	W	1,005	3,570	2,735	
3N 6E23DDAC	441202103211301	441207	1032115	07/31/1980	W	860	3,558	3,238	
3N 6E23DCB	441206103213701	441206	1032137	05/09/1980	W	330	3,600	3,340	
3N 6E23DC	441202103213301	441202	1032133	05/15/1987	W	360	3,580	3,362	
3N 6E23DBCA	441211103213701	441211	1032137	01/03/1985	W	375	3,560	3,325	
3N 6E23CADA	441210103215101	441213	1032143	04/26/1983	W	328	3,570	3,510	
3N 6E23CABD	441216103215801	441216	1032158	06/29/1978	W	460	3,700	3,550	
3N 6E16AD2	441322103234202	441322	1032342	07/07/1986	W	260	3,660	3,500	
3N 6E16AD	441322103234201	441322	1032342	09/22/1986	W	340	3,660	3,500	
3N 6E16AAAB	441339103232701	441339	1032327	--	W	295	3,570	3,401	
3N 6E15DABBB	441315103224001	441315	1032236	07/23/1987	W	365	3,530	3,270	
3N 6E15DAA	441257103222501	441257	1032225	06/12/1987	W	263	3,590	3,430	
3N 6E15ABB2	441337103225002	441335.5	1032250.5	08/29/1994	W	880	3,476.8	3,133	
3N 6E15AAAC	441333103222801	441333	1032228	02/15/1979	W	640	3,470	2,980	
3N 6E14CBA	441319103220201	441309	1032208	06/02/1973	W	880	3,485	2,850	

Table 3. Selected data for wells and test holes used in the structure-contour map of the Minnelusa Formation—Continued

[NGVD29, National Geodetic Vertical Datum of 1929; W, well; X, test hole; --, no data]

USGS local number	Station identification number	Latitude	Longitude	Date of construction	Type of site	Depth of hole, in feet below land surface	Altitude, in feet above or below (-) NGVD29	
		(degrees, minutes, seconds)					Land surface	Top of the Minnelusa Formation ¹
Meade County—Continued								
3N 6E 9DDDC	441339103232901	441339	1032329	06/10/1983	W	272	3,660	3,402
3N 6E 9CABB	441358103241801	441358	1032418	10/24/1980	W	260	3,760	3,600
3N 6E 9BCBB2	441421103242302	441421	1032423	08/15/1978	W	365	3,740	3,760
3N 6E 9BBCD	441424103243601	441424	1032436	06/03/1973	W	340	3,780	3,624
3N 6E 4CB	441453103243801	441453	1032438	04/08/1986	W	328	3,570	3,377
3N 6E 3BCBC	441504103230301	441509	1032332	09/04/1979	W	755	3,460	2,810
2N 9E18BAB	440824103050601	440824	1030506	04/17/1942	W	4,645	3,195	-365
2N 8E13BDC	440801103061601	440801	1030616	07/12/1942	--	4,440	3,199	-330
2N 7E10CDCA	440832103160901	440837	1031609	11/19/1956	W	1,048	3,395	2,615
2N 7E 9AABB	440916103163301	440916	1031633	04/11/1979	W	1,260	3,420	2,525
2N 7E 8DDCC	440826103174601	440826	1031746	08/24/1977	W	815	3,600	2,940
2N 7E 8BBC	441636103183801	440907	1031838	05/22/1986	W	1,180	3,530	3,090
2N 7E 7BACA	440908103193101	440906	1031944	01/04/1983	W	480	3,720	3,509
2N 7E 6DCD	440930103190501	440930	1031905	09/--/1959	W	360	3,520	3,308
2N 7E 6CDAC	440936103191801	440926	1031925	01/25/1981	W	340	3,545	3,370
2N 7E 5DDA	440927103173501	440927	1031735	07/06/1988	W	885	3,440	2,690
2N 7E 5CA2	440938103181501	440938	1031815	08/23/1997	W	760	3,480	2,890
2N 7E 4CDDC	440919103170501	440920	1031658	03/--/1959	W	930	3,405	2,650
2N 7E 2DBDD	440939103142001	440939	1031420	04/23/1980	W	2,103	3,375	1,383
2N 7E 2DBDDC	440931103141401	440931	1031414	04/23/1980	W	3,060	3,383	1,383
2N 6E 1AABB	441007103201101	441007	1032011	03/--/1977	W	340	3,725	3,575
Pennington County								
2N 9E29BBCC	440629103040901	440629	1030409	03/18/1983	W	4,450	3,043	-437
2N 7E34CC	440502103160902	440502	1031609	08/01/1995	W	600	3,350	2,780
2N 7E34BDCC2	440524103154001	440524	1031558	06/--/1960	W	1,275	3,325	3,010
2N 7E34BDAD	440528103155201	440528	1031552	06/--/1960	W	585	3,350	2,795
2N 7E34BCCA	440528103161001	440530.9	1031614.2	05/24/1964	W	400	3,328.9	3,105
2N 7E34BAAC	440544103154901	440544	1031549	09/20/1983	W	480	3,380	2,955
2N 7E33BCAA	440534103171401	440534	1031714	05/05/1978	W	225	3,460	3,285
2N 7E 7BACA	440516103175501	440516	1031755	04/05/1982	W	360	3,480	3,180
2N 7E32CDDD	440459103181001	440459	1031810	--/--/1960	W	180	3,480	3,305
2N 7E32CCDC	440458103180101	440458	1031830	06/08/1992	W	661	3,640	3,494
2N 7E32CADA	440532103182001	440516	1031808	09/--/1959	W	310	3,510	3,300
2N 7E32BCCC	440521103184401	440521	1031844	--/--/1951	W	185	3,602	3,537

Table 3. Selected data for wells and test holes used in the structure-contour map of the Minnelusa Formation—Continued

[NGVD29, National Geodetic Vertical Datum of 1929; W, well; X, test hole; --, no data]

USGS local number	Station identification number	Latitude	Longitude	Date of construction	Type of site	Depth of hole, in feet below land surface	Altitude, in feet above or below (-) NGVD29	
		(degrees, minutes, seconds)					Land surface	Top of the Minnelusa Formation ¹
Pennington County—Continued								
2N 7E32ADDD	440526103173001	440526	1031730	02/26/1990	W	1,299	3,440	3,170
2N 7E32ADA	440541103173201	440541	1031732	06/08/1989	W	375	3,600	3,430
2N 7E32AAAC	440545103173501	440545	1031735	08/05/1994	W	300	3,610	3,420
2N 7E32AAA2	440546103173501	440546	1031735	08/19/1992	W	340	3,600	3,420
2N 7E32AAA	440544103173601	440544	1031736	06/--/1977	W	340	3,640	3,475
2N 7E32AA	440543103173901	440543	1031739	07/27/1986	W	240	3,643	3,453
2N 7E31CDCB	440516103194001	440501	1031933	07/10/1972	W	565	3,860	3,818
2N 7E29DDBD2	440556103174801	440556	1031748	09/22/1991	W	320	3,620	3,460
2N 7E29DDB	440557103174401	440557	1031744	04/23/1984	W	308	3,600	3,473
2N 7E29DBD	440605103182801	440605	1031828	08/21/1989	W	330	3,685	3,530
2N 7E29DACB	440606103174701	440606	1031747	11/17/1992	W	349	3,600	3,440
2N 7E29DAC5	440552103173401	440603	1031750	10/16/1985	W	220	3,570	3,427
2N 7E29DAC	440605103174701	440605	1031740	11/17/1992	W	349	3,600	3,440
2N 7E28DACD	440552103162301	440601	1031629	--/--/1959	W	300	3,360	3,175
2N 7E27DABB	440612103152001	440612	1031522	08/12/1991	W	1,787	3,363.1	2,625
2N 7E27CAAB	440607103155901	440613	1031549	07/29/1983	W	615	3,360	2,792
2N 7E27BBCB	440635103161801	440631	1031617	--/--/1961	W	505	3,450	3,045
2N 7E27BBB	440635103161401	440635	1031614	--/--/1961	W	615	3,451	3,041
2N 7E27AABA	440636103152001	440636	1031520	04/--/1959	W	992	3,435	2,655
2N 7E23DACA	440659103140501	440659	1031405	02/08/1991	W	2,680	3,500	1,860
2N 7E20CCCC	440644103183701	440644	1031837	07/21/1961	W	350	3,660	3,475
2N 7E20CAAC	440702103181401	440702	1031814	11/12/1988	W	380	3,580	3,360
2N 7E17DDAA	440736103173701	440736	1031737	--	W	400	3,450	3,194
2N 7E17D	440747103174901	440747	1031749	04/20/1994	W	440	3,460	3,158
2N 7E17BAAD	440818103180801	440819.8	1031809.9	07/03/1984	W	560	3,501.8	3,045
2N 7E16AAB	440823103162701	440823	1031627	08/30/1989	W	1,530	3,400	2,695
1N 9E22BA	440212103012101	440212	1030121	07/15/1952	W	4,185	3,052	-578
1N 8E 9CAB2	440334103095601	440334	1030956	09/--/1990	W	3,805	3,108	468
1N 7E34BAC	440028103160801	440028	1031608	10/03/1985	W	660	3,815	3,405
1N 7E33BAC	440025103170801	440025	1031708	06/29/1994	W	440	3,780	3,480
1N 7E33AABC	440022103163401	440022	1031634	10/20/1983	W	623	3,850	3,490
1N 7E29DBA	440059103175301	440059	1031753	05/24/1990	W	1,430	3,840	3,767
1N 7E28CCC	440038103172601	440038	1031726	08/15/1989	W	600	3,840	3,520
1N 7E27DDAB	440041103151401	440041	1031514	05/--/1962	W	1,320	3,820	2,580

Table 3. Selected data for wells and test holes used in the structure-contour map of the Minnelusa Formation—Continued

[NGVD29, National Geodetic Vertical Datum of 1929; W, well; X, test hole; --, no data]

USGS local number	Station identification number	Latitude	Longitude	Date of construction	Type of site	Depth of hole, in feet below land surface	Altitude, in feet above or below (-) NGVD29	
		(degrees, minutes, seconds)					Land surface	Top of the Minnelusa Formation ¹
Pennington County—Continued								
1N 7E27DADB	440059103154101	440051	1031512	11/20/1970	W	1,430	3,815	2,548
1N 7E26CCAA	440048103145001	440048	1031450	05/02/1984	W	1,460	3,820	2,475
1N 7E26BCDA	440103103144801	440103	1031448	04/06/1984	W	1,545	3,720	2,300
1N 7E23CAB	440149103144301	440149	1031443	06/24/1992	W	1,563	3,810	2,288
1N 7E23BDAB	440203103143601	440203	1031436	--/--/1973	W	1,878	3,840	2,210
1N 7E22DCC	440130103153901	440130	1031539	08/31/1993	W	875	3,780	2,905
1N 7E22CCC	440129103161301	440129	1031613	01/17/1983	W	315	3,650	3,355
1N 7E22BDCC	440158103160401	440155	1031600	11/18/1972	W	445	3,565	3,170
1N 7E22ABCB	440120103153401	440211	1031534	--/--/1960	W	780	3,480	2,798
1N 7E21DBA	440148103164101	440148	1031641	10/11/1985	W	602	3,620	3,464
1N 7E21BDA	440202103165801	440202	1031658	05/23/1985	W	565	3,760	3,605
1N 7E21BCAB	440205103172001	440205	1031720	07/07/1982	W	--	3,900	3,680
1N 7E21BADA	440211103165201	440211	1031703	04/27/1979	W	422	3,650	3,510
1N 7E21ACC	440155103165001	440155	1031650	05/27/1986	W	268	3,660	3,475
1N 7E16DCDC	440220103164001	440220	1031640	12/01/1991	W	1,281	3,486.7	3,339
1N 7E16CCCA	440224103172601	440224	1031726	07/10/1977	W	612	3,800	3,652
1N 7E16CAD	440233103170501	440233	1031705	06/07/1978	W	258	3,580	3,455
1N 7E16BDBB	440247103165401	440247	1031710	05/07/1979	W	235	3,500	3,350
1N 7E16BCC	440249103172701	440249	1031727	07/02/1992	W	317	3,580	3,455
1N 7E16BCB	440255103172601	440255	1031726	12/06/1991	W	200	3,560	3,392
1N 7E16BADA2	440305103164501	440305	1031659	05/15/1979	W	250	3,440	3,250
1N 7E16BAD	440301103165701	440301	1031657	07/03/1985	W	300	3,440	3,240
1N 7E16BACC	440257103171101	440257	1031711	02/07/1973	W	320	3,520	3,365
1N 7E16BAC	440300103170901	440300	1031709	06/20/1984	W	220	3,500	3,340
1N 7E16BAAB	440309103170101	440309	1031701	03/24/1979	W	200	3,430	3,260
1N 7E15CCBC	440223103161701	440229	1031616	--/--/1970	W	500	3,440	3,122
1N 7E15CBBD2	440244103154102	440240	1031612	--	W	460	3,475	3,175
1N 7E15BBC	440302103161401	440302	1031614	03/30/1992	W	430	3,400	3,000
1N 7E15BAD	440244103154301	440302	1031549	--/--/1955	W	921	3,470	2,804
1N 7E14CBCA	440236103145801	440236	1031458	08/23/1973	W	1,660	3,880	2,335
1N 7E14BABD	440308103144301	440305	1031442	03/14/1983	W	1,817	3,833	2,265
1N 7E11DBAD	440331103142701	440237	1031414	11/11/1980	W	1,755	3,560	2,245
1N 7E10CADD	440331103155101	440331	1031551	10/28/1958	W	700	3,410	2,775
1N 7E 6BACB	440446103193201	440446	1031932	07/06/1978	W	850	4,020	3,875

Table 3. Selected data for wells and test holes used in the structure-contour map of the Minnelusa Formation—Continued

[NGVD29, National Geodetic Vertical Datum of 1929; W, well; X, test hole; --, no data]

USGS local number	Station identification number	Latitude	Longitude	Date of construction	Type of site	Depth of hole, in feet below land surface	Altitude, in feet above or below (-) NGVD29	
		(degrees, minutes, seconds)					Land surface	Top of the Minnelusa Formation ¹
Pennington County—Continued								
1N 7E 5BBDB	440447103183101	440447	1031831	05/16/1984	W	500	3,770	3,600
1N 7E 5BBBC	440453103184001	440453	1031840	04/29/1978	W	805	3,780	3,625
1N 7E 5BACA	440445103181601	440445	1031816	04/05/1982	W	360	3,700	3,400
1N 7E 5BAAA	440450103175701	440450	1031810	--/--/1958	W	190	3,560	3,380
1N 7E 4ADAC	440440103162201	440440	1031622	--/--/1960	W	643	3,320	2,920
1N 7E 3CBAA	440430103160201	440427.2	1031605.1	05/24/1964	W	570	3,300	2,900
1N 7E 3CBCB	440436103161201	440436	1031612	02/05/1940	W	635	3,343	2,894
1N 7E 3AAB	444153103151901	440453	1031519	07/--/1941	W	1,385	3,260	2,445
1S 7E 3CDBD2	435916103161802	435915.1	1031620.6	08/05/1994	W	660	3,520.4	2,928
1S 7E11ACAB	435851103143501	435848	1031445	06/10/1984	W	1,740	3,466.2	2,641
1S 7E13BCBA	435720103141601	435739	1031416	10/30/1972	W	1,555	3,780	2,415
1S 7E14CCBB	435733103152801	435733	1031528	--	W	560	3,680	3,160
1S 7E15ABC	435803103160301	435803	1031603	09/10/1987	W	245	3,680	3,463
1S 7E15BD	435753103161601	435753	1031616	10/26/1988	W	345	3,700	3,510
1S 7E15CABA	445809103162201	435744	1031622	06/11/1990	W	430	3,765	3,607
1S 7E15CBBB	435746103160601	435743	1031642	10/26/1977	W	820	3,985	3,812
1S 7E27BACA	435619103161901	435619	1031619	05/30/1978	W	1,280	4,140	3,580
1S 8E19BBBB	435718103130301	435718	1031303	03/08/1984	W	2,600	3,555	1,770
2S 7E 4ACDB	435352103170801	435422	1031711	08/27/1951	W	358	3,800	3,798
2S 7E 9CBDA	435325103171701	435317	1031739	--/--/1960	W	--	3,960	3,785
2S 7E10BAD	435340103161001	435340	1031610	04/22/1992	W	675	3,660	3,031
Custer County								
2S 7E21CCC	435119103175001	435119	1031750	04/28/1993	W	500	3,865	3,730
2S 7E21DDC	435115103170501	435115	1031705	04/09/1981	W	350	3,750	3,570
2S 7E28ADCB	435053103170001	435053	1031700	11/21/1983	W	300	3,760	3,580
2S 7E28ADD	435050103165301	435050	1031653	08/24/1984	W	320	3,740	3,560
2S 7E28DDCB	435028103240601	435028	1031702	06/30/1979	W	309	3,760	3,500
2S 7E34ABBA	435018103155801	435020.3	1031600.3	07/27/1983	W	510	3,477.5	3,022
2S 7E34BCB	435006103163801	435006	1031638	03/31/1989	W	240	3,560	3,375
2S 7E34BDBC	435008103162501	435008	1031625	04/01/1978	W	225	3,500	3,300
3S 7E 5DDCA	434847103175801	434842	1031805	03/01/1990	W	287	3,690	3,440
3S 7E10BADB	434832103161701	434829	1031611	01/01/1976	W	605	3,505	2,924
3S 7E16ACBD	434726103171501	434726	1031715	02/01/1989	W	560	3,590	3,110
3S 7E30DDAC	434500103192201	434519	1031922	11/18/1980	W	280	3,800	3,640

Table 3. Selected data for wells and test holes used in the structure-contour map of the Minnelusa Formation—Continued

[NGVD29, National Geodetic Vertical Datum of 1929; W, well; X, test hole; --, no data]

USGS local number	Station identification number	Latitude	Longitude	Date of construction	Type of site	Depth of hole, in feet below land surface	Altitude, in feet above or below (-) NGVD29	
		(degrees, minutes, seconds)					Land surface	Top of the Minnelusa Formation ¹
Custer County—Continued								
3S 7E33AACB	434502103165801	434502	1031658	--/--/1964	W	1,070	3,655	2,645
4S 6E 1DAAA	434350103201901	434350.8	1032020.2	08/05/1993	W	680	3,860	3,740
4S 7E25CCA	434006103140601	434006	1031406	10/17/1949	W	3,136	3,396	1,096
4S 7E25DDDB	434001103131301	434001	1031313	07/04/1949	W	2,824	3,392	964
4S 8E12AA	434316103061101	434316	1030611	10/25/1980	W	3,773	3,158	-423
5S 1E26CC	433452103582401	433452	1035824	07/24/1961	W	950	4,060	3,615
5S 1E26DC	433452103574801	433452	1035748	12/07/1960	W	901	4,019	3,714
5S 2E28BCCB	433517103534201	433517.4	1035342.3	07/18/1995	W	1,075	4,257.7	4,102
5S 2E30CA	433505103554201	433505	1035542	11/26/1946	W	854	4,332	4,162
6S 1E 1BC	433338103571301	433336	1035713	--/--/1933	W	1,047	4,040	3,899
6S 1E 7DA	433241104021701	433241	1040217	01/06/1977	W	2,328	3,741	2,097
6S 2E 7CAD	433226103553701	433226	1035537	11/13/1958	W	1,201	4,040	3,492
6S 2E 8AA	433254103535201	433254	1035352	08/15/1957	W	1,225	4,088	3,468
6S 2E 9BC	433241103533401	433241	1035334	12/19/1956	W	1,656	4,071.5	3,311
6S 2E14CB	433135103511701	433135	1035117	12/20/1993	W	1,326	4,383	3,503
6S 2E22DD	433030103512701	433030	1035127	06/23/1984	X	1,470	4,190	3,341
6S 2E27CCD	432936103521701	432936	1035217	10/06/1956	W	1,378	4,123	3,428
6S 2E27DB	432952103514601	432952	1035146	10/31/1964	W	1,541	4,126	3,371
6S 2E33AD	432914103524101	432914	1035241	11/04/1958	W	1,454	4,203	3,448
6S 2E34ABC	432923103515001	432923	1035150	11/30/1963	W	1,385	4,133	3,431
6S 2E34BAA	432929103515901	432929	1035159	08/13/1957	W	1,980	4,101	3,417
6S 2E34BDC	432910103520701	432910	1035207	11/02/1963	W	1,931	4,223	3,418
6S 2E34CB	432902103522101	432902	1035221	09/05/1958	W	1,454	4,207	3,412
6S 2E34DBA	432904103514201	432904	1035142	--/--/1956	W	1,650	4,205	3,400
6S 3E25ADDC	433003103420701	433000	1034158	09/05/1976	W	280	4,435	4,416
6S 5E23DB	433034103284701	433044	1032915	06/--/1978	W	820	4,230	4,210
6S 5E24BAAA	433114103281601	433114	1032816	04/13/1977	W	780	4,110	3,970
6S 5E24BC	433026103284501	433056	1032845	06/--/1978	W	680	4,100	4,080
6S 5E25ADD	433513103203201	433003	1032742	--/--/1951	W	580	3,935	3,645
6S 6E15ABDD	433150103230501	433150	1032305	--/--/1949	W	939	3,420	3,432
6S 6E20CA2	433142103232801	433142	1032328	03/--/1924	W	962	3,729	3,392
6S 6E21BBBB	433115103251401	433115.4	1032516.1	10/17/1991	W	1,165	3,645.8	3,210

Table 3. Selected data for wells and test holes used in the structure-contour map of the Minnelusa Formation—Continued

[NGVD29, National Geodetic Vertical Datum of 1929; W, well; X, test hole; --, no data]

USGS local number	Station identification number	Latitude	Longitude	Date of construction	Type of site	Depth of hole, in feet below land surface	Altitude, in feet above or below (-) NGVD29	
		(degrees, minutes, seconds)					Land surface	Top of the Minnelusa Formation ¹
Fall River County								
7S 1E 2DD	432758103572901	432758	1035729	08/19/1964	W	2,450	3,792	2,172
7S 1E11DC	432705103574601	432705	1035746	12/--/1976	W	2,250	3,679	2,129
7S 1E14BA	432652103580501	432652	1035805	12/26/1975	W	2,269	3,639	2,069
7S 1E15DD	432613103584001	432613	1035840	03/05/1965	W	2,264	3,576	1,926
7S 1E21AA	432559103595301	432559	1035953	03/23/1979	W	2,500	3,533	1,750
7S 1E22BC	432547103593501	432547	1035925	11/27/1970	W	2,545	3,534	1,714
7S 1E24CB	432533103570901	432533	1035709	10/06/1964	W	2,480	3,566	2,096
7S 1E33AD	432401103595301	432401	1035953	10/21/1968	W	2,875	3,677	1,657
7S 1E35DD	432336103572701	432336	1035727	07/02/1989	W	2,558	3,555	1,843
7S 2E 2ABB	432834103504001	432834	1035040	06/03/1981	W	1,680	4,121	3,308
7S 2E 2BA	432834103504701	432834	1035047	08/17/1970	W	1,470	4,099	3,329
7S 2E12CC	432702103495901	432702	1034959	11/01/1966	W	1,526	3,983	3,075
7S 2E21ACDC	432546103525801	432540	1035256	09/20/1964	W	2,225	3,810	2,570
7S 2E26ACBA	432453103503601	432458	1035036	12/14/1968	W	2,300	4,160	2,800
7S 2E31AC	432402103552101	432402	1035521	10/03/1968	W	2,340	3,521	1,986
7S 3E 9DD	432703103453401	432703	1034534	05/15/1984	W	1,285	3,919	3,377
7S 3E10CD	432703103445901	432703	1034459	05/30/1969	W	1,248	4,007	3,493
7S 4E10CBB	432725103381101	432725	1033814	10/03/1980	W	200	4,150	4,065
7S 4E10DADC	432717103372501	432706	1033715	11/12/1980	W	120	4,100	4,000
7S 4E19BCCB	432548103414801	432545.8	1034151.2	08/29/1992	W	1,540	4,175.15	3,617
7S 4E19BCCB2	432548103414802	432545.8	1034151.2	12/14/1994	W	710	4,175.1	3,640
7S 4E30DC	432425103410501	432425	1034105	08/26/1965	W	1,680	4,262	3,443
7S 5E14CCCC	432603103295901	432602.7	1032958.7	02/28/1996	W	915	3,715.1	3,557
7S 5E14CCCC2	432603103295902	432602.7	1032958.7	03/19/1996	W	320	3,715.7	3,557
7S 5E14D	432614103290901	432614	1032909	--	W	325	3,500	3,291
7S 5E16BDC2	432636103320101	432636	1033201	12/19/1989	W	360	3,900	3,784
7S 5E20DDD	432521103324301	432511	1033227	07/17/1980	W	450	3,970	3,880
7S 5E22AACB	432553103301501	432553	1033015	07/21/1983	W	400	3,900	3,760
7S 5E22ABC	432558103300601	432550	1033033	04/03/1989	W	480	3,870	3,740
7S 5E27CCA	432437103305701	432437	1033057	05/01/1990	W	350	3,750	3,545
7S 5E29AC	432448103325101	432448	1033251	--/--/1959	W	400	3,960	3,700
7S 5E33DDDB	432331103312001	432331	1033120	11/10/1989	W	460	3,830	3,555
7S 5E34BDC	432352103303601	432352	1033036	08/--/1978	W	523	3,750	3,465
8S 1E12AD	432217103561601	432217	1035616	10/07/1968	W	2,760	3,680	1,714

Table 3. Selected data for wells and test holes used in the structure-contour map of the Minnelusa Formation—Continued

[NGVD29, National Geodetic Vertical Datum of 1929; W, well; X, test hole; --, no data]

USGS local number	Station identification number	Latitude	Longitude	Date of construction	Type of site	Depth of hole, in feet below land surface	Altitude, in feet above or below (-) NGVD29		
		(degrees, minutes, seconds)					Land surface	Top of the Minnelusa Formation ¹	
Fall River County—Continued									
8S 1E31DA	431835104021101	431835	1040211	01/28/1988	X	5,643	3,835	1,029	
8S 2E 2AB	432322103503501	432322	1035035	12/20/1985	W	2,374	3,813	2,243	
8S 2E 8BD	432215103542701	432215	1035427	07/25/1994	W	2,400	3,470	1,804	
8S 2E 8CCCC	432145103545101	432145	1035451	06/18/1994	W	2,450	3,501	1,709	
8S 2E14AD	432123103501701	432124	1035017	12/24/1971	W	2,415	3,623	1,907	
8S 2E14CD	432058103505101	432058	1035051	12/06/1970	W	2,433	3,624	1,900	
8S 2E15AA	432137103512901	432137	1035129	12/30/1964	W	2,472	3,581	1,958	
8S 2E17AB	432141103540901	432141	1035409	07/07/1994	W	2,500	3,502	1,726	
8S 2E17BA	432141103543001	432141	1035430	04/21/1994	W	2,480	3,494	1,711	
8S 2E20CC	432005103544501	432005	1035445	05/16/1981	W	2,900	3,592	1,550	
8S 2E22BC	431845103533701	431845	1035337	--/--/1988	X	2,881	3,610	1,537	
8S 2E23BD	432032103505301	432032	1035053	05/15/1946	W	2,537	3,570	1,870	
8S 2E24BB	432045103495901	432045	1034959	02/05/1958	W	2,545	3,600	1,819	
8S 2E35BD	431835103502301	431848	1035055	06/28/1980	W	2,631	3,469	1,732	
8S 3E 8CCCA	432147103544801	432147	1035448	11/18/1993	W	2,450	3,499	1,714	
8S 3E 8DB	432205103470301	432205	1034703	11/22/1945	W	2,204	3,600	2,222	
8S 3E14AC	432123103432901	432123	1034329	07/20/1968	W	2,425	4,029	2,625	
8S 3E17AB	432137103470301	432137	1034703	08/28/1968	W	2,305	3,650	2,055	
8S 3E17CA	432111103472201	432111	1034722	08/02/1968	W	2,270	3,589	2,009	
8S 3E24DAAC	432020103415801	432020	1034158	08/24/1965	W	1,970	4,033	2,876	
8S 3E30AC	431940103481301	431940	1034813	06/17/1965	W	2,504	3,455	1,809	
8S 3E36BDD	431844103423101	431844	1034231	10/14/1942	W	2,338	4,038	2,788	
8S 4E 6DD	432238103404501	432238	1034045	08/24/1969	X	2,048	4,673	3,149	
8S 4E18DA	432113103405001	432113	1034050	06/12/1981	W	2,296	4,426	2,978	
8S 4E23AC	432030103362301	432030	1033623	05/29/1969	W	2,375	3,990	2,452	
8S 5E 8ABBB	432257103324901	432232	1033259	03/18/1990	W	540	3,995	3,865	
8S 5E16BBAD	432136103321001	432136	1033210	11/20/1987	W	1,140	3,830	3,670	
8S 5E17ACBB	432127103325601	432127	1033256	02/20/1992	W	680	3,900	3,750	
8S 5E20ACC	432025103325401	432025	1033254	01/02/1992	W	320	3,690	3,540	
8S 7E27DCC	431909103161801	431909	1031618	01/24/1946	W	4,548	3,354	-316	
9S 1E 1CABD	431736103565301	431745	1035703	09/23/1971	W	3,300	3,790	1,232	
9S 1E 6BA	431810104025001	431810	1040250	--/--/1983	W	3,670	3,860	985	
9S 1E12ADDC	431704103561801	431701	1035615	12/29/1963	W	3,250	3,831	1,355	
9S 1E23CCAD	431453103582201	431455	1035826	12/27/1968	W	2,743	3,730	1,010	

Table 3. Selected data for wells and test holes used in the structure-contour map of the Minnelusa Formation—Continued

[NGVD29, National Geodetic Vertical Datum of 1929; W, well; X, test hole; --, no data]

USGS local number	Station identification number	Latitude	Longitude	Date of construction	Type of site	Depth of hole, in feet below land surface	Altitude, in feet above or below (-) NGVD29	
		(degrees, minutes, seconds)					Land surface	Top of the Minnelusa Formation ¹
Fall River County—Continued								
9S 1E24BA	431532103565401	431532	1035654	12/15/1986	W	3,335	3,828	1,223
9S 1E29AA	431441104010301	431441	1040103	12/05/1997	W	3,488	3,750	921
9S 1E29BDB	431433104014001	431433	1040140	07/07/1988	W	3,665	3,770	884
9S 1E30DBC	431413104023401	431413	1040234	01/21/1998	W	3,666	3,836	839
9S 2E 1BCDC	431750103500301	431750	1035003	10/23/1936	W	3,183	3,571	1,581
9S 2E 2AC	431756103504201	431756	1035042	08/15/1996	W	2,730	3,598	1,608
9S 2E 2CA	431743103505901	431743	1035059	03/21/1990	W	2,716	3,652	1,560
9S 2E 5CCBD	431729103544901	431729	1035449	11/13/1976	W	3,065	3,822	1,462
9S 2E 6CA	431740103554301	431740	1035543	12/14/1971	W	3,145	3,795	1,425
9S 2E 7ABBB	431718103554201	431723	1035536	12/18/1970	W	3,250	3,877	1,417
9S 2E11AC	431703103504201	431703	1035042	08/09/1996	W	2,700	3,536	1,508
9S 2E12BBAC	431716103500301	431716	1035003	05/--/1981	W	2,898	3,507	1,582
9S 2E14BA	431625103510001	431625	1035100	12/13/1985	W	2,671	3,518	1,466
9S 2E14CD	431545103510001	431545	1035100	04/15/1984	W	2,980	3,580	1,403
9S 2E15ACC	431606103515801	431606	1035158	07/15/1980	W	2,735	3,549	1,478
9S 2E15BA	431622103520601	431622	1035206	08/09/1980	W	2,900	3,636	1,516
9S 2E15CCDB	431543103522801	431543	1035228	09/09/1964	W	3,067	3,575	1,421
9S 2E16AD	432122103524201	431610	1035242	05/30/1981	W	3,347	3,642	1,472
9S 2E16DCCA	431545103530701	431545	1035307	01/22/1969	W	3,095	3,742	1,465
9S 2E20DA	431509103535801	431509	1035410	05/24/1953	W	2,865	3,615	1,465
9S 2E21AC	431515103530501	431515	1035305	06/08/1988	W	2,850	3,570	1,413
9S 2E21BD	431520103532301	431520	1035323	08/21/1987	W	2,847	3,594	1,438
9S 2E21CB	431505103534501	431505	1035345	05/30/1986	W	2,844	3,571	1,430
9S 2E25DC	431400103492601	431400	1034926	02/14/1985	X	3,380	3,807	1,221
9S 2E29AD	431421103535201	431421	1035352	04/21/1982	W	3,050	3,703	1,397
9S 2E30BA	431442103555001	431442	1035550	12/07/1986	W	3,330	3,725	1,167
9S 2E32DB	431316103542301	431316	1035423	02/14/1997	W	3,200	3,727	1,300
9S 2E35CD	431305103505801	431305	1035058	07/18/1983	W	3,380	3,717	1,187
9S 3E25DD	431400103421001	431400	1034210	08/28/1964	W	2,485	3,440	1,990
9S 4E 7BBAC	431715103415301	431718	1034155	05/16/1969	W	2,000	3,966	2,486
9S 5E34ACC	431331103304601	431331	1033046	11/13/1951	W	2,528	3,625	1,787
9S 6E18CD	431543103272501	431543	1032725	10/27/1964	W	2,692	3,348	1,371
9S 7E16DA	431556103172501	431556	1031725	05/16/1971	W	4,335	3,350	-56
9S 7E25AD	431420103115001	431420	1031430	10/03/1958	W	4,617	3,390	-326

Table 3. Selected data for wells and test holes used in the structure-contour map of the Minnelusa Formation—Continued

[NGVD29, National Geodetic Vertical Datum of 1929; W, well; X, test hole; --, no data]

USGS local number	Station identification number	Latitude	Longitude	Date of construction	Type of site	Depth of hole, in feet below land surface	Altitude, in feet above or below (-) NGVD29	
		(degrees, minutes, seconds)					Land surface	Top of the Minnelusa Formation ¹
Fall River County—Continued								
10S 1E 3AB	431255103590001	431255	1035900	01/05/1998	W	3,449	3,731	927
10S 1E19AC	431008104023301	431008	1040233	05/29/1985	W	3,750	3,865	831
10S 1E19AD	431005104021101	431005	1040211	01/18/1985	W	3,750	3,871	861
10S 1E19DA	430952104021201	430952	1040212	06/06/1984	W	3,780	3,896	855
10S 1E20CBB	430957104020101	430957	1040201	12/23/1984	W	3,750	3,870	853
10S 1E32CDB	430759104014301	430759	1040143	02/21/1989	W	3,911	3,968	806
10S 1E32DB	430806104012401	430806	1040124	09/20/1985	W	4,005	4,019	826
10S 1E34DB	430808103590001	430808	1035900	09/16/1991	W	3,500	3,954	1,148
10S 1E35BDC	430815103580001	430815	1035800	12/20/1995	W	3,473	3,914	1,120
10S 2E 3ACDA	431240103453001	431240	1035150	11/26/1943	W	3,855	3,655	1,155
10S 2E 3DAA	431232103513501	431232	1035135	--	W	--	3,655	1,105
10S 2E 4BD	431242103531501	431242	1035315	06/19/1981	W	3,670	3,810	1,254
10S 2E 5BA	431257103543301	431257	1035433	07/03/1990	W	3,340	3,796	1,280
10S 2E10AA	431203103514001	431203	1035140	12/15/1994	W	3,280	3,720	1,107
10S 2E18ACD	431055103552601	431055	1035526	09/01/1989	W	4,065	3,797	1,116
10S 2E18BDB	431100103554401	431100	1035544	07/30/1992	W	3,403	3,792	1,118
10S 2E33DD	430758103524401	430758	1035244	09/07/1986	W	3,870	3,967	805
10S 3E16BB	431112103463501	431112	1034635	11/14/1982	W	3,432	3,596	919
10S 3E25CD	430836103424801	430836	1034248	11/30/1982	W	3,604	3,506	658
10S 3E28AC	430920103455201	430920	1034552	11/05/1973	W	3,596	3,800	811
10S 3E32DACD	430801103472301	430804	1035647	09/03/1980	X	3,962	3,810	760
10S 4E 4CCA	431218103393001	431218	1033930	12/05/1946	W	3,004	3,475	1,475
10S 4E 8AA	431203103395201	431203	1033952	06/29/1965	W	2,768	3,502	1,562
10S 4E20D	430945103400001	430945	1034000	--/--/1937	W	3,250	3,600	1,800

¹From Carter and Redden, 1999c.

Table 4. Selected data for wells and test holes used in the structure-contour map of the Madison Limestone

[NGVD29, National Geodetic Vertical Datum of 1929; W, well; X, test hole; --, no data]

USGS local number	Station identification number	Latitude	Longitude	Date of construction	Type of site	Depth of hole, in feet below land surface	Altitude, in feet above or below (-) NGVD29	
		(degrees, minutes, seconds)					Land surface	Top of the Madison Limestone ¹
Butte County								
9N 6E36DA	444147103193501	444147	1031935	10/09/1976	W	5,575	2,804	-1,606
9N 3E27ADBD	444253103440001	444253	1034359	07/--/1952	W	4,016	3,002	112
9N 2E34CDDCA	444129103514801	444129	1035148	10/10/1981	W	3,320	3,185	355
8N 5E12DBC	444002103272001	444002	1032720	12/13/1949	W	5,759	2,880	-1,340
8N 3E13AA	443940103412701	443940	1034127	09/16/1991	W	3,750	2,911	325
8N 2E28DDCB	443716103522501	443716	1035225	03/11/1980	W	2,220	3,242	1,112
7N 2E 6CDBD	443534103552601	443534	1035526	06/13/1980	W	2,180	3,365	1,635
7N 1E11BCAD	443511103575801	443511	1035758	10/12/1977	W	1,440	3,360	1,980
Lawrence County								
7N 4E30DCB	443205103404001	443205	1034040	11/15/1950	W	3,143	3,680	1,653
7N 1E33CCDD	443100104002001	443104.2	1040025.3	07/31/1987	W	1,100	3,667	2,665
6N 4E22CBCB	442845103363001	442753	1033710	10/--/1924	W	1,020	3,600	2,662
6N 4E21AC	442807103381101	442807	1033811	05/--/1924	W	957	3,590	2,663
6N 3E35DDBB	442605103424501	442605	1034245	05/03/1986	W	900	4,200	3,540
6N 3E33BABC	442637103451901	442637	1034550	04/30/1990	W	760	4,190	3,570
6N 3E29DDDB	442651103460401	442648	1034616	06/28/1978	W	700	4,190	3,670
6N 3E26BDBD	442715103432301	442715	1034323	03/10/1976	W	880	3,898	3,152
6N 3E20DDDC	442736103461401	442736	1034614	12/20/1979	W	720	4,020	3,360
6N 3E20BAAC	442823103465201	442823	1034652	04/02/1993	W	902	3,940	3,080
6N 3E18BDAD	442856103475701	442901	1034757	06/--/1979	W	900	3,900	3,120
6N 3E18BDAD	442856103475701	442901	1034757	06/--/1979	W	900	3,900	3,120
6N 3E18BDAD	442856103475701	442901	1034757	06/--/1979	W	900	3,900	3,120
6N 3E18BDAD	442856103475701	442901	1034757	06/--/1979	W	900	3,900	3,120
6N 3E15DDDA2	442833103434602	442834.0	1034346.2	09/08/1995	W	780	3,768.1	3,040
6N 2E25BBCA	442727103493701	442727	1034937	01/18/1982	W	615	4,105	3,553
6N 2E22CBAB	442757103512901	442802	1035157	09/27/1991	W	870	4,240	3,571
6N 2E22BCBA2	442813103520501	442813	1035205	06/23/1981	W	1,140	4,160	3,375
6N 2E22BCBA	442756103513101	442812	1035206	06/23/1981	W	1,140	4,010	3,308
6N 2E20ABAB	442825103535001	442825	1035350	03/15/1971	W	840	4,240	3,710
6N 2E19DABA	442802103544601	442759.6	1035449.2	07/11/1997	W	1,100	4,590.3	4,005
6N 2E16BDC	442853103530001	442853	1035300	09/--/1977	W	600	3,980	3,420
6N 2E16BBBC	442907103530801	442915	1035320	--/--/1979	W	620	3,940	3,360
6N 2E16BA	442917103525601	442917	1035256	05/--/1986	W	760	3,905	3,285
6N 2E16AAB	442918103523001	442918	1035230	07/20/1987	W	925	3,680	3,120

Table 4. Selected data for wells and test holes used in the structure-contour map of the Madison Limestone—Continued

[NGVD29, National Geodetic Vertical Datum of 1929; W, well; X, test hole; --, no data]

USGS local number	Station identification number	Latitude	Longitude	Date of construction	Type of site	Depth of hole, in feet below land surface	Altitude, in feet above or below (-) NGVD29	
		(degrees, minutes, seconds)					Land surface	Top of the Madison Limestone ¹
Lawrence County—Continued								
6N 2E14CBCC	442842103505501	442842	1035055	08/31/1993	W	842	3,760	3,165
6N 2E14CA	442855103503501	442855	1035007	06/01/1987	W	1,180	3,810	2,995
6N 2E 9CAC2	442936103530001	442936	1035300	10/07/1987	W	855	3,762	3,107
6N 2E 9ADDB	442950103521501	442950	1035220	09/02/1988	W	741	3,640	2,922
5N 4E23ADBA	442259103353101	442259	1033531	09/--/1977	W	560	4,010	3,810
5N 4E22ADDA	442301103365501	442301	1033655	10/15/1997	W	560	4,060	3,820
5N 4E15ABCA	442358103370101	442358	1033701	09/--/1981	W	900	4,260	3,660
5N 4E 1ABBD2	442545103343702	442544.3	1033437.1	11/30/1990	W	822	3,629.7	2,840
5N 3E 1ADA2	442536103412601	442536	1034126	10/02/1992	W	1,160	4,310	3,690
5N 1E11DABA	442435103571101	442434.6	1035710.8	10/17/1995	W	780	5,530.2	5,280
Meade County								
6N 6E19BBDB	442815103263801	442815	1032638	--	W	904	3,180	2,358
6N 6E19BBBA	442824103264101	442824	1032641	09/24/1993	W	900	3,200	2,380
5N 5E36DBCB	442058103273001	442058	1032730	08/--/1976	W	1,368	3,720	2,780
5N 5E26ABDA	442217103272201	442215	1032829	--/--/1952	W	1,465	3,625	2,345
5N 5E16CAAD	442335103311001	442336.7	1033111.2	06/16/1986	W	839	3,606.3	2,868
5N 5E 4CBCC	442514103314101	442514	1033141	02/28/1984	W	1,497	3,461	2,401
4N 6E19AABA2	441759103261202	441759.7	1032612.2	11/19/1990	W	840	3,639.1	2,900
3N 7E19DBDA	441214103191001	441214	1031910	07/04/1970	W	1,653	3,716	2,106
3N 7E19CDA	441204103192301	441204	1031923	06/08/1950	W	2,155	3,670	2,075
3N 6E15ABB2	441337103225002	441335.5	1032250.5	08/29/1994	W	880	3,476.8	2,685
2N 9E18BAB	440824103050601	440824	1030506	04/17/1942	W	4,645	3,195	-1,050
2N 8E13BDC	440801103061601	440801	1030616	07/12/1942	W	4,440	3,199	-1,005
2N 7E 8BBC	441636103183801	440907	1031838	05/22/1986	W	1,180	3,530	2,590
2N 7E 7BACA	440908103193101	440906	1031944	01/04/1983	W	480	3,720	3,219
2N 6E10DD	440828103222601	440828	1032226	07/19/1986	W	380	4,120	3,760
2N 6E 1CCC	440925103210201	440920	1032102	11/15/1991	W	950	4,100	3,780
Pennington County								
2N 9E29BBCC	440629103040901	440629	1030409	03/18/1983	W	4,450	3,043	-1,107
2N 7E34BDCC2	440524103154001	440524	1031558	06/--/1960	W	1,275	3,325	2,436
2N 7E32ADDD	440526103173001	440526	1031730	02/26/1990	W	1,299	3,440	2,616
2N 7E31CCCA	440500103193601	440458	1031950	08/21/1971	W	680	3,974.4	3,360
2N 7E31BCB	440602103194201	440532	1031949	04/12/1985	W	525	3,770	3,497
2N 7E27DABB	440612103152001	440612	1031522	08/12/1991	W	1,787	3,363.1	2,030

Table 4. Selected data for wells and test holes used in the structure-contour map of the Madison Limestone—Continued

[NGVD29, National Geodetic Vertical Datum of 1929; W, well; X, test hole; --, no data]

USGS local number	Station identification number	Latitude	Longitude	Date of construction	Type of site	Depth of hole, in feet below land surface	Altitude, in feet above or below (-) NGVD29	
		(degrees, minutes, seconds)					Land surface	Top of the Madison Limestone ¹
Pennington County—Continued								
2N 7E27ACAB	440622103152701	440625	1031530	12/04/1991	W	1,460	3,400	2,253
2N 7E23DACA	440659103140501	440659	1031405	02/08/1991	W	2,680	3,500	1,226
2N 7E19CDAD	440650103193201	440650	1031932	07/08/1981	W	745	3,990	3,598
2N 7E18BCA	440808103193701	440808	1031937	07/15/1976	W	570	3,920	3,420
2N 7E16AAB	440823103162701	440823	1031627	08/30/1989	W	1,530	3,400	2,250
2N 6E35A	440534103212601	440534	1032126	--/--/1955	W	370	3,980	3,730
2N 6E26BD	440621103215301	440621	1032153	01/26/1995	W	900	4,180	4,030
2N 6E26BAAC	440636103214701	440636	1032147	09/19/1980	W	340	3,950	3,898
2N 6E24CC	440640103205801	440640	1032058	--	W	820	4,310	4,131
2N 6E23DBAB	440658103213001	440704	1032132	12/18/1985	W	420	3,860	3,599
2N 6E15DDB	440744103223401	440744	1032234	03/15/1995	W	407	4,210	4,185
2N 6E15BDB	440804103230501	440804	1032305	--	W	370	4,260	3,925
2N 6E15BC	440810103234401	440804	1032324	02/18/1985	W	505	4,300	4,180
2N 6E15BBBD	440820103232601	440820	1032326	07/27/1992	W	372	4,290	4,230
2N 6E15ADAA	440811103222201	440811.1	1032221.8	12/20/1995	W	425	4,060.7	3,685
2N 6E15AD2	440805103223001	440805	1032230	08/21/1995	W	430	4,160	3,800
2N 6E14CAC	440758103214301	440750	1032201	07/06/1977	W	540	4,150	3,850
1N 8E 9CAB2	440334103095601	440334	1030956	09/--/1990	W	3,805	3,108	-342
1N 7E32DABA	440004103174001	440006	1031742	06/23/1986	W	780	3,999.2	3,335
1N 7E32CADB	435959103181301	435959	1031813	04/12/1978	W	1,170	4,060	3,635
1N 7E31BCAD	440523103194201	440019	1031941	05/11/1978	W	598	4,260	4,125
1N 7E31ABAA	440034103190001	440034	1031900	11/--/1975	W	860	3,990	3,740
1N 7E29DBA	440059103175301	440059	1031753	05/24/1990	W	1,430	3,840	3,190
1N 7E29CADD	440052103181201	440053.6	1031810.4	06/30/1984	W	940	3,859.5	3,460
1N 7E21BCAB	440205103172001	440205	1031720	07/07/1982	W	--	3,900	3,040
1N 7E18DADB	440238103185201	440238	1031852	07/11/1978	W	325	3,620	3,345
1N 7E18BDDD	440247103192501	440247	1031925	03/22/1994	W	220	3,500	3,415
1N 7E18ACCC	440247103191701	440247	1031917	06/12/1993	W	150	3,540	3,440
1N 7E18AAAD	440308103184601	440308.5	1031847.5	10/31/1996	W	200	3,413.8	3,338
1N 7E16DCDC	440220103164001	440220	1031640	12/01/1991	W	1,281	3,486.7	2,663
1N 7E 8DDCD2	440310103173802	440312	1031740	05/08/1991	W	940	3,409.5	2,825
1N 7E 8CCA	440319103182901	440319	1031829	08/03/1985	W	300	3,390	3,099
1N 7E 6DCAB	440416103190701	440416	1031907	09/20/1973	W	800	3,900	3,165
1N 7E 6BACB	440446103193201	440446	1031932	07/06/1978	W	850	4,020	3,240

Table 4. Selected data for wells and test holes used in the structure-contour map of the Madison Limestone—Continued

[NGVD29, National Geodetic Vertical Datum of 1929; W, well; X, test hole; --, no data]

USGS local number	Station identification number	Latitude	Longitude	Date of construction	Type of site	Depth of hole, in feet below land surface	Altitude, in feet above or below (-) NGVD29	
		(degrees, minutes, seconds)					Land surface	Top of the Madison Limestone ¹
Pennington County—Continued								
1N 7E 3BBCC	440446103161701	440444.6	1031618.6	11/08/1989	W	1,391	3,313.8	2,273
1N 7E 1DBBB	440427103131701	440426.6	1031318.0	11/--/1990	W	3,280	3,395.7	560
1N 6E12ADA	440341103200301	440341	1032003	03/09/1990	W	780	4,000	3,713
1N 6E 2ABBB	440429103214301	440454	1032143	05/03/1977	W	540	4,060	4,020
1S 1E33AB	435530104000701	435527	1040010	--	W	475	6,340	5,992
1S 7E 3CDBD2	435916103161802	435915.1	1031620.6	08/05/1994	W	660	3,520.4	2,323
1S 7E 5DCCD	435902103182601	435908	1031824	--	W	1,021	4,060	3,730
1S 7E 6DBCA	435941103195001	435924	1031943	11/10/1985	W	300	4,060	3,950
1S 7E 8ABAA	435903103181301	435903	1031813	--	W	754	4,100	3,680
1S 7E 9CBBD	435835103175001	435835	1031750	03/--/1976	W	1,105	4,110	3,675
1S 7E11ACAB	435851103143501	435848	1031445	06/10/1984	W	1,740	3,466.2	2,066
1S 7E15CBBB	435746103160601	435743	1031642	10/26/1977	W	820	3,985	3,175
1S 7E18ABDAB	445826103193601	435805	1031926	09/--/1960	W	826	4,315	3,985
1S 7E20ACAD	435644103183801	435641.3	1031843.4	08/06/1979	W	1,033	4,171.0	3,645
1S 7E20CAD	435635103181401	435635	1031814	05/09/1983	W	903	4,120	3,608
1S 7E20CBCA	435647103185601	435647	1031856	--/--/1956	W	403	4,180	3,850
1S 7E21BBCC	435709103175301	435709	1031753	06/10/1979	W	1,340	4,060	3,470
1S 7E32ADCD	435611103190101	435511	1031807	11/18/1978	W	360	4,110	3,770
1S 7E32BADCD	435522103183701	435522	1031837	01/13/1977	W	273	4,158	4,088
1S 7E33BDBD	435518103173001	435518	1031730	11/04/1992	W	680	4,090	3,600
1S 8E19BBBB	435718103130301	435718	1031303	03/08/1984	W	2,600	3,555	1,195
2S 7E17CCAA	435227103185301	435227.3	1031852.7	06/29/1995	W	540	3,931.7	3,571
Custer County								
2S 7E28CB2	435042103174402	435042	1031744	09/17/1985	W	375	3,540	3,170
3S 1E18DDDB	434700104021401	434701.7	1040215.5	09/09/1993	W	1,054	4,644.6	3,785
4S 2E 2ABD	434406103503301	434406	1035033	01/04/1985	W	810	5,400	5,360
4S 2E 2ADB	434402103502301	434402	1035023	08/25/1959	W	700	5,430	5,427
4S 3E 4BBDB	434407103461401	434408	1034626	07/24/1980	W	675	5,660	5,490
4S 6E 1DAAA	434350103201901	434350.8	1032020.2	08/05/1993	W	680	3,860	3,260
5S 2E28BCCB	433517103534201	433517.4	1035342.3	07/18/1995	W	1,075	4,257.7	3,245
5S 4E18DDDD	433630103404601	433630	1034046	09/12/1996	X	630	4,945	4,880
6S 2E 9BC	433241103533401	433241	1035334	12/19/1956	W	1,656	4,071.5	2,691
6S 5E23DB	433034103284701	433044	1032915	06/--/1978	W	820	4,230	3,620
6S 5E24BAAA	433114103281601	433114	1032816	04/13/1977	W	780	4,110	3,420

Table 4. Selected data for wells and test holes used in the structure-contour map of the Madison Limestone—Continued

[NGVD29, National Geodetic Vertical Datum of 1929; W, well; X, test hole; --, no data]

USGS local number	Station identification number	Latitude	Longitude	Date of construction	Type of site	Depth of hole, in feet below land surface	Altitude, in feet above or below (-) NGVD29	
		(degrees, minutes, seconds)					Land surface	Top of the Madison Limestone ¹
Custer County—Continued								
6S 6E 6DDA	433311103263101	433311	1032631	03/30/1956	W	795	3,809	3,337
6S 6E15ABDD	433150103230501	433150	1032305	--/--/1949	W	939	3,420	2,581
6S 6E20CA2	433142103232801	433142	1032328	03/--/1924	W	962	3,729	2,729
6S 6E21BBBB	433115103251401	433115.4	1032516.1	10/17/1991	W	1,165	3,645.8	2,590
Fall River County								
7S 3E36DCD	432340103421501	432340	1034215	--	W	--	4,130	2,020
7S 4E19BCCB	432548103414801	432545.8	1034151.2	08/29/1992	W	1,540	4,175.15	2,643
7S 5E14CCCC	432603103295901	432602.7	1032958.7	02/28/1996	W	915	3,715.1	2,850
8S 5E16BBAD	432136103321001	432136	1033210	11/20/1987	W	1,140	3,830	2,740
8S 7E27DCC	431909103161801	431909	1031618	01/24/1946	W	4,548	3,354	-1,100
9S 2E 1ACDB	431753103492601	431753	1034926	03/20/1913	W	2,983	3,455	535
9S 2E 1BCDC	431750103500301	431750	1035003	10/23/1936	W	3,183	3,571	406
9S 7E16DA	431556103172501	431556	1031725	05/16/1971	W	4,335	3,350	-850
9S 7E25AD	431420103115001	431420	1031430	10/03/1958	W	4,617	3,390	-1,135
10S 2E 3ACDA	431240103453001	431240	1035150	11/26/1943	W	3,855	3,655	95
10S 2E 3DAA	431232103513501	431232	1035135	--	W	--	3,655	55
10S 2E 4BD	431242103531501	431242	1035315	06/19/1981	W	3,670	3,810	150
10S 2E18ACD	431055103552601	431055	1035526	09/01/1989	W	4,065	3,797	18
10S 4E 4CCA	431218103393001	431218	1033930	12/05/1946	W	3,004	3,475	655
10S 4E20D	430945103400001	430945	1034000	--/--/1937	W	3,250	3,600	780

¹From Carter and Redden, 1999d.

Table 5. Selected data for wells and test holes used in the structure-contour map of the Deadwood Formation

[NGVD29, National Geodetic Vertical Datum of 1929; W, well; X, test hole; --, no data]

USGS local number	Station identification number	Latitude	Longitude	Date of construction	Type of site	Depth of hole, in feet below land surface	Altitude, in feet above or below (-) NGVD29	
		(degrees, minutes, seconds)					Land surface	Top of the Deadwood Formation ¹
Butte County								
9N 3E27ADBD	444253103440001	444253	1034359	07/--/1952	W	4,016	3,002	-1,002
8N 5E12DBC	444002103272001	444002	1032720	12/13/1949	W	5,759	2,880	-2,570
8N 3E13AA	443940103412701	443940	1034127	09/16/1991	W	3,750	2,911	-743
Lawrence County								
7N 4E30DCB	443205103404001	443205	1034040	11/15/1950	W	3,143	3,680	710
5N 4E18CDAB	442326103405101	442326	1034051	07/24/1991	W	1,045	4,740	4,180
5N 3E14ACAD	442351103425201	442351	1034252	10/22/1979	W	1,061	4,860	4,210
4N 2E20BBAC2	441757103544602	441757.5	1035445.5	10/09/1996	W	780	6,209.8	5,592
Meade County								
3N 7E19CDA	441204103192301	441204	1031923	06/08/1950	W	2,155	3,670	1,520
2N 6E 1CCC	440925103210201	440920	1032102	11/15/1991	W	950	4,100	3,200
Pennington County								
2N 6E35CBBC	440520103221501	440515	1032215	01/23/1992	W	602	4,240	3,680
2N 6E26BD	440621103215301	440621	1032153	01/26/1995	W	900	4,180	3,330
2N 6E26BD	440621103215301	440621	1032153	01/26/1995	W	900	4,180	3,330
2N 6E26BD	440621103215301	440621	1032153	01/26/1995	W	900	4,180	3,330
2N 6E26BD	440621103215301	440621	1032153	01/26/1995	W	900	4,180	3,330
2N 6E24CC	440640103205801	440640	1032058	--	W	820	4,310	3,580
2N 6E18DC	440738103262301	440738	1032623	05/04/1985	W	--	4,860	4,830
2N 6E15ADAA	440811103222201	440811.1	1032221.8	12/20/1995	W	425	4,060.7	3,190
2N 1E27ADAC	440623103583701	440626.8	1035835.9	09/18/1991	W	450	6,883.7	6,465
1N 7E32CADB	435959103181301	435959	1031813	04/12/1978	W	1,170	4,060	2,972
1N 7E31DDB	435953103185701	435953	1031857	08/23/1994	W	940	4,060	3,140
1N 7E31CDC	435945103193301	435945	1031933	08/20/1994	W	940	4,020	3,102
1N 7E31BCA	440018103194101	440018	1031941	05/26/1995	W	1,155	4,260	3,170
1N 7E31ABAA	440034103190001	440034	1031900	11/--/1975	W	860	3,990	3,175
1N 7E29DBA	440059103175301	440059	1031753	05/24/1990	W	1,430	3,840	2,770
1N 7E29CADD	440052103181201	440053.6	1031810.4	06/30/1984	W	940	3,859.5	2,987
1N 6E36BCA	440018103205401	440018	1032054	08/01/1986	W	500	4,260	4,010
1N 6E35AADD	440023103211001	440022.9	1032110.2	07/02/1996	W	375	4,227.5	4,167
1N 6E13BADB	440304103203501	440304	1032035	06/03/1993	W	815	4,040	3,510
1N 6E13BABC	440302103204401	440302	1032044	01/22/1995	W	670	4,060	3,660
1N 6E13AA	440306103195701	440306	1031957	09/23/1988	W	560	3,740	3,215
1N 6E12CC	440319103205801	440319	1032058	08/20/1994	W	680	4,100	3,460
1N 6E12ADA	440341103200301	440341	1032003	03/09/1990	W	780	4,000	3,292
1N 6E11DBDA	440329103212801	440329	1032128	10/03/1990	W	700	4,180	3,600

Table 5. Selected data for wells and test holes used in the structure-contour map of the Deadwood Formation—Continued

[NGVD29, National Geodetic Vertical Datum of 1929; W, well; X, test hole; --, no data]

USGS local number	Station identification number	Latitude	Longitude	Date of construction	Type of site	Depth of hole, in feet below land surface	Altitude, in feet above or below (-) NGVD29	
		(degrees, minutes, seconds)					Land surface	Top of the Deadwood Formation ¹
Pennington County—Continued								
1N 6E 2BBB	440454103221201	440454	1032212	09/26/1985	W	500	4,160	3,727
1N 6E 2BAC	440445103220001	440445	1032200	12/--/1971	W	560	4,160	3,715
1N 6E 2ABBB	440429103214301	440454	1032143	05/03/1977	W	540	4,060	3,530
1S 7E 7ACA	435850103193001	435850	1031930	12/30/1985	W	845	4,260	3,720
1S 7E 7CBAB	435838103200901	435838	1032009	03/05/1979	W	620	4,190	3,860
1S 7E 8ABBD	435900103182401	435900	1031824	--	W	840	4,100	3,360
1S 7E 9CBBD	435835103175001	435835	1031750	03/--/1976	W	1,105	4,110	3,330
1S 7E18ABDAB	445826103193601	435805	1031926	09/--/1960	W	826	4,315	3,585
1S 7E20ACAD	435644103183801	435641.3	1031843.4	08/06/1979	W	1,033	4,171.0	3,340
1S 7E21BBCC	435709103175301	435709	1031753	06/10/1979	W	1,340	4,060	3,140
2S 7E18DCBC	435206103194001	435215	1031938	03/12/1979	W	377	4,020	3,898
Custer County								
4S 2E 2ABD	434406103503301	434406	1035033	01/04/1985	W	810	5,400	4,905
4S 2E 2ADB	434402103502301	434402	1035023	08/25/1959	W	700	5,430	4,945
4S 2E 7B	434322103555501	434322	1035555	08/20/1985	W	1,080	5,110	4,165
5S 4E16DB	433650103384501	433650	1033845	--/--/1959	W	380	5,090	4,920
5S 4E18DDDD	433630103404601	433630	1034046	09/12/1996	X	630	4,945	4,462
5S 4E23BA	433623103364101	433623	1033641	--/--/1955	W	360	4,885	4,651
5S 5E31BDDB	433423103341301	433423	1033413	01/29/1973	W	36	4,630	4,620
6S 4E10DCDB	433912103373501	433212	1033735	08/12/1983	W	900	4,740	4,050
6S 6E 6DDA	433311103263101	433311	1032631	03/30/1956	W	795	3,809	3,049
6S 6E20CA2	433142103232801	433142	1032328	03/--/1924	W	962	3,729	2,429
Fall River County								
10S 2E 3DAA	431232103513501	431232	1035135	--	W	--	3,655	-235
10S 2E18ACD	431055103552601	431055	1035526	09/01/1989	W	4,065	3,797	-252

¹From Carter and Redden, 1999e.