



NAVAL POSTGRADUATE SCHOOL

MONTEREY, CALIFORNIA

THESIS

**VALIDATION OF THE USNTPS SIMULATOR FOR THE
ADVANCED FLIGHT CONTROLS DESIGN EXERCISE**

by

Daniel S. Jurta Sr.

December 2005

Thesis Advisor:
Second Reader:

Isaac Kaminer
Mark Rhoades

Approved for public release; distribution is unlimited

THIS PAGE INTENTIONALLY LEFT BLANK

REPORT DOCUMENTATION PAGE			Form Approved OMB No. 0704-0188	
Public reporting burden for this collection of information is estimated to average 1 hour per response, including the time for reviewing instruction, searching existing data sources, gathering and maintaining the data needed, and completing and reviewing the collection of information. Send comments regarding this burden estimate or any other aspect of this collection of information, including suggestions for reducing this burden, to Washington headquarters Services, Directorate for Information Operations and Reports, 1215 Jefferson Davis Highway, Suite 1204, Arlington, VA 22202-4302, and to the Office of Management and Budget, Paperwork Reduction Project (0704-0188) Washington DC 20503.				
1. AGENCY USE ONLY (Leave blank)		2. REPORT DATE December 2005	3. REPORT TYPE AND DATES COVERED Master's Thesis	
4. TITLE AND SUBTITLE: Validation of the USNTPS Simulator for the Advanced Flight Controls Design Exercise			5. FUNDING NUMBERS	
6. AUTHOR Jurta, Daniel S Sr.				
7. PERFORMING ORGANIZATION NAME(S) AND ADDRESS(ES) Naval Postgraduate School Monterey, CA 93943-5000			8. PERFORMING ORGANIZATION REPORT NUMBER	
9. SPONSORING /MONITORING AGENCY NAME(S) AND ADDRESS(ES) US Naval Test Pilot School			10. SPONSORING/MONITORING AGENCY REPORT NUMBER	
11. SUPPLEMENTARY NOTES The views expressed in this thesis are those of the author and do not reflect the official policy or position of the Department of Defense or the U.S. Government.				
12a. DISTRIBUTION / AVAILABILITY STATEMENT Approved for public release; distribution is unlimited			12b. DISTRIBUTION CODE	
13. ABSTRACT (maximum 200 words) This thesis explores the fidelity of the ground based simulator used at USNTPS during the Advanced Flight Controls Design exercise. A Simulink model is developed as a test platform and used to compare the longitudinal flight characteristics of the simulator. The model is also compared to the same characteristics of a Learjet in the approach configuration. The Simulink model is modified with the aim of yielding a better training aid for the students as well as providing a means of comparison between the simulator flight data and the actual Learjet flight data. Open loop and closed loop trials are completed to gather data for analysis and improvement of the Simulink model. Regression analysis is also performed on the flight data as a means of comparing the longitudinal stability coefficients.				
14. SUBJECT TERMS Simulator Validation, Longitudinal Stability, Regression Analysis			15. NUMBER OF PAGES 73	
			16. PRICE CODE	
17. SECURITY CLASSIFICATION OF REPORT Unclassified	18. SECURITY CLASSIFICATION OF THIS PAGE Unclassified	19. SECURITY CLASSIFICATION OF ABSTRACT Unclassified	20. LIMITATION OF ABSTRACT UL	

THIS PAGE INTENTIONALLY LEFT BLANK

Approved for public release; distribution is unlimited

**VALIDATION OF THE USNTPS SIMULATOR FOR THE ADVANCED FLIGHT
CONTROLS DESIGN EXERCISE**

Daniel S Jurta Sr.
Lieutenant Commander, United States Navy
B.S., United States Naval Academy, 1995

Submitted in partial fulfillment of the
requirements for the degree of

MASTER OF SCIENCE IN AERONAUTICAL ENGINEERING

from the

**NAVAL POSTGRADUATE SCHOOL
December 2005**

Author: Daniel S Jurta Sr.

Approved by: Isaac Kaminer
Thesis Advisor

Mark Rhoades
Second Reader

Anthony Healey
Chairman, Department of Mechanical and Astronautical
Engineering

THIS PAGE INTENTIONALLY LEFT BLANK

ABSTRACT

This thesis explores the fidelity of the ground based simulator used at USNTPS during the Advanced Flight Controls Design exercise. A Simulink model is developed as a test platform and used to compare the longitudinal flight characteristics of the simulator. The model is also compared to the same characteristics of a Learjet in the approach configuration. The Simulink model is modified with the aim of yielding a better training aid for the students as well as providing a means of comparison between the simulator flight data and the actual Learjet flight data. Open loop and closed loop trials are completed to gather data for analysis and improvement of the Simulink model. Regression analysis is also performed on the flight data as a means of comparing the longitudinal stability coefficients.

THIS PAGE INTENTIONALLY LEFT BLANK

TABLE OF CONTENTS

I.	INTRODUCTION.....	1
II.	SPECIFICATION COMPLIANCE	3
	A. MILITARY REQUIREMENTS.....	3
	1. Classification	3
	2. Flight Phase Category.....	3
	3. Levels and Qualitative Suitability of Flying Qualities.....	4
	B. CONTROL ANTICIPATION PARAMETER.....	4
	C. SHORT PERIOD DAMPING RATIO	6
	D. AFCD SPECIFICATION COMPLIANCE.....	6
III.	FLIGHT SIMULATION.....	9
	A. SIMULATOR HARDWARE.....	9
	B. SIMULATOR SOFTWARE	11
IV.	LEARJET DESCRIPTION	13
	A. GENERAL.....	13
	B. COCKPIT	14
	C. VARIABLE STABILITY SYSTEM	15
	D. DATA RECORDING	16
V.	SIMULINK MODELING	17
	A. SIMULINK DISCUSSION	17
	B. SIMULINK MODEL INITIAL DEVELOPMENT.....	17
VI.	OPEN LOOP CHARACTERISTICS	21
	A. BASELINE RESPONSE	21
	1. Simulator Data	21
	2. Simulink Data.....	22
	3. Data Comparison	23
	B. IMPULSE RESPONSE	26
	1. Simulator Data	26
	2. Simulink Data.....	26
	3. Data Comparison	26
	C. ADDITIONAL ANALYSIS	29
	D. LEARJET DATA.....	30
VII.	CLOSED LOOP TIME DOMAIN MODEL COMPARISON	33
	A. FLIGHT TEST CONDITIONS AND TECHNIQUES.....	33
	B. LEARJET RESPONSE MODELING	34
	C. BLOCK DIAGRAM MODIFICATION.....	34
	D. ANGLE OF ATTACK RESULTS	35
	E. ELEVATOR POSITION RESULTS	38
VIII.	EQUATIONS OF MOTION.....	41

A.	ASSUMPTIONS.....	41
B.	DEVELOPMENT OF EQUATIONS.....	41
IX.	REGRESSION ANALYSIS	45
A.	REGRESSION THEORY	45
B.	METHOD	45
C.	RESULTS	46
D.	DISCUSSION	51
X.	CONCLUSIONS AND RECOMMENDATIONS.....	53
	LIST OF REFERENCES.....	55
	INITIAL DISTRIBUTION LIST	57

LIST OF FIGURES

Figure 1.	S-Plane Graph of CAP Specification Limits [Ref. 7]	7
Figure 2.	Profile of Flight Simulator	9
Figure 3.	Cockpit View of Simulator	10
Figure 4.	OTWV and HDD View of Simulator	10
Figure 5.	Learjet	13
Figure 6.	Left and Right Instrument Panels	14
Figure 7.	VSS Controller Cockpit View	15
Figure 8.	Variable Stability System Block Diagram	16
Figure 9.	AFCO Simulink Model	18
Figure 10.	Elevator Deflection vs. Stick Position Gradient	19
Figure 11.	Simulink Command Gain Determination	20
Figure 12.	Revised Open Loop Model	23
Figure 13.	Open Loop α Response Comparison	24
Figure 14.	Semi-log Plot for Slope and Real Root Comparison	25
Figure 15.	Open Loop α Response to an Aft Stick Impulse	27
Figure 16.	Simulink Model α Error for an Aft Stick Impulse	28
Figure 17.	Semi-log Plot for Slope and Real Root Comparison	29
Figure 18.	Learjet Response Modeling Block Diagram	34
Figure 19.	Updated Closed Loop Simulink Model	35
Figure 20.	AOA Traces of Simulink and the Learjet	36
Figure 21.	Corrected Learjet and Simulink AOA Traces	37
Figure 22.	Elevator Displacement Traces of Simulink and the Learjet	38
Figure 23.	Bode Plot of Elevator Deflection	39
Figure 24.	Regression Results for M_q Parameter Identification	47
Figure 25.	Regression Results for M_α Parameter Identification	48
Figure 26.	Regression Results for M_{δ_e} Parameter Identification	49

THIS PAGE INTENTIONALLY LEFT BLANK

LIST OF TABLES

Table 1.	Class IV, Category C, Level 1 Short Period Dynamic Requirements	6
Table 2.	Initial Conditions and Stability Derivatives for Open Loop Test.....	21
Table 3.	Longitudinal Stability Derivative Comparison.....	30
Table 4.	Dimensionless Coefficient Comparison	51

THIS PAGE INTENTIONALLY LEFT BLANK

ACKNOWLEDGMENTS

I'd like to thank the following for their contributions:

The staff at USNTPS for their assistance, particularly the help of Dr. Vernon Gordon and Mr. Robert Miller, and the pilots and engineers at Veridian for their time and insight.

Most importantly I wish to thank my wife Beverly and my family who have supported me in this endeavor even when it took priority over them.

THIS PAGE INTENTIONALLY LEFT BLANK

I. INTRODUCTION

During their course of study, students at the United States Naval Test Pilot School (USNTPS) complete an Advanced Flight Controls Design (AFCD) exercise as a practical application of previously studied stability and control fundamentals. The design portion of this exercise utilizes a Fortran-based flight simulator that is programmed to be representative of a present day fighter aircraft. To improve the maneuvering capability of modern fighters, most are designed to be statically unstable. The baseline simulator model reflects this and is designed to be unstable in the longitudinal axis. The AFCD exercise requirement is to stabilize the model through the use of pitch rate feedback and angle of attack feedback. Students are challenged to balance adequate stability and sufficient maneuverability to provide acceptable flying qualities. The initial qualitative measure of success is completion of a simulated approach and landing with a tolerable pilot workload.

Once a satisfactory design is achieved, the feedback parameters of the modified simulator model are input into a Learjet with a Variable Stability Simulator (VSS). The VSS modifies the apparent flying qualities of the baseline Learjet to be representative of the student's modified aircraft model. This allows the student to validate his model under actual flight conditions and to further refine the feedback loops. The student then flies the aircraft in the modified configuration and collects data while completing a series of standard longitudinal stability evaluation maneuvers.

This thesis explored the use of the simulator as a training tool for this exercise and its validity as an accurate model of the VSS Learjet. The goal was to provide the most effective training tool for use by USNTPS students during the AFCD exercise.

THIS PAGE INTENTIONALLY LEFT BLANK

II. SPECIFICATION COMPLIANCE

A. MILITARY REQUIREMENTS

The development and procurement of military aircraft references a set of specifications to determine suitability of the design to accomplish the intended mission. These standards are not completely definitive in that a failure to meet a specification does not necessarily make the aircraft unsuitable, but they are the guidelines used by the military.

The specifications are set down in the MIL-STD-1797A Military Standard Flying Qualities of Piloted Vehicles. Per the scope of the document, "It is intended to assure flying qualities for adequate mission performance and flight safety regardless of the design implementation or flight control system augmentation." [Ref. 1] Each specification depends greatly on the context of the test. The MIL-STD-1797A document categorizes aircraft specification compliance based on three basic designations described as follows.

1. Classification

The first designation is the classification of aircraft. All aircraft are given a classification of 1-4, usually denoted in roman numerals. An aircraft's classification is determined by its type as well as its intended mission. Specifications have different ranges of acceptable values based on classification. For example, short-term pitch response to longitudinal inputs for a fighter can be very different from the response for a transport aircraft. The specifications have different tolerances to account for the different aircraft types. The AFCD aircraft examined in this thesis was a fighter and was considered to be class IV for military specification purposes.

2. Flight Phase Category

Aircraft handling qualities are based on the workload required within the context of a given task. This context, called the flight phase category, is the second specification

compliance designation used in the MIL-STD-1797A and is denoted with an A, B or C. As another example, the minimum short period frequency while flying straight and level is less than that required during landing evolutions. Each flight phase category has different specification limits to reflect the different relative workloads and tolerances required during different tasks or portions of the mission. The AFCD aircraft examined in this thesis was evaluated in the context of conducting approaches and landings. This put the aircraft in flight phase category C, also called the Terminal Flight Phase.

3. Levels and Qualitative Suitability of Flying Qualities

The last specification compliance designation is a level rating of 1-3. The three levels denote qualitative flying qualities of a given aircraft and are labeled as Satisfactory, Acceptable, and Controllable. The level system is based on the Cooper-Harper handling qualities ratings [Ref. 2], an aviation industry standard used by USNTPS and in flight test. This parameter provides the context of how stringent the specifications need to be for a given flight task. In general, the specification tolerances for level 2 are less exacting than for level 1 and the limits for level 3 are even more relaxed. In most cases specifications are based on level 1, but levels 2 and 3 are often used for failure modes of different components of the aircraft. The AFCD aircraft examined in this thesis was evaluated using level 1 criteria.

B. CONTROL ANTICIPATION PARAMETER

The AFCD exercise uses the control anticipation parameter (CAP) as the primary reference for short-term pitch response. Since CAP is the specification used in the MIL-STD-1797A to measure the suitability of short period dynamics, this parameter was chosen as the metric for students to evaluate their designs against. CAP is defined as follows [Ref. 1]:

$$CAP = \frac{\omega_{sp}^2}{n_z / \alpha} \quad (1)$$

where

$\omega_{sp} \equiv$ short period frequency (radians)

$n_z \equiv$ normal acceleration load factor

$\alpha \equiv$ angle of attack (radians)

The n_z and α values should be represented as Δn_z and $\Delta \alpha$ but the delta symbols are generally dropped for convenience. The MIL-STD-1797A has defined CAP as shown above which will be the definition used here. Control anticipation parameter qualitatively is a measure of the predictability of the aircraft response to control inputs. Quantitatively, CAP is approximately equal to the ratio of initial pitching acceleration to steady-state normal acceleration [Ref. 3].

The value of n_z/α was not available but was derived as follows for a desired straight and level unaccelerated flight path.

Given the equilibrium flight condition [Ref. 4]:

$$L = n_z W \quad (2)$$

$$\frac{1}{2} \rho V^2 S [C_{L_0} + C_{L_\alpha} \cdot \alpha] = n_z W \quad (3)$$

$$n_z = \frac{\rho V^2 S [C_{L_0} + C_{L_\alpha} \cdot \alpha]}{2W} \quad (4)$$

where

L □ aerodynamic lift

W □ aircraft gross weight

□ □ air density

V □ aircraft velocity

S □ wing area

C_{L_0} □ lift coefficient at zero angle of attack

C_{L_α} □ lift curve slope

taking the partial derivative with respect to □:

$$\frac{\partial n_z}{\partial \alpha} = \frac{\rho V^2 SC_{L\alpha}}{2W} \quad (5)$$

Using standard sea level and a flight condition of 11,500 lb cruising at 125 KTAS, computation yielded an n_z/α value of 4.67. This also assumed a lift curve slope of 4.376, a published value obtained from Veridian [Ref. 5], the company that contracts out the usage of the Learjet to the school.

C. SHORT PERIOD DAMPING RATIO

The short period damping ratio (ζ_{sp}) is commonly defined as the ratio of actual damping to the value that would make the system critically damped. CAP, along with the damping ratio are the two parameters that define the short period dynamic requirements found in MIL-STD-1797A.

D. AFCD SPECIFICATION COMPLIANCE

The specifications for the AFCD exercise are listed in Table 1 [Ref. 6].

	Minimum	Maximum	Units
CAP	0.16	3.6	$\frac{1}{g \cdot \text{sec}^2}$
ω_{sp}	0.87	---	rad/sec
ζ_{sp}	0.35	1.3	---

Table 1. Class IV, Category C, Level 1 Short Period Dynamic Requirements

To ensure compliance with these specifications, the students have two parameters that they may control in the design; pitch rate feedback gain (K_q) and angle of attack feedback gain (K_α). Figure 1 depicts an S-plane representation of the relationship between the gain values and the specification limits. The lower arc is the ω_{sp}

specification limit of 0.87 while the upper arc is restricted by the maximum allowable CAP value. Using the CAP limit of 3.6 and the previously calculated n_z/α , yields an ω_{sp} maximum of 4.1. The diagonal line shows the minimum damping ratio boundary while the maximum damping ratio boundary was omitted since the area of interest lies only above the real axis.

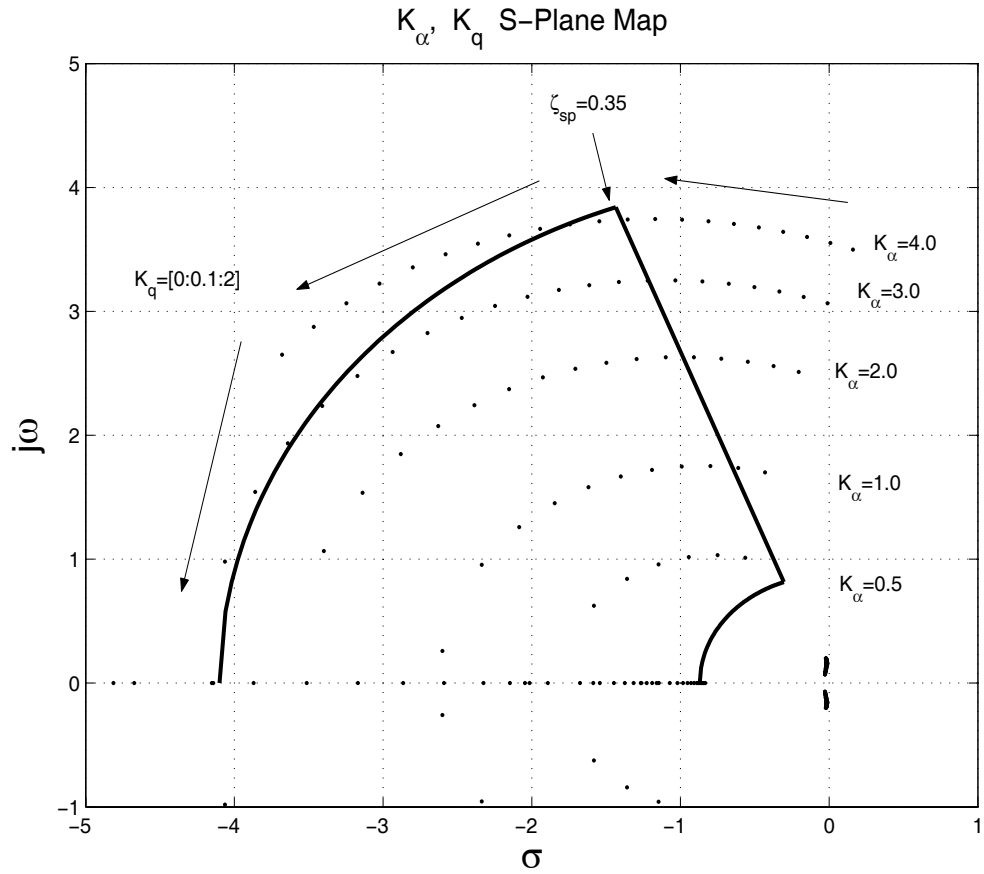

Figure 1. S-Plane Graph of CAP Specification Limits [Ref. 7]

THIS PAGE INTENTIONALLY LEFT BLANK

III. FLIGHT SIMULATION

A. SIMULATOR HARDWARE

The USNTPS flight simulator is a generic cockpit design with primary flight controls systems consisting of a stick and rudder and a dual control throttle quadrant. Flaps, landing gear, and speed brakes are also fully controllable from the cockpit during simulation. Three computer monitors give forward and partial side view representations of the out-the-window-view (OTWV) environment from the cockpit of the simulated aircraft. The center monitor is also capable of overlaying a heads-up-display (HUD) over the OTWV display. An additional monitor provides the heads-down-display (HDD) consisting of standard flight instruments commonly found in military aircraft (attitude reference, airspeed, altimeter, g-meter, etc.) The monitors are controlled by Silicon Graphics Incorporated (SGI) workstations that provide a 30 Hz refresh rate for the visual cueing.[Ref. 8] Figures 2-4 depict the flight simulator cockpit, OTWV and HDD.



Figure 2. Profile of Flight Simulator



Figure 3. Cockpit View of Simulator



Figure 4. OTWV and HDD View of Simulator

Mechanical characteristics of the flight controls are set by an electric control loader and are adjustable to simulate the control systems of a variety of aircraft. The simulator was set up to emulate the appropriate control feel system of the AFCD aircraft. Specifically, breakout, friction and force per displacement gradients were programmed into the simulator for use in data collection.

B. SIMULATOR SOFTWARE

The aerodynamic model is a USNTPS designed, generic model that can be configured to accommodate a variety of aircraft and flight envelopes. The programs are coded primarily in FORTRAN, with some sections that have been modified using C and C++ languages. The software incorporates a graphical user interface (GUI) that allows the user to modify stability and control derivatives to change the flying qualities of the simulated aircraft. The gain values pertinent to the AFCD exercise are also accessible through the GUI.

The software uses the processing power of the SGI workstations to provide update rates as fast as 100Hz. Data collection occurs at a constant 20Hz rate. The user has control over initiating and terminating data collection via a switch found on the control stick. Data collection consists of over 40 parameters including time, pitch rate (q), α , stick and elevator displacement, and airspeed. The simulator software has a native data reduction tool that can generate basic time and frequency domain plots for immediate analysis. For more detailed analysis, the data can be downloaded and converted into a file format that is recognized by MATLAB. This allows feeding the captured stick inputs through a Simulink model to generate an output file for comparison to the simulator results. [Ref. 8]

The simulator captures and records data output in terms of the total value instead of recording deviations from the initial condition. All simulator outputs were shifted to reflect changes from the initial conditions. Since Simulink records deviations from the trim condition, shifting the simulator data allows a direct comparison of the two outputs.

THIS PAGE INTENTIONALLY LEFT BLANK

IV. LEARJET DESCRIPTION

A. GENERAL

The Learjet is a twin-engine low wing passenger transport plane. Pictures of the aircraft exterior and instrument panel are shown in Figures 5 and 6. The basic aircraft has been extensively modified to serve as a VSS platform. Most of the passenger seating has been removed to accommodate additional equipment. The VSS input panels and controllers have been placed in the cockpit for ease of manipulation during flight evolutions.



Figure 5. Learjet



Figure 6. Left and Right Instrument Panels

B. COCKPIT

The cockpit layout features side-by-side seating for two pilots. The safety pilot sits in the left seat and operates the standard Learjet yoke and rudder controls. The student or evaluator sits in the right seat, shown in Figure 7, where the VSS controllers (control stick and modified rudder pedals) have been installed. The VSS flight controls are operated as a fly-by wire (FBW) system. This allows the use of a variable feel system that is similar to, but more advanced than the control loader found in the ground based flight simulator. The feel system can be used to modify the mechanical characteristics of the stick and rudder to emulate those found in almost any fixed wing aircraft.



Figure 7. VSS Controller Cockpit View

C. VARIABLE STABILITY SYSTEM

The VSS augments the evaluation pilot's stick and rudder control inputs to create flight control surface deflections that change the aircraft response to simulate the model programmed into the VSS computer. Electro hydraulic position servos attached to the control surfaces operate independent of, but in parallel with, the normal Learjet flight control system. The VSS servo inputs are not fed back to the controls, thus maintaining the appearance of a true FBW system. Additionally, the feedback gains can be modified to alter the aircraft response characteristics. Figure 8 shows the basic block diagram of the VSS. [Ref. 5]

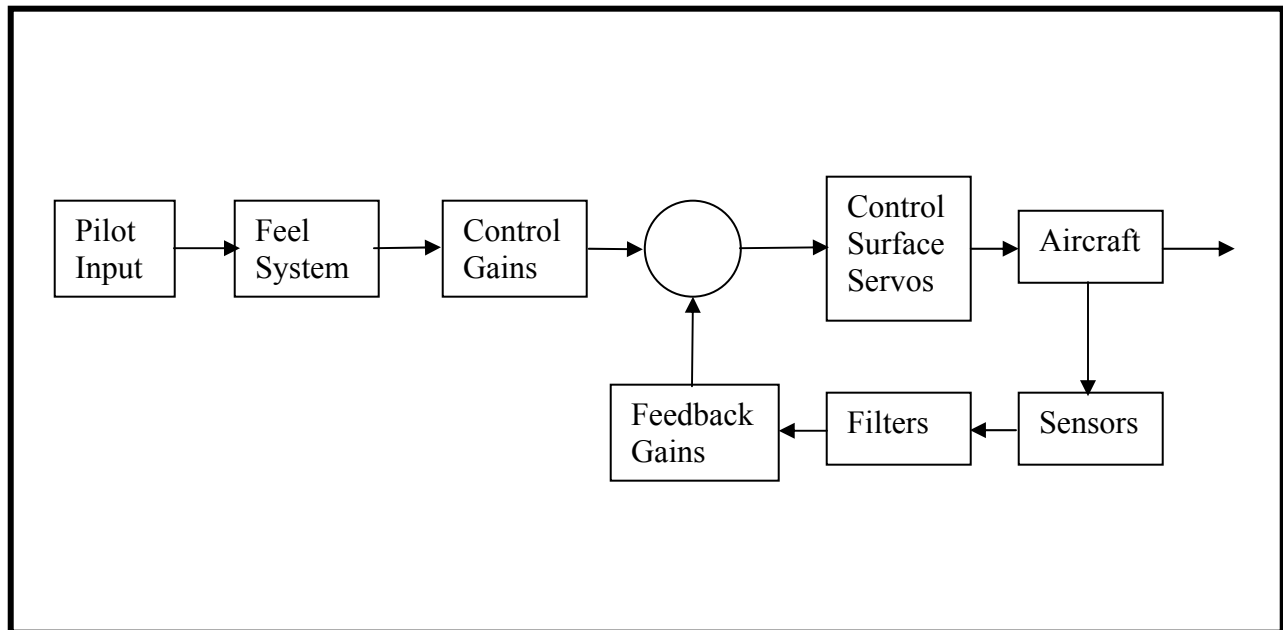

Figure 8. Variable Stability System Block Diagram

D. DATA RECORDING

An onboard computer controls data collection using a sample rate of 100Hz. The safety pilot can control the start and terminate points for data collection. This allows the quick recording of several small files instead of continuously recording the entire flight. Files are downloaded from the aircraft to a desktop computer and, through the use of a data converter, the information is saved as a MATLAB workspace. [Ref. 9]

V. SIMULINK MODELING

A. SIMULINK DISCUSSION

Simulink is a MATLAB-based software tool used for modeling and simulation of systems. The program uses a GUI to allow the user to construct block diagrams of a given system graphically instead of coding the system using a programming language. Simulink was chosen as the primary tool to validate the fidelity of the USNTPS simulator model of the VSS. This was done for several reasons.

The simulator is limited in that any changes other than alteration of the stability and control derivatives or initial conditions is not possible without an in-depth knowledge of FORTRAN and C programming languages. This makes filter and actuator modeling impractical when working with the simulator. Additionally, time domain comparison of simulator and aircraft data is impossible since neither platform is able to accept input files generated by the other system. This prevents using one set of inputs to create two time domain results for both simulator and aircraft. Lastly, the FORTRAN model is obsolete—even the integrated simulator data tool converts the raw data and uses MATLAB to analyze and plot the captured information.

For these reasons, Simulink was used to create a model that would be modern enough to work with present day applications and also be able to determine the validity of the current simulator aircraft model.

B. SIMULINK MODEL INITIAL DEVELOPMENT

During the AFCD exercise, students have access to a Simulink version of the aircraft model for experimentation [Ref. 7]. This model is shown in Figure 9 and is the basis for the model that was developed to examine the fidelity of the simulator. The block diagram is supported by two MATLAB m-files that define the gain values and develop the state space matrices of the aircraft model before the Simulink simulation can be run.

Like the simulator, the Simulink model had not been compared against the aircraft and was in need of validation. Since the flight simulator and the Learjet data couldn't be adequately compared side by side, the Simulink model was necessary to act as a bridge for data comparison. Without any flight data available during early stages of development, the chosen procedure was to modify the Simulink model to provide an accurate representation of the simulator. This would allow the Simulink model to act as a surrogate and use it to directly compare a model against actual flight data. The first step of this process was to eliminate any unnecessary components to remove possible sources of error. As a result, the input side of the model was changed.

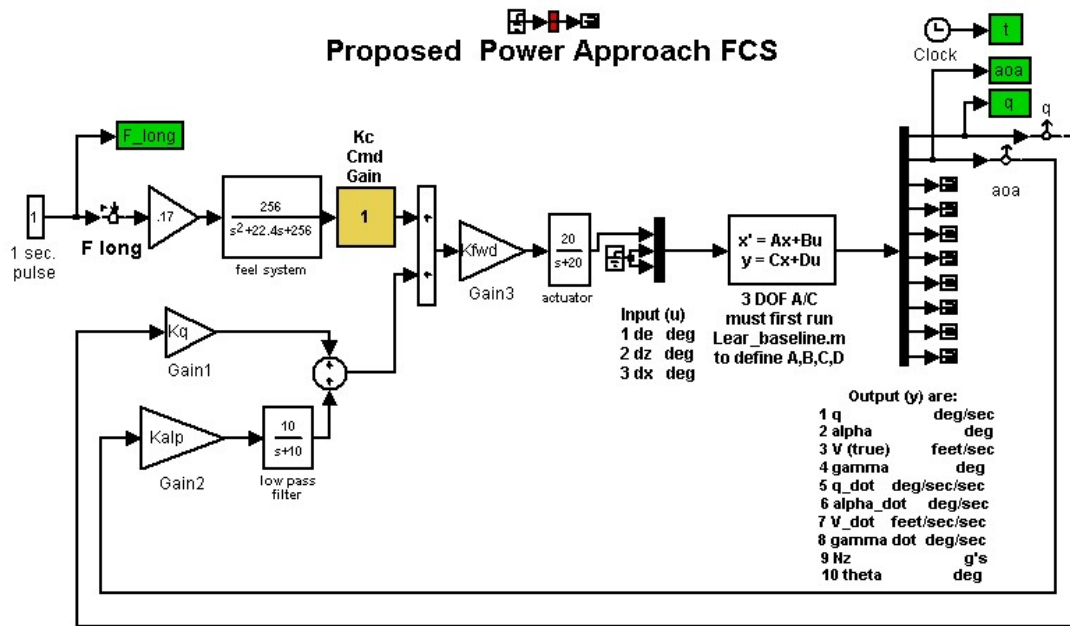

Figure 9. AFCD Simulink Model.

The given model requires stick force (F_s) input to develop elevator deflection commands that are fed through a state space airframe model to generate the output data as shown. Since stick deflection (δ_s) was readily available as an input source from either the simulator or the Learjet, it was chosen as the new input. Utilizing δ_s allowed the removal of the feel system transfer function block.

The command gain for the Simulink model was checked for validity by executing a longitudinal control sweep in the simulator. The control sweep was performed by

zeroing the feedback gains and recording data during a pitch doublet with full fore and aft control stick deflection. Figure 10 shows a plot of the elevator deflection (δ_e) versus δ_s gradient. The sign convention used presents aft stick and downward elevator displacements as positive.

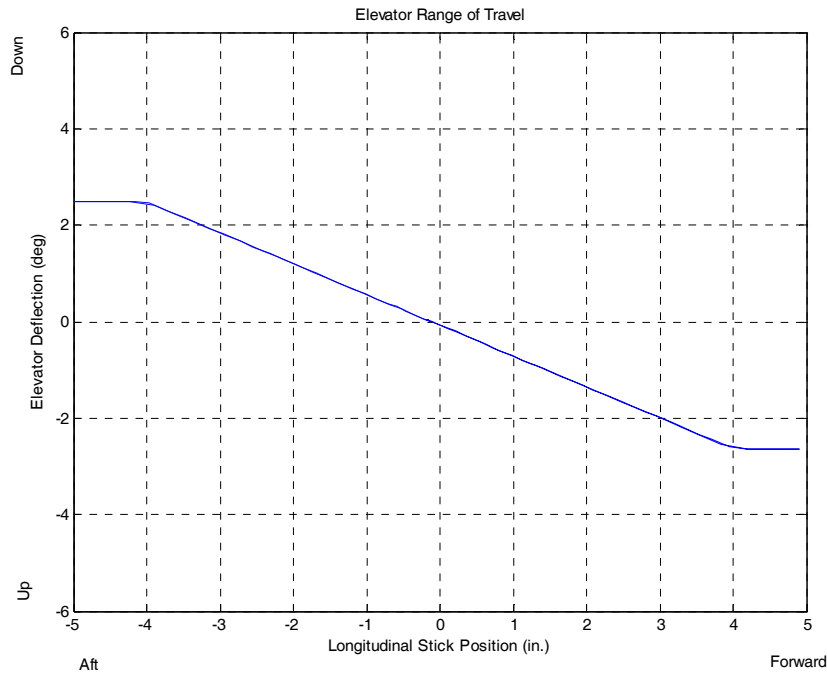

Figure 10. Elevator Deflection vs. Stick Position Gradient

The results show that full stick deflection yielded only a $\pm 2.5^\circ$ elevator travel. This result is not representative of an actual aircraft and was investigated for the source of error. Elevator control power was in line with values associated with fighter aircraft and qualitative evaluation of the simulator flying qualities showed the command gains to be set higher than normal. The discrepancy was determined to be the result of an actuator gain that is built in to the FORTRAN or C code and not modifiable by the user through the GUI. As a result, the elevator travel was mismatched to the actual flying qualities noted in the simulator. Since changing the simulator code was beyond the scope of this investigation, the Simulink model was modified to emulate the erroneous simulator data to provide empirical data that was at

least qualitatively correct. As a result, a command gain of 0.53 was incorporated into the Simulink model based on the average control gradient shown in Figure 11. Spikes in the figure are due to reversal of stick travel after reaching the control stop.

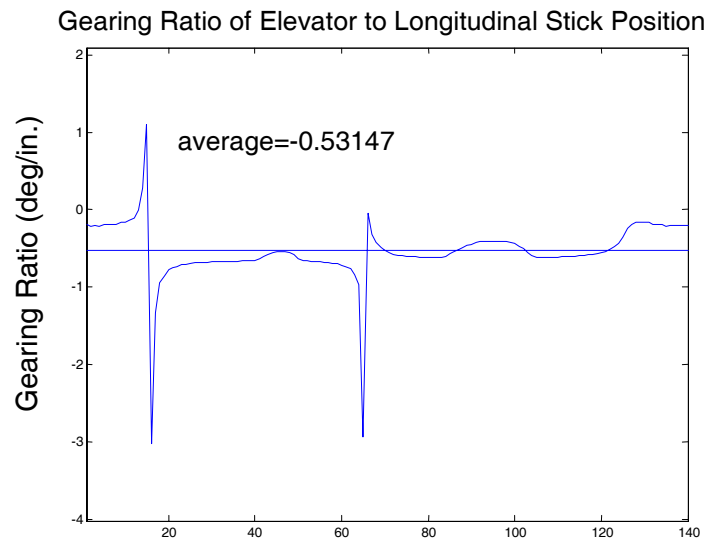

Figure 11. Simulink Command Gain Determination

VI. OPEN LOOP CHARACTERISTICS

A. BASELINE RESPONSE

A reference comparison was needed to examine how well or poorly the two models were in agreement. To that end, a baseline study of the model outputs was performed based on a steady-stick, zero input trace.

1. Simulator Data

The open loop response of a system is the output generated by an input with no feedback control present. The open loop response of the simulator was evaluated by eliminating the feedback paths. Setting K_q and K_r to zero removed the feedback loops from the model and forced the simulator to represent the baseline aircraft that was statically unstable in the longitudinal axis. The stability and control derivatives were not modified from the values that are currently used when teaching the AFCD exercise. Table 2 shows the pertinent test conditions [Ref. 10].

Parameter	Value	Units
W	11500	lbs
V	125	KTAS
h	800	ft
$C_{m\dot{\eta}}$	0.257	---
C_{m_q}	1.0	---
$C_{m\dot{\eta}e}$	-0.7218	---
C_{m_o}	0	---

Table 2. Initial Conditions and Stability Derivatives for Open Loop Test

where

C_{m_α} \square angle of attack stability coefficient

C_{m_q} \square pitch damping coefficient

$C_{m_{\delta_e}}$ \square elevator control power coefficient

C_{m_0} \square moment coefficient at zero angle of attack

Data collection was initiated with the aircraft trimmed for level flight at 125 KIAS in the landing configuration with flaps at the approach setting. Due to slight inaccuracies in the trim subroutine, the simulator was not in a true equilibrium condition. The unbalanced condition and the model instability rapidly caused the aircraft to diverge in the pitch axis. This data was collected as a baseline reference for the simulator model. The only modification made was to shift the output parameters to remove the steady state values.

2. Simulink Data

The Simulink model was also setup for the open loop response by setting the feedback gains to zero. Supporting MATLAB code was modified to set the stability and control derivatives and initial conditions equal to the values that were used in the simulator. The forward loop gain block (K_{fwd}) was assigned a value of one since there was no corresponding component in the simulator reachable through the GUI. Once all of the parameters were established, the recorded longitudinal stick inputs from the simulator were then input to the Simulink model to generate outputs for comparison. The updated Simulink model is shown in Figure 12.

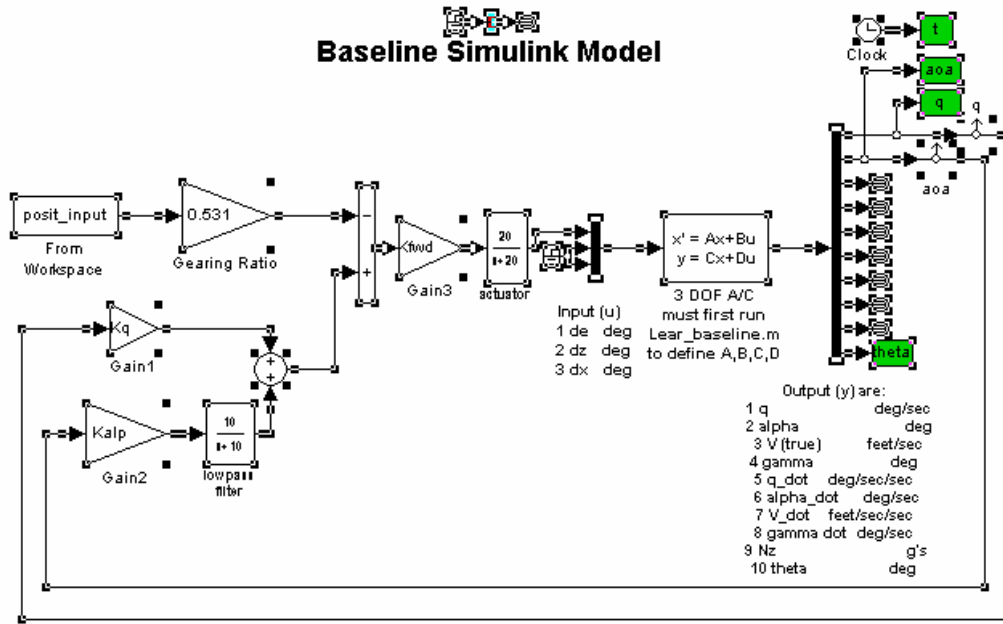

Figure 12. Revised Open Loop Model

The data was then examined and truncated after the pitch divergence caused airspeed to deviate more than 5 kts from the initial value. Data beyond this point was considered unsuitable for evaluation due to possible errors. The Simulink model was linear and calculated derivatives only once based on initial conditions instead of the nonlinear model used in the simulator that constantly updated the coefficients during runtime. Since many of the derivatives used velocity squared in their calculation, a 5 kt boundary around the Learjet approach speeds limited this error to a maximum of approximately 8 percent.

3. Data Comparison

A time domain plot of α versus time was generated to compare the outputs from the simulator and Simulink models. Initial examination showed a similar trend between the two plots, but the Simulink model response appeared to be at a much lower gain. Increasing the K_{fwd} by a factor of 10 brought the time domain response of the Simulink model into close agreement with the simulator results. A plot of this is shown in Figure 13.

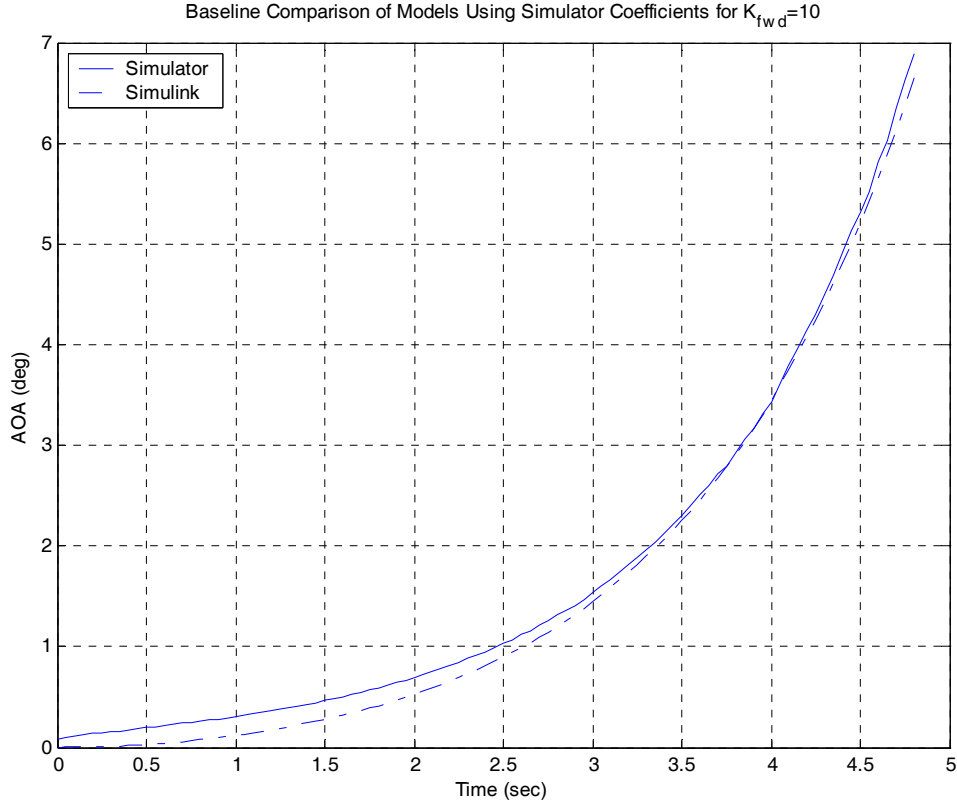

Figure 13. Open Loop α Response Comparison

To verify the similarity of response independent of gain, a plot of the semi-log of $\Delta\alpha$ versus time was constructed with constant time steps ($\Delta t = \text{constant}$). A semi-log plot was constructed such that:

$$slope = \frac{\ln(\Delta\alpha)}{\Delta t} \quad (6)$$

Assuming a 1st order solution based on the nature of the time domain plot, the substitution $\alpha = e^{\lambda t}$, is used to show:

$$slope \cdot \Delta t = \ln(e^{\lambda t_2} - e^{\lambda t_1}) \quad (7)$$

$$= \ln[e^{\lambda(t_2 - t_1)}] \quad (8)$$

$$= \lambda(t_2 - t_1) \quad (9)$$

$$slope \cdot \Delta t = \lambda \Delta t \quad (10)$$

Therefore, the slope must be equal to λ , the real root of the equation of the line [Ref. 11]. Figure 14 shows plots of both models with equal slopes. Since the slopes are equal, the real roots for each system are in good agreement. This validates the Simulink model against the simulator for the unstable open loop case.

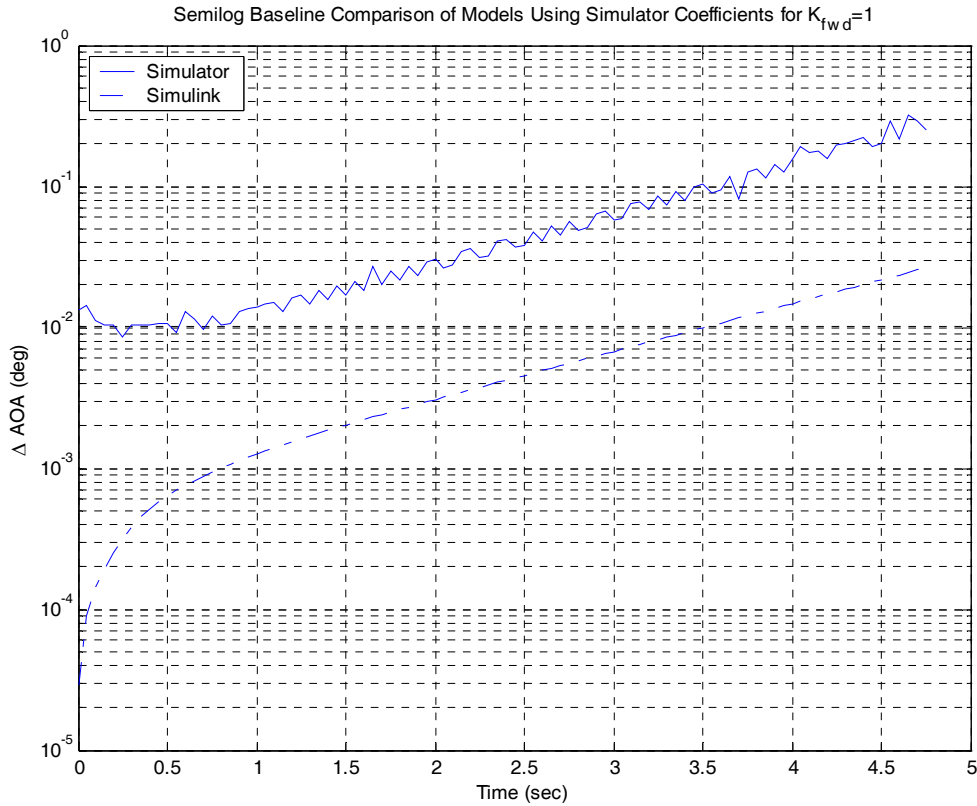

Figure 14. Semi-log Plot for Slope and Real Root Comparison

Again, increasing the K_{fwd} gain by a factor of 10 shifts the Simulink plot up and results in an overlay of the simulator plot. A qualitative assessment of the simulator command gain was attempted, but the high degree of instability in the open loop model prevented determination of a high confidence result.

B. IMPULSE RESPONSE

With the baseline response completed, the impulse response was chosen as the next test to provide a more defined, user-driven response.

1. Simulator Data

Due to the somewhat unpredictable level flight trim settings generated by the simulator, another series of tests was needed to verify the open loop response. The extremely small trim variability was subject to noise, numerical round-off errors and other small factors that affected the baseline results. An impulse was chosen to provide a definite input that would be less sensitive to those errors. An aft stick rap was executed to create a small, short duration aft stick deflection. The magnitude of the stick deflection peaked at approximately 0.2 inches.

2. Simulink Data

The impulse data was fed through the Simulink model to generate the output file. The magnitude of the input was kept small to capture a suitable number of data points before the airspeed deviated below the 5 kt boundary. Even small impulses on this unstable open loop model caused rapid pitch up. After several practice runs and careful implementation of the stick rap, the desired input level was achieved. This input was small enough to yield a little over three seconds of usable data, but large enough to render previously discussed sources of error inconsequential.

3. Data Comparison

The same approach used in the baseline analysis was taken to examine the data from the impulse response. The time domain plots had similar shape but again showed an apparent K_{fwd} gain mismatch. This time the gain required for an overlay of the time domain was 33. The actual gain should have been somewhat lower to account for the known error caused by the airspeed reduction as a result of the pitch up from the impulse. With that in mind, a gain of approximately 25-30 is more appropriate. The required gain

for this trial was 3 times the value observed during the baseline experiment. Since this trial used a deliberate user created input, command gain was more of a factor and there was higher confidence in the larger value. Figure 15 shows the time domain comparison using a mid-value gain of 27.

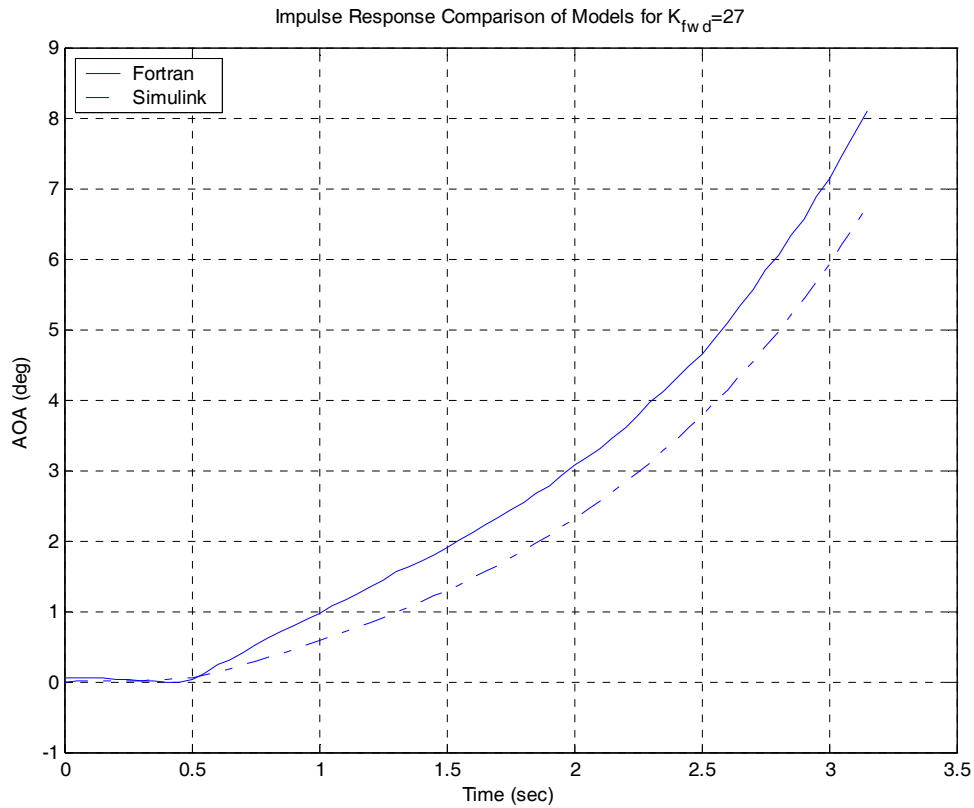

Figure 15. Open Loop α Response to an Aft Stick Impulse

Assuming other errors to be small and the airspeed deviation to be the driving difference between models, a $K_{fwd}=27$ gain shows a likely error divergence that reaches approximately 8 percent at the termination of the trial. The error progression is shown in Figure 16.

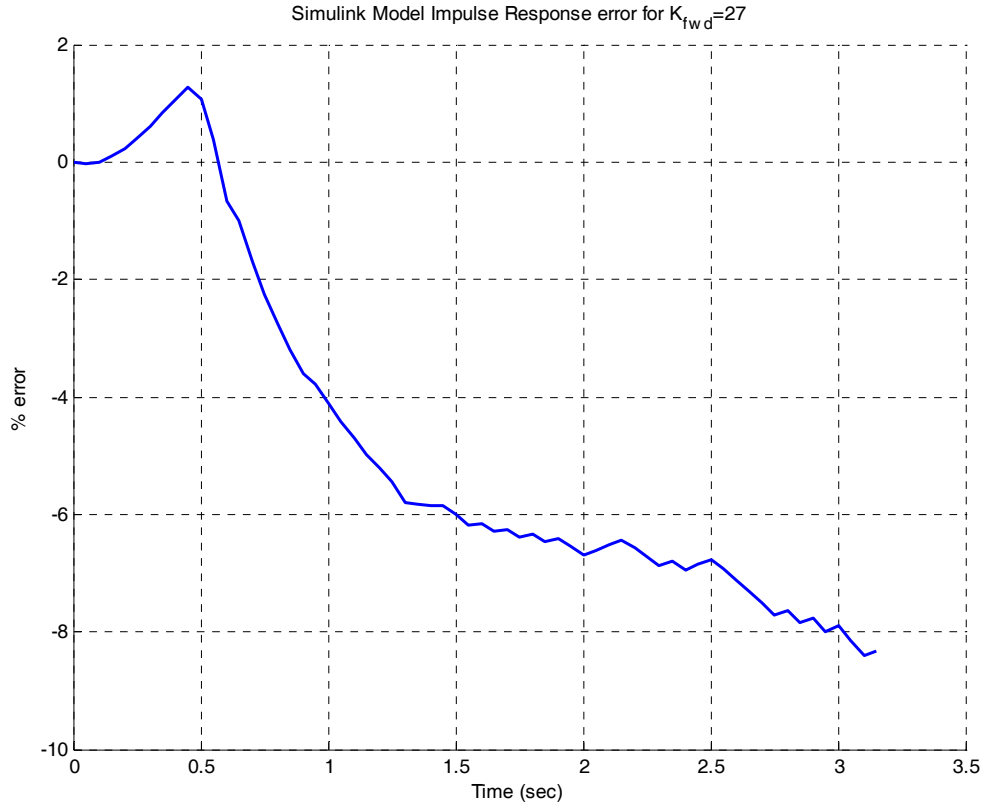

Figure 16. Simulink Model α Error for an Aft Stick Impulse

A plot of the semi-log of $\Delta\alpha$ versus time was constructed for the impulse response to verify that the shape of the response was independent of gain. Similar to the baseline trial, the overall shape and slope of the plot were unaffected by changes in gain. This result again showed that the models had similar real roots and, for the limited open loop unstable case, the Simulink model was a fair representation of the simulator. Figure 17 shows the semi-log plots of both models.

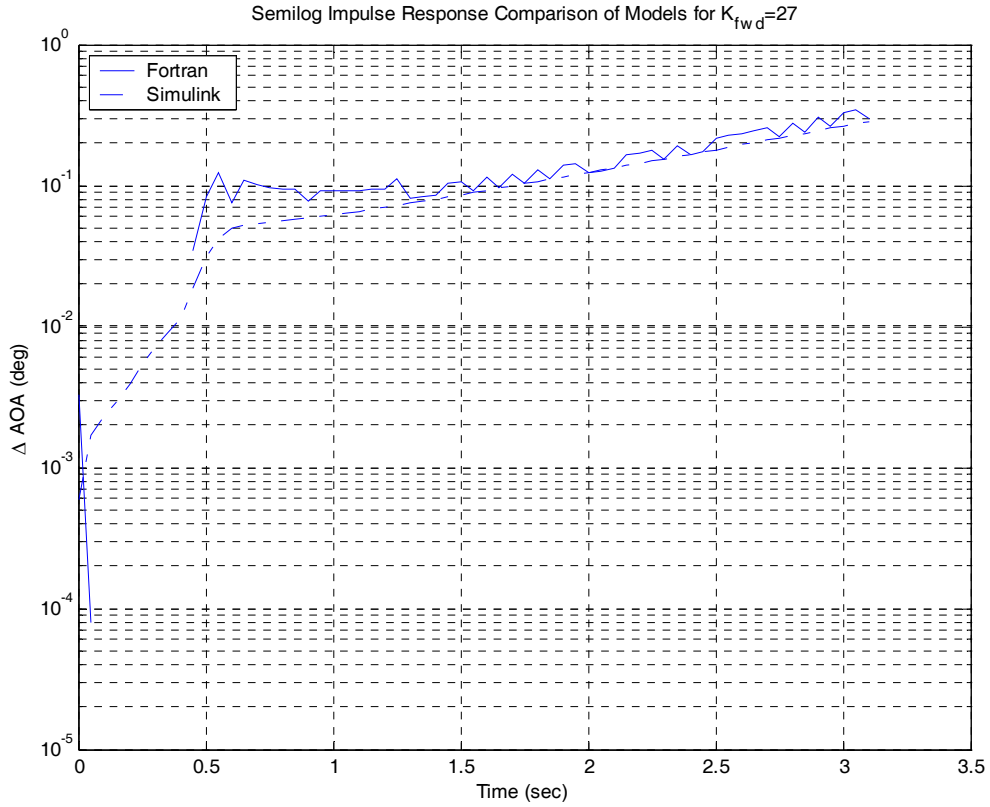

Figure 17. Semi-log Plot for Slope and Real Root Comparison

C. ADDITIONAL ANALYSIS

The baseline and impulse response trials were also completed using the given coefficients from the initial Simulink model [Ref. 7]. Table 3 shows these values compared with the preset simulator values used in the previous trials.

	Simulink	Simulator
$C_{m\dot{q}}$	0.26	0.257
C_{m_q}	-11.49	1
$C_{m\dot{q}e}$	-0.9624	-0.7218
C_{m_o}	-0.004	0

Table 3. Longitudinal Stability Derivative Comparison

This analysis was performed for completeness and to examine the difference in response while using the given Simulink data. Overall, the shape of the plots was similar for each case. Gain matching yielded differences in some cases, but no large discrepancies were noted. Despite even the large change in C_{m_q} , the individual comparisons were roughly the same.

Since the overall goal of these trials was to develop a Simulink model to bridge the gap between simulator and aircraft, the results from use of the simulator coefficients were examined for validation purposes. The results from the trials using Simulink coefficients were used as the first stage of creating a suitable model for use with aircraft data. The Simulink coefficients were used in all subsequent tests because the block diagram could be modified at the actuator and filter levels, whereas the simulator lacked this flexibility.

D. LEARJET DATA

When the Learjet was available for test flights, an attempt was made to collect open loop impulse response data for comparison with the simulator and Simulink models. Unfortunately, the unstable Learjet model was too divergent to establish a valid initial condition while flying and attempts to generate an impulse response resulted in engagement of the internal safety overrides. The safety system disengaged the FBW controls at the evaluator station and the aircraft defaulted to a standard Learjet as the

safety pilot took control. As a result, no usable data was collected for evaluation of open loop characteristics against the simulator or Simulink models.

THIS PAGE INTENTIONALLY LEFT BLANK

VII. CLOSED LOOP TIME DOMAIN MODEL COMPARISON

When the Learjet became available for flight, the focus shifted from open loop to closed loop comparison. The open loop study showed a rough confirmation that the basic simulator and Simulink models were in agreement, but the AFCD exercise dealt with stabilizing the basic aircraft using q and α feedback. Therefore a closed loop study was initiated to improve the fidelity of the Simulink model. With recorded flight data now accessible to provide valid reference parameters, evaluation and adjustment of the block diagram was possible.

A. FLIGHT TEST CONDITIONS AND TECHNIQUES

Several flights were completed by different student test pilots in order to capture project data. The goal was to capture data at low altitude, low speed, and in the approach configuration to simulate conditions encountered during an actual approach to landing. A broad range of feedback and command gains were used to provide validation of the model throughout a large range of acceptable CAP specification limits. Due to airspace constraints, most data was collected at a pressure altitude of 5,500ft. Some flights deviated from this profile due to weather or to avoid other aircraft that were already using that altitude for priority testing. The desired approach airspeed was 125 KIAS, but due to relatively high gross weight of the aircraft during data collection, most testing was initiated at 130-135 KIAS. These altitude and airspeed deviations were accounted for in the setup of the MATLAB code that fed parameters into the Simulink Block Diagram and were not a significant source of error.

The techniques used for data collection were longitudinal stick doublets and frequency sweeps. All tests were initiated from a stable trimmed condition. The doublets were performed by smoothly moving the control stick forward of the center position, then the same distance aft of the center, and positively returning the stick to the starting position. Frequency sweeps were performed as a series of doublets beginning at a slow rate of stick travel and gradually increasing the speed of stick oscillation until the Learjet safety cutoffs engaged [Ref. 12].

B. LEARJET RESPONSE MODELING

The Learjet VSS employed a method of feedback response modeling to alter the apparent flying qualities of the aircraft. This process was achieved in a series of nested feedback loops [Ref. 13]. The baseline Learjet had feedback loops that simulated the statically unstable fighter. The fighter model then employed another set of feedback loops to stabilize the AFCD model according to the student's gain parameters. This setup is diagrammed in Figure 18.

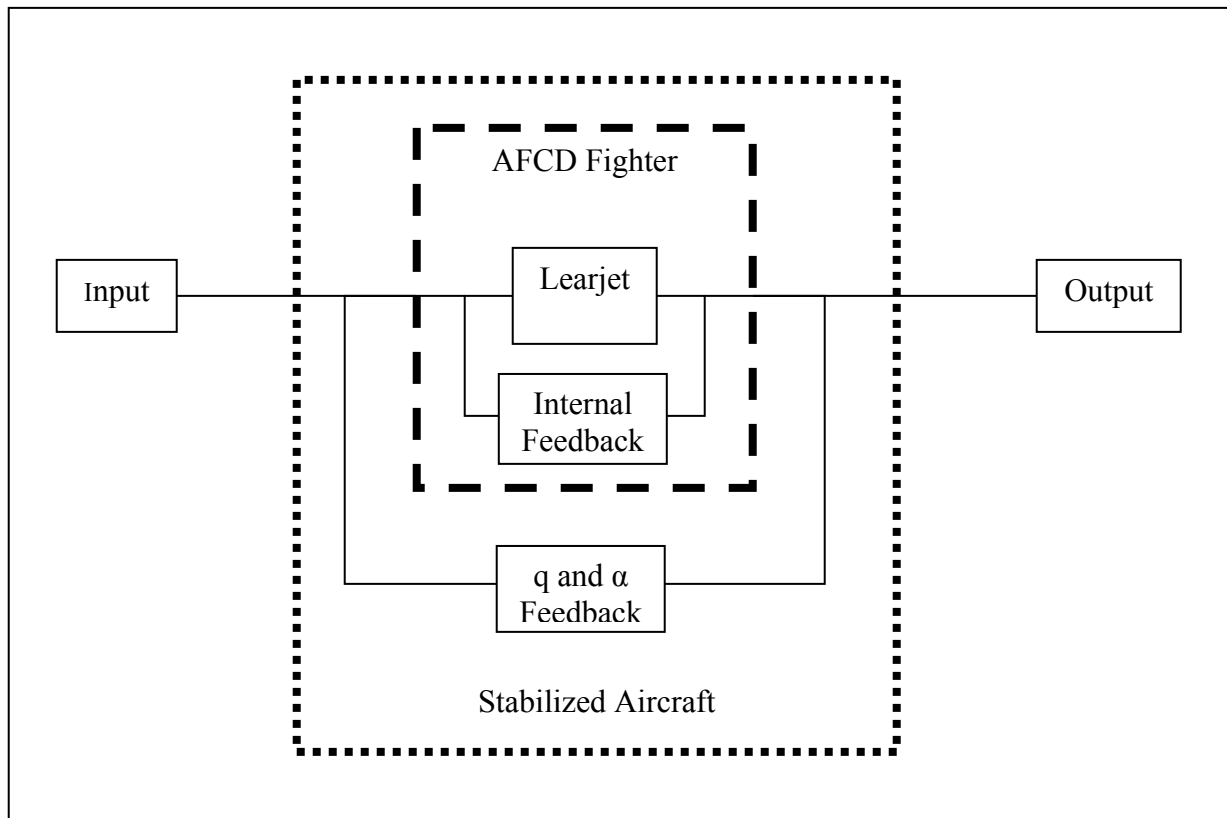

Figure 18. Learjet Response Modeling Block Diagram

C. BLOCK DIAGRAM MODIFICATION

Research into the background of the block diagram provided for student use raised some questions about certain components. As part of the USNTPS course of instruction, the Learjet safety pilots gave a series of lectures on topics surrounding flight

control design. In their presentations [Ref. 6], the Learjet system used a second order actuator, omitted the α -feedback filter, and removed the forward loop gain in favor of a command gain. The Simulink model was altered to reflect these changes, based on the assumption that the Learjet lecture information was more correct and more up-to-date than the AFCD model that was used for the initial open loop study. Figure 19 shows the model after the changes.

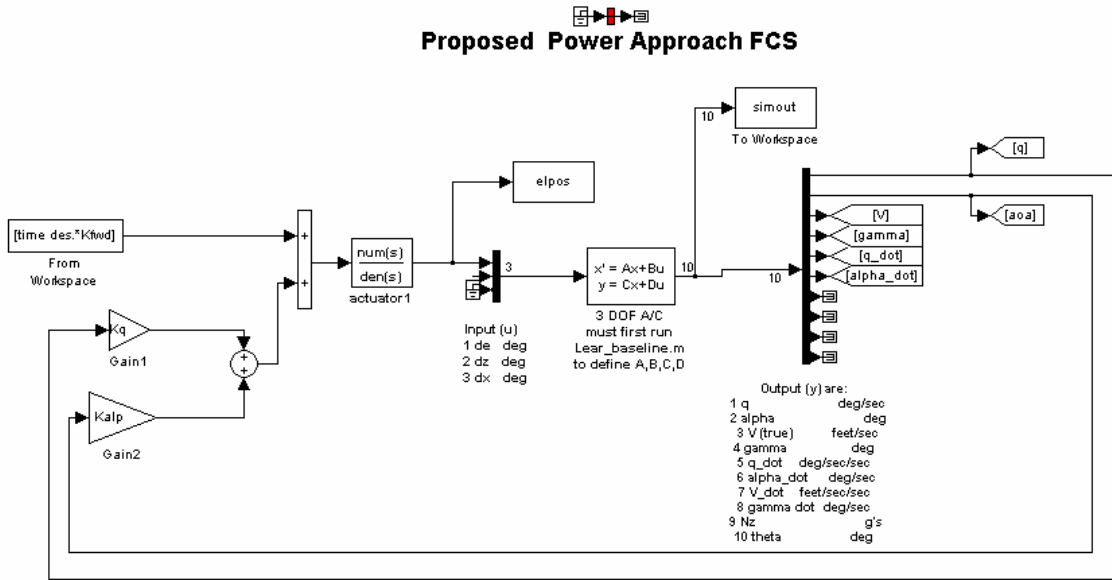

Figure 19. Updated Closed Loop Simulink Model

D. ANGLE OF ATTACK RESULTS

The Learjet longitudinal stick inputs were fed to the Simulink model that generated a time domain output file. The AOA trace was plotted against the Learjet-recorded AOA for evaluation of the model. Figure 20 shows the initial comparison.

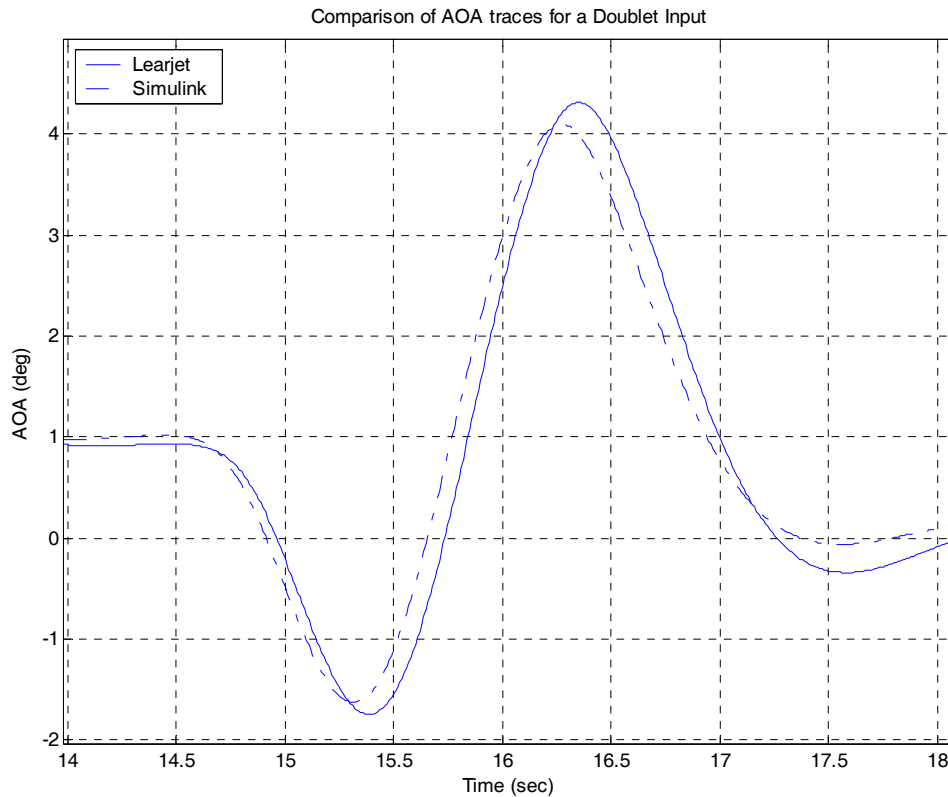

Figure 20. AOA Traces of Simulink and the Learjet

The trace shapes were in good agreement, but there was an apparent time lag that was fairly consistent between the two outputs. Initially, it was thought that the delay was due to a modeling error in that the actuator was incorrect or a filter was missing. However, the Learjet output trace lagged the Simulink data by approximately 120 milliseconds (ms). This delay was too large to be the result of a missing component in the context of a flight control system. To create such a delay, a 6 radian per second actuator (roughly 1 Hz) would be needed. This possibility was immediately discounted because flight control inputs are commonly made at frequencies of 2-3 Hz and 10 Hz inputs are not uncommon. No plausible solution was found for the delay until the VSS engineers were contacted. They verified that the error was a known problem and stated that it was due to a delay in the Learjet data recording system [Ref. 14]. With that knowledge, MATLAB was used to shift the Simulink output data 120 ms forward in time to match the Learjet data and account for the recording lag.

The new plots lined up nicely but a discrepancy between the magnitudes of the traces was now more evident. A basic trial-and-error modification of the elevator control power coefficient was used to yield a better agreement. The old value of -0.96 was decreased to provide the best plot overlays at a range of values between -1.2 to -1.1 . The result of the corrected time lag and $C_{m_{\eta_e}}$ modification is shown in Figure 21.

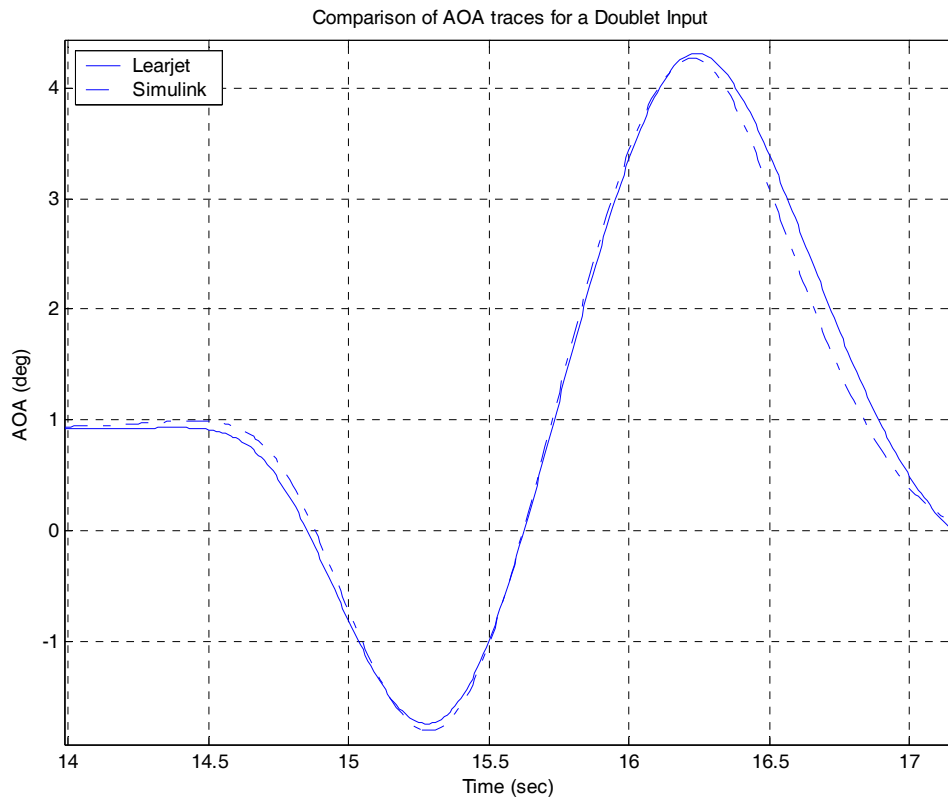

Figure 21. Corrected Learjet and Simulink AOA Traces.

The other moment coefficients were evaluated for their effect on the shape of the time domain Simulink trace. The coefficients $C_{m_{\eta}}$, C_{m_q} , and C_{m_o} , were individually varied approximately $\pm 20\%$ of the baseline AFCD values. After each trial, the AOA trace was examined for convergence toward or divergence from the Learjet data. Within the $\pm 20\%$ range, each of the coefficients was relatively insensitive to change. None of the trials showed a visibly significant difference in the plots.

E. ELEVATOR POSITION RESULTS

To better evaluate the differences between the Simulink and Learjet AOA traces, plots of elevator displacement were created for comparison. The same Learjet longitudinal stick inputs were fed to the Simulink model to generate a time domain output file of elevator position. With AOA traces in good agreement, the elevator displacements were expected to be in similar agreement. However, Figure 22 shows that they are in phase, but the magnitudes are dissimilar.

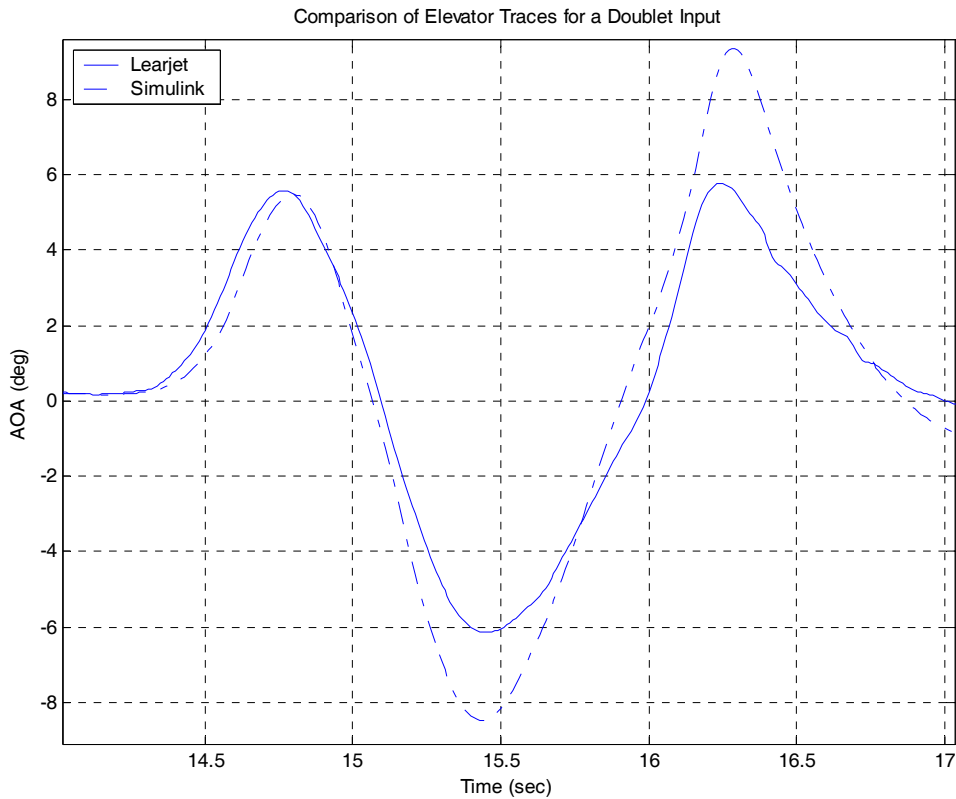

Figure 22. Elevator Displacement Traces of Simulink and the Learjet

Investigation as to the cause of the discrepancy led to a closer inspection of the available Learjet data files. In addition to recording the actual elevator deflection (de), the VSS system also recorded the commanded elevator deflection (dec). An overlay plot of the two showed a difference between them. To examine this difference, flight data

from a control sweep was used to construct a bode plot. The dec data was used as the input and de was used for as the output. The resulting plot is shown in Figure 23.

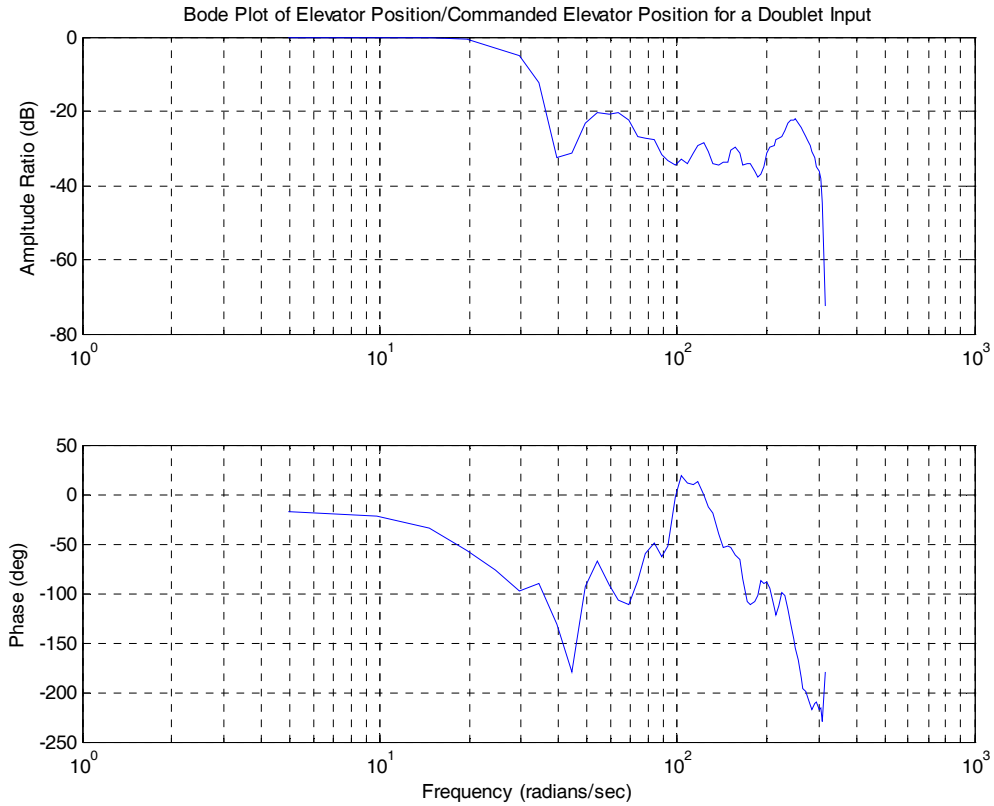

Figure 23. Bode Plot of Elevator Deflection

The upper plot clearly shows an amplitude roll-off at 20 radians per second. This is indicative of a first-order 20-radian actuator. It seemed more than coincidence that the initial AFCD model used such an actuator. The AFCD model correctly employed a first-order 20-radian actuator, but implemented it incorrectly in the block diagram. This new actuator was evidently nested inside the feedback loop that destabilized the baseline Learjet to create the unstable AFCD fighter. As a result, comparisons of elevator deflection between the aircraft and the Simulink model are not useful since the model lacks the state space parameters of the baseline Learjet. Insufficient data was available to examine the internal nested loop that served to destabilize the baseline Learjet and model the AFCD fighter. However, the 20-radian actuator was added to the Simulink model to send more accurate elevator data into the state space parameter block for the baseline

AFCD fighter. This was done to improve the fidelity of the block diagram for comparisons of longitudinal flight parameters such as AOA and pitch.

VIII. EQUATIONS OF MOTION

A. ASSUMPTIONS

Several assumptions were made to simplify the equations of motion for use in this study. They are listed as follows [Ref. 15]:

1. Small pitch and elevator deflections ($\leq 10^\circ$).
2. Rigid airframe with no aeroelastic effects.
3. Axis system origin co-located with the aircraft center of gravity.
4. Aircraft symmetry where $I_{xy} = I_{yz} = 0$.
5. Negligible change in mass distribution during the test runs.

These were valid assumptions based on the scope of the test runs. Control inputs were small resulting in small pitch changes. Small inputs made at the relatively low speeds (>150 kts) resulted in little stress on the airframe. The simulator and Simulink models both assumed $I_{xy} = I_{yz} = 0$, so this assumption was considered valid. The Learjet configuration was consistent during data collection. The duration of testing was short so fuel burn was considered to have negligible effect on mass distribution.

B. DEVELOPMENT OF EQUATIONS

By using the stated assumptions, it was possible to start with the simplified general equations of motion shown here [Ref. 16]:

$$L = \dot{P}I_{xx} + QR(I_{zz} - I_{yy}) - \dot{R}I_{xz} - PQI_{xz} \quad (11)$$

$$M = \dot{Q}I_{yy} + PR(I_{xx} - I_{zz}) + (P^2 - R^2)I_{xz} \quad (12)$$

$$N = \dot{R}I_{zz} + PQ(I_{yy} - I_{xx}) - \dot{P}I_{xz} + QRI_{xz} \quad (13)$$

where

$I \equiv$ Moment of Inertia

$L \equiv$ Roll moment

$M \equiv$ Pitch moment

$N \equiv$ Yaw moment

$P \equiv$ Roll rate

$Q \equiv$ Pitch rate

$R \equiv$ Yaw rate

The simulator used in the student exercise was assumed to be linear. Additionally, the simulator was based on uncoupled motion. This amounts to fixing velocity components P and R at zero while studying longitudinal stability. As a result only the pitching moment equation remained [Ref. 16]:

$$M = \dot{Q} I_{yy} \quad (14)$$

Equation (14) was then expanded as the sum of partial derivatives:

$$\frac{\partial M}{\partial u} \Delta u + \frac{\partial M}{\partial q} \Delta q + \frac{\partial M}{\partial \alpha} \Delta \alpha + \frac{\partial M}{\partial \dot{\alpha}} \Delta \dot{\alpha} + \frac{\partial M}{\partial \delta_e} \Delta \delta_e = \dot{Q} I_{yy} \quad (15)$$

$u \equiv$ Velocity component along the X-axis

$q \equiv$ Pitch rate

Changes in u and $\dot{\alpha}$ were assumed to be small [Ref. 15], thus those two terms were dropped from the equation. The remaining terms are shown here:

$$\frac{\partial M}{\partial q} \Delta q + \frac{\partial M}{\partial \alpha} \Delta \alpha + \frac{\partial M}{\partial \delta_e} \Delta \delta_e = \dot{Q} I_{yy} \quad (16)$$

Dividing both sides by the pitching moment of inertia, I_{yy} , results yields:

$$\dot{q} = M_q \cdot q + M_\alpha \cdot \alpha + M_{\delta_e} \cdot \delta_e \quad (17)$$

where

$\dot{q} \equiv$ q-dot, pitch acceleration

$M_q \equiv$ dimensional pitch damping coefficient

$M_\alpha \equiv$ dimensional pitch stability coefficient

$M_{\delta_e} \equiv$ dimensional elevator control power coefficient

THIS PAGE INTENTIONALLY LEFT BLANK

IX. REGRESSION ANALYSIS

With the Simulink diagram modified to include the proper components and provide fairly accurate time domain comparisons, a more in-depth examination of the AFCD stability coefficients in the state space model was initiated. Since the model had been extensively revised, most remaining discrepancies were assumed to be related to the longitudinal moment coefficients. Since the analytical model was linear, a regression study was performed as a means of parameter identification with the final goal being validation of the moment coefficients.

A. REGRESSION THEORY

Linear regression is a simple method of examining how several components contribute to a final result. In the case of this study, pitch acceleration (\dot{q}) was the parameter of interest. Pitch acceleration was chosen because it is one of the values solved for in the longitudinal equations of motion. The other two values of linear and vertical acceleration were also important, but the VSS and the flight simulator did not provide a means of varying the coefficients in those equations. Therefore, \dot{q} was chosen as the primary parameter for investigation. The equation of interest developed previously is shown again here:

$$\dot{q} = M_q \cdot q + M_\alpha \cdot \alpha + M_{\delta_e} \cdot \delta_e \quad (18)$$

In a strict flight mechanics sense these coefficients are actually stability derivatives, but here in the context of a regression analysis they were treated as coefficients.

B. METHOD

MATLAB was used to perform a regression based on a \dot{q} vector and a matrix of q , α , and δ_e vectors. Before attempting to analyze flight data with this method, a purely analytical Simulink exercise was constructed to validate the regression technique

[Ref. 17]. The Simulink model was used to generate the vectors based on the stick inputs from a control sweep recorded in the Learjet. The regression was then executed in MATLAB to develop the dimensional coefficients. These regression coefficients were then compared to the coefficients calculated for use in the state space matrices in the block diagram. The resulting sets of coefficients were identical to 4 decimal places of accuracy. This was expected since the Simulink model was linear with no noise or disturbances and the regression method was also linear in nature. No data was collected in this process; it was simply used to check the validity of using the regression approach for parameter identification.

Once the method was validated, regression analysis was used to evaluate flight test data. Ten control sweeps were collected from different pilots to provide a broad sample of data. Additionally, the command and feedback gain values were varied for each sweep to examine a large portion of the CAP specification limit envelope.

C. RESULTS

Regressions were performed on all of the flight data files yielding values for the dimensional coefficients and 95% confidence intervals around each data point. The data was averaged for each dimensional coefficient to provide a baseline set of flight coefficients from these mean values. The data set for each dimensional coefficient was then plotted against the corresponding mean value. The 95% confidence interval was plotted around the individual data points for reference as well as a one standard deviation upper and lower bound around the mean. The resulting graphs for M_q , M_α , and M_{δ_e} are shown in Figures 24, 25, and 26 respectively.

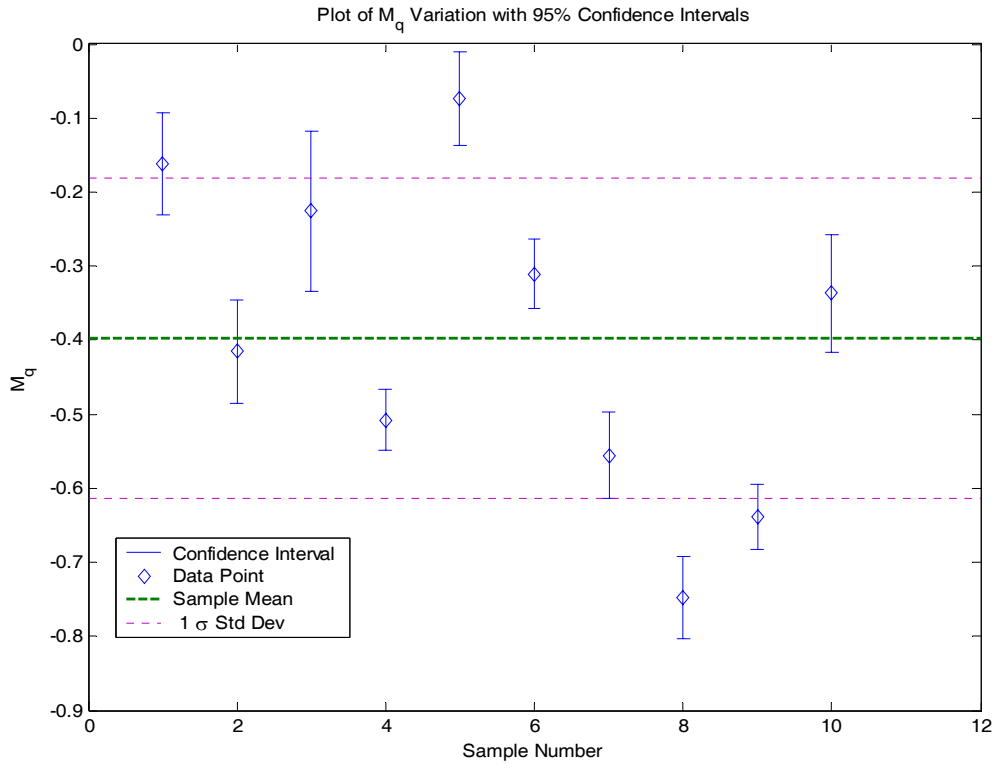

Figure 24. Regression Results for M_q Parameter Identification

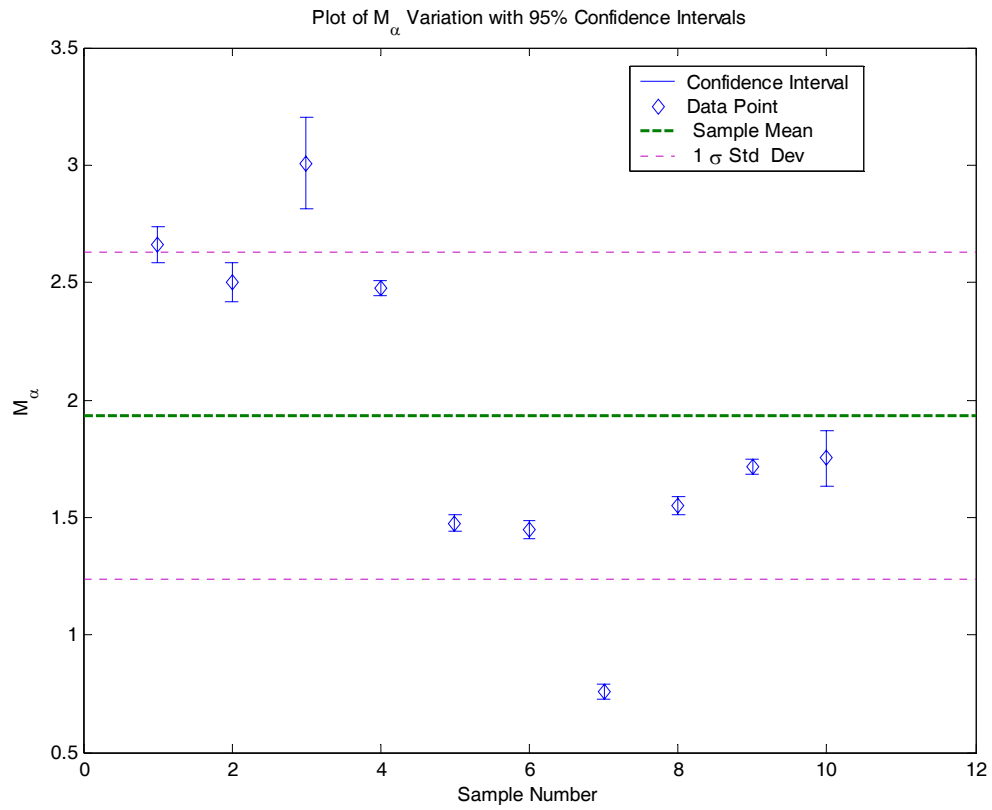

Figure 25. Regression Results for M_α Parameter Identification

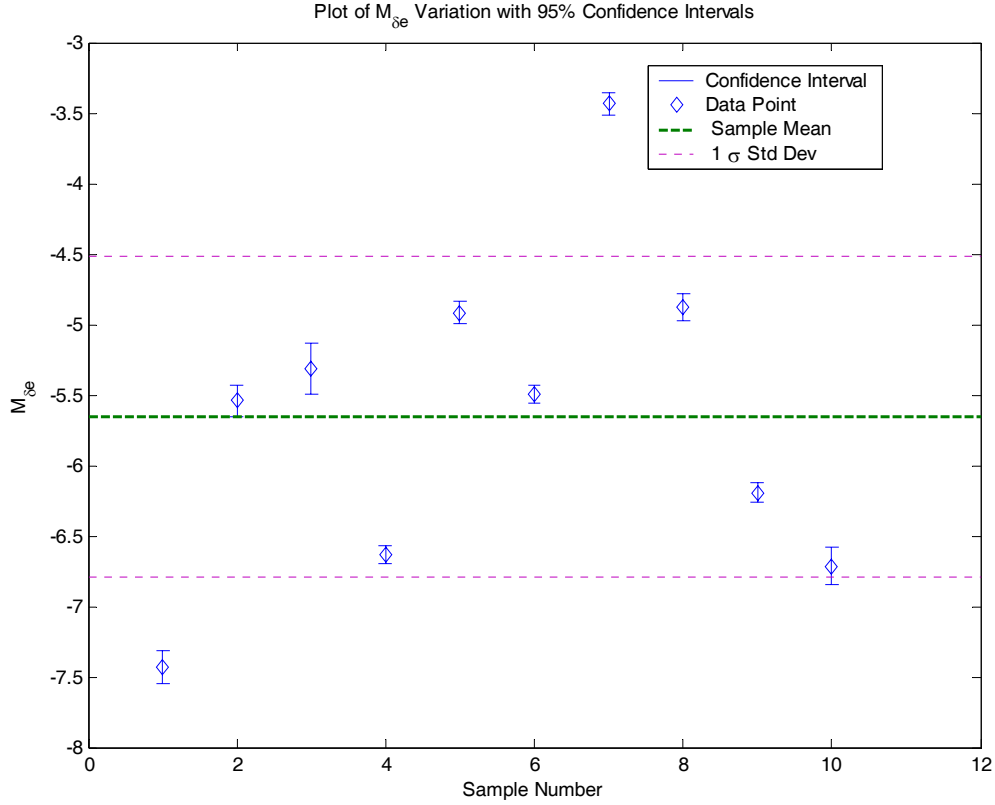

Figure 26. Regression Results for M_{δ_e} Parameter Identification

The simulator and the Simulink models both utilized the coefficients in their non-dimensional form so the first step toward meaningful comparison of the results shown in the plots was to convert the dimensional results.

The pitch damping term was converted to non-dimensional form as follows [Ref. 16]:

$$M_q = \frac{\frac{\partial M}{\partial q}}{I_{yy}} = \frac{c_{m_q} \frac{\bar{c}}{2V} q S \bar{c}}{I_{yy}} \quad (19)$$

where

$\bar{c} \equiv$ mean aerodynamic chord length

The q in the right side of the equation is the dynamic pressure. To prevent confusion with using q as pitch rate, the following substitution for dynamic pressure was made [Ref. 4]:

$$q = \frac{1}{2} \rho V^2 \quad (20)$$

Substituting this into Equation (19) and solving for the non-dimensional pitch damping coefficient yields:

$$c_{m_q} = \frac{2I_{yy} M_q}{\rho V S c^2} \quad (21)$$

Similarly, the angle of attack stability and elevator control power coefficients were solved for and yielded the following equations:

$$c_{m_\alpha} = \frac{2I_{yy} M_\alpha}{\rho V^2 S c} \quad (22)$$

$$c_{m_{\delta_e}} = \frac{2I_{yy} M_{\delta_e}}{\rho V^2 S c} \quad (23)$$

The following values for the Learjet at 5,500ft MSL and 135 KIAS were used to compute the dimensionless coefficients [Ref. 18]:

$$I_{yy} = 22,000 \text{ slug}\cdot\text{ft}^2$$

$$\rho = 0.0020173 \text{ slugs/ft}^3$$

$$V = 247.5 \text{ ft/sec}$$

$$S = 232 \text{ ft}^2$$

$$\bar{c} = 7 \text{ ft}$$

Table 4 shows the results of the calculations and also lists the simulator and Simulink model values for comparison.

	Simulink	Simulator	Flight Data Regression
$C_{m\dot{\eta}}$	0.26	0.257	0.417
$C_{m\dot{q}}$	-11.49	1	-3.10
$C_{m\dot{\eta}e}$	-0.9624	-0.7218	-1.25

Table 4. Dimensionless Coefficient Comparison

D. DISCUSSION

It is readily apparent that the flight data differs from both the Simulink and Simulator model data. Figures 24-26 show favorable confidence level bands but large standard deviations for the M_α and M_{δ_e} data points. The M_q data has larger confidence level bands suggesting a degree of uncertainty in that data.

The large standard deviations in the coefficients resulted in a large range of possible values for the coefficients. In the case of M_q , the range was $\pm 50\%$ of the mean value. This variability was too large to make meaningful comparisons of the flight results and the simulator/Simulink models.

The standard deviation size may be partly due to the fact that different pilots were used to collect the data and were not well versed in the data collection technique. Additional errors are likely due to the real world nonlinearities being modeled by linearized and simplified systems.

X. CONCLUSIONS AND RECOMMENDATIONS

Based on the flight data collected it was not possible to validate the simulator model against the Learjet VSS. Further flight testing is recommended to determine if this comparison could work or if the Simulink model must be changed to a less simplified form.

Further flight data collection is recommended with several collections being taken by the same pilot on the same event. This would remove a possible source of data inconsistency. Additionally, further use of Matlab or other means to conduct spectral analysis of the data may provide insight into the fidelity of the model.

The Simulink model used as a learning aid for the TPS AFCD curriculum was improved and is now a better match to the ground based simulator also used in that exercise. Several blocks in the model were altered, with some removed and some added. Additionally, the gains values were changed to improve the fidelity of the model.

THIS PAGE INTENTIONALLY LEFT BLANK

LIST OF REFERENCES

1. Military Standard, *Flying Qualities of Piloted Vehicles*, MIL-STD-1797A, 30 Jan 1990.
2. Cooper, George E. and Harper, Robert P. Jr., "The Use of Pilot Rating in the Evaluation of Aircraft Handling Qualities," NASA Technical Note D-5153, April 1969.
3. Military Specification, *Flying Qualities of Piloted Airplanes*, MIL-F-8785C, 5 November 1980.
4. Anderson, John D., *Intro to Flight*, McGraw Hill, Boston, Massachusetts, 2000.
5. Buethe, S, *Learjet Flight Syllabus and Background Material for the US Air Force/US Naval Test Pilot School Variable Stability Programs*, 11 January 2002.
6. Easter, John R., *United States Naval Test Pilot School Advanced Flight Control System Learjet Demonstration/Evaluation Flight Briefing Notes*, 6 March 2001.
7. Miller, R. V., *Advanced Flight Controls Notes*, Patuxent River, Winter/Spring 2004.
8. King, J. T., "History of Ground-Based Simulation at USNTPS"
9. Conversations between S. Buethe and the Author, March 2004.
10. Ground Based Simulator Parameters, Spring 2004.
11. *Introduction to Dynamics*, United States Naval Test Pilot School, November 1994.
12. *Fixed Wing Stability and Control Theory and Flight Test Techniques*, United States Naval Test Pilot School Flight Test Manual, January 1997.
13. "Variable Stability Training Program", General Dynamics, parent corporation of Veridian Systems.
14. Conversations between J. Easter, M. Parrag, and the Author, April 2004.
15. Dungan, *Fixed Wing Aircraft Static Stability and Control Class Notes*, Patuxent River, Winter/Spring 2004.
16. *Airplane Dynamics*, United States Naval Test Pilot School, December 1992.
17. Miller, R. V., *Statistics*, United States Naval Test Pilot School, October 1994.
18. Ohmit, E. E. and Knotts, L. H., *United States Naval Test Pilot School Augmented Aircraft Handling Qualities*, General Dynamics, March 2004.

THIS PAGE INTENTIONALLY LEFT BLANK

INITIAL DISTRIBUTION LIST

1. Defense Technical Information Center
Ft. Belvoir, VA
2. Dudley Knox Library
Naval Postgraduate School
Monterey, CA
3. Isaac Kaminer
Naval Postgraduate School
Monterey, CA
4. Mark Rhoades
Naval Postgraduate School
Salinas, CA