



**NAVAL
POSTGRADUATE
SCHOOL**

MONTEREY, CALIFORNIA

THESIS

**DESIGN AND FABRICATION OF A PLANAR
AUTONOMOUS SPACECRAFT SIMULATOR WITH
DOCKING AND FLUID TRANSFER CAPABILITY**

by

Tracy Shay

December 2005

Thesis Advisor:

Marcello Romano

Approved for public release; distribution unlimited

THIS PAGE INTENTIONALLY LEFT BLANK

| REPORT DOCUMENTATION PAGE | | | Form Approved OMB No. 0704-0188 | |
|--------------------------------------------------------------------------------------------------------------------------------------------------------------------------------------------------------------------------------------------------------------------------------------------------------------------------------------------------------------------------------------------------------------------------------------------------------------------------------------------------------------------------------------------------------------------------------------------------------------------------------------------------------------------------------------------------------------------------------------------------------------------------------------------------------------------------------------------------------------------------------------------------------------------------------------------------|----------------------------------------------------------|---------------------------------------------------------|-----------------------------------------------------|--|
| Public reporting burden for this collection of information is estimated to average 1 hour per response, including the time for reviewing instruction, searching existing data sources, gathering and maintaining the data needed, and completing and reviewing the collection of information. Send comments regarding this burden estimate or any other aspect of this collection of information, including suggestions for reducing this burden, to Washington headquarters Services, Directorate for Information Operations and Reports, 1215 Jefferson Davis Highway, Suite 1204, Arlington, VA 22202-4302, and to the Office of Management and Budget, Paperwork Reduction Project (0704-0188) Washington DC 20503. | | | | |
| 1. AGENCY USE ONLY (Leave blank) | | 2. REPORT DATE December 2005 | 3. REPORT TYPE AND DATES COVERED Master's Thesis | |
| 4. TITLE AND SUBTITLE: Design and Fabrication of a Planar Autonomous Spacecraft Simulator with Docking and Fluid Transfer Capability | | | 5. FUNDING NUMBERS | |
| 6. AUTHOR(S) Tracy J. Shay | | | | |
| 7. PERFORMING ORGANIZATION NAME(S) AND ADDRESS(ES) Naval Postgraduate School Monterey, CA 93943-5000 | | | 8. PERFORMING ORGANIZATION REPORT NUMBER | |
| 9. SPONSORING /MONITORING AGENCY NAME(S) AND ADDRESS(ES) N/A | | | 10. SPONSORING/MONITORING AGENCY REPORT NUMBER | |
| 11. SUPPLEMENTARY NOTES The views expressed in this thesis are those of the author and do not reflect the official policy or position of the Department of Defense or the U.S. Government. | | | | |
| 12a. DISTRIBUTION / AVAILABILITY STATEMENT Approved for public release; distribution unlimited | | | 12b. DISTRIBUTION CODE | |
| 13. ABSTRACT (maximum 200 words) The objective of this thesis is to describe the concept development, design, system integration, and operating procedures for the AUDASS II vehicle (Autonomous Docking and Spacecraft Servicing Simulator). The AUDASS II is an improved follow on design of AUDASS I, developed in September of 2002. The purpose of AUDASS II is to simulate a chaser spacecraft autonomously rendezvousing and docking with a target spacecraft for the purpose of conducting fluid transfer. This demonstration involves two vehicles elevated, via air pads, upon a smooth epoxy surface, thus allowing three near frictionless degrees of freedom. The ultimate goal of this thesis is to fabricate a vehicle and requisite documentation that will allow future students to conduct experiments using different control algorithms and/or sensors to conduct autonomous rendezvous and docking maneuvers. | | | | |
| 14. SUBJECT TERMS Autonomous docking, autonomous rendezvous, spacecraft servicing. | | | 15. NUMBER OF PAGES 71 | |
| | | | 16. PRICE CODE | |
| 17. SECURITY CLASSIFICATION OF REPORT Unclassified | 18. SECURITY CLASSIFICATION OF THIS PAGE Unclassified | 19. SECURITY CLASSIFICATION OF ABSTRACT Unclassified | 20. LIMITATION OF ABSTRACT UL | |

THIS PAGE INTENTIONALLY LEFT BLANK

Approved for public release; distribution unlimited

**DESIGN AND FABRICATION OF A PLANAR AUTONOMOUS DOCKING
SIMULATOR WITH DOCKING AND FLUID TRANSFER CAPABILITY**

Tracy J. Shay
Lieutenant Commander, United States Navy
B.A., University of Texas, 1992

Submitted in partial fulfillment of the
requirements for the degree of

MASTER OF SCIENCE IN ASTRONAUTICAL ENGINEERING

from the

**NAVAL POSTGRADUATE SCHOOL
December 2005**

Author: Tracy J. Shay

Approved by: Marcello Romano
Thesis Advisor

Anthony J. Healy
Chairman, Department of Mechanical and Astronautical
Engineering

THIS PAGE INTENTIONALLY LEFT BLANK

ABSTRACT

The objective of this thesis is to describe the concept development, design, system integration, and operating procedures for the AUDASS II vehicle (Autonomous Docking and Spacecraft Servicing Simulator). The AUDASS II is an improved follow on design of AUDASS I, developed in September of 2002. The purpose of AUDASS II is to simulate a chaser spacecraft autonomously rendezvousing and docking with a target spacecraft for the purpose of conducting fluid transfer. This demonstration involves two vehicles elevated, via air pads, upon a smooth epoxy surface, thus allowing three near frictionless degrees of freedom.

The ultimate goal of this thesis is to fabricate a vehicle and requisite documentation that will be used by future students to conduct experiments using different control algorithms and/or sensors to conduct autonomous rendezvous and docking maneuvers.

THIS PAGE INTENTIONALLY LEFT BLANK

TABLE OF CONTENTS

| | | |
|-------------|----------------------------------------------------------------------|-----------|
| I. | INTRODUCTION..... | 1 |
| A. | BACKGROUND | 1 |
| | 1. Autonomous Rendezvous and Docking Research..... | 1 |
| | 2. Similar Vehicles..... | 3 |
| B. | AUTONOMOUS DOCKING SPACECRAFT SERVICING SIMULATOR II..... | 4 |
| | 1. AUDASS II Test Bed Concept | 4 |
| | 2. Vehicle Position Determination | 5 |
| | 3. Vehicle Control..... | 6 |
| | 4. Scope of Thesis | 7 |
| II. | AUDASS II DESIGN | 9 |
| A. | CONCEPT DEVELOPMENT..... | 10 |
| | 1. Modularity | 10 |
| | 2. Docking Mechanism Integration | 11 |
| | 3. Reaction Wheel Upgrade..... | 12 |
| | 4. Performance Enhancing Component Selection..... | 13 |
| | 5. Performance Enhancing Configuration Modifications | 14 |
| | 6. Mass Distribution Considerations | 15 |
| B. | SUPPORT STRUCTURE | 16 |
| C. | PROPULSION SYSYEM..... | 17 |
| | 1. Propulsion System Layout | 18 |
| | 2. Selection of Solenoid and Air Nozzles | 19 |
| | 3. Pressure Stabilization | 21 |
| D. | FLOATATION SYSTEM | 22 |
| E. | MECHANICAL DOCKING SYSTEM (MDS)..... | 23 |
| | 1. MDS Integration | 24 |
| | 2. MDS Operation | 25 |
| F. | REACTION WHEEL SYSTEM | 27 |
| | 1. Voltage Clamp Circuit..... | 28 |
| | 2. RWS operation | 29 |
| G. | POWER DISTRIBUTION SYSTEM | 30 |
| | 1. DC-DC Converter | 31 |
| | 2. Mechanical Relay Array..... | 31 |
| | 3. Component Power..... | 32 |
| | 4. Indoor GPS System..... | 33 |
| H. | SENSOR DECK | 34 |
| I. | SUPPORT EQUIPMENT | 35 |
| | 1. Air/Nitrogen Supply..... | 35 |
| | 2. Battery Recharging..... | 35 |
| III. | PERFORMANCE..... | 37 |

| | | |
|---------------------------|-------------------------------------------------|----|
| A. | CONTROLLER PERFORMANCE..... | 37 |
| B. | PROPELLANT EFFICIENCY | 38 |
| C. | POWER EFFICIENCY..... | 39 |
| D. | RELIABILITY AND TROUBLESHOOTING..... | 39 |
| 1. | Electrical Shorts | 39 |
| 2. | Stuck Solenoids | 40 |
| IV. | CONCLUSION | 41 |
| A. | SUMMARY | 41 |
| B. | FUTURE WORK..... | 41 |
| APPENDIX A | | 43 |
| A. | PARTS INFORMATION AND LIMITATIONS: | 43 |
| APPENDIX B | | 45 |
| A. | WARNINGS, CAUTIONS, AND NOTES: | 45 |
| APPENDIX C | | 47 |
| A. | PROCEDURES..... | 47 |
| 1. | Refilling the High Pressure Gas Cylinder: | 47 |
| 2. | Recharging Batteries: | 48 |
| 3. | Running Demonstrations: | 48 |
| APPENDIX D | | 51 |
| LIST OF REFERENCES | | 53 |
| INITIAL DISTRIBUTION LIST | | 55 |

LIST OF FIGURES

| | | |
|------------|--------------------------------------------------------------------------|----|
| Figure 1. | Engineering Test Satellite VII | 2 |
| Figure 2. | Orbital Express during soft docking | 3 |
| Figure 3. | Infrared LED target onboard target vehicle | 6 |
| Figure 4. | AUDASS II Vehicle | 9 |
| Figure 5. | AUDASS II Disassembled..... | 11 |
| Figure 6. | Mechanical Docking System Active Interface onboard AUDASS II..... | 12 |
| Figure 7. | 20.3 N.m.s Reaction Wheel onboard AUDASS II..... | 13 |
| Figure 8. | AUDASS I battery (left) and AUDASS II battery (right) | 14 |
| Figure 9. | AUDASS II Tank (left) and AUDASS I Tank (right) | 15 |
| Figure 10. | AUDASS II Floation/Propulsion Deck..... | 17 |
| Figure 11. | Propulsion System Schematic..... | 19 |
| Figure 12. | Thruster Unit (#4) onboard AUDASS II | 19 |
| Figure 13. | Plenum onboard AUDASS II..... | 22 |
| Figure 14. | Floation System Schematic | 23 |
| Figure 15. | Active Interface (front view) of MDS | 24 |
| Figure 16. | Chaser and Target in docking position | 25 |
| Figure 17. | Engagement Limit Switch..... | 26 |
| Figure 18. | Reaction Wheel Deck onboard AUDASS II..... | 27 |
| Figure 19. | Reaction Wheel Voltage Clamp Circuit Schematic..... | 28 |
| Figure 20. | Voltage Clamp Circuit..... | 29 |
| Figure 21. | Electronics Deck onboard AUDASS II | 30 |
| Figure 22. | Vicor DC-DC Converter array..... | 31 |
| Figure 23. | Schematic of relay integration into power distribution system | 32 |
| Figure 24. | Schematic of AUDASS II power distribution | 33 |
| Figure 25. | Wall mounted GPS Transmitter..... | 34 |
| Figure 26. | Sensor Deck onboard AUDASS II | 34 |
| Figure 27. | Rendezvous and docking demonstration commanded track..... | 37 |
| Figure 28. | Chaser vehicle response during rendezvous and docking demonstration..... | 38 |

THIS PAGE INTENTIONALLY LEFT BLANK

LIST OF TABLES

| | | |
|----------|-----------------------------------------------------|----|
| Table 1. | Characteristics of AUDASS II..... | 10 |
| Table 2. | Thrust output for various operating pressures. | 21 |
| Table 3. | Mass Properties..... | 51 |

THIS PAGE INTENTIONALLY LEFT BLANK

ACKNOWLEDGMENTS

The author would like to thank the following people for their invaluable assistance in the completion of this thesis:

The Air Force Research Laboratory in Albuquerque New Mexico for their financial support of this research.

The author would also like to thank the Defense Advanced Research Projects Agency for providing the Mechanical Docking Mechanism used on the vehicle that is the subject of this thesis.

The men and women at Marshall Space Flight Center in Montgomery Alabama, whose technical advice was crucial to success.

Professor Marcello Romano for his guidance.

Captain David Friedman, USAF, for his friendship and partnership in completing the AUDASS II vehicle.

THIS PAGE INTENTIONALLY LEFT BLANK

I. INTRODUCTION

A. BACKGROUND

1. Autonomous Rendezvous and Docking Research

Autonomous rendezvous and docking in space has been a topic of research for decades. To date, most efforts, and successes, in this area have involved spacecraft of high mass differentials, for example, Soyuz rendezvousing with the International Space Station (ISS). Additionally, in all previous cases of docking in space, there has been a human in the loop. In some cases, such as Gemini, the human actually conducted the maneuver. In other cases, such as Soyuz docking with the International Space Station, the human is used only to back up the system if there is a malfunction. Currently, research in this area involves unmanned spacecraft of lower mass conducting completely autonomous rendezvous and docking. Recent projects by the United States Air Force, National Reconnaissance Office (NRO) and the National Aeronautics and Space Administration (NASA) are exploring this area.

To date, the most informative mission of this type was the Engineering Test Satellite VII, “Kiku 7”, launched by the National Space Development Agency of Japan (NASDA) in November of 1997. During this mission, two vehicles were launched on a single booster and then separated when the proper orbit was achieved. After separation, the chaser spacecraft approached the target spacecraft and autonomously used a robotic arm to grasp the target spacecraft to initiate a soft docking. During this one-and-a-half year experiment many valuable lessons were learned regarding sensors and controls. Figure 1 shows Kiku-7. The larger spacecraft is the chaser; the robotic arm used to grapple the target spacecraft can be seen protruding from the bottom of the chaser.

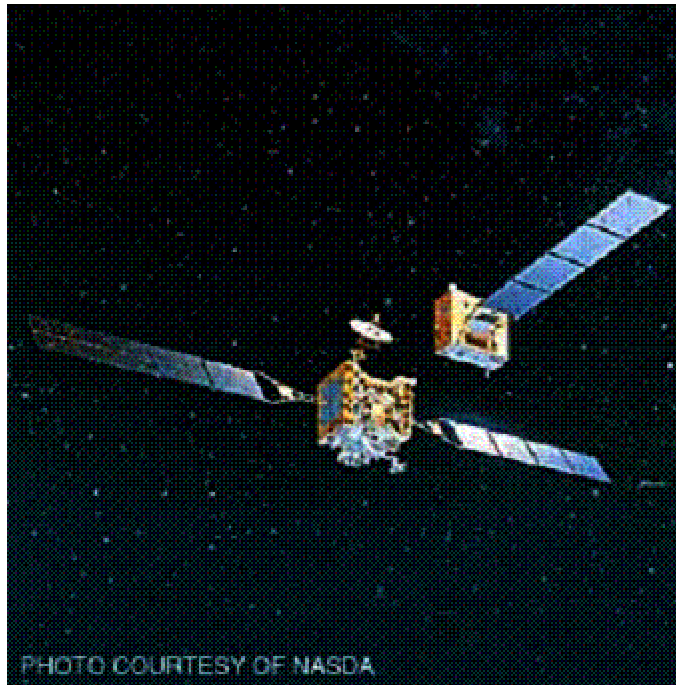

Figure 1. Engineering Test Satellite VII

Perhaps the most ambitious project thus far is the Orbital Express Demonstration. This project, funded primarily by the Defense Advanced Research Project Agency (DARPA) and partially by NASA, with Boeing as the primary contractor, will demonstrate on-orbit the rendezvous and docking of two unmanned spacecraft of similar mass (approximately 350 kg apiece) and conduct both fluid and data transfer. Additionally, various components on the target spacecraft will be replaced to demonstrate on-orbit spacecraft repair. During this demonstration, the chaser and target spacecraft will be launched on the same booster; once on orbit, the target spacecraft (NEXTsat) and the chaser spacecraft (ASTRO) will separate, positioning themselves some distance apart, and begin the demonstration. This mission is scheduled to be launched in 2006, with an expected four year duration. (Ref [1])

The Orbital Express demonstration is of particular interest because a scaled down prototype of the docking mechanism and receiver were given to the Naval Postgraduate School, Department of Mechanical and Astronautical Engineering by DARPA and have been integrated into the design of the vehicle that is the subject of this thesis (AUDASS II). Figure 1, below, shows a computer-generated image of the chaser spacecraft

(ASTRO), on the left, and the target vehicle (NEXTsat), on the right, just before docking. The docking mechanism is visible on the center of the interface of chaser spacecraft.

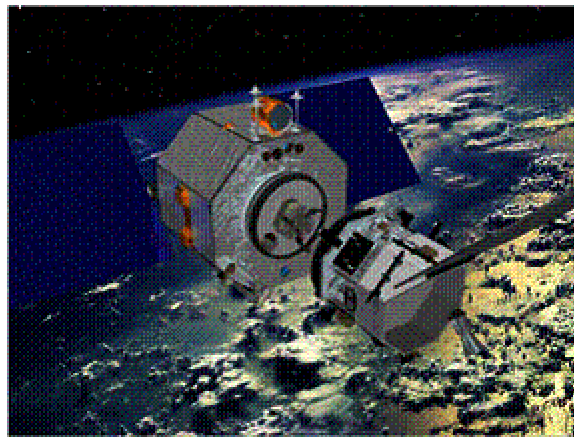

Figure 2. Orbital Express during soft docking

Upon successful completion of the Orbital Express demonstration by DARPA, it is anticipated that the spacecraft servicing effort will be handed to the Air Force for further development.

2. Similar Vehicles

In an effort to gain knowledge regarding the design of similar vehicles, a visit was made to NASA Space Flight Center, Montgomery Alabama, in March of 2005. At this facility, there is a test bed in which a vehicle, elevated on air bearings, uses cold gas thrusters to simulate autonomous rendezvous and docking on orbit. This vehicle is significantly larger than the vehicle fabricated during this thesis, with a mass of 1364 kg. Additionally, the NASA vehicle relies exclusively on thrusters for attitude control, while the vehicle in this thesis uses a combination of thrusters and a reaction wheel. However, despite the differences, valuable technical guidance was gained during the visit. For example, the NASA vehicle's configuration is different in that it only uses three air bearings, this is useful in that with just three air bearings there is no possibility that one of the air bearings will be off balance and slightly suspended from the floor, thus opening the gap between the air bearing and the floor, wasting fuel. Another valuable insight was gleaned from the fact that the NASA vehicle required a plenum to attenuate pressure

fluctuations during high thrust demand, this was an implementation that was eventually be required on the vehicle that is the subject of this thesis.

Another interesting effort is being made at Stanford University. There, a similar testbed has been created that allows a free-floating vehicle, with integrated grappling arms, to conduct research in the field of autonomous rendezvous and docking. This vehicle differs from the NASA vehicle primarily in its modular design. According to the designers, this has provided great benefits in the area of maintenance and modification. [Ref(7)] The modular nature of the Stanford vehicle is one that was followed in the design of the vehicle that is the subject of this thesis.

B. AUTONOMOUS DOCKING SPACECRAFT SERVICING SIMULATOR II

The goal of this research, which was sponsored by the Air Force Research Laboratory (AFRL), in Albuquerque, New Mexico, is to develop a spacecraft servicing simulator with the capability of conducting fluid transfer. This simulator will be able to validate various control algorithms and/or sensors that may be used to successfully conduct autonomous rendezvous and docking maneuvers.

1. AUDASS II Test Bed Concept

The Autonomous Docking and Satellite Servicing Simulator testbed consists of two completely independent vehicles, each free floating, via air bearings, on an epoxy floor. One vehicle is the “chaser”; the other is the “target”. Both vehicles are capable of two-dimensional translation in addition to rotation about one axis; thus, each has three degrees of freedom. The “chaser” contains the docking mechanism and the “target” contains the receiver for the docking mechanism. The “target”, known as Autonomous Docking and Spacecraft Servicing Simulator I (AUDASS I) (originally known as, Naval Postgraduate School Autonomous Docking Simulator, NPADS), was previously fabricated during research efforts conducted by Lieutenant Commander Robert Porter while pursuing a Master’s Degree in Astronautical Engineering from the Naval Postgraduate School in Monterey, California [Ref (2)]. The “chaser”, AUDASS II, is the subject of this thesis. AUDASS II uses thrusters that expel compressed nitrogen or air to achieve vehicle translation. Rotation is achieved via an onboard reaction wheel. An onboard camera, which is focused on infrared light emitting diodes (LED) located on the

“target”, in conjunction with an onboard inertial measuring unit (IMU) and control computer, is used for relative position determination and navigation. Power on the AUDASS II is provided via two lithium ion batteries.

Upon initiation of a demonstration, AUDASS II autonomously locates the “target” vehicle, and determines its position and attitude relative to it. Then, using thrusters to attain translation and the reaction wheel to control rotation about the vertical axis, navigates to a specific position in front of the “target” vehicle. After successful rendezvous, AUDASS II deploys a docking mechanism that engages the docking mechanism receiver onboard the “target” vehicle. Upon proper engagement, the two vehicles are docked and capable of conducting fluid transfer.

Additionally, an indoor Global Positioning System was set up in to accurately ascertain the actual position and motion of the vehicle for later comparison against the estimated position from the onboard IMU. Currently, this system is still in development and is not used during the demonstration.

2. Vehicle Position Determination

While operating, the vehicle uses two separate computers, one for control and one for vision/position determination. The vision computer uses Windows 2000 as an operating system and Matlab for computation. The vision computer accepts data from a camera mounted on the Sensor Deck. The camera is pointed at an array of three infrared LEDs onboard the target vehicle, they are configured in such a way that distance from, and position relative to the target may be computed. The three LEDs are lined up vertically, with about six cm between them, the middle LED is additionally set forward 10 cm from the other two. The vision computer, knowing the geometry of the LED configuration, is able to determine the position of the vehicle relative to the target. This information is sent to the control computer for input into the control algorithm.

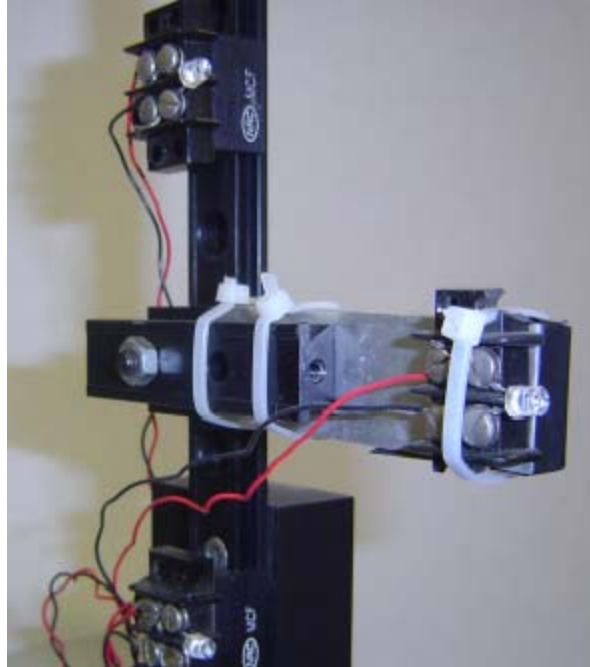

Figure 3. Infrared LED target onboard target vehicle

3. Vehicle Control

The vehicle's control computer uses Mathworks XPC-Target as an operating system and C for computation (after being converted from Simulink). The controller uses inputs from the vision computer for position and the onboard IMU for acceleration and velocity. With, these two inputs, the controller uses a Schmidt Trigger type controller, and pulse width modulation to operate the thrusters. During normal operation, all translation is accomplished via the thrusters.

The attitude (angle about the vertical axis) of the vehicle is controlled using a PD type controller that commands the reaction wheel. During normal operation, all rotation about the vertical axis is accomplished with the reaction wheel.

The IMU is critical to the control system, particularly the Kalman filter, which is used for position estimation when the LEDs are not in the camera's field of view. The IMU is powered by the vehicle's power distribution system. Extra care was taken to place the IMU directly over the vehicle's center of mass, which is coincident with the center of rotation, in order to mitigate any "lever effect".

4. Scope of Thesis

This thesis involves the design, fabrication and system integration of the AUDASS II vehicle. After determining the concept of operations for the test bed, the initial design was created. Secondly, various subsystem components were selected and purchased. These components were chosen by considering, among other things, performance, mass, ease of integration, compatibility with other subsystem components and cost. After fabrication, the vehicle was then integrated with the control and vision computers. Subsequent performance evaluation was conducted to improve the design and determine various performance specifications. Additionally, various servicing, safety and operational procedures were created to aid future users in properly operating the vehicle.

A fellow Master's Degree Astronautical Engineering student, Captain Dave Friedman USAF, is authoring a thesis that specifically addresses issues such as the set up of the testbed and the control of the AUDASS II vehicle [Ref (4)].

THIS PAGE INTENTIONALLY LEFT BLANK

II. AUDASS II DESIGN

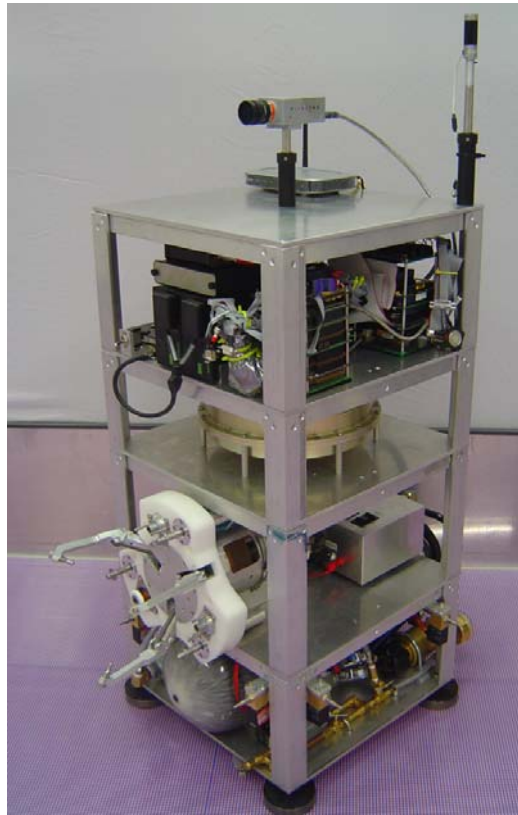

Figure 4. AUDASS II Vehicle

| | Parameter | Value |
|--------------------------|------------------------------|-------------------|
| Physical Size | Length [cm] | 40 |
| | Width [cm] | 40 |
| | Height [cm] | 85 |
| | Mass [Kg] | 62.9 |
| Propulsion | Thrusters Type | Cold-Gas |
| | Propellant | Air or Nitrogen |
| | Storage Capacity [liters] | 2460 @ 1 ATM |
| | Operating Pressure [Atm] | 3.4 – 6.8 |
| | Continuous Operation [min] | ~ 20 |
| | Thrust of each thrusters [N] | .58 |
| | RW Max Torque [Nm] | 0.1624 |
| | RW Max Ang. Mom. [Nms] | 20.3 |
| Electrical System | Battery Type | Lithium-Ion |
| | Storage Capacity | 12 Ah @ 28Vdc |
| | Continuous Operation | ~ 6 h |
| | Regulated Voltages | 5, 18, 20, 24 Vdc |

| | | |
|--------------------------------------------|--------------------|-----------------------|
| Vision and Control Computers System | Computers | PC104 |
| | Processors | Pentium III |
| | Operating Systems | Win2000 XPC Target |
| | Input/Output Cards | Firewire, A/D |
| Sensors | IMU | |
| | Indoor GPS | |
| | Vision Sensor | |

Table 1. Characteristics of AUDASS II

A. CONCEPT DEVELOPMENT

During the concept development phase of AUDASS II, the previously mentioned AUDASS I vehicle, developed by Lieutenant Commander Robert Porter, was considered the baseline design. This was due to the fact that eventually both vehicles would have to interact during rendezvous and docking. Consequently, a vehicle of similar geometry and mass was desirable. Other design requirements included: modularity, greater endurance, both in propellant and power consumption, the addition of a larger reaction wheel for greater attitude authority, and the addition of the docking mechanism. The challenge was to add the more massive reaction wheel and docking mechanism while at the same time increasing the vehicles endurance and still maintain approximately the same mass and dimension of the original NPADS vehicle. Elaboration on the various aspects of the concept development follows.

1. Modularity

One of the key requirements for AUDASS II was modularity. That is, to fabricate each vehicle level independently and place all or most of a single subsystem's components on a single level. This allows for flexibility in the configuration. For instance, the ability to add levels and associated subsystem components to the vehicle at a later date without having to disassemble the entire vehicle. The modular design of the vehicle also proved beneficial during maintenance and repair. One disadvantage of the modular design is added complexity and mass of the vehicle's support structure. Although, this added difficulty to the fabrication of the support structure, it was well worth the advantages that were derived from the modular design.

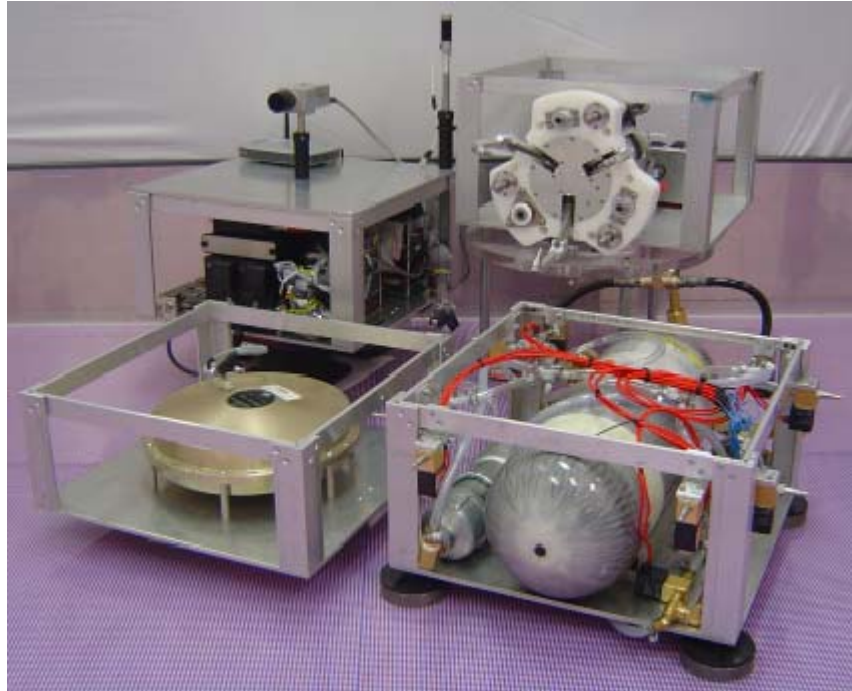

Figure 5. AUDASS II Disassembled

2. Docking Mechanism Integration

The primary purpose of the development of AUDASS II was to demonstrate autonomous rendezvous and docking. Fortunately, the Spacecraft Robotics Lab was able to acquire a docking mechanism and receiver from the Defense Advanced Research Projects Agency. This docking mechanism, which was developed by the Starsys Corporation, is the actual scaled down prototype of the docking mechanism that is going to be used for the Orbital Express Demonstration mission. Because the docking mechanism is the single most important subsystem on the vehicle, it was the main driver in the design of the vehicle. For example, the decks were required to be able to physically accommodate the docking mechanism and its control box. This constraint determined the overall dimension of the vehicle.

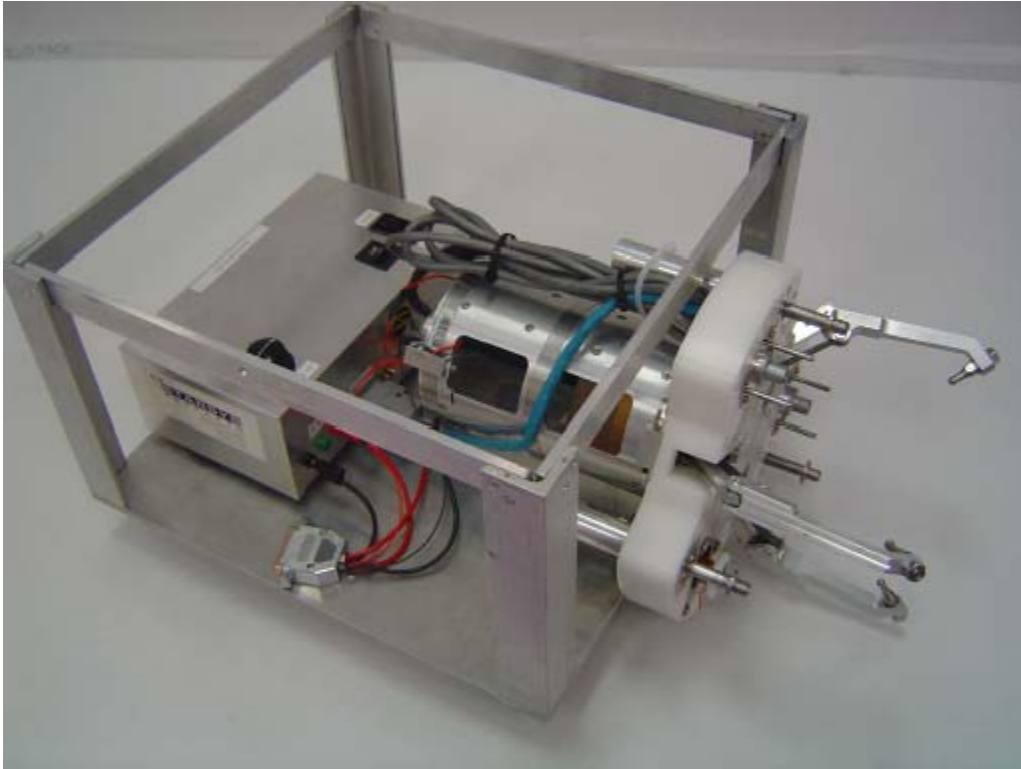

Figure 6. Mechanical Docking System Active Interface onboard AUDASS II

3. Reaction Wheel Upgrade

The addition of a larger reaction wheel was determined to be necessary after operational testing of the AUDASS I vehicle. During testing, it was determined that the reaction wheel used on that vehicle provided inadequate torque to allow sufficient attitude authority. Because AUDASS II was going to be of similar size and mass, it was anticipated that the same problem would develop. The Spacecraft Robotics Lab had a larger reaction wheel in its inventory. This larger reaction wheel, built by Ball Aerospace, provided a maximum angular momentum of 20.3 N-m-s as opposed to the 2.5 N-m-s maximum provided by the reaction wheel onboard AUDASS I. Of course, the larger reaction wheel has a greater mass. The reaction wheel used on AUDASS I has a mass of 3.2 kg while the proposed reaction wheel for AUDASS II has a mass of 9.07 kg. This mass differential had to be compensated for by reducing mass in some other subsystem of the vehicle.



Figure 7. 20.3 N.m.s Reaction Wheel on board AUDASS II

4. Performance Enhancing Component Selection

The mass of the AUDASS II vehicle is required to be similar to that of the AUDASS I vehicle. This is made difficult by the addition of both the heavier reaction wheel and docking mechanism. In order to reduce mass, various components were selected with mass reduction in mind.

A significant component improvement on AUDASS II was the selection of Lithium Ion batteries as the power source. The AUDASS I vehicle used traditional lead acid batteries. These lead acid batteries have a mass of 6.7 kg, using two, the mass of the AUDASS I power supply is 13.7 kg. The AUDASS I vehicle wired its batteries in series. Together the batteries are rated for 10 Ah at 24 volts. The Lithium Ion batteries chosen for AUDASS II have a mass of 1.36 kg each, for a combined mass of 2.72 kg. The AUDASS II vehicle's batteries are wired in parallel, together they are rated for 12 Ah at 30 volts. Thus, the addition of these batteries to the AUDASS II design has allowed for a reduction in mass while increasing the power available.



Figure 8. AUDASS I battery (left) and AUDASS II battery (right)

Another component improvement was the selection of carbon fiber tanks for the propellant and float gas supply. The AUDASS I vehicle uses two traditional aluminum diving tanks with a service pressure of 207 bar. Each tank has an empty mass of 3.7 kg , for a combined mass of 7.4 kg. Each tank has a capacity of 563.6 liters, for a combined capacity of 1127.2 liters. For AUDASS II, a single carbon fiber tank was selected. This tank has a service pressure of 310 bar and an empty mass of 5.3 kg. Its maximum air capacity is 2460 liters. Therefore, the new tank provides 118% more air capacity with a mass reduction of 2.1 kg. This is beneficial to both increasing endurance and reducing mass.

5. Performance Enhancing Configuration Modifications

One significant configuration change to the original AUDASS I vehicle was implemented on AUDASS II to increase vehicle endurance. AUDASS I used two independent air supplies for propulsion and floating. This is an inefficient method. After testing propellant usage by both the thrusters and the air bearings, it was determined that during normal operation, station keeping, for example, the thrusters consumed

approximately 10 times the propellant as the air bearings. However, on AUDASS I, the air supply to the thrusters and the air bearings are the same quantity. This configuration caused the thrusters to be under supplied while the air bearings were over supplied. This caused the necessity to frequently recharge the thruster air supply. On AUDASS II both the air bearings and the thrusters feed off the same single air supply, consequently, both systems take what they need and the necessity for recharging is reduced, in essence, increasing endurance.



Figure 9. AUDASS II Tank (left) and AUDASS I Tank (right)

6. Mass Distribution Considerations

Special consideration was given to the location of the center of mass of the vehicle. Components were specifically placed in an attempt to keep the center of mass as close as possible to the symmetry axis of the vehicle. For instance, in order to

compensate for the forward placement of the docking mechanism's active interface, the regulators for the propulsion and floatation system were placed aft on the vehicle. These, and other similar, manipulations were required in order to keep the center of rotation coincident with the IMU, which is aligned with the symmetry axis.

B. SUPPORT STRUCTURE

The primary support structure of AUDASS II is composed of 6061 Aluminum $\frac{1}{4}$ inch sheet, $1\frac{1}{2}$ inch x $1\frac{1}{2}$ inch x $\frac{1}{4}$ inch 6061 Aluminum L bar and 1 inch x $\frac{1}{4}$ inch flat bar. The structure of each module is composed of a base plate of dimension 40 cm x 40 cm with $\frac{1}{4}$ inch thickness. At each of the corners of the base plate, the L bars are placed vertically and held in place from beneath by two M6-32 $\frac{1}{2}$ inch screws countersunk into the underside of the module base plate. The tops of the vertical L bars are cross connected by 1 inch x $\frac{1}{4}$ inch flat bar. These top crossbeams were necessary to strengthen the module structure against torque loads about the vertical axis, as the top of the vertical supports of one module are not connected to the module above it. Essentially, the support structure of each module is shaped like a box, and the vehicle itself is a stack of these modules. The L bars of each module support all vertical loads, until the load is carried to the bottom base plate of the vehicle. The vehicle base plate rests upon four air bearings. The air bearings are fitted with a ball joint to a $\frac{1}{4}$ inch bolt, this bolt protrudes through the underside of the base plate at a position directly between the outer tips of the L bar vertical support. This close proximity to the L bar support prevents deflection of the base plate.

C. PROPULSION SYSEM



Figure 10. AUDASS II Floatation/Propulsion Deck

The AUDASS II propulsion system is composed of a Carbon Fiber tank, two variable pressure regulators, braided vinyl tubing, a plenum, eight solenoids, and eight air nozzles. The propulsion system is primarily responsible for the translation of the vehicle. The requirements for the design of the propulsion system for AUDASS II were similar to that of AUDASS I, this is due to the fact that the vehicles share similar mass, dimensions and performance requirements. There are various enhancements in the AUDASS II design. For instance, the previously discussed selection to use one common tank for both the propulsion system and float system. Another upgrade is the use of solenoids, tubing and variable output pressure regulators that allow the propulsion system to be operated at pressures from 0 bar up to 8.61 bar (125 psi). This ability to easily manipulate the working pressure of the propulsion system will be useful as the vehicle evolves in the

future. Additionally, it should be noted that the system is capable of operating with both Nitrogen and air.

1. Propulsion System Layout

The propulsion system consists of a Carbon Fiber Gas Cylinder, with a maximum service pressure of 310.2 bar (4500 psi), which feeds two variable output regulators capable of regulating pressure from 0 to 27.6 bar (400 psi). One regulator supplies the propulsion system while the other supplies the float system. After the propulsion regulator, the reduced pressure nitrogen or air is fed to a plenum, manufactured from galvanized steel pipe, which is used to attenuate pressure fluctuations during high thrust use. After the plenum, the pressurized nitrogen is fed to the normally closed solenoid component of each thruster assembly.

For additional propulsion system flexibility, a cross feed from the floatation regulator was created. This cross feed has a valve that is closed during normal operation. If the vehicle has a high thrust demand, it is recommended to open the cross feed valve in order to allow the regulators to work in parallel. This configuration will allow for a constant pressure head even during the highest possible rated airflow from the thrusters. However, this will require that both regulators be equally set, consequently, the supply to the air bearings will be the same pressure as the thruster pressure. Below is a schematic diagram of the Propulsion System.

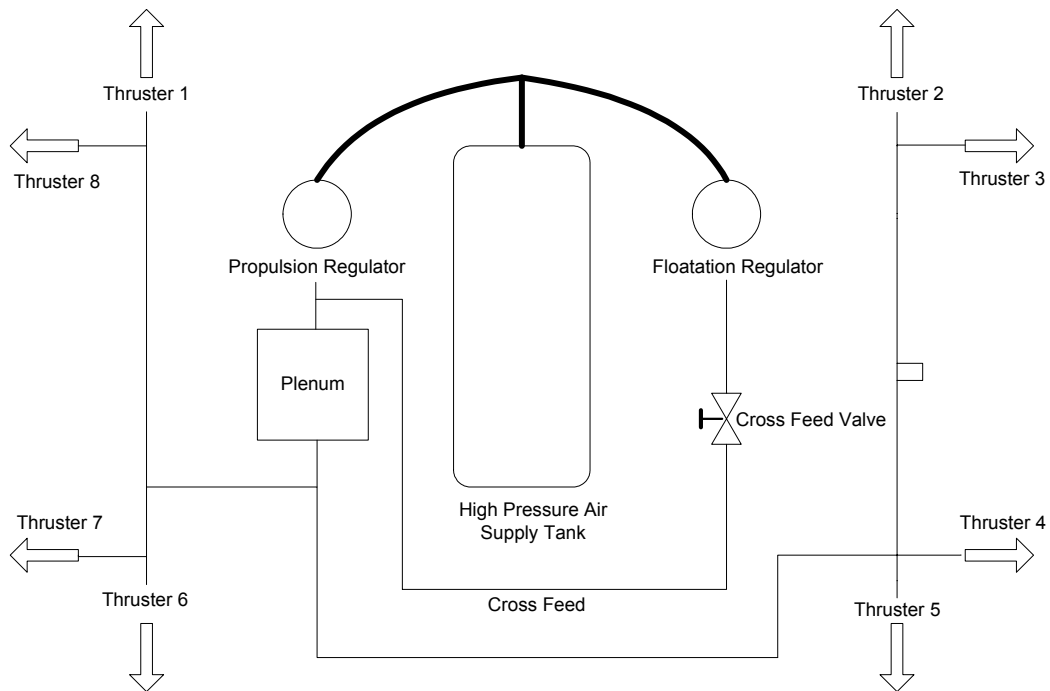

Figure 11. Propulsion System Schematic

2. Selection of Solenoid and Air Nozzles



Figure 12. Thruster Unit (#4) onboard AUDASS II

Selection of the air nozzles was done by experimenting with various combinations of air nozzles and solenoids to determine which gave the most thrust per unit airflow, essentially, efficiency. This evaluation was done for various operating pressures. Efficiency was important, as it contributed to vehicle endurance, but had to be considered in conjunction with provided thrust. Experimentally, some of the most efficient combinations happened to lie in the lowest thrust range. This was useless as it was anticipated that the most common operating range would be in the 5 to 8 bar region. Therefore, the 5 to 8 bar operating pressure region was used for testing.

Testing involved using various solenoids that had different diameter orifices in combination with various industrial air nozzles. Each thruster configuration was subjected to input pressures of both 5 and 8 bar while placed on a digital scale; the digital readout gave the subsequent measurement of thrust. Prior to each configuration test, the supply tank pressure was measured, after the thruster was fired for 30 seconds, the supply tank pressure was again measured, knowing the volume of the tank, a determination of the amount of air used per unit time could be made. This was the method used for determining thruster efficiency. After testing, the optimal combination proved to be the Silvent MJ5 nozzle in combination with the Asco U 8225B002V solenoid. This configuration is rated to operate at 8.6 bar. In comparison with the thruster configuration used on AUDASS I, this thruster configuration produces the same thrust at half the working pressure. Consequently, if needed, the thrusters may be operated at the maximum allowable pressure to produce over twice the thrust as the thrusters used on AUDASS I. Below is a table illustrating the various thrust outputs for a given operating pressures.

| Operating Pressure | Thrust Output |
|--------------------|-----------------|
| 1.38 bar (20 psi) | .18 N (.04 lbs) |
| 2.07 bar (30 psi) | .31 N (.07 lbs) |
| 2.86 bar (40 psi) | .44 N (.10 lbs) |

| | |
|--------------------|------------------|
| 3.45 bar (50 psi) | .58 N (.13 lbs) |
| 4.14 bar (60 psi) | .85 N (.19 lbs) |
| 4.83 bar (70 psi) | .89 N (.20 lbs) |
| 5.52 bar (80 psi) | .98 N (.22 lbs) |
| 6.89 bar (100 psi) | 1.25 N (.28 lbs) |

Table 2. Thrust output for various operating pressures.

3. Pressure Stabilization

During initial testing, it was discovered that during periods of maximum thrust demand the propulsion system pressure would drop, temporarily, to about 50 percent of the set pressure value. This is unacceptable, as the controller requires constant thrust available. Various solutions were attempted to solve the problem. Initially, an extra supply tank was placed in the propulsion system, passed the regulators, however, because the orifice into the tank for the entering nitrogen was too small, the flow was constrained. Consequently, the idea did not work satisfactorily. The next solution was to integrate a cross feed from the floatation supply regulator to the propulsion system side. This idea rendered acceptable results, however, it had drawbacks. Chief among them was the fact that, in this configuration, the floatation system and the propulsion system have to operate under the same pressure. This, in and of itself, is not detrimental to performance, except that it causes a greater nitrogen flow to the air bearings than is necessary, thus decreasing efficiency. The ultimate solution was to manufacture a plenum. The plenum was created by fitting a 12 cm long pipe with a 5 cm diameter, into the system, after the regulators. The plenum has openings that are the same size as the inner diameter of the supply hose. This allows the nitrogen to flow in and out of the plenum unconstrained. This solution solved the problem. During normal operation (at 3.5 bar), with the floatation and propulsion systems operating independently (Cross Feed Valve in closed position), there is less than a .34 bar drop in propulsion system pressure, even during maximum demand. This drop can be further reduced by operating the floatation system

and the propulsion system in parallel (Cross Feed Valve in open position). However, as previously mentioned, this will cause the necessity to operate the air bearings at the same pressure as the propulsion system.



Figure 13. Plenum onboard AUDASS II

D. FLOATATION SYSTEM

The floatation system is comprised of a Carbon Fiber gas cylinder, variable output pressure regulator, braided nylon tubing, brass piping, a solenoid, a manual bypass valve, and air bearings. The gas cylinder feeds the variable output regulator. From the regulator, the nitrogen flows to a solenoid assembly. The solenoid assembly is wired to an electric switch that enables the control computer to activate the solenoid. When the normally closed solenoid is energized, the pressurized nitrogen is allowed to flow, to the air bearings and the vehicle floats on a cushion of nitrogen. The solenoid assembly also contains a bypass valve, known as the “Float Bypass Valve”, to allow operation of the floatation system without the necessity of energizing the solenoid. Below is a schematic of the floatation system.

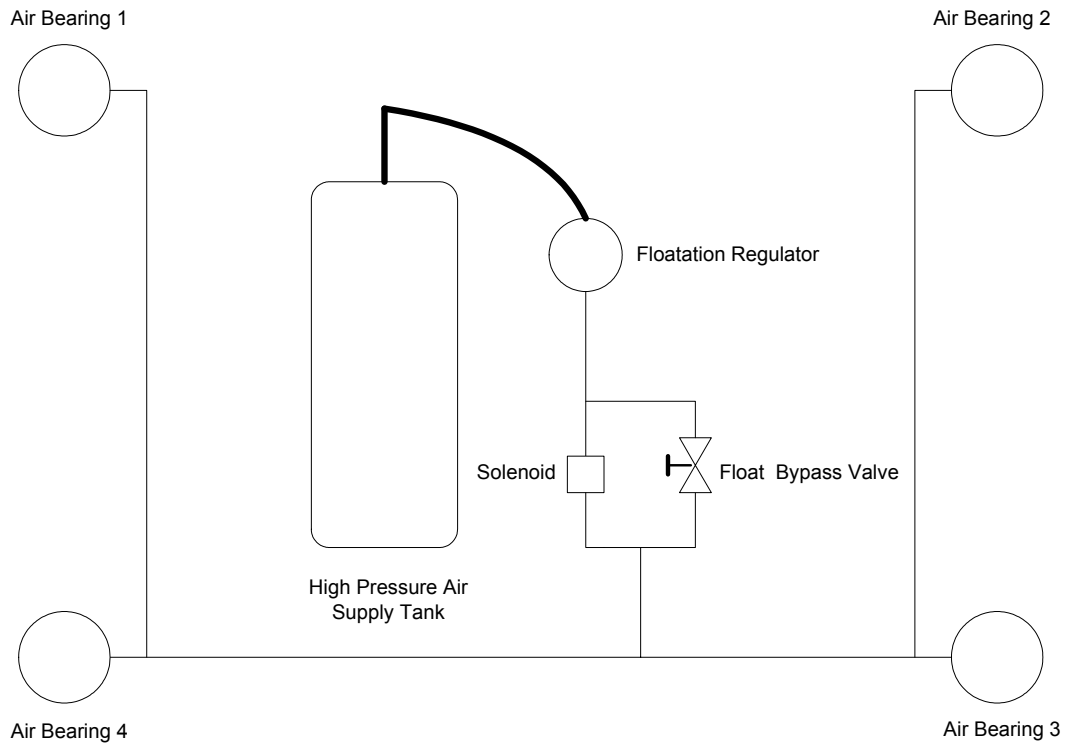

Figure 14. Floatation System Schematic

E. MECHANICAL DOCKING SYSTEM (MDS)

The Mechanical Docking System consists of three fundamental parts, the Active Docking Interface, the Passive Docking Interface and the controller. The MDS is a scaled down prototype of the actual unit that is onboard Orbital Express, scheduled to be launched in late 2006. Created by Starsys Research in Boulder Colorado, the MDS is designed to allow soft docking with the capability to conduct cryogenic fluid and data transfer. The Naval Postgraduate School was able to acquire the unit through the courtesy of the Air Force Research Laboratory in Albuquerque, New Mexico, which is the sponsor of this research.

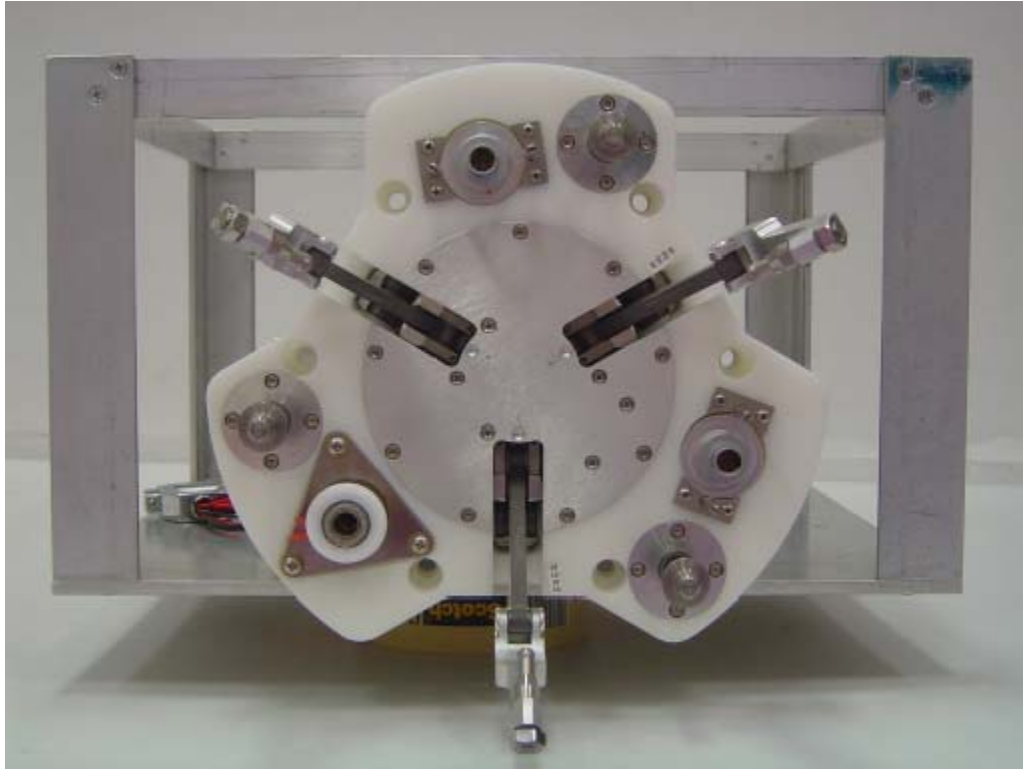

Figure 15. Active Interface (front view) of MDS

1. MDS Integration

The MDS Active Interface was required to be mounted to the front of the chaser vehicle. Consequently, this shifted the center of mass of the vehicle forward. It is for this reason that the regulators were positioned on the aft portion of the vehicle, this allowed a counter to the forward position of the MDS Active Interface. The Active Interface motor housing sits in a cradle with the grapple arms protruding forward off the front face of the chaser vehicle. The Passive Interface is mounted to the forward face of the target vehicle at the same height. The control unit for the MDS is mounted on the chaser vehicle directly behind the Active Interface. The control unit receives power from the vehicle power source and distributes it to the Active Interface, the Passive Interface does not require power.

It was necessary to add the Passive Interface to AUDASS I. This was done by fabricating a set of brackets that were used to attach it to the front of the target vehicle. There are no electrical inputs to the Passive Interface so the integration was simple.



Figure 16. Chaser and Target in docking position

2. MDS Operation

The Mechanical Docking System requires inputs of 20 volts, 20-30 volts and two voltages for the deployment and the engagement of the grapple arms. When commanded to engage, the Active Interface engages an electric motor that turns a worm gear that causes a piston to move forward (Deployment) or aft (Engagement). The movement of the piston allows the grapple arms to either, extend and expand (deployment) or to contract and recede (engagement). Because the MDS was not designed to be commanded by any other source except the control unit itself, a simple modification to the control unit's electronics had to be implemented in order to allow the Active Interface to be commanded by the control computer onboard AUDASS II. This modification involved opening the control unit and adding wiring to the manual switch that would allow voltage to be brought to the switch from the vehicle power source vice the control unit itself. This configuration allows for both manual operation and computer commanded operation of the Active Interface.

According to the manufacturer of the MDS either full engagement of full deployment of the Active Interface could permanently damage the mechanism.

Therefore, the Active Interface had to be modified to include a limit switch to prevent full engagement (full deployment was not guarded against because it was determined to be highly unlikely). This was done by adding a normally closed pushbutton switch to the aft end of the motor housing. When the worm gear driven piston contacts the switch, the normally closed switch opens and deenergizes the “engagement” circuit, thus ceasing the engagement and preventing full throw of the piston against the stop. It should be noted that the switch only affects relay activated engagements, it is still possible to manually overengage the unit by using the manual engagement switch atop the control box. Specifics regarding the MDS electric circuit may be found in the electronics chapter of this thesis.

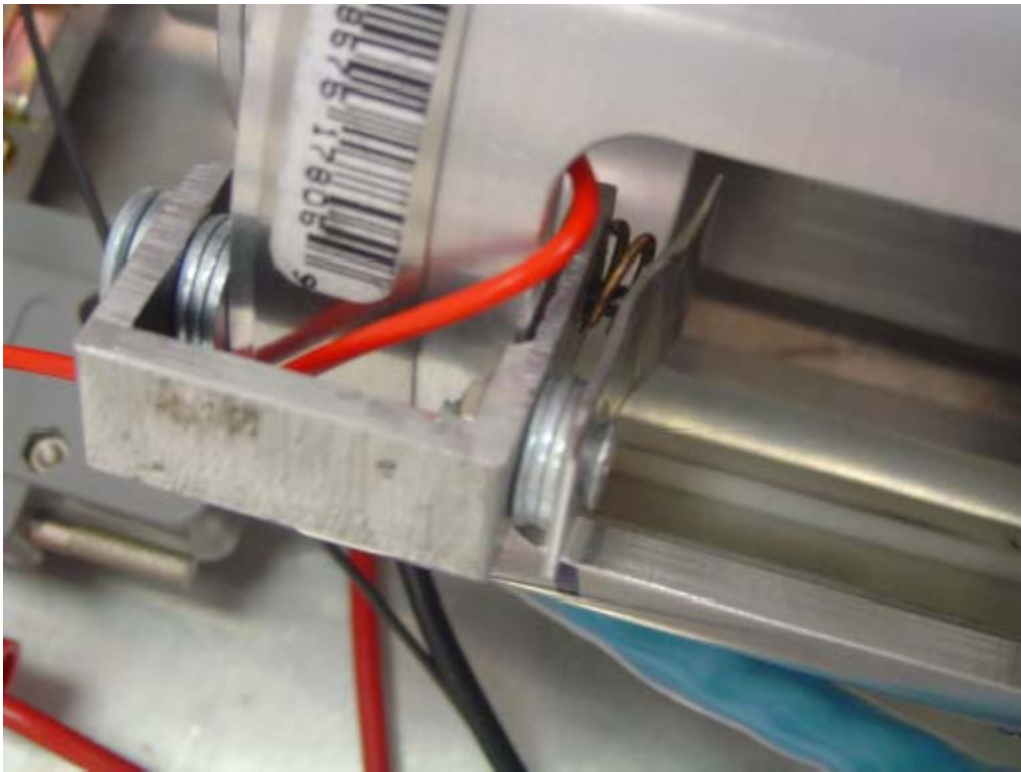

Figure 17. Engagement Limit Switch

F. REACTION WHEEL SYSTEM



Figure 18. Reaction Wheel Deck onboard AUDASS II

The reaction wheel system is composed of a ± 20.3 N-m-s reaction wheel and a voltage clamping circuit. The reaction wheel is used to control attitude about the vertical axis. This is advantageous for three fundamental reasons. First, the controller does not have to split time on the thrusters between the control of three degrees of freedom, with the reaction wheel controlling the attitude; the thrusters are only obligated to translation. Consequently, the translation control has higher bandwidth. Likewise, with the reaction wheel providing full time control of attitude, the attitude control also has higher bandwidth. Additionally, with less demand on the thrusters, less propellant is used, resulting in greater vehicle endurance. Because the reaction wheel is powered by the vehicle power source, the endurance of the power supply is now lower. However, the overall vehicle endurance is limited by the propellant consumption, not the power consumption. Therefore, the overall vehicle endurance is improved with the operation of the reaction wheel.

1. Voltage Clamp Circuit

One problem encountered while using the reaction wheel is a regeneration phenomenon. Regeneration is the return of energy stored in the rotating flywheel to the reaction wheel power supply. This problem was first encountered during the fabrication of the AUDASS 1 vehicle [Ref (2)]. Essentially, when a command is given to the reaction wheel to reverse torque, a back EMF is generated that, depending on the speed of the wheel and magnitude of the counter torque command, can be substantial. This back EMF is sent into the vehicle power supply and can cause substantial damage to the vehicle and reaction wheel. The solution to this problem is to add a voltage clamping circuit. If a substantial back EMF is created, this circuit diverts it to ground thus preventing it from entering the vehicle's power supply. The voltage clamping circuit is relatively simple. It is composed of two diodes, two resistors and a "Darlington Transistor" (TIP 142).

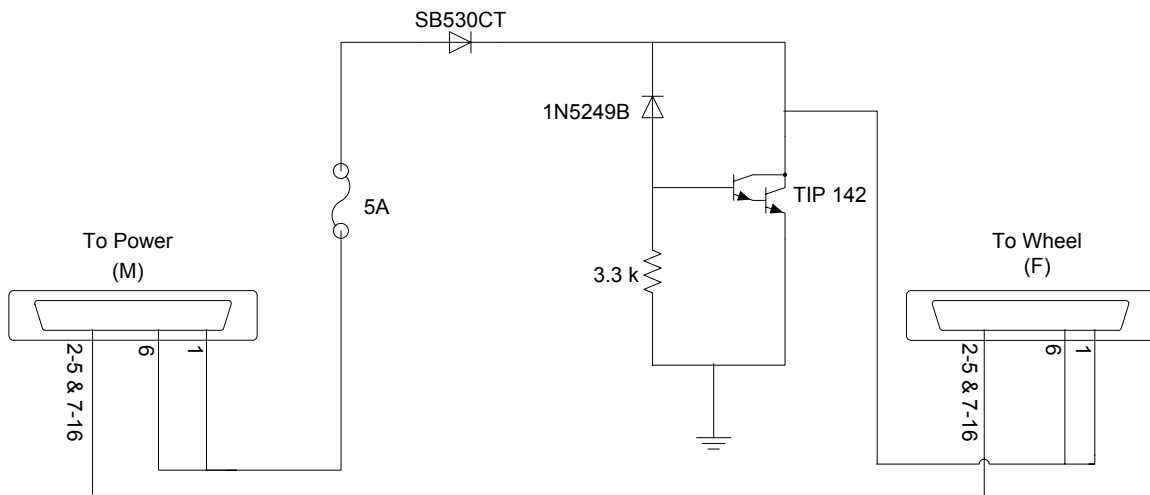

Figure 19. Reaction Wheel Voltage Clamp Circuit Schematic

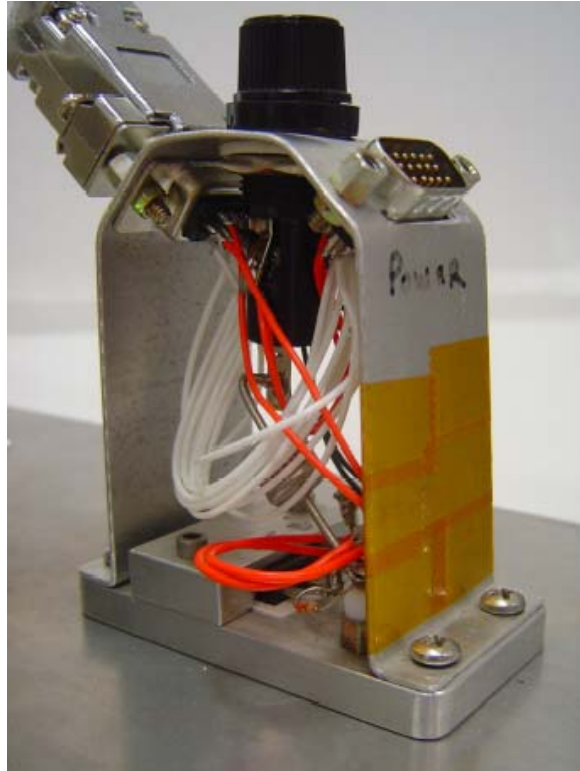

Figure 20. Voltage Clamp Circuit

2. RWS operation

The reaction wheel, manufactured by Ball Aerospace, is capable of an angular momentum of 20.3 N-m-s at 2500RPM. It can produce torques of +/- 162.4 mN-m (@2500 rpm) [Ref (3)]. An analog torque command of +/- 2 volts is sent to the wheel from the analog input/output board of the control computer. Hall sensors, within the reaction wheel housing, are used to create signals that are sent to the analog input/output board for the determination of rpm. Power is provided by the vehicle power supply. The reaction wheel operates at 18 volts and uses 16.5 watts when maintaining 2500 rpm, 80 watts during the application of maximum torque.

The AUDASS II vehicle uses the reaction wheel at lower operating speeds than the user manual addresses. For example, when a demonstration begins the reaction wheel has no velocity. Only after the wheel receives its first torque command will it attain velocity. This has two advantages. First, the reaction wheel is not required to consume power in order to achieve and maintain a high rpm, power usage is only required when a torque is commanded. Secondly, because the wheel requires time to spin up (110 seconds

to 2500 rpm) and spin down (845 seconds from 2500 rpm to 0 rpm) [Ref (3)], demonstrations can be run in a more timely fashion.

G. POWER DISTRIBUTION SYSTEM



Figure 21. Electronics Deck onboard AUDASS II

Power to the AUDASS II vehicle is provided by two Lithium Ion batteries. Each battery contains two cells; these cells are wired in series, this allows each battery to be operated in the 28 volt mode. Then the two batteries are wired in parallel, thus providing 28 volts to the vehicle. After the batteries are wired together in parallel, the positive lead is sent through an inline 10 amp fuse, then to a manual switch. After the switch, the two leads are connected to a four-output DC-DC converter array, where the 28 volts is converted to 5 volts, 20 volts, 18 volts, and 24 volts. Some components are wired directly to the DC-DC converter, such as the IMU, the two computers, the reaction wheel. Other components, such as the thruster solenoids, the engagement and deployment circuits of the Mechanical Docking System, the floatation activation solenoid and two electromechanical relay boards are wired to a bus after the DC-DC converter.

1. DC-DC Converter

The Vicor Corporation manufactures the DC-DC converter array used on AUDASS II. The converter has four outputs, one 5 volt and three 24 volt. These outputs were customizable upon ordering the unit. The outputs can be trimmed by adding resistors to the converter circuit (up 10% and down 90%) [Ref (5)]. It should be noted that trimming the outputs with resistors degrades the efficiency of the unit. Ideally, the output of the converter will be as close as possible to the required voltage. The procedure for trimming is outlined in the in the technical manual for the converter, or on the company's website (provided in Appendix A). In this case, the step down from 24 volts to 18 volts required the integration of a 3 k ohm resistor, and the step down from 24 volts to 20 required a 5 k ohm resistor.

The DC-DC converter array was ordered with an attached cold plate, this allows efficient heat transfer from the converters to the electronics deck base plate. This proved satisfactory for moderating the temperature of the array.

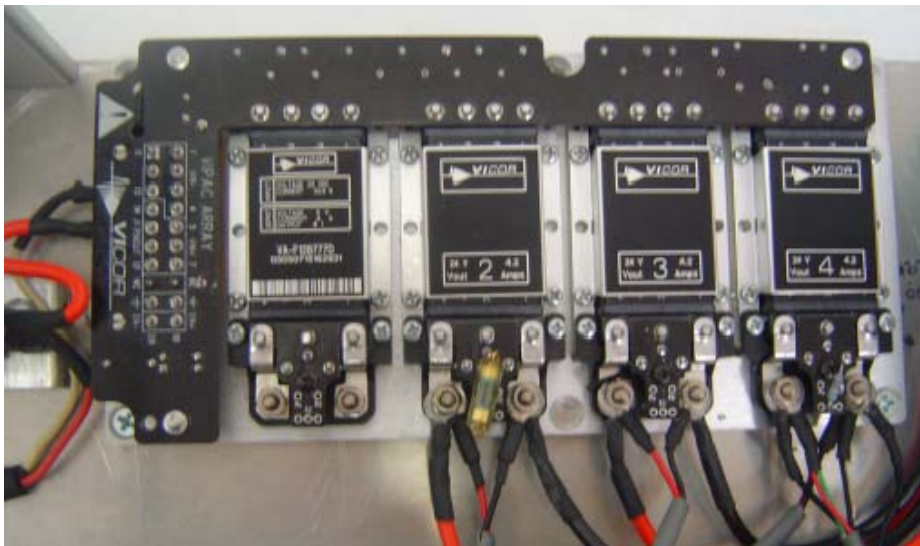

Figure 22. Vicor DC-DC Converter array

2. Mechanical Relay Array

The Mechanical Relay Array is manufactured by RTD Embedded Technologies. This relay array provides computer control over various mechanisms onboard AUDASS II, for example, all eight thruster solenoids, the floatation activation solenoid, and the engagement and deployment of the docking mechanism. There are two mechanical relay

arrays, with eight individual relays on each array for a total of 16 relays. Simply put, the relay closes a circuit when a command is given, thus allowing current to flow. In this case, the signal is received from the digital input/output board on the control computer. When received, the relay will close, allowing the operation of the associated mechanism. The relay array requires +5 volts for operation, this power is provided from the computer power supply. A general schematic of the relay and its associated circuit are provided below to illustrate the manner in which it was integrated into the vehicle.

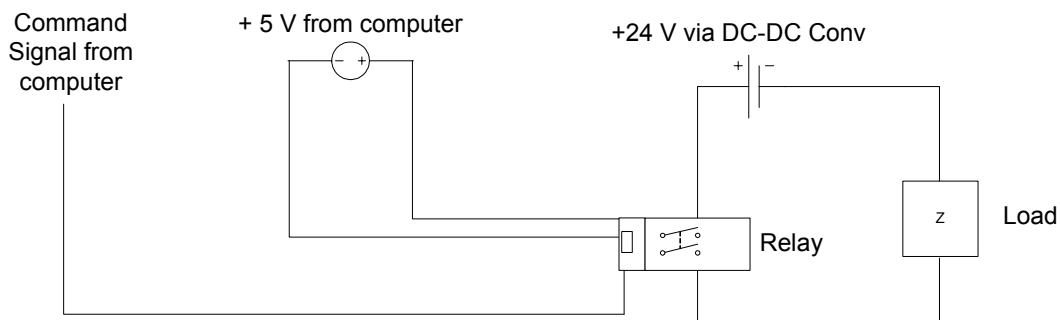

Figure 23. Schematic of relay integration into power distribution system

3. Component Power

Various components are powered from the computer's power supply. For example, the camera is powered by the vision computer's power supply and both relay boards receive their required +5 volts from the control computer. Therefore, no integration of these components into the vehicle power supply system was required. Below is a schematic of the power distribution system.

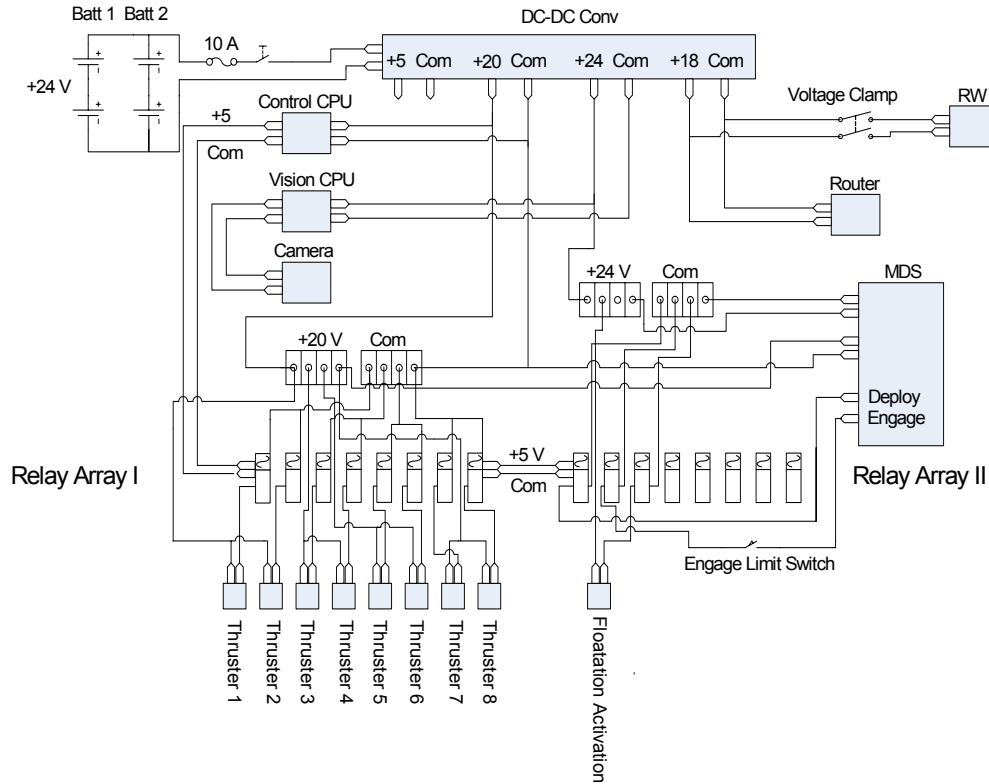

Figure 24. Schematic of AUDASS II power distribution

4. Indoor GPS System

The AUDASS II vehicle is equipped with an indoor GPS. This system requires two transmitters, which are mounted to the wall in the lab. The wall-mounted transmitters transmit a vertical fan shaped beam of eye-safe laser energy, the antenna on the sensor deck of the vehicle receives both signals and is able to determine its position in three dimensional space through triangulation. This system uses its own power source, a rechargeable battery, therefore no integration into the vehicle's power supply was needed.



Figure 25. Wall mounted GPS Transmitter

H. SENSOR DECK

The sensor deck is simply a single 40 cm x 40 cm ¼ inch thick plate on the top of the vehicle. The camera, the router, and the GPS antennae are mounted on this deck. There is also ample space to mount other sensors for experimental purposes. The Sensor Deck is mounted with two screws, at opposite corners; this allows easy access to the electronics deck beneath.



Figure 26. Sensor Deck onboard AUDASS II

I. SUPPORT EQUIPMENT

1. Air/Nitrogen Supply

The vehicle's propulsion/floatation tank is replenished by using a fill whip attached a 6000 psi nitrogen/air tank; known as a "K" type bottle. The vehicle's propulsion/floatation system is compatible with both air and nitrogen. The vehicle's tank is capable of a maximum service pressure of 310 bar (4500 psi), while the bottle is capable of 413 bar (6000 psi). Therefore, the fill whip is equipped with a relief valve set to discharge at 310 bar (4500 psi), to avoid over pressurizing the vehicle's tank. Procedures for refilling the vehicle's propulsion/floatation tank are provided in Appendix C.

2. Battery Recharging

The vehicle's power supply is recharged by bringing the vehicle to the battery recharging station and plugging the recharging cables into the batteries. A total recharge takes approximately two hours. An alternative is to replace the batteries with a recharged pair. Additionally, it is possible to operate the vehicle with just one battery, however, this reduces the vehicle's power endurance. Recharging procedures are included in Appendix C.

THIS PAGE INTENTIONALLY LEFT BLANK

III. PERFORMANCE

A. CONTROLLER PERFORMANCE

The AUDASS II vehicle was successful at its goal of autonomously rendezvousing and docking with the stationary target vehicle. In the final demonstration, the chaser (AUDASS II) started two meters from the target and 25 centimeters off centerline, then, AUDASS II successfully docked with the target (AUDASS I). During this demonstration, the AUDASS II controller navigated to a series of intermediate set points that led to a proper docking position. Below is a diagram describing the path that AUDASS II was commanded to follow.

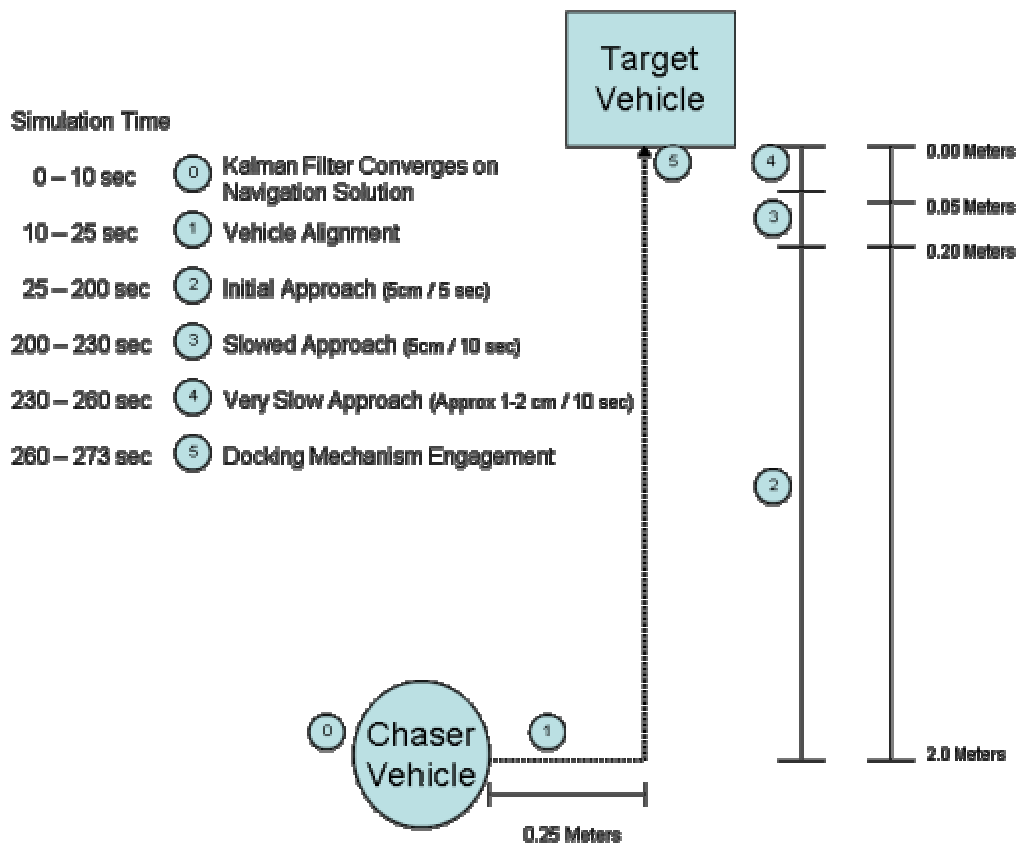

Figure 27. Rendezvous and docking demonstration commanded track

The figure below shows the vehicle's response. Note that the vehicle first lines up with the target and then begins to close. The y axis shows the distance from the target in meters (yTG), while the x axis shows lateral distance off the commanded track (xTG) in meters.

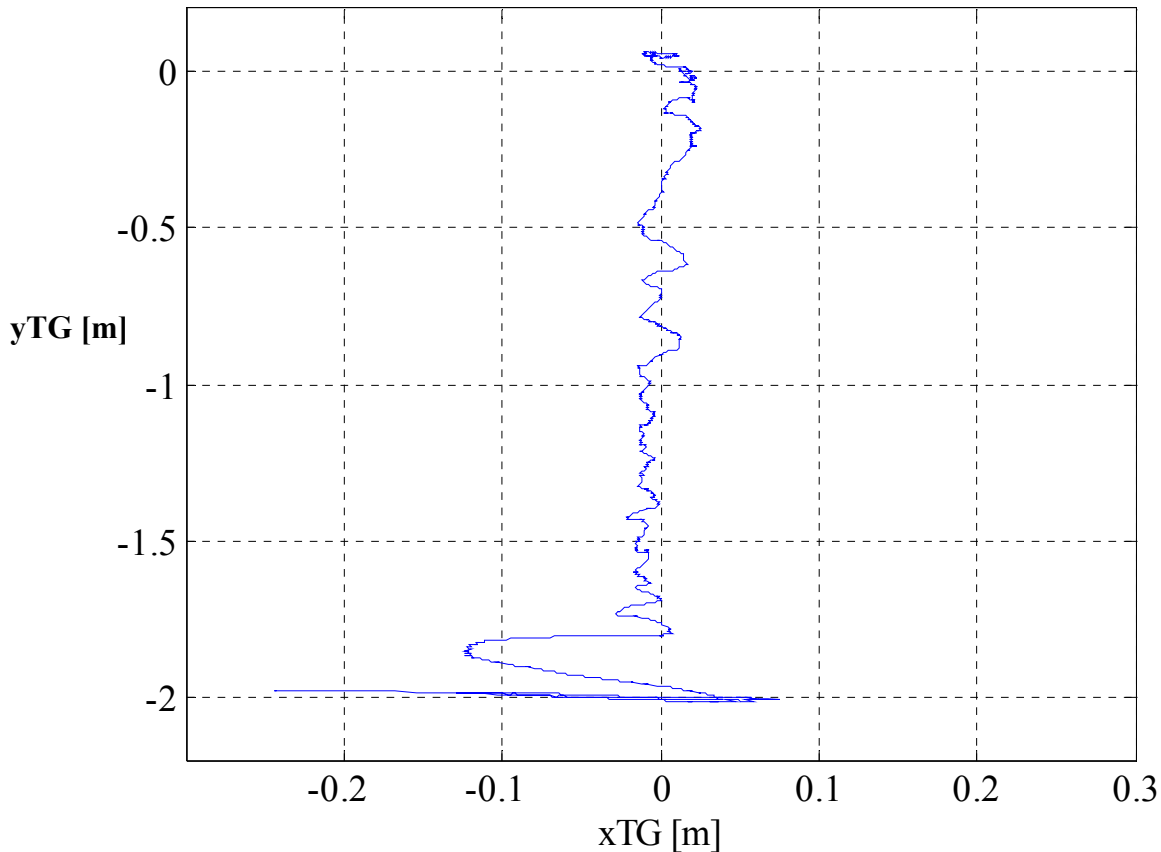

Figure 28. Chaser vehicle response during rendezvous and docking demonstration

Other demonstrations were conducted. During one of these demonstrations, the AUDASS II, starting from 2 meters off target, on axis, was able to navigate a complete circle, maintaining a constant attitude. During this maneuver, there were periods in which the target was out of sight of the chaser, the chaser successfully used its Kalman filter to determine position and maintain attitude. Specifics regarding vehicle control during these test may be found in Captain David Friedmans's thesis [Ref (4)].

B. PROPELLANT EFFICIENCY

Initial testing involved control via thrusters only. During this mode of operation the vehicle consumed approximately 400-500 psi per minute. With the integration of the

reaction wheel for control about the vertical axis, consumption was reduced to approximately 200-300 psi per minute. At this rate, the vehicle could be expected to operate for 15 minutes continuously, if it were given a full charge on the high-pressure tank (310 bar/4500 psi). Consumption rate varies according to what the task the vehicle is performing. During simple station keeping the vehicle uses significantly less gas than performing translation. It is estimated that the vehicle could station keep for approximately 25 minutes if given a full charge.

The vehicle is able to effectively operate with pressures down to 200 psi. When the supply tank falls below this pressure the regulators have difficulty providing continuous pressure during high thrust demand. This problem can be resolved if the cross feed valve is opened and the regulators operate in parallel.

Using a different, more efficient, control algorithm can enhance propulsion optimization. For example, during initial testing, in order to limit closing velocity and subsequent overshoot (i.e. collision with the target) the controller used a system of navigating to various intermediate set points in order to progress toward the target. One disadvantage with this method is that it required the vehicle to decelerate as it approached these intermediate points. This periodic acceleration and deceleration are detrimental to vehicle endurance. A solution is to either reduce the number of intermediate set points or use a speed limiter in order to control the closing velocity.

C. POWER EFFICIENCY

With the addition of the reaction wheel for control about the vertical axis, the vehicle uses significantly more power from the batteries. However, it is reasonable to expect the vehicle to operate for at least four hours if the batteries are fully charged.

D. RELIABILITY AND TROUBLESHOOTING

The vehicle has proven to be very reliable. However, there have been some minor problems. The following is a list of the most common problems and their solution.

1. Electrical Shorts

On occasion electrical shorts have occurred. These are usually caused by a failure in a solder point within the connection housing between two wires. If there is a short, an audible buzzing sound will be heard emanating from the DC-DC converter. To help isolate the short, disconnect all components (i.e. Floatation Solenoid, Thruster Solenoid,

RWS, and MDS), then, reconnect them individually until the sound from the DC-DC converter returns. The component that caused the sound to return indicates the source of the short. At this point it may be necessary to disassemble the electrical connection housing to locate the short.

2. Stuck Solenoids

Occasionally, thruster solenoids will stick in the open position. If this occurs close the main valve from the supply tank in order to prevent excessive loss of air. The remedy to this problem is to use a jumper to short the relay that activates the affected solenoid. This will usually resolve the problem, if it does not, solenoid replacement may be necessary.

IV. CONCLUSION

A. SUMMARY

Starting from a set of initial requirements, the vehicle was conceptualized as a follow on to AUDASS I. Through component selection and configuration changes, AUDASS II has proven to be a superior vehicle. AUDASS II enjoys greater endurance and superior control due to the introduction of the reaction wheel. Additionally, due to the modular design, maintenance and servicing have become easier.

With the introduction of the Mechanical Docking System into the two vehicle testbed, the AUDASS II and AUDASS I vehicles provide an excellent platform from which to conduct future control and/or sensor experimentation. Hopefully, future students will be able to capitalize on these vehicles.

B. FUTURE WORK

The next step in design will involve the fabrication of a deck for fluid supply. This will be required in order to conduct the ultimate purpose of the testbed, fluid transfer. Due to the modular nature of the vehicle the introduction of this new deck should be simple. However, there are design issues that must be overcome. One technical problem to be overcome will be sloshing mitigation. As the vehicle maneuvers, the fluid within the fluid reservoir will have a tendency to slosh; this will make adequate control of the vehicle nearly impossible, especially in proximity to the target during the docking phase. This sloshing may be overcome by purchasing, or fabricating, a baffled tank, or placing some material within the reservoir to mitigate the sloshing (synthetic porous foam).

Upon successful fluid transfer, the next logical evolution would be to operate the target as a free-floating object. This will involve solving a couple of technical problems. First, while it may not be visible, there is a slope in the floor, if one were to run a demonstration in which the target vehicle is floating during the entire demonstration, the target would drift away from the chaser in an unrealistic way. Therefore, it will be necessary to activate floatation when the chaser is near the target at the docking phase of the demonstration. Additionally, as the chaser approaches the target, the thrusters will

tend to plume the target, thus, imparting a force and subsequent acceleration on the target. Therefore, it will be necessary to configure the chaser's thrusters in a way to avoid pluming the target. To solve this problem, it is recommended to cant the forward thrusters (#1 and #2) outward at approximately 45 degrees. Further, the controller will have to be modified in order to compensate for the new thruster configuration. Once coupled with the target, the chaser vehicle will now be responsible for the control of both vehicles. This will be a complicated control problem for a number of reasons. First, the moment of inertia will dramatically change. Also, the center of rotation for the system will no longer be the vertical axis of the chaser vehicle, and a subsequent "lever" effect will have to be accounted for. Additionally, if there is fluid transfer taking place, the moment of inertia, the axis of rotation and center of mass will all be changing with time. This will all have to be accomplished while compensating for a slope induced drift.

Another possible project would be to test various control algorithms and sensors. This could include optimization experiments. The possibilities of the vehicle's use are broad and it is hoped that the testbed is used for this purpose in the future.

APPENDIX A

A. PARTS INFORMATION AND LIMITATIONS:

Propulsion System:

High Pressure side Propulsion System assembly was done by SCBA Safety Check, Fremont CA.

Tel: (888) 723-3722

Maximum pressure: 8.6 bar (125 psi), limited by solenoid.

Tank:

Manufacturer: Luxfer, Luxfer model # L 87G

Purchased from Survivair, model # 917160.

Maximum pressure: 310 bar (4500 psi)

High-pressure hose:

1/8 inch inner diameter,

Maximum pressure: 413.7 bar (6000 psi)

Variable regulators:

Manufacturer: Aqua Environment, model # 415-4000

Pressure range: 0-27 bar (0-400 psi)

Low-pressure tubing:

¼ inch ID, ½ inch OD, braided vinyl hose.

Maximum pressure: 25 bar (370 psi)

Solenoids:

Manufacturer: Asco, model # U 8225B002V

24 VDC, Normally Closed, rated for fluid and gas

Maximum pressure: 8.7 bar (125 psi)

Nozzles:

Manufacturer: Silvent, model MJ5

Floatation System:

Air Bearings:

Manufacturer: Aerodyne Belgium, model # PD-RA080

Maximum loading: 820 N @ 4 bar (ensures a 10 micron gap)

Tubing: Polyurethane 1/16 inch ID x 1/8 inch OD

Reaction Wheel System:

Reaction Wheel:

Manufacturer: Ball Aerospace,

Maximum Torque: .162 Nm @ 2500 rpm
Maximum speed: 3500 rpm, operation above 2500 rpm not recommended.
Power requirement: 18 volts DC +/- 2 volts

Mechanical Docking Mechanism

Active Interface:

Manufacturer: Starsys Research, Boulder Colorado.

Tel: (303) 530-1925

Model: Prototype

Maximum pressure for fluid transfer coupler: 5 bar

Maximum capture yaw angle: +/- 5-10 degrees

Power Distribution System:

Batteries:

Manufacturer: UltraLife,

Model #: UBL 2590

DC-DC Converter:

Manufacturer: Vicor,

Model #: "Vipac" Array, custom design

Input voltage: 24 Volts

Maximum power output per converter: 100 Watts

Relay Arrays:

Manufacturer: RTD Embedded Technologies

Tel: (814) 234-8087

Model #: MR 16

APPENDIX B

A. WARNINGS, CAUTIONS, AND NOTES:

Warning: Do not operate the reaction wheel above 3500 rpm, this may lead to destruction of the reaction wheel and/or vehicle, and may cause injury or death.

Warning: The exit orifice of the gas nozzles associated with the thrusters should not be touched during operation. Impregnation of the skin, by the escaping high velocity gas, is possible under these circumstances.

Warning: The vehicle's air tank is recharged via a fill whip. This fill Whip has an integrated relief valve. The Prescribed supply bottle is capable of 6000 psi, while the vehicle air tank is only capable of 4500 psi. Accordingly, the relief valve in the fill whip is set to discharge when 4500 psi is reached. If this relief valve fails, it is possible to over pressurize the vehicle air tank. This could result in the structural failure of the tank, causing severe damage to the vehicle and possibly injury or death to bystanders.

Caution: The Air Bearings are exceptionally sensitive to contamination, and there is no practical way to clean them. Consequently, care should be taken to limit their exposure to contaminants. If the vehicle is lifted and placed on a surface other than the epoxy floor, some form of impermeable cover should be placed over the bearings (cling wrap or a plastic garbage bag, for instance). Additionally, the epoxy floor itself should not be cleaned with any solvents or chemical cleaners. These products leave a residue that can permanently destroy the bearings. This has actually occurred in the lab, so believe it.

Caution: The Vehicle should only be picked up by the bottom most base plate. Picking the vehicle up in any other way may result in structural failure at interface between modules.

Caution: Do not run the Active Interface of the Mechanical Docking System to full deployment or full engagement. This will damage the drive mechanism.

Caution: The Active Interface of the Mechanical Docking System has an integrated limit switch to prevent prolonged activation of the engagement circuit causing the piston to "bottom out". However, this limit switch only prevents over engagement via computer initiation. It is possible to over engage by manually pressing the engagement switch on the control box, the limit switch will not prevent this.

Caution: Constant acceleration of the reaction wheel from zero rpm to 2500 rpm requires approximately 110 seconds. Care should be taken to not allow the reaction wheel to "spin up" for a time longer than this. Otherwise overspeed may occur, causing damage.

Note: Through experimentation, it has been determined that the MDS control box housing must be electrically isolated from the vehicle structure in order to operate properly.

Note: The Ultra-Life 2590 Li Ion batteries are equipped with an integrated circuit that controls output. One aspect of this control is a current limiter. The battery will short out if at any moment, the output current reaches 10 amps (Indicated by a blank power level indicator). This level of output is possible when charging capacitors, particularly during computer start up. This problem was avoided on AUDASS II by using computer power supplies that self limited their initial draw upon startup. If other power supplies are used, that do not have this feature, the batteries may short out upon computer start up. To reset the batteries, simply place the recharging cord into the battery for 1 second then remove.

Note: The vehicle's air system is not completely airtight. Therefore, even when not operating the system will slowly lose air. Consequently, the vehicle tank valve should be closed when not in use. Otherwise, over a long period of time (days), the vehicle's air supply will be depleted.

APPENDIX C

A. PROCEDURES

1. Refilling the High Pressure Gas Cylinder:

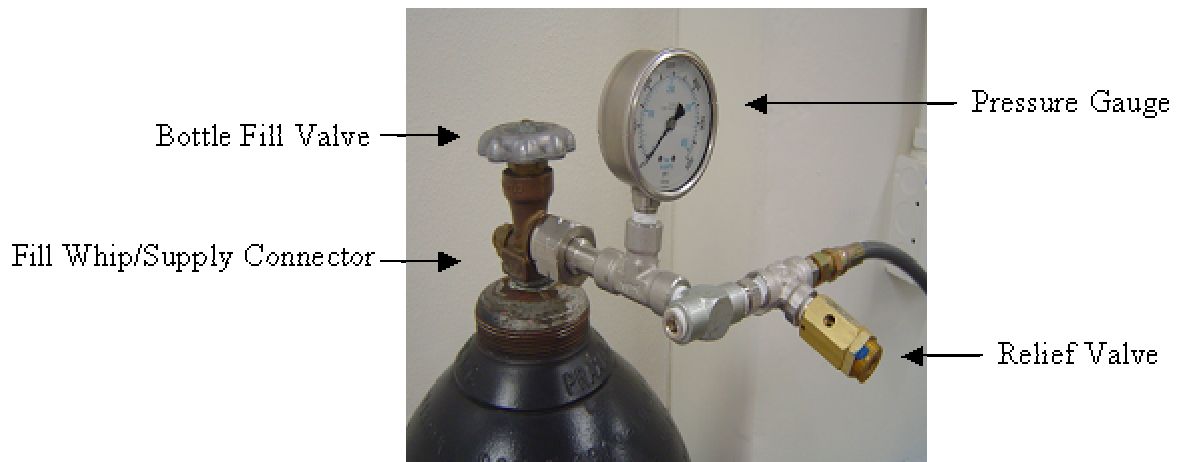

1. Ensure fill whip is tightly connected to supply bottle (Fill Whip/Supply Bottle connector has a left hand thread. Wrench necessary).

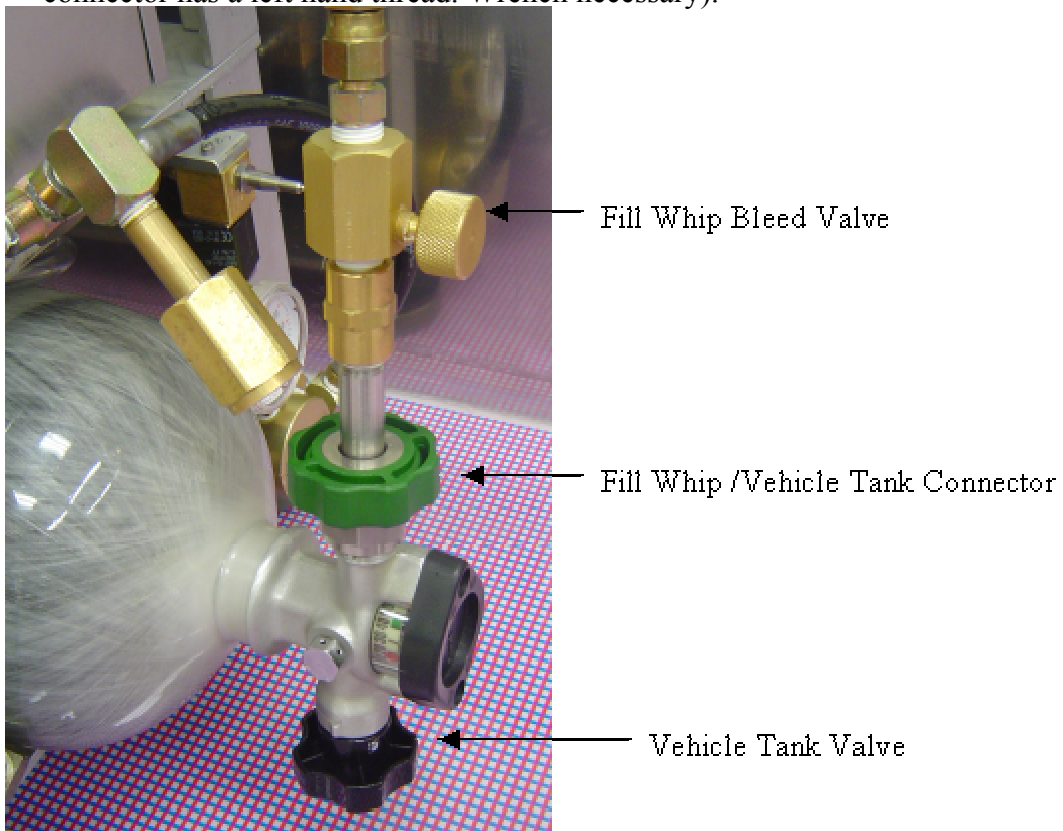

2. Ensure fill whip is properly attached to vehicle tank (turn green handle, at the end of fill whip, clockwise until tight. Wrench not necessary)
- c. Ensure fill whip bleed valve is closed (full clockwise).
- d. Fully open vehicle tank valve (turn counter clockwise).
- e. Slowly open the fill valve on the supply bottle (turn counterclockwise). Allow only slow pressure increase in the vehicle tank (approximately 500 psi per minute, in order to reduce thermal shock) Bear in mind that the fill whip is equipped with a 4500 psi relief valve, however, if this relief valve fails, it is possible to over pressurize the vehicle tank. Constant attention is recommended.
- f. When the desired pressure is reached, close the supply bottle fill valve (turn clockwise).
- g. Close the vehicle tank valve (turn clockwise)
- h. Slowly open the bleed valve on the fill whip (turn counter clockwise)
- i. When the fill whip is depressurized (gauge on supply bottle to 0), remove the fill whip from the vehicle tank.
- j. Attach vehicle air system to vehicle supply tank. (Must be wrench tight)

2. Recharging Batteries:

1. Bring vehicle to charging station.
2. Remove vehicle power cables from battery terminals
3. Plug charging cables into batteries. (ensure chargers are plugged in). Green lights on charging stand should start blinking to indicate charging.
4. When power indicators on the front of the batteries show full charge, disconnect charging cables and reconnect vehicle's power cables.

3. Running Demonstrations:

Before starting, ensure vehicle power cables are inserted into the battery terminals, the demonstration control computer is turned on, the vehicle is placed in an

appropriate position relative to the target vehicle (this position is dependent on the specific demonstration being performed), and ensure that the target LEDs are on (1.2 VDC input required).

1. Turn vehicle power switch to ON position (computers, camera, and router should turn on)
2. At demonstration control computer: Connect to onboard vision computer:
 - a. Click on “Tight VNC Viewer” desktop icon.
 - b. When the window containing the IP address 192,168,0.104 appears click “ok”.
 - c. When prompted for password, type “pippo”.
 - d. A Windows login window will appear. The user name is “Administrator”, there is no password, so leave the password field blank. Click “ok”.
 - e. A directory will appear, within the directory click “MALAB 7.0”. (If this directory does not appear, click on the Matlab icon)
 - f. When the Matlab command prompt appears type “run_cycle”. This initiates camera imaging.
 - e. Minimize the MATLAB window.
3. At demonstration control computer: Convert control algorithm to C, compile and send to onboard control computer:
 - a. Create a new, or use a preexisting, control algorithm in Simulink.
 - b. Run associated “.m” data files.
 - c. Verify that the program is in “External” mode, as opposed to “Normal” mode.
 - d. Convert into C by clicking “Incremental Build” icon on toolbar.
4. At the vehicle:
 - a. Ensure the float and propulsion regulators are set to appropriate pressures
 - b. Ensure docking mechanism is turned on and rheostat set to full counter-clockwise position.

5. At the demonstration control computer:
 - a. To start demonstration type “tg.start” in the Matlab command window. (Kalman filter will converge on a solution for the first 10 seconds, then the vehicle will start to operate).
 - f. To stop a demonstration, type “tg.stop” in the Matlab command window (if the demonstration does not have a built in stop command).
 - g. To shut down the system, close all applications as you would any Windows application.
6. At the vehicle: Shut Down
 - a. After the demonstration is complete, open the float bypass solenoid to float the vehicle, press “Deploy” on the Mechanical Docking System control box. This will separate the vehicles. Close float bypass valve.
 - b. Turn of Mechanical Docking System, turn rheostat knob to off (clockwise).
 - c. After the demonstration control computer has closed the vision and control applications, turn vehicle power switch to the OFF position.

APPENDIX D

MASS PROPERTIES

| Part | Mass (kg) | Size X (m) | Size Y (m) | Diameter | CMx (m) | CMy (m) | CMz (m) | Izz comp (kg m ²) | Izz ref (kg m ²) | Izz (kg m ²) |
|------------------|-----------|------------|------------|----------|---------|---------|---------|-------------------------------|------------------------------|--------------------------|
| Bearing 1 | 0.68 | | | 0.08 | 0.19 | -0.19 | 0.2687 | 0.000544 | 0.049096 | 0.04964 |
| Bearing 2 | 0.68 | | | 0.08 | 0.19 | 0.19 | 0.2687 | 0.000544 | 0.049096 | 0.04964 |
| Bearing 3 | 0.68 | | | 0.08 | -0.19 | 0.19 | 0.2687 | 0.000544 | 0.049096 | 0.04964 |
| Bearing 4 | 0.68 | | | 0.08 | -0.19 | -0.19 | 0.2687 | 0.000544 | 0.049096 | 0.04964 |
| Vert Support 1 | 0.96 | 0.04 | 0.04 | | 0.19 | -0.19 | 0.2687 | 0.000256 | 0.069312 | 0.069568 |
| Vert Support 2 | 0.96 | 0.04 | 0.04 | | 0.19 | 0.19 | 0.2687 | 0.000256 | 0.069312 | 0.069568 |
| Vert Support 3 | 0.96 | 0.04 | 0.04 | | -0.19 | 0.19 | 0.2687 | 0.000256 | 0.069312 | 0.069568 |
| Vert Support 4 | 0.96 | 0.04 | 0.04 | | -0.19 | -0.19 | 0.2687 | 0.000256 | 0.069312 | 0.069568 |
| X brace 1 (x4) | 0.68 | 0.39 | 0.006 | | 0.2 | 0 | 0.2 | 0.00862104 | 0.0272 | 0.03582104 |
| X brace 2 (x4) | 0.68 | 0.39 | 0.006 | | 0 | 0.2 | 0.2 | 0.00862104 | 0.0272 | 0.03582104 |
| X brace 3 (x4) | 0.68 | 0.39 | 0.006 | | -0.2 | 0 | 0.2 | 0.00862104 | 0.0272 | 0.03582104 |
| X brace 4 (x4) | 0.68 | 0.39 | 0.006 | | 0 | -0.2 | 0.2 | 0.00862104 | 0.0272 | 0.03582104 |
| Deck 1 | 2.7 | 0.4 | 0.4 | | 0 | 0 | 0 | 0.072 | 0 | 0.072 |
| Deck 2 | 2.7 | 0.4 | 0.4 | | 0 | 0 | 0 | 0.072 | 0 | 0.072 |
| Deck 3 | 2.7 | 0.4 | 0.4 | | 0 | 0 | 0 | 0.072 | 0 | 0.072 |
| Deck 4 | 2.7 | 0.4 | 0.4 | | 0 | 0 | 0 | 0.072 | 0 | 0.072 |
| Deck 5 | 2.7 | 0.4 | 0.4 | | 0 | 0 | 0 | 0.072 | 0 | 0.072 |
| Tank (full) | 8.6 | 0.55 | | 0.18 | 0.05 | 0 | 0.05 | 0.251621667 | 0.0215 | 0.27312167 |
| Float Reg | 1.5 | 0.14 | | 0.06 | -0.17 | 0.15 | 0.2267 | 0.003125 | 0.0771 | 0.080225 |
| Propulsion Reg | 1.5 | 0.14 | | 0.06 | -0.17 | -0.15 | 0.2267 | 0.003125 | 0.0771 | 0.080225 |
| Air Flask | 1.95 | 0.25 | | 0.06 | 0.08 | 0.13 | 0.1526 | 0.01103375 | 0.045435 | 0.05646875 |
| Float Bypass | 0.5 | 0.15 | | 0.01 | 0.08 | 0.13 | 0.1526 | 0.00094375 | 0.01165 | 0.01259375 |
| Thruster 1 | 0.18 | 0.02 | 0.023 | | 0.22 | -0.15 | 0.2663 | 0.000013935 | 0.012762 | 0.01277594 |
| Thruster 2 | 0.18 | 0.02 | 0.023 | | 0.22 | 0.15 | 0.2663 | 0.000013935 | 0.012762 | 0.01277594 |
| Thruster 3 | 0.18 | 0.02 | 0.023 | | 0.15 | 0.22 | 0.2663 | 0.000013935 | 0.012762 | 0.01277594 |
| Thruster 4 | 0.18 | 0.02 | 0.023 | | -0.15 | 0.22 | 0.2663 | 0.000013935 | 0.012762 | 0.01277594 |
| Thruster 5 | 0.18 | 0.02 | 0.023 | | -0.22 | 0.15 | 0.2663 | 0.000013935 | 0.012762 | 0.01277594 |
| Thruster 6 | 0.18 | 0.02 | 0.023 | | -0.22 | -0.15 | 0.2663 | 0.000013935 | 0.012762 | 0.01277594 |
| Thruster 7 | 0.18 | 0.02 | 0.023 | | -0.15 | -0.22 | 0.2663 | 0.000013935 | 0.012762 | 0.01277594 |
| Thruster 8 | 0.18 | 0.02 | 0.023 | | 0.15 | -0.22 | 0.2663 | 0.000013935 | 0.012762 | 0.01277594 |
| Active Interface | 8.2 | 0.23 | | 0.13 | 0.16 | 0 | 0.16 | 0.053470833 | 0.20992 | 0.26339083 |
| MDS Control Box | 1 | 0.15 | 0.25 | | -0.13 | 0 | 0.13 | 0.007083333 | 0.0169 | 0.02398333 |
| RW Housing | 2.3 | | | 0.29 | 0 | 0 | 0 | 0.02417875 | 0 | 0.02417875 |
| Voltage Clamp | 0.2 | 0.05 | 0.03 | | -0.12 | 0.12 | 0.1697 | 5.66667E-05 | 0.00576 | 0.00581667 |
| Battery 1 | 1.4 | 0.12 | 0.06 | | 0.12 | -0.03 | 0.1237 | 0.0021 | 0.02142 | 0.02352 |
| Battery 2 | 1.4 | 0.12 | 0.06 | | 0.12 | 0.03 | 0.1237 | 0.0021 | 0.02142 | 0.02352 |
| DC-DC Converter | 0.6 | 0.18 | 0.09 | | 0.11 | 0.16 | 0.1942 | 0.002025 | 0.02262 | 0.024645 |
| Relay Stack | 0.6 | 0.07 | 0.15 | | -0.17 | 0.13 | 0.214 | 0.00137 | 0.02748 | 0.02885 |
| Control Computer | 0.5 | 0.09 | 0.09 | | -0.15 | -0.15 | 0.2121 | 0.000675 | 0.0225 | 0.023175 |
| Vision Computer | 0.5 | 0.09 | 0.09 | | 0.15 | -0.17 | 0.2267 | 0.000675 | 0.0257 | 0.026375 |
| IMU | 1.2 | 0.075 | 0.075 | | 0 | 0 | 0 | 0.001125 | 0 | 0.001125 |
| | 56.17 | | | | | | | | | |
| Reaction Wheel | 6.9 | | | | | | | | | |
| | 63.07 | | | | | | | | | |
| | | | | | | | | | Total Izz | 2.05353739 |

Simple Estimate for rectangular prism ($I_{zz} = 1/12 * m * (a^2 + b^2)$)

Simple Estimate for symmetric dumbbell ($I_{zz} = m * r^2$)

[Ref (6)]

Table 3. Mass Properties

THIS PAGE INTENTIONALLY LEFT BLANK

LIST OF REFERENCES

1. Yoshida, K. 1994. *Practical coordination control between satellite attitude and manipulator reaction dynamics based on computed momentum concept*. In Proceedings of the IEEE/RSJ International Conference on Intelligent Robots and Systems, Munich, Germany, pp. 1578-1585.
2. Porter, M., *Development and Control of the Naval Postgraduate School Planar Autonomous Docking Simulator (NPADS)*, MS Thesis, Naval Postgraduate School, 2002.
3. Ball Aerospace, *20.3 N-m-s reaction Wheel User Manual*, March 2000.
4. Friedman, David, *Laboratory Experimentation of Autonomous Spacecraft Docking Using Cooperative Vision Navigation*, MS Thesis, Naval Postgraduate School, December 2005.
5. Vicor Corporation, *Vipac Array Configuration Guide, Rev. 1.5*, October 2004.
6. Baruh, H., *Analytical Dynamics*, pp 337-345, WCB/McGraw Hill, 1999.
7. Ulman, M, *Experiments in Autonomous Navigation and Control of Multi-Manipulator, Free-Flying Space Robots*, Ph.D. Dissertation, Stanford University, March 1993.

THIS PAGE INTENTIONALLY LEFT BLANK

INITIAL DISTRIBUTION LIST

1. Defense Technical Information Center
Ft. Belvoir, Virginia
2. Dudley Knox Library
Naval Postgraduate School
Monterey, California
3. Professor Marcello Romano
Naval Postgraduate School
Monterey, California