

Scintillator-based Low-Energy Imaging Particle Spectrometer

**G.E. Galica
R.L. Coxe
R.G. Chaves
H.E. Spence
B.K. Dichter
D.L. Cooke
G. Ginet**

G.E. Galica, R.L. Coxe, R.G. Chaves, H.E. Spence, B.K. Dichter, D.L. Cooke, G. Ginet, "Scintillator-based Low-Energy Imaging Particle Spectrometer," presented at JAXA 9th Spacecraft Charging Technology Conference (Tsukuba, Japan), (4-8 April2005).

Copyright © 2005 Physical Sciences Inc.

All rights reserved

Downloaded from the [Physical Sciences Inc. Library](http://www.psicorp.com/publications/sr-1223.shtml). Abstract available at <http://www.psicorp.com/publications/sr-1223.shtml>

Report Documentation Page

Form Approved
OMB No. 0704-0188

Public reporting burden for the collection of information is estimated to average 1 hour per response, including the time for reviewing instructions, searching existing data sources, gathering and maintaining the data needed, and completing and reviewing the collection of information. Send comments regarding this burden estimate or any other aspect of this collection of information, including suggestions for reducing this burden, to Washington Headquarters Services, Directorate for Information Operations and Reports, 1215 Jefferson Davis Highway, Suite 1204, Arlington VA 22202-4302. Respondents should be aware that notwithstanding any other provision of law, no person shall be subject to a penalty for failing to comply with a collection of information if it does not display a currently valid OMB control number.

1. REPORT DATE 2005		2. REPORT TYPE		3. DATES COVERED 00-00-2005 to 00-00-2005	
4. TITLE AND SUBTITLE Scintillator-Based Low-Energy Imaging Particle Spectrometer				5a. CONTRACT NUMBER	
				5b. GRANT NUMBER	
				5c. PROGRAM ELEMENT NUMBER	
6. AUTHOR(S)				5d. PROJECT NUMBER	
				5e. TASK NUMBER	
				5f. WORK UNIT NUMBER	
7. PERFORMING ORGANIZATION NAME(S) AND ADDRESS(ES) Physical Sciences Inc,20 New England Business Center,Andover,MA,01810				8. PERFORMING ORGANIZATION REPORT NUMBER	
9. SPONSORING/MONITORING AGENCY NAME(S) AND ADDRESS(ES)				10. SPONSOR/MONITOR'S ACRONYM(S)	
				11. SPONSOR/MONITOR'S REPORT NUMBER(S)	
12. DISTRIBUTION/AVAILABILITY STATEMENT Approved for public release; distribution unlimited					
13. SUPPLEMENTARY NOTES The original document contains color images.					
14. ABSTRACT see report					
15. SUBJECT TERMS					
16. SECURITY CLASSIFICATION OF:			17. LIMITATION OF ABSTRACT	18. NUMBER OF PAGES 7	19a. NAME OF RESPONSIBLE PERSON
a. REPORT unclassified	b. ABSTRACT unclassified	c. THIS PAGE unclassified			

SCINTILLATOR-BASED LOW-ENERGY IMAGING PARTICLE SPECTROMETER

G. E. Galica, R. L. Coxe, R. G. Chaves
Physical Sciences Inc., 20 New England Business Center, Andover, MA 01810
Tel: 978-689-0003; Fax: 978-689-3232; e-mail: galica@psicorp.com

H. E. Spence
Boston University Center for Space Physics,
725 Commonwealth Avenue, Boston, MA 02215
Tel: 617-353-7412; Fax: 617-353-6463; e-mail: spence@bu.edu

B. K. Dichter, D. L. Cooke, and G. Ginot
Air Force Research Laboratory, Space Vehicles Directorate
Hanscom AFB, MA 01731
Tel: 781-377-3991; Fax: 781-377-3160; e-mail: bronek.dichter@hanscom.af.mil

Abstract

Physical Sciences Inc. (PSI), in cooperation with the Boston University Center for Space Physics, and under the sponsorship of the Air Force Research Laboratory Space Vehicle Directorate, has developed and tested a lightweight, multi-configuration sensor to monitor the space weather environment. The scintillator-based, Low-Energy Imaging Particle Spectrometer (LIPS) is ideally suited to monitoring the lower energy (20 to 2000 keV) charged particle environment responsible for deep dielectric charging. The LIPS design is also compatible with the weight, volume, and power requirements of small satellites (<1 kg, <2 W). The LIPS design does not rely upon a magnetic sector to discriminate between particle types; rather it takes advantage of particle cross-section characteristics and scintillator properties to discriminate. We have previously reported on the feasibility demonstration of our approach; i.e., using thin films of materials to create particle-specific detectors, coupled to a position-sensitive photomultiplier tube. We have since developed a fully-functional and calibrated engineering model of LIPS. We are currently preparing LIPS for flight validation as part of the Air Force Research Laboratory (AFRL) Space Weather Experiment (SWx) that will fly as part of the Cygnus flight demonstration program. Herein we report on the engineering model development and calibration of LIPS.

Background

The need to monitor space weather is essential because of the potential for satellite loss or service interruption during periods of high geomagnetic activity or severe radiation conditions. Space weather is the manifestation of the intimate connection between the earth and the sun. The space surrounding the earth is a highly dynamic environment that responds to changes in the sun. The sun is constantly bombarding the earth with high-energy particles and radiation. The dynamic interaction between this solar wind, the earth's magnetic field and the sun's magnetic field determines the space weather. Since the space environment responds dramatically and sensitively to changes in the electromagnetic fields, particles and magnetic fields arriving from the sun, it is important to have early warning of such events. This response occurs with time delays of hours to days,^{1,2,3} and is at the core of space weather.

Satellites in earth orbit interact continuously over many years with this highly dynamic space environment. Rapid changes in the space environment cause increased radiation damage, single event upsets, spacecraft charging and damage to materials. All of these effects degrade satellite performance. Most often satellite systems degrade gradually in time; however, there are striking examples of sudden, unpredicted spacecraft failures correlated with geomagnetic activity.⁴

LIPS, as part of a space weather monitoring satellite network, would provide a crucial early warning of enhanced geomagnetic activity. A warning of an impending geomagnetic event would allow satellite operators to take action to minimize damage or service interruptions caused by the accompanying increased radiation. To protect against damage and service outages, spacecraft operators might choose to shift transmission bandwidth to satellites in less disturbed regions of space. By taking simple mitigation steps, satellite operators and users can minimize the risk and cost of losing a satellite, suffering interruption in service, and extend the orbital life.

Because of broad ranging effects of space weather and society's increasing reliance on satellite systems, it is paramount to monitor the space environment that affects those systems. Two of the missions of primary importance for

monitoring the space weather environment are measuring the ring current and the in-situ environment surrounding operational satellites. The ring current is one of the major components of the earth's magnetosphere. It encircles the earth along the equator at distances of 2 to 7 earth radii and comprises charged particles in the 10 to 200 keV energy range.⁵ Particles trapped in the earth's magnetic field exhibit three distinct motions: spiraling about field lines, bouncing between mirror points, and drifting longitudinally (electrons to the east, protons to the west). This longitudinal drifting creates the ring current. A sensor monitoring the ring current can provide several hours warning of an imminent geomagnetic disturbance thereby allowing satellite operators to react accordingly. To understand the ring current dynamics, one must measure the particle-energy distributions as well as the pitch angle distributions.

The ring current responds very quickly to geomagnetic activity by several mechanisms. During periods when the interplanetary magnetic field turns southward, particles are convectively transported from the nightside plasma sheet deep into the inner magnetosphere. Also during magnetospheric substorms, plasma is injected into the inner magnetosphere. This activity also energizes the ring current. The growth of the ring current occurs over several hours, but its decay can take several days. For example, during a particularly strong storm that occurred in February 1986, the ring current required more than 1 month to recover to its quiescent state.²

Sensor Configuration

We have built and calibrated an engineering model of a highly compact, lightweight, multi-configuration sensor to monitor the orbital charged particle environment. The Low-Energy, Imaging Particle Spectrometer (LIPS) is ideally suited to monitoring the lower energy (30 to 2000 keV) charged particle environment that contributes to the space weather and charging threat. We have previously presented the overall sensor concept.^{6,7}

Unlike many sensors designed for this energy region LIPS does not rely upon a magnetic sector to discriminate between particle types (protons versus electrons versus ions).^{8,9} Rather, the LIPS sensor design takes advantage of the cross-section characteristics of different particles, and the properties of scintillators to discriminate particle types. We have demonstrated that by using thin films of metals and plastic scintillators, we can create particle-specific detectors that serve as the core of a small charged-particle spectrometer. Figure 1 shows a schematic view of the basic sensor concept. The particle-specific detectors coupled to a high-gain, low-noise position-sensitive photomultiplier tube. By eliminating the magnetic sector and creating a more innovative design, we can produce a sensor that is extremely small and lightweight, and suitable for nanosatellite applications.

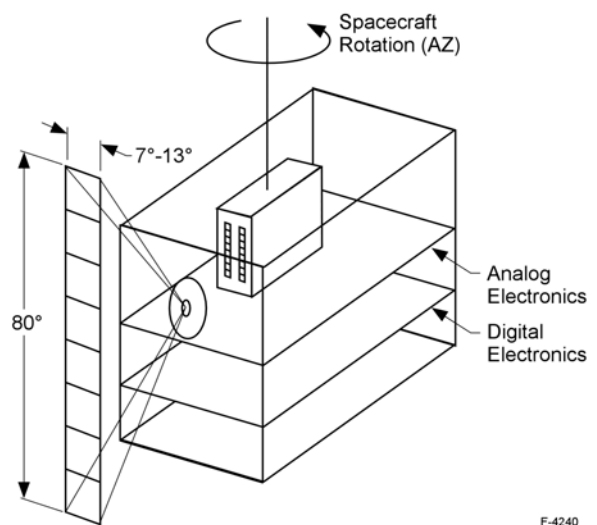

Figure 1. The Low Energy Particle Imaging Spectrometer sensor is configured as a pinhole camera-type, one-dimensional imager. Spacecraft rotation provides the second imaging axis. Particles enter the collimator aperture and are incident on particle-specific scintillator focal planes.

The LIPS sensor offers several advantages:

- Simple spectrometer design that eliminates magnetic and electric sectors
- Lightweight (<1 kg), low power (<2 W), small volume (90 x 90 x 176 mm³) sensor compatible with nanosatellite requirements
- Simple design built on inexpensive, readily available components resulting in a low cost sensor
- Sensor that meets the engineering requirements of a space weather threat sensor, with sufficient energy resolution to provide valuable data to improve the understanding of solar-terrestrial interactions
- Flexible design that is easily adaptable to different energy regimes and missions
- Small cross-contamination between protons and electrons.

Table 1 summarizes the LIPS baseline performance specification.

Table 1. LIPS Baseline Performance Specification

Parameter	LIPS specification
Particles	Protons Electrons
Energy range	30 to 2000 keV
Energy resolution	dE/E = 0.5 protons dE/E = 1.0 electrons
G-factor (IFOV)	$0.15 \text{ to } 1.3 \times 10^{-4} \text{ cm}^2 \text{ sr}$
Count rate	$\leq 2 \times 10^5 \text{ cps}$
Size	$90 \times 90 \times 176 \text{ mm}^3$
Weight	0.8 kg
Power	1.6 W

The LIPS is a pinhole camera-type, one-dimensional imager. The spacecraft rotation provides the second imaging dimension. (See Figure 1) Particles enter the collimator aperture and are incident on the scintillator focal plane. The focal plane comprises two or more distinct scintillators. We have demonstrated that by judiciously choosing the scintillator thickness and metallic coating, we can design scintillators that are sensitive only to electrons and only to protons (over an energy range of interest). This simple sensor design does not rely on a magnetic sector, and consequently has the advantages of small size and mass. The design takes advantage of the cross-section characteristics of different particles and the properties of scintillators to discriminate particle types. Figure 2 shows the exterior and interior components of the LIPS engineering model.

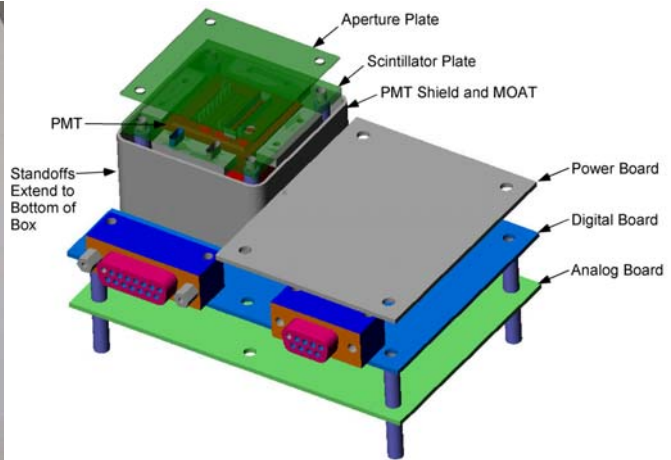
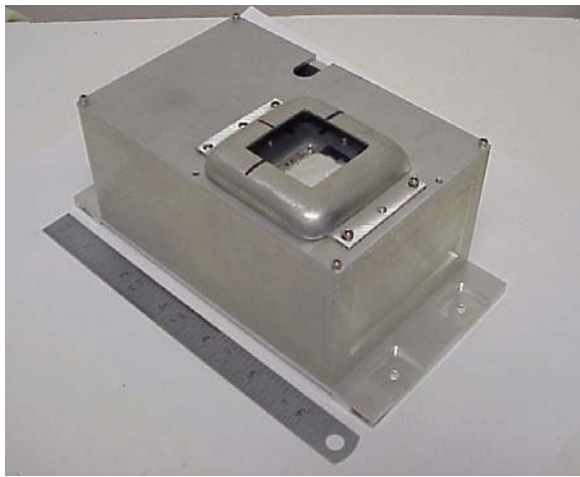

Figure 2. Exterior and interior of the LIPS Engineering Model.

Electronics Configuration

Figure 3 shows the overall block diagram of the LIPS electronics. The digital electronics are based on a ACTEL radiation-tolerant field programmable gate array (FPGA). The FPGA controls the MUX, peak-hold circuits, and ADC on the analog board, performs the energy analysis and event binning, and performs the telemetry interface functions.

The analog electronics are based on typical charge sensitive preamplifiers; however, simply using a separate preamplifier for each analog channel increased the cost and complexity of the system. Our alternative approach was to route the detector signals through an analog multiplexer before the preamplifier. A separate preamp for each channel provides the best performance. The analog multiplexer (MUX) approach, minimizes cost and board area, but potentially with the sacrifice of noise performance. However, our noise measurements revealed that the MUX approach would provide acceptable noise performance.

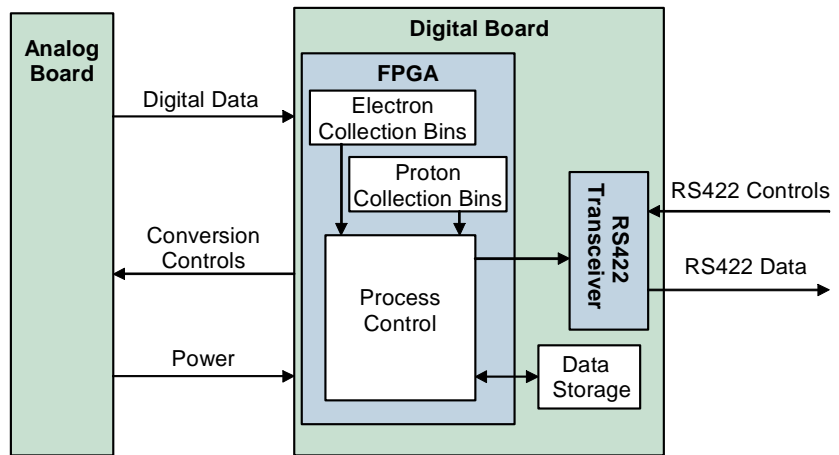

Figure 3. Overall electronics block diagram.

Figure 4 shows the histogram of signals obtained from the charge sensitive preamplifier (CSP) with a 2.2 pC test pulse as input. The noise is 0.75 fC (fwhm).

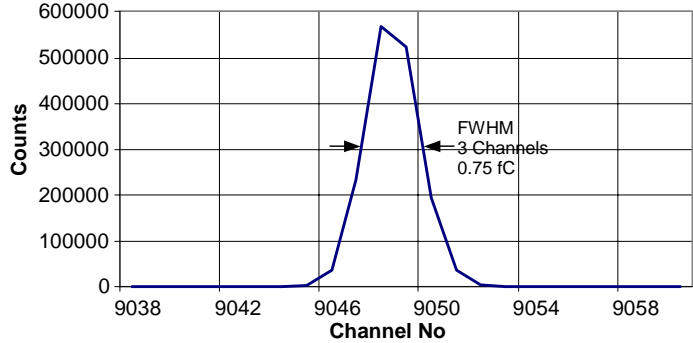
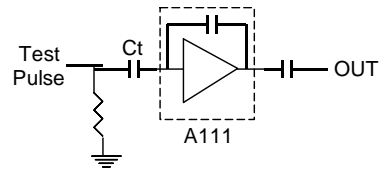

Figure 4. Histogram of signals from the CSP with a 2.2 pC test pulse.

Figure 5 shows the histogram of signals obtained from the analog electronics with a 44 fC test pulse input to the CSP through multiplexer. The noise has increased to 2.25 fC; however, the noise is still acceptable when compared to the minimum expected signal level of 30 fC.

Calibration

We have used two facilities for calibrating the LIPS sensor. We performed proton calibrations at University of North Texas (UNT), Department of Physics in Denton TX. The UNT facility has a van de Graaff generator that provide monoenergetic protons from 50 keV to 2500 keV. To reduce the flux, we use a forward-scattering configuration off Au foil at a scattering angle of 20 deg. UNT can particle rates of 50 Hz to 25 kHz at the sensor. We use an SSD with a 1 mm aperture (matched to LIPS) at the complementary scattering angle to monitor the proton flux.

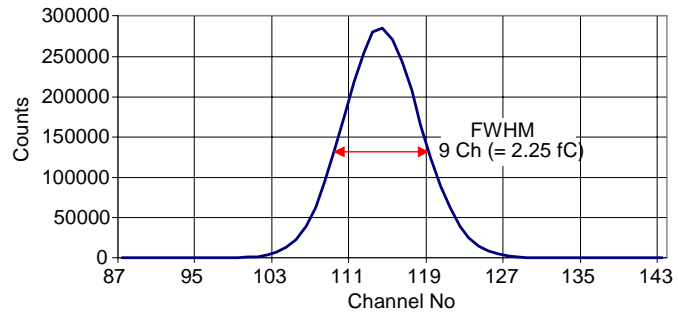
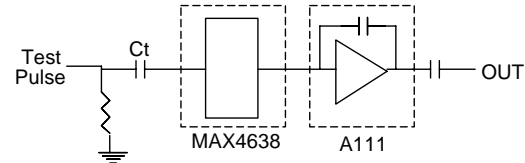

Figure 5. Histogram of signals from the analog electronics with a 44 fC test pulse input through a multiplexer.

We performed electron calibration at the Nation Institute of Standards and Technology (NIST) in Gaithersburg MD. NIST has a Cockroft Walton type accelerator that provides monoenergetic electronics in the 20 to 350 keV energy range. NIST also has a van de Graaff generator that provides monoenergetic electronics from 500 keV to 2000 keV. Those accelerators provide electron rates from 1 to 200 kHz. Table 2 summarizes the calibrations performed to date.

Figure 6 shows a histogram of analog signals from the electron scintillator under irradiation by 75 keV electrons. The 75 keV electrons are easily discernable and from these data we estimate a minimum detectable energy of 30 to 50 keV.

Figure 7 shows the linear energy response of the LPS sensor. The signal strength (volts) is plotted against the particle energy including both protons and electrons from different data sets (70 to 700 keV) along with a linear fit.

Cross-talk between pixels is minimal on both electron and proton channels. Figure 8 show the histograms of signals from an electron pixel irradiated with 200 keV electrons and its nearest neighbor. Cross-talk is negligible.

Energy resolution varies with particle type. Figure 9 shows energy resolutions for protons and electrons (500 keV protons and 250 keV electrons). In the laboratory, we also measured energy resolution with a Po-210 source. The resolution for the Po-210 source is $dE/E = 0.27$ (fwhm), for protons is $dE/E = 0.5$ (fwhm) and for electrons is

Table 2. Calibrations Performed To-Date

Facility	Particles	Energies
UNT	Protons	100 to 1200 keV
NIST	Electrons	50 to 250 keV 500 to 1000 keV
UNT	Protons	100 to 2000 keV
NIST	Electrons	75 to 350 keV

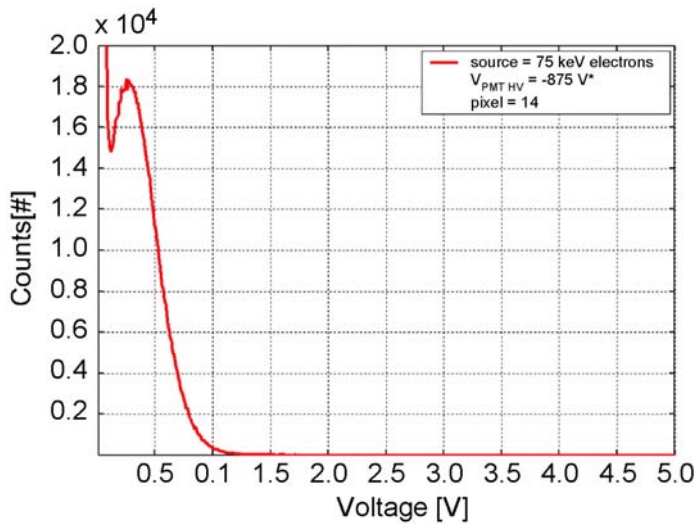

Figure 6. Histogram of analog signals from 75 keV electrons.

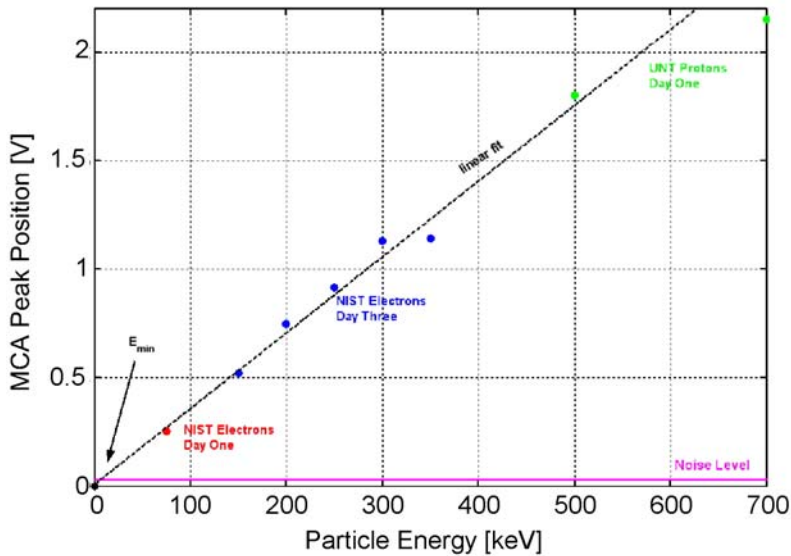

Figure 7. Linear energy response of LIPS to protons and electrons from 70 keV to 700 keV.

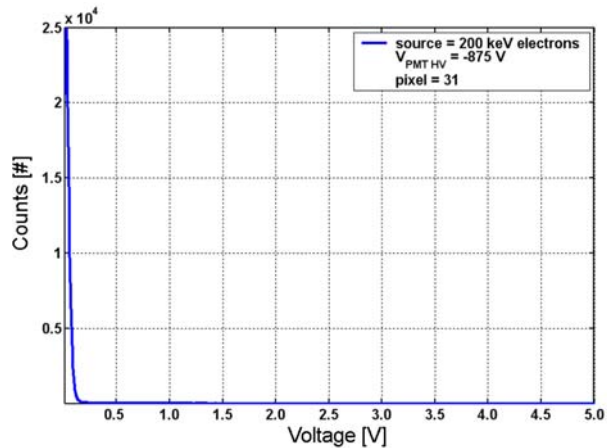
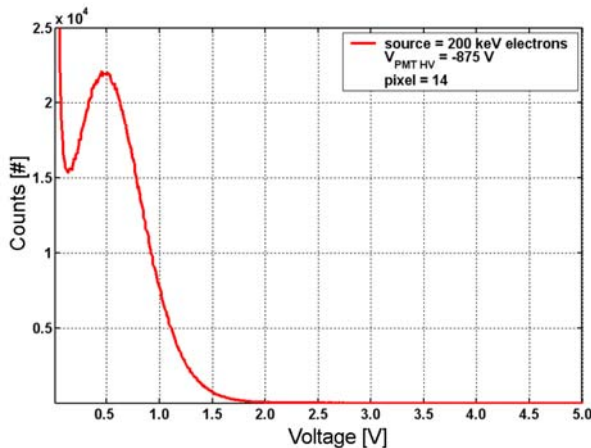

Figure 8. Histogram of signals from an electron pixel irradiated with 200 keV electrons (left and its nearest neighbor (right)).

$dE/E = 1.0$ (fwhm). Even with the poorer resolution of the electrons, the sensor will support six energy bins. The protons have better energy resolution and are more important for understanding the ring current relaxation.

Cross-particle contamination is also minimal. Figure 10 shows the response of the electron scintillator to irradiation with 2.2 MeV protons.

Summary

We have developed and tested a breadboard model of a novel, scintillator-based low energy particle imaging spectrometer. The LIPS design does not rely upon a magnetic sector to discriminate between particle types; rather it takes advantage of cross-section characteristics and scintillator properties to discriminate. The result is a tremendous savings in weight and volume. The sensor physical parameters are compatible with the requirements of nanosatellites. The LIPS is lightweight (0.8 kg), low power (1.6 W), and small volume ($90 \times 90 \times 176 \text{ mm}^3$).

We have proven the feasibility of our approach; i.e., using thin films of materials to create proton-specific and electron-specific detectors, fiber-optically coupled to a position-sensitive photomultiplier tube. Initial performance data indicate that the detectors have high specificity and reasonable energy resolution ($dE/E=0.5$ for protons, $dE/E=1$ for electrons) sufficient to support magnetospheric science and space weather early warning missions.

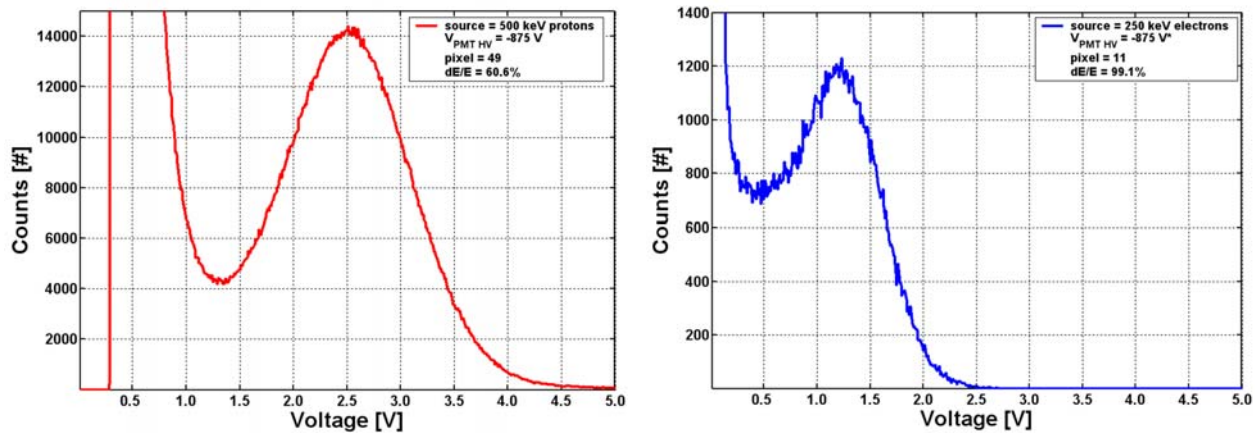

Figure 9. Proton (left) and electron (right) energy resolution.

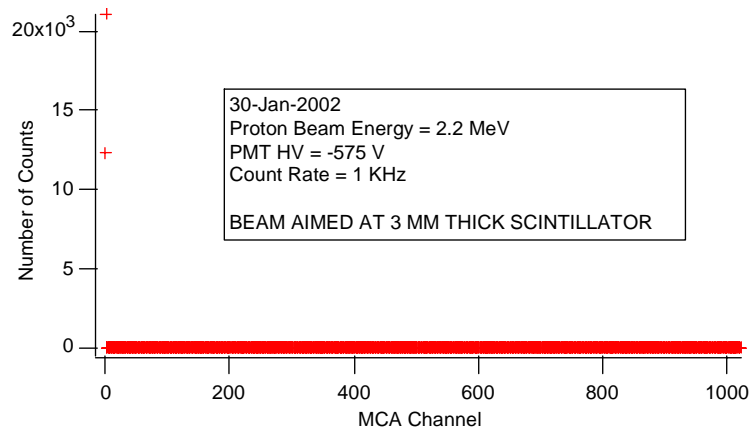

Figure 10. Response of the electron scintillator to irradiation with 2.2 MeV protons.

A compelling aspect of the LIPS concept is its flexibility. The design is completely adaptable to different energy regimes - and different missions. By simply changing the scintillator thickness and materials, the LIPS can be configured to monitor the higher energy trapped radiation and solar proton environments. We envision the LIPS as a basic nanosatellite core sensor that can easily be configured to monitor the space weather environment in a variety of orbits and environments – from LEO to GEO, from the van Allen belts to the magnetotail.

Acknowledgements

This work was funded under Air Force Small Business Innovative Research Phase II Contract No. F19628-01-C-0017.

References

1. J.L. Horwitz, "The Ionospheric Wild Ride in Outerspace," *Rev. Geophys.* **33** (1995).
2. D.C. Hamilton, G. Gloecher, F.M. Ipavich, W. Studemann, B. Wilken, and G. Krenser, "Ring Current Development During the Great Geomagnetic Storm of February 1986," *J. Geophys. Res.* **93**, 14, 343 (1988).
3. L.R. Lyons and D.S. Evans, "The Inconsistency Between Proton Charge Exchange and the Observed Ring Current Decay," *J. Geophys. Res.* **78**, 4731 (1976).
4. K.L. Bedingfield, R.D. Leach, and M.B. Alexander, "Spacecraft System Failures and Anomalies Attributed to the Natural Space Environment," NASAS RP-1390 (1996).
5. *Handbook of Geophysics and The Space Environment*, ed. A. Jursa (1983).
6. G.E. Galica, B.D. Green, F. Scire-Scappuzzo, H.E. Spence, J.D. Sullivan, B.K. Dichter and D.L. Cooke, "Scintillator-based Ring Current Imager for NanoSatellites," AIAA Paper 2001-0237, 39th AIAA Aerospace Sciences Meeting & Exhibit, 8-11 January 2001, Reno, NV.
7. G.E. Galica, B.D. Green, F. Scire-Scappuzzo, H.E. Spence, J.D. Sullivan, B.K. Dichter and D.L. Cooke, "Scintillator-based Ring Current Imager for NanoSatellites," 7th Spacecraft Charging Technology Conference (2001: A Spacecraft Charging Odyssey), 23-27 April 2001, ESTEC, Noordwijk, The Netherlands.
8. G. Gloecher and D.C. Hamilton, "The Change-Energy-Mass (CHEM) spectrometer for 0.3 to 300 keV/e ions on AMPTE/CCE," *IEEE Trans. Geosci. Remote Sens.*, **GE-23**, 234 (1985).
9. R.W. Nightingale, R.R. Vandrak, E.E. Gains, W.L. Inhof, R.M. Robinson, S.J. Battel, D.A. Simpson, and J.B. Reagan, "CRRES Spectrometer for Electrons and protons," *J. Spacecraft* **29**, 614 (1992).