

Validation of a wireless optical layer for on-board data communications

Patrice Pelissou, EADS ASTRIUM Toulouse

Asuncion Santamaria, Francisco José Lopez Hernandez, UPM

Patrick Plancke, Inmaculada Hernandez Velasco, ESA

1. Introduction

This study was conducted in 2003/2004 under ESA contract 16431/02/NL/EC. The objective was to assess the feasibility of an intra-satellite communication using a wireless optical network. The study includes:

- The review of existing technologies
- The space and spacecraft environment
- The design, manufacturing and test of demonstrators

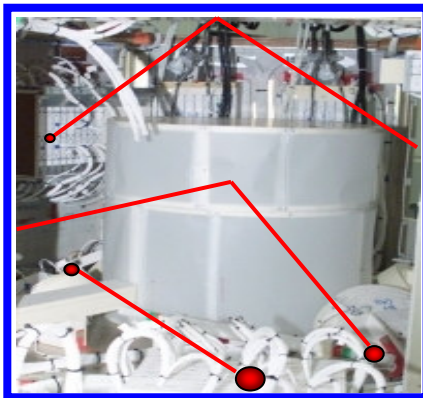

Today objective:

Feasibility in S/C environment.

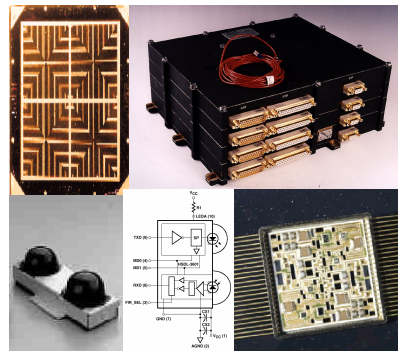

Next step:

Development of space products

2. Architecture of a wireless system

Wireless networks can offer attractive solution for removing a part of the harness for both low and high speed links. The objective is now to demonstrate that a wireless network can work with sufficiently high margins inside a satellite and that tools and analysis methodology is available, in the same way as it is done today do for wired data links. In this frame, **EADS ASTRIUM and UPM** have developed **three wireless demonstrators** based on COTS hardware and softwares.

Report Documentation Page

Form Approved
OMB No. 0704-0188

Public reporting burden for the collection of information is estimated to average 1 hour per response, including the time for reviewing instructions, searching existing data sources, gathering and maintaining the data needed, and completing and reviewing the collection of information. Send comments regarding this burden estimate or any other aspect of this collection of information, including suggestions for reducing this burden, to Washington Headquarters Services, Directorate for Information Operations and Reports, 1215 Jefferson Davis Highway, Suite 1204, Arlington VA 22202-4302. Respondents should be aware that notwithstanding any other provision of law, no person shall be subject to a penalty for failing to comply with a collection of information if it does not display a currently valid OMB control number.

1. REPORT DATE 13 JUL 2005	2. REPORT TYPE N/A	3. DATES COVERED -	
4. TITLE AND SUBTITLE Validation of a wireless optical layer for on-board data communications		5a. CONTRACT NUMBER	
		5b. GRANT NUMBER	
		5c. PROGRAM ELEMENT NUMBER	
6. AUTHOR(S)		5d. PROJECT NUMBER	
		5e. TASK NUMBER	
		5f. WORK UNIT NUMBER	
7. PERFORMING ORGANIZATION NAME(S) AND ADDRESS(ES) EADS Astrium Toulouse, France		8. PERFORMING ORGANIZATION REPORT NUMBER	
9. SPONSORING/MONITORING AGENCY NAME(S) AND ADDRESS(ES)		10. SPONSOR/MONITOR'S ACRONYM(S)	
		11. SPONSOR/MONITOR'S REPORT NUMBER(S)	
12. DISTRIBUTION/AVAILABILITY STATEMENT Approved for public release, distribution unlimited			
13. SUPPLEMENTARY NOTES See also ADM001791, Potentially Disruptive Technologies and Their Impact in Space Programs Held in Marseille, France on 4-6 July 2005., The original document contains color images.			
14. ABSTRACT			
15. SUBJECT TERMS			
16. SECURITY CLASSIFICATION OF:			17. LIMITATION OF ABSTRACT
a. REPORT unclassified	b. ABSTRACT unclassified	c. THIS PAGE unclassified	UU
			18. NUMBER OF PAGES 16
			19a. NAME OF RESPONSIBLE PERSON

The demonstrators are representative of a spacecraft configuration including both platform and payload equipment simulations. The demonstrator architecture includes the following units:

- The OBC that controls the entire network. It sends the commands to equipments and receives data from them.
- The AOCS and μ RTUs equipments that are part of the critical platform bus. These equipments generate a low data rate (few kilobits per second).
- A medium data rate payload equipment that generate data for up to 1 Mbps.
- A high rate payload instrument generating up to 100 Mbps.

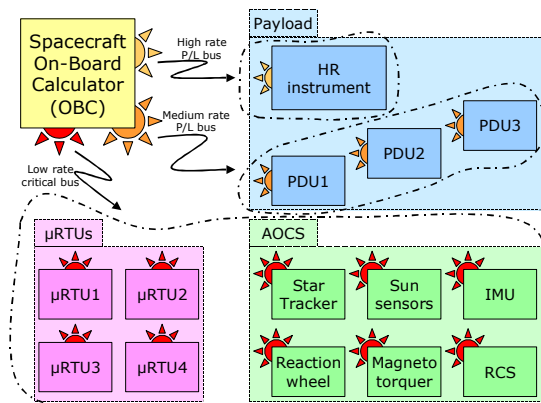

3. Review of technologies

Hardware existing products

Several companies interested in wireless IR systems for data communications have joined together to form a common organization called IrDA (Infrared Data Association). The aim of IrDA is to create and promote interoperable, low-cost infrared data interconnection standards that support walk-up point-to-point user models. The standards developed by IrDA can be used in many data communications applications, such as communications between PCs and peripheral devices, digital image exchange, communications between mobile devices, modem access or exchange between MP3 players and computers. Bit rates using IrDA standards started with 9600 b/s to 115 kb/s. Later specifications deal with data rates of 2 Mb/s, 4 Mb/s and 16 Mb/s.

More than 130 companies make up the IrDA membership.

COMPANY	IR emitter	IR receiver	IR transceiver	IrDA product	Software	Develop ment kits	Indoor system
Agilent Technologies	•	•		•			
ACTISYS				•	•		
Amp Inc				•			
Cirrus Logic			•				
Clairax Technologies	•	•					
Elcos	•						
Extended systems					•	•	
Fairchild semiconductor	•	•					
Hamamatsu	•	•					
Hewlett-Packard				•			
Hitachi	•						
Irvine sensors				•			
Kodenshi			•				
Lasermate group	•						
Microship						•	
National Semiconductors				•			
NVG inc	•						
Optek technology	•	•					
Optodiode corp	•						
Osram	•	•					
Roithner Lasertechnik	•						
Semiconductor Laser International	•						
Standard Microsystem				•			
Siemens Comp				•			
Traveling software				•	•		
Temic semiconductor				•			
Vishay intertechnology	•	•	•	•			
Wireless communication products							•
Xantech					•		
Zilog				•			

Software

Software tools are very important in managing the hardware that allows IR wireless communications to take place. The software providers offer a wide range of programs for managing IrDA ports, and which are easy to include in the O.S. Notice that the two most important PC O.S. suppliers (Microsoft and Linux) are involved in the development of tools for wireless IR communications.

COMPANY	OS/OS extensions/ Protocol Stacks /drivers	Development Tools	Consultant services	Application programming
3Com	●	●	●	●
Access	●			
ACTISYS	●	●	●	
Calibre	●			
Eastman-Kodak	●			
EMBEDnet Inc.	●			
Extended	●	●	●	●
Extended Systems	●			
FCC Limited	●			
Geoworks	●			
Hewlett-Packard	●			
Linux	●			
Microsoft	●			
Microware	●			
Motorola	●	●		
Norand	●	●	●	●
Okaya Systems	●	●		
Open Interface	●		●	●
Parallax	●		●	
Phoenix	●	●		
Puma	●	●		●
Questra			●	●
REUDO	●			●
TEMIC	●			
Trace Research	●			

Performances of the IR products

Most IR products are compliant with the IrDA standard.

For point-to-point link, commercial products based on laser techniques offer rates as high as 100 Mbps over distance exceeding 1000m.

Performance	Value	Comments
Bit rate	Up to 4 MHz	FIR standard large choice of products (optical head) Micro-controller interface not available for a network communication
	Up to 16 Mhz	VFIR standard. Some optical head products announced.
Emitter irradiance	0.1 to 0.5W/sr	
Irradiance half angle	15° to 30°	
Emitter sensitivity	Close to 0.04W/m ²	Sensitivity is better for low rates
Link distance	1 to 5 meters	The standard guaranty is 1 m

4. Space environment

The optical wireless system design shall take into account the space environment constraints to ensure that the effects do not degrade the system performances.

Space radiation

The space radiation environment can lead to extremely harsh operating conditions for the electronic on-board equipment's and systems.

The characteristics of the radiation environment are highly dependent on the type of mission (date, duration and orbit). Radiation accelerates the aging of the EEE parts and material and can lead to a degradation of electrical performances; it can also create transient phenomena on EEE parts. Such a damage at electronic part level can induce damage or functional failure at equipment and system levels.

The space radiation environment can be split into two major components, depending on the effects generated on electronics parts : **long term effects** (Total Ionizing Dose and Displacement Damage) and **transient effects** (Single Event Phenomena (SEP)).

. **Today no IrDA are space qualified.**

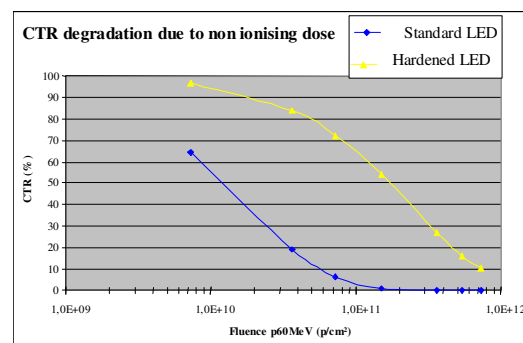
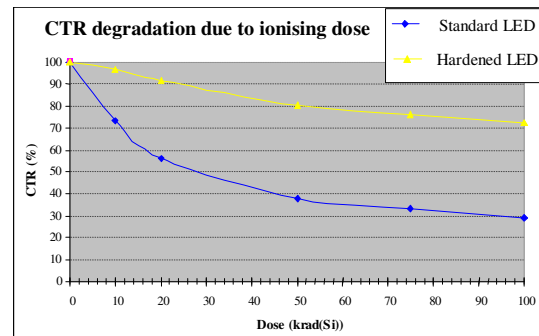

Temperature/ageing effect

The spacecraft and its equipments are submitted to a thermal environment with important temperature transitions. The equipment shall be designed to maintain the internal components in acceptable temperatures when the equipment itself is at its functioning temperature limits. **The IrDA products are compliant with the specifications.**

Ageing effects will be also considered. The problem is more critical in light sources than in other components, especially when the junction temperature is high. To prevent this ageing phenomenon, significant power **derating factor** are generally applied, limiting the performance of the devices.

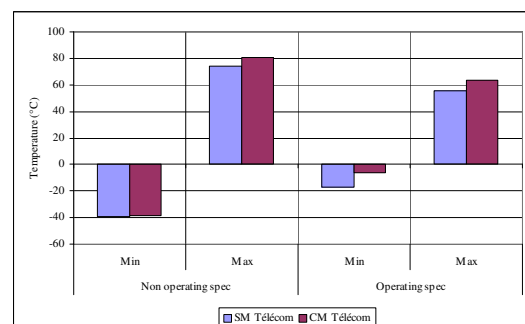

5. Spacecraft environment

The goal is to verify that the architecture of the considered system is compatible with this wireless application. So considering a given spacecraft platform and given IR emitters and receptors, the objective is to verify that a signal emitted by the emitter will be correctly received by the receiver.

The simulation for the budget link analysis

Based on the internal geometry and coatings characteristics, the link budget is assessed between an emitter and a receiver following a standard ray-tracing technique.

The 3D simulations have been performed on three satellites with different size:

- a **small one** with an avionics system gathered in one compartment where the central part is often occupied by the propellant tanks, and the equipment distributed over the inner side of the surrounding spacecraft walls. The typical size of this type of platform is around one meter.
- a **medium one** with a compartmented implementation of the inner part of the platform. The interconnectivity of the different units in various compartments implies the use of repeaters. The size of the cavities nevertheless remains small.
- a **large telecommunication one** (e.g. Eurostar type) with an avionics distributed over several compartments. The size, architecture and the equipment implementation are here again different. This type of platform is large, with an avionics distributed over several compartments (4 service module compartments, and several other compartments). The interconnectivity of the different units requires **repeaters**.

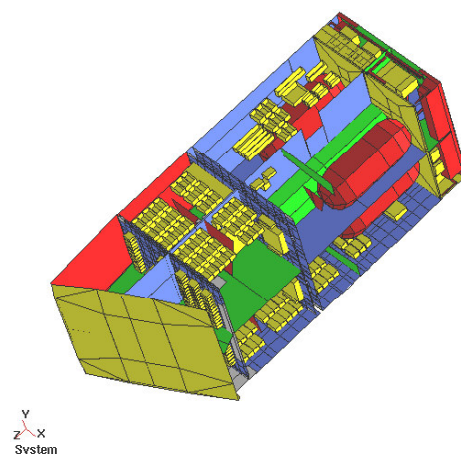
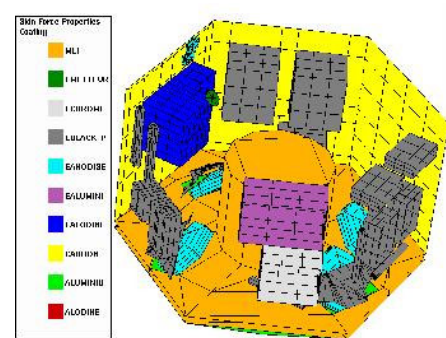
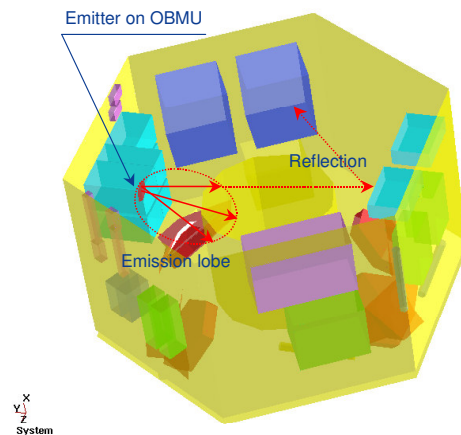

Main simulations results

Link budget

The link budget in **direct line of sight** is in general achieved. It is easily checked by the formula:

$$P_{inc}(W/m^2) = \frac{P(W/sr)}{d^2}.$$

For the small spacecraft, the link budget between one emitter and all other units using reflections on walls is insured for an emitter **power higher than 1W** and an emission **half angle of 20°** and with a receiver threshold close to **0.04 W/m²**.

In an optimized configuration (all white panted walls), the required minimum emitter power is 0.4W and receiver threshold < 0.04W/m².

For the medium spacecraft, the independent cavities are smaller than small satellites ones so the **conclusions are identical**. The use of **repeaters** between each cavity is so necessary.

For the big spacecraft, the link budget is only insured in direct line of sight for an emitter power higher than **1W** and an emission half angle **of 20°** and with a receiver threshold close to **0.04 W/m²**.

Effect of implementation

To insure the link budget between one emitter and several receivers inside the spacecraft, the simulation results show the emitter power need **is today not available on the market**. This is mainly due to presence of hidden and blind zones inside the satellite which are not directly seen by the emitter. To improve this link budget with COTS components, the solution is to use **repeaters** which allow the communications between emitter and receiver that are not in direct line of sight by means of retransmitting each received optical pulse.

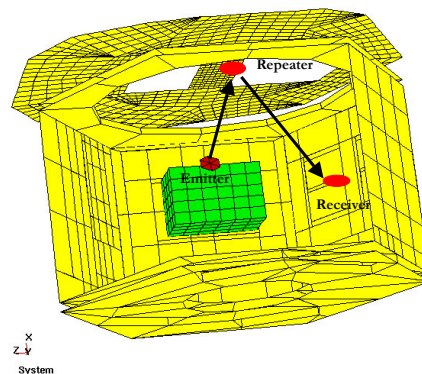
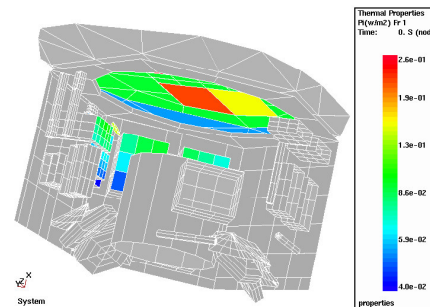
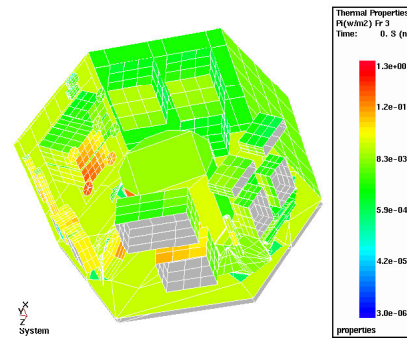

Effect of material properties

The different simulations show that the link budget is closely dependant of the inner coatings optical characteristics due to reflections on walls. In order to optimize the link budget, the thermal and optical constraints must be taken into account. The use of **black paint** to coat the inner walls and equipments is mostly guided by the search of material with a high epsilon (i.e. emission and absorption in the thermal IR range): typically $\epsilon > 0.85$. But white paints have also a high epsilon, altogether with a low solar absorptivity, which is of little importance for inner materials not subjected to solar flux, but of high interest for wireless communication!

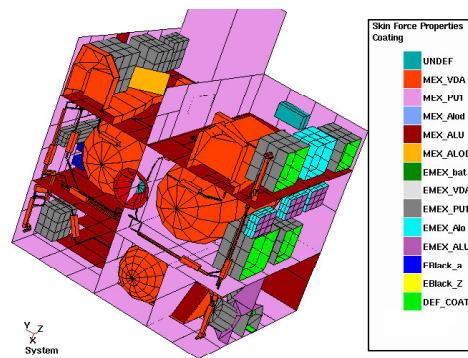

	Solar absorptivity α	IR emissivity ϵ	Reference
PSB Peinture Silicate Blanche	0.12	0.88	Fiche technique MAP RS 102
PSG 11FD	0.13	0.8	RS 107
PSG 10FD	0.13	0.8	RS 113

Other effects

Infrared emitters with signal rates inferior to 10Mbps do not induce **multi-path** issue in the case of small satellite.

Concerning the interference **environment light**, the fluorescent lighting specification of IrDA is compatible with the typical lighting used in clean room.

Moreover, the **solar lighting** specification (10000 lux) imposes that no IR receiver should be in direct line of the sun. This induces specific design rules at structure apertures level.

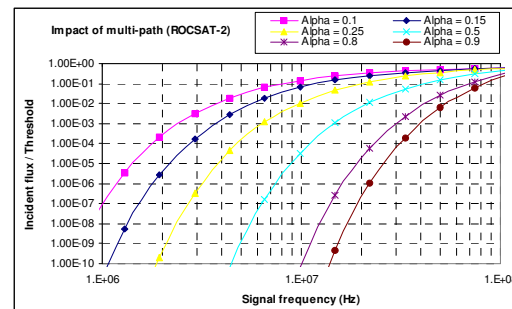

Point to point communications

For the specific point to point communication case, where the communication rate is higher (100Mbps) and the emitted power also, the communication beam is more collimated in order to concentrate the emitted power on the receiver, avoid multi-path effects and minimize the diffused parasitic light. But this design induces **alignment constraints** which need to be integrated in the integration procedures.



6. Demonstrators architecture

Hardware architecture

The traffic is decomposed in three parts: a low, a medium and a high data rate in order to support the communication between the main calculator and the equipments using a bus topology and a point-to-point high data rate link:

- The **low rate data** bus architecture is a multi-points link at **115kbps using 10 receivers**; 10 repeaters are also used to insure the link budget inside the spacecraft.

The Central Unit and the Remote Units are connected to two portable computers to control the communication and to configure the network operation mode.

This network complies with the SIR IrDA standard.

- The **medium rate data** bus architecture is a point-to-point link at physical layer level (**1Mbps**) The transmitter sends a random bit stream from a signal generator, to the receiver. At the receiver's side, the eye diagram of the received bit stream is visualized using an oscilloscope. From this eye diagram the error probability of the link is calculated.

- The **high rate data bus** architecture is a point-to-point link with communication protocol (**100Mbps**) A high data rate link connects two 100BASE-T PC cards through a bi-directional point-to-point link. An application for file transfer from one terminal to the other is done. This application runs on the portable computers and allows the user to start and stop transmissions and to select the data to be transmitted.

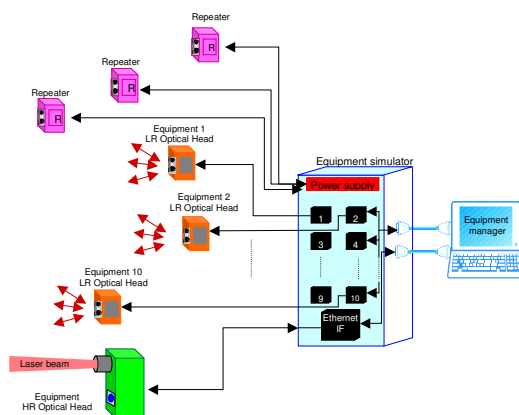
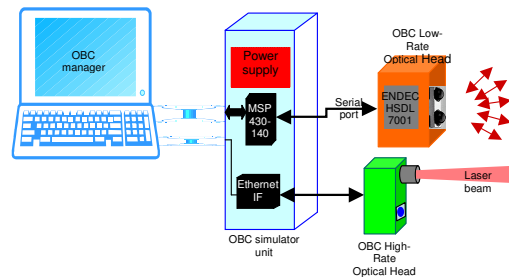

Low data rate optical heads

Transceivers

Each low rate optical head is individually connected to the Simulator Unit by mean of a serial interface. The LROH optical emitted power can be programmed by the user during the scenario definition (maximum power (P_{max}), $2/3$ of P_{max} , $1/3$ of P_{max} or no power).

The LROH optical transceivers are the **Agilent's IrDA chip-set HSDL-3602 and HSDL-7001**.



Repeaters

The Repeaters are designed to re-send each optical pulse they receive, avoiding retransmission loops. This means that each received pulse is retransmitted only once. Repeaters are individually powered from the Equipment Simulator Unit. The Repeater optical emitted power can be selected to maximum emitted power (P_{max}), $2/3$ of P_{max} , $1/3$ of P_{max} or no power by means of two micro-switches included in the box. The Repeater optical transceiver is **the Agilent's IrDA HSDL-3612**.



Medium data rate optical head

The transmitter sends a random bit stream from a signal generator, to the receiver.

To avoid the connection of additional equipment (generator), the random bit stream generator has been included in the MROH-Tx. It has been implemented in a programmable logic device (Xilinx - XC9536XL) that generates a Maximum Length Sequence Code (MLS Code). The code is generated from a 16 bits generator, and this gives a MLS code of $(2^{16}-1)$ bits length.

The MROH emitter is composed of 6 diodes **ELD840525** in series.

The MROH receiver is an **IPL10050 photodiode**.



High data rate optical head

The High Rate Link (HRL) connects two Ethernet 10/100 BASE-T PC cards through a bi-directional wireless IR point-to-point link built using laser diodes. Any commercial 10/100 Ethernet PC card can be used and installed in two portable computers. Two High Rate Optical Heads (HROHs) have been designed and built to perform the Ethernet signal conversion from electrical to optical format and vice versa.



The laser diode is a **SLD65018250ST (from Samsung Semiconductors)**.

The photodiode used in the wireless link is the **S8223 (from Hamamatsu)** that has been integrated in a RXI concentrator (from LPI Europe) to make the alignment process easier.

The **OBC simulator unit** and the **Equipment Simulator Unit** are composed of three main parts:

- The Power Supply: this unit is connected to the mains and supplies the voltages necessary for the electronic circuits.
- The Interfaces Board includes: communication ports with the laptop, connection with the high rate optical heads, powering the medium rate optical heads, power supply connections for repeaters, connection to microcontrollers.
- The microcontroller units: each of them, for its part, is composed of two boards: the MSP-FET 430 Flash Emulation Tool and the Adaptation Board. The Adaptation Board has been designed to provide access to the microcontroller that is mounted on the Emulation Tool.

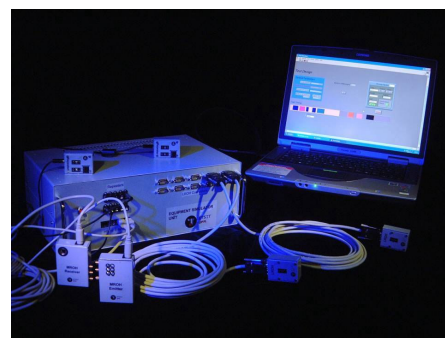

Software architecture

The demonstrators support two protocols. A first protocol is used on the **low-rate data bus**. It permits the data exchanges between a main calculator and several equipments. The second protocol supports the data exchanges between the main calculator and **high data rate** equipment.

The **low-rate data bus protocol** decomposes the data exchanges in two parts. The first part is purely synchronous as the second part is asynchronous.

The synchronous communication protocol allows to roughly simulate the use of standard data buses as the MIL-STD 1553B or more recently the CAN in space systems. Most of the treatments performed on the main calculator are synchronous and required appropriate inputs. All the data exchanges are initiated by the main calculator (master) that emits a command to a single equipment (slave) at precise times. The equipment is authorized to answer using a predefined message format. All the exchanges are defined in term of timing and content. The length of the message must be configurable.

The asynchronous communication allows to simulate the behavior of standard data buses used on ground as 802.3 (LAN) and 802.11 (Wireless LAN). All the data exchanges are initiated by the equipments. The main difference between the synchronous and asynchronous transmission lies in the **collisions** that can happen in the asynchronous mode. When a collision happens than the action is the rejection of frames involved on it and the avoidance of transmission when an equipment detects that the channel is busy. On the other hand, two equipments can start their transmissions simultaneously. To detect frames with errors due to collisions a 32-bits CRC field is added to the frame format. When an equipment receives a message with an error in the CRC, that message will be marked as wrong message and will be delivered to the test environment.

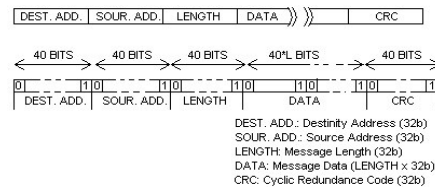
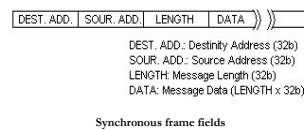
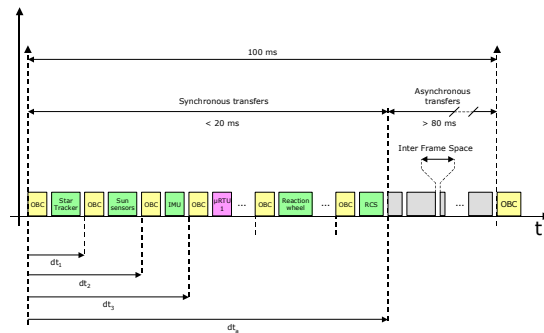

Asynchronous frame

7. Demonstrators validation

Introduction

The main objective of this project is to demonstrate the validity of wireless data communication within a spacecraft. The optical communication network is so **tested** on a representative satellite environment using a **satellite mock-up** which is representative of the flight one in term of dimensions, equipments number and materials properties except the units which have been made of white rigid foils whereas flight ones are covered by black paint. This difference has been taken into account in the simulations.

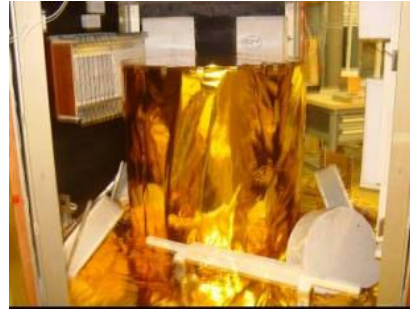

The validation process is constituted of three parts:

- first step, the **link budget simulations** are performed at system level in order to determine the emitter and receivers locations
- second, we **install the emitter** and receivers at the locations determined by the simulations
- at the final, we execute the communication **tests**.

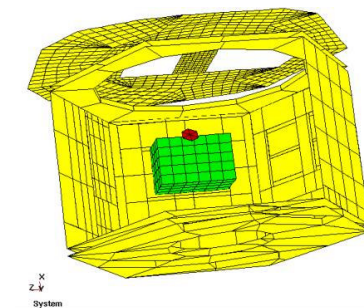

Simulation results

This test consists in placing the low rate emitter at the computer unit level (OBMU) and searching the optimal positions and orientations of the receivers to insure the link inside the spacecraft mock-up.

The emitter is placed on the OBMU and 30° oriented towards the upper floor. The computed flux at upper floor level due to OBMU emitter allows to determine the repeaters positions.

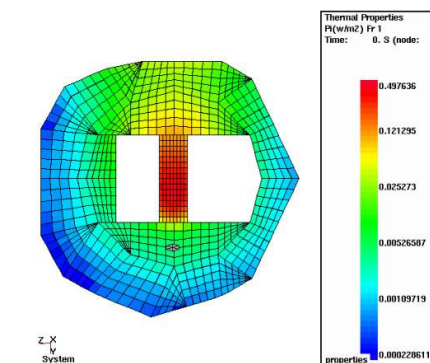

With a more accurate legend (the minimum corresponds to the receiver threshold), the zones where the link budget is insured are so determined.

The second step is to assess the number of repeaters allowing a complete coverage of all receivers. So, **five repeaters** are necessary to insure the link budget

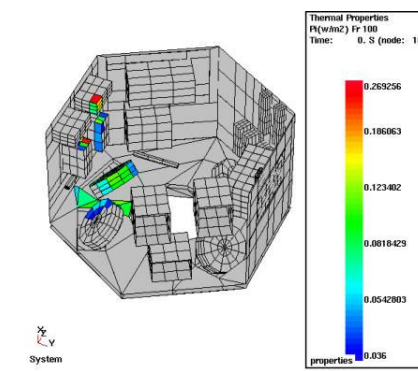
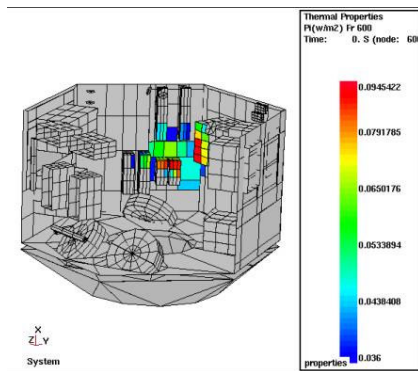
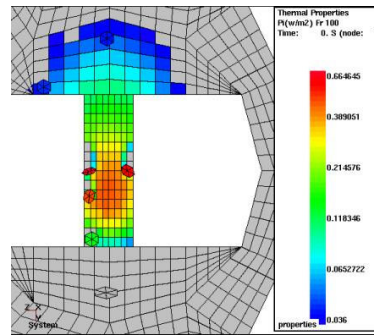

Test results

Link budget

A good correlation has been found between the test results and the simulations ones. Considering the emitter/receiver and repeaters locations determined by simulations, the test results have demonstrated **100% coverage** inside the spacecraft using 5 repeaters.



Link budget for low data rate system

A two-way **synchronous** communication is performed with cycles beginning by a broadcast of the master (OBC) then a request to each slaves (equipments: T1 to T10) followed by an answer of those same equipments.

The test results can be summarized with the figure on the right where “R” means a good reception; “T” means a transmission, and the number means the emitter number.

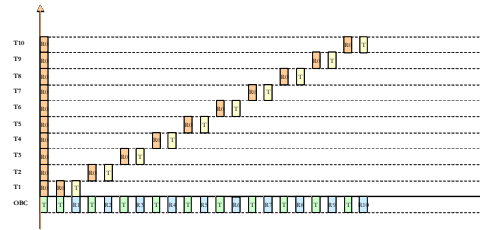

An **asynchronous** communication means that all the data exchanges are initiated by the equipments towards the master (OBC). Thanks to repeaters, the communication inside the spacecraft is so insured with a **100% coverage**.

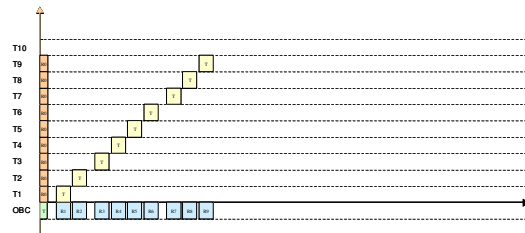

Collision management

The scenario is to make a communication from one unit (T1) to the master (OBC) during a long slot where other transmissions are sent in the same time.

When a collision happens, the action is the rejection of frames involved on it and the avoidance of transmission when an equipment detects that the channel is busy

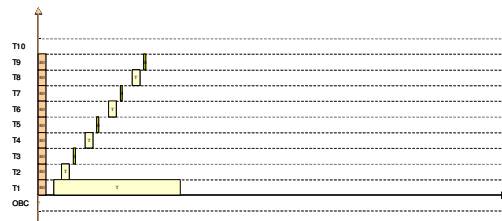

On the other hand, two equipments can start their transmissions simultaneously. To detect frames with errors due to collisions a 32-bits CRC field is added to the frame format. When an equipment receives a message with an error in the CRC, a message is marked as wrong message and is delivered to the test environment.

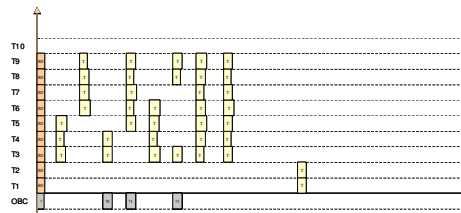

Medium data rate system

The medium data rate bus is tested at the physical level. Once established the data rate (1 Mb/s), the key parameter is the **bit error rate** (BER). It is assessed thanks to the **eye diagram** which estimates the link performance: the Signal-to-Noise ratio is defined from the eye diagram amplitude V_{pp} and

noise rms values σ as: $\frac{S}{N} = \left(\frac{V_{pp}}{2\sigma} \right)^2$. The BER can

be related to the values of the eye diagram as:

$$P_e = Q\left(\frac{V_{pp}}{2\sigma}\right) = Q\left(\sqrt{\frac{S}{N}}\right).$$

The 6 emitter LEDs in series allow to insure the link budget with **90% coverage** inside the spacecraft **without repeater!**

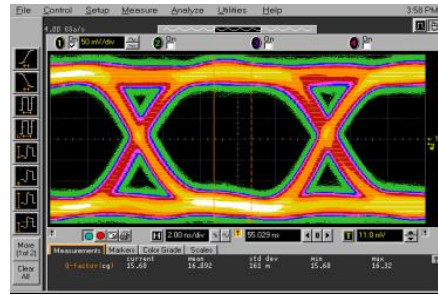

High data rate system

Due to the low dimensions of the spacecraft cavity, the communication in direct line of sight is always insured. For hidden zones, the reflection on walls can insure the link budget but contrary to the medium rate system, **only one receiver position** can see the emitter beam due to the restricted emission angle.

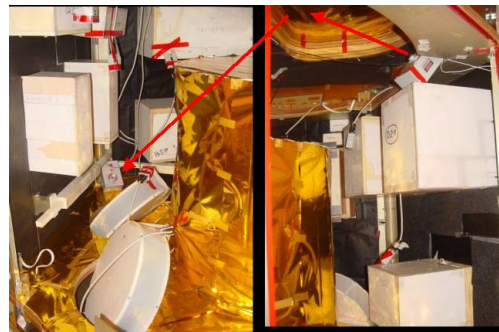

8. Conclusion

From the review of the state of the art and experimental results on demonstrators, we can conclude that:

- The components, technologies and techniques required to insure the link budget inside the spacecraft exist today. Nevertheless, an important effort is necessary to manufacture and qualified such a system in a grade compatible with the space constraints. It can be done within few years.
- The system process in term of link budget assessment is well-mastered thanks to good correlations between simulation and test results. Some materials characterizations are nevertheless necessary to improve the simulations.
- Some optical wireless applications are attractive:
 - Security improvement: for particular application (military spacecraft), the optical beam has an advantage with regards to the RF signals.
 - EMC safety
 - Harness mass gain for digital bus and for specific applications where the spacecraft performances require shielding and over-shielding cables.
 - AIT (Assembly, Integration and Test) improvement for ground application (minimization of the test harness)

