



H. KOCH & SONS CO.



Development of a Mobile Aircrew Webbing Retractor System



Roger Podob
NAVAIR

Tel. (301) 342-8444

Chris Culbertson
H. Koch & Sons
Tel. (714) 779-7000

NAVAL AVIATION TECHNOLOGIES



Report Documentation Page

Form Approved
OMB No. 0704-0188

Public reporting burden for the collection of information is estimated to average 1 hour per response, including the time for reviewing instructions, searching existing data sources, gathering and maintaining the data needed, and completing and reviewing the collection of information. Send comments regarding this burden estimate or any other aspect of this collection of information, including suggestions for reducing this burden, to Washington Headquarters Services, Directorate for Information Operations and Reports, 1215 Jefferson Davis Highway, Suite 1204, Arlington VA 22202-4302. Respondents should be aware that notwithstanding any other provision of law, no person shall be subject to a penalty for failing to comply with a collection of information if it does not display a currently valid OMB control number.

| | | | |
|---|------------------------------------|--|----------------------------------|
| 1. REPORT DATE SEP 2004 | 2. REPORT TYPE N/A | 3. DATES COVERED - | |
| 4. TITLE AND SUBTITLE Development of a Mobile Aircrew Webbing Retractor System | | 5a. CONTRACT NUMBER | |
| | | 5b. GRANT NUMBER | |
| | | 5c. PROGRAM ELEMENT NUMBER | |
| 6. AUTHOR(S) | | 5d. PROJECT NUMBER | |
| | | 5e. TASK NUMBER | |
| | | 5f. WORK UNIT NUMBER | |
| 7. PERFORMING ORGANIZATION NAME(S) AND ADDRESS(ES) NAVAIR 48110 Shaw Road, Bldg 2187 Suite 1280 Patuxent River, MD | | 8. PERFORMING ORGANIZATION REPORT NUMBER | |
| 9. SPONSORING/MONITORING AGENCY NAME(S) AND ADDRESS(ES) | | 10. SPONSOR/MONITOR'S ACRONYM(S) | |
| | | 11. SPONSOR/MONITOR'S REPORT NUMBER(S) | |
| 12. DISTRIBUTION/AVAILABILITY STATEMENT Approved for public release, distribution unlimited | | | |
| 13. SUPPLEMENTARY NOTES Published in the Proceedings of the Forty Second Annual SAFE Association Symposium, Held in the Salt Lake City, Utah, September 27-28, 2004. SAFE Association, Post Office Box 130, Creswell, OR 97426-0130. http://www.safeassociation.org , The original document contains color images. | | | |
| 14. ABSTRACT | | | |
| 15. SUBJECT TERMS | | | |
| 16. SECURITY CLASSIFICATION OF: | | | 17. LIMITATION OF ABSTRACT |
| a. REPORT unclassified | b. ABSTRACT unclassified | c. THIS PAGE unclassified | SAR |
| | | | 18. NUMBER OF PAGES 15 |
| | | | 19a. NAME OF RESPONSIBLE PERSON |



H. KOCH & SONS CO.

Background



NAVAL AVIATION TECHNOLOGIES





H. KOCH & SONS CO.

System Requirements

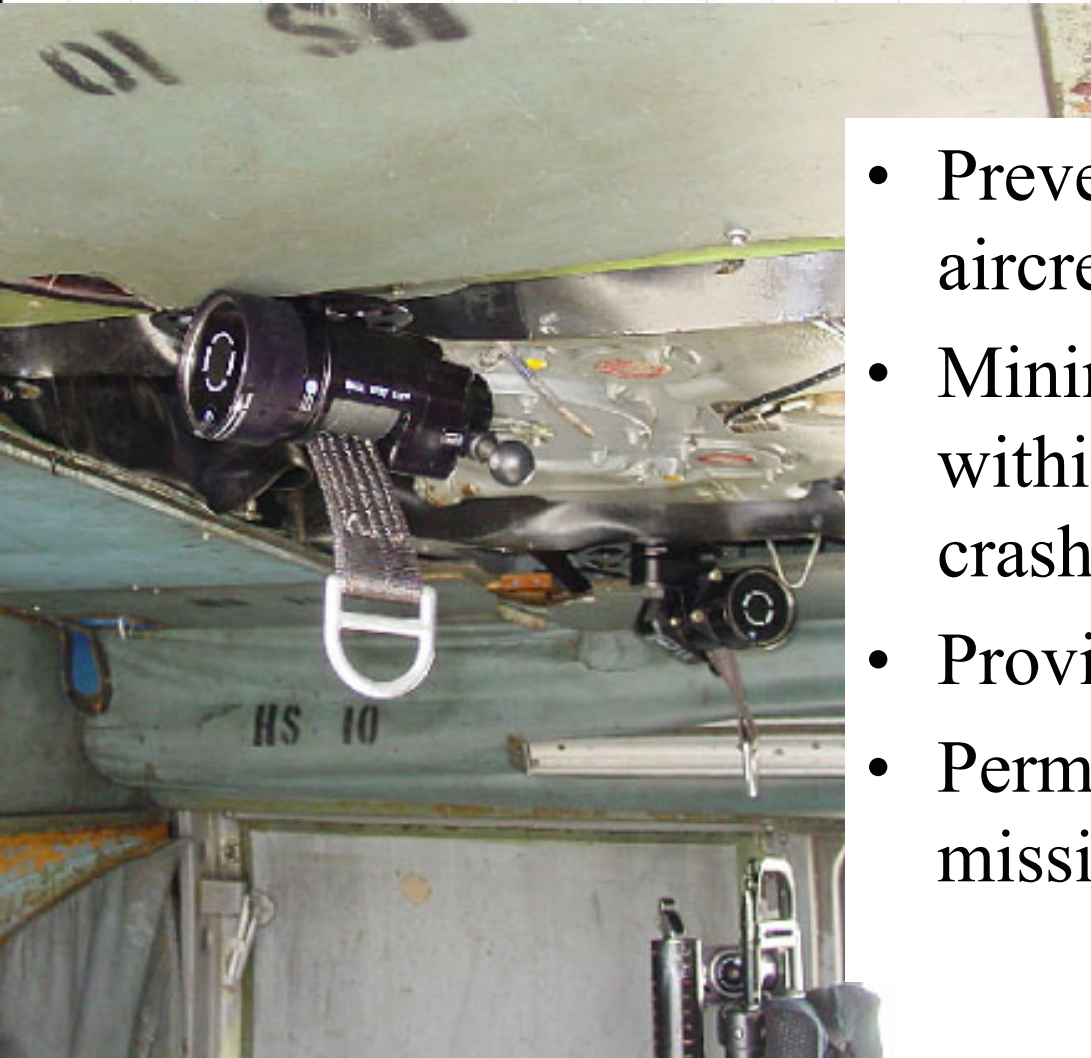

- Prevent ejection of cabin aircrew in survivable crashes.
- Minimize strike envelope within cabin in survivable crashes.
- Provide in-flight fall protection.
- Permit aircrew mobility for mission duties.





H. KOCH & SONS CO.



Two Systems



- H-60 MAWR
 - Interim solution
 - Modified gunner's belt
 - Modified webbing retractor
- Common System
 - Integration into AIRSAVE lifting harness
 - Accommodate large cabin aircraft





H. KOCH & SONS CO.

Current System Disadvantages

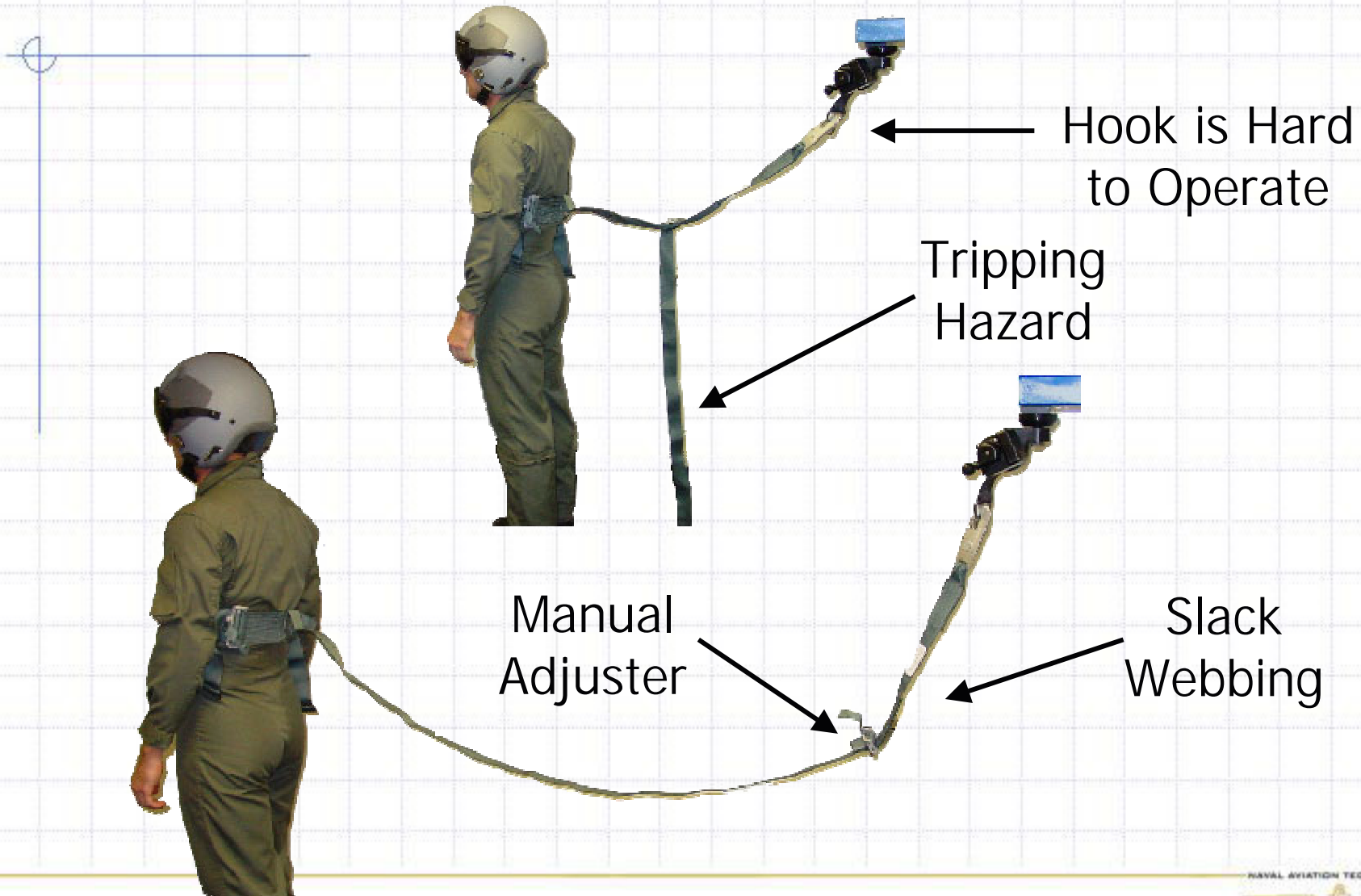



H. KOCH & SONS CO.

System Components



- Modified Gunner's Seat Webbing Retractor
- Modified Gunner's Belt
 - Slide adjuster removed
 - New snap hook

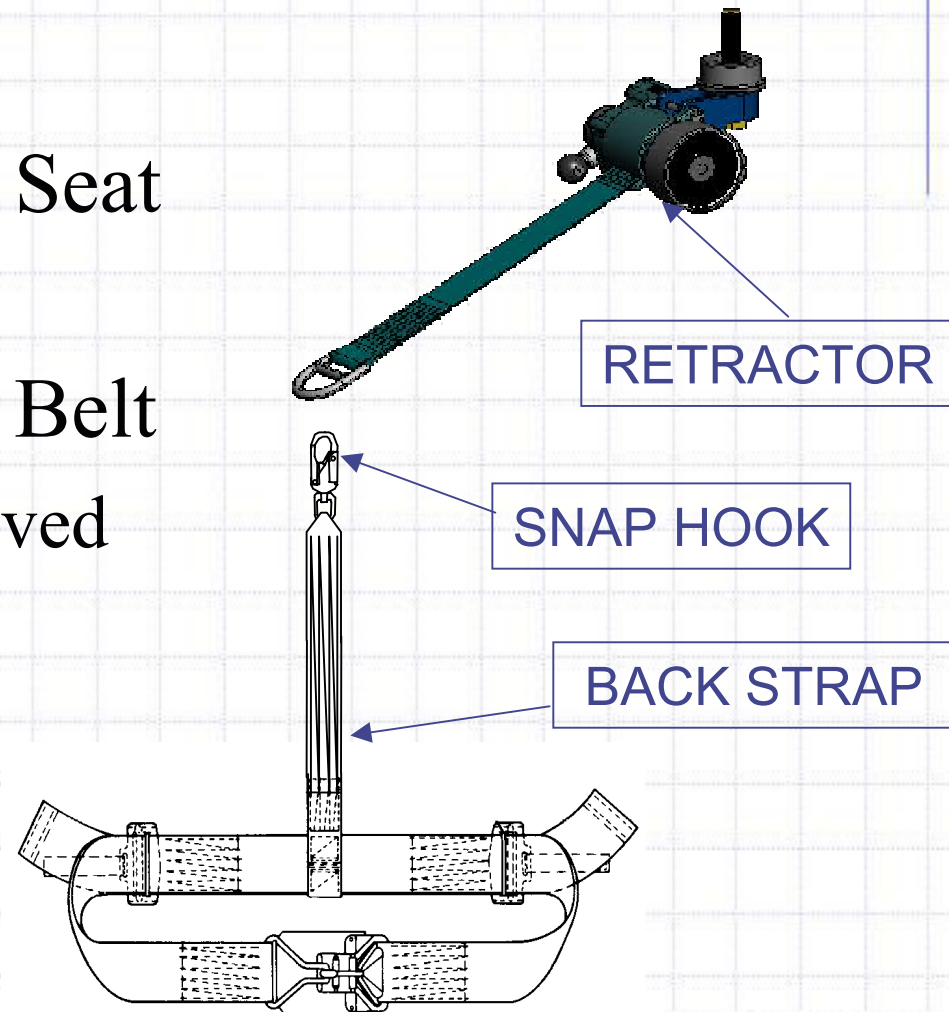



H. KOCH & SONS CO.

Retractor Components

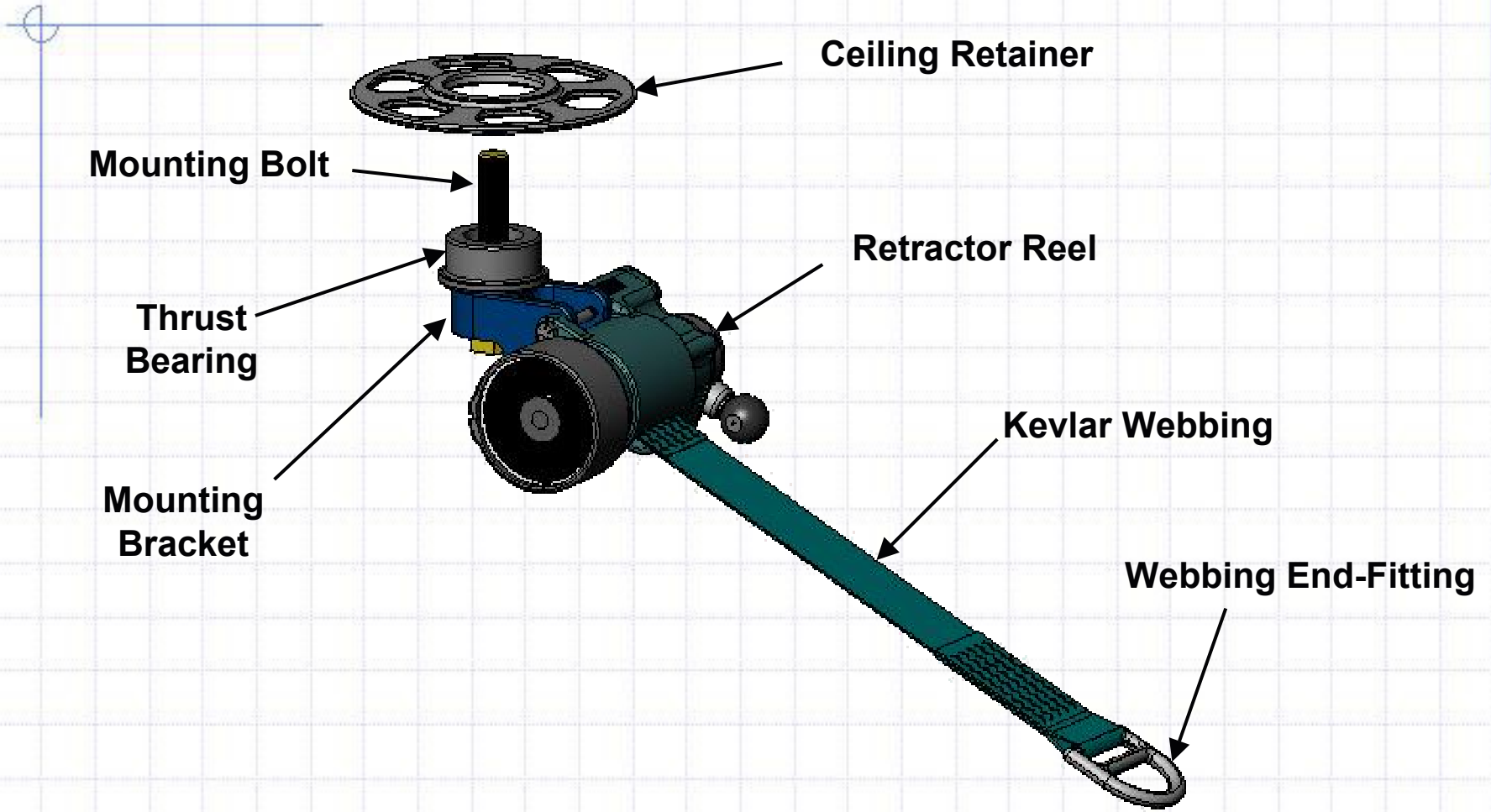



H. KOCH & SONS CO.



Webbing Retainer

- Replaces Molded End Design
- Aluminum Alloy Retaining Bar
- High Strength Kevlar Stitching
- Tensile Tested to > 6000 lb

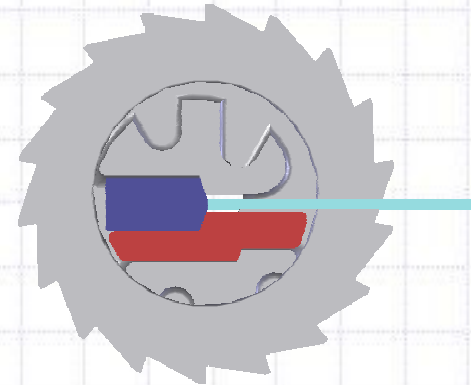

MA-8/16 Design

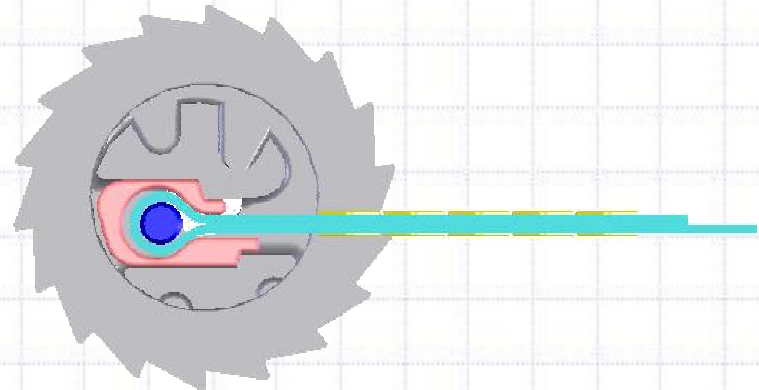
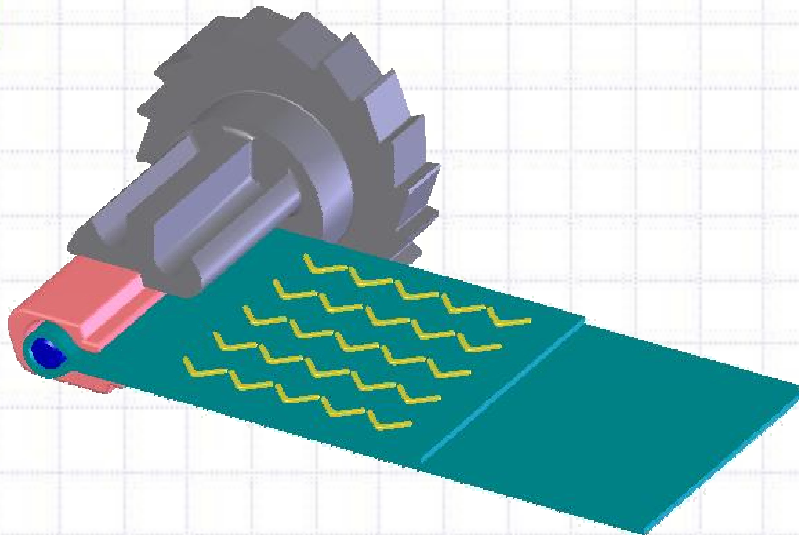

MAWR Design





H. KOCH & SONS CO.



New System Advantages

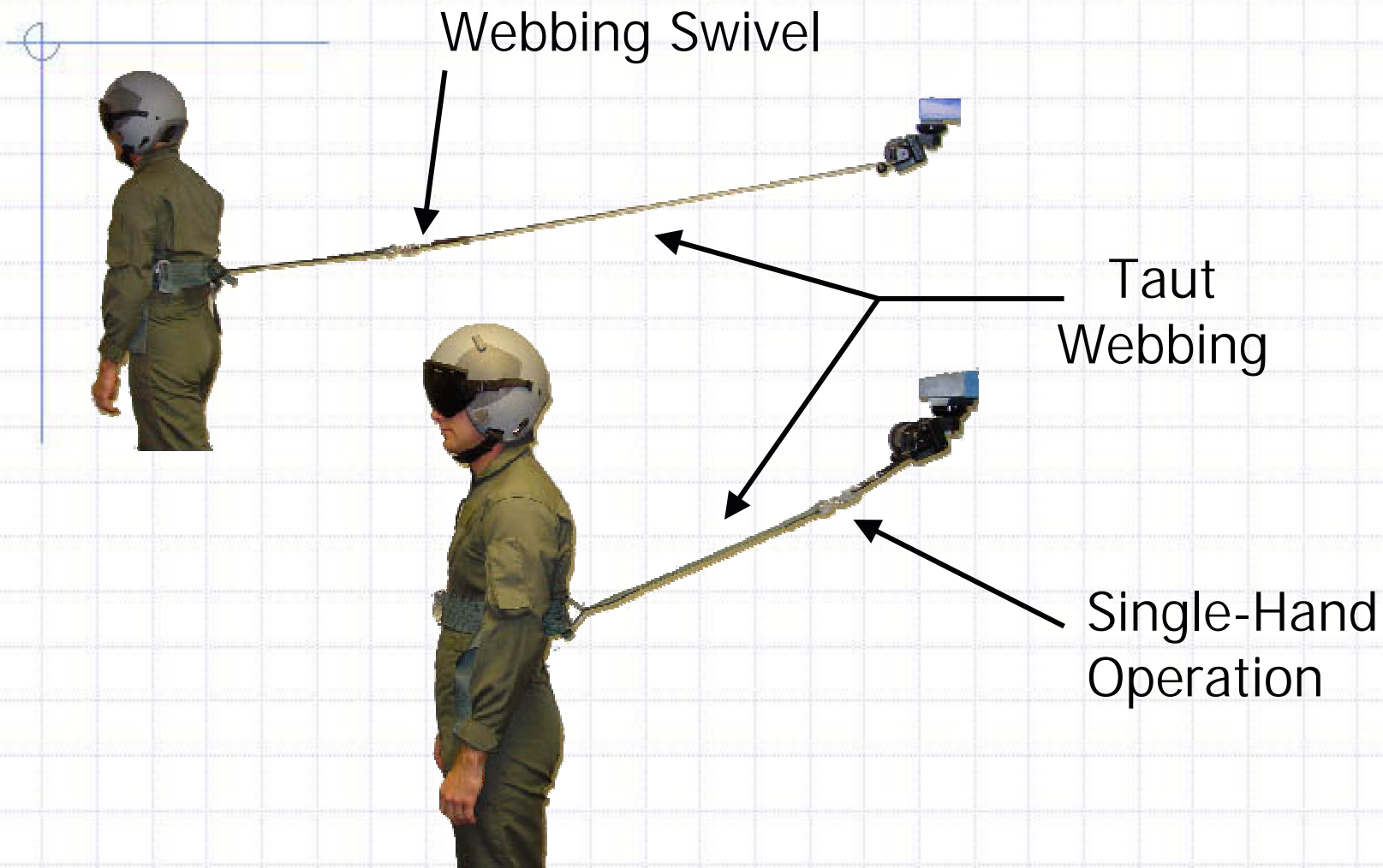



H. KOCH & SONS CO.

Computer Simulations

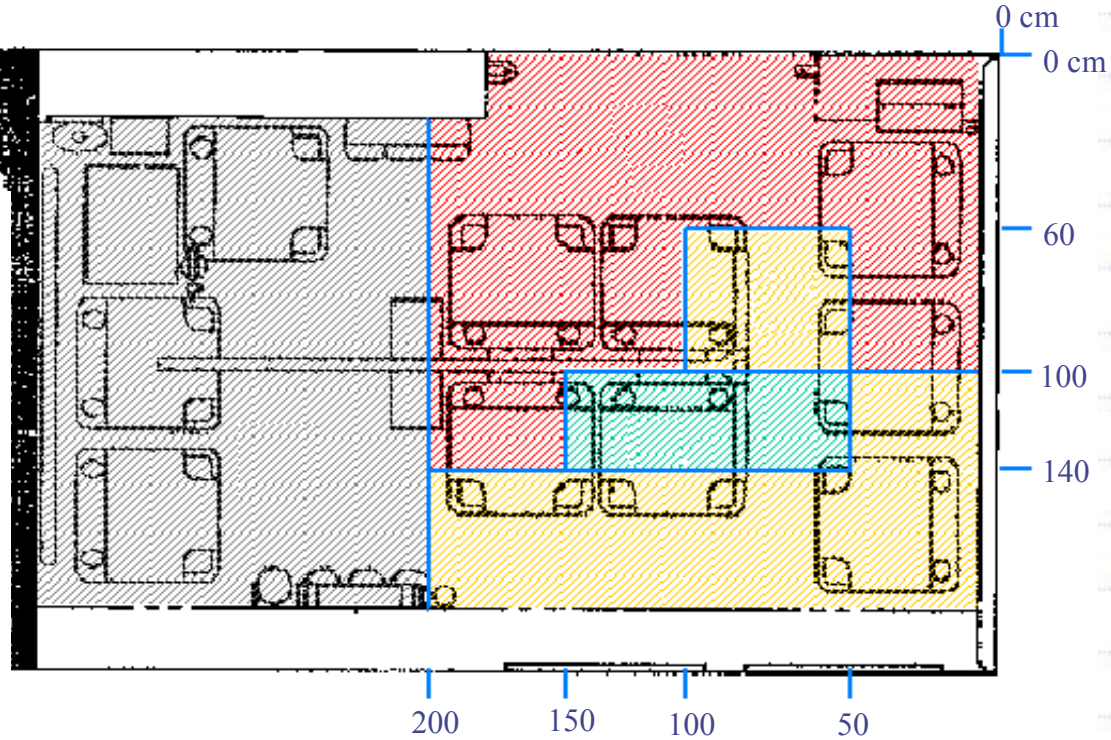

- Grid of 24 anchor points
- Several crash pulses applied to each point
- Kinematics of crewmember evaluated
- Each anchor point was scored
 - Good
 - Moderate
 - Unacceptable





H. KOCH & SONS CO.



Computer Simulations

Time = 0.000000

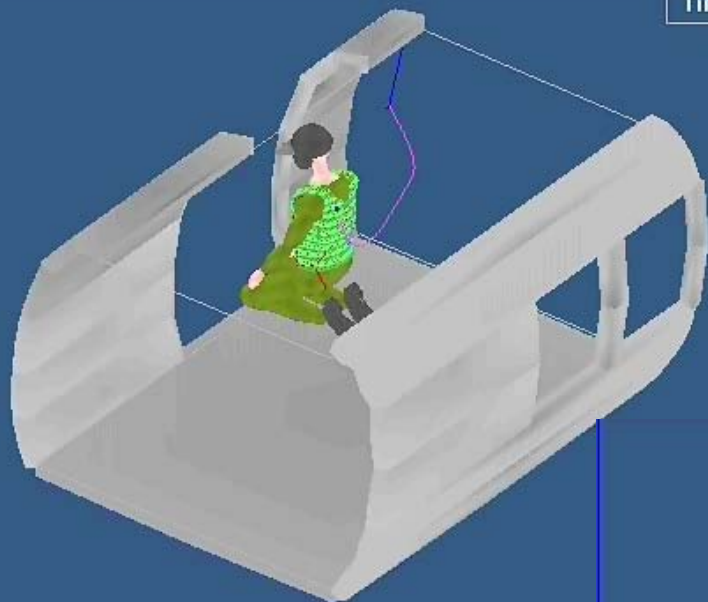

Without MAWR



Time = 0.000000

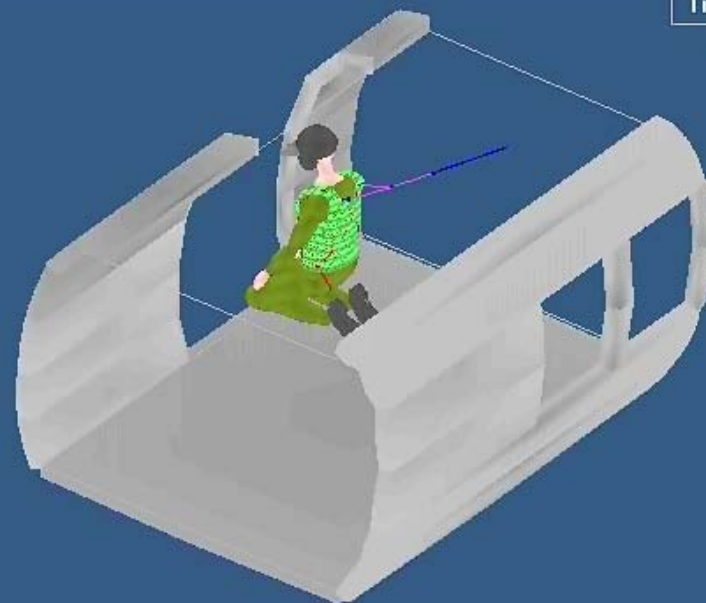

With MAWR



Pulse: 20Gz, 10Gxy (at 45°)





H. KOCH & SONS CO.



Dynamic Tests

- 12 Horizontal Accelerator Tests
 - 10G, 32 ft/sec pulse
 - Forward and sideward orientations
 - Upstream and downstream of retractor
 - 5% female and 95% male
 - Armor provided slight chest compression improvement





H. KOCH & SONS CO.



Dynamic Tests

- 12 Drop Tests
 - 5% female and 95% male
 - 10.9" average payout to lock
(2" to 17" range)
 - Retractors of 3 different sensitivities used
 - Armor provided slight chest compression improvement



NAVAL AVIATION TECHNOLOGIES





H. KOCH & SONS CO.

Ground and Flight Testing



- Ground Evaluations
 - SH-60B, F, F+, HH-60H
 - No nuisance locking
 - Entanglement was reduced
- Flight Testing
 - System was nearly invisible to aircrew





H. KOCH & SONS CO.



Thank You

Questions?



NAVAL AVIATION TECHNOLOGIES

