

STATIC AND DYNAMIC FINITE ELEMENT ANALYSIS OF SANDWICH STRUCTURES

by

J. F. Abel* and E. P. Popov**
University of California, Berkeley, California

The finite element method is extended to the refined elastic analysis of multilayer beams and shells with no restriction placed upon the ratios of the layer thicknesses and properties. The method is applicable to structures wherein shearing deformations are significant, including sandwich-type structures. Element stiffnesses developed are based on polynomial displacement models and are applicable to the linear elastic analysis of beams and thin, axisymmetric shells of arbitrary meridian. Although attention is restricted to three-layered construction with similar facings, the theory may be generalized for any type of flexural element and any arrangement of laminations. Computer programs have been written for both static analysis and free vibration analysis. Inclusion of rotary as well as translational inertia allows determination of natural thickness-shear frequencies and mode shapes in addition to flexural vibration characteristics. Examples are presented to illustrate the effectiveness of the method.

*Presently First Lieutenant, U. S. Army Corps of Engineers; formerly Graduate Student, Department of Civil Engineering.
**Professor of Civil Engineering.

Report Documentation Page

Form Approved
OMB No. 0704-0188

Public reporting burden for the collection of information is estimated to average 1 hour per response, including the time for reviewing instructions, searching existing data sources, gathering and maintaining the data needed, and completing and reviewing the collection of information. Send comments regarding this burden estimate or any other aspect of this collection of information, including suggestions for reducing this burden, to Washington Headquarters Services, Directorate for Information Operations and Reports, 1215 Jefferson Davis Highway, Suite 1204, Arlington VA 22202-4302. Respondents should be aware that notwithstanding any other provision of law, no person shall be subject to a penalty for failing to comply with a collection of information if it does not display a currently valid OMB control number.

1. REPORT DATE OCT 1968	2. REPORT TYPE	3. DATES COVERED 00-00-1968 to 00-00-1968	
4. TITLE AND SUBTITLE Static and Dynamic Finite Element Analysis of Sandwich Structures		5a. CONTRACT NUMBER	
		5b. GRANT NUMBER	
		5c. PROGRAM ELEMENT NUMBER	
6. AUTHOR(S)		5d. PROJECT NUMBER	
		5e. TASK NUMBER	
		5f. WORK UNIT NUMBER	
7. PERFORMING ORGANIZATION NAME(S) AND ADDRESS(ES) Air Force Flight Dynamics Laboratory, Wright Patterson AFB, OH, 45433		8. PERFORMING ORGANIZATION REPORT NUMBER	
9. SPONSORING/MONITORING AGENCY NAME(S) AND ADDRESS(ES)		10. SPONSOR/MONITOR'S ACRONYM(S)	
		11. SPONSOR/MONITOR'S REPORT NUMBER(S)	
12. DISTRIBUTION/AVAILABILITY STATEMENT Approved for public release; distribution unlimited			
13. SUPPLEMENTARY NOTES See also AD0703685, Proceedings of the Conference on Matrix Methods in Structural Mechanics (2nd) Held at Wright-Patterson Air Force Base, Ohio, on 15-17 October 1968.			
14. ABSTRACT			
15. SUBJECT TERMS			
16. SECURITY CLASSIFICATION OF:			17. LIMITATION OF ABSTRACT
a. REPORT unclassified	b. ABSTRACT unclassified	c. THIS PAGE unclassified	18. NUMBER OF PAGES 34
			19a. NAME OF RESPONSIBLE PERSON

SECTION I

INTRODUCTION

Multilayer construction has become more and more important in structural engineering as one means of achieving a beneficial combination of the properties of two or more materials. The best known examples of this type are the widespread "sandwich" structures used in the aerospace industry. These combine thin, high-strength facing layers with a thicker, light-weight core.

The theory of stress analysis of multilayer structures is well established. In general, two classifications of such structures can be identified: (1) "laminates" in which layers of materials with similar properties are bonded together and for which the Kirchhoff-Love hypothesis is applied and (2) "sandwiches" in which some layers may be significantly weaker than others and for which transverse shear deformation is taken into account. Theory for the laminates (Reference 1) has been successfully applied to analysis of general plates and shells using, for example, the approximate methods of finite differences (Reference 2) and finite elements (Reference 3). However, despite the availability of sandwich theories of various degrees of refinement in the literature, there have been relatively few solutions published that include the effects of transverse shear (Reference 23). Moreover, these solutions have been restricted to the simpler geometries such as rectangular and circular plates and cylindrical and spherical shells.

The purpose of this present paper is to extend the finite element method to the analysis of sandwich beams and shells. Although specific solutions are to be presented here only for axisymmetric shells, the same general approach, using existing standard finite element techniques, will permit the analysis of arbitrary configurations and boundary conditions.

Extensive reviews and bibliographies of the theory of sandwich structures are presented in References 4 through 6. In the present work, a theory analogous to Yu's sandwich theory is adopted (Reference 7). This theory places no restriction on the ratios of layer thicknesses and material properties, and it includes the bending and stretching effects and the transverse shear flexibility of all layers. Yu has applied this formulation to vibrational problems of sandwich structures, including both shear and rotatory inertia (References 8 and 9).

The finite element method was developed concurrently with the increasing use of high-speed electronic digital computation and its concomitant emphasis on discretized techniques

in structural analysis. In general, the method has proved to be a successful tool for the systematic analysis of complex structures and the approximate solution of difficult problems in continuum mechanics. Among the large number of publications on the finite element method to appear in the last decade, References 10 and 11 include descriptions of the basic techniques and comprehensive bibliographies.

Because of the importance of the problem, considerable attention has been devoted to the finite element analysis of axisymmetric shells. This class of problems has the inherent simplification of a one-dimensional mesh. For the analysis the conical frustra as elements have been widely used (References 12 through 14). Recently, the more accurate axisymmetric types of doubly curved elements have been introduced (References 15 through 17). In this paper, the doubly curved element developed by Khojasteh-Bakht (Reference 17) is utilized. This element duplicates the position, slope, and curvature of the original structure at each nodal circle. In addition, this element appears to be satisfactory from the point of view of the Irons-Draper conditions of completeness and compatibility (Reference 18). In this development, polynomial displacements are assumed and the direct stiffness method is employed.

The following assumptions apply throughout this paper:

1. Displacements and strains are sufficiently small so that the linear theory of elasticity applies.
2. Perfect bonding occurs between adjacent layers of the structure.
3. The transverse displacement of all layers is the same at a given location of the middle surface of the structure. In other words, there is no pinching deformation.
4. Shells are thin in the sense that products of thickness with curvature are much smaller than unity ($\zeta/R \ll 1$).
5. Material lines in each layer originally straight and normal to the neutral surface remain straight after deformation, but no longer remain normal. The difference in shear strain in the several layers manifests itself in warping of the cross section at the interfaces.
6. The materials of each layer are linearly elastic and the procedure can be applied to orthotropic materials. However, for simplicity, the discussion in this paper is confined to an isotropic case.

7. The bending and stretching of all layers are taken into account. However, this assumption can be relaxed for a particular layer by assigning a zero Young's modulus.

8. All layers are flexible in shear (see item 5 above) but this assumption can be relaxed for a particular layer by assigning an infinite shear modulus.

SECTION II

SANDWICH BEAM ELEMENT

A sandwich beam element of unit width which is symmetric about the middle surface of the core is shown in Figure 1. A normalized coordinate is defined

$$\xi = (x - x_i) / (x_j - x_i) = (x - x_i) / \ell$$

where the subscripts identify the i th and j th nodes of the element of length ℓ . The slope of beam can be divided into contributions due to pure bending deformation and pure shearing deformation as follows:

$$\frac{dw}{dx} = \chi = \chi_b + \chi_s \quad (1)$$

Under the above assumptions the shear strain of each layer is independent of the thickness coordinate z . The shear strains of the faces and core are indicated by γ_f and γ_c , respectively. Figure 2 shows a differential element deforming under pure shearing of the core and the facings. With this type of deformation there is no net extension of the layers, so the axial displacement of each middle surface is zero. The axial displacement of the interface must be the same when computed with reference to the middle surface of either the face or core. For the case of constant shear carried entirely by the core, this condition gives

$$u(z = h_c/2) = (\gamma_c - \chi_{sc}) h_c/2 = \chi_{sc} h_f/2$$

and for the case of face shearing it gives

$$u(z = -h_c/2) = (\gamma_f - \chi_{sf}) h_f / 2 = \chi_{sf} h_c / 2$$

Adding the two equations and using $d = h_c + h_f$, one obtains

$$\chi_s = \chi_{sc} + \chi_{sf} = \gamma_c h_c / d + \gamma_f h_f / d \quad (2)$$

χ_{sf} and χ_{sc} are defined in Figure 2.

As a result of the kinematic assumptions, the axial and transverse displacements of the beam may be written

$$\begin{aligned} u_c &= -z_c (\chi - \gamma_c) \\ u_f^{t,b} &= -z_f (\chi - \gamma_f) \pm \frac{d}{2} \chi \mp \frac{h_c}{2} \gamma_c \mp \frac{h_f}{2} \gamma_f \\ w_c &= w_f^t = w_f^b = w \end{aligned} \quad (3)$$

where the subscripts c and f indicate core and facings and the superscripts t and b indicate the top and bottom facings. z_c and z_f are thickness coordinates with origins at the middle surface of the respective layers. The strain-displacement equations for the beam are

$$\begin{aligned} \epsilon_{xc} &= \frac{du_c}{dx} = \epsilon_{xc}^o + z_c \kappa_{xc} \\ \epsilon_{xf}^{t,b} &= \frac{du_f^{t,b}}{dx} = \epsilon_{xf}^{o,t,b} + z_f \kappa_{xf}^{t,b} \\ \gamma_{zxc} &= \frac{du_c}{dz} + \frac{dw}{dx} = \gamma_c \\ \gamma_{zxf}^{t,b} &= \frac{du_f^{t,b}}{dz} + \frac{dw}{dx} = \gamma_f \end{aligned} \quad (4)$$

Substituting Equations 3 into Equations 4, the strain components that result are given by

$$\begin{aligned} \epsilon_{xc}^o &= 0 \\ \epsilon_{xf}^{o,t,b} &= \pm \frac{d}{2} \frac{d\chi}{dx} \mp \frac{h_c}{2} \frac{d\gamma_c^c}{dx} \mp \frac{h_f}{2} \frac{d\gamma_f}{dx} \\ \kappa_{xc} &= -\frac{d\chi}{dx} + \frac{d\gamma_c^c}{dx} \\ \kappa_{xf}^{t,b} &= -\frac{d\chi}{dx} + \frac{d\gamma_f}{dx} \end{aligned} \quad (5)$$

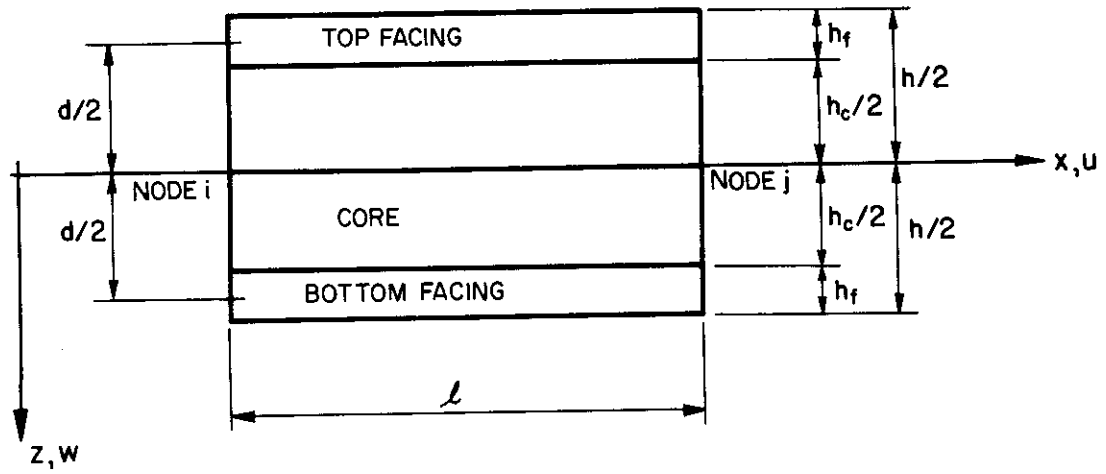

Figure 1. Typical Beam Element

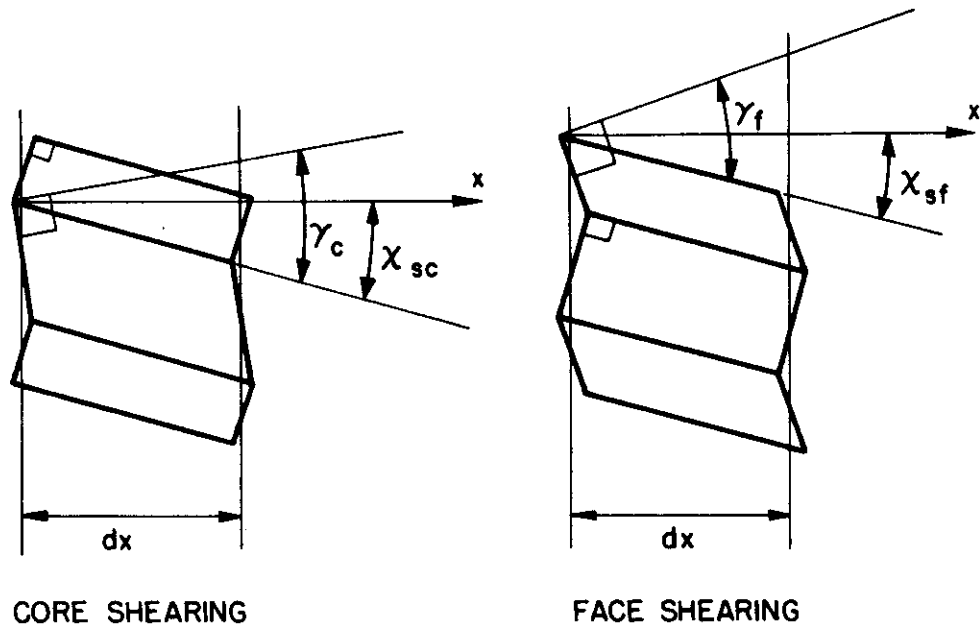

Figure 2. Slope Due to Shearing

Finally, the stress-strain equations in matrix form are

$$\sigma = \begin{Bmatrix} \sigma_{xc} \\ \tau_{zxc} \\ \sigma_{xf}^{\dagger} \\ \tau_{zxf}^{\dagger} \\ \sigma_{xf}^b \\ \tau_{zxf}^b \end{Bmatrix} = \begin{bmatrix} E_c & 0 & 0 & 0 & 0 & 0 \\ 0 & \lambda_c G_c & 0 & 0 & 0 & 0 \\ 0 & 0 & E_f & 0 & 0 & 0 \\ 0 & 0 & 0 & \lambda_f G_f & 0 & 0 \\ 0 & 0 & 0 & 0 & E_f & 0 \\ 0 & 0 & 0 & 0 & 0 & \lambda_f G_f \end{bmatrix} \begin{Bmatrix} \epsilon_{xc} \\ \gamma_{zxc} \\ \epsilon_{xf}^{\dagger} \\ \gamma_{zxf}^{\dagger} \\ \epsilon_{xf}^b \\ \gamma_{zxf}^b \end{Bmatrix} = C \epsilon \quad (6)$$

Here λ_c and λ_f are shear-stress correction factors analogous to that used in the Timoshenko beam theory. Yu (Reference 7) has suggested values very close to unity for sandwich construction with thin, heavy facings and a light, weak core. Since these are the properties characteristic of the vast majority of sandwich structures, these correction factors will hereafter be taken as unity. However, it should be noted that in a generalization of the present approach, further investigations are necessary to evaluate these parameters.

The beam element stiffness matrix is derived using a cubic transverse displacement field and a linear variation of shear rotation. Moreover, interpolation functions are used in order to express the displacement models directly in terms of the nodal displacements. Hence

$$u(\xi) = \Phi(\xi) q, \quad 0 \leq \xi \leq 1 \quad (7)$$

Here the vectors are chosen as

$$u^T = \langle w \ \chi \ \gamma_c \ \gamma_f \rangle$$

$$q^T = \langle u(0) \ \vdots \ u(1) \rangle$$

and thus the matrix Φ is given by

$$\begin{bmatrix} (1-3\xi^2+2\xi^3) & l\xi(1-2\xi+\xi^2) & 0 & 0 & \mid & \xi^2(3-2\xi) & l\xi^2(\xi-1) & 0 & 0 \\ 6\xi(\xi-1)/l & (1-4\xi+3\xi^2) & 0 & 0 & \mid & 6\xi(1-\xi)/l & \xi(3\xi-2) & 0 & 0 \\ 0 & 0 & (1-\xi) & 0 & \mid & 0 & 0 & \xi & 0 \\ 0 & 0 & 0 & (1-\xi) & \mid & 0 & 0 & 0 & \xi \end{bmatrix}$$

By applying Equations 4 and 5 to Equation 7, the strains may be expressed in terms of the nodal displacements

$$\epsilon(\xi) = B(\xi) q \quad (8)$$

where the strain-component vector is defined

$$\epsilon^T = \langle \kappa_{xc} \quad \gamma_{xzc} \quad \epsilon_{xf}^{o\uparrow} \quad \kappa_{xf}^{\uparrow} \quad \gamma_{xzf}^{\uparrow} \quad \epsilon_{xf}^{ob} \quad \kappa_{xf}^b \quad \gamma_{xzf}^b \rangle$$

Then consistent with the definitions in Equation 6, it is possible to write

$$\mathbf{e} = \mathbf{Z} \boldsymbol{\epsilon} = \begin{bmatrix} z_c & 0 & 0 & 0 & 0 & 0 & 0 & 0 \\ 0 & 1 & 0 & 0 & 0 & 0 & 0 & 0 \\ 0 & 0 & 1 & z_f & 0 & 0 & 0 & 0 \\ 0 & 0 & 0 & 0 & 1 & 0 & 0 & 0 \\ 0 & 0 & 0 & 0 & 0 & 1 & z_f & 0 \\ 0 & 0 & 0 & 0 & 0 & 0 & 0 & 1 \end{bmatrix} \boldsymbol{\epsilon} \quad (9)$$

The strain energy of the element is now given by

$$U = \frac{1}{2} \int_V \mathbf{e}^T \boldsymbol{\sigma} dV = \frac{1}{2} \mathbf{q}^T \int_0^1 \int_{-h/2}^{h/2} \mathbf{B}(\xi)^T \mathbf{Z}(z)^T \mathbf{C} \mathbf{Z}(z) \mathbf{B}(\xi) dz d\xi \mathbf{q}$$

Therefore, the element stiffness with reference to the displacements \mathbf{q} is

$$\mathbf{k}_{\mathbf{q}} = \int_0^1 \mathbf{B}(\xi)^T \int_{-h/2}^{h/2} \mathbf{Z}(z)^T \mathbf{C} \mathbf{Z}(z) dz \mathbf{B}(\xi) d\xi \quad (10)$$

The inner integral is readily recognized as a diagonal matrix involving the material properties and the areas and moments of inertias of the layers. The 8 x 8 stiffness matrix thus has five distinct components involving core bending and shear and facing bending, shear and extension. These are identified by the $E_c I_c$, $A_c G_c$, $E_f I_f$, $A_f G_f$ and $A_f E_f$ terms, respectively.

In assembling finite elements into a representation of an overall structure, compatibility usually must be maintained for all the displacement degrees of freedom occurring at the interelement nodes. However, when the transverse shear behavior is included, some continuity conditions must be removed in order to permit the "kinking" associated with discontinuities of the shear stress resultant. These discontinuities occur at transverse concentrated loads. Thus, the necessary and sufficient requirement for compatibility of the assemblage is interelement continuity on only the following nodal displacements:

1. the transverse displacement, w
2. the rotations of the normals to the reference surface (i. e., the rotations associated with pure bending), X_b

3. the shear warping angles at the interfaces, $\gamma = \gamma_c - \gamma_f$.

Hence, the stiffness k_q must be transformed so that it is expressed in terms of the following nodal displacements

$$r^T = \langle w_i \quad \chi_{bi} \quad \gamma_i \quad w_j \quad \chi_{bj} \quad \gamma_j \quad \gamma_{fi} \quad \gamma_{fj} \rangle. \quad (11)$$

The transformation is quite simple and can be constructed from the definitions

$$\gamma = \gamma_c - \gamma_f$$

$$\chi_b = \chi - h_c \gamma_c / d - h_f \gamma_f / d$$

The latter is obtained from Equation 2. A static condensation is performed on the resulting stiffness to obtain the 6 x 6 portion that is employed in the direct stiffness method.

It should be added that the nodal displacement parameters given in Equation 11 are also more advantageous than those of Equation 7 for expressing the boundary conditions necessary at a fixed support. At such a location, the transverse displacement w , the slope due to bending χ_b and the warping γ are all constrained to vanish, whereas the total slope χ and the shear strains γ_c and γ_f are non-zero.

An element stiffness has also been developed for a quadratic variation of shear strain by adding two degrees of freedom in shear at an internal node given by $\xi = 1/2$. The resulting 10 x 10 matrix is derived and transformed in a fashion exactly analogous to that for the linear shear element. In the quadratic case the static condensation is applied to the four "internal" degrees of freedom so the stiffness employed in the assembly process remains 6 x 6.

SECTION III

AXISYMMETRIC SANDWICH SHELL ELEMENT

The doubly curved element developed by Khojasteh-Bakht (Reference 17) is shown in Figure 3. Displacements in the local rectilinear coordinate system $\xi - \eta$ are designated by u_1 and u_2 . By matching the position, slope and curvature at the nodes, the geometry shown in the figure is substituted for that of a segment of an arbitrary rotational shell. Hence, the meridian of the substitute element is defined by the curve

$$\eta = \xi(1 - \xi)(a_1 + a_2 \xi + a_3 \xi^2 + a_4 \xi^3) \quad (12)$$

where ξ is a normalized coordinate which takes the values 0 and 1 at nodes i and j, respectively. The values of the constants are given by

$$a_1 = \tan \beta_i$$

$$a_2 = \tan \beta_i + \eta_i'' / 2$$

$$a_4 = 3(\tan \beta_i + \tan \beta_j) - (\eta_j'' - \eta_i'') / 2$$

$$a_3 = -(5 \tan \beta_i + 4 \tan \beta_j) + (\eta_j'' / 2 - \eta_i'')$$

$$\eta'' = \frac{d^2 \eta}{d \xi^2} = -\frac{l}{R_1 \cos^3 \beta}$$

$$\tan \beta = \eta' = \frac{d \eta}{d \xi}$$

The displacement transformation equations are also necessary:

$$\begin{aligned} u &= u_1 \cos \beta + u_2 \sin \beta \\ w &= u_1 \sin \beta - u_2 \cos \beta \end{aligned} \quad (13)$$

A sandwich element is depicted in Figure 4. Under axisymmetric loading, the rotation of the tangent to the meridian is given by

$$\chi = \frac{dw}{ds} + \frac{u}{R_1} \quad (14)$$

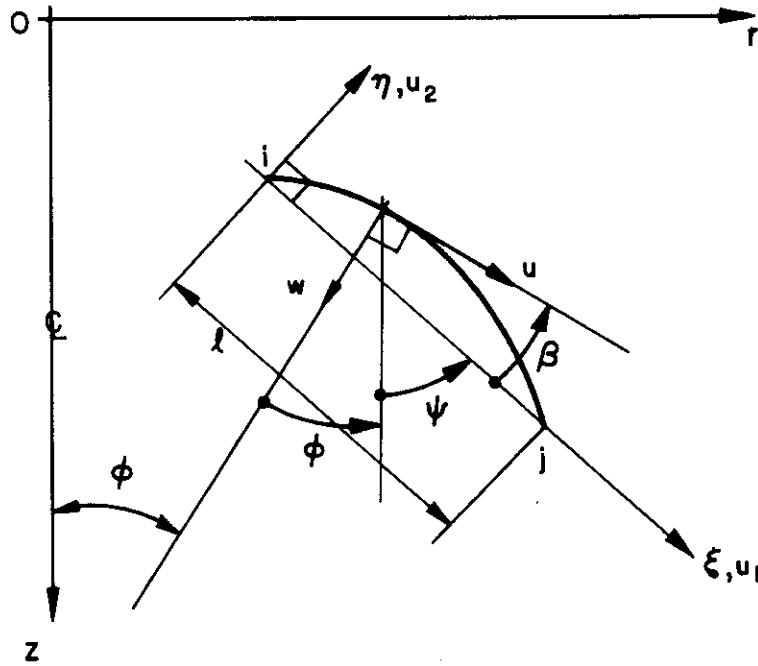

Figure 3. Doubly Curved Element after Khojasteh [17]

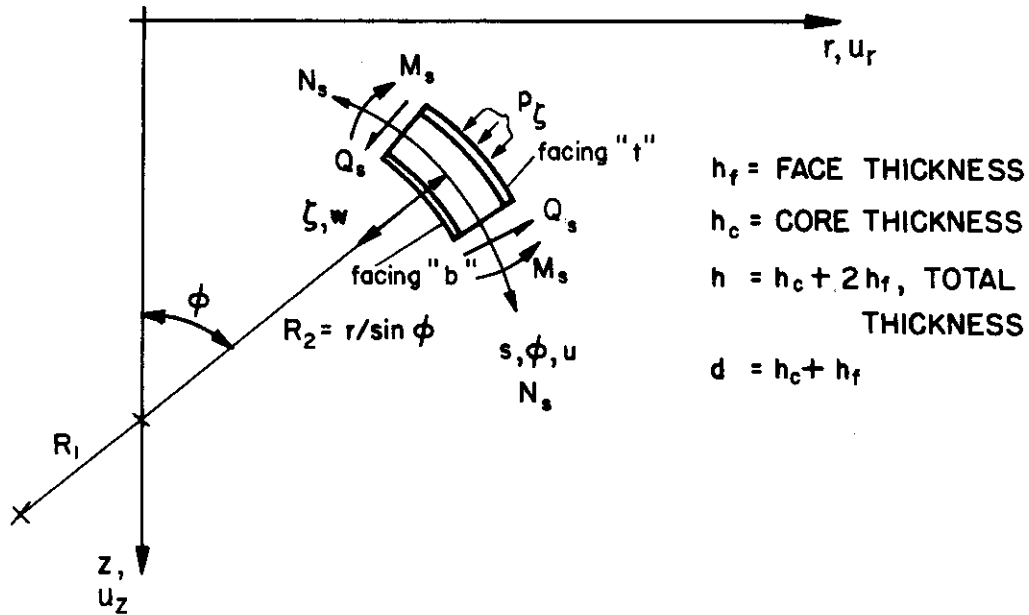

Figure 4. Axisymmetric Sandwich Shell Geometry

Where R_1 is the radius of meridional curvature. As in the beam analysis, this rotation can be considered to have two components. The pure shear contribution at any location along the meridian is the same as that given in Equation 2 for the beam:

$$\chi_s = \frac{dw_s}{ds} = \chi - \chi_b = \gamma_c h_c/d + \gamma_f h_f/d \quad (15)$$

If u and w are the displacements of the reference surface and if ζ_c and ζ_f are the thickness coordinates with origins at the respective middle surfaces of the layers, the kinematic assumptions result in the following expressions for the shell displacements due to axisymmetric loading:

$$\begin{aligned} u_c &= u - \zeta_c (\chi - \gamma_c) \\ u_f^{t,b} &= u - \zeta_f (\chi - \gamma_f) \pm \frac{d}{2} \chi \mp \frac{h_c}{2} \gamma_c \mp \frac{h_f}{2} \gamma_f \\ w_c &= w_f^t = w_f^b = w \end{aligned} \quad (16)$$

The shell strains may be written in the following form

$$\epsilon_{\beta k} = \epsilon_{\beta k}^o + \zeta_k \kappa_{\beta k} \quad (17)$$

where β represents either s or θ , and k either c or f . Therefore, applying the strain-displacement equations from the classic linear thin shell theory (Reference 19) to Equations 16, one obtains the strain-displacement equations for the sandwich shell

$$\begin{aligned} \epsilon_{sc}^o &= \frac{du}{ds} - \frac{w}{R_1} \\ \epsilon_{\theta c}^o &= \frac{1}{r} (u \cos \phi - w \sin \phi) \\ \kappa_{sc} &= -\frac{d\chi}{ds} + \frac{d\gamma_c}{ds} \\ \kappa_{\theta c} &= -\frac{\cos \phi}{r} (\chi - \gamma_c) \\ \epsilon_{sf}^{t,b} &= \frac{du}{ds} - \frac{w}{R_1} \pm \frac{d}{2} \frac{d\chi}{ds} \mp \frac{h_c}{2} \frac{d\gamma_c}{ds} \mp \frac{h_f}{2} \frac{d\gamma_f}{ds} \\ \epsilon_{sf}^{o,t,b} &= \frac{1}{r} (u \cos \phi - w \sin \phi) + \frac{\cos \phi}{r} \left(\frac{d}{2} \chi - \frac{h_c}{2} \gamma_c - \frac{h_f}{2} \gamma_f \right) \end{aligned}$$

$$\begin{aligned}
\kappa_{sf}^{t,b} &= -\frac{d\chi}{ds} + \frac{d\gamma_f}{ds} \\
\kappa_{\theta_f}^{t,b} &= -\frac{\cos\phi}{r} (\chi - \gamma_f) \\
\gamma_{s\zeta_c} &= \gamma_c \\
\gamma_{s\zeta_f}^{t,b} &= \gamma_f
\end{aligned} \tag{18}$$

However, in order to employ the substitute element, the strains must be expressed in terms of u_1 and u_2 , the displacements in local rectilinear coordinates. This can be accomplished by substituting the transformations of Equation 13 into Equations 14 and 18. The lengthy equations that result will not be given here (Reference 22).

In applying a stiffness analysis, the assumed displacement patterns are taken in the local rectilinear coordinate system and are expressed in terms of generalized coordinates. For a linear variation of shear strains and meridional displacement and a cubic variation of transverse displacement, the displacement model is given by

$$\begin{aligned}
u_1 &= \alpha_1 + \alpha_2 \xi \\
u_2 &= \alpha_3 + \alpha_4 \xi + \alpha_5 \xi^2 + \alpha_6 \xi^3 \\
\gamma_c &= \alpha_7 + \alpha_8 \xi \\
\gamma_f &= \alpha_9 + \alpha_{10} \xi
\end{aligned} \quad 0 \leq \xi \leq 1 \tag{19}$$

which may also be written

$$\begin{aligned}
\mathbf{u}(\xi) &= \mathbf{\Phi}(\xi) \mathbf{a} \\
5 \times 1 & \quad 5 \times 10 \quad 10 \times 1 \\
\mathbf{u}^T &= \langle u_1 \quad u_2 \quad \chi_b \quad \gamma \quad \gamma_f \rangle
\end{aligned} \tag{20}$$

By applying the strain-displacement equations to Equations 19 and 20, a result analogous to Equation 8 for the beam element is obtained

$$\boldsymbol{\epsilon} = \mathbf{B}(\xi) \mathbf{a} \tag{21}$$

$15 \times 1 \quad 15 \times 10 \quad 10 \times 1$

In addition, it is possible to construct the sparse matrices \mathbf{C} and $\mathbf{Z} \xi$ for the shell analogous to the matrices in Equations 6 and 9, respectively.

$$\begin{aligned}\sigma &= \mathbf{C} \epsilon \\ \epsilon &= \mathbf{Z}(\xi) \epsilon\end{aligned}\quad (22)$$

The constitutive matrix \mathbf{C} follows from the assumption of a state of generalized plane stress. The thickness-geometry matrix \mathbf{Z} is derived directly from Equation 17. Therefore, the element stiffness matrix in generalized coordinates may be obtained from the strain energy expression and is as follows:

$$\mathbf{k}_\alpha = 2\pi\ell \int_0^1 \mathbf{B}(\xi)^T \int_{-h/2}^{h/2} \mathbf{Z}(\xi)^T \mathbf{C} \mathbf{Z}(\xi) d\xi \mathbf{B}(\xi) \frac{r(\xi)}{\cos \beta} d\xi \quad (23)$$

10 x 10

The inner integral is readily evaluated in closed form. However, the integral with respect to ξ is more practically calculated by numerical means such as Gauss' integration formula.

The stiffness matrix must be transformed to a global coordinate system for the assembly process. In addition, interelement compatibility needs to be preserved only on the displacement parameters u , w , χ_b and γ . Hence, the element displacements in global coordinates are selected as follows:

$$\mathbf{r}^T = \langle u_i \quad w_i \quad \chi_{bi} \quad \gamma_i \quad u_j \quad w_j \quad \chi_{bj} \quad \gamma_j \quad \vdots \quad \gamma_{fi} \quad \gamma_{fj} \rangle$$

The transformation is given by

$$\begin{aligned}\mathbf{k} &= \mathbf{T}^T \mathbf{k}_\alpha \mathbf{T} \\ \mathbf{T} &= \mathbf{A}^{-1} \mathbf{T}\end{aligned}\quad (24)$$

10 x 10

Here \mathbf{A} is the transformation relating the local rectilinear coordinates to the generalized coordinates

$$\mathbf{q} = \begin{bmatrix} \Phi(0) \\ \Phi(1) \end{bmatrix} \alpha = \mathbf{A} \alpha \quad (25)$$

and \mathbf{T} is the simple point transformation connecting the local and global systems

$$\mathbf{q} = \mathbf{T} \mathbf{r} \quad (26)$$

Static condensation is employed to obtain the 8 x 8 stiffness used in the direct stiffness method. It should be noted that if the shell has discontinuities in the meridional slope, the curvilinear displacements u and w are not uniquely defined at these points. In this case, the translations in global coordinates can be taken in the rectilinear directions, i.e., u_r and u_z in Figure 4.

For rotational shells which are closed at the end, a special cap element is used to represent the closure. The stiffness for this element is obtained in basically the same manner as for the frustum element. However, "internal boundary conditions" are applied at the apex to reduce effectively the number of degrees of freedom (Reference 17). From the requirement of axisymmetry it is apparent that these conditions at the apex node are:

$$u_r = \chi = \gamma_c = \gamma_f = 0 \quad \text{at} \quad r = 0$$

In addition to the linear shear model, element stiffnesses have also been derived for a quadratic variation of shear. As for the beam, an internal node at $\xi = 1/2$ is utilized and static condensation enables reduction of the stiffness from 12 x 12 to 8 x 8.

SECTION IV

LUMPED MASSES FOR DYNAMIC ANALYSIS

The mass of the structure is concentrated at the nodal points so that the inertial properties can be represented by a diagonal mass matrix. Felippa (References 20 and 11) has demonstrated that this lumped mass procedure provides satisfactory fundamental frequencies and mode shapes with less computational effort than the consistent (or distributed) mass approach. For the same number of nodal points, the former method results in fewer equations for the eigenvalue problem. When meshes are arranged so there are the same number of eigenproblem equations for both techniques, Felippa's results indicate that the lumped mass approach produces the more accurate frequencies.

Rotatory inertia has been shown to be a more important factor in the vibration of sandwich plates (Reference 8) than in the dynamics of homogeneous plates. For translational displacements it is sufficient to idealize the lumped mass as a point on the reference surface (Figure 5a). However, for rotatory effects, the distribution of the mass through the depth of the beam must be maintained. This is especially true for sandwich structures where the outermost layers, the facings, may be much denser than the core. Hence, one can visualize the mass as being lumped along the material line originally normal to the reference surface, with no concentration of the mass across the depth (Figure 5b). In effect, this is the same as multiplying the mass moment of inertia of the cross section by the tributary area. It should be noted that the rotatory inertia is associated with the rotation of the normal to the reference surface, i.e., χ_b .

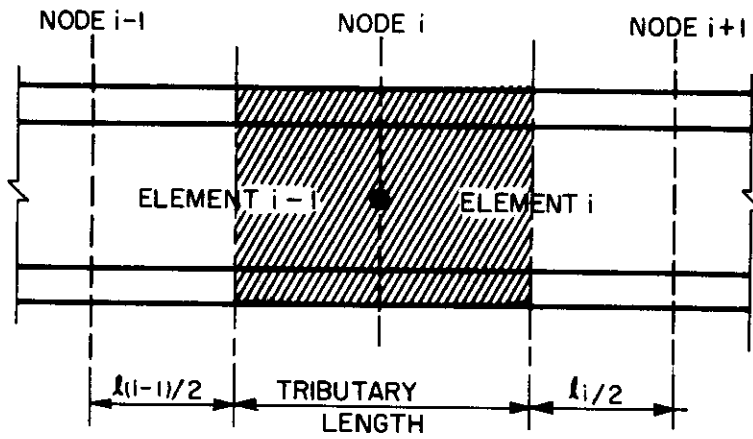

(a) LUMPED MASS FOR TRANSLATIONS

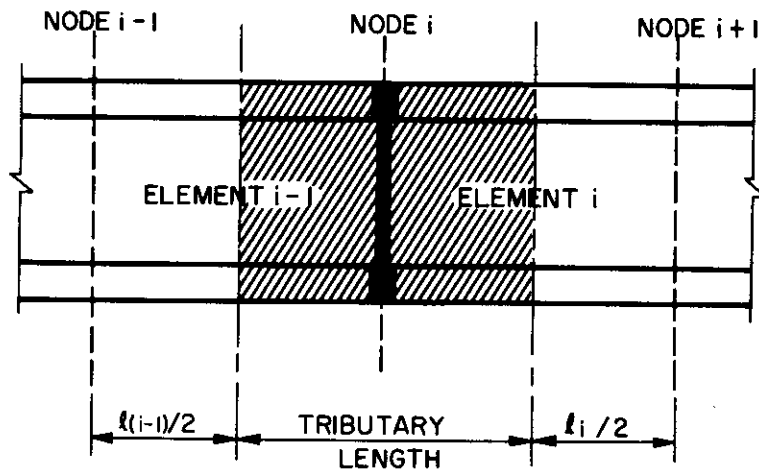

(b) LUMPED MASS FOR ROTATION

Figure 5. Arrangement of Lumped Masses

SECTION V

EXAMPLES

The above finite element formulation has been applied to various sandwich beam and shell problems and the results compared to solutions from other methods and sandwich theories.* A sampling of these problems is presented in this section to demonstrate the efficacy of the method. In general, the displacements, stress resultants and natural frequencies from the finite element method compare favorably to corresponding quantities obtained by established theories.

END-LOADED CANTILEVER BEAM

A cantilever sandwich beam of unit width with a unit load at the free end illustrates the effect of a constraint on the warping. The dimensions and properties are selected as follows:

$$\begin{aligned}
 h_c &= 0.5'' , h_f = 0.04'' , h = 0.58'' \\
 E_f &= 10^7 \text{ psi} , G_f = 4 \times 10^6 \text{ psi} , \lambda_f = 1 \\
 E_c &= 2 \times 10^4 \text{ psi} , G_c = 10^4 \text{ psi} , \lambda_c = 1 \\
 \text{span } L &= 10'' , \text{ load } P = 1.0 \text{ lb.}
 \end{aligned}$$

Evenly spaced meshes of 5 and 10 elements as well as uneven meshes are used for both linear shear strain (L elements) and quadratic shear strain (Q elements).

The displacement solution for 5-L elements is shown in Figure 6; the displacements from a 5-Q analysis fall about midway between the 5-L result and the solution of Reference 7. For all meshes and elements used, the overall stress resultants are correct to about five significant figures, so these results are not shown graphically. Of interest, however, is the distribution of shear force between the facings and core. The fraction of the shear assumed by the core is shown in Figure 7. The theory from Section 1.2 of Reference 6 does not take into account either the warping behavior or the bending stiffness of the facings; it assumes that all shear is taken by the core. The refinement to take into account the restraint on warping and the consequent flexure of the facings about their own middle surfaces is given

*For distributed loadings, consistent nodal loads are employed; e. g., for the beam, $\mathbf{Q} = \int_0^1 \Phi(\xi)^T \bar{\mathbf{p}}(\xi) d\xi$, where \mathbf{Q} are the nodal loads corresponding to displacements \mathbf{q} and $\bar{\mathbf{p}}$ are the specified loads.

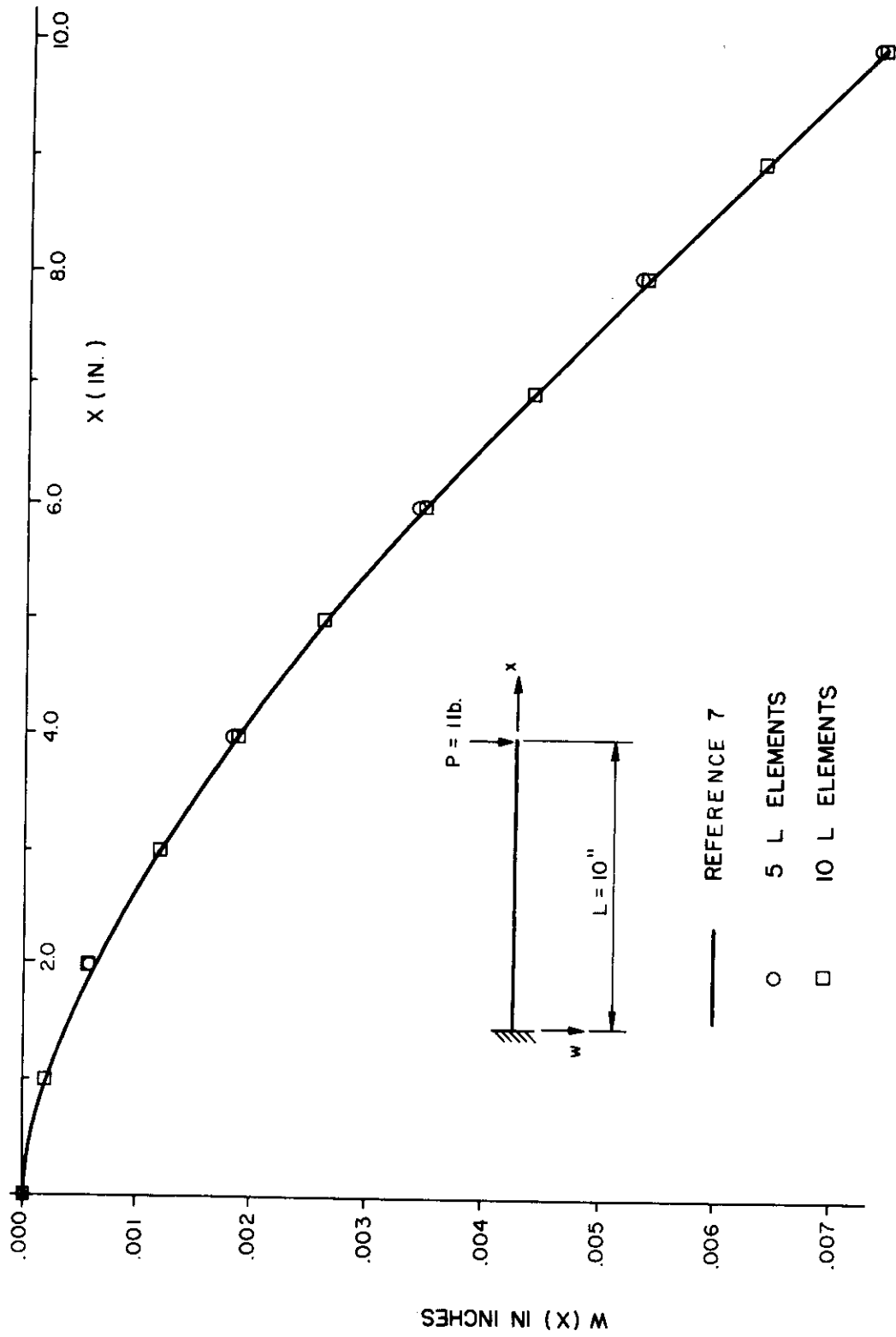

Figure 6. Deflection of a Cantilever Beam

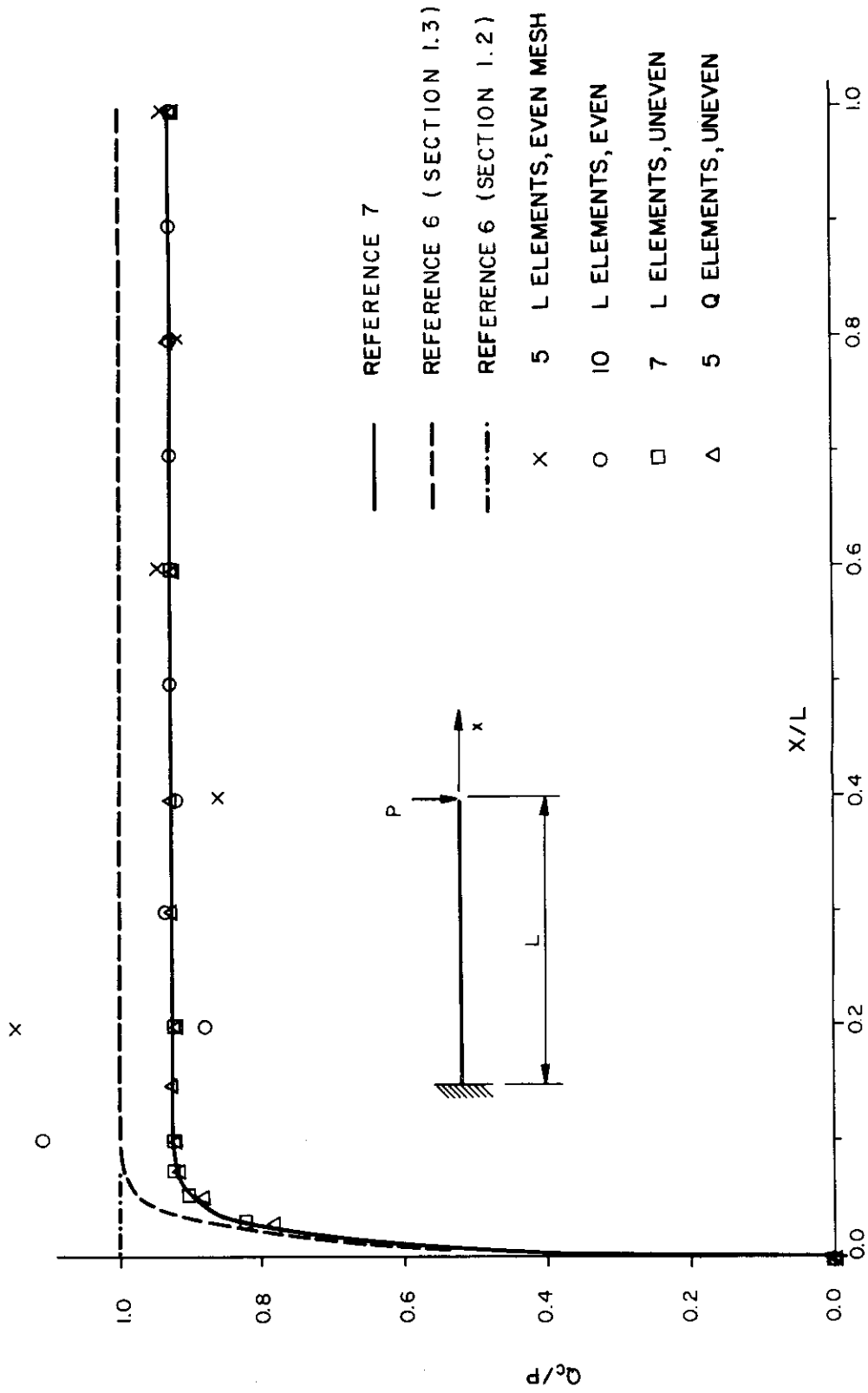

Figure 7. Shear Distribution Between Face and Core

in Section 1.3 of Reference 6. This formulation is due to van der Neut. Finally, Yu's theory (Reference 7) considers both the warping and the shearing of the facings and thus gives the distribution of shear among the various layers. Figure 7 demonstrates that with a proper mesh refinement, the finite element method gives an adequate representation of this phenomenon. Moreover, the quadratic shear-strain elements enable a satisfactory representation with fewer elements. At the support, the constraint against warping causes most of the shear to be carried by the facings.

Failures have been found to occur in the facings near fixed supports of aerospace sandwich structures. For this reason, the facing layers are usually doubled in thickness in these regions. The above results give an insight into the shear redistribution which necessitates the use of such doubler plates. In fact, the finite element method is suited for design of doubler plates since the computer program is readily modified to account for elements with differing face thicknesses. Hence it is possible to include these reinforcing layers in the analysis.

HEMISPHERICAL SHELL UNDER MEMBRANE LOAD

To check the effectiveness of the basic element and of the computer program for shells, the membrane states of both cylindrical and spherical shells have been investigated. Generally, the results are satisfactory in that both deflections and stress resultants agree with theoretical values. A typical example is presented here. The sandwich hemisphere has the following properties:

$$\begin{aligned}
 h_c &= 0.5", \quad h_f = 0.04" \\
 E_f &= 10^7 \text{ psi}, \quad \nu_f = 0.3, \quad G_f = 3.85 \times 10^6 \text{ psi}, \quad \lambda_f = 1.0 \\
 E_c &= 2.6 \times 10^4 \text{ psi}, \quad \nu_c = 0.3, \quad G_c = 10^4 \text{ psi}, \quad \lambda_c = 1.0 \\
 \text{radius } a &= 100", \quad \text{load } p_z = -1.0 \text{ psi}
 \end{aligned}$$

Three- and nine-element representations are used with both linear shear and quadratic shear. Results are essentially the same for the two shear-strain models, so only the solution using the less refined model is presented here.

When roller supports that restrict only the meridional displacements at the free edges are used, it is easily shown that the theoretical solution is

$$\begin{aligned}
 N_s = N_\theta &= 50 \text{ lb / in.} \\
 w &= -0.004305 \text{ in.}
 \end{aligned}$$

The finite element solution for three elements is shown in Figure 8. It is seen that the results agree very closely with the theoretical answers. The nine-element solution is even better, and is not shown since it does not differ significantly from the exact solution.

SHALLOW SPHERICAL CAP WITH PARTIAL DISTRIBUTED LOADING

The last static shell problem presented here is a simply supported shallow spherical cap subject to distributed loading over a portion of its surface. The closed-form solution for this problem in terms of Thomson functions has been given by Rossettos (Reference 21). He neglects the shearing of the faces and the bending and extension of the core, so the following properties are selected:

$$\begin{aligned} h_c &= 0.95'' , h_f = 0.025'' , h = 1'' \\ E_f &= 10^7 \text{ psi} , \nu_f = 0.3 , G_f = 10^{20} \text{ psi} , \lambda_f = 1 \\ E_c &= 0 , G_c = 10^5 \text{ psi} , \lambda_c = 1 \\ \text{radius } a &= 20'' , \text{ supported edge at } \phi = 15^\circ \end{aligned}$$

A uniform load of 1 psi is applied in the axial direction over that portion of the surface given by $0 \leq \phi \leq 3$ degrees.

The cap is analyzed using 5 and 10 linear-shear elements. Deflection results are presented in Figures 9 and 10, and stress resultants are plotted in Figures 11 through 13. In general, satisfactory results are obtained from the five-element representation. The small difference between the five- and ten-element results indicates that the finite element solution has effectively converged.

No examples are presented for shells which are not shallow because of the absence of published solutions with which to compare them, although the computer program developed is capable of solving such problems.

SIMPLY SUPPORTED CYLINDRICAL SHELL

One type of shell for which solutions for natural frequencies are readily available is the cylinder. Yu (Reference 9) has derived a three-branch frequency equation for an infinite

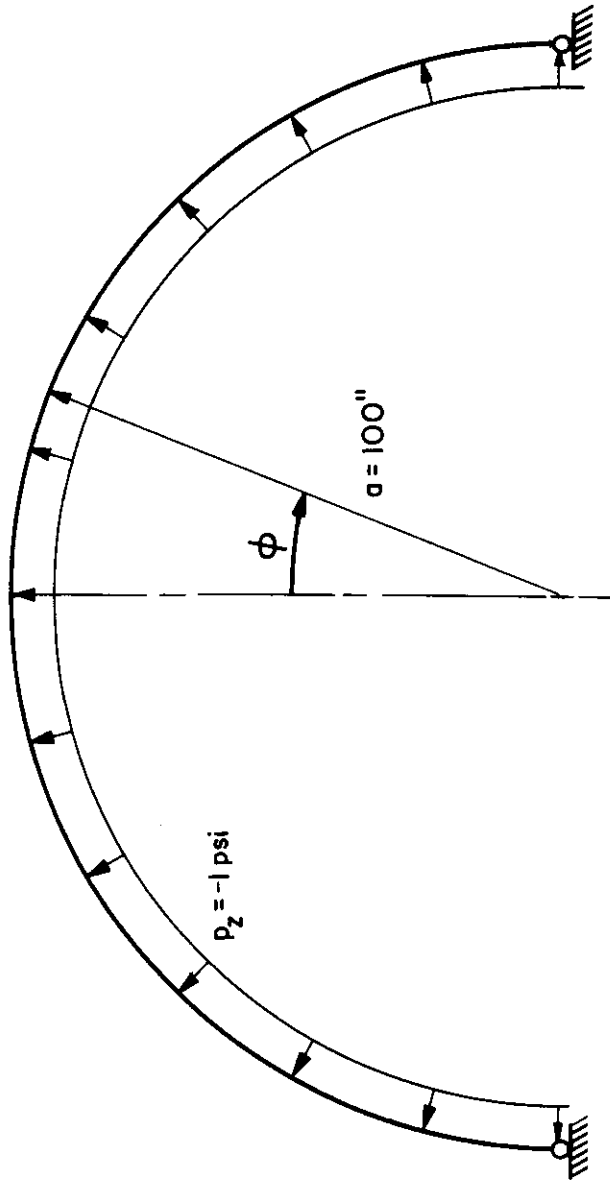

ϕ°	$-w \times 10^2 \text{ in.}$	$u \times 10^7 \text{ in.}$	$N_s \text{ lb/in.}$	$N_\theta \text{ lb/in.}$	$Q_s \text{ lb/in.}$	$M_s \text{ lb}$	$M_\theta \text{ lb}$
0	0.4306	0.0	49.993	49.993	0.0	0.0018	0.0018
30	0.4303	-0.46	49.987	49.981	0.0008	0.0020	0.0007
60	0.4303	0.69	49.978	49.974	0.0007	0.0022	0.0007
90	0.4302	0.0	50.023	49.981	0.0015	0.0011	0.0003

Figure 8. Hemispherical Shell Under Membrane Load (Three Elements)

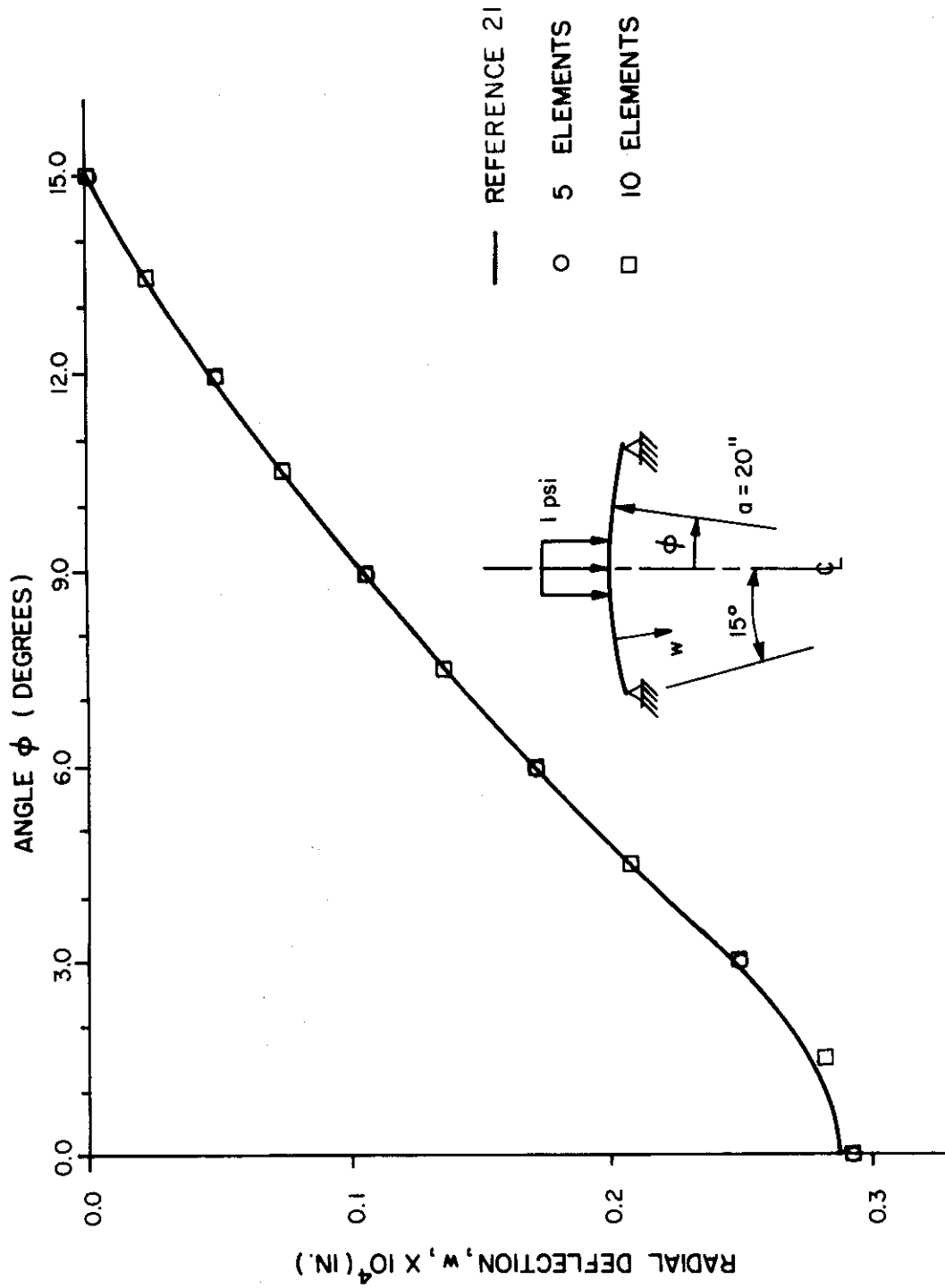

Figure 9. Radial Displacement of a Shallow Sphere

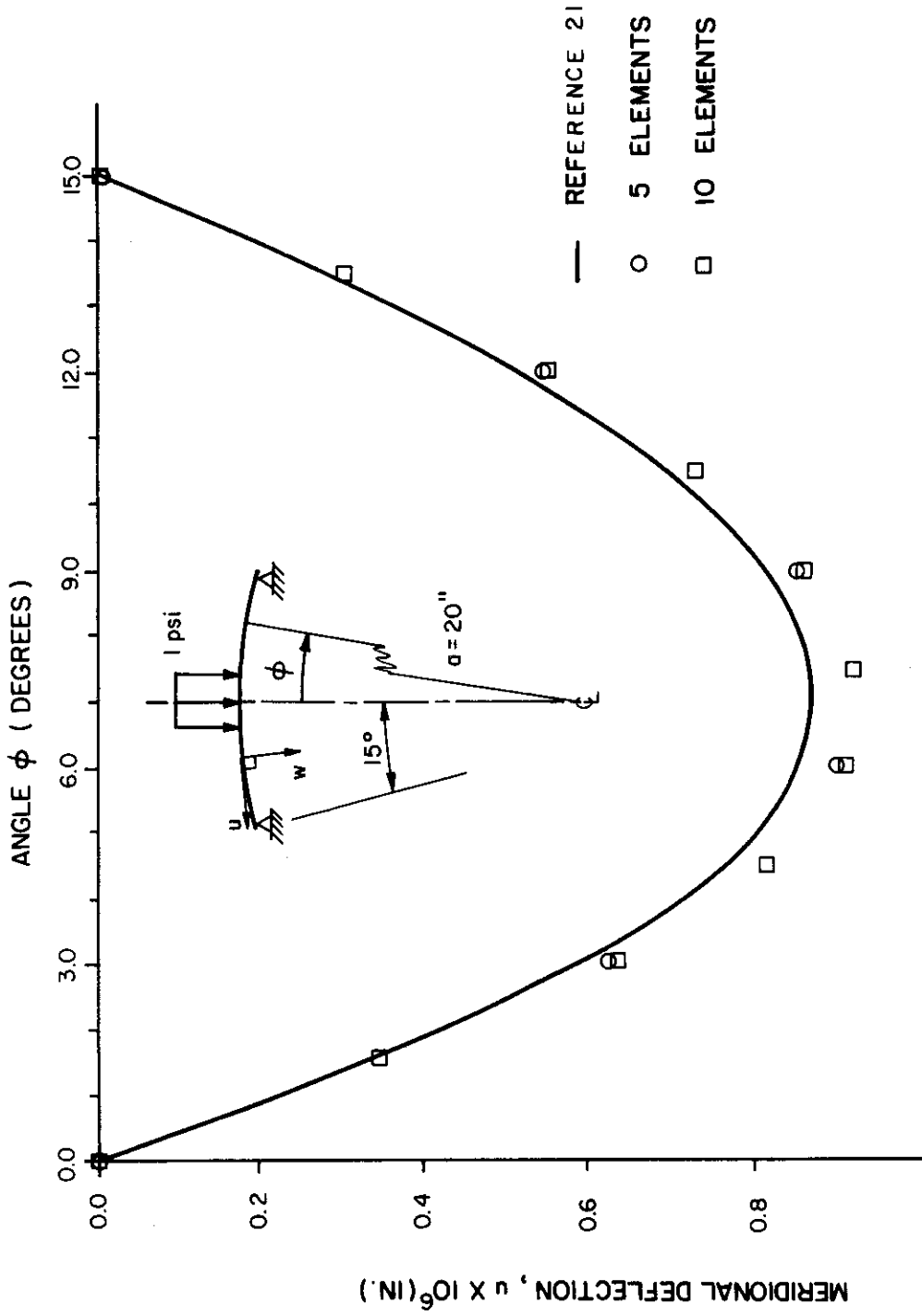

Figure 10. Meridional Displacement of a Shallow Sphere

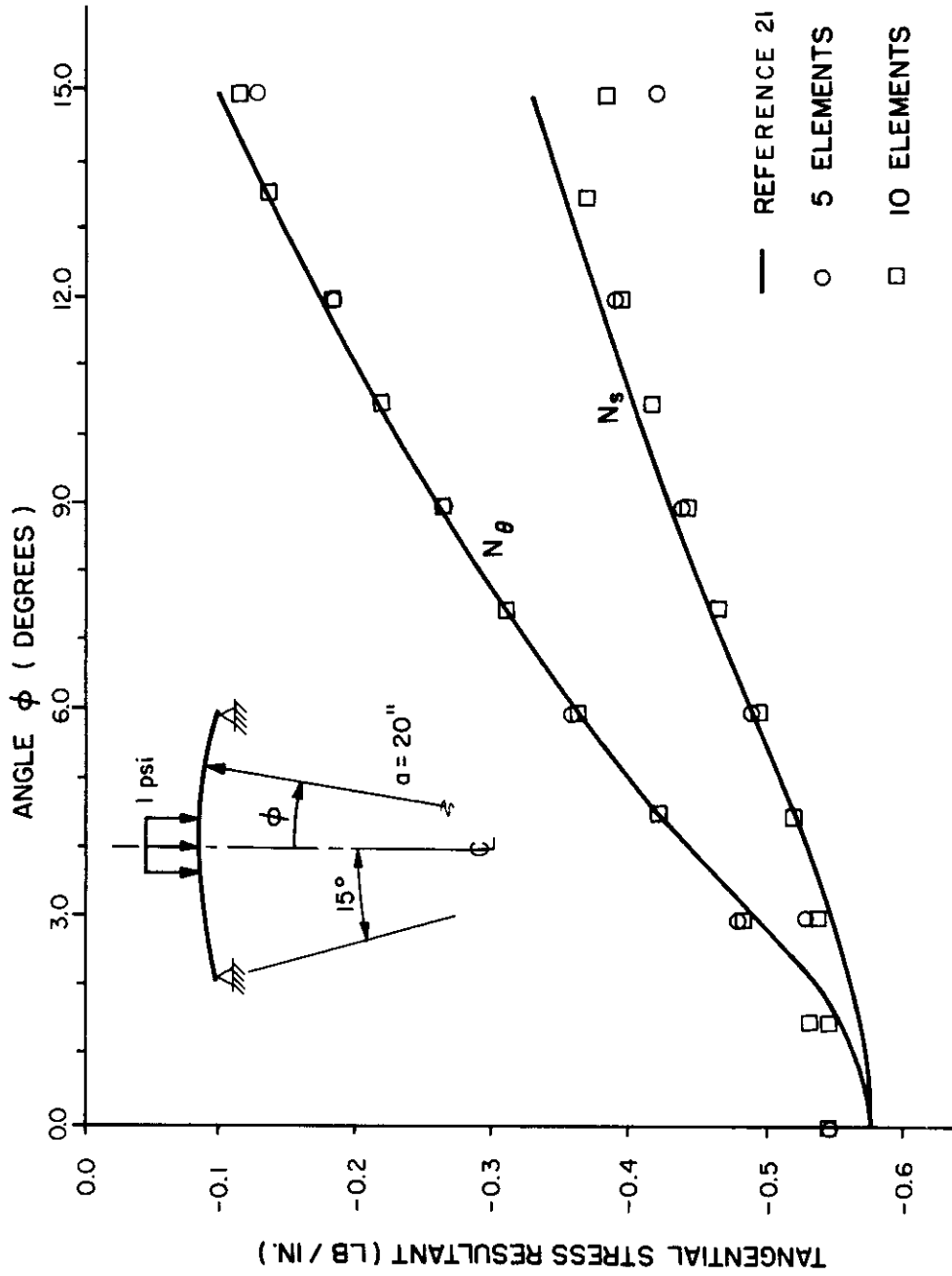

Figure 11. Tangential Stress Resultants of a Shallow Sphere

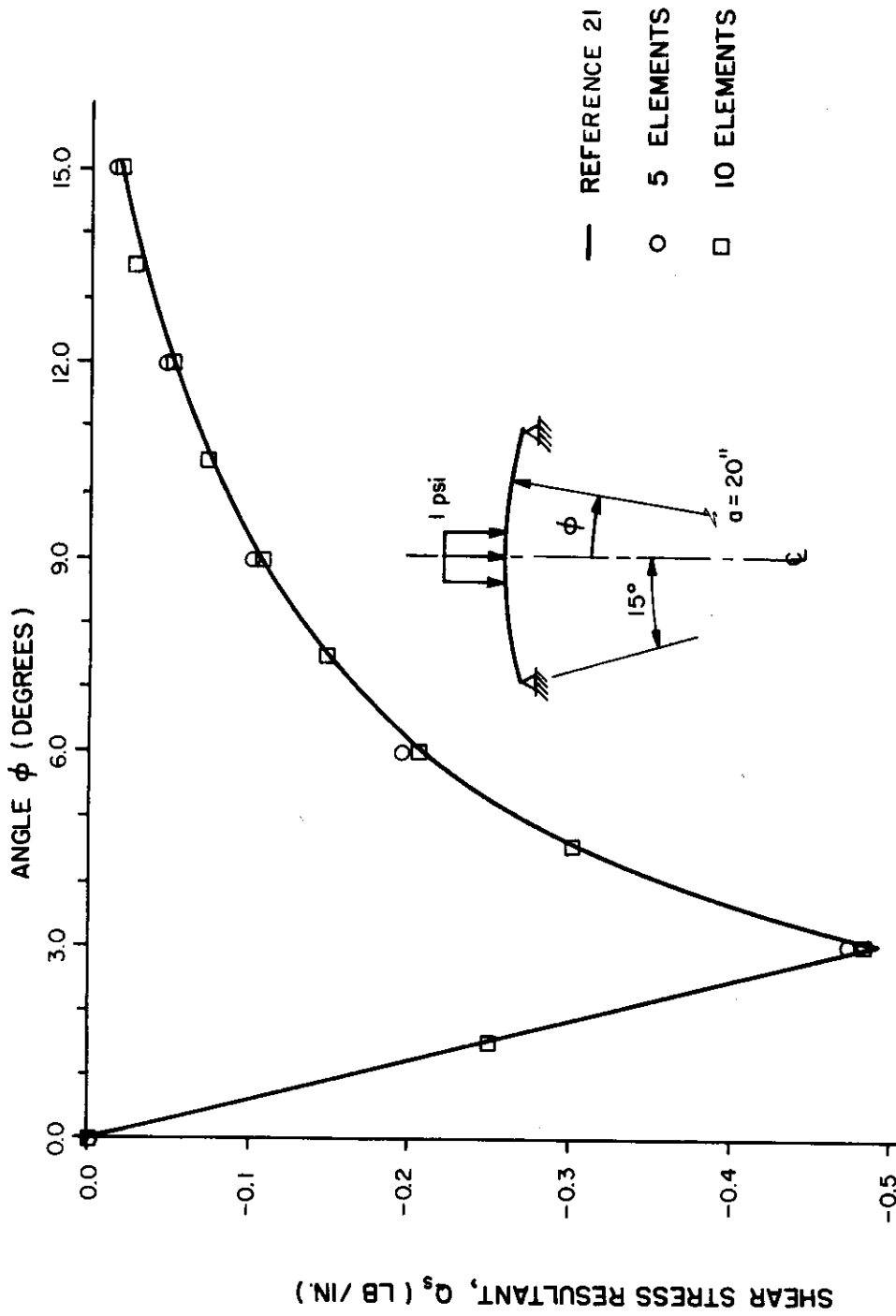

Figure 12. Shear Stress Resultant of a Shallow Sphere

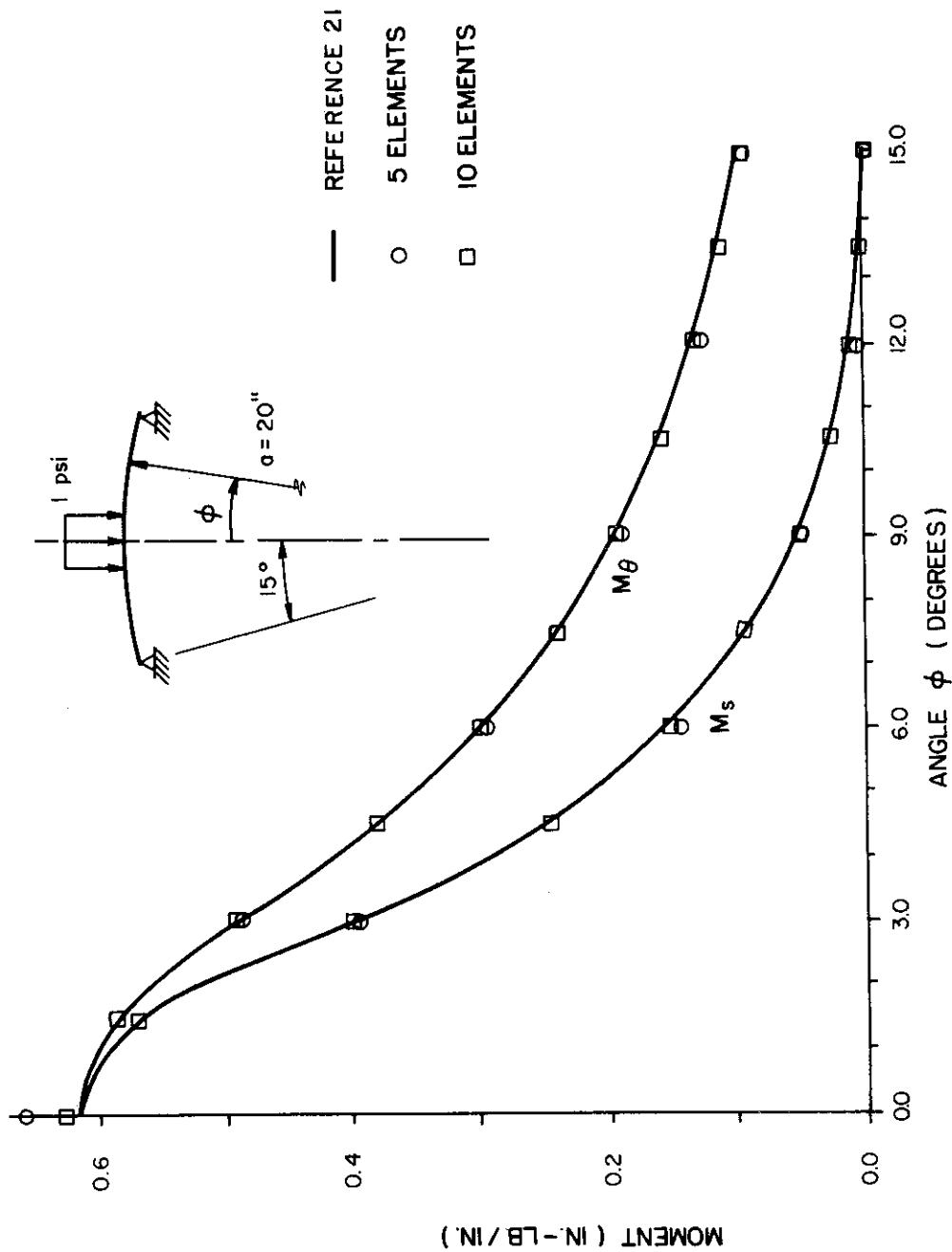

Figure 13. Moments of a Shallow Sphere

cylinder in an extension of his theory for sandwich plates (References 7 and 8). This equation is also applicable to a simply supported shell of finite length. A cylinder with the following properties is now analyzed.

$$\begin{aligned}
 h_c &= 0.5'' , h_f = 0.025'' , h = 0.55'' \\
 E_f &= 10^7 \text{ psi} , \nu_f = 0.3 , G_f = 3.85 \times 10^6 \text{ psi} , \lambda = 1 \\
 E_c &= 2.6 \times 10^4 \text{ psi} , \nu_c = 0.3 , G_c = 10^4 \text{ psi} , \lambda_c = 1 \\
 \rho_f &= 0.1 \text{ lb/in.}^3 , \rho_c = 0.005 \text{ lb/in.}^3 \\
 \text{radius, } a &= 20'' , \text{span, } L = 10''
 \end{aligned}$$

As in the preceding examples, these properties are typical of sandwich construction.

The natural frequencies computed by the finite element method are compared with solutions by Yu in Table I. Rotatory inertia is included in all cases and quadratic-shear elements are used. Many more frequencies than would be of practical interest are shown in the table in order to evaluate better the overall effectiveness of the finite element approach. It is noteworthy that the lowest frequencies of each of the three modes are approximated regardless of the number of elements used. The number of frequencies given by the finite element method for each mode depends on the number of degrees of freedom available of the type that are necessary to characterize the particular mode.

For shell structures there is usually more than one branch of the frequency equation that is of engineering importance. Careful study of the finite element mode shapes must be undertaken in order to identify the frequencies with the appropriate branch. This is especially true in preliminary analyses wherein the frequencies have not yet converged to a predictable pattern.

In the present example, simple supports which preclude translation in any direction are used. Hence the breathing mode or fundamental radial expansion mode is prevented. However, the example has been recomputed with supports that restrain only longitudinal displacements in order to obtain an estimate of the cut-off frequency of this radial mode. Yu's solution (Reference 9) for this frequency is 8520 radians/second. The finite element approximations for five, ten, and twenty elements are 8360, 8500 and 8520 radians/second, respectively.

TABLE I --NATURAL FREQUENCIES OF A SIMPLY SUPPORTED
SANDWICH CYLINDER (RAD./SEC.)

MODE	TYPE	Yu [9] Eq. 29	Finite Element Method		
			5 elems.	10 elems.	20 elems.
1	L1	8740	9040	9080	9080
2	L2	11900	11900	12100	12200
3	L3	16300	15500	16700	16800
4	L4	21000	18000	21500	21900
5	L5	25900		26000	27000
6	L6	30800		30000	32300
7	L7	35700		33400	37500
8	L8	40700		35900	42700
9	L9	45700		37400	47700
10	L10	50700			52700
11	R1	53600	52600	53300	53500
12	L11	55700			57400
13	L12	60700			61900
14	L13	65800			66000
15	TSCO	69800	71500	72800	73100
16	L14	70800			69800
17	L15	75800			73100
18	L16	80800			75900
19	L17	85900			78100
20	L18	90900			79700
21	TS1	92500	91200	94100	94900
22	L19	95900			80700
23	L20	101000			
24	L21	106000			
25	R2	107000	99800	105000	107000
32	TS2	140000	128000	138000	141000
37	R3	161000	137000	155000	159000
47	TS3	195000		187000	194000
	R4	214000		200000	211000
	TS4	252000		235000	249000
	R5	268000		241000	261000
	TS5	311000		278000	303000
	R6	321000		275000	309000
	TS7	370000			356000
	R7	375000			356000

L = Longitudinal, R = Radial, TS = Thickness Shear

SECTION VI

CONCLUSIONS

The finite element method has been extended to the refined analysis of multilayer beams and axisymmetric shells. In the theory employed no restriction is placed upon the ratios of the layer thicknesses and properties. The method is applicable to structures wherein shearing deformations are significant, including sandwich construction.

One of the features of the formulation developed herein is the capability of approximating the warping phenomenon. Hence, the distribution of the shearing force among the various layers can be determined. Another feature is the use of lumped rotatory inertia in the dynamic analyses. This type of inertia is a prerequisite for the inclusion of the thickness-shear modes of behavior, which are important for some soft-core sandwich structures. A third aspect of the present work is the possibility of neglecting either the shearing, extension or bending of any individual layer. By use of this capability, the effects of various approximations can be evaluated for different geometrical or material properties.

Generally, other available analysis techniques can only be applied to sandwich structures with the simplest configurations. Hence there is a great potential for the application of the finite element method to the solution of sandwiches of arbitrary shape.

Acknowledgments

During the early stages of this research, the first author was sponsored by a National Science Foundation Fellowship. Thereafter, support for the investigations was provided by the National Aeronautics and Space Administration under Research Grant NsG 274 S-3. Computer facilities and time were provided by the Computer Center of the University of California, Berkeley. All of this support is gratefully acknowledged.

This paper is based on a part of a dissertation presented to the University of California, Berkeley, by the first author in partial fulfillment of the requirements of the degree of Doctor of Philosophy.

SECTION VII

REFERENCES

1. Dong, S. B., Matthiesen, R. B., Pister, K. S. and Taylor, R. L., "Analysis of Structural Laminates," USAF Aeronautical Research Laboratory Report 74, Wright-Patterson AFB, Ohio, September, 1961.
2. Radkowski, P. P., "Thermal Stress Analysis of Orthotropic Thin Multilayered Shells of Revolution," AIAA Structures Meeting, April, 1963.
3. Dong, S. B., "Analysis of Laminated Shells of Revolution," J. Eng. Mechs. Div., Proc. ASCE, Vol. 92, No. EM6, December, 1966, pp. 135-155.
4. Foss, J. I., "For the space age: A Bibliography of Sandwich Plates and Shells," Douglas Report SM-42883, December, 1962, 98 pp.
5. Habip, L. M., "A Survey of Modern Developments in the Analysis of Sandwich Structures," App. Mech. Reviews, Vol. 18, No. 2, February, 1965, pp. 93-98.
6. Plantema, F. J., Sandwich Construction: The Bending and Buckling of Sandwich Beams, Plates, and Shells, John Wiley & Sons, New York, 1966, 246 pp.
7. Yu, Y. Y., "A New Theory of Elastic Sandwich Plates -- One-Dimensional Case," J. App. Mech., Vol. 26, No. 3, September 1959, pp. 415-421.
8. Yu, Y. Y., "Flexural Vibrations of Elastic Sandwich Plates," J. Aero. Sci., Vol. 27, No. 4, April, 1960, pp. 272-283.
9. Yu, Y. Y., "Vibrations of Elastic Sandwich Cylindrical Shells," J. App. Mech., Vol. 27, No. 4, December, 1960, pp. 653-662.
10. Przemieniecki, J. S., The Theory of Matrix Structural Analysis, McGraw-Hill, New York, 1968, 468 pp.
11. Felippa, C. A. and Clough, R. W., "The Finite Element Method in Solid Mechanics," Symposium on Numerical Solutions of Field Problems in Continuum Mechanics, American Mathematical Society, Durham, N. C., April 5-6, 1968.
12. Popov, E. P., Penzien, J., and Lu, Z. A., "Finite Element Solution for Axisymmetric Shells," J. of Eng. Mechs. Div., Proc. ASCE, Vol. 90, No. EM5, Oct. 1964, pp. 119-145.
13. Grafton, P. E. and Strome, D. R., "Analysis of Axisymmetrical Shells by the Direct Stiffness Method," AIAA J., Vol. 1, No. 10, October, 1963, pp. 2342-2347.
14. Percy, J. H., Pian, T. H. H., Klein, S. and Navaratna, D. R., "Application of Matrix Displacement Method to Linear Elastic Analysis of Shells of Revolution," AIAA J., Vol. 3, No. 11, November, 1965, pp. 2138-2145.
15. Jones, R. E. and Strome, D. R., "Direct Stiffness Method Analysis of Shells of Revolution Utilizing Curved Elements," AIAA J., Vol. 4, No. 9, September, 1966, 1519-1525.

REFERENCES (CONT)

16. Striklin, J. A., Navaratna, D. R. and Pian, T. H. H., "Improvements on the Analysis of Shells of Revolution by the Matrix Displacement Method," AIAA J. Vol. 4, No. 11, November, 1966, pp. 2069-2072.
17. Khojasteh-Bakht, M., "Analysis of Elastic-Plastic Shells of Revolution Under Axisymmetric Loading by the Finite Element Method," Ph.D. Dissertation, Department of Civil Engineering, University of California, Berkeley, California, 1967 (also published as SESM Report 67-8).
18. Irons, B. H. R. and Draper, K. J., "Inadequacy of Nodal Connections in a Stiffness Solution for Plate Bending," AIAA, J., Vol. 3, No. 5, May, 1965, p. 961.
19. Novozhilov, V. V., The Theory of Thin Elastic Shells, translated from the Russian by P. G. Lowe, edited by J. R. M. Radok, P. Noordhoff Ltd., Groningen, The Netherlands, 1959.
20. Felippa, C. A. "Analysis of Plate Bending Problems by the Finite Element Method," SESM Report 68-4, Department of Civil Engineering, University of California, Berkeley, California, 1968.
21. Rossettos, J. N., "Deflection of Shallow Spherical Sandwich Shell under Local Loading," U. S. NASA TN D-3855, February, 1967, 45 pp.
22. Abel, J. F., "Static and Dynamic Analysis of Sandwich Shells with Viscoelastic Damping," Ph.D. Dissertation, Department of Civil Engineering, University of California, Berkeley, California, August, 1968.
23. Ambartsumian, S. A., Theory of Anisotropic Plates, Nauka, Moscow, 1967, 266 pp.

