

AD _____

Award Number: DAMD17-03-1-0698

TITLE: The Effects of Fatty Acids on Retinoid Signaling in Human Mammary Epithelial Cells and Breast Cancer Cells

PRINCIPAL INVESTIGATOR: Simne Langton, Ph.D.
Lorraine J. Gudas, Ph.D.

CONTRACTING ORGANIZATION: Cornell University
Ithaca, NY 14853

REPORT DATE: September 2005

TYPE OF REPORT: Annual Summary

PREPARED FOR: U.S. Army Medical Research and Materiel Command
Fort Detrick, Maryland 21702-5012

DISTRIBUTION STATEMENT: Approved for Public Release;
Distribution Unlimited

The views, opinions and/or findings contained in this report are those of the author(s) and should not be construed as an official Department of the Army position, policy or decision unless so designated by other documentation.

20060508042

REPORT DOCUMENTATION PAGE

Form Approved
OMB No. 0704-0188

Public reporting burden for this collection of information is estimated to average 1 hour per response, including the time for reviewing instructions, searching existing data sources, gathering and maintaining the data needed, and completing and reviewing this collection of information. Send comments regarding this burden estimate or any other aspect of this collection of information, including suggestions for reducing this burden to Department of Defense, Washington Headquarters Services, Directorate for Information Operations and Reports (0704-0188), 1215 Jefferson Davis Highway, Suite 1204, Arlington, VA 22202-4302. Respondents should be aware that notwithstanding any other provision of law, no person shall be subject to any penalty for failing to comply with a collection of information if it does not display a currently valid OMB control number. **PLEASE DO NOT RETURN YOUR FORM TO THE ABOVE ADDRESS.**

1. REPORT DATE (DD-MM-YYYY) 01-09-2005		2. REPORT TYPE Annual Summary		3. DATES COVERED (From - To) 1 Sept 04 – 31 Aug 05	
4. TITLE AND SUBTITLE The Effects of Fatty Acids on Retinoid Signaling in Human Mammary Epithelial Cells and Breast Cancer Cells.				5a. CONTRACT NUMBER	
				5b. GRANT NUMBER DAMD17-03-1-0698	
				5c. PROGRAM ELEMENT NUMBER	
6. AUTHOR(S) Simne Langton, Ph.D. Lorraine J. Gudas, Ph.D. E-Mail: Sin2002@med.cornell.edu				5d. PROJECT NUMBER	
				5e. TASK NUMBER	
				5f. WORK UNIT NUMBER	
7. PERFORMING ORGANIZATION NAME(S) AND ADDRESS(ES) Cornell University New York, NY 10021				8. PERFORMING ORGANIZATION REPORT NUMBER	
9. SPONSORING / MONITORING AGENCY NAME(S) AND ADDRESS(ES) U.S. Army Medical Research and Materiel Command Fort Detrick, Maryland 21702-5012				10. SPONSOR/MONITOR'S ACRONYM(S)	
				11. SPONSOR/MONITOR'S REPORT NUMBER(S)	
12. DISTRIBUTION / AVAILABILITY STATEMENT Approved for Public Release; Distribution Unlimited					
13. SUPPLEMENTARY NOTES					
14. ABSTRACT Retinoic acid (RA) regulates the proliferation of a wide variety of cell types through the action of retinoic acid receptors. Phytanic acid (PA) and docosahexaenoic acid (DHA) are diet-derived fatty acids that bind to retinoid X receptors (RXR). Therefore, we hypothesized that inhibitory effects on cell proliferation may be enhanced by the addition of PA and DHA to RA-treated cells. We demonstrate that 1) the combination of PA or DHA with RA resulted in enhanced growth arrest of estrogen receptor positive human breast cancer (HBC) cells; 2) PA and DHA induced growth arrest of estrogen receptor negative HBC cells; 3) synthetic RXR agonists induced growth inhibitory effects similar to PA and DHA in HBC cells; and 4) PA enhanced RA-induced expression of CYP26 mRNA in HBC cells and in murine embryonic stem cells. Our data indicate that PA and DHA may be useful adjuvant agents when retinoids are used to inhibit cell proliferation and/or to induce cell differentiation. Deciphering the effects of diet-derived RXR agonists may lead to new therapeutic and experimental uses of these agents in combination with retinoids.					
15. SUBJECT TERMS breast cancer, retinoic acid receptor, retinoid x receptor, Docosahexaenoic acid, phytanic acid					
16. SECURITY CLASSIFICATION OF:			17. LIMITATION OF ABSTRACT	18. NUMBER OF PAGES	19a. NAME OF RESPONSIBLE PERSON
a. REPORT	b. ABSTRACT	c. THIS PAGE			19b. TELEPHONE NUMBER (include area code)
U	U	U	UU	14	

Table of Contents

Cover.....	1
SF 298.....	2
Table of Contents.....	3
Introduction.....	4
Body.....	6
Key Research Accomplishments.....	12
Reportable Outcomes.....	12
Conclusions.....	12
References.....	13

INTRODUCTION

Retinoids are the natural and synthetic derivatives of vitamin A (retinol), and function as steroid-hormone-like molecules in regulating diverse biological processes such as cellular proliferation, differentiation, and apoptosis (1). Retinoid actions are mediated by the retinoic acid receptors (RARs) and retinoid X receptors (RXRs) (2, 3). RARs and RXRs are ligand-activated transcription factors that bind as RXR:RAR heterodimers to retinoic acid response elements (RAREs), specific DNA sequences in target gene promoters (2, 3). Ligand binding causes the dissociation of co-repressor proteins and promotes association of co-activators, resulting in activation of gene transcription (2, 3). Retinoic acid as well as its polar metabolites, such as 4-oxo-RA and 4-OH-RA, have been shown to be biologically active and act as ligands for RARs (4).

The enzyme responsible for the metabolism of RA into the bioactive polar metabolites, 4-oxoRA and 4-OH-RA, is CYP26, also known as P450RAI (5). CYP26 expression is induced by RA, and in the previous annual summary, data was given that showed RA-induced CYP26 expression was enhanced by the addition of the fatty acids, phytanic acid (PA) or docosahexaenoic acid (DHA) in some breast cancer cell lines and in a murine embryonic stem (ES) cell line. We had also looked at cell proliferation upon treatment with RA or PA or DHA, or a combination of the retinoid with the fatty acid. Consistent with previous studies, RA growth inhibited ER-positive breast cancer cell lines but not ER-negative breast cancer cell lines. The addition of PA or DHA enhanced this inhibition slightly. Also, the fatty acids alone had growth inhibitory effects on some of the breast cancer cell lines, making it difficult to conclude how the fatty acids affect retinoid signaling in breast cancer in general. To determine the mechanism of a modest

enhancement would be difficult because the breast cancer cell lines used in the study are independent cell lines that have different degrees of differentiation, aggressiveness, estrogen receptor expression, and tumor origin. In addition, the different cell lines metabolize RA differently. In one study, RA-sensitive breast cancer cell lines were found to metabolize RA at a high rate whereas RA-resistant breast cancer cell lines metabolized RA at a much lower rate (6). Therefore, the metabolism of RA does affect how cells will respond to RA treatment. However, the metabolism of RA by CYP26 and the resulting effects on retinoid signaling is not clear.

To study how retinoid signaling is affected by metabolism of RA into bioactive polar metabolites, via the activation of CYP26, we generated a CYP26-knock out (-/-) ES cell line. The CYP26-/- cell line allows us to learn how retinoid signaling is affected in the absence of this metabolic enzyme, and thus the absence of any polar metabolites of retinoic acid. The CYP26-/- cell line is initially being characterized by growth curves, dose response experiments, and HPLC analysis. In the future, gene expression studies will also be done. Results can be directly compared to the parental cell line, which only differs by the expression of CYP26.

BODY

Generation of the CYP26 $-/-$ ES cell line.

The CYP26 targeting construct contains the CYP26 genomic sequence with LoxP sites subcloned after exon 1 and after exon 7 (Figure 1A). The construct was a kind gift from Dr. Martin Petkovich. The construct was electroporated into a wild-type (WT) ES cell line, AB1. Since the construct contained a Neo cassette, cells were grown in the presence of the antibiotic G418. Resistant clones were isolated for Southern analysis, and clones that had successfully recombined with the construct were grown in even higher concentrations of G418 to select for cells that have undergone another round of recombination. These resistant clones were isolated for Southern analysis, and clones that had only the CYP26 targeting construct and not the WT CYP26 genomic sequence were then electroporated with a Cre-recombinase plasmid (Figure 1B). Cells were grown in medium without antibiotic and clones were isolated and analyzed by Southern and Northern. Six positive clones were found to lack CYP26 exons 2-6, and are named CYP26 $-/-$ (Figure 1C and D).

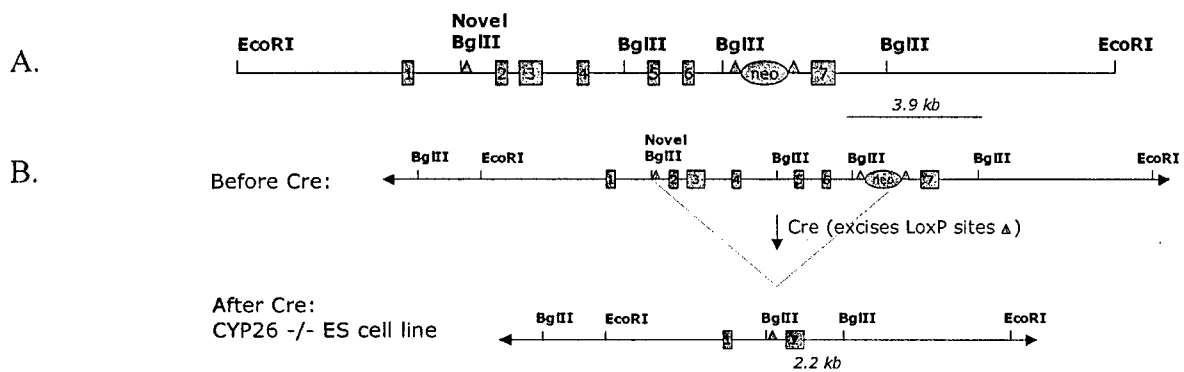

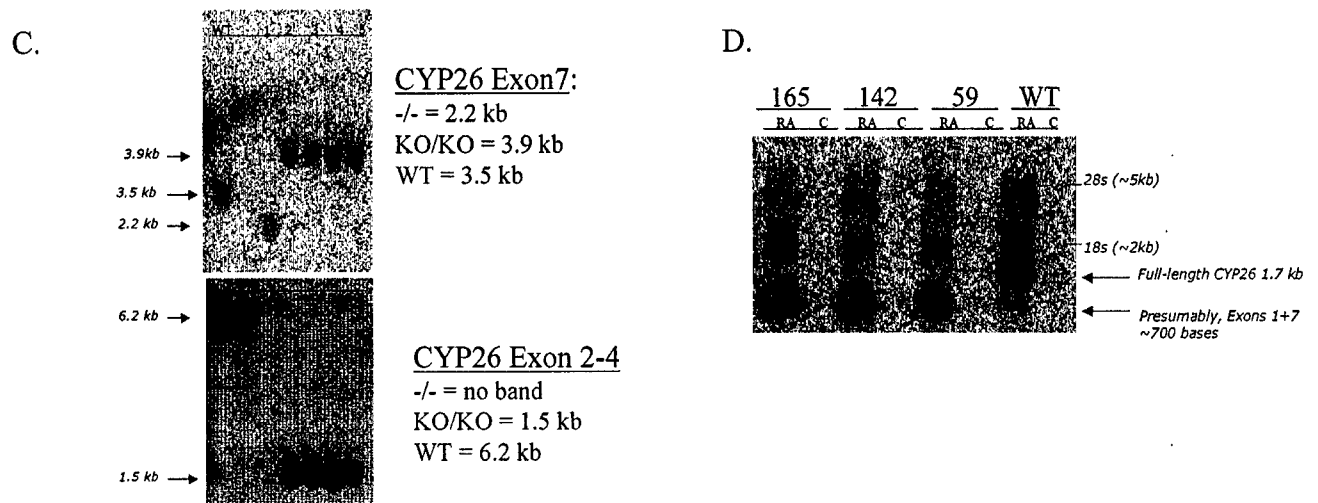

Figure 1. Targeted excision of exons 2-6 of the CYP26 gene by using Cre-*loxP* system. (A) The targeting construct used to generate the CYP26 knock out is shown here. The construct contains the CYP26 genomic sequence, including its 7 exons, flanked by 2.8 kb of 5' homology and 4.3 kb of 3' homology. The neo cassette, which confers antibiotic resistance, was subcloned inside intron 6 between exon 6 and 7. It is flanked by *loxP* sites on either side. Another *loxP* site was cloned inside intron 1 between exons 1 and 2. (B) After recombination of the construct into both alleles, Cre recombinase was introduced to excise at the *loxP* sites, resulting in the removal of exons 2-6. (C) Southern analysis was used to determine which clones had successfully excised out exons 2-6. Briefly, genomic DNA was isolated, digested with BglIII enzyme, and electrophoresed on an agarose gel. The gel was transferred onto a nylon blot and probed with various radiolabeled DNA. This blot is an example showing lane 1 as a positive clone (-/-). The top Southern was probed with CYP26 exon 7 and the bottom Southern was probed with CYP26 exon 2-4. (D) A representative Northern analysis blot showing the induction of CYP26 after treatment with RA. Three of the six positive clones, #165, #142, #59, are shown in this Northern analysis where these three CYP26^{-/-} cell lines and the WT cell line were treated with 1 μ M RA or control vehicle. RNA was isolated, electrophoresed on an agarose gel, transferred onto a nylon blot, and probed with radiolabeled CYP26 exon 7 DNA. Only the WT cells express the full length CYP26 after RA treatment. The CYP26^{-/-} clones express a ~700 basepair transcript which is most likely to be exon 1 and 7.

CYP26^{-/-} ES cells grow much faster than WT ES cells.

To characterize cell proliferation of the CYP26^{-/-} ES cells, two independent CYP26^{-/-} ES cell lines, #59 and #142, and the WT cell line were analyzed by growth

curve assays. After 96 hours, both CYP26^{-/-} ES cell lines grew measurably faster than the WT ES cells (Figure 2A). By 168 hours, the CYP26^{-/-} cell lines had proliferated significantly more than the WT cell line ($P < 0.001$). Two-way ANOVA from Prism Software was used to statistically analyze the data. Both CYP26^{-/-} cell lines showed similar growth characteristics. All cell lines did not grow well in the absence of LIF, and by 168 hours, many floating dead cells can be seen in the wells.

(A)

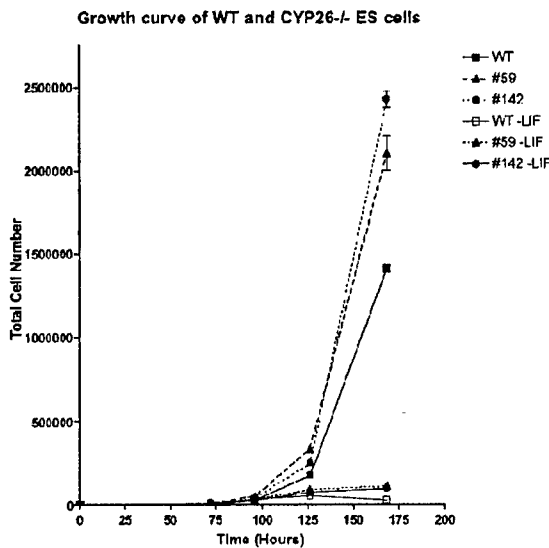

Figure 2. Cell proliferation of WT and CYP26^{-/-} #59 and #142 ES cells over time in the presence or absence of LIF. (A) The three cell lines were seeded at a density of 1000 cells per well in 6-well plates either in the presence or absence of leukemia inhibitory factor, LIF. Cells were counted at 72, 96, 125, and 168 hours after plating.

CYP26^{-/-} ES cells and WT ES cells are growth inhibited by RA similarly.

Since the role of CYP26 is to metabolize RA into polar metabolites, we wanted to study the sensitivity of the CYP26^{-/-} ES cells to RA treatment. We treated both WT and CYP26^{-/-} ES cells to a range of RA concentrations, from 1 nM to 1 μ M, in the presence or absence of LIF. After 72 hours of drug treatment, cells were counted. WT and

CYP26^{-/-} ES cells were growth inhibited by all concentrations of RA used, and they had similar sensitivity to growth inhibition by RA (Figure 3A and B). Therefore, the CYP26^{-/-} ES cells are not more sensitive to RA-induced growth inhibition. The absence of LIF drastically reduced cell proliferation in both WT and CYP26^{-/-} ES cells.

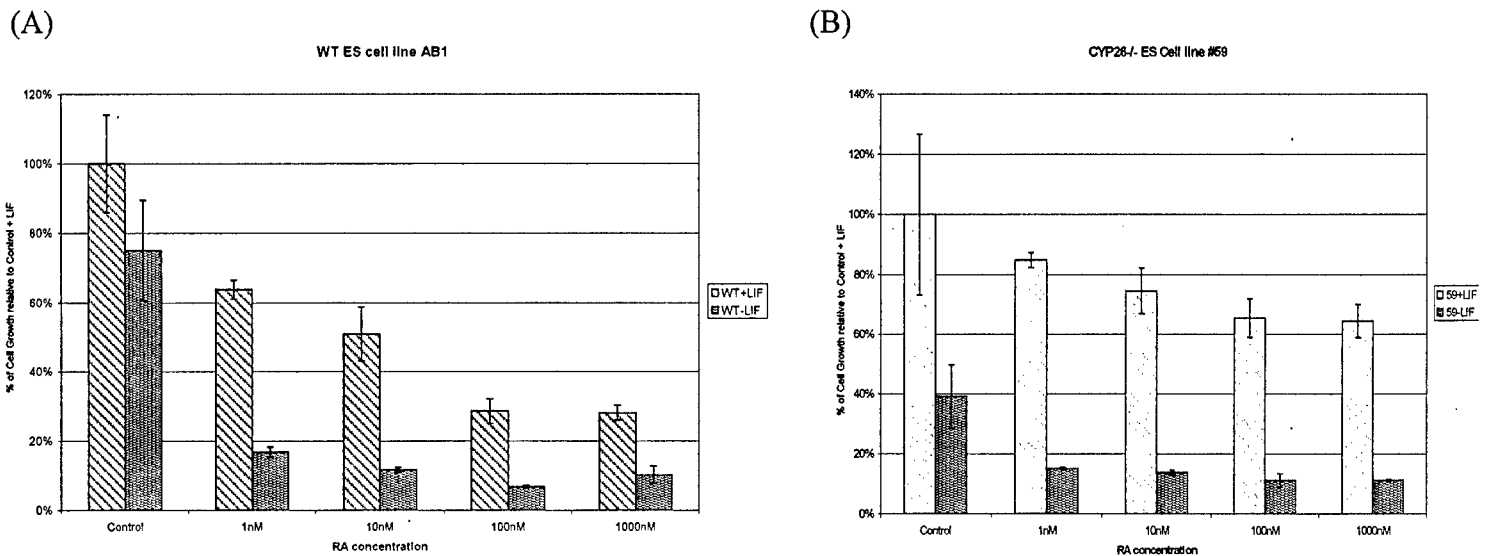

Figure 3. RA inhibits growth of WT and CYP26^{-/-} ES cells in a dose dependent-manner. (A) WT and (B) CYP26^{-/-} ES cells were seeded at a density of 10000 cells per well in 12-well plates in the presence or absence of LIF. One day after plating, the medium was replaced with medium containing control vehicle (ethanol) or various concentrations of RA. 48 hours later, the medium was changed again and replaced with fresh medium containing control vehicle or RA. After a total of 72 hours drug treatment, cells were trypsinized and counted. This experiment was repeated five times. The cell numbers were averaged and the condition "Control +LIF" was chosen as 100% growth. The drug treatments were then normalized to "Control +LIF" to determine their percentage growth.

CYP26^{-/-} ES cells do not metabolize RA and have high levels of intracellular RA.

To study the metabolism of RA by the CYP26^{-/-} ES cells, radiolabeled RA was used to treat WT and CYP26^{-/-} ES cells and then the medium and the cell extracts were analyzed by HPLC. Two independent CYP26^{-/-} ES cell lines were used to confirm the data. Both CYP26^{-/-} ES cell lines did not have any detectable polar metabolites as compared to the WT ES cells confirming that CYP26 is not functional in the CYP26^{-/-}

cell lines (Figure 4A). In the WT ES cells, RA was rapidly metabolized into polar metabolites and by 8 hours radiolabeled RA treatment, very little detectable RA was left in the cells or in the medium (data not shown). In other words, most of the RA had been metabolized into polar metabolites. On the other hand, the CYP26^{-/-} ES cells did not metabolize RA. After 8 hours radiolabeled RA treatment, most of the RA from the medium was now inside the cell, resulting in a high intracellular level of RA, which was not seen in the WT ES cells.

Since using radiolabeled RA in the HPLC analysis only allowed us to see what was happening to the radioactive retinoids, we decided to look at total retinoids in the cells by treating with non-radioactive RA and then performing HPLC. Similar results were obtained by this method. After 48 hours treatment with non-radioactive RA, WT ES cells had no detectable RA in the cells, but the CYP26^{-/-} ES cells still had high amounts of RA inside the cells (Figure 4B). For both WT and CYP26^{-/-} ES cells, not much RA was detected in the medium (data not shown).

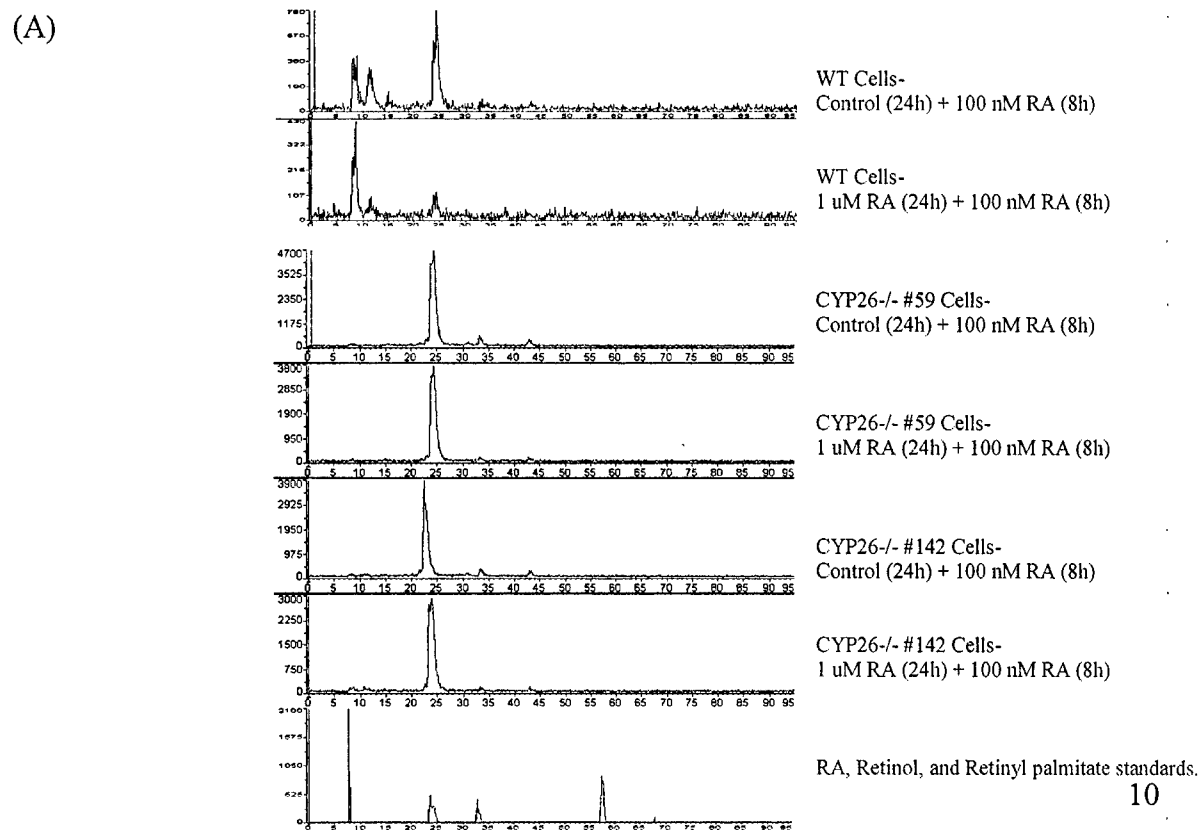

(B)

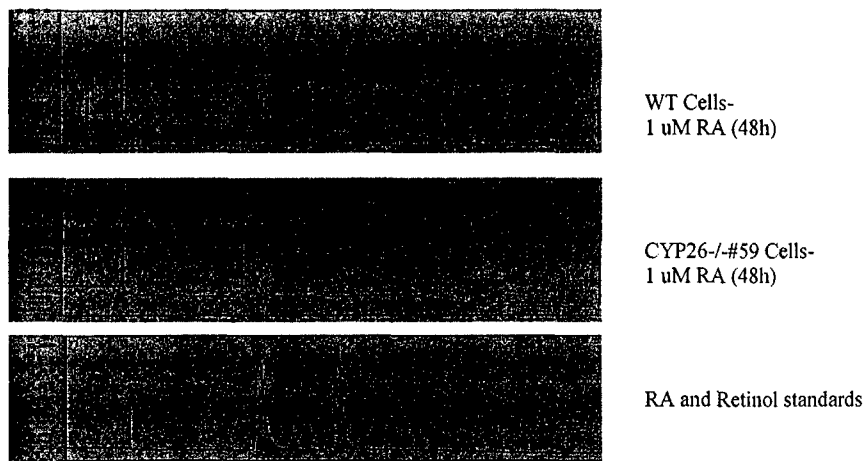

Figure 4. HPLC analysis of RA metabolism in WT and CYP26^{-/-} ES cells. (A) In this experiment, WT or CYP26^{-/-} ES cells were pretreated with either vehicle control or 1 μ M RA. Then, cells were rinsed with PBS and medium containing 100 nM radiolabeled [³H]-RA was replaced. After 8 hours of treatment, medium and cells were collected for retinoid extraction and HPLC analysis. The Y-axis represents counts per minute and the X-axis represents time in minutes. All-trans retinoic acid elutes at approximately 24.7 minutes, while polar metabolites elute sooner between 8 and 14 minutes. (B) In this experiment, WT or CYP26^{-/-} ES cells were treated with 1 μ M non-radioactive RA for 48 hours. Cells and medium were collected for retinoid extraction and HPLC analysis. The Y-axis represents absorption units and the X-axis represents time in minutes. According to the RA and retinol standards, RA elutes at approximately 24 minutes and retinol elutes at approximately 33 minutes.

KEY RESEARCH ACCOMPLISHMENTS

- Evaluated the effects of PA, DHA, RA, and synthetic retinoids on the proliferation of RA-sensitive (MCF-7 and T47D) and RA-resistant (MDA-MB-468) human breast cancer cell lines (Year 1).
- Demonstrated by Northern analysis that CYP26 expression is induced by RA and this RA-induction is enhanced by the addition of PA in MCF-7 cells (Year 1).
- Established a new CYP26^{-/-} ES cell line (Year 2).
- Determined that increasing intracellular concentration of RA does not necessarily increase growth inhibition (Year 2).

REPORTABLE OUTCOMES

N/A

CONCLUSIONS

We had previously shown that the dietary fatty acids, DHA and PA, slightly enhanced RA-induced growth inhibition in human breast cancer cells. Additionally, we found that CYP26 expression in MCF-7 breast cancer cells was induced by RA and this induction was slightly enhanced by the addition of PA. The modest enhancement by the fatty acids to retinoid-signaling was too small for us to determine the mechanism.

In this report, we showed that CYP26 was the key enzyme in the metabolism of RA in WT ES cells. When CYP26 was knocked out in those cells, polar metabolites were not detected. CYP26^{-/-} ES cells grew very fast compared to the WT ES cells, which may be due to the conversion of retinol into 4-oxo-retinol by CYP26 in the WT ES

cells. Retinol may be present in the medium from the fetal bovine serum, which is a necessary supplement. The CYP26^{-/-} ES cells were found to be equally sensitive to RA-induced growth inhibition as WT ES cells. However, by HPLC analysis, CYP26^{-/-} ES cells were found to have higher intracellular levels of RA. This suggested that increasing intracellular levels of RA did not equal increasing growth inhibition. Other studies have implicated that increasing RA availability inside the cells by inhibiting CYP26 should result in growth inhibition (7, 8). Because some cancers were found to express CYP26 at a higher level than normal cells, it was suggested that inhibitors to CYP26 could be used as an anticancer agent (9). However, our data suggested that increasing RA concentrations inside the cells was not enough to inhibit cell proliferation. Further studies will be necessary to fully understand how retinoids specifically affect cell proliferation and cell growth.

REFERENCES

1. L.J. Gudas, Sporn, M.B., Roberts, A.B., in *The Retnoids Biology, Chemistry and Medicine*. M.B. Sporn, Roberts, A.B., and Goodman, D.S., Ed. (Raven Press, New York, 1994) pp. 443-520.
2. P. Chambon, *Faseb J* **10**, 940 (Jul, 1996).
3. L.N. Wei, *Annu Rev Pharmacol Toxicol* **43**, 47 (2003)
4. S. Reijntjes *et al.*, *Dev Biol* **285**, 224 (2005).
5. J.A. White *et al.*, *J. Biol Chem* **272**, 18538 (1997).
6. B.M. van der Leede *et al.*, *J. Biol Chem* **272**, 17921 (1997).
7. J.L. Armstrong *et al.*, *British J. Cancer* **92**, 696 (2005).

8. B. Ozpolat *et al.*, *Am J Hematol* **70**, 39 (2002).
9. C.E. Morag *et al.*, *Mol Cancer Ther* **3**, 363 (2004)

APPENDICES

N/A