

Design of Synchronization Sequences in a MIMO Demonstration System¹

Guangqi Yang, Wei Hong, Haiming Wang, Nianzu Zhang

State Key Lab. of Millimeter Waves, Dept. of Radio Engineering,
Southeast University, Nanjing, 210096, P. R. China
gqyang@emfield.org, weihong@seu.edu.cn

Abstract: MIMO (multi-input and multi-output) wireless communication systems have attracted serious research interest since 1990. It is well accepted that MIMO is a way to breakthrough the wireless capacity bottleneck. However, as the antenna number of a MIMO system increases, the complexity of the system increases dramatically. In a $M \times N$ (M transmitting antennas by N receiving antennas) MIMO system, the receiver have to perform the synchronization on $M \times N$ channels which requires huge computing resource. Synchronization design is one of the great challenges in the design of MIMO systems. This paper presents the synchronization design of a 4 x 4 MIMO demonstration system. In the design, Golay complementary pairs are used to construct the synchronization sequences.

Keywords: synchronization, MIMO, Golay complementary pairs

I. Transmission Model

We have established a point to point demonstration system consists of two access point (AP) equipped with 4 independent antennas and one terminal (TM) equipped with 4 independent antennas. AP and MT communicate with each other in TDD mode. AP provides the timing reference. MT should keep itself synchronized with AP before using uplink. Each downlink frame corresponding to an AP's antenna contains an individual 128-chip preamble for synchronization purpose at MT side. As AP has 4 antennas, there need four different preambles {Pd1, Pd2, Pd3, Pd4}. Similarly, another 4-preamble set {Pu1, Pu2, Pu3, Pu4} is required for being used in uplink frames.

Matched filters (or correlators) are deployed to fulfill synchronization in both uplink and downlink. Apparently, 16 matched filters (or correlators) in total are required in MT. In AP, matched filters (or correlators) of the same number are also required, which are not shown in Figure 1. If implemented in direct correlation manner, the amount of hardware resources required to perform synchronization will reach an unreasonable level. Fortunately, by carefully selecting preambles, the hardware resource cost on the large number of filters can be dramatically reduced.

¹ This work was supported by the 863 High-Tech Program of China under grant 2002AA123031

Report Documentation Page

Form Approved
OMB No. 0704-0188

Public reporting burden for the collection of information is estimated to average 1 hour per response, including the time for reviewing instructions, searching existing data sources, gathering and maintaining the data needed, and completing and reviewing the collection of information. Send comments regarding this burden estimate or any other aspect of this collection of information, including suggestions for reducing this burden, to Washington Headquarters Services, Directorate for Information Operations and Reports, 1215 Jefferson Davis Highway, Suite 1204, Arlington VA 22202-4302. Respondents should be aware that notwithstanding any other provision of law, no person shall be subject to a penalty for failing to comply with a collection of information if it does not display a currently valid OMB control number.

1. REPORT DATE 01 JAN 2005	2. REPORT TYPE N/A	3. DATES COVERED -			
4. TITLE AND SUBTITLE Design of Synchronization Sequences in a MIMO Demonstration System		5a. CONTRACT NUMBER			
		5b. GRANT NUMBER			
		5c. PROGRAM ELEMENT NUMBER			
6. AUTHOR(S)		5d. PROJECT NUMBER			
		5e. TASK NUMBER			
		5f. WORK UNIT NUMBER			
7. PERFORMING ORGANIZATION NAME(S) AND ADDRESS(ES) State Key Lab. of Millimeter Waves, Dept. of Radio Engineering, Southeast University, Nanjing, 210096, P. R. China		8. PERFORMING ORGANIZATION REPORT NUMBER			
9. SPONSORING/MONITORING AGENCY NAME(S) AND ADDRESS(ES)		10. SPONSOR/MONITOR'S ACRONYM(S)			
		11. SPONSOR/MONITOR'S REPORT NUMBER(S)			
12. DISTRIBUTION/AVAILABILITY STATEMENT Approved for public release, distribution unlimited					
13. SUPPLEMENTARY NOTES See also ADM001846, Applied Computational Electromagnetics Society 2005 Journal, Newsletter, and Conference., The original document contains color images.					
14. ABSTRACT					
15. SUBJECT TERMS					
16. SECURITY CLASSIFICATION OF:			17. LIMITATION OF ABSTRACT	18. NUMBER OF PAGES	19a. NAME OF RESPONSIBLE PERSON
a. REPORT unclassified	b. ABSTRACT unclassified	c. THIS PAGE unclassified	UU	4	

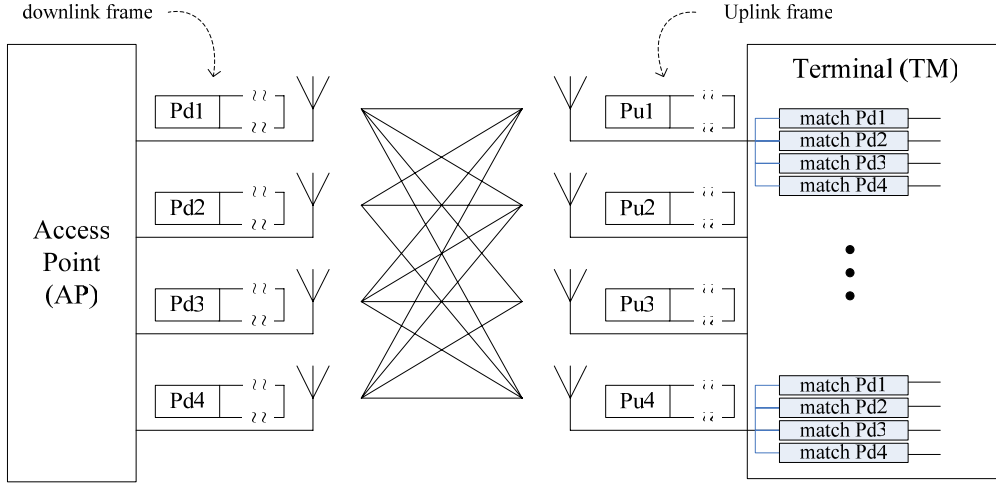

Figure 1 A 4 X 4 MIMO demonstration system

II. Design of Preambles

2.1 Uplink preambles

Note that MT transmits frames after it has finished timing acquisition. At AP, the timing of received uplink frames have small offset from the timing reference. AP only needs to perform preamble search within a limited range. Thus a method that was proposed for generating cell synchronization sequence in WCDMA TDD mode^[2] can be adopted here. In our demonstration system, 4 preambles are derived from a concatenated extended Golay complementary pair of length $N=64$ by means of *different code offset*. Let $a(n)$, $b(n)$ denote two sequences of the Golay binary complementary pair. The first preamble (Pu1) for uplink which corresponds to the first antenna is constructed as follows.

- 1) Add pre and post cyclic extensions to $a(n)$ and $b(n)$, with the $L=16$
- 2) Concatenating extended sequences obtained in step 1, (Fig. 2).
- 3) Multiply the concatenated sequence from step2 by $(1+j)$ to form a complex sequence.

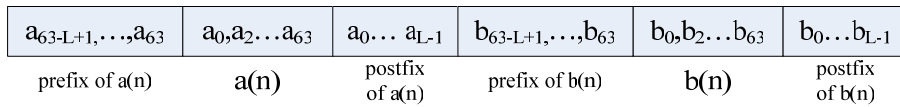

Figure2 concatenated extended Golay complementary pair

The other preambles (Pu2, Pu3, Pu4) corresponding to the other 3 antennas are generated by using the same steps as above except that $a(n)$ and $b(n)$ are replaced by their cyclically shifted versions, $a_k(n)$ and $b_k(n)$. k is an integer inside $[0, N-1]$ that denotes the number of shifted bits. For example

$$a_k(m) = \begin{cases} a(m+k) & \text{if } 1 \leq m \leq N-k \\ a(m-k-N) & \text{if } N-k+1 \leq m \leq N \end{cases}$$

The three values of k for generating Pu2, Pu3, Pu4 are 16, 32, 48, respectively.

2.2 Downlink preambles

Uplink preamble set is not applicable for downlink because MT does not constrain the preamble search operation in a limited range. In our demonstration system, four downlink preambles (Pd1, Pd2, Pd3, Pd4) are derived from 2 binary Golay complementary pairs. Let $c1(n)$, $c2(n)$ denote one pair, and $d1(n)$, $d2(n)$ denote the other pair. We defined 4 complex sequences by combining $c1(n)$, $c2(n)$, $d1(n)$, $d2(n)$. Let $e(n)=c1(n)+c2(n)*j$, $f(n)=c1(n)-c2(n)*j$, $g(n)=d1(n)+d2(n)*j$, $h(n)=d1(n)-d2(n)*j$. Preamble Pd1 is constructed based on $e(n)$ and $f(n)$ and Pd2 is constructed based on $e(n)$ and $-f(n)$.

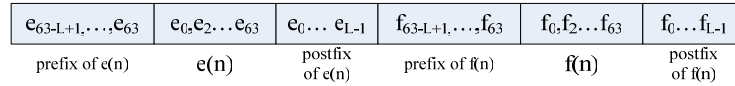

Fig.3 Construct a preamble based on $e(n)$ and $f(n)$

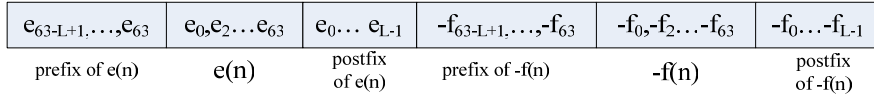

Fig.4 Construct a preamble based on $e(n)$ and $-f(n)$

Similarly, Pd3 and Pd4 are defined by using $(g(n) h(n))$ and $(g(n) -h(n))$ respectively.

III. Characteristics of the Preambles

3.1 Uplink preambles

The aperiodic autocorrelation and cross correlation properties of the uplink preambles are checked within the main peak window with the width of 32 chips. Simulation result shows the uplink preambles have satisfied aperiodic autocorrelation and cross correlation properties (figure5).

3.2 downlink preambles

By searching proper Golay complementary pairs, the peak of side lobe in aperiodic autocorrelation and aperiodic cross correlation curves can be reduced to no more than 21% of the main peak (figure6).

IV. Implementation of matched filters

4.1 Uplink matched filters

Matched filters for uplink preambles are implemented with Enhanced Golay Correlators (EGC's) [2] as in Figure7(a).

4.2 Downlink matched filters

The similarity between Pd1 and Pd2 makes it possible to share most part of resources of correlator for Pd1 with correlator for Pd2 as shown in Figure7(b).

V. Conclusions

This paper presents a preamble design scheme as well as Corresponding low complexity implementation for a 4X4 MIMO demonstration system. At the AP side, this scheme achieves a complexity of $2 \log_2(T)$ operations per sample, where T is the total taps of all matched filters. At the MT side, a complexity of $\log_2(T)$ is achieved.

References

[1] M.J.E. Golay, "Complementary Series", IRE Trans. On Information Theory,

Vol.IT-7,pp.82-87, April 1961

- [2] Marian Rudolf and Bruno Jechoux, "Design of Concatenated Extended Complementary Sequences for inter-base station synchronization in WCDMA TDD mode" Global Telecommunications Conference, 2001. GLOBECOM '01. IEEE
- [3] S.Z. Budisin, "Efficient pulse compressor for Golay complementary sequences," Elec.Lett., 27, no. 3, pp. 219–220, 31st Jan. 1991.

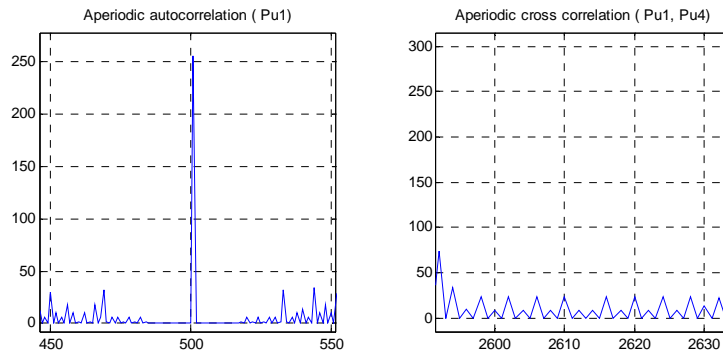

Figure5 example of aperiodic autocorrelation and cross correlation properties of Pu1

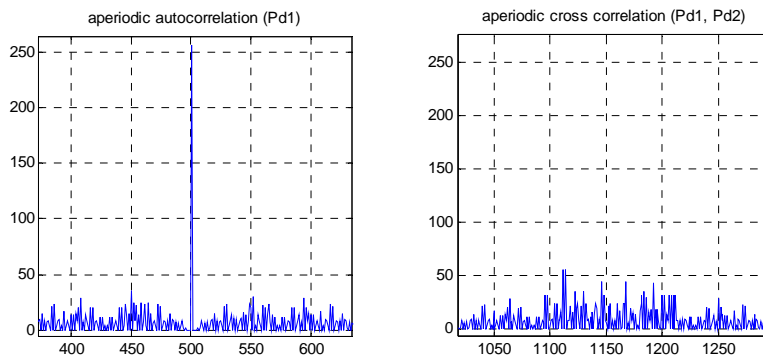

Figure6 example of aperiodic autocorrelation and cross correlation properties of Pd1

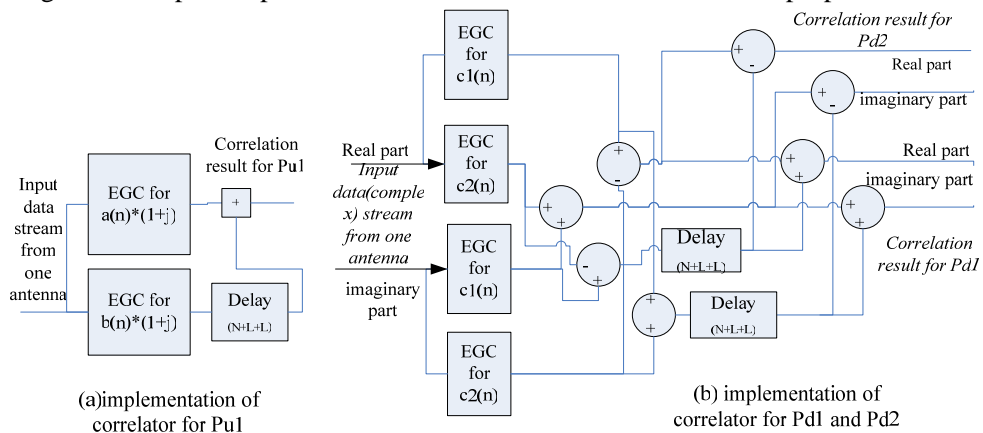

Figure7 Implementation of matched filters