

NASA TECHNICAL NOTE

1

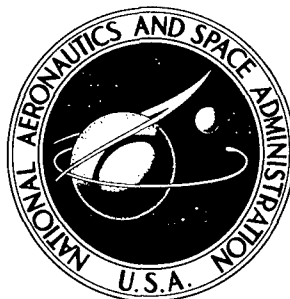

NASA TN D-3350

2

NASA TN D-3350

083851 P
~~63850~~

DISTRIBUTION STATEMENT A
Approved for Public Release
Distribution Unlimited

PROPERTY OF:

USE OF CARBON DIOXIDE TO CALIBRATE INSTRUMENTS FOR DETERMINATION OF CARBON BELOW 50 PARTS PER MILLION IN METALS

by *Emery J. Merkle and Judson W. Graab*

Lewis Research Center
Cleveland, Ohio

20060516179

USE OF CARBON DIOXIDE TO CALIBRATE INSTRUMENTS
FOR DETERMINATION OF CARBON BELOW 50
PARTS PER MILLION IN METALS

By Emery J. Merkle and Judson W. Graab

Lewis Research Center
Cleveland, Ohio

NATIONAL AERONAUTICS AND SPACE ADMINISTRATION

For sale by the Clearinghouse for Federal Scientific and Technical Information
Springfield, Virginia 22151 - Price \$0.05

USE OF CARBON DIOXIDE TO CALIBRATE INSTRUMENTS FOR DETERMINATION OF CARBON BELOW 50 PARTS PER MILLION IN METALS*

by Emery J. Merkle and Judson W. Graab

Lewis Research Center

SUMMARY

In the determination of carbon below 50 parts per million organic compounds have been used for calibration in the absence of suitable metallic standards. The addition of gaseous carbon dioxide (CO_2) as a calibration technique is proposed. A comparison of standardizations with an organic compound and with CO_2 additions is presented. A significant improvement in the precision of a calibration curve by using CO_2 is demonstrated.

INTRODUCTION

The determination of carbon below 50 parts per million in metals such as tungsten, molybdenum, and ductile chromium is becoming increasingly important. The chromatographic technique is of interest for this purpose because of its inherent sensitivity, speed, and ease of operation. Several chromatographic carbon analyzers, employing different techniques, have been described (refs. 1 to 3). The chromatographic carbon analyzer chosen in this report uses a system that traps the evolved carbon dioxide (CO_2) on a molecular sieve and separates it from oxygen by means of a silica gel column. The measurement is then made by a thermal conductivity detector and displayed on an integrator counter.

The calibration of instruments for determining carbon below 50 parts per million must rely on the use of CO_2 from sources other than metallic standards since none are commercially available. Primary standard potassium acid phthalate (PAP) has been used to prepare calibration curves for low carbon determinations (refs. 4 and 5). The chromatographic carbon analyzer used here was calibrated with PAP.

Because of the possibility of incomplete combustion of the PAP, due to shorter burn time and higher oxygen flow rate, comparisons were made of the CO_2 obtained from the

* Published in Analytical Chemistry, vol. 38, no. 1, Jan. 1966, p. 159.

PAP with known amounts of gaseous CO_2 . Carbon dioxide was added by means of a gas-tight syringe, a technique commonly used in gas chromatography. During this study the direct addition of CO_2 as a calibration technique was investigated. The purpose of this report is to evaluate the method of direct addition of CO_2 and compare it with the PAP method of calibration.

APPARATUS AND REAGENTS

The equipment used consisted of a catalyst furnace, model 507-400; a copper oxide catalyst, part number 501-80; ceramic disks, part numbers 528-42; an induction furnace, model 521; and a chromatographic carbon analyzer, model 589-400 (Laboratory Equipment Corporation). Other equipment consisted of a gastight microliter syringe with Chaney adapter, model number 1725 (Hamilton Company), a diffusion-resistant metal diaphragm regulator with a septum attached for sampling, 1/8- by 3/8-inch silicone rubber injector septums, and research grade carbon dioxide gas.

The potassium acid phthalate disks were prepared in the following manner (ref. 5). An aqueous solution of primary standard PAP containing 100 micrograms of carbon per milliliter was prepared. Appropriate aliquots of this solution were added, by using a microburette, to porous ceramic disks previously ignited in oxygen at 900°C for 15 minutes. The disks were then dried in an oven at 105°C for 1 hour. A schematic diagram of the apparatus is shown in figure 1. A catalyst furnace which heats a copper tube containing the copper oxide catalyst was installed on the inlet side of the oxygen purifying train to reduce the blank attributed to carbonaceous impurities in the cylinder oxygen. A lower blank was obtained when the catalyst furnace was used.

All gas connections between the oxygen supply and the induction furnace were made with stainless steel tubing and fittings. Other connections were made with nylon connectors and a gum rubber tubing necessary for a flexible connection between the furnace pedestal base and the dust trap. A septum, for the introduction of the CO_2 , was installed

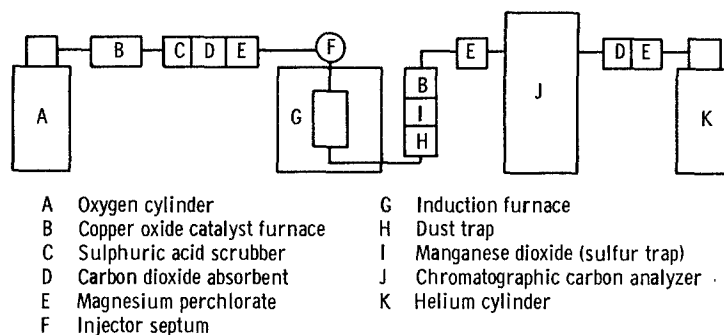

Figure 1. - Schematic diagram of apparatus for carbon determination.

TABLE I. - CONDITIONS FOR COMBUSTION FOR CHROMATOGRAPHIC DETERMINATION OF CARBON

Oxygen pressure, lb/sq in.	8
Oxygen flow, liter/min	1
Combustion and collection time, min	2
Helium pressure, lb/sq in.	20
Helium flow, ml/min	300
Attenuator setting	1
Platinum susceptor disk	
Thickness, mm	1
Diameter, mm	25

in the oxygen line before the connection to the quartz combustion tube. One advantage of this septum position was that CO₂ added at this point was subjected to the same conditions experienced by the CO₂ formed during the combustion of a sample. Another advantage was that, when CO₂ was used, this arrangement afforded a simple method for detecting leaks between the furnace and the chromatographic carbon analyzer. When a given amount of CO₂ was injected into the septum, a lower than normal response of the chromatograph was an indication that a leak was present.

The Chaney adapter on the syringe was set to deliver approximately 30 microliters. The syringe was then calibrated with mercury to determine accurately the volume for this setting. Larger volumes were achieved by duplicate and triplicate additions with the same syringe.

The amplifier gain of the chromatograph was adjusted to a setting which gave the best combination of sensitivity and precision. This was done by determining the standard deviation of repeated injections of CO₂ at various gain settings with the attenuator in position 1, the highest sensitivity of the detector.

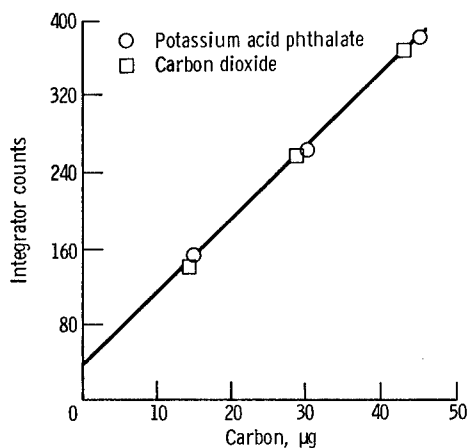

Figure 2. - Calibration with potassium acid phthalate and carbon dioxide gas.

PROCEDURE

Table I is a list of operating conditions used in the calibration of the chromatograph for carbon.

The platinum susceptor was used with the induction furnace for heating when calibrating with PAP. The platinum susceptor was also heated when calibrating with the CO₂ and to determine the instrument blank. The syringe was flushed several times with CO₂ before injection into the injector septum. The syringe was held as close as possible to its flange, to minimize expansion and loss of CO₂ due to heat transfer to the barrel during handling. The carbon equivalent of the CO₂ added was calculated by using the perfect gas law.

RESULTS AND DISCUSSION

Figure 2 shows a calibration curve prepared by using the two methods of calibration. The data show that both methods give equivalent results at the levels investigated. Furthermore, the close agreement demonstrates that the combustion of PAP is complete under these conditions.

The data shown in table II represent 6 to 10 determinations at each level over a period of 2 days. Also included is a series of apparatus blanks obtained by heating the susceptor. Standard deviations are calculated for the integrator counts found at each level of calibration. Included in the standard deviation of the blank are random errors associated with the induction furnace and the chromatograph. These are shown to be equivalent to no more than ± 1 microgram at the 95 percent confidence level. Although the two methods yield comparable precision at the 30- and 45-microgram levels, significant improvement in precision is shown for the CO₂ injections at the 15-microgram level.

Probably the greatest contributors to the poorer precision of the PAP are the random errors in preparation, storage, and handling. The use of gaseous CO₂ eliminates virtually all errors associated with preparation and storage, and greatly simplifies the addition of reproducible quantities of CO₂.

TABLE II. - COMPARISON OF PRECISION OF POTASSIUM
ACID PHTHALATE AND CARBON DIOXIDE
CALIBRATION PROCEDURES

Integrator counts	Equivalent carbon, μg	PAP	CO ₂	PAP	CO ₂
		Standard deviation in counts, S*		Relative standard deviation in counts, percent	
37	----	3.8	3.8	10.4	10.4
152	15.0	12.7	---	8.3	----
140	14.3	----	5.6	----	4.0
262	30.0	6.9	---	2.6	----
256	28.6	----	5.7	----	2.2
381	45.0	8.4	---	2.2	----
366	42.9	----	6.5	----	1.8

* $S = \sqrt{\sum d^2 / (n - 1)}$, where d is the deviation from the average and n is the number of determinations.

[Conclusions]
CONCLUDING REMARKS

[The additions of microliter quantities of CO₂ by means of a gastight syringe can be used to construct calibration curves for low-level carbon analyses. The results, while fully equivalent in accuracy to PAP, are more precise, especially at the low calibration points. Other advantages of using CO₂ are (1) the PAP disks and the standard solutions used in their preparation are eliminated and (2) the addition of CO₂ to the instrument is facilitated.

The addition of gaseous CO₂ has been used in this study for the calibration of the conductometric carbon apparatus and should have application for the calibration of an inert gas fusion apparatus for oxygen analysis. *Jew d*

Lewis Research Center,
National Aeronautics and Space Administration,
Cleveland, Ohio, June 24, 1965.

REFERENCES

1. Mooney, J.B.; and Garbini, Leo J.: A Sensitive Carbon Determination by Combustion and Gas Chromatography. Paper presented at Analytical Chem. and Appl. Spectroscopy Conf., Pittsburgh (Pa.), Mar. 5-9, 1962.
2. Karpathy, Oliver C.: Carbon Determination of Ferrous Alloys with a Newly Developed Gas Chromatograph. Paper presented at Analytical Chem. and Appl. Spectroscopy Conf., Pittsburgh (Pa.), Mar. 4-8, 1963.
3. Walker, J.M.; and Kuo, C.W.: Carbon Determination in Ferrous Metals by Gas Chromatography. Anal. Chem., vol. 35, no. 13, Dec. 1963, pp. 2017-2019.
4. Harris, W.F.; and Revesz, R.N.: An Investigation of the Determination of Microgram Quantities of Carbon in Iron. Paper presented at Analytical Chem. and Appl. Spectroscopy Conf., Pittsburgh (Pa.), Mar. 1-5, 1965.
5. Gordon, W.A.; Tunney, Z.T.; and Graab, J.W.: Combustion - Conductometric Determination of Less Than 10 p.p.m. Carbon in Tungsten. Anal. Chem., col. 36, no. 7, June 1964, pp. 1396-1398.