

SHIP PRODUCTION COMMITTEE
FACILITIES AND ENVIRONMENTAL EFFECTS
SURFACE PREPARATION AND COATINGS
DESIGN/PRODUCTION INTEGRATION
HUMAN RESOURCE INNOVATION
MARINE INDUSTRY STANDARDS
WELDING
INDUSTRIAL ENGINEERING
EDUCATION AND TRAINING

June 1976
NSRP 0002

THE NATIONAL SHIPBUILDING RESEARCH PROGRAM

Proceedings of the REAPS Technical Symposium

Paper No. 14: Shipbuilding Equipment at Mitsubishi

U.S. DEPARTMENT OF THE NAVY
CARDEROCK DIVISION,
NAVAL SURFACE WARFARE CENTER

Report Documentation Page

Form Approved
OMB No. 0704-0188

Public reporting burden for the collection of information is estimated to average 1 hour per response, including the time for reviewing instructions, searching existing data sources, gathering and maintaining the data needed, and completing and reviewing the collection of information. Send comments regarding this burden estimate or any other aspect of this collection of information, including suggestions for reducing this burden, to Washington Headquarters Services, Directorate for Information Operations and Reports, 1215 Jefferson Davis Highway, Suite 1204, Arlington VA 22202-4302. Respondents should be aware that notwithstanding any other provision of law, no person shall be subject to a penalty for failing to comply with a collection of information if it does not display a currently valid OMB control number.

1. REPORT DATE JUN 1976		2. REPORT TYPE N/A		3. DATES COVERED -	
4. TITLE AND SUBTITLE The National Shipbuilding Research Program: Proceedings of the REAPS Technical Symposium Paper No. 14: Shipbulding Equipment at Mitsubishi				5a. CONTRACT NUMBER	
				5b. GRANT NUMBER	
				5c. PROGRAM ELEMENT NUMBER	
6. AUTHOR(S)				5d. PROJECT NUMBER	
				5e. TASK NUMBER	
				5f. WORK UNIT NUMBER	
7. PERFORMING ORGANIZATION NAME(S) AND ADDRESS(ES) Naval Surface Warfare Center CD Code 2230 - Design Integration Tools Building 192, Room 128 9500 MacArthur Blvd Bethesda, MD 20817-5700				8. PERFORMING ORGANIZATION REPORT NUMBER	
9. SPONSORING/MONITORING AGENCY NAME(S) AND ADDRESS(ES)				10. SPONSOR/MONITOR'S ACRONYM(S)	
				11. SPONSOR/MONITOR'S REPORT NUMBER(S)	
12. DISTRIBUTION/AVAILABILITY STATEMENT Approved for public release, distribution unlimited					
13. SUPPLEMENTARY NOTES					
14. ABSTRACT					
15. SUBJECT TERMS					
16. SECURITY CLASSIFICATION OF:			17. LIMITATION OF ABSTRACT SAR	18. NUMBER OF PAGES 38	19a. NAME OF RESPONSIBLE PERSON
a. REPORT unclassified	b. ABSTRACT unclassified	c. THIS PAGE unclassified			

DISCLAIMER

These reports were prepared as an account of government-sponsored work. Neither the United States, nor the United States Navy, nor any person acting on behalf of the United States Navy (A) makes any warranty or representation, expressed or implied, with respect to the accuracy, completeness or usefulness of the information contained in this report/manual, or that the use of any information, apparatus, method, or process disclosed in this report may not infringe privately owned rights; or (B) assumes any liabilities with respect to the use of or for damages resulting from the use of any information, apparatus, method, or process disclosed in the report. As used in the above, "Persons acting on behalf of the United States Navy" includes any employee, contractor, or subcontractor to the contractor of the United States Navy to the extent that such employee, contractor, or subcontractor to the contractor prepares, handles, or distributes, or provides access to any information pursuant to his employment or contract or subcontract to the contractor with the United States Navy. ANY POSSIBLE IMPLIED WARRANTIES OF MERCHANTABILITY AND/OR FITNESS FOR PURPOSE ARE SPECIFICALLY DISCLAIMED.



UMTRI

70060

Proceedings of the
REAPS Technical Symposium
June 15-16, 1976
Atlanta, Georgia

Research and
Engineering for
Automation and
Productivity in
Shipbuilding

IIT RESEARCH INSTITUTE
10 WEST 35 STREET
CHICAGO, ILLINOIS 60616

Transportation
Research Institute

© 1976

IIT RESEARCH INSTITUTE

ALL RIGHTS RESERVED - NO PART OF
THIS BOOK MAY BE REPRODUCED IN ANY
FORM WITHOUT PERMISSION IN WRITING
FROM IIT RESEARCH INSTITUTE EXCEPT
TO QUOTE BRIEF PASSAGES IN CONNECTION
WITH A REVIEW FOR A TRADE PUBLICATION
OR THE PRESS

SHIPBUILDING EQUIPMENT AT MITSUBISHI

A. Kamata

Mitsubishi Heavy Industries, Ltd.

Tokyo, Japan

Mr. Kamata is Staff Superintendent in Mitsubishi's Ship Research and Development Department.

PART I

Shipyard Applications of the Mitsubishi

Horizontal Fillet Welding Robot

1. HULL BLOCK ASSEMBLING AND DEVELOPMENT OF ROBOT

A hull structure consists of various parts, but the same type of structure exists enough many in a ship parallel part compared with fore and aft ship parts.

As we can see on Fig. 1 showing a midship section of a tanker, the lattice structures with longitudinal frames and transversal webs are welded to panels of hull plates and deck plates at the parallel part of a ship. This lattice structure is assembled into blocks at the assembly stage and are erected on berths or building docks.

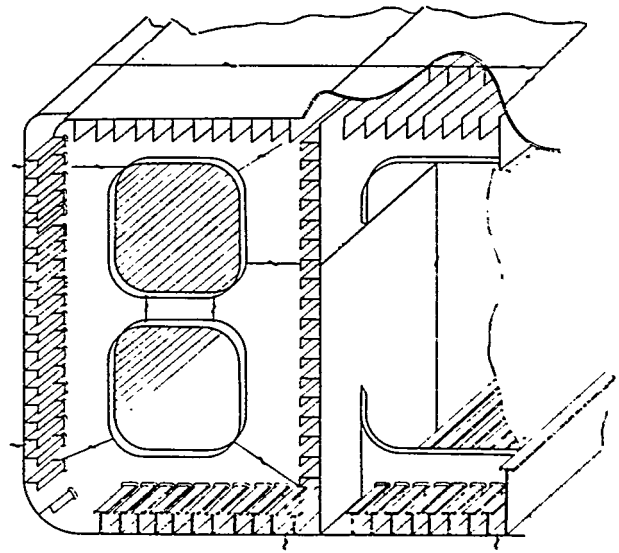

Fig. 1 Midship section of para-ler part (150,000Dwt tanker)

Table 1 Welding length of hull construction (150,000 DWt tanker)

Welding Structure	Sub assembly stage								Assembly stage								Erection stage								Total	
	Fillet welding						Butt weld.		Fillet welding						Butt weld.											
	D		V		O		L	%	D		V		O		L	%	D		V		O		L	%		
	L	%	L	%	L	%			L	%	L	%	L	%			L	%	L	%	L	%			L	%
1 Fore curved part	349	7.2	30	0.6	4	0.1	34	0.7	321	6.6	101	2.1	20	0.4	12	0.2	49	1.0	12	0.2	10	0.2	47	1.0	989	20.5
2 Parallel part	863	18.0	73	1.5	11	0.2	83	1.7	793	16.4	249	5.2	50	1.0	30	0.6	126	2.6	32	0.7	25	0.5	122	2.5	2457	50.9
3 Aft curved part	307	6.4	26	0.5	4	0.1	29	0.6	282	5.8	89	1.8	18	0.5	11	0.2	44	0.9	11	0.2	9	0.2	43	0.9	873	18.1
4 Upper structure	160	3.3	14	0.3	2	-	15	0.3	147	3.0	46	1.0	9	0.2	6	0.1	46	1.0	12	0.2	9	0.2	45	0.9	511	10.6
Sub Total	1679	34.8	143	3.0	21	0.4	161	3.3	1543	31.1	485	10.0	97	2.0	59	1.2	265	5.5	67	1.4	53	1.1	257	5.3	-	-
Total	2004						41.5		2184						45.2		642						13.3		4830	100

- D. . Downward
- V. . Vertical
- O. . Overhead
- L. : Welding length in 100 m

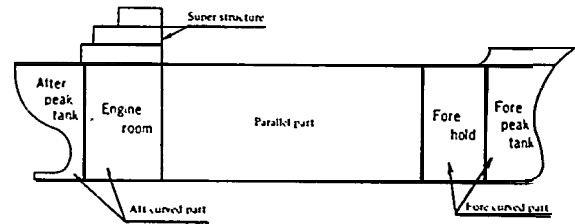
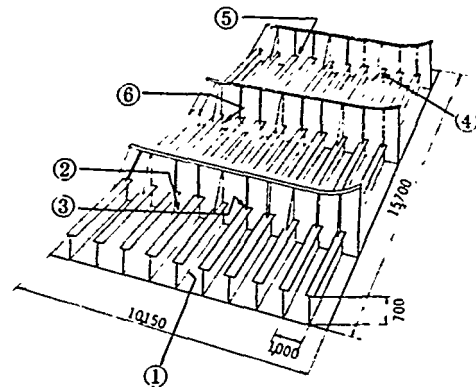

Table 1 shows the percentages of each welding length in various building stages of a 150,000Dwt tanker. Welding length at the parallel part reaches about 50% of whole length for a ship of which 45% is welded at the assembly stage. Table 2 shows each welding joint length of panel blocks of a 150,000Dwt tanker bottom shell block in the assembly stage. Lattice horizontal fillet welding length reaches about 70% of the whole welding length at this stage, though percentage might change in accordance with block's size.

Table 2 Example of various welding joint length of panel block in assembly stage (15QO00DWt tanker bottom shell block)

Welding joint	Welding position	Weld. length/block	Robot applicable weld. length
① Frame × panel	Downward	314	314 m
② Web × panel	- " -	48	48
③ Stiffner × longi. face	"	14	
④ Bracket × longi. face	- " -	20	
⑤ Rib × longi. face	- " -	15	
⑥ Frame × web	Vertical	90	
Total		501	362



So far, we have adopted the gravity welding for this horizontal fillet welding with one man six or seven welding machines. But, because of the shortness of the welding length and the occurrence of non-welding part or repair of joint part of welding rod in the gravity welding as well as of the growing need of operation of high intensity, automatic welding of high efficiency has gradually come to be sought after.

The welding system newly developed by M.H.I. consists of a lattice horizontal fillet welding robot, which enables continuous automatic MIG welding on the circuit of the lattice, and a handling apparatus which controls many robots. By pushing the button on the handling panel, the operator can throw the welding robot into the lattice, and thereafter, the robot goes along the walls and repeats the change of direction automatically at each corner. Upon finishing the circuit welding, the robot returns to the indicated position to be lifted automatically by the handling apparatus and moved over to the next lattice. With this system, it is possible to designate the shape of the lattice and the leg length of each side beforehand. Furthermore, such function as start, stop, detection of the non-welded part of the frame (scallops, slots), intermittence of the welding arc and emergency stop can be performed automatically. Thus, the welding robot takes the place of man in the whole welding process of the horizontal fillet welding joint in the lattice.

Table 3 Panel block assembling method and automatic welding

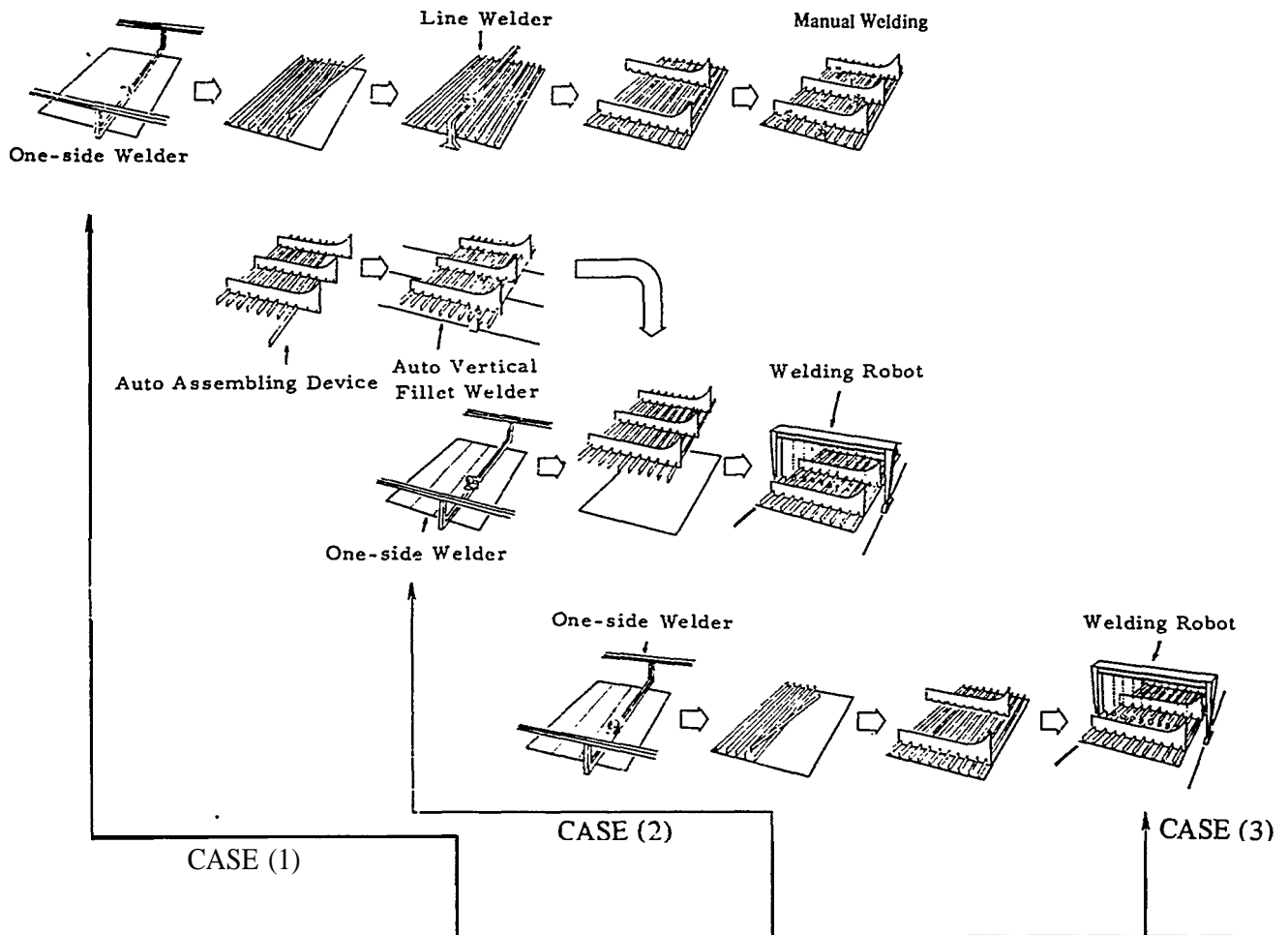

Assembly method		Using line welder	Lattice assembly	Individual disposing
HOW TO automate	Panel joining	Automatic submerged arc one - side welding 100%		
	Horizontal fillet welding of panel to frame and web	Line welder 84%	(a) Gravity welding 0% (b) With small submerged arc welder 63% (c) Welding robot 99%	
	Vertical fillet wg of frame to web	Manual welding 0% (difficult to automate)	Automatic vertical fillet welder 90%	Manual welding 0% (difficult to automate)
Advantage		1) Possibility of high efficiency welding of horizontal fillet welding of frame to panel	1) High productivity in case of using method (b) or (c). 2) Possibility of using key slot.	1) Small space and investment. 2) Possibility of using key slot.
Disadvantage		1) Increase of total wg. length due to use of collar plates. 2) Medium automation grade considering whole assembly stage. 3) High investment.	1) Necessity of assembling tables. 2) High investment for automatic assembling device.	Long time to assemble

Remark : % shows rate of automation

Table 3 compares production stages from the view points of assembly methods and welding automation. The panel joining is almost 100% automated by means of the one side automatic welding technique, however, the automation of vertical fillet welding is difficult to realize in case of (1)* and (3)*. On the other hand, the welding robot is effective for high efficiency of horizontal fillet welding in case of (2)* and (3)*. The robot enables almost perfect automation of assembly and welding of panel blocks with utilization of automatic lattice structure assembling devices (to insert longitudinal frames to transversal webs) and of automatic vertical fillet welders.





*Note:

- (1) Assembling of longitudinal frames to panel plates, then assembling of transversal webs, attaching transversal webs to already assembled frames/panels.
- (2) Assembling of lattices with longitudinal frames and transversal webs, then attaching assembled lattices to panel plates.
- (3) Disposing longitudinal frames on panels, then disposing transversal webs on them.

2. Welding Robot

2.1 Principal Function

Principal function and characteristics of welding robot are as follows.

- (1) While maintaining the wire aiming point and the speed of the tip of the welding torch at the corner equally with the straight line part, change of direction is repeated to allow the directed lattice shapes (four kinds, , , , ) to be welded and the welding to be stopped automatically.
- (2) On each side, either one of the designated leg length of the two stages is selected automatically as preset.
- (3) Such non-welded parts as scallops and slots etc, are automatically detected to make possible intermittent welding.
- (4) After finishing the welding the robot returns automatically to the indicated position.

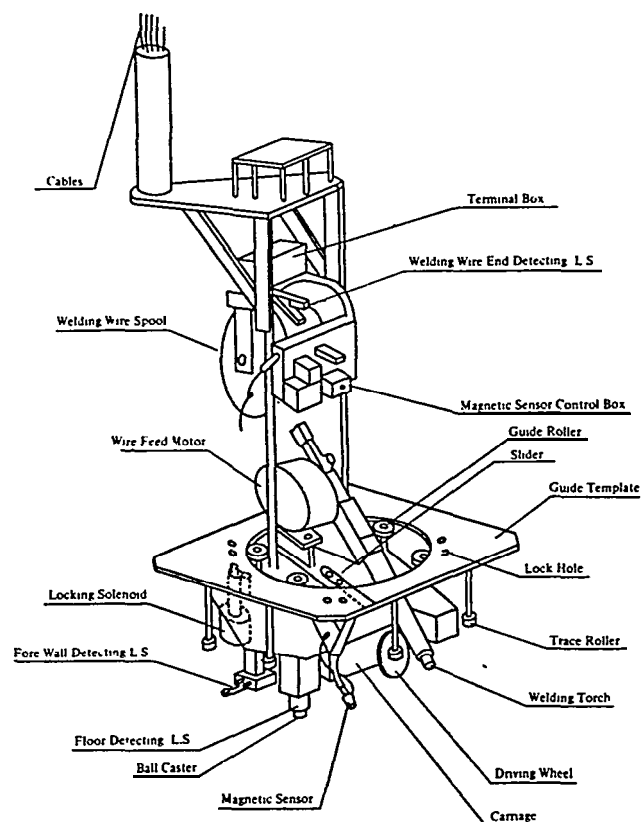

Fig. 2 Schematic figure of lattice horizontal fillet welding robot machine

2.2 Construction of Welding Robot

The construction of the welding robot's body is shown in Fig. 2.

The carriage is supported by driving wheels and casters, and the guiding plate is attached so as to rotate by the guide roller fixed to the carriage. On each side of the guiding plate are mounted four rollers that follow the vertical plate. The guiding plate and the carriage are locked, when running straight, by the locking hole in the solenoid for locking and the guiding plate. The driving wheels always follow the walls. All these combined prevents the vibration of the carriage.

On the upper surface of the carriage, is attached a slider with a magnetic sensor which detects the non-welded part and the welding torch can move forward and backward to enable the magnetic sensor and the welding torch to move along the groove under the guiding plate, when rotating. Thus the slider can guide the sensor and the torch without changing the aiming point at the corner.

2.2.1. Rotation Mechanism

(1) Rotating movement

The robot rotates when reaches to the end part of straight line by catching information that the fore wall detecting limit switch touches the next vertical plate (a frame or web). Rotating movement is done by the release of lock and the reversal of driving wheel.

(2) Shape of guide groove for welding torch

The magnetic sensor and welding torch slide on the sliders being guided along the guide groove which is equipped under surface of the guide template in order to keep the constant distance from the welding torch to the vertical plate when rotating movement at the corner parts.

The shape of this groove is calculated by equation (1) and shown on Figure 3.

$$r = \frac{R}{\cos \theta} - \ell \quad \dots\dots\dots(1)$$

where:

- R: Distance from center of guide template to wire aiming position (constant)
- ℓ : Distance from wire aiming position to center of guide groove (constant)
- r: Distance from center of guide groove to center of guide template

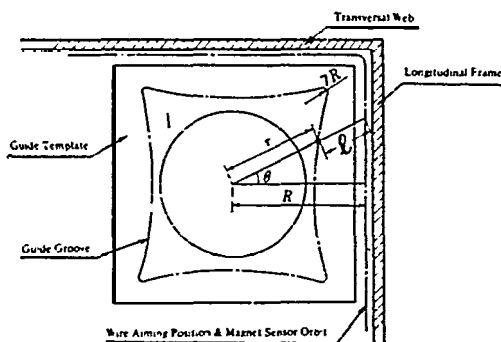

Fig. 3 Shape of weking torch guiding groove

At the place where θ is 45 degrees, the groove is, however, rounded with 7 mm radius in order to smoothen the movement of the torch and to escape from already welded vertical bead.

2.2.2 Speed control at corner part

The speed of the wire aiming position of the torch must be kept constant at the straight line part and the corner part as well. The static Leonard controls the driving wheel speed with 7 kinds of speed control signals in order to keep the speed within $\pm 2.5\%$ deviation.

2.2.3 Control of non-welded part

In order to weld automatically the four sides of a rectangle by the robot, it must be performed intermittent welding at the non-welded parts. The difficult problem of the intermittent welding is as follows. That is, even if the sensor detects the welding stop point, the torch must continue welding until the time when the torch reaches the real welding stop point, and similarly even if the sensor detects the welding start point, the torch must not start welding until the torch reaches the real welding start point;

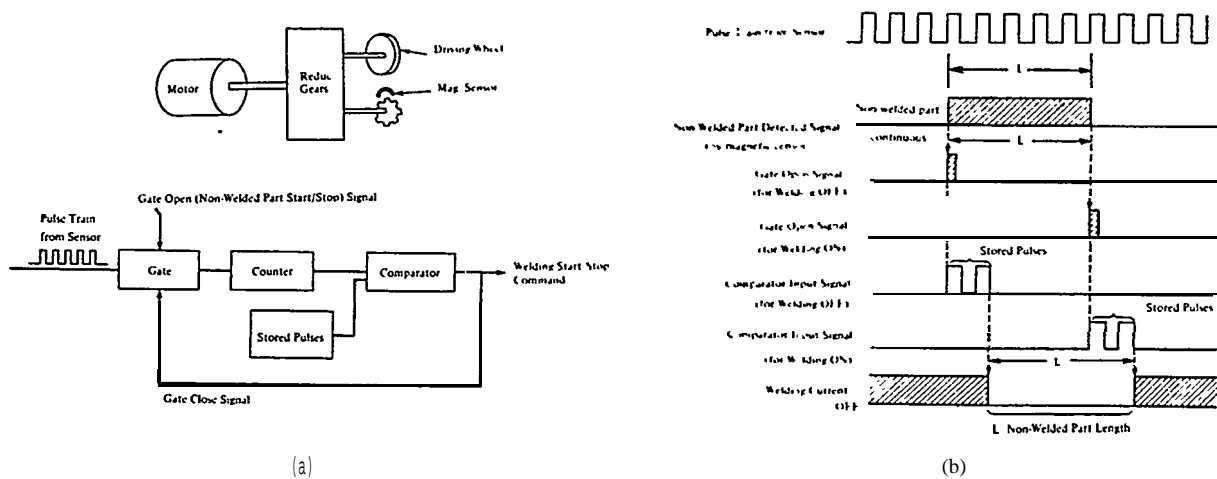

Fig. 4 Control of non-welded part

We solved this problem on the robot by applying electric pulses which are converted from the driving wheel rotation. Figure 4 (a) shows the mechanical elements for this conversion. The pulse generating gear is connected to the driving wheel through the reducing gears with a fixed gear ratio. A magnetic sensor in front of the gear generates pulses of which the number is proportional to the number of passing teeth, i.e., to moving distance of the carriage. So the pulse train is being continuously generated during carriage movement. Fig. 4 (b) shows the control of non-welded parts.

3. WELDING SYSTEM

For the practical use of the welding robot, it is required that one man (or two) can handle many machines from the point of efficiency. So far in this kind of handling, an operator sets and handles the welding machines one by one, in which case he has only a limited number of machines to handle. To overcome this, a system has been developed wherein many robots can be operated at the same time.

In other words, in this system, many welding robots are simultaneously thrown into each lattice, and thereafter, one operator can handle operation from welding on circuit of a lattice to the movement to the next lattice after finishing welding. This system consists of welding robots, the concentrated control box and the handling apparatus.

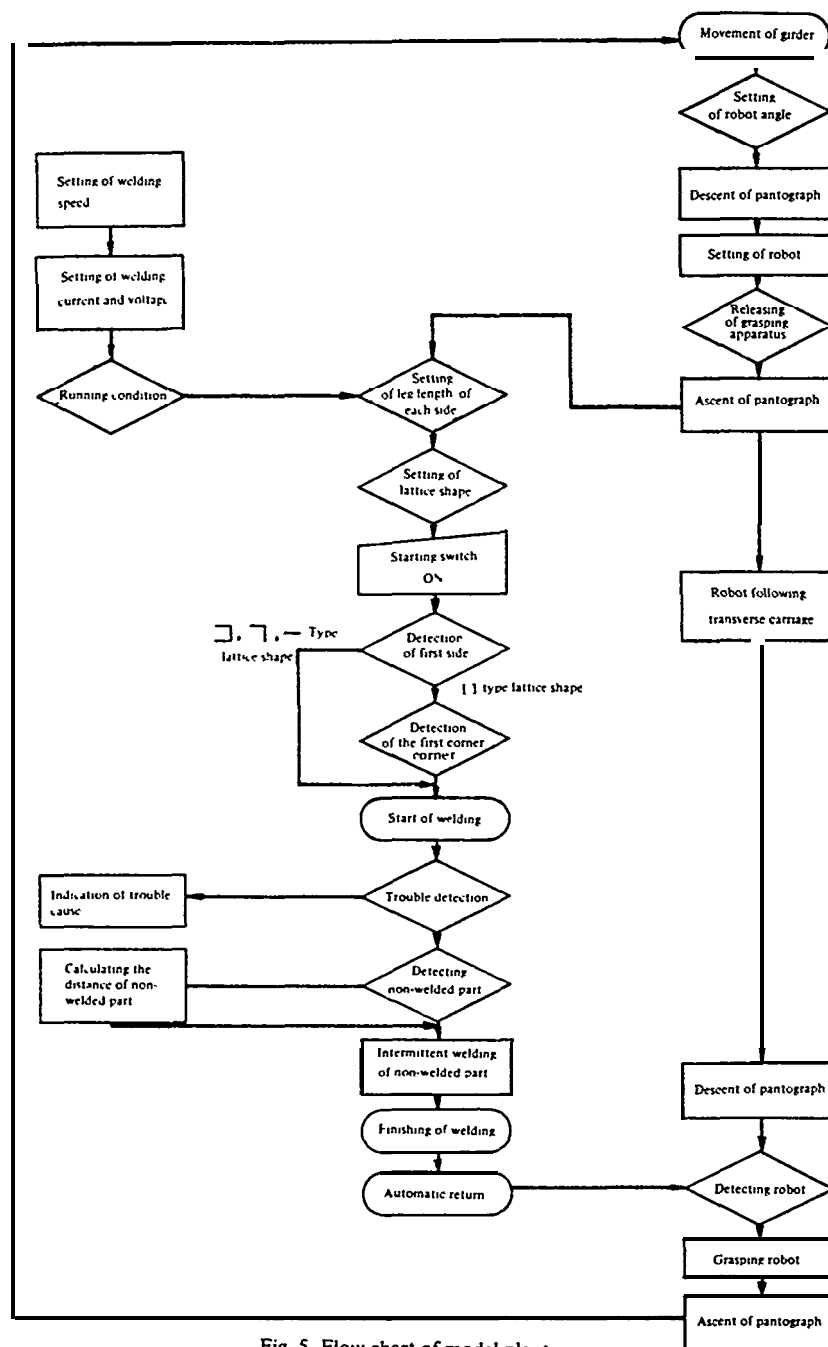

Fig. 5 Flow chart of model plant

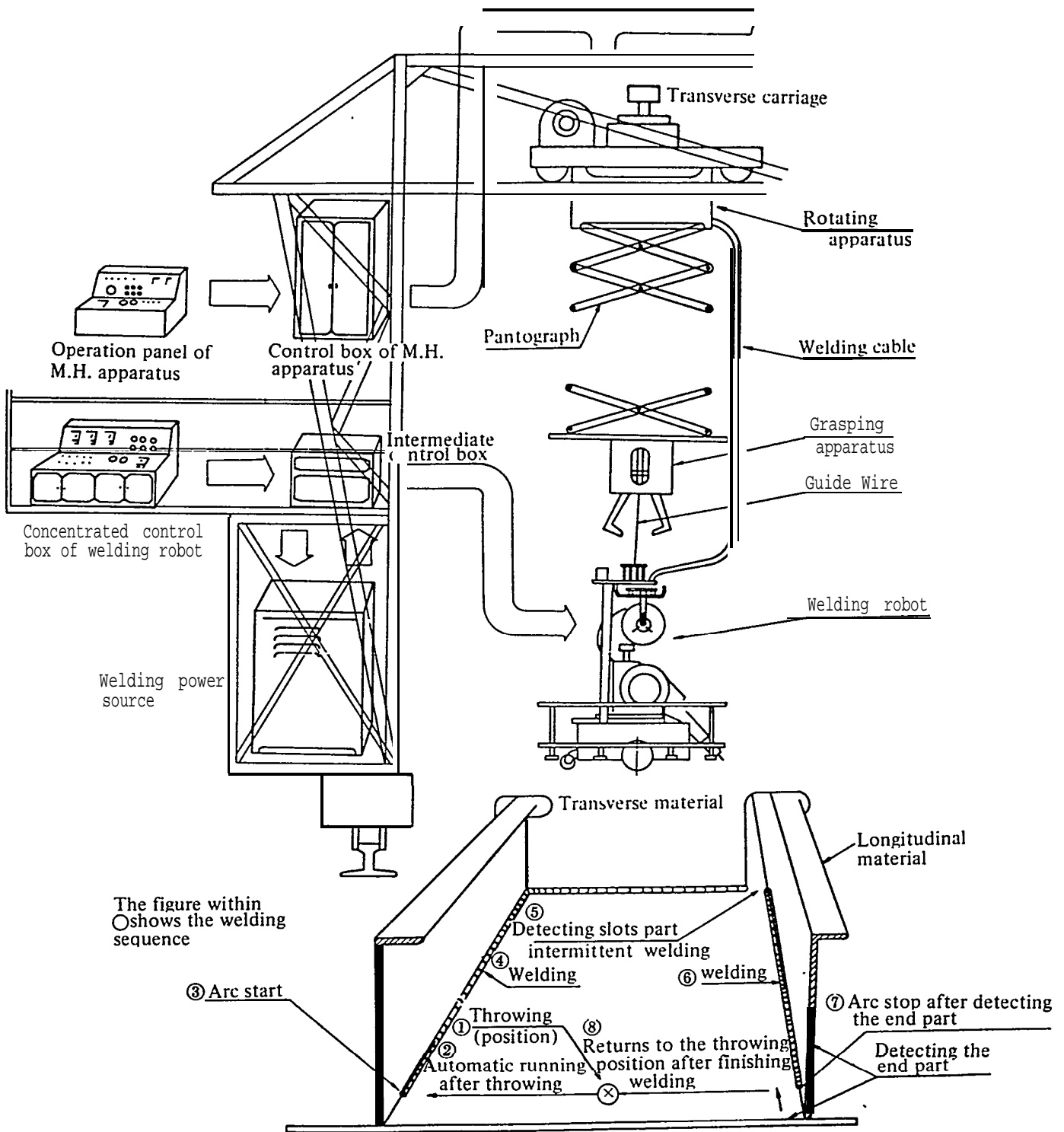

Fig. 6 Explanation of welding system of model plant

Fig. 5 and Fig. 6 show their rough sketches and the flow chart of the welding system. A model plant of this welding system is shown in Photo 1.

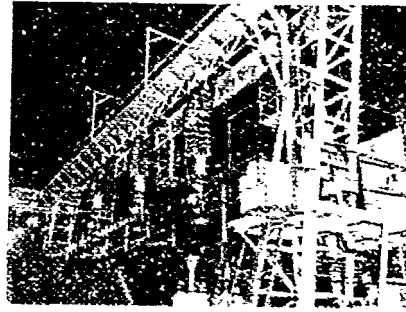

Photo 1 Appearance of model plant

4. WELDING APPLICATION FOR ACTUAL SHIP

4.1. Welding Procedure Conditions for Application to Actual Ship

Photo 2 shows application of the model plant to a panel block of a 150,000DWT tanker. Table 4 shows the procedure conditions of the robot, and table 5 shows the application standard of hull construction.



Photo 2 Application for panel block

Table 4 Procedure condition of welding robot

Shielding gas:	80% Ar + 20 % CO ₂
Wire reforming:	With two rollers
Torch inclination:	43.5 degrees
Torch advance:	11 degrees
Wire aiming position:	3.5 mm
Welding condition with 2.0 mm dia wire	
8 mm leg length:	450A, 35V, 300-350 mm/min.
6 mm leg length:	450A,35V, 400-470 mm/min.

Table 2 5 Application standard of hull construction

Item	Range of application
Slab longi. frame height	more than 60 mm
Build-up longi. frame height	more than 250 mm
Longi. frame face width	less than 120 mm (welding side of frame)
Drain hole width	less than 150 mm
Slot width	less than 185 mm
Robot carrying-in passage	more than 520 x 520 mm

4.2. Procedure Result

Horizontal fillet welding depends on accuracy of parts to be welded. Generally speaking, welding speed must be reduced to obtain the same leg length when increase of welding gap width, and non-perpendicularity of two plates to be welded will bring unsymmetry leg length and under-cut due to change of welding wire aiming position. Fig. 7 shows the results of tests about relations among welding speed, leg length and gap.

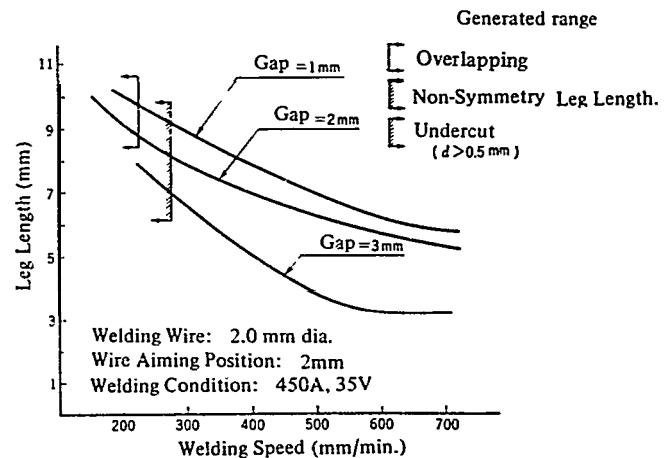

Fig. 7 Relation between welding speed and leg length

4.3 Estimating Effect

(1) The utilization factor of the robots was 65% at the application by the model plant. Fig. 10 shows efficiencies of various horizontal fillet welding devices used in most of the Japanese shipyards and of this robot with the value of 50% utilization factor.

The robot will contribute to improvement of welding efficiency with simultaneous operation of 10 - 20 robots and full automation of horizontal fillet welding of lattices.

(2) Repairings are reduced by 50 percent of gravity welding.

(3) Leftover of weld which is inevitable in gravity welding or fine wire submerged arc welding (usually about 10 percent of the total weld line) is eliminated.

(4) No skilled operator is needed and allows a single operator to take charge of plural welding machines.

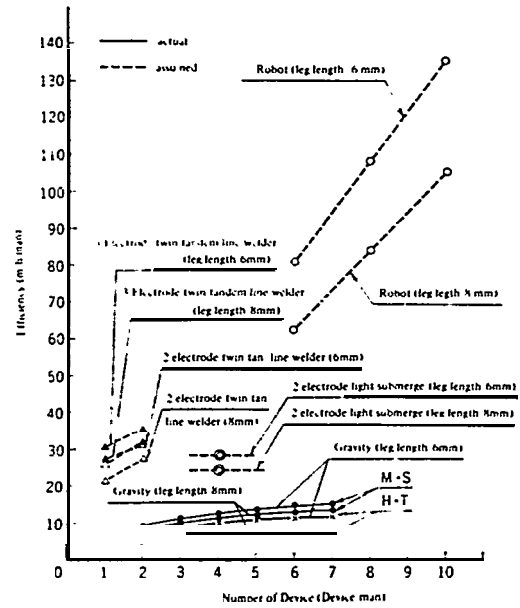

Fig. 10 Comparison of efficiency between various horizontal fillet welding machines

PART II

Automatic Hull Subassembly Machine

An automatic subassembly machine devised by the M.H.I. automatically lifts, hauls, positions, and tack welds stiffening members to a conveyor-transported web plate to fabricate a deck, side, or bottom transverse of the ship web frame. Now in operation in the Koyagi Shipyard of Mitsubishi Nagasaki Shipyard and Engine Works, the automatic subassembling machine has proved a great success, raising the production efficiency and morale of workers in the subassembly process. Further improvements are being made to the method of regular welding of stiffening members.

1. INTRODUCTION

Web frames in the cargo tanks of oil tankers consist of deck, side, and bottom transverses and constitute very important hull structural members. Placed at intervals of about five metres in the longitudinal direction, the web frames strengthen the ship hull transversely at the deck, side, and bottom. The deck, side, and bottom transverses are each made up, principally, of a web plate and a face plate and reinforced with stiffeners, brackets, etc. The process of fabricating these transverses is called the subassembly process, which may be generalized as consisting of:

- (1) Positioning and fitting up web plates
- (2) Joining the web plates by butt welding
- (3) positioning and tack welding stiffeners and brackets to the web plate
- (4) Positioning and tack welding the face plate to the web plate
- (5) Regular welding of the stiffeners, brackets, and face plate to the web plate to form a transverse
- (6) Turn-over of the transverse
- (7) Positioning and welding piece parts to the reverse side of the transverse.
- (8) Transportation of the completed transverse to the next assembly process.

Hauling, positioning, and welding in the subassembly process has traditionally relied mostly on physical labour, assisted by lifting cranes. With the advent of very large oil tankers, however, even one transverse fabricated in the subassembly process now measures about 25-30m in length and 5-8m in width and weighs as much as 25-30 tons. Stiffening members fitted to such a transverse are also very large, with some brackets weighing almost a ton a piece. All this makes the manual handling of transverse components difficult and hazardous. This being so, the weight

of transverses fabricated amounts to about 7000 tons in total per ship. Improvement of production efficiency is therefore as important a consideration as the safety of work. Also, a great amount of welding fume produced in the subassembly process demands serious attention. Accordingly, vigorous efforts have been made by the shipbuilding industry to find solutions to all these problems. The results of the efforts are improvements of production facilities and methods of fabrication, such as extensive use of the conveyor system, welding by the onesided submerged-arc process, mechanised or automated handling of stiffening members and face plates, adoption of the submerged-arc fillet welding process specifically to reduce the welding fume, etc. Of these improvements, the most worthy of note is the development of subassembling machines which automatically position and tack weld stiffening members to the web plate. In fact, the subassembling machines have broken the bottleneck created by limitations of the crane-assisted manual handling of transverse components. This Paper concerns an automatic subassembling machine which, is now in successful operation in the Koyagi Shipyard of Mitsubishi Nagasaki Shipyard and Engine Works.

2. OUTLINE OF MITSUBISHI'S AUTOMATIC SUBASSEMBLING MACHINE

2.1 Basic design concept

The basic design concept adopted in devising the automatic subassembling machine included:

- (1) The machine would be stationary while the web plate would be fed into the machine by a powered roller conveyor.
- (2) The machine would be designed to be capable of handling, principally, the large number of stiffening members which were located at right angles to the edge of the web plate; those which were slanted in relation to the edge of the web plate would be fitted along with the face plate in the subsequent subassembly stage.
- (3) The machine would be designed to complete an operational cycle in 2 min, having due regard to the optimum work load to be handled in the subsequent subassembly stage and also to the total amount of production to be achieved in the subassembly process as a whole.

- (4) The machine would be equipped with platehandling magnets to lift, haul, position, and hold a stiffening member on the web plate. The magnets would be capable of exerting a force of attraction 3-10 times as great as the weight of the stiffening member to be handled, and would serve as permanent magnets in the event of power failure to prevent the stiffening member from dropping. Also, the current in the magnets would be reversible for the efficient release of the stiffening member from the magnets. The magnets to lift and haul the stiffening member would be fitted to a part carrier, which would be designed to travel on a pair of bridge girders at a speed of 20 m/min to lessen the momentum of the carrier motion at the start and stop, with this carrier travel time being made compatible with the cycle time of the machine operation.
- (5) The machine would have a set of welding heads of the type which deposit welds using the fillet of the stiffening member and web plate as a guide.
- (6) The machine would be designed to be capable of a full automatic operation except for the minimum manual attention of depressing start and tack weld push buttons. However, to spare the machine operator the monotony of work, the machine would intentionally be made to leave some room for manual attention, such as a slight manual adjustment before the start of tack welding and also the manual tack welding from one side.

2.2 Construction

The automatic subassembling machine consists of the following principal components, as shown in Fig. 1.

Sliding part rack

Part carrier with an extendable head equipped with a set of circular plate handling magnets

Pair of bridge girders with carrier tracks on them

Part holder equipped with a set of circular plate-holding magnets

Numerical-controlled part positioner

Slot-sensing photoelectric tube

Set of bottom plate-holding magnets

Set of automatic welding heads for tack welding

2.3 Principle of machine operation

Operation of the automatic subassembling machine and that of the powered roller conveyor are completely coordinated. Stiffening members are placed on the sliding part rack in prearranged order. The web plate is fed into the automatic subassembling machine by the rollerconveyor, and the photoelectric tube built into the machine senses the presence of a slot for the longitudinal in the web plate to halt the roller conveyor. The part carrier picks up a stiffening member from the part rack and travels on the bridge girder to haul the stiffening member until it stops above the web plate at the right position where the stiffening member is to be lowered for tack welding. The carrier head then descends with the stiffening member to the level of the part holder until the stiffening member becomes sandwiched between the carrier head and part holder which are designed to close the distance in between, allowing a minimum of necessary free play for the stiffening member to move axially. Power for the part-carrier magnets is then cut off to permit the stiffening member to drop under its own weight on to the web plate. Though the stiffening member as dropped on to the web plate still remains sandwiched between the carrier head and part holder and is therefore accurately positioned, the numerical-controlled part positioner finally adjusts the distance between the end of the stiffening member and the edge of the web plate. The part-holder magnets and bottom plate-holding magnets are then energised to hold the stiffening member firmly in place for tack welding, and the carrier head ascends and the part carrier retreats. The stiffening member is tack welded to the web plate by the CO₂ gas-shielded-arc process. With the stiffening member tack welded and released from the hold of the part-holder and bottom plate-holding magnets, the web plate is moved forward by the roller conveyor until the photoelectric tube senses the presence of the next slot in the web plate. All these operations are carried out automatically except for the manipulation of the start and tack weld push buttons on the control console.

3. WORK IMPROVEMENTS ACHIEVED BY USE OF THE AUTOMATIC SUBASSEMBLING MACHINE

3.1 Improvement of productivity

As a result of the use of the automatic subassembling machine, eight platers are now required to handle and tack weld to the web plate the stiffening members and face plate as against thirteen who used to work full time to do the same job, while the amount of production per month of transverses increased to 4000 tons from 1600 tons in steel weight. In terms of length, transverses produced per day increased to 220 m from 90 m, or to 28 m from 7 m per plater per day.

3.2 Improvement of work accuracy

Since longitudinals are to be passed through the transverse by way of slots in its web plate, the distance between the end of each stiffening member and the edge of the web plate should be accurately controlled to the specified value in tack welding. As can be seen from Fig. 2, the accuracy of the positions of the tack welded stiffening members in relation to the edge of the web plate was **improved to ± 2 mm** by use of the automatic subassembling machine, as against the -3 to + 4 mm formerly obtained by manual work.

4. CONSIDERATIONS AND FUTURE IMPROVEMENTS

- (1) As compared with the traditional method of fabrication in which stiffening members were lifted, positioned, and tack welded one by one to web plates manually with the aid of an overhead travelling crane etc., the use of the automatic subassembling machine greatly increases the efficiency, accuracy, and safety of shop work.
- (2) Installed about two years ago, the automatic subassembling machine has since been in operation without any particular difficulty, which bears witness to its high reliability.
- (3) Though the existing automatic subassembling machine is somewhat limited in its motion, being able to tack weld the stiffening member only at right angles to the edge of the web plate, the second machine now under development is designed to be capable of rotary motion so that the stiffening member can be tack welded at various angles to the edge of the web plate.

- (4) As part of the improvement of the subassembly process by use of the automatic subassembling machine, it is considered necessary to use the submerged-arc fillet welding machine instead of the existing gravity welding machine for regular welding of stiffening members and face plates to the web plate to reduce the amount of welding fume. The submerged arc fillet welding machine produces far less fume than the gravity welding machine but offers little gain in efficiency. As a solution to this problem a device which automatically controls the operation of the welding head of the submerged-arc fillet welding machine has been developed. Shown in Photo. 2, the submerged-arc fillet welding machine with this control device has already been successfully tested in the shop.
- (5) Where the floor space is a limiting factor a combination of one subassembling machine and two conveyor lines will be possible to ensure the capacity operation of the machine. The arrangement will also offer the advantage of being able to position and tack weld stiffening members to a web plate whether the web plate has slots on its right or left side in relation to the machine.

5. CONCLUSION

The use of such a new subassembling machine and welding machine does not automatically lead to improved production in the subassembly process. Shop workers who operate these machines are an important factor to consider. The psychological effects of the machines on shop workers were, therefore, carefully weighed, and platers and welders were encouraged to participate in the development of the machines from the beginning. Also, the necessary training was provided for them to become familiar with the machines. It is believed that all this made for the successful application of the automatic subassembling machine in the subassembly process.

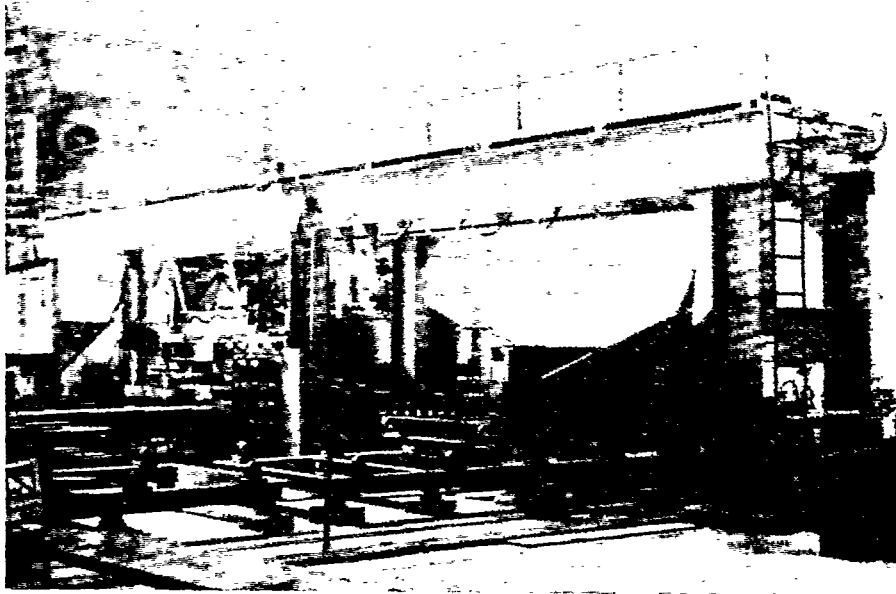

Photo. 1 General view of the machine

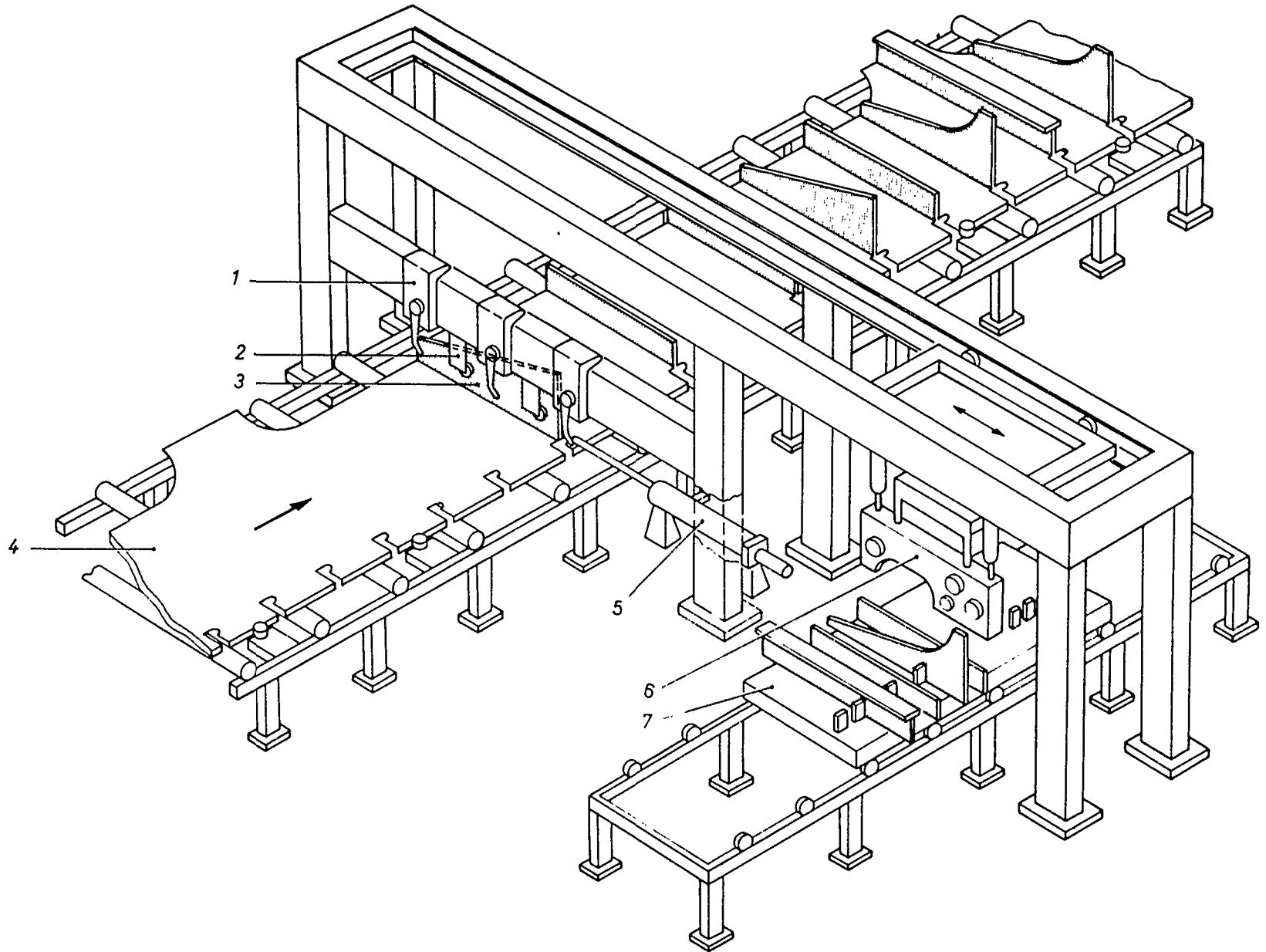
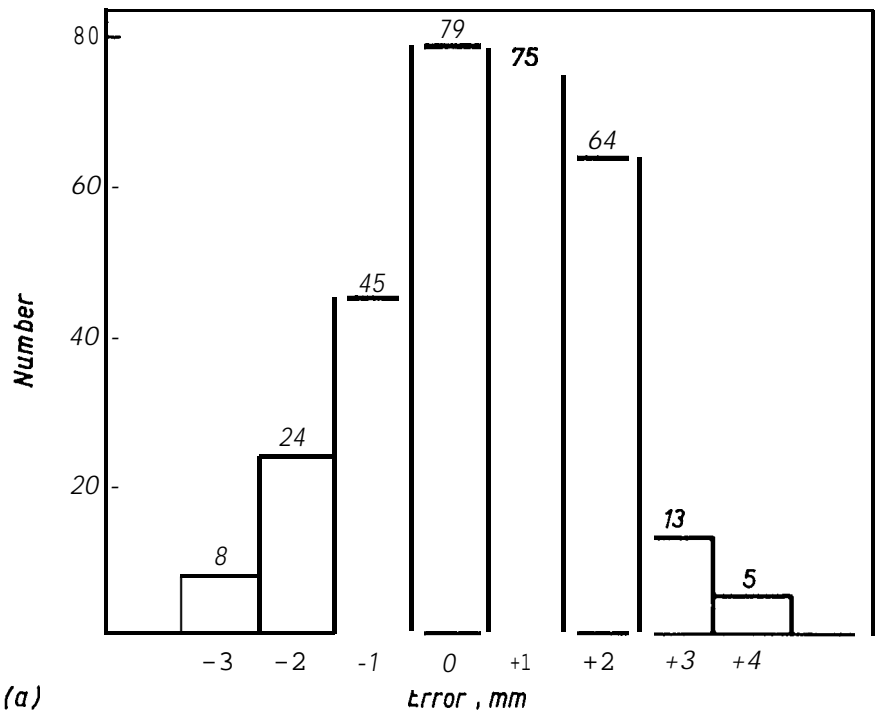
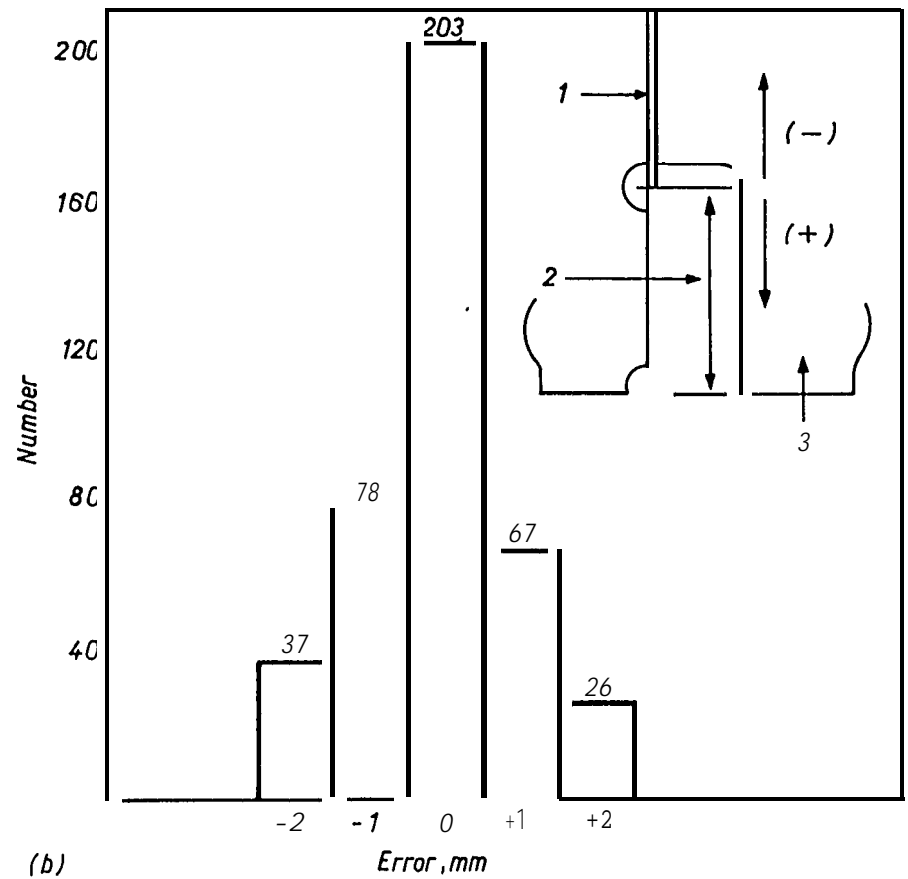
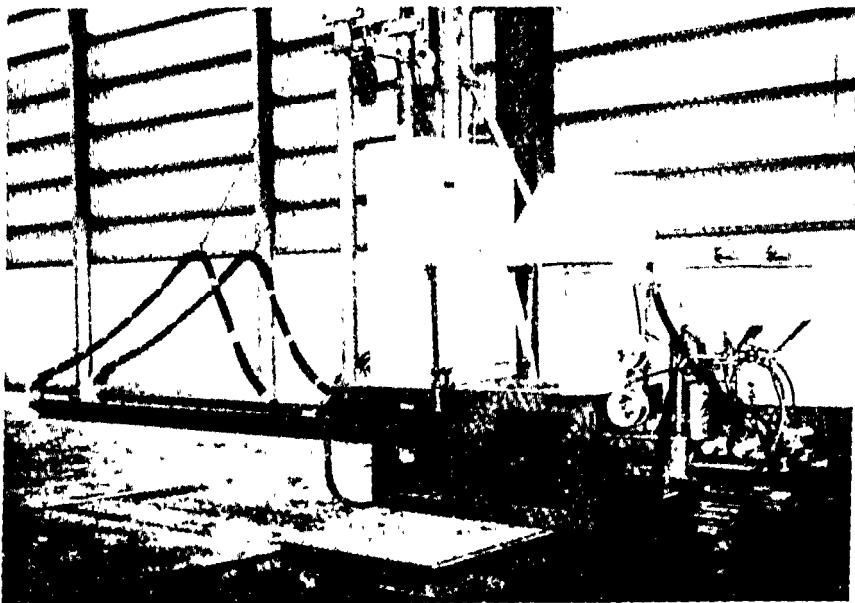

Fig. 1 Construction of automatic subassembly machine. 1—welding head; 2—part holder; 3—bracket underfitting; 4—web plate; 5—part positioner; 6—part carrier; 7—sliding part rack



(a)



(b)

Fig. 2 Comparison of accuracies with which stiffening members are fitted: (a) manually: $N=313$; $x=+0.463$; $\sigma=1.467$, (b) mechanically: $N=411$; $x=-0.08$; $\sigma=0.98$. 1—bracket stiffener; 2—specified distance; 3—web plate

Photo . 2

Submerged-arc fillet welding machine with automatic control device

PART III

Centrally Controlled Pipe Processing System

1. OUTLINE :

This system centrally controls as well as automates various phases such as fabrication, assembly and handling of small and medium-sized straight pipes in pipe shops.

Pipes to be fabricated are taken out of pipe racks where pipes of various kinds are stored, and cut into required lengths. After selection of the required flanges from flange racks, positions of the bolt holes in the flanges are adjusted, and then the pipes and flanges are tack-welded, prior to permanent welding. When finishing work on the flange surfaces has been completed, the pipes to be bent are separated from the others. The system includes a minicomputer which centrally controls as well as provides operational information inputs, to individual controllers which function solely for their corresponding individual processing machines. The latter perform their functions in accordance with instructions transmitted from their respective controllers. Incidentally, each processing machine has an input function of its own as backup, so that it is capable of handling unscheduled pipes which are not registered on the input tape of the system.

2. FEATURES :

- 1) Conventional method required about 9 workers for these works. With this system 3 workers will be able to carry out these works. Since all phases of work are fully automated, special skill or judgement on the operator, indispensable in conventional manual processing methods, is not necessary.
- 2) This system can stock processing pipes in spaces between processing machines and greatly improve efficiency with parallel operation of the machines.
- 3) Designed average processing time for one piece is approximately 3 min.

Note: This machine is now on test trial.

3. SYSTEM CONFIGURATION :

The system is a fully automated line regulated by a concentrated control unit to perform all phases of operation from taking out of the piping materials, cutting, flange installation, and all the way through to completion.

----- Note: The scope of the equipment is within this line.

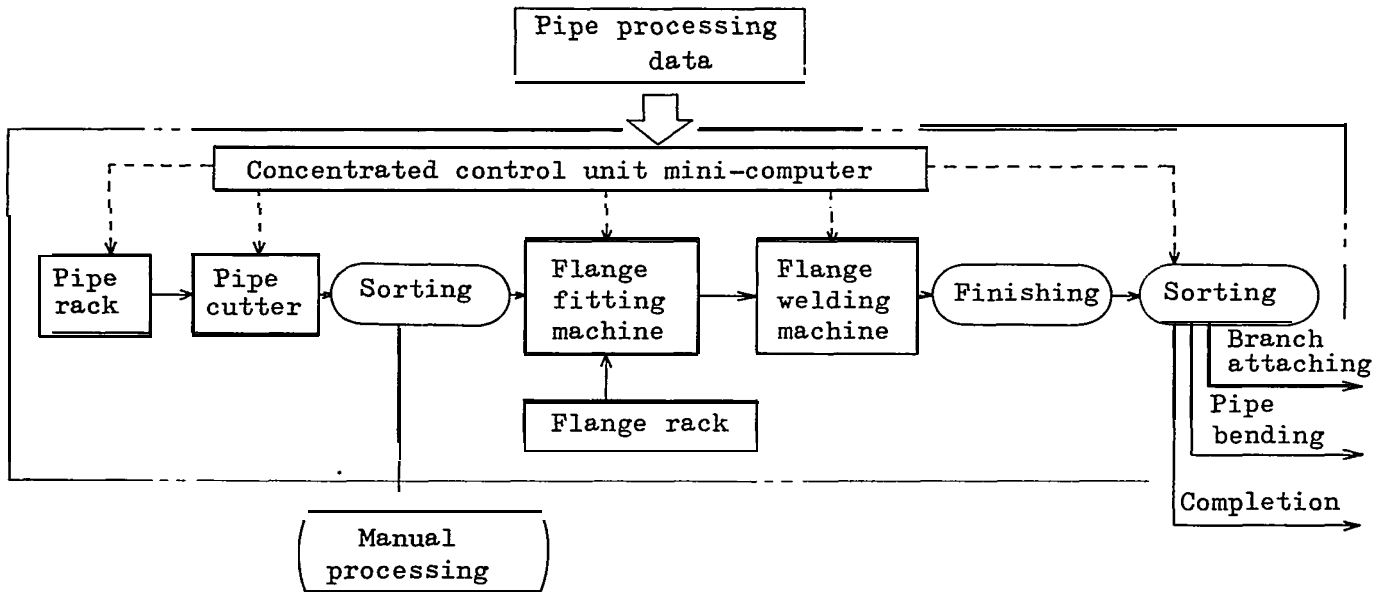

Fig. 1. Flow chart of the system

Following picture shows the layout of machines and devices included in this system.

Practically, the layout should be completed in consideration of all factors concerning pipe shop.

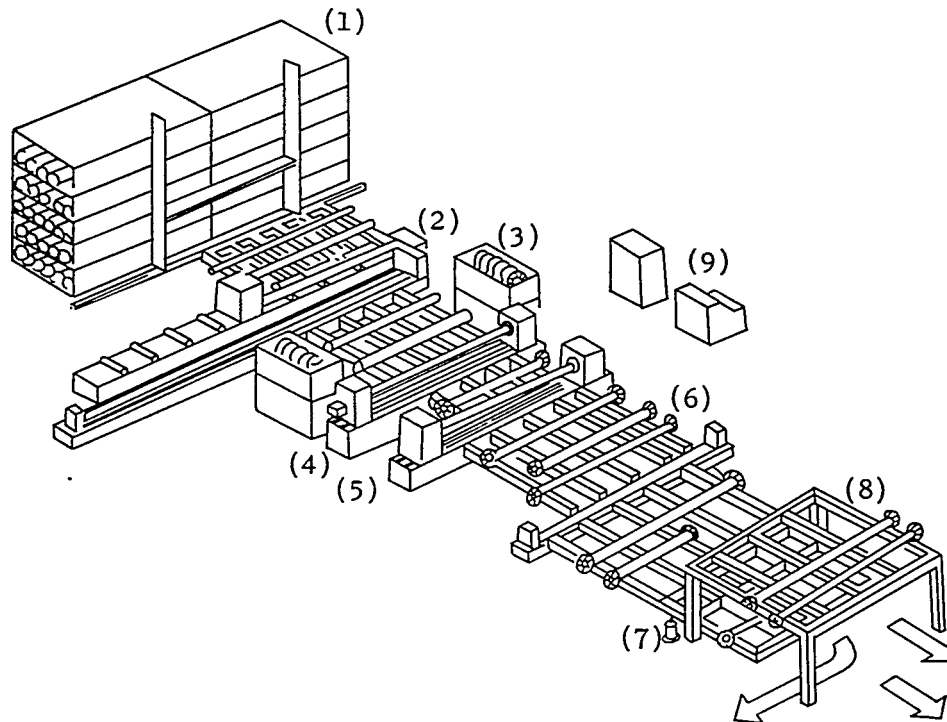

Fig.2 Bird's-eye view of the system

- | | | |
|----------------------------|----------------------------|-----------------|
| (1) Pipe racks | (2) Pipe cutter | (3) Flange rack |
| (4) Flange fitting machine | (5) Flange welding machine | |
| (6) Flange finishing table | (7) Pipe sorting device | |
| (8) Pipe skids | (9) Control console | |

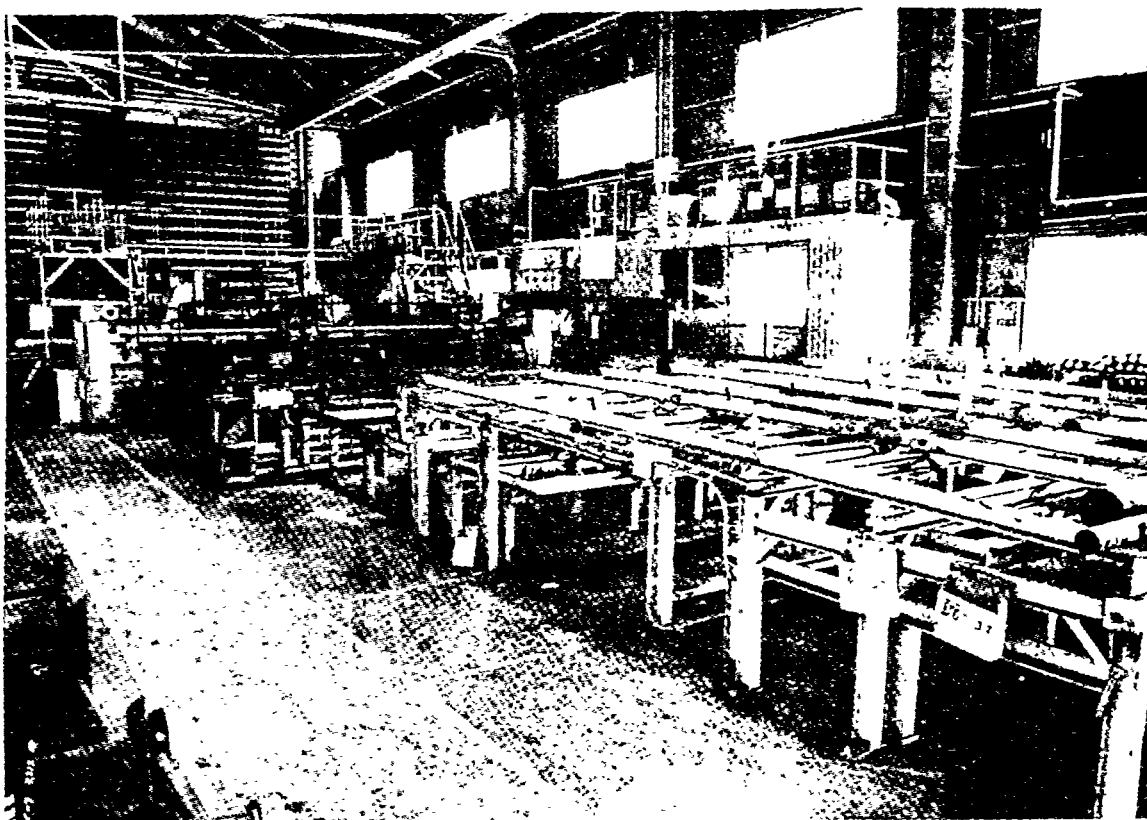

Photo 1. General view of the system

PARTICULARS

Pipe rack

Rack	2 rows x 17 levels
Pipe loader and unloader	each 1 set

Pipe cutter

(1) Nominal diameter of the pipe possible to be cut	40 - 200mm
(2) Wall thickness possible to be cut	1.5 - 30mm
(3) wall thickness possible to be subjected to bevel preparation	4.5 - 15mm
(4) Length of the original pipe	2,000 - 5,500mm

Flange fitting machine

In accordance with the instruction from the central processing unit, the machine automatically receives the pipes and flanges, inserts the pipe into the flange and performs tack - welding.

(1) Processed steel pipe

Nominal diameter	40 - 200mm
Length	1,500 - 5,500mm
Wall thickness	3.5 - 12.7mm

(2) Flange

Nominal pressure	5 kg/cm ² , 10 kg/cm ² , 16 kg/cm ²
------------------	--

Flange welding machine

By means of the central processing unit, flanges are welded both internal and external surfaces at the same time.

Pipe and flange possible to be welded are same in case of Flange fitting machine.

Pipe sorting device

At the final sorting stage in way of pipe skids, air cylinders are provided for lifting of skid and operation of gate.

Central control unit

Mini - computer	1 set
Memory capacity	12 kW
One word length	16 bits

5. OPERATION CONTROL

5.1 Composition of Operation Control Modes

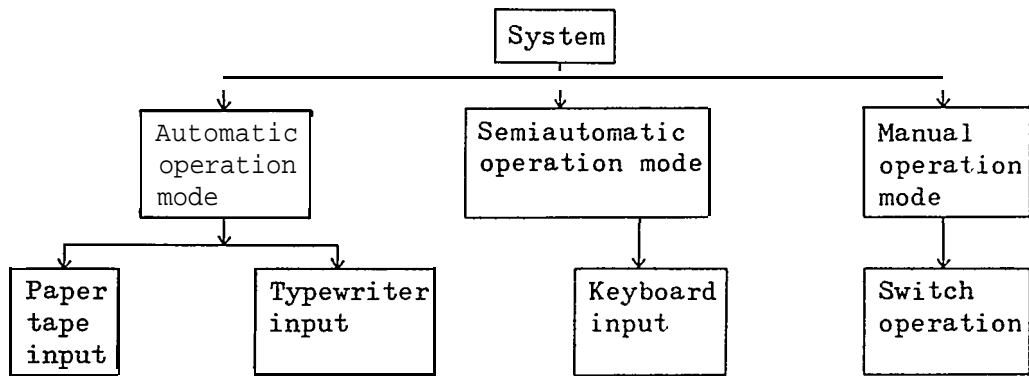

(1) Automatic Operation with Paper Tape Input

Automatic operation with N/C tape which is generated as shown in Fig. 3 is the basic operations mode of this system.

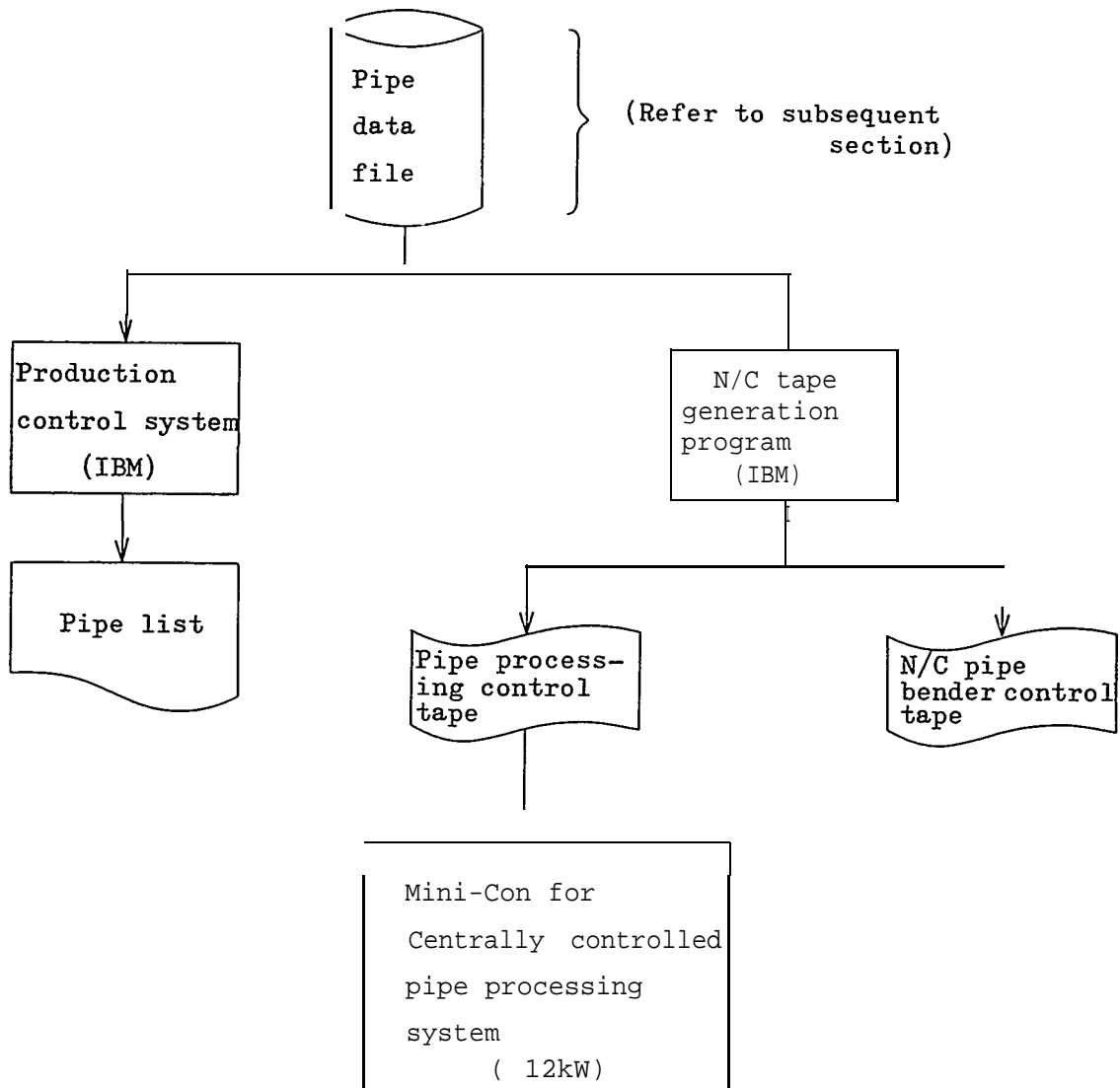

Fig. 3 N/C tape generation flow

If any one unit of equipment is switched over to the manual or semiautomatic operation mode during on-line operation, all subsequent units are released from the automatic operation mode.

(2) Automatic Operation with Typewriter Input

When the automatic operation mode is in effect, interrupt automatic operation with typewriter input is possible with respect to an unscheduled pipe requiring urgent processing.

Interruption is possible in the following two positions:

Case 1 - Pipe buffer before the cutter

Case 2 - Pipe feeder after the cutter

To enter interrupt information, the pipe rack system in Case 1, or the pipe feeder in Case 2, is temporarily suspended from operation. Input data should cover all information from the pipe rack data on in Case 1 or from the flange fitting machine on in Case 2.

(3) Semiautomatic Operation with Keyboard Input

This mode is used for processing of pipes remaining on the store rack after a trouble. Semiautomatic operation with keyboard input differs from automatic operation with typewriter input in that the former can enter only the data regarding the unit of equipment involved.

(4) Manual Operation

The manual operation mode permits separate regulation of each control axis by switching. It is usually applied only for maintenance or for recovery after a trouble.

(8) Flange Welding Data

TWK OO H ± OO F O

K o o	Kind of flange (in terms of nominal pressure)
H ± OO	Rotating angle of flange bolt hole
F O	Indicates presence or absence of flange
F 0	Unflanged
F 1	Flanged at one end, welded
F 2	Flanged at both ends, welded
F 3	Flanged at one end, tack welded only
F 4	Flanged at both ends, tack welded only
F 5	Flanged at both ends, welded at one end, the other end tack welded only

6. PS/36 (N/C DATA GENERATION SYSTEM)

6.1 Outline

PS/36 is an integrated system extending from design to production stage for pipe outfitting, and is an important tool for rationalization of outfitting work. In this system appropriate pipes and valves are selected by feeding piping data picked up from detail pipe arrangement plan and the piping data are checked and corrected in reference to fabrication criteria. then piece drawing of pipe is obtained.

6.2 Features

- (1) Increase of accuracy and efficiency of fabrication and assembly work.
- (2) Saving of man-power and time of piping design.
- (3) Reliable results even by unskilled workers.
- (4) Capable of connection with production control system for outfitting work, as well as with N/C pipe fabrication system.
- (5) Easy input by designer-oriented PIPE language.
- (6) Easy expansion and modification of system by its modular configuration.
- (7) Reduction of input load by a number of standard files including fabrication practice and particulars of pipes, valves, etc.

6.3 System Configuration

- (1) Language processor
Translating input piping data coded with pipe language, and breaking-down into a series of pipe piece data (to be stored into data base).
- (2) Standard file maintenance program
Storing 'fabrication practice, particulars and patterns of pipes, valves, etc.
- (3) Drawing program
Drawing pipe lines in various forms such as projection, profile and birds-eye-view.
- (4) Pipe piece drawing program
Output of pipe lists and piece drawings.

This system can be easily connected with other systems such as production control and N/C fabrication systems through data base and can be operated on IBM/370, UNIVAC 1100, and CDC 6400 at present.

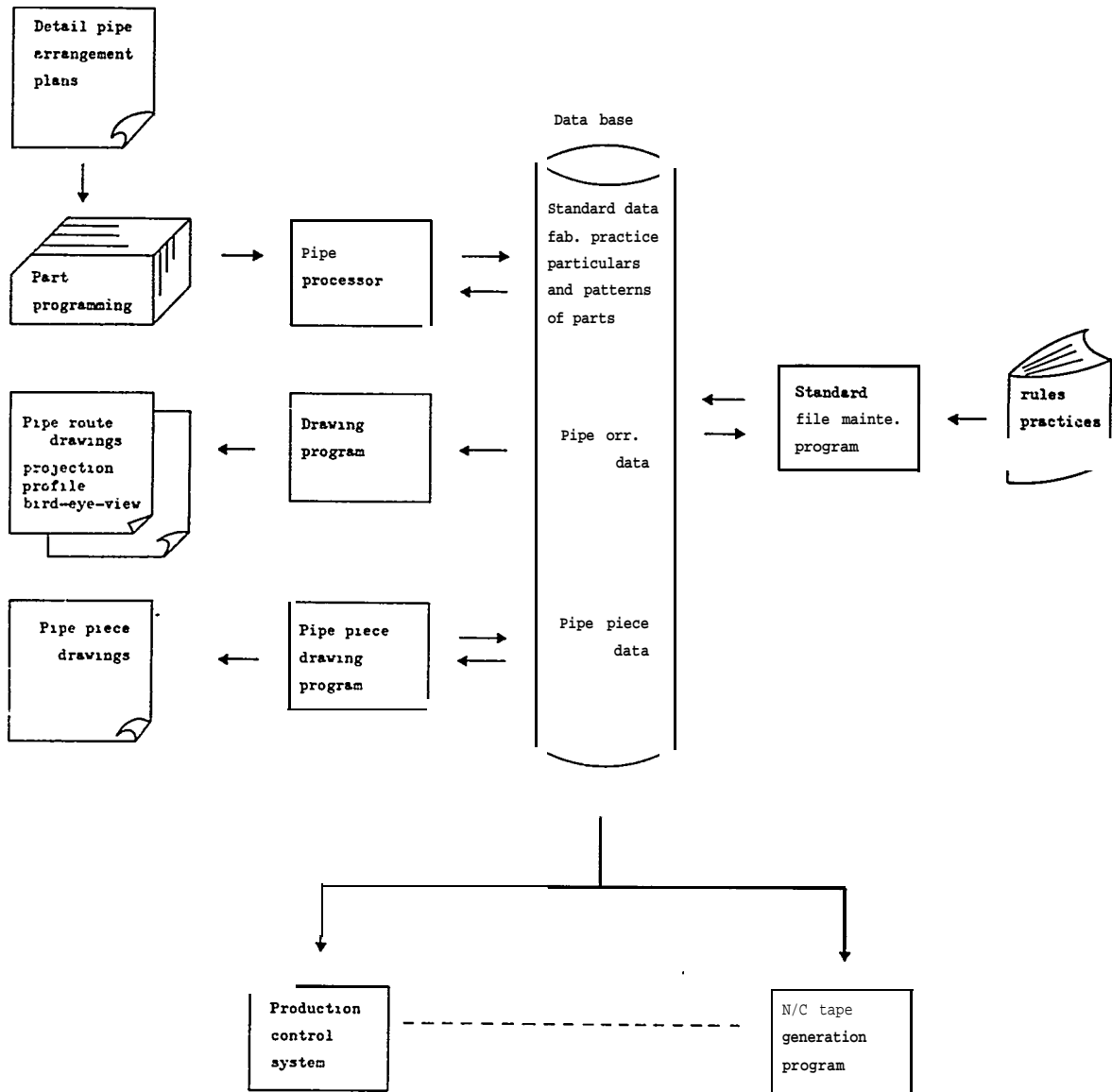

Fig. 4 N/C Data generation system configuration

Additional copies of this report can be obtained from the
National Shipbuilding Research and Documentation Center:

<http://www.nsnet.com/docctr/>

Documentation Center
The University of Michigan
Transportation Research Institute
Marine Systems Division
2901 Baxter Road
Ann Arbor, MI 48109-2150

Phone: 734-763-2465
Fax: 734-763-4862
E-mail: Doc.Center@umich.edu