

SHIP PRODUCTION COMMITTEE
FACILITIES AND ENVIRONMENTAL EFFECTS
SURFACE PREPARATION AND COATINGS
DESIGN/PRODUCTION INTEGRATION
HUMAN RESOURCE INNOVATION
MARINE INDUSTRY STANDARDS
WELDING
INDUSTRIAL ENGINEERING
EDUCATION AND TRAINING

September 1981
NSRP 0008

THE NATIONAL SHIPBUILDING RESEARCH PROGRAM

Proceedings of the REAPS Technical Symposium

Paper No. 8: The U.S. Navy CAD/CAM Program Hull Structure (HULSTRX)

U.S. DEPARTMENT OF THE NAVY
CARDEROCK DIVISION,
NAVAL SURFACE WARFARE CENTER

Report Documentation Page

Form Approved
OMB No. 0704-0188

Public reporting burden for the collection of information is estimated to average 1 hour per response, including the time for reviewing instructions, searching existing data sources, gathering and maintaining the data needed, and completing and reviewing the collection of information. Send comments regarding this burden estimate or any other aspect of this collection of information, including suggestions for reducing this burden, to Washington Headquarters Services, Directorate for Information Operations and Reports, 1215 Jefferson Davis Highway, Suite 1204, Arlington VA 22202-4302. Respondents should be aware that notwithstanding any other provision of law, no person shall be subject to a penalty for failing to comply with a collection of information if it does not display a currently valid OMB control number.

1. REPORT DATE SEP 1981	2. REPORT TYPE N/A	3. DATES COVERED -	
4. TITLE AND SUBTITLE The National Shipbuilding Research Program Proceedings of the IREAPS Technical Symposium Paper No. 8: The U.S. Navy CAD/CAM Program Hull Structure (HULSTRX)		5a. CONTRACT NUMBER	
		5b. GRANT NUMBER	
		5c. PROGRAM ELEMENT NUMBER	
6. AUTHOR(S)		5d. PROJECT NUMBER	
		5e. TASK NUMBER	
		5f. WORK UNIT NUMBER	
7. PERFORMING ORGANIZATION NAME(S) AND ADDRESS(ES) Naval Surface Warfare Center CD Code 2230 - Design Integration Tools Building 192 Room 128 9500 MacArthur Blvd Bethesda, MD 20817-5700		8. PERFORMING ORGANIZATION REPORT NUMBER	
9. SPONSORING/MONITORING AGENCY NAME(S) AND ADDRESS(ES)		10. SPONSOR/MONITOR'S ACRONYM(S)	
		11. SPONSOR/MONITOR'S REPORT NUMBER(S)	
12. DISTRIBUTION/AVAILABILITY STATEMENT Approved for public release, distribution unlimited			
13. SUPPLEMENTARY NOTES			
14. ABSTRACT			
15. SUBJECT TERMS			
16. SECURITY CLASSIFICATION OF:			17. LIMITATION OF ABSTRACT
a. REPORT unclassified	b. ABSTRACT unclassified	c. THIS PAGE unclassified	SAR
			18. NUMBER OF PAGES 51
			19a. NAME OF RESPONSIBLE PERSON

DISCLAIMER

These reports were prepared as an account of government-sponsored work. Neither the United States, nor the United States Navy, nor any person acting on behalf of the United States Navy (A) makes any warranty or representation, expressed or implied, with respect to the accuracy, completeness or usefulness of the information contained in this report/manual, or that the use of any information, apparatus, method, or process disclosed in this report may not infringe privately owned rights; or (B) assumes any liabilities with respect to the use of or for damages resulting from the use of any information, apparatus, method, or process disclosed in the report. As used in the above, "Persons acting on behalf of the United States Navy" includes any employee, contractor, or subcontractor to the contractor of the United States Navy to the extent that such employee, contractor, or subcontractor to the contractor prepares, handles, or distributes, or provides access to any information pursuant to his employment or contract or subcontract to the contractor with the United States Navy. ANY POSSIBLE IMPLIED WARRANTIES OF MERCHANTABILITY AND/OR FITNESS FOR PURPOSE ARE SPECIFICALLY DISCLAIMED.

Proceedings
IREAPS Technical Symposium
September 15-17, 1981
Baltimore, Maryland

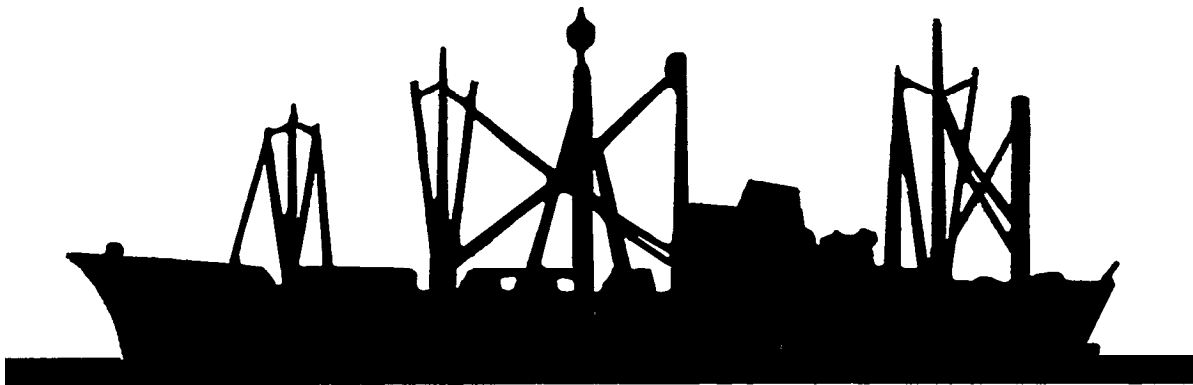

INSTITUTE FOR RESEARCH AND ENGINEERING FOR AUTOMATION AND PRODUCTIVITY IN SHIPBUILDING

IREAPS

U. S. NAVY CAD/CAM PROGRAM HULL STRUCTURE (HULSTRX)

David Helgerson
Chief, Hull Scientific Section

Eric Byler
Systems Analyst
Advanced Marine Enterprises Inc
Arlington, Virginia

ABSTRACT

This paper is a status report on the development of HULSTRX and its integration into the Navy CAD/CAM Program; it presents the implementation of the system outlined by S. Klomparens at the 1979 meeting of REAPS.

The HULSTRX Program effort is aimed at the development of a ship data base containing the locations and scantlings of all hull structural members based upon an established description of the internal and external hull geometry. The data base to be generated will be used for three purposes: (a) development of structural contract design guidance drawings; (b) dissemination of pertinent structural information to other areas of ship design such as arrangement developments, weight estimation and distributive systems backgrounds and composites; and (c) as an aid for the development of structural details, fabrication drawings, and generation of N/C data.

INTRODUCTION

This paper is an update on the development of the computer program Hull Structure (HULSTRX). HULSTRX is a computer aided design tool for representing and displaying ship structure. When complete, it will be used for both surface and submarine structure. It is being developed for the Navy's Surface Ship Structures Branch as part of the Navy's Computer Supported Design (CSD) Project.

The Navy has recently changed the management of Computer Aided Ship Design and Construction (CASDAC). The early stage or in-house design support will be directed from NAVSEA 03R under the Computer Supported Design (CSD) Project. CSD will be responsible for the development of computer aids used in the design of Naval ships. The intent is to develop an integrated system from early stage design through feasibility, preliminary and contract design. Ship Technical Programs will be managed from NAVSEA 90M and will be supported using Manufacturing Technology funding.

Two (2) years ago, Mr. Stephen Klomprens presented a paper at a REAPS Technical Symposium entitled "HULSTRX-A CASDAC Computer Aid for Hull Structural Contract Design." In this paper, Mr. Klomprens outlined the framework for the computer program HULSTRX and described the objectives for which the program was being developed. This paper is an update of the continuing efforts to develop the program, HULSTRX.

It is the objective of this paper to:

- Review the desired capabilities for HULSTRX within the Navy's CSD system;
- Demonstrate the capabilities which the program presently affords the structural designer; and finally,
- To discuss the ongoing and future development of the program.

BACKGROUND: THE NAVY CSD SYSTEM

The Navy's CSD project is an effort to develop and use computer generated data to support the design community. It is a combination of several computer design tools which access a set of common data bases during the ship design process. To insure that designers involved in one facet of the design process coordinate their efforts with other design efforts, the concept of the Design Geometry Library (DGL) was established.

Essentially, the DGL represents the description of the ship design at any given time and is subdivided into the principal design areas of hull form, arrangements, and structures. Figure 1 depicts the Navy's CSD system and the role of the DGL. The importance of the DGL to this discussion is that the DGL serves as the primary interface between the structural design programs and the other computer programs used in designing a ship.

Figure 1 also demonstrates the role of HULSTRX within the Navy system. The hull form portion of the DGL contains a description of the hull form and is created primarily by the program HULDEF." The arrangements portion of the DGL, created by DEKOUT*, contains the locations and descriptions of decks, bulkheads, and major openings. HULSTRX draws upon data within these two data bases and creates the structural portion of the DGL. The structural portion of the DGL contains the location and description of structural members which lie on the hull form, decks, bulkheads, and other surfaces. This portion of the DGL can then be used in many ways:

- As input for other structural design programs;
- As a basis for computer generated structural drawings;
- As a design deliverable in and of itself.

* For convenience, Appendix A provides brief descriptions of Computer programs which develop the DGL or use the DGL as input for calculating their specific output.

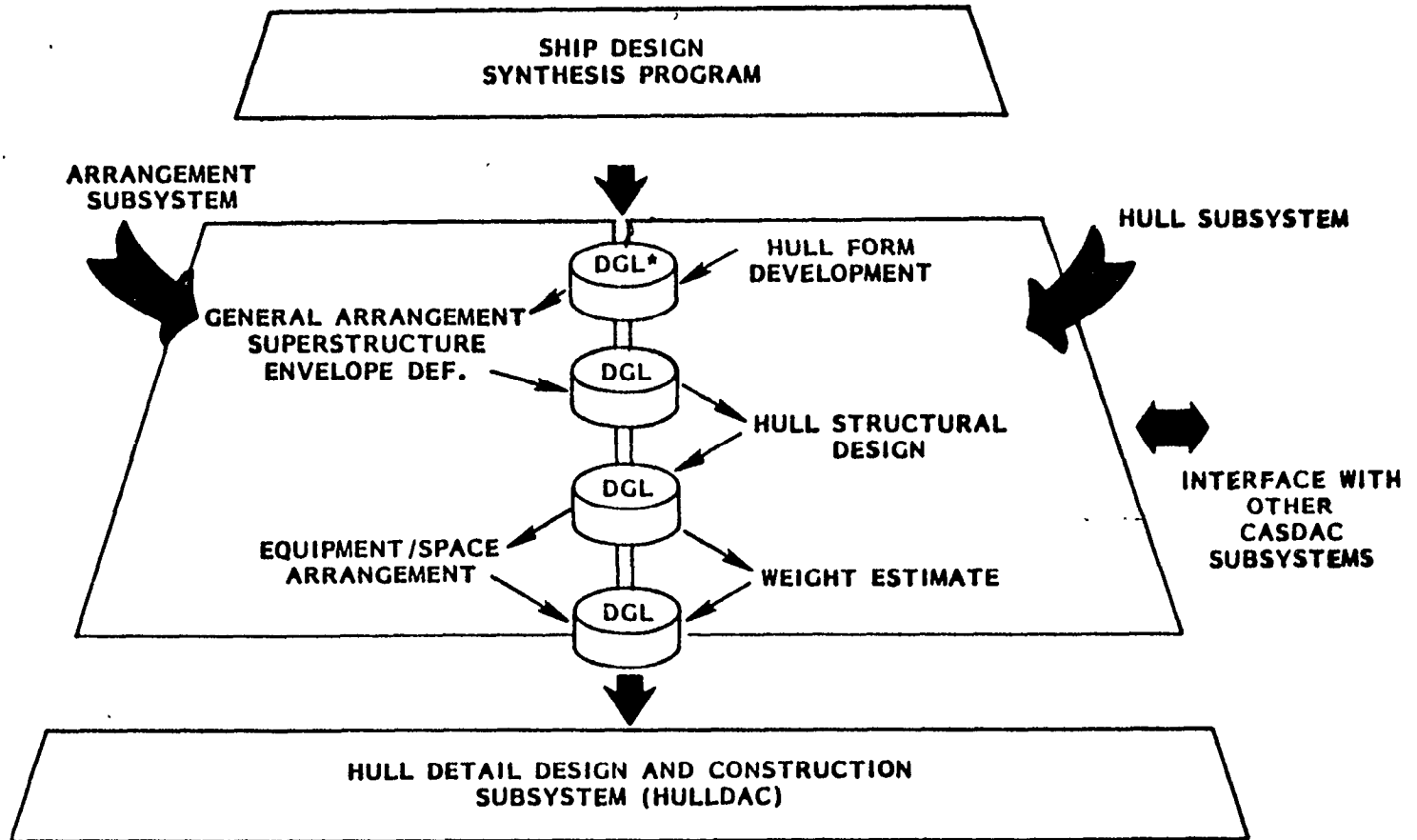

*DGL: DESIGN GEOMETRY LIBRARY

Figure 1 - The Navy CSD System

HULSTRX has been subdivided into two parts for effective development. The first stage of the program has been directed toward defining the traces of structural members on the surface in question (e.g. deck, bulkhead, or shell). The second stage is intended to define the scantlings of each specific member (i.e., properties such as web depth, flange width, thickness, orientation to the molded surface, materials, etc.). The portion of the DGL currently developed is the structural trace file. The second stage of HULSTRX development will incorporate the structural scantling information. This paper will not address the development of that portion of HULSTRX which creates the scantlings file as this effort is being performed separately.

HULSTRX OBJECTIVES

At the conception of HULSTRX, the design deliverables to be addressed included:

1. Drawings of midship section and typical sections;
2. Deck drawings for all decks;
3. Shell expansion drawings;
4. Deckhouse or superstructure drawings;
5. Longitudinal strength study;
6. Other structural calculations.

As HULSTRX has developed, the emphasis has been redirected towards establishing the structural portion of the DGL and thus allowing the development of structural drawings. Calculations have been left to other structural design programs, such as the Structural Synthesis Design Program, SSDP. Essentially, the current objectives of HULSTRX can be summarized as follows:

1. Develop shell expansion drawings showing all structural traces, bulkheads, decks, and plating;
2. Develop deck drawings showing structural members for all decks, including superstructure and associated surfaces;

3. Develop bulkhead drawings showing structural members for all bulkheads, including superstructure and associated surfaces;
4. Develop midship and typical section drawings showing hull plating, shell stiffeners, bulkheads, decks, and associated surfaces;
5. Provide a complete data base of the structural Contract Design.

In its present form HULSTRX is operational and can meet the first three objectives. With initial input of the hull form and arrangements portions of the DGL, HULSTRX can be used by the designer to locate stiffeners and arrange plating. In batch mode, an expanded shell drawing can be developed by HULSTRX and plotted by UPLOTT (a utility drafting routine). Similarly, bulkheads and decks defined in the DGL can be complemented with structural members and plating boundaries: using UPLOTT, bulkhead and deck drawings can be produced. HULSTRX requires further development to satisfactorily develop sections: while the shell boundary can be determined, the stiffeners on the shell are not readily shown. This limitation will be bypassed with development of the second portion of HULSTRX allowing the definition of the scantlings file.

Figures 2 through 4 show examples of drawings developed using HULSTRX generated structural traces. Examination of these drawings will clearly show HULSTRX's present capabilities and also its limitations. Later, we will examine the internal mechanics of HULSTRX and identify the causes of the program exigencies.

Figure 2 is a shell expansion for a typical destroyer hull form. Note the clear presentation and the line quality. In order to generate this drawing, the operator, in a batch mode, used the hull form description and the location of decks and bulkheads contained in the DGL as input and added the structural traces. The traces are input as two dimensional traces that are converted into three dimensional traces which lie on the shell surface.

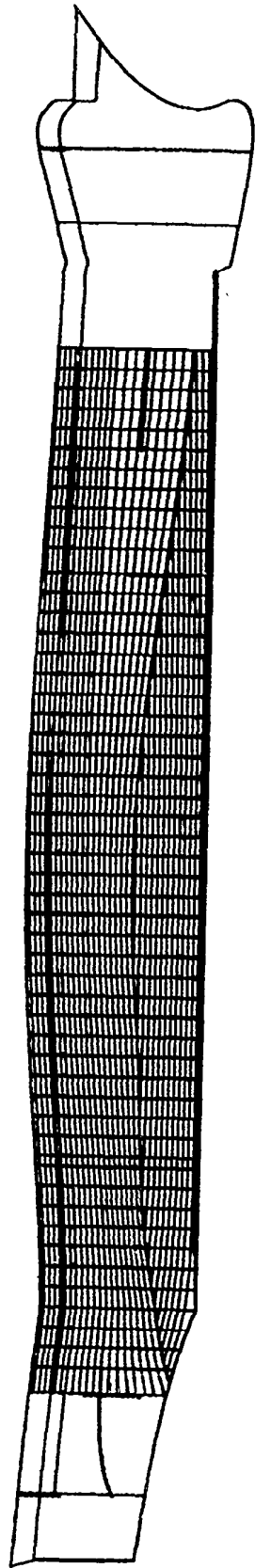

FIGURE 2. SHELL EXPANSION

Alternatively, the designer can select two existing lines, surfaces, or structural traces and input a desired number of equally spaced traces; HULSTRX would then determine three dimensional traces with the desired spacing (the equal spacing can be in terms of girth or one of the coordinate directions.). After any specific run, the designer can choose to plot the shell expansion to graphically inspect his work.

Figure 2 contains an example of one of the programs' limitations; HULSTRX is not capable at present to depict a satisfactory shell expansion of a ship which has a bulbous bow or other appendage. The shell expansion is distorted in way of skegs and bulbs because of the extra girth added by the appendage. The extra girth created a bulge in an ostensibly straight stiffener. In manual practice, the bulb and skeg are simply "tacked on" the bottom of the shell expansion. An appropriate method of handling these discontinuities is under study.

Figure 3 is an example of a deck drawing . Deck drawings can be very satisfactorily developed using HULSTRX and UPLOTT as this drawing shows. At present, the drawing lacks stiffeners which intersect the deck perpendicularly; frames are not shown where they meet the deck, nor are bulkhead stiffeners. In the case of deck drawings, this is not a significant problem as such information represents only a small portion of the drawing. It becomes a more significant problem when portraying bulkheads and sections as later figures will show.

Figure 4 is a typical bulkhead developed by HULSTRX and UPLOTT. The complexity is similar to that of the deck plan and, as stated above, the absence of perpendicular members is more apparent. A resolution for this limitation is under development.

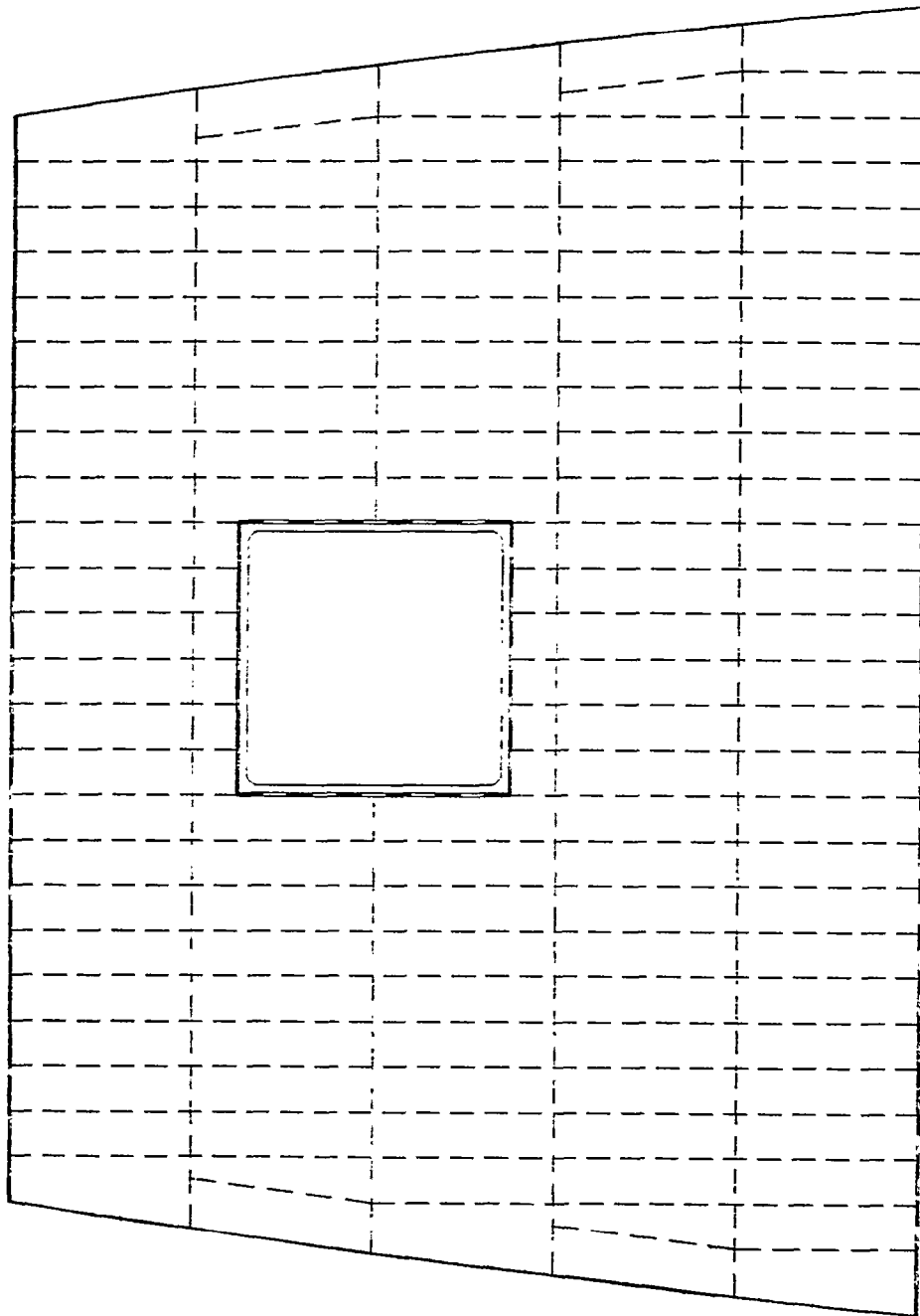

Figure 3 - Deck with Stiffeners

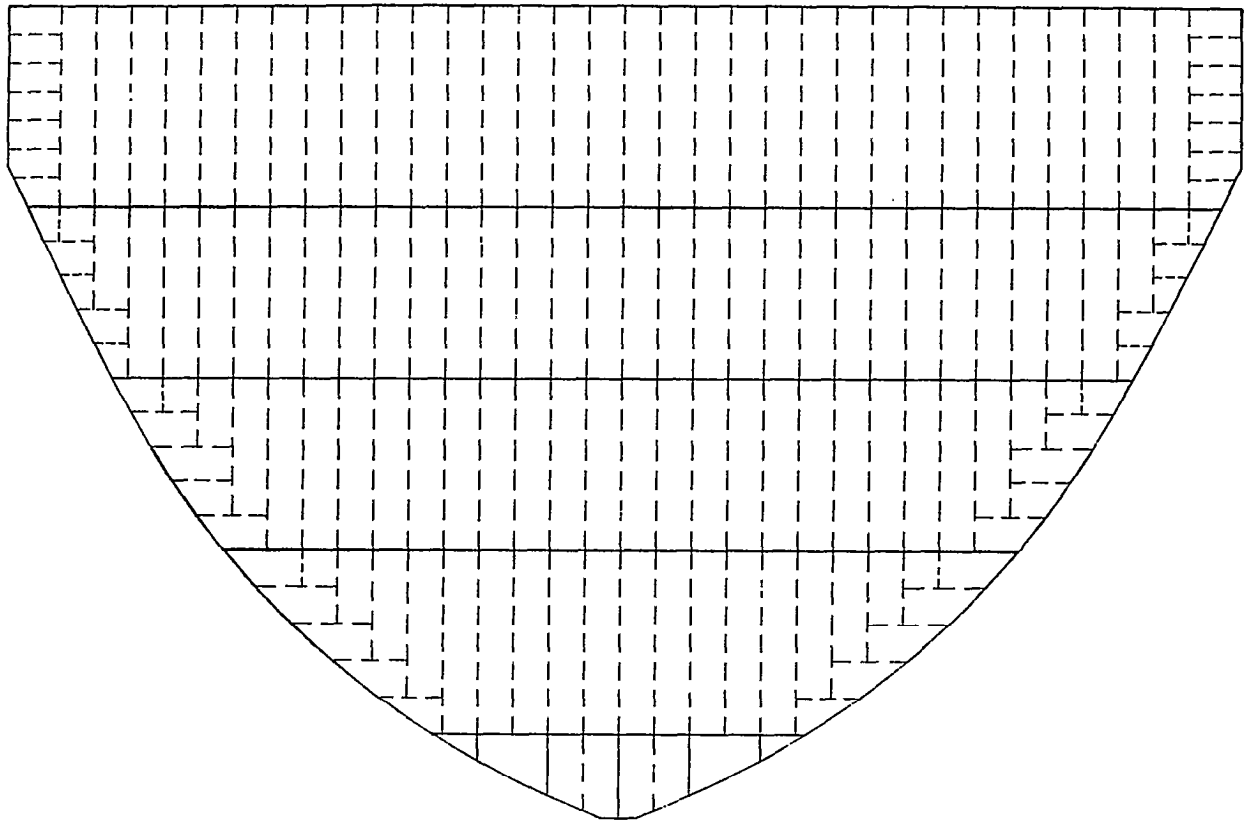

Figure 4 - Transverse Bulkhead

OPERATIONAL ASPECTS

A flow chart showing the operational steps of HULSTRX is shown in Figure 5. Some of this material has been presented in Reference 5. Essentially, the designer begins with a mathematical description of the ships surfaces and a desired scantling configuration. The designer transforms the scantling configuration into input data which are sets of points, or sets of points and tangents. After HULSTRX operates on the input, the designer reviews the output and modifies the input data until he is satisfied with the representations. Several runs may be required to achieve the desired detail; performance should improve with experience.

HULSTRX adds traces of structural members to a working file for each surface during execution. Once all traces are added to a surface, the working file of structural traces for that surface is written to a revised DGL. The revised DGL file contains all the surface definition information of the original multi-surface DGL file plus the new structural traces currently being added to the surfaces being considered. Each batch run must use all current structural traces since old traces are not retained. The original multi-surface DGL file is not modified during execution and may be retained or deleted at the user's option. Only the structural portion of the DGL can be modified by the structural designer using HULSTRX.

HULSTRX performs its manipulatory functions by utilizing a temporary grid file of each surface. This temporary file is searched to determine points of intersection with the specified structural trace. The points of intersection are splined together and then faired to form a line on the surface. This new line is then written to the working surface file. Once all the traces are written for one surface and that surface is complete, the trace file is written to the revised DGL and the grid surface and working file are discarded.

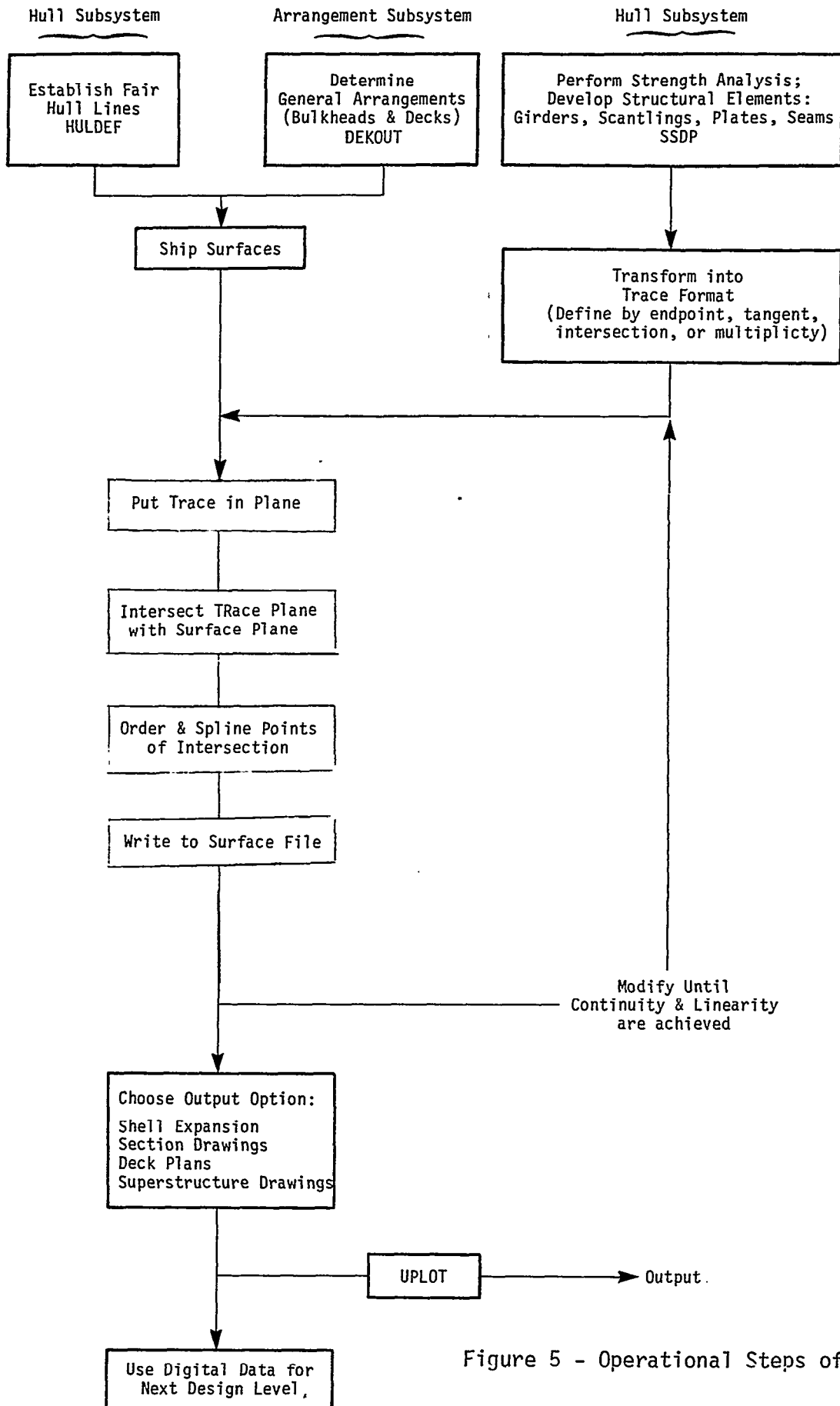

Figure 5 - Operational Steps of HLSTRX

Until a surface is complete, the working file of traces must be kept on hand in case a previously calculated trace is specified as an intersection line.

Details of the current HULSTRX development state are presented below under the categories of :

1. Design Geometry Library (DGL) structure;
2. Structural trace processing (mapping methodology);
3. Inputs to the program; and
4. Outputs from the program.

Design Geometry Library

The file structure and format of the data base that HULSTRX works with is the same as that used with HULDEF with an additional capability to handle multiple surfaces. The DGL is a sequential access file containing unformatted records. Record length is determined by the input/output (I/O) list in the read or write statement. The first record of the DGL contains the ship identifier, comprised of up to 20-characters (5A4), and the ship creation (or version) date, 8-characters (2A4). The remaining records on the DGL are broken up into surface blocks, as shown in Figure 6. Each surface block contains a 6-character surface identifier (the first record on the surface), followed by all lines on that surface. Lines are described by a 6-character identifier (3A2), line type (an integer), the number of segments in the line (an integer from 1 to 50), then the segments in endpoint/tangent form (SEGS {13,501}. (Only the last 12 values of each segment actually are present.) The sentinel for the end of the surface block is a blank line identifier. The sentinel for the end of the DGL is a blank surface identifier.

The naming conventions for the 6-character surface and line (trace) names are presented in Table 1. The names start with a mnemonic string of 2 or 3-characters, and are filled out to 6-characters by the program user

or internally generated by the program. Some of the names may have an implied decimal point location to allow the trace name to contain a numerical position. This information is optional for structural traces and is currently only used by HULDEF. The names assigned to lines are used to define the line type code. Each line type code is drawn with a different kind of line.

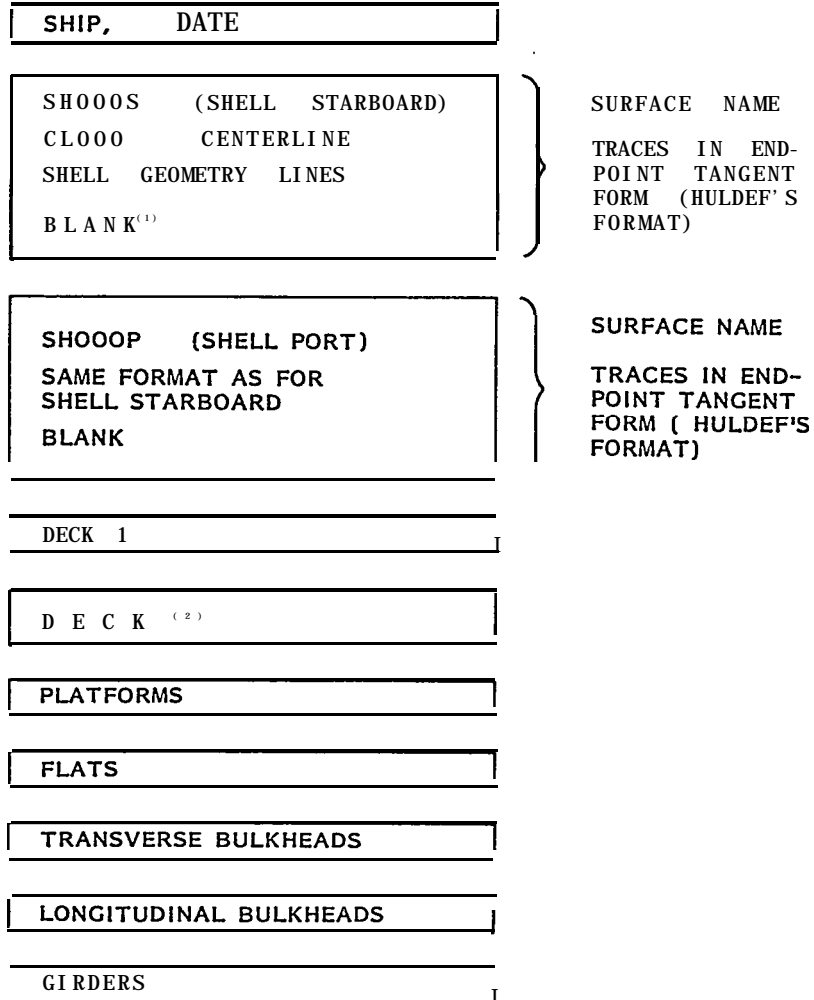

NOTE:

- (1) BLANK TRACE NAME INDICATES END OF SHELL SURFACE
- (2) EACH DECK, OR ANY OTHER CATEGORY OF SURFACE, MAY BE REPRESENTED AS A INDEPENDENT SURFACE SUB-FILE.

FIGURE 6 - DESIGN GEOMETRY LIBRARY DATA REQUIRED AS INPUT TO HULSTRX

TABLE I

<u>SHELL GEOMETRY TRACES</u>	<u>IDENTIFIER</u>
FORM LINE	
GIRTH LINE	IS-----
CONTROL LINE	C-----
DISPLAY LINE	D-----
STATION	STA---
FRAME	...
WATERLINE	WL-----
BUTTOCK	BT-----
DIAGONALS	DI-----
<u>ARRANGEMENT TRACES</u>	
TRANSVERSE BULKHEAD	TB-----
WEB FRAMES.	WF-----
DECK	DK-----
PLATFORMS	PF-----
FLATS	FL-----
LONGITUDINAL BULKHEAD	LB-----
SKEW BULKHEAD	SB-----
JOINER BULKHEAD	JB-----
<u>STRUCTURAL TRACES</u>	
STIFFENER	ST-----
SEAM	SM-----
BUTT	BU-----
MASTER BUTT	MB-----
HEADERS	HR-----
GIRDER	GR-----
<u>MISCELLANEOUS STRUCTURAL NAMES</u>	
PLATE	PL-----
PIECE	PC-----
HOLE	HL-----
BREAST HOOK	BH-----
FASHION PLATE	FP-----
INNER BOTTOM	IB-----
SUB-ASSEMBLY	SA-----
CHOCK	CK-----
BRACKET	BK-----
WEB	WE-----
FLANGE	FG-----
ANCHOR RECESS	AN-----
APPENDAGE	AP-----

Mapping Methodology

Development of HULSTRX included establishing how the structural trace would be accurately mapped onto the various ship surfaces. This mapping process will be described for the shell surface. Before describing the procedure, however, it is first necessary to describe the means for defining the shell geometry.

Surface geometry is defined by a set of grid surface definition lines formed from longitudinal and transverse lines. These lines include a set of control lines which include lines for the centerline, half siding, transom, deck-at-edge, etc. and a group of longitudinal lines. Flat surfaces such as transverse bulkheads, decks, etc., are defined simply by the lines at edges.

For the shell, longitudinal definition lines are primarily iso-girth lines. An iso-girth line is a longitudinal line formed by splining points on sections, where the point on each section is located at a specific fraction of the girth at that section. Additionally, the shell surface geometry can be further defined with other types of longitudinal lines such as waterlines. The longitudinal shell definition lines also include other control lines that specify knuckles or flat plate areas in the hull. For the purposes of this discussion, longitudinal shell definition lines will be referred to as L-lines.

Only the L-lines are used to generate transverse lines (T-lines) which forms the second dimension of the shell definition grid. A T-line is created by intersecting an X-plane with the L-lines. All the points of intersection are splined together to form a line then stored in a working file. The number of transverse cuts of the L-lines made to create this temporary file of T-lines is user-dependent. A T-line is made at every station and in the default case this is automatically supplemented to include T-lines at 1/4, 1/2 and 3/4 station spacing.

Together, the L-lines and the T-lines form a grid of lines over the surface which completely defines its shape. The only information needed to generate this grid is the original L-lines and, for the shell, the stations from the HULL DGL. This information, together with the parametric spline and line-cutting algorithms, provides for a concise means of representing a surface.

Once a temporary surface file is established in memory, each structural trace is mapped onto the surface. The mapping of a trace onto a surface consists of placing the trace in a plane, intersecting this plane with the plane of grid lines, finding the points of intersection and ordering and splining those points to form a line. If a line is entirely in an X-plane one processing step is automatically saved by operating on the original L-line file without the T-lines.

The projection plane of a trace is usually obvious to the user and is selected during input operations. The most accurate projection results when the plane is perpendicular to the surface. For instance, longitudinal stiffeners on the shell located toward the bottom should be placed in the Y-plane, while longitudinal stiffeners on the upper shell should be placed in the Z-plane. Improper selection can result in an inaccurate trace, so the user must be cognizant of all input options available and geometry of the working surface.

The endpoints of a line to be projected must fall on T-lines when projected. If the endpoints do not fall on a T-line, additional T-cuts are generated. Four T-lines forward and aft of the line endpoints are also used, if available, to assure an accurate mapping of a line onto the shell. The splined line resulting from the intersection of the trace and the surface is stored on the surface file only between its actual endpoints.

If an error is encountered during the processing, the program usually does not terminate, but rather an error message is written via the line printer and processing for the next trace started. Some errors, however, are fatal, such as not finding a specified surface file.

Inputs

Three kinds of information are required by HULSTRX as previously shown in Figure 5. They are:

1. Hull form lines
2. Arrangement information, and
3. The structural designer's concept of where the traces should be.

Hull form lines and arrangement information are accessed internally through the DGL. Structural traces require external user inputs.

The basic input to the structural design effort and to HULSTRX is a digital file of the geometrical shape of the hull and the major hull subdivisions as represented by surface intersections. This file was discussed in the DGL section and was shown in Figure 1.

The user input to HULSTRX is a two dimensional description of the desired structural trace and scantling data for the structural member the trace will represent. The structural traces can be input by a variety of methods. The structural trace in endpoint coordinate form can be projected onto the hull from the X, Y or Z planes. In addition, the girth of the structural trace from the ship centerline can be specified at various points and the trace determined from that information. Other input options consist of the ability to create a given number of evenly or equally spaced traces between two specified lines, and the ability to demark a line, by specifying other lines that it is to intersect,

By using the various input methods the designer can achieve a satisfactory definition of the structural traces on various sections of the hull more easily than would be possible using only one method. By using the logical input method for different sections of the shell, satisfactory trace definitions can be achieved more quickly. A good general order for ordering input structural traces is to place the longest structurally continuous piece first. This allows the user to use a line as a trace endpoint instead of relying on (inconsistent) measurements of the endpoint.

The input routines for HULSTRX allow the input to be in a free field form. The inputs are all keyed on a code consisting of a two digit string which always appears in the first two columns. The type of data which will be expected on the following line and also the operation to be performed on the data depends on the contents of that code. Input on the rest of the line is of the free field type. Data and keywords can be separated by commas or blanks or combinations of the two. The input consists of a line name followed by a series of coordinate pairs. These points are used to generate a line in endpoint-tangent form. In addition the end tangents of the line to be generated can be designated during input. For multiple line capability, data includes spacing, number of lines, and boundary lines. Lines of intersection can also be input. A sample data deck is presented as Figure 7. It shows some possible input forms.

outputs

Several output files are created by HULSTRX,

1. Revised multi-surface DGL,
2. Shell expansion file, and
3. Multiple lines file.

The revised multi-surface DGL is the main output. From it, a drawing of any surface can be created. The shell expansion file is a job option and can be used to create a shell expansion drawing without further manipulation. The multiple lines file is solely a users' tool. It is used as a starting point to add detail to individual lines created en masse for input into the next HULSTRX cycle.

DESIGN CONSIDERATIONS

Integration of HULSTRX with the CSD system required design similarity with the Navy programs already developed; therefore, HULSTRX employs many of the concepts implemented in the HULDEF program. The three most important concepts used in parallel with HULDEF are:

1. the file structure and format used for the DGL;
2. the parametric spline used to represent structural traces (3-D lines);
3. the present use of the program in a batch mode.

Many of HULDEF's routines that deal with the lines file and manipulate lines are used in HULSTRX for consistency, and are described in References 3 and 4.

Development of HULSTRX itself has proceeded at two levels: an external user/computer interface, and an internal data manipulation level. The external level tradeoffs include modularity, preprogrammed input decisions and program complexity. The internal tradeoff level concerns the production of the files for the DGL.

External Consideration

Modularity is required in any good programming effort, if only to clearly present the logical flow of the program. For the CSD system, modularity has extra value since modules which are not program-dependent can be used

in other subsystems. This simplifies the integration of the separate programs into a unified whole. In HULSTRX the use of blank common blocks was held to a minimum to achieve independence. Also, sections which might be useful elsewhere, in this program or another, were separated from their parent subroutine.

The amount of input processing desirable was a trade-off constrained on one hand by ease of use for the programmer and on the other by program complexity necessary for decoding the input. Since much of the structural data would have to be input manually or adjusted frequently, a versatile input device was desirable. On the other hand, each additional format that had to be decoded or handled specially added to program size and complexity. The input options made available were discussed previously. Other options may be added as user feedback appears. The input format was developed considering that eventually input will come from SSDP.

Program complexity also entered the design stage in the specification of what the program was to handle. Providing for every eventuality would over-complicate the program and lead to an over-sized system. In general, many trade-offs were made. For example, line traces were limited to having at most 51 points in their definition. Ensuring the program could handle all possibilities likely to arise was a large part of the design in order to avoid user restrictions.

Internal Consideration

Programming problems on the internal level were not so much trade-offs as they were making the program do what it should do. One exception to this was the handling of input errors. Two extremes for dealing with errors are: operating on the false data, and not operating at all. The median solution for HULSTRX was to have the program throw out the line defined on the incorrect data card and continue processing other lines.

The internal problems that had to be solved to get HULSTRX to run properly were mainly in the shell expansion output option. Difficulties with the program occurred when trying to handle non-continuous features such as bulbs, skegs, tunnels, and the transom. Two types of discrepancies arose in handling non-continuous features. One occurred because of the girth-plane representation of the points on the shell. The shell expansion was distorted where appendages added or subtracted girth from the hull.

Extra girth creates a bulge in an ostensibly straight stiffener. Designers simply tack the skegs on after the shell scantlings are developed and do not look at the girth of the shell. This easy solution is not obvious to the computer which relies on a strict geometrical definition of the hull; an appropriate method to handle this is under development.

A second type of distortion occurred where the slope of a line was discontinuous. These were places such as connections of skegs and sonar domes, junctures of flat sections of the hull with curved sections, and sharp edges like the prow and the transom. For this, a further definition of the demarking lines and boundaries was needed to account for the discontinuity.

A major developmental problem was distinguishing between inaccuracies that arose from incorrect input data (a user problem) and those that arose from program errors. An original data base derived from a combination of structural drawings and an existing HULDEF generated hull form was used to aid in program development. Several inconsistencies discovered in the drawings from which the HULSTRX data was derived were the cause of errors in the HULSTRX output. Other errors were produced by limitations in the HULDEF derived hull form description.

HULDEF utilizes a "wire mesh" definition of a hull form to define the hull surface. This is satisfactory for developing the lines plan which is HULDEF's principal purpose. The designer responsible for the lines plan manipulates his HULDEF input until an acceptable lines plan can be produced.

In certain complex areas, such as in way of knuckles or sharp curvature, the amount of input used to define the hull form in HULDEF may be insufficient for satisfactory output from HULSTRX. In these instances, the hull form designer must be informed of the problem and must correct it by supplementing the hull form DGL with additional definition.

Internal information management was another area requiring in-depth analysis. Originally, the hull surface was sectored to save core; one section of the hull was operated on at a time. This saved core because not all of the hull definition grid lines had to be maintained in current memory. Of course some of the saved core space had to be used to hold the sectoring commands. Large time costs were generated by sectoring the hull because of the frequent sector exchanges necessary to process traces sequentially. Since the total core required to support operation on the sectored hull was greater than the look limit applicable to many smaller machines, and since the core required to operate on the entire hull at once was within the limits of the larger computers, sectoring was eliminated. This achieved a time saving of about an order of magnitude. Another time consuming file access problem concerned the transverse cut file. An addition to the end of the transverse cut file augmenting the station cuts with cuts at the quarter points between stations was required to ensure satisfaction of trace end point tangency requirements. This was frequently accessed in a non-sequential manner. Since a computer is a digital number cruncher and not a file reader, significant time savings were gained by calculating any needed inter-station transverse cuts on the fly each time they were used. Another order of magnitude of computing time was saved by not bothering to store the augmenting transverse cut file. The elimination of sectoring and the transverse cut file lowered the core requirements to operate on the entire ship to about the original value. Essentially, no penalty was paid for the reduction of CPU time.

ONGOING DEVELOPMENT

Further development of HULSTRX is currently proceeding in the following areas:

- Trace orientation
- Trace labeling
- Interactive processing
- Multiple line projection

Trace Orientation is being added to the trace definitions so that structural shapes may be added to the drawings in the proper position. The default orientation will be perpendicular to the surface but options will exist to orient the structural shape in an absolute vertical or horizontal position. The orientation of a member is only part of the information needed to draw it. Once the trace orientation is established, the Structural Scantling File will have to be accessed to get the size and shape of the piece.

Trace labeling will make the HULSTRX output more useful. The idea is to print the line name and additional scantling information next to each line on a drawing. This is planned as a development and reference aid.

Interactive processing likewise will make HULSTRX more useful. It will increase the efficiency of a designer who is unfamiliar with the program by prompting him at the appropriate time with the formats and a short description of all inputs necessary to run HULSTRX.

Further development of the multiple line creation portion is underway so that multiple lines may be projected onto the working surface from a different plane, specifically, so that traces may be projected onto the shell from the X, Y or Z planes. This is desirable because, for example, stiffeners on the bottom part of the shell are frequently layed in on a constant Y spacing rather than a constant girth spacing to take advantage of automated production techniques.

FUTURE DEVELOPMENT

Currently, HULSTRX is being run against real life problems to see where it breaks down or doesn't measure up to standards. The conceptual and detail design of HULSTRX is essentially complete. However, in order to get the maximum utility from the program it must be more fully integrated into the CSD system. Any gains in efficiency attributable to the development of this program can be lost many times over if the output requires laborious conversion of data to match the input requirements of other programs.

Three major areas for development of HULSTRX include:

- Structural Synthesis Design Program (SSDP) interface,
- Structural Scantling File (SSF) development,
- Ship Design Weight Estimate (SDWE) interface.

The first major HULSTRX development area is automated input generation. Hull lines are already fed to HULSTRX from HULDEF through the DGL in digitized form. Structural details are developed in SSDP but must be manually massaged before they can be used as input to the present version of HULSTRX. A computer program which would aid the direct data transfer from SSDP to HULSTRX would eliminate the lengthy, and error-prone manual input method. A task is currently in progress addressing this interface program.

The other major HULSTRX development area is to provide for the description of individual structural members associated with each trace. This would be done by creating a separate structural scantlings file (SSF). The structural scantlings file will refer to the structural arrangement traces in the DGL, and, in conjunction with its scantling data, piece orientation, and other special information (Ref. 7, 8) will provide ship designers and builders with a common data base describing the structural members of a ship. This file could then be used as input to programs which would produce plots of ship

structure with complete labeling and listing of all structures, and to programs which would compute structural weight and moments such as SDWE. HULSTRX will be extended to accomplish this objective as mentioned previously.

When using HULSTRX during the design of a ship, the two structural output files, structural traces and structural details, would be distinct and would be developed interactively rather than sequentially. The designer will first establish the locations of certain key structural members, then their scantlings, and finally resolve any compatibility problems between these members and other parts of the hull structure. Separate plotting (UPLLOT) and analysis (SSDP) programs will be used to check the validity of the data placed into the DGL.

The development of the SSDP interface and the portion of HULSTRX which will define the structural scantling file is underway. With the completion of these ongoing tasks, HULSTRX will provide the structural designer with a complete computer aided design package.

REFERENCES

1. Klomparens, S. H., " HULSTRX-A CASDAC Computer Aid for Hull Structural Contract Design," Proceedings of the REAPS Technical Symposium, 1979.
2. "Engineering Development Plan for the CASDAC Hull Subsystem," Naval Ship Engineering Center, Department of the Navy, Washington, D. C.
3. Aughey, M. C., "Unified Hull Definition System," Proceedings of the REAPS Technical Symposium, June 1975, Palm Beach Shores, Florida. Published by the IIT Research Institute, Chicago, Illinois.
4. "Hull Definition Fairing Program Documentation; Volume I, Introduction; Volume II, Users Manua; Volume III Programmers Manual," U.S. Department of Commerce, Maritime Administration, March 1978.
5. Klomparens, S. H., "Structural Data Base Development-Program HLSTRX Composite Design," HYDRONAUTICS, Incorporated Technical Report 7607.73-1, March 1979.
6. Walz, R. W., Lev, F. M., and Nappi, N. S., "Structural Synthesis Design Program," David W. Taylor Naval Ship Research and Development Center Report 77-0032, December 1977.
7. "Properties of Steel Shapes and Plate-Beam Combinations Used in Shipbuilding," Military (Navy) Handbook, September 1979.
8. "Standard Drawing of Structural Details," New Standard Structural Details under development at NAVSEA.

APPENDIX A

ABSTRACT OF RELATED
COMPUTER PROGRAMS

DESCRIPTIVE TITLE : DECKING OUT PROGRAM

ACRONYM DEKOUT
PROGRAM NUMBER 151393
VERSION 1 1 / 1 2 / 7 6
AVAILABLE NAVSEA 03R2. WASHINGTON, D. C. 20362
DEVELOPED BY NAVSEA 3211 (UNDER DEVELOPMENT)
POINT OF CONTACT C. CARLSON SEA 3211, (202) 692-1400
DOCUMENTATION
SECURITY CLASSIFICATION UNCLASSIFIED 0
PROGRAMMING LANGUAGE(S) FORTRAN IV
COMPUTER VERSION(S) CDC
DECK SIZE(S)
OBJECT SIZE(S)
SPECIAL HARDWARE GRAPHICS DISPLAY
SPECIAL SOFTWARE DAM (#530101)
RUN TIME . TEST DECK
DISTRIBUTION MEDIA MAGNETIC TAPE
PROGRAM SUMMARY DATE 11 NOV 76

PROGRAM ABSTRACT :

THE DECKING OUT PROGRAM IS USED TO DEFINE THE LOCATION OF SUBDIVISION BULKHEADS, AND THE LOCATIONS AND GEOMETRY OF DECKS, PLATFORMS, LEVELS, AND THE SUPER-STRUCTURE ENVELOPE BY USE OF INTERACTIVE GRAPHICS.

DESCRIPTIVE TITLE : HULL FORM GENERATOR

ACRCNYM HULGEN
PROGRAM NUMBER I51343
VERSION

AVAILABLE NAVSEA 03R2, WASHINGTON, D. C. 20362

DEVELOPED BYNAVSEA 312

POINT OF CONTACT F. BJORKFUND SEA 31222. (202) 692-8160

DOCUMENTATION COMPLETE
SECURITY CLASSIFICATION UNCLASSIFIED
PROGRAMING LANGUAGE(S) FORTRAN IV
COMPUTER VERSION(S) CDC 6700/TEKTRONIX TERMINAL VERSION
DECK SIZE(S) 11250
OBJECT SIZE (S) CM61000
SPECIAL HARDWARE TEKTRONIX 4015 STORAGE TUBE TERMINAL
SPECIAL SOFTWARE INTERCOM AND TEKTRONIX PLOT IO GRAPHICS
RUN TIME TEST DECK 2
DISTRIBUTION MEDIA MAGNETIC TAPE
PROGRAM SUMMARY DATE 04 JAN 78

PROGRAM ABSTRACT :

GIVEN THE VERY MINIMUM INPUT OF LENGTH, BEAM, DRAFT, PRISMATIC AND MIDSHIP SECTION, COEFFICIENTS, LCR, LCF, AND A DECK AT EDGE DEFINITION: HULGEN COMPUTES ALL OF THE INITIAL PARAMETERS AND CONTROL CURVES REQUIRED TO PRODUCE A BODY PLAN. THIS BODY PLAN IS NOT THE ONE-DESIRED, BUT PROVIDES A STARTING POINT FOR ANY VARIATIONS THE USER WANTS TO MAKE.

THE SHIP HULL FORM GENERATOR (HULGEN) USES A PIECEWISE POLYNOMIAL DEVELOPMENT AND REPRESENTATION OF AN EARLY STAGE DESIGN SHIP'S BODY PLAN. IT WAS ORIGINALLY WRITTEN FOR REFRESH GRAPHICS SCOWS WITH LIGHT PENS. THOSE EARLIER VERSIONS OF THE PROGRAM ALTHOUGH DONE FOR LIGHT PEN PICKS, OPERATED IN A WAY THAT MADE CONVERSION TO STORAGE TUBE GRAPHICS VERY PRACTICAL. THE DISPLAYS WERE CHANGED VERY LITTLE AND THE INTERACTIVE LIGHT PEN PICKS WERE CONVERTED TO KEYBOARD ENTRY MENUS. THE USER NOW TYPES A MENU OPTION AND/OR DATA TO PROCEED.

HULGEN WAS DEVELOPED SPECIFICALLY FOR THE EARLY STAGE DESIGN PROBLEM OF DEVELOPING MANY OPTIONAL HULLS RAPIDLY. AT THIS POINT IN THE DESIGN IT IS IMPORTANT TO BE ABLE TO DETERMINE WHETHER THE DESIRED HULL FORM CAN BE DEVELOPED

DESCRIPTIVE TITLE : SHIP HULL CHARACTERISTICS PROGRAM

ACRONYM SHCP
PROGRAM NUMBER 231072
VERSION JAN 76
AVAILABLE NAVSEA 03R2, WASHINGTON, D.C. 20362
DEVELOPED BY NAVAL SEA SYSTEMS COMMAND
POINT OF CONTACT M. AUGHEY SEA. 3212, (202) 692-9070
DOCUMENTATION INCOMPLETE (USER'S MANUAL AVAILABLE)
SECURITY CLASSIFICATION UNCLASSIFIED
PROGRAMMING LANGUAGE(S) FORTRAN
COMPUTER VERSION(S) CDC 6700
DECK SIZE(S) 10000
OBJECT SIZE(S) 47500
SPECIAL HARDWARE CALCOMP PLOTTER (OPTIONAL)
SPECIAL SOFTWARE CALCOMP
RUN TIME . TEST DECK 8.9SEC
DISTRIBUTION MEDIA TAPE 9 TRACK, 800BPI, UNBLOCKED, CARD IMAGE
PROGRAM SUMMARY DATE 24 APR 76

PROGRAM ABSTRACT :

SHOP CONSISTS OF A SET OF SUBPROGRAMS WHICH PERFORM THE FOLLOWING NAVAL ARCHITECTURAL CALCULATIONS: HYDROSTATICS, TRIM LINES, LONGITUDINAL STRENGTH, FLOODABLE LENGTH, LIMITING DRAFTS, INTACT STAR., DAMAGED STAR. CROSS CURVES, DAMAGED STATICAL STAR., INTACT STATICAL STAR. ON WAVES.

THESE CALCULATIONS ARE PERFORMED ON A COMMON DATA BASE, THE SHIP DATA TABLE, WHICH IS SET UP FROM THE USER SUPPLIED DESCRIPTION OF THE HULL FORM. EACH SET OF PROPERTIES CALCULATED REQUIRES ITS OWN SET OF INPUT DATA.

ASSUMPTIONS:

- 1 STATION SHAPE ADEQUATELY DESCRIBED BY 2ND ORDER CURVE SEC.
- 2 SIMPSON'S 1-4-1 RULE FOR INTEGRATIONS.
- 3 INTERPOLATIONS OF AREAS AND PROPERTIES DONE BY TAYLORS SECOND ORDER COEFFICIENTS.
- 4 ITERATION FOR BALANCE DONE BY NEWTON-RAPHSON.

THE PROGRAMS WILL CALCULATE DAMAGED COMPARTMENT WATER-PLANE INERTIAS, GENERATE CIRC. OFFSETS. ALLOW FOR INPUT OF APPENDAGES. MANY FLCTS CAN BE GENERATED DEPENDING ON WHICH OPTIONS ARE SELECTED.

DESCRIPTIVE TITLE : SHIP DESIGN WEIGHT ESTIMATE

ACRONYM SO WE
PROGRAM NUMBER 230021
VERSION 06/29/78
AVAILABLE NAVSEA 03R2, WASHINGTON, D. C. 20362
DEVELOPED BY NAVSEA 3212
POINT OF CONTACT P. KERN SEA 3212. (202) 692-9070
DOCUMENTATION COMPLETE, USERS AND PROG. MAINT.
SECURITY CLASSIFICATION UNCLASSIFIED
PROGRAMING LANGUAGE(S) FORTRAN IV AND COMPASS
COMPUTER VERSION(S) CDC 6700
DECK SIZE(S) 6368
OBJECT SIZE(S) 555008
SPECIAL HARDWARE NONE
SPECIAL SOFTWARE NONE
RUN TIME - TEST DECK 1 MIN
DISTRIBUTION MEDIA MAGNETIC TAPE (7 OR 9 TRACK)
PROGRAM SUMMARY DATE 29 JUN 78

PROGRAM ABSTRACT :

THE SHIP DESIGN WEIGHT ESTIMATE COMPUTES PROGRAM SUMMARIZES WEIGHTS AND MOMENTS FROM DETAIL DATA WHICH IS SUPPLIED BY THE USER. THE DETAIL DATA INCLUDES WEIGHT, CENTER OF GRAVITY, DESCRIPTION, 3 CHARACTER CLASSIFICATION GROUP, 2 DIGIT SUBGROUP AND ITEM NUMBER. SUMMARIES OF THE INPUT DATA ARE PROVIDED WHENEVER THE FIRST CHARACTER OR ALL 3 CHARACTERS OF THE GROUP CHANGE OR THE SUBGROUP CHANGES. THE CLASSIFICATION SYSTEMS UPON WHICH THE PROGRAM IS BASED ARE THE NAVY DEPARTMENT SWBS AND BSCI.

ADDITIONAL FEATURES ARE - UP TO 12 LOADING CONDITIONS, MARGINS, HYDROSTATICS COMPUTATIONS BASED ON THE DISPLACEMENT AND LCG OF EACH LOADING CONDITION, LONGITUDINAL WEIGHT DISTRIBUTION, ENGLISH-METRIC UNITS CONVERSIONS AND OTHER MINOR CAPABILITIES.

THIS PROGRAM CAN BE USED IN CONJUNCTION WITH THE SDWE DATA UPDATE PROGRAM (CASDAC MBKQ, 230143) WHICH MANAGES THE DETAIL DATA STORAGE FILE.

DESCRIPTIVE TITLE 1 SHIP SYNTHESIS DESIGN PROGRAM

ACRONYM SSDP
PROGRAM NUMBER 233021
 VERSION 05-15-70
AVAILABLE NAVSEA 03R2. WASHINGTON. D. C. 20362

DEVELOPED BY NAVAL SHIP RESEARCH AND DEVELOPMENT CENTER

POINT OF CONTACT NAPI/LEV

DOCUMENTATION COMPLETE - FORMAL
SECURITY CLASSIFICATION UNCLASSIFIED
PROGRAMMING LANGUAGE(S) FORTRAN IV
COMPUTER VERSION(S) CDC 6700
DECK SIZE(S) 11200
OBJECT SIZE(S) 250000 OCTAL
SPECIAL HARDWARE SC4020
SPECIAL SOFTWARE SC4020
RUN TIME . TEST DECK
DISTRIBUTION MEDIA MAGNETIC TAPE
PROGRAM SUMMARY DATE 24 APR 76

PROGRAM ABSTRACT

A COMPUTER PROGRAM DESCRIBED WHICH WILL DESIGN THE LONGITUNINAL SCANTLINGS OF A STEEL MIDSHIP SECTION. ANY PRACTICAL COMBINATIONS OF DECKS. PLATFORMS. AND LONGITUDINAL BULKHEADS FOR THE MIDSHIP SECTION CONFIGURATION MAY BE USED. OPTIONS TO INCLUDE AN INNER BOTTOM STRUCTURE. AND TO PERFORM A NUCLEAR AIR BLAST ANALYSIS OF SHELL AND UPPER STRENGTH DECK STRUCTURE ARE PROVIDED.

THE PROGRAM CONTAINS THE DECISIONS NECESSARY TO DETERMINE AN INITIAL SET OF MINIMUM WEIGHT SCANTLINGS FOR THE SHELL, DECK, BULKHEAD, AND INNER BOTTOM SEGMENTS, TEST THEM TO DETERMINE COMPLIANCE WITH THE DESIGN CRITERIA AS DEFINED BY THE NAVAL SHIP ENGINEERING CENTER. AND THEN INCREASE THE SCANTLINGS IF THE CRITERIA IS NOT SATISFIED. MODIFICATION OF SCANTLINGS CONTINUES UNTIL THE SCANTLINGS DEVELOPED DO NOT CHANGE THE PRIMARY STRESS ASSIGNMENT. IF THE MIDSHIP SECTION HAS A PRIMARY STRESS DEFICIENCY AT THE DECK AND/OR KEEL FIBERS THE PROGRAM WILL AUTOMATICALLY ADJUST THE MATERIAL AT THESE FIBERS AND ITERATE THE DESIGN PROCESS UNTIL SCANTLINGS ARE FOUND THAT ARE OF MINIMUM WEIGHT AND STRUCTURALLY ADEQUATE.

DESCRIPTIVE TITLE : UTILITY DRAFTING ROUTINE

ACRONYM UP LOT
PROGRAM NUMBER 5201192
VERSION 01-74
AVAILABLE NAVSEA C3R2, WASHINGTON, D. C. 20362
DEVELOPED BY AUGHEY SEA 3212
POINT OF CONTACT M AUGHEY SEA 3212, (202) 692-9070
DOCUMENTATION COMPLETE
SECURITY CLASSIFICATION ... UNCLASSIFIED
PROGRAMMING LANGUAGE(S) ... FORTRAN
COMPUTER VERSION(S) CDC 6700
DECK SIZE(S) 2204
OBJECT SIZE(S) 30000
SPECIAL HARDWARE CALCOMP/GERBER PLOTTER
SPECIAL SOFTWARE CALCOMP/GERBER PLOTTER
RUN TIME . TEST DECK 2.6
DISTRIBUTION MEDIA MAGNETIC TAPE
PROGRAM SUMMARY CAT 04-24-76

PROGRAM ABSTRACT :

UTILITY PLOT (UP LOT) IS A SIMPLE PROGRAM WHICH ALLOWS USERS TO DESCRIBE DRAFTING TYPE PLOTS. THE INPUT DESCRIPTIONS OF THE DESIRED DRAWING ARE ON CARDS. THE OUTPUT IS ON CALCOMP OR GERBER-TYPE PLOTTERS, WHICHEVER IS AVAILABLE. A CONSIDERABLE EFFORT HAS BEEN MADE TO ACHIEVE MACHINE INDEPENDENCE. THE THREE VERSIONS (IBM 1130, CDC 6700/CALCOMP, CDC 6700/GERBER) WILL ALL PRODUCE SIMILAR PLOTS FROM THE SAME DATA, AND 'EXCEPT FOR THE PLOTTER INTERFACE ROUTINES. THE FORTRAN PROGRAMS ARE A VERY LIMITED SUBSET OF BASIC FORTRAN. ONCE DESCRIBED ON THE INPUT CARDS, EACH "TEMPLATE." BECOMES, MORE OR LESS PAYMENT AND CAN BE USED AS A BASE TO BUILD UPON OR OVERLAY OTHER DRAWING INFORMATION. THIS PERMITS COMPLEX DRAWINGS TO BE BUILT UP OVER A PERIOD OF TIME AND COMPONENTS OF THOSE DRAWINGS TO BE USED REPEATEDLY.

APPENDIX B
VIEWGRAPHS FROM PRESENTATION

U.S. NAVY
CAD/CAM PROGRAM
HULL STRUCTURE

HULSTRX

HULSTRX USN CSD SUBSYSTEM

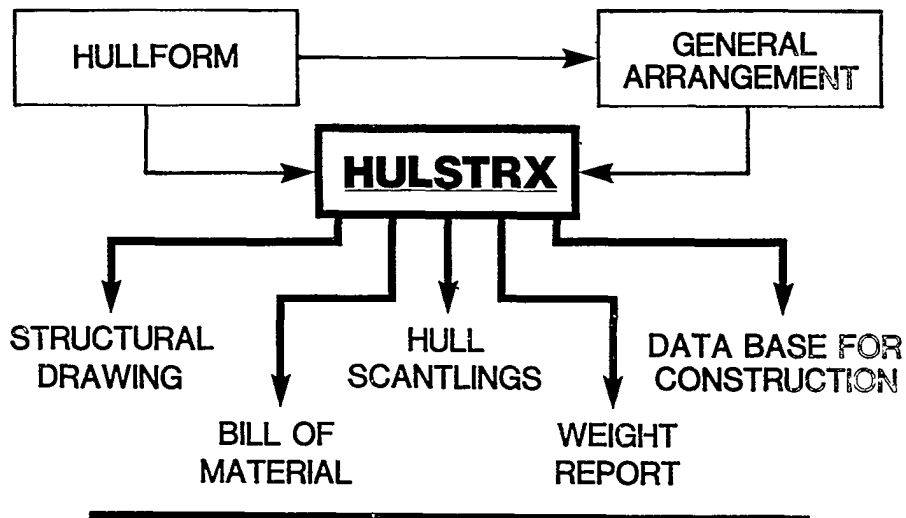

HULSTRX INTRODUCTION

- INITIAL DEVELOPMENT UNDER CASDAC
 - NAVY'S COMPUTER AIDED SHIP DESIGN AND CONSTRUCTION PROJECT
 - 1979
 - ONGOING DEVELOPMENT UNDER CSD
 - NAVY'S COMPUTER SUPPORTED DESIGN PROJECT
-

HULSTRX INTRODUCTION

OBJECTIVE OF PRESENTATION

- REVIEW DESIRED CAPABILITIES
 - DEMONSTRATE PRESENT CAPABILITIES
 - DISCUSS ONGOING AND FUTURE DEVELOPMENT
-

HULSTRX THE NAVY CSD SYSTEM

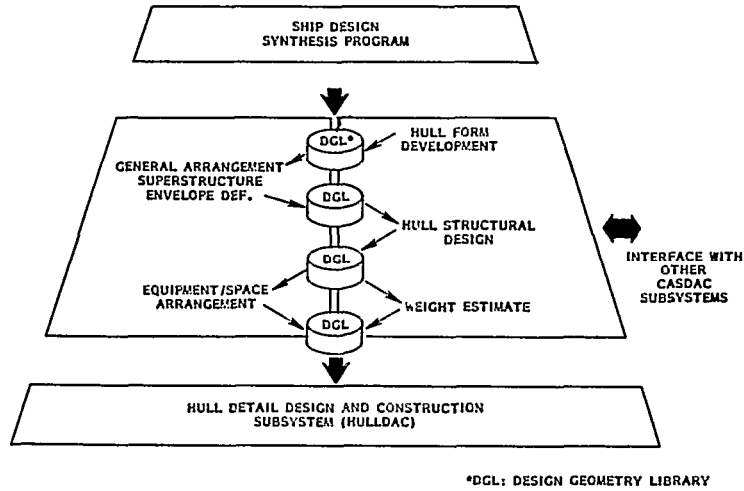

HULSTRX CSD'S STRUCTURAL PORTION

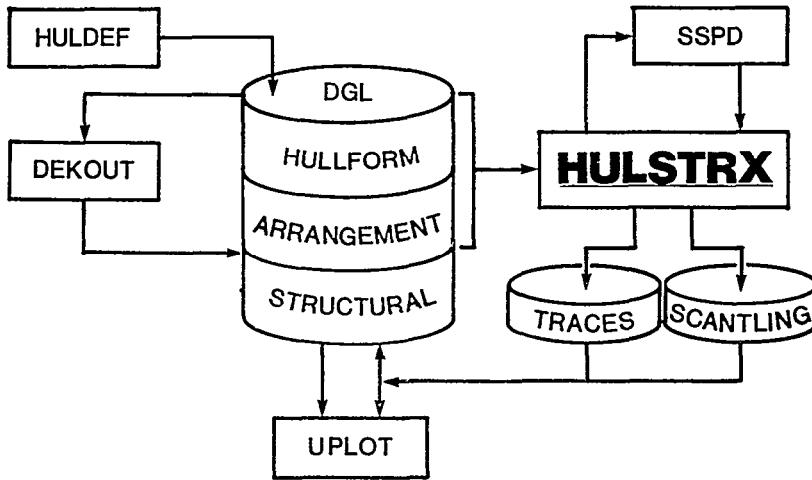

HULSTRX DESIGN CONSIDERATIONS

- CONCEPTS USED IN PARALLEL WITH HULDEF
 - FILE STRUCTURE AND FORMAT OF DGL
 - PARAMETRIC SPLINE FOR REPRESENTING 3-D LINES
 - OPERATION IN BATCH MODE

HULSTRX THE NAVY CSD SYSTEM

n STRUCTURAL DGL

- INPUT FOR STRUCTURAL DESIGN PROGRAMS
- BASIS FOR COMPUTER GENERATED DRAWINGS
- AS A DESIGN DELIVERABLE ITSELF

HULSTRX OBJECTIVES

n CURRENT OBJECTIVES

- SHELL EXPANSION DRAWINGS
- DECK DRAWINGS
- BULKHEAD DRAWINGS } [INCLUDING
SUPERSTRUCTURE
- SECTION DRAWINGS
- STRUCTURAL DATA BASE

HULSTRX STATUS REVIEW

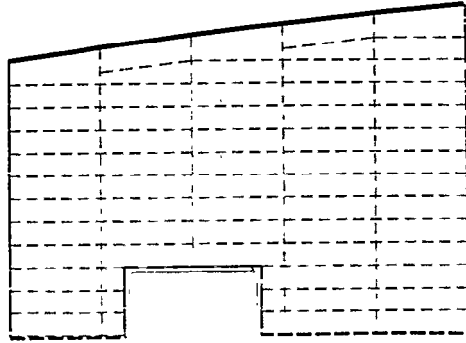

HULSTRX STATUS REVIEW

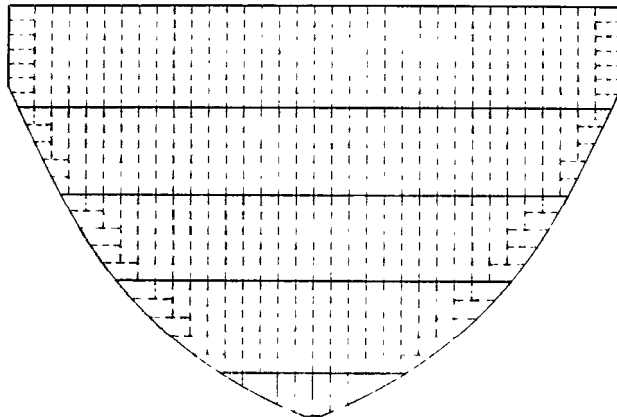

HULSTRX STATUS REVIEW

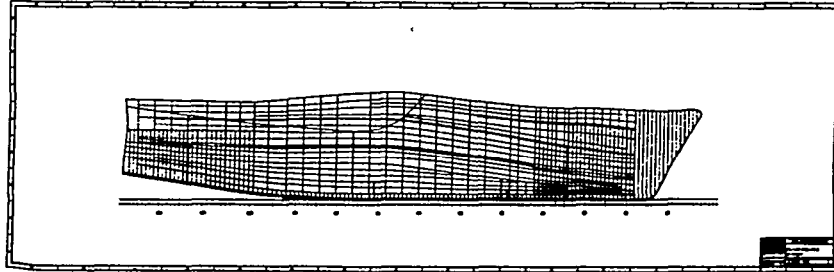

HULSTRX OUTPUT; SHELL EXPANSION



```

01 SURFACE SHCOOB          DATE 8/11/01
02 EXPF
1312 M 13 SP .5 19 CL0000 19 SW0000 1 190025 1 190129
09 ST2000 LB3001 ST2002 192001 LB2004 LB2005 ST3004
09 LB5007 ST5008 LB5009 ST5010 LB5011 ST5012
1314 M 7 19 SW0008 19 SW0003 1 190025 1 190129 ST0000
1314 M 4 19 SW0001 19 SW0002 1 190025 1 190129 ST1000
1314 M 6 SP .5 19 SW0000 19 SW0002 1 190025 1 190129 ST2000
1341 M 32 19 190025 19 190129 1 CL0000 1 SW0000 ST3004
99
  
```

HULSTRX OUTPUT; SHELL EXPANSION DETAIL

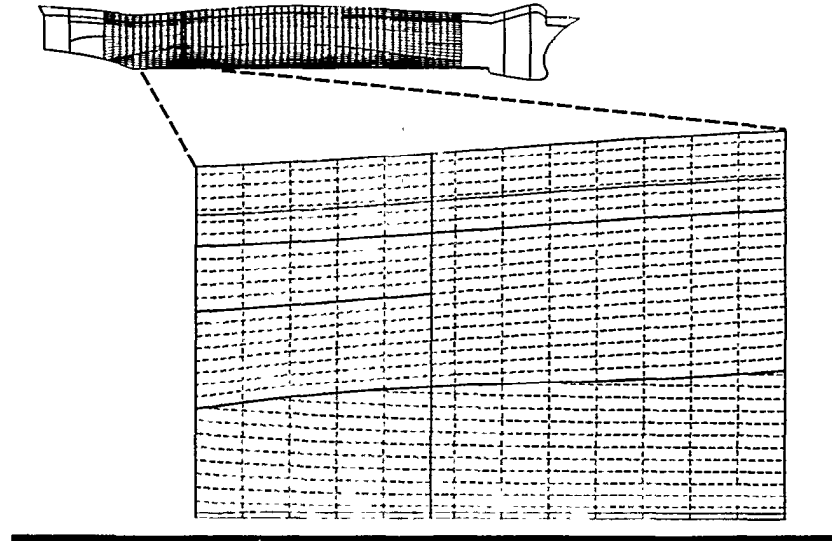

HULSTRX GROUNDRULES FOR DEVELOPMENT

- HULDEF: POINT OF DEPARTURE
 - DGL FILE STRUCTURE AND FORMAT
 - PARAMETRIC SPLINE FOR 3-D LINE REPRESENTATION
 - END POINT TANGENT DEFINITION FOR LINE SEGMENTS
- COMPATIBILITY WITH OTHER EXISTING CSD PROGRAMS (SSDP, SHCP, ETC.)
- (INITIALLY:) BATCH MODE OPERATION

HULSTRX OPERATIONAL ASPECTS

■ DGL STRUCTURE

```

SHIP, DATE
SURFACE NAME
TRACES IN END
PT/TANGENT FORM
BLANK RECORD
SURFACE NAME
TRACES
BLANK RECORD
[ ]
[ ]
[ ]
LAST SURFACE
BLANK RECORD
BLANK RECORD
EOF
    
```

HULSTRX OPERATIONAL ASPECTS

■ LINE TYPES & MNEMONIC IDENTIFIERS

	<u>STRUCTURAL TRACES</u>	<u>IDENTIFIER</u>
	STIFFENER	ST----
	SEAM	SM----
	BUTT	BU----
	MASTER BUTT	MB----
	HEADERS	HR----
<u>SHELL GEOMETRY TRACES</u>	<u>SURFACE NAMES AND TRACES</u>	
FORM LINE	F-----	SHELL (PORT)
GIRTH LINE	G-----	SHELL (STARBOARD)
CONTROL LINE	C-----	GIRDER
DISPLAY LINE	D-----	JOINER BULKHEAD
STATION	STA---	
FRAME	FR----	
WATERLINE	WL----	<u>MISCELLANEOUS STRUCTURAL NAMES</u>
BUTTOCK	BT----	PLATE
DIAGONALS	DI----	PIECE
		HOLE
		BREAST HOOK
		FASHION PLATE
		INNER BOTTOM
<u>ARRANGEMENT TRACES</u>		SUB-ASSEMBLY
TRANSVERSE BULKHEAD	TB----	CHOCK
WEB FRAMES	WF----	BRACKET
DECK	DK----	JEB
PLATFORMS	PF----	FLANGE
FLATS	FL----	ANCHOR RECESS
LONGITUDINAL BULKHEAD	LB----	APPENDAGE
SKEW BULKHEAD	SB----	

HULSTRX INPUT OPTION

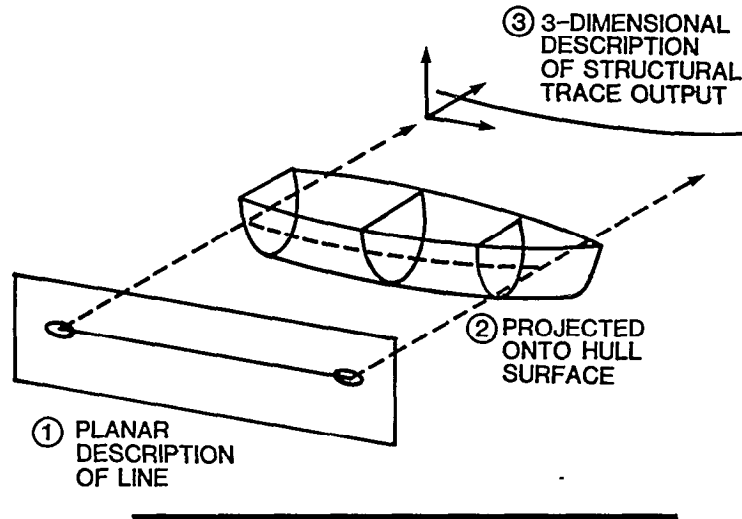

HULSTRX INPUT OPTION

■ AVAILABLE INPUT OPINIONS

- PROJECT FROM X-PLANE
- PROJECT FROM Y-PLANE ◀
- PROJECT FROM Z-PLANE
- PROJECT FROM GIRTH-PLANE

- LAY IN MULTIPLE EQUALLY SPACED LINES FROM ANY PLANE
- LAY IN MULTIPLE EVENLY SPACED LINES FROM ANY PLANE

- BEGIN OR END LINE ON PREVIOUSLY DEFINED TRACE
- DEFINE START OR END TANGENTS

HULSTRX INPUT FILE



INPUT CARDS

```

01 SURFACE SHOOOS          DATE 0/11/81
02 EPPF
1512 M 11 SP -3 IB CL0000 IB BK0008 I TB0025 I TB0129
49 ST0000 LB5001 ST5002 LB7003 ST5004 LB2005 ST5006
49 LB5007 ST5008 LB5009 ST5010 LB5011 ST5012
1514 M 7 IB BK0008 IB DK0003 I TB0025 I TB0129 ST0000
1514 M 4 IB BK0003 IB BK0002 I TB0025 I TB0129 ST0000
1514 M 4 SP -3 IB CLAW00 IB BK0002 I TB0025 I TB0129 ST0000
1541 M 52 IB TB0025 IB TB0129 I CL0000 I CLAW00 ST0000
99

```

10 LINES

HULSTRX INPUT ILLUSTRATION



```

01 SURFACE SHOOOS          DATE 0/11/81
02 EPPF
1512 M 11 SP -3 IB CL0000 IB BK0008 I TB0025 I TB0129
49 ST0000 LB5001 ST5002 LB7003 ST5004 LB2005 ST5006
49 LB5007 ST5008 LB5009 ST5010 LB5011 ST5012
1514 M 7 IB BK0008 IB DK0003 I TB0025 I TB0129 ST0000
1514 M 4 IB BK0003 IB BK0002 I TB0025 I TB0129 ST0000
1514 M 4 SP -3 IB CLAW00 IB BK0002 I TB0025 I TB0129 ST0000
1541 M 52 IB TB0025 IB TB0129 I CL0000 I CLAW00 ST0000
99

```

-----1514 N 7 IB DK0008 IB DK0003 I TB0025 I TB0129 ST0000-----

HULSTRX ONGOING DEVELOPMENT

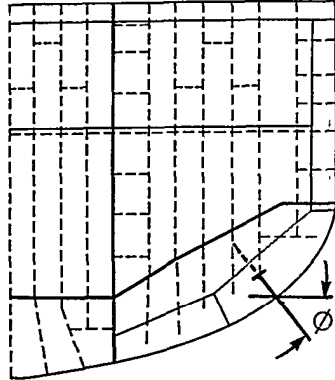

- TRACE ORIENTATION
- TRACE LABELING
- STIFFENER DEFINITION (FROM SSF)

HULSTRX ONGOING DEVELOPMENT

GIRTH DISTORTIONS

CURRENT

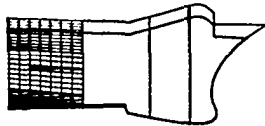

UNDER DEVELOPMENT

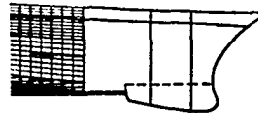

HULSTRX_FUTURE DEVELOPMENT

n AREAS OF FUTURE HULSTRX DEVELOPMENT

- STRUCTURAL SYNTHESIS DESIGN PROGRAM (SSDP) INTERFACE
- STRUCTURAL SCANTLING FILE (SSF) DEVELOPMENT
- SHIP DESIGN WEIGHTS ESTIMATE (SDWE) INTERFACE
- BILL OF MATERIAL

HULSTRX SUMMARY

n ONE, DATA BASE FOR HULL DESIGN:

INHERENT CONSISTENCY OF SHIP

- DESIGN DISCIPLINES (HULL FORM ARRANGEMENTS, STRUCTURES, ETC.)
- DESIGN REPRESENTATIONS (DECK, BULKHEADS, SHELL, ETC.)

n COMPUTER- AIDED DRAFTING:

ACCURACY AND LEGIBILITY

- ▶EASY SCALE ADJUSTMENT/MULTIPLE USE
- ▶INCREASED EFFICIENCY AND VERSATILITY

n INTEGRATED WITH EXISTING PROGRAMS UNDER CSD

Additional copies of this report can be obtained from the
National Shipbuilding Research and Documentation Center:

<http://www.nsnet.com/docctr/>

Documentation Center
The University of Michigan
Transportation Research Institute
Marine Systems Division
2901 Baxter Road
Ann Arbor, MI 48109-2150

Phone: 734-763-2465
Fax: 734-763-4862
E-mail: Doc.Center@umich.edu