



# *Highly Efficient Nonwoven CW Decontamination Wipe*

Utkarsh Sata, Senthil Chinnasami, Lohit Shastri and  
S.S. Ramkumar

*The Institute of Environmental and Human Health  
Texas Tech University  
Box 41163, Lubbock TX 79409-1163*

# Report Documentation Page

Form Approved  
OMB No. 0704-0188

Public reporting burden for the collection of information is estimated to average 1 hour per response, including the time for reviewing instructions, searching existing data sources, gathering and maintaining the data needed, and completing and reviewing the collection of information. Send comments regarding this burden estimate or any other aspect of this collection of information, including suggestions for reducing this burden, to Washington Headquarters Services, Directorate for Information Operations and Reports, 1215 Jefferson Davis Highway, Suite 1204, Arlington VA 22202-4302. Respondents should be aware that notwithstanding any other provision of law, no person shall be subject to a penalty for failing to comply with a collection of information if it does not display a currently valid OMB control number.

1. REPORT DATE <b>17 NOV 2004</b>		2. REPORT TYPE <b>N/A</b>		3. DATES COVERED <b>-</b>	
4. TITLE AND SUBTITLE <b>Highly Efficient Nonwoven CW Decontamination Wipe</b>				5a. CONTRACT NUMBER	
				5b. GRANT NUMBER	
				5c. PROGRAM ELEMENT NUMBER	
6. AUTHOR(S)				5d. PROJECT NUMBER	
				5e. TASK NUMBER	
				5f. WORK UNIT NUMBER	
7. PERFORMING ORGANIZATION NAME(S) AND ADDRESS(ES) <b>The Institute of Environmental and Human Health Texas Tech University Box 41163, Lubbock TX 79409-1163</b>				8. PERFORMING ORGANIZATION REPORT NUMBER	
9. SPONSORING/MONITORING AGENCY NAME(S) AND ADDRESS(ES)				10. SPONSOR/MONITOR'S ACRONYM(S)	
				11. SPONSOR/MONITOR'S REPORT NUMBER(S)	
12. DISTRIBUTION/AVAILABILITY STATEMENT <b>Approved for public release, distribution unlimited</b>					
13. SUPPLEMENTARY NOTES <b>See also ADM001849, 2004 Scientific Conference on Chemical and Biological Defense Research. Held in Hunt Valley, Maryland on 15-17 November 2004 . , The original document contains color images.</b>					
14. ABSTRACT					
15. SUBJECT TERMS					
16. SECURITY CLASSIFICATION OF:			17. LIMITATION OF ABSTRACT	18. NUMBER OF PAGES	19a. NAME OF RESPONSIBLE PERSON
a. REPORT <b>unclassified</b>	b. ABSTRACT <b>unclassified</b>	c. THIS PAGE <b>unclassified</b>			



## Why is it important to develop lightweight and breathable chemical protective substrates?



**Mustard gas victim**

[[www.firstworldwar.com](http://www.firstworldwar.com)]

### Types of Agents:

- Nerve Agents
- Blister/Vesicant Agents
- Blood Agents
- Pulmonary Agents

All that body Suffocation ??



[[www.breathingequipmenthire.fsnet.co.uk](http://www.breathingequipmenthire.fsnet.co.uk)]



[[www.israel-bodyguards.com](http://www.israel-bodyguards.com)]



[[www.sptimes.com](http://www.sptimes.com)]

*Seeking protective clothing:  
Abo Saad checks out a chemical  
suit for sale in the house wares  
department of a Kuwaiti market.*



## *Novel Approach: Nonwoven Technology*



*Research program utilizes needlepunching technology to develop chemical warfare protective substrates*

*Important characteristics for chemical protective substrates include:*

- *Toxic chemical adsorption*
- *"Next-to-Skin" friendliness*
- *Breathability*

*Characteristics conflict with each other -  
Nonwoven technology could be the  
solution*

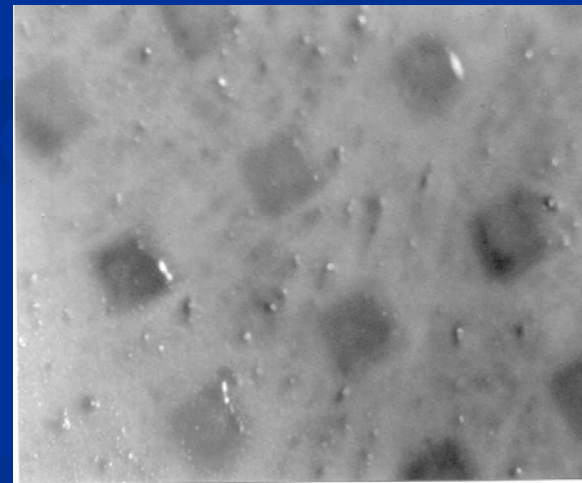

Zero breathable chemical warfare protective substrate



## *Needlepunching Nonwoven Technology*



*Needlepunching technology has been used to develop a three-layered chemical protective substrates that could find applications such as:*

- 1. Flexible chemical warfare decontamination wipe*
- 2. Protective inner lines for chemical protective suit*

*A US patent application entitled, "Method of producing Chemical Composite Substrate," is pending*

*H1 contoured needle zone needlepunching technology has been used to develop nonwoven chemical protective substrates*



## *H1 Technology Needlepunching*

- *H1 technology is the latest development in needlepunching from Fehrer-AG, Austria*
- *The needle zone is contoured unlike flatbed conventional needlepunching*
- *Texas Tech University is the first and only academic facility in the US to house the modern needlepunching line*



## *H1 Technology: Characteristics*

- *Oblique angle needle penetration due to contoured needle zone*
- *Longer needle path results in better fiber orientation and fiber entanglement*
- *Higher needling speeds – maximum possible is 1300 strokes/min*



## *H1 - Needle Loom*





## *Novel Nonwoven Decontamination Wipe*



*The three-layered nonwoven decontamination wipe consists of :*

- 1. Pre-filter (Top) Layer, L1*
- 2. Middle Adsorbent Layer, L2*
- 3. Next-to-Skin (Bottom) Layer, L3*

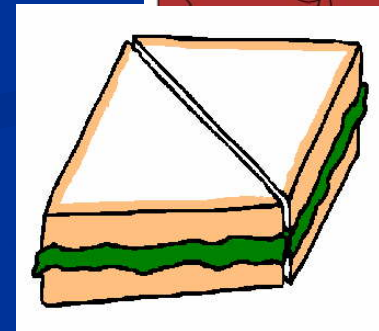

*Three layered structure was needlepunched at high speed to form a composite*



## Decontamination Wipe

*L1 Pre-filter layer*

*L2 Middle adsorbent layer*

*L3 Next-to-skin layer*

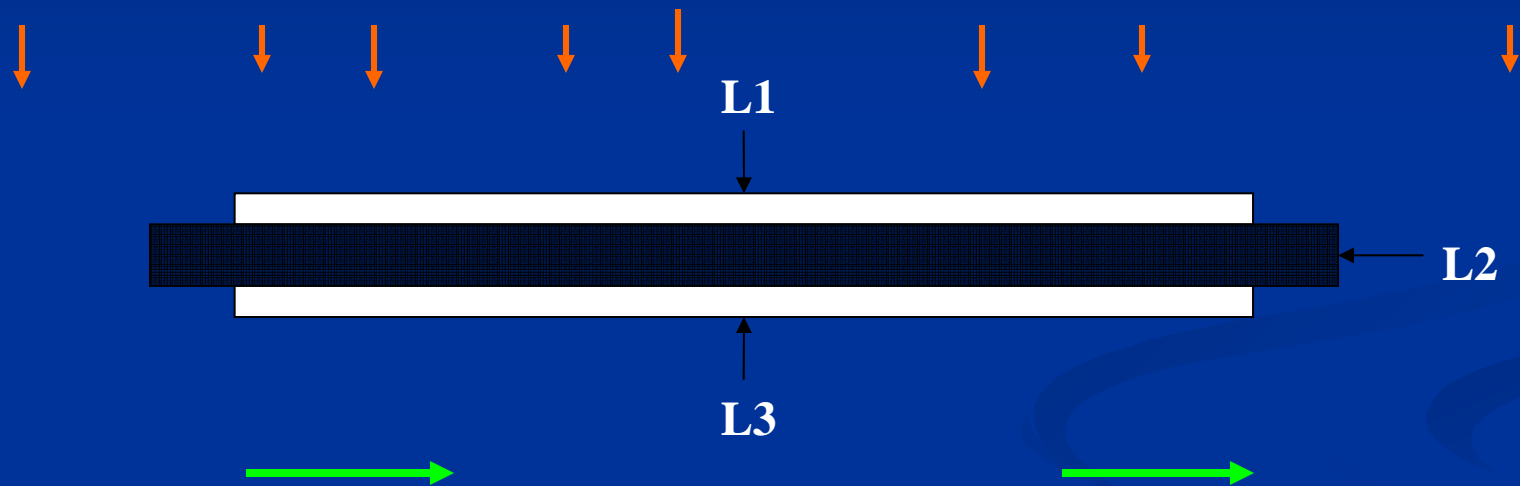

*The three layered protective composite fabric which can effectively serve as a decontamination wipe was manufactured using H1 technology needle loom*



## Nonwoven Line – Texas Tech University



Hopper Feeder

*Opening – fine beating and tuft reduction*

Double Cylinder Card

*Web forming – removal of tufts; parallel orientation*

Cross Lapper

*Web formation - high loft, layered webs*

H1 Needle Loom

*Web consolidation – Interlocking of fibers*



# H1 Needlepunching Line





## *H1 Contoured Needle Zone*

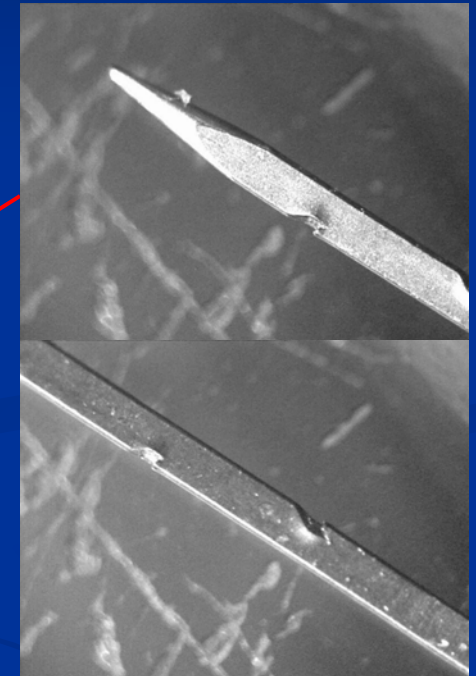
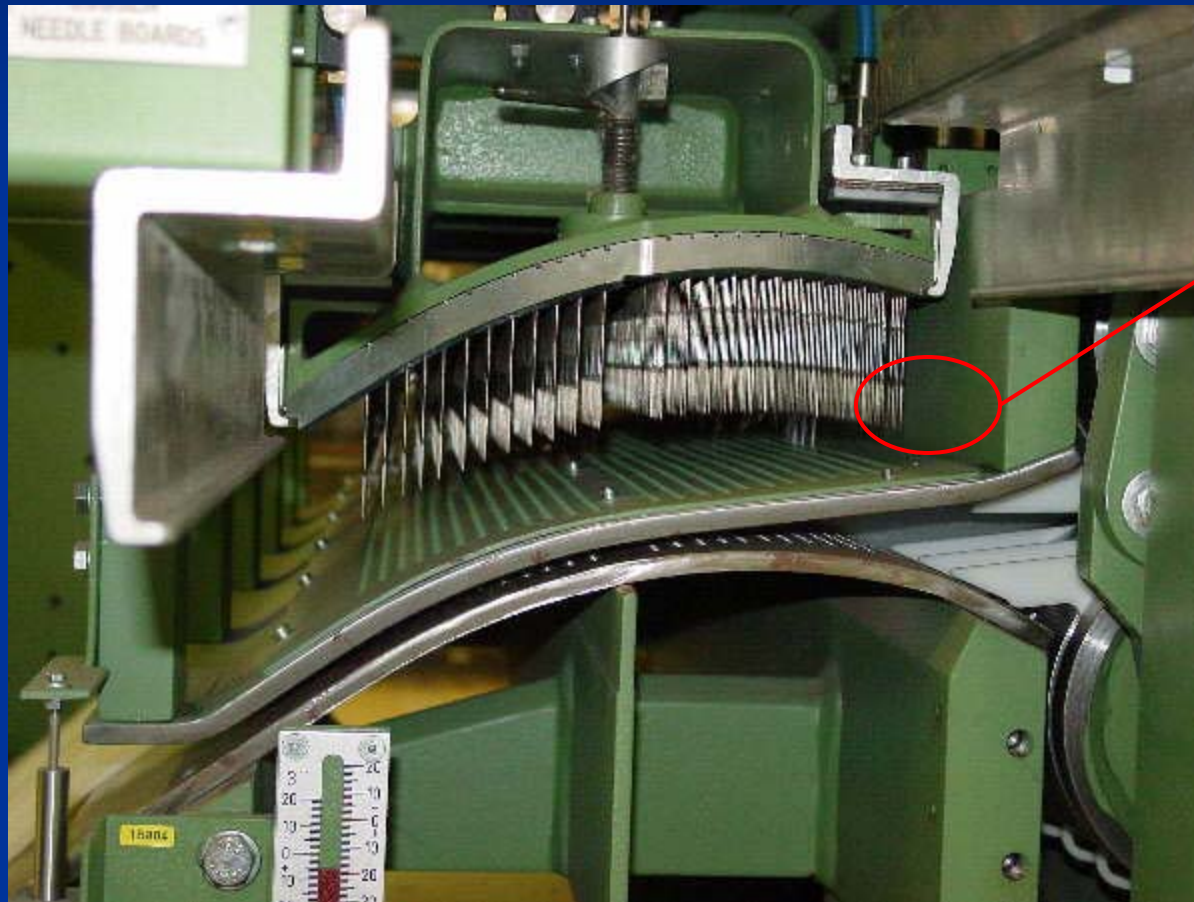



# Decontamination Wipe Development Process



No Picture



## *Next-to-Skin Friendly Decontamination Wipe*

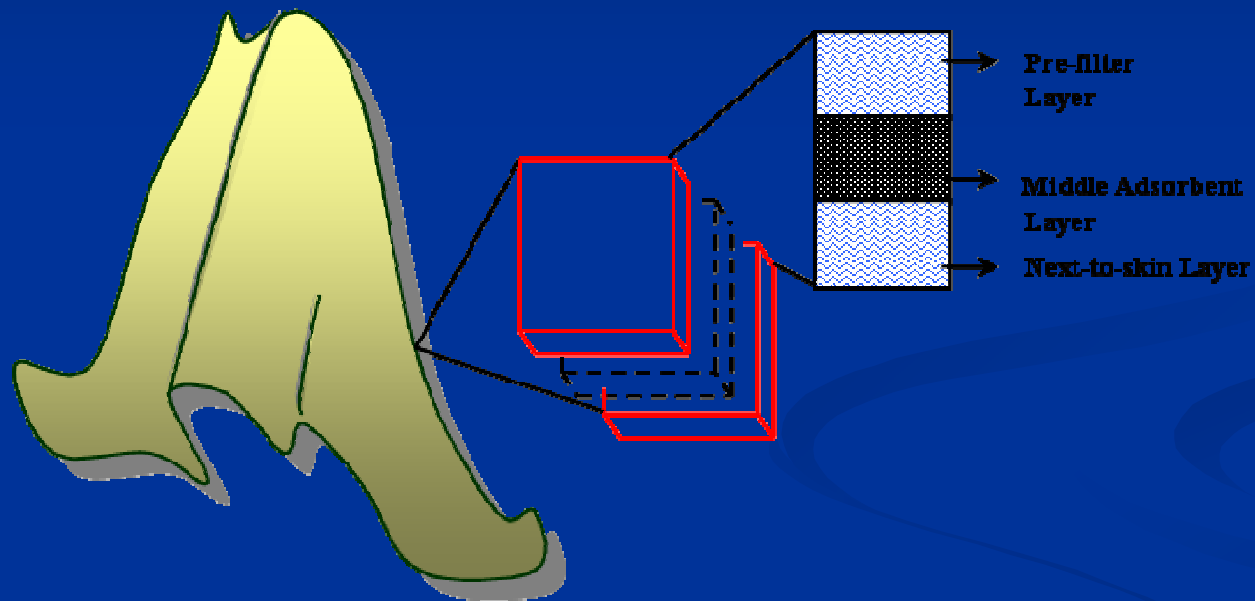



## Highly Efficient Flexible Decontamination Wipe



*Decon Wipe Drapes Around the Arm*



*Decon Wipe Cleans the Elbow*



*Decon Wipe Cleans the Intricate Part of an Automobile*



*Decon Wipe Drapes Around the Corner of a Table*



## *Adsorbent Medium: Activated Carbon Fabrics*



*Advantages of activated carbon fabrics include:*

*Excellent adsorption capacity: Better than the conventional GAC*

*Easy in handling: Fibrous form of activated carbon is favored*

*Pore volume: Slight presence of mesopore volume and a uniform distribution of micro pores*



## SEM Images of the Decontamination Wipe

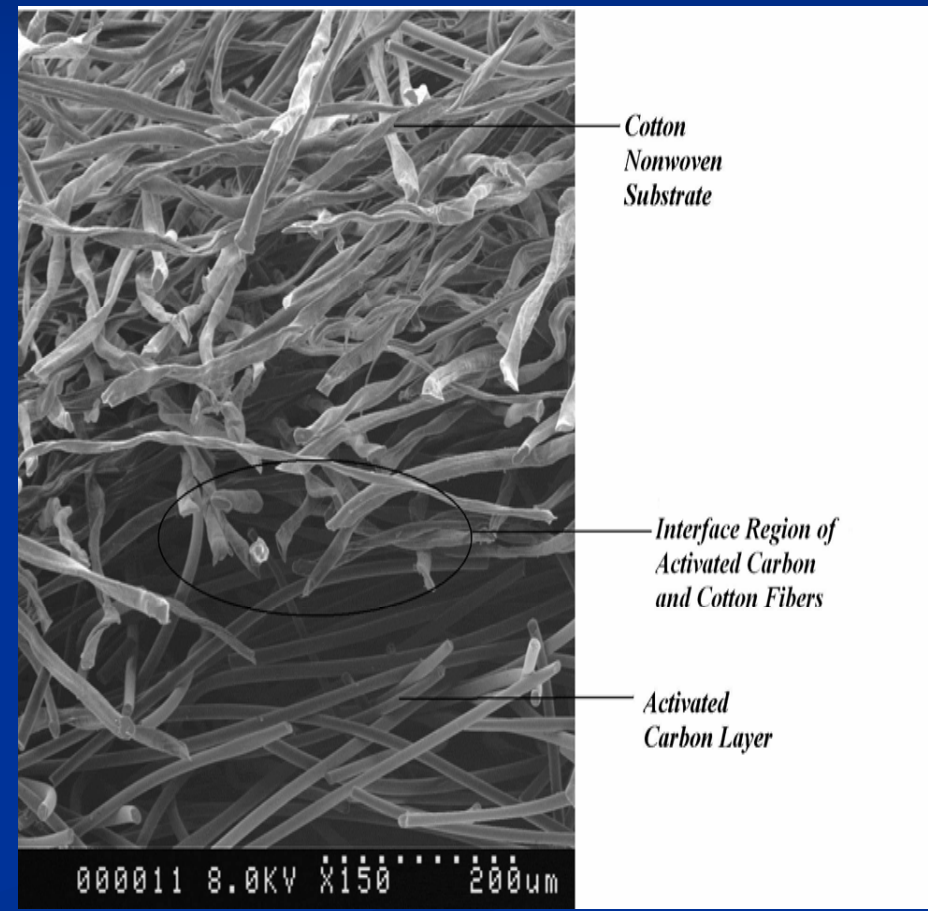
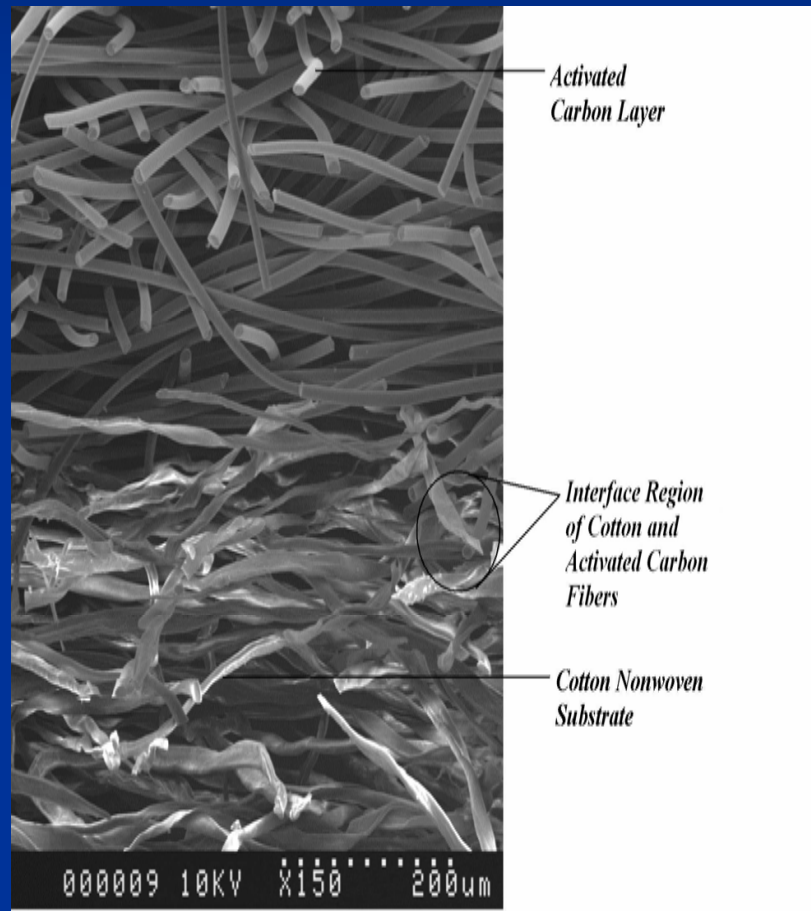



## *SEM Image of Individual Fibers in the Decontamination Wipe*

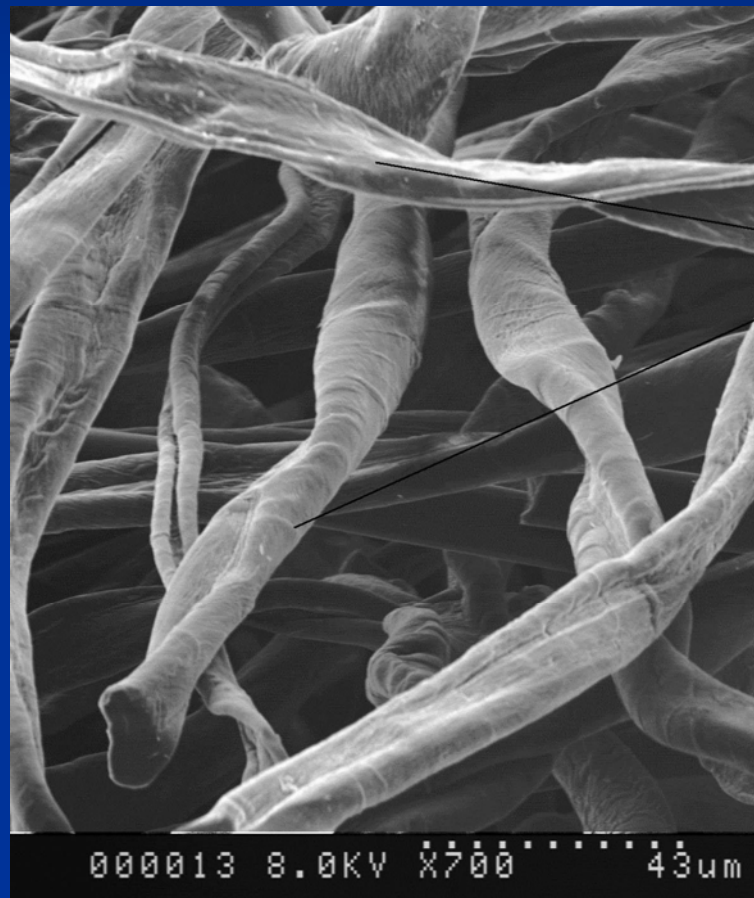

*Surface Image  
showing no Surface  
Damage to the  
Cotton Fibers due to  
Needlepunching*



## *Activated Carbon Fibers in the Composite*

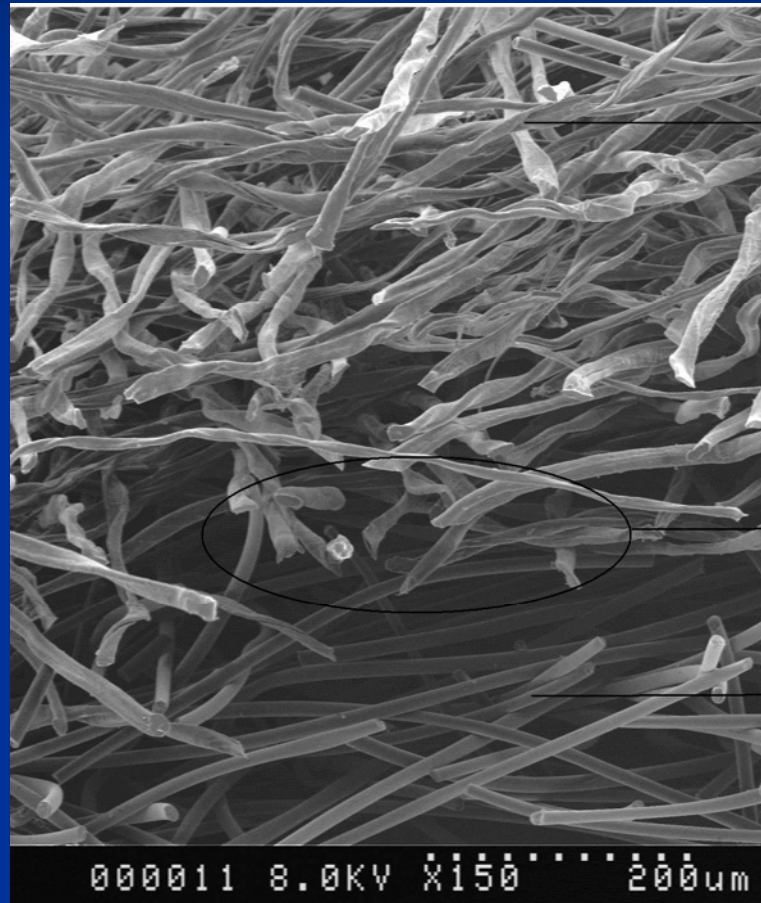

*Cotton  
Nonwoven  
Substrate*

*Interface Region of  
Activated Carbon  
and Cotton Fibers*

*Activated  
Carbon Layer*



## *Novel Features and Superior Characteristics of Nonwoven Wipes*



- The three-layered decontamination wipe will be flexible, drapable and soft*
- The decontamination wipe will be “next-to-skin” friendly, which is extremely important for personnel/human body decontamination*
- The decontamination wipe due to its flexibility will be able to follow the shapes and contours of intricate parts of human body and equipments*
- The top and bottom layers of the decontamination wipe provides the necessary structural coherence and enhanced strength*
- The nonwoven adsorption wipes will have improved adsorption characteristics due to needlepunching which will also increase the overall porosity of the wipe*
- The active adsorbing sites of the middle activated carbon adsorbent layers are not masked by the top and bottom layers as the three layers are needlepunched together which basically will enhance the porosity and surface area*



## *Novel Features and Superior Characteristics of Nonwoven Wipes*



- *The use of needlepunched top and bottom layers enhances the adsorption and filtration efficiencies due to the availability of pores and free fibers*
- *This is an important difference between the currently available rigid wipes that use polymer films that mask the active adsorption sites of the middle activated carbon*
- *The decontamination wipe has phenolic resin based activated carbon as the middle adsorbent layer that has superior properties such as flame retardancy than the cellulosic activated carbons*
- *The three-layered decon wipe will have improved mechanical strength and abrasion resistance*
- *The nonwoven technology is highly productive that enables the mass production of wipes at reduced production costs*



## *Results and Discussion*

*The three-layered needlepunched nonwoven composite has been shown offer necessary adsorption and filtration to toxic chemicals*

*A novel protocol has been developed to quantify the adsorption of toxic chemicals by the nonwoven wipe*

*A thermogravimetric analyzer has been successfully adopted to quantify the adsorption characteristics of nonwoven wipes*



# Thermogravimetric Analyzer



*Pyris 1 TGA Perkin Elmer*

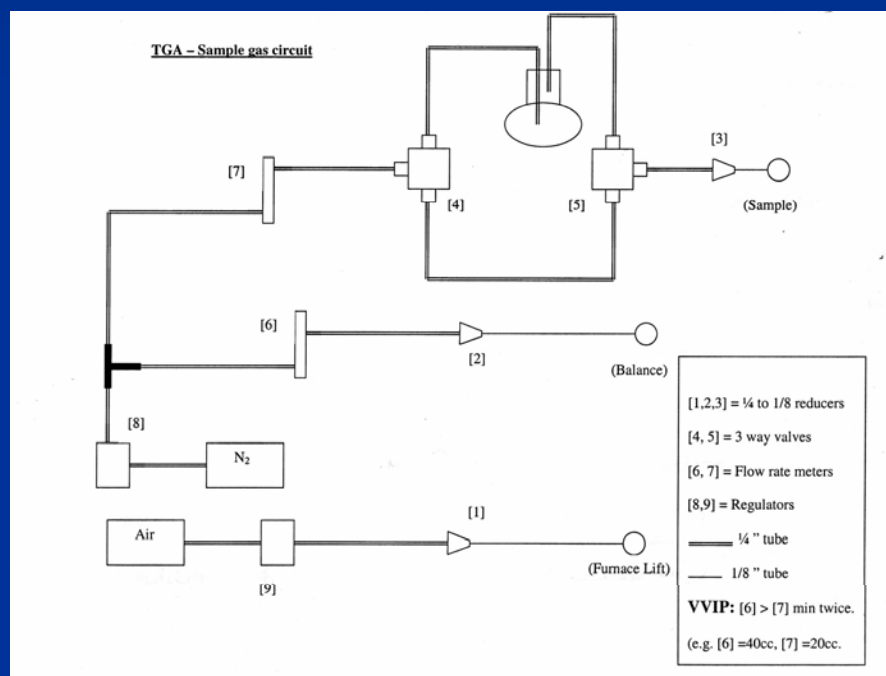

*Schematic Representation of TGA Exp. Set up*



## *TGA Experimental Method*



- *Fabric sample (TGA pan)*  
*Exposed to the resultant gas stream*  
*Total flow rate 20cc/min + 45cc/min*
- *Sample Exposed for 600 to 1000 min*  
*to confirm the saturation phenomenon*

*Change in mass of the fabric sample was recorded using "Pyris manager" data collection software until an equilibrium was reached*



## Adsorption Curve for Nonwoven Wipe

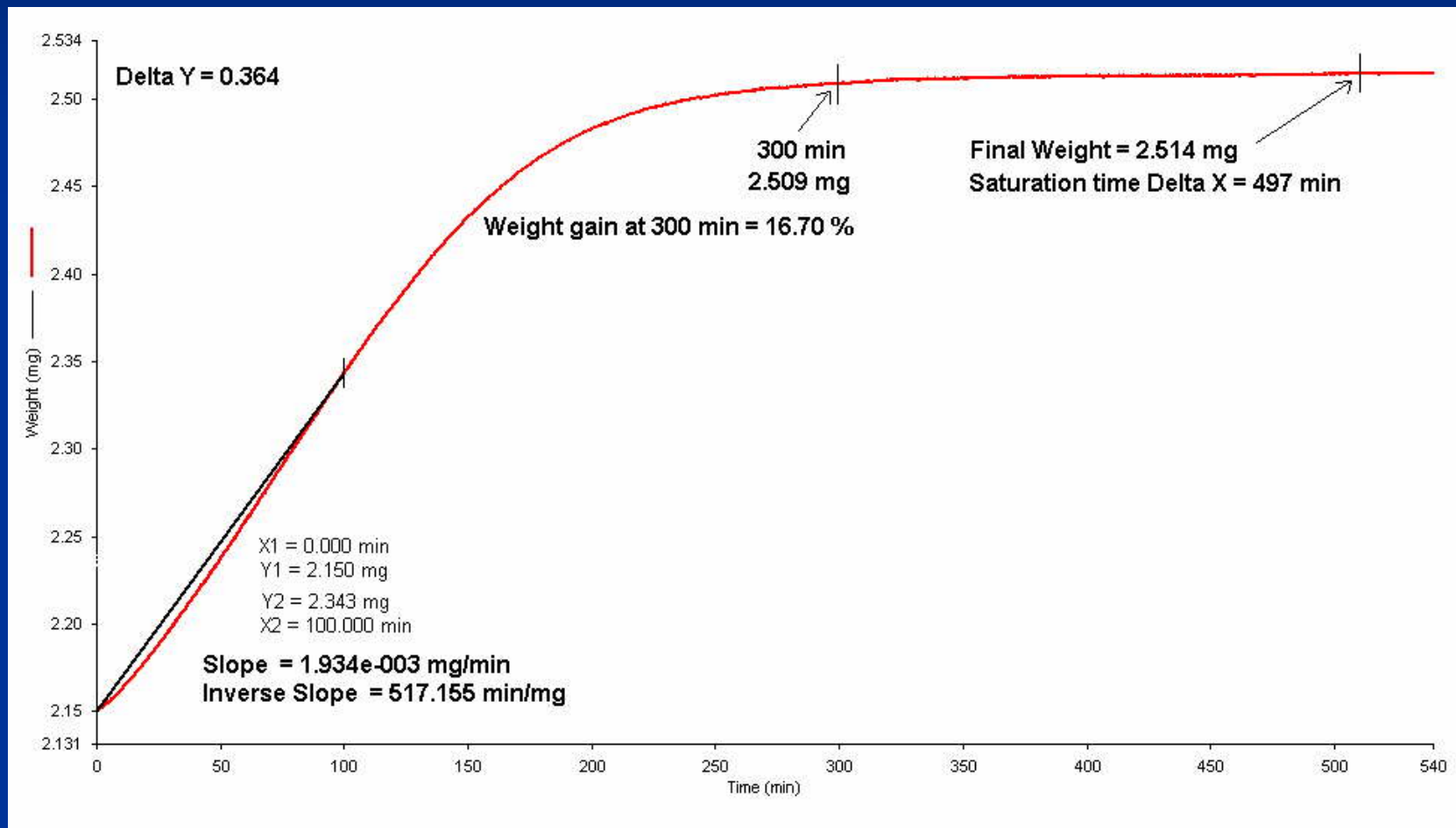



## *Adsorption Parameters*



*Four different adsorption parameters have been used to objectively quantify the decontamination efficiency of the wipe*

1. *Rate of Adsorption*
2. *Saturation Time*
3. *% Weight Gain at 300 min*
4. *Adsorption Capacity*



## *Details of Nonwoven Composites*



*Type I Composite 5092-25 (basket weave)*

*Type II Composite 507-25 (plain weave)*

*Type III Composite 507-15 (plain weave)*

*Type IV ACF 5092-25*

*Type V ACF 507-25*



## Adsorption Rate for Initial 100 Minutes

Adsorption Rate @ 100 min - Data for all runs for fabric Type I, Type II & Type III, Type IV & Type V

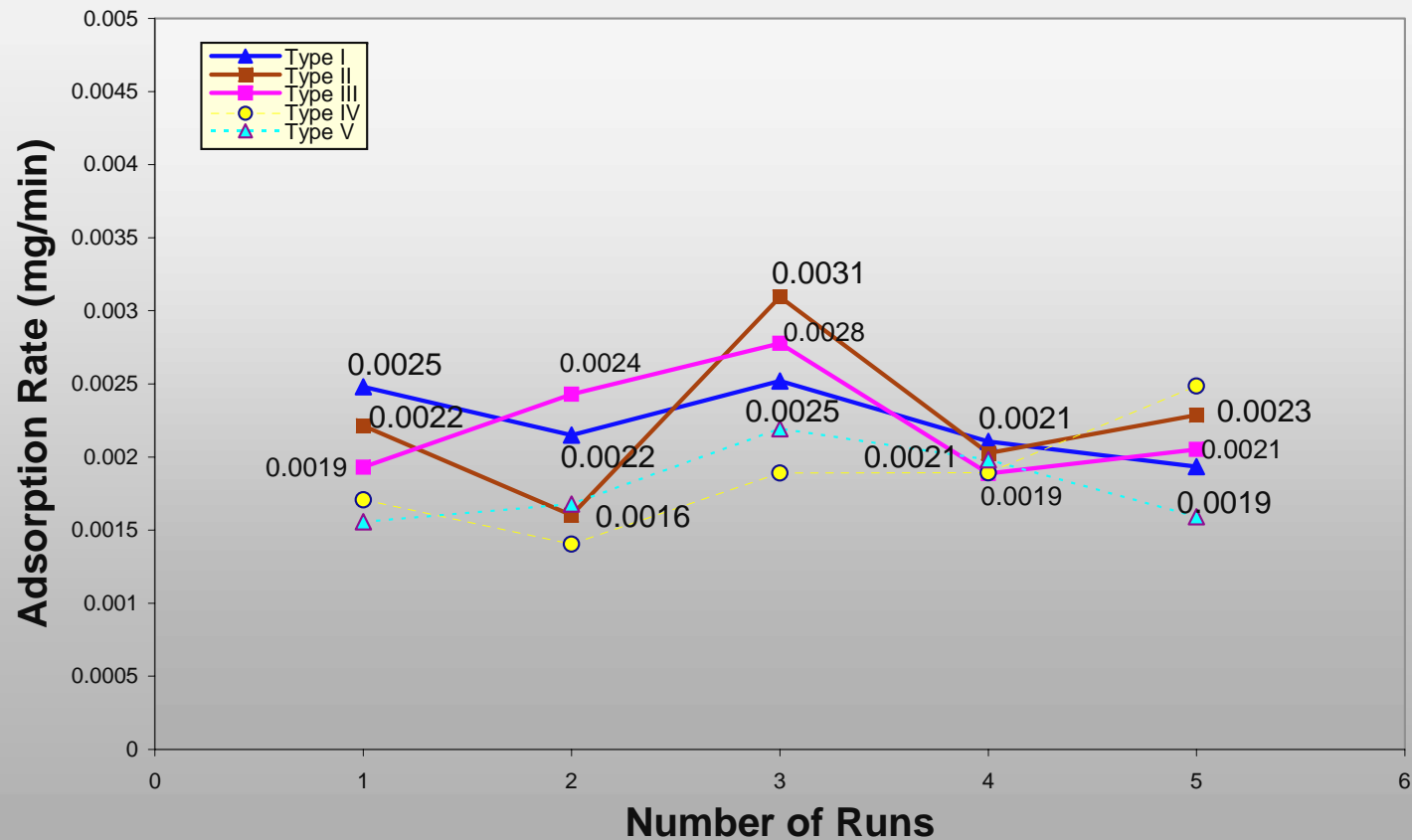



## Significant Results



*Rate of adsorption: All composite wipes performed more or less similar*

*Saturation Time: No difference among different composites (Type I – Type III)*

*Percentage Weight Gain: No difference among different composites (Type I – Type III)*



## News – Textile World April 2004



The Textile World Magazine  
April 2004

Quality  
Fabric  
Of The  
Month

# Toxic Clean-Up

A TIEHH research team has developed a nonwoven composite toxic chemical decontamination wipe using Fehrer's HI needleloom technology.

By  
Janet Bealer Rodle,  
Assistant Editor

#### CONTACTS:

For more information about TIEHH's research project, contact Seshadri Ramkumar, Ph.D., (806) 885-0228; sramkumar@ttu.edu.

Go on-line to  
[TextileWorld.com](http://TextileWorld.com)  
for archived  
Quality Fabric  
articles.

Researchers at The Institute for Environmental and Human Health at Texas Tech University (TIEHH), Lubbock, Texas, have developed a flexible, drapable nonwoven composite substrate for a decontamination wipe that is effective in neutralizing toxic chemicals used in chemical warfare and pesticides. Seshadri Ramkumar, Ph.D., who heads up the research project, said a patent has been applied for in connection with this application. The research is supported by a grant from the US Army Research, Development and Engineering Command, Aberdeen Proving Ground, Md.

The composite was developed using Austria-based Fehrer AG's HI needleloom technology. The HI system uses an oblique, asymmetrically curved needling zone and straight movement of the barbed needles, causing them to penetrate through the fiber mat at an angle, pushing from opposite sides to interlock the fibers in a criss-cross pattern. Ramkumar said the process requires fewer needle penetrations than traditional needling processes and provides superior web properties, and the technology enhances the construction of composite and hybrid products. He also said the process is very practical and cost-effective. "Needlepunch productivity is higher than weaving, plus intermediate processes such as spinning are eliminated, which lowers production costs," he explained.

The composite substrate developed for the wipes comprises a needlepunched prefilter layer, an adsorption layer and a

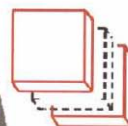
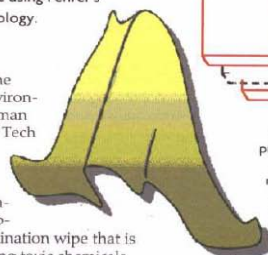

The substrate's three layers are needle-punched together, making it more flexible and drapable than a bonded composite.

Nonwoven  
pre-filter layer  
Adsorbent  
middle layer  
Nonwoven  
base layer

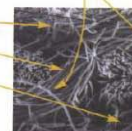

needlepunched base layer. The three layers are needlepunched together in a final interlocking. "The resulting fabric needs no other means of bonding, which would make it stiff. That is the beauty of needle-punching," Ramkumar said, noting that the fabric's drapability allows it to follow body contours and get into crevices of objects that must be decontaminated. He also said the fabric could become the inner layer of a protective suit.

The prefilter and base layers contain a "skin-friendly" fiber such as cotton or polyester, Ramkumar said. "In the middle layer, I have used a special activated fiber, which gives adsorption and also is flame-retardant," he continued. "We have proved that the top and bottom layers do not affect the adsorption/protection characteristics of the middle layer. My Ph.D. student Utkarsh 'Kar' Sata has worked under my supervision and proved this statistically."

Ramkumar is using the HI technology to develop a variety of other fabrics as well. He is receiving support from the National Cotton Council, Cotton Incorporated and the Texas Food and Fibers Commission for the development of lightweight and ultra-lightweight cotton and natural fiber nonwovens for value-added products. 



## General Conclusions

- *Three-layered composite can serve as an effective adsorbent wipe against toxic chemicals*
- *Thermo-gravimetric analyzer is a good analytical tool for quantifying the adsorption characteristics*
- *The needlepunching nonwoven technology is a viable method for developing flexible decontamination wipes*



## *Acknowledgements*



*The work has been funded by the US Army Research,  
Development and Engineering Command, Cotton  
Incorporated, National Cotton Council and Texas Food and  
Fibers Commission*

Quality  
Fabric  
Of The  
Month

# Toxic Clean-Up

By  
Janet Bealer Rodie,  
Assistant Editor

A TIEHH research team has developed a nonwoven composite toxic chemical decontamination wipe using Fehrer's H1 needleloom technology.

Researchers at The Institute for Environmental and Human Health at Texas Tech University (TIEHH), Lubbock, Texas, have developed a flexible, drapable nonwoven composite substrate for a decontamination wipe that is effective in neutralizing toxic chemicals used in chemical warfare and pesticides. Seshadri Ramkumar, Ph.D., who heads up the research project, said a patent has been applied for in connection with this application. The research is supported by a grant from the US Army Research, Development and Engineering Command, Aberdeen Proving Ground, Md.

The composite was developed using Austria-based Fehrer AG's H1 needleloom technology. The H1 system uses an oblique, asymmetrically curved needling zone and straight movement of the barbed needles, causing them to penetrate through the fiber mat at an angle, pushing from opposite sides to interlock the fibers in a criss-cross pattern. Ramkumar said the process requires fewer needle penetrations than traditional needling processes and provides superior web properties, and the technology enhances the construction of composite and hybrid products. He also said the process is very practical and cost-effective. "Needlepunch productivity is higher than weaving, plus intermediate processes such as spinning are eliminated, which lowers production costs," he explained.

The composite substrate developed for the wipes comprises a needlepunched prefilter layer, an adsorption layer and a

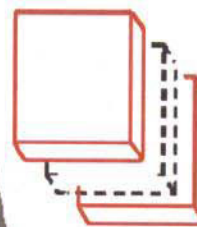

The substrate's three layers are needle-punched together, making it more flexible and drapable than a bonded composite.

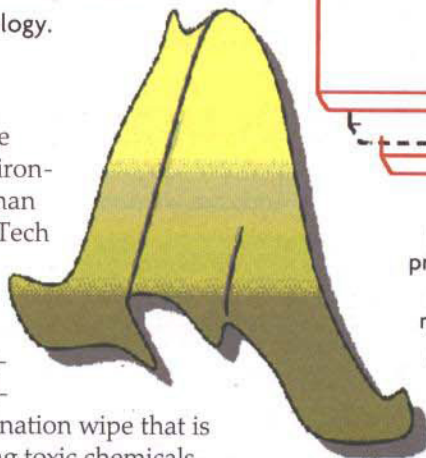

Nonwoven pre-filter layer  
Adsorbent middle layer  
Nonwoven base layer

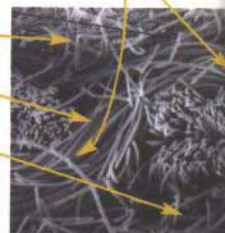

needlepunched base layer. The three layers are needlepunched together in a final interlocking. "The resulting fabric needs no other means of bonding, which would make it stiff. That is the beauty of needlepunching," Ramkumar said, noting that the fabric's drapability allows it to follow body contours and get into crevices of objects that must be decontaminated. He also said the fabric could become the inner layer of a protective suit.

The prefilter and base layers contain a "skin-friendly" fiber such as cotton or polyester, Ramkumar said. "In the middle layer, I have used a special activated fiber, which gives adsorption and also is flame-retardant," he continued. "We have proved that the top and bottom layers do not affect the adsorption/protection characteristics of the middle layer. My Ph.D. student Utkarsh 'Kar' Sata has worked under my supervision and proved this statistically."

Ramkumar is using the H1 technology to develop a variety of other fabrics as well. He is receiving support from the National Cotton Council, Cotton Incorporated and the Texas Food and Fibers Commission for the development of lightweight and ultra-lightweight cotton and natural fiber nonwovens for value-added products. **TW**

#### CONTACTS:

For more information about TIEHH's research project, contact Seshadri Ramkumar, Ph.D., (806) 885-0228; s.ramkumar@ttu.edu.

Go on-line to  
[TextileWorld.com](http://TextileWorld.com)  
for archived  
Quality Fabric  
articles.