

---

# AGENTFATE

---

## **Evaporation of Chemical Warfare Agent HD on Glass Surface Under Various Environmental Conditions**

**Seok H. Hong and Kenneth B. Sumpter  
U.S. Army Edgewood Chemical Biological Center  
Robert Nickol and Wendel Shuely  
Geo-Centers, Inc.**

15 November 2004

# Report Documentation Page

*Form Approved*  
*OMB No. 0704-0188*

Public reporting burden for the collection of information is estimated to average 1 hour per response, including the time for reviewing instructions, searching existing data sources, gathering and maintaining the data needed, and completing and reviewing the collection of information. Send comments regarding this burden estimate or any other aspect of this collection of information, including suggestions for reducing this burden, to Washington Headquarters Services, Directorate for Information Operations and Reports, 1215 Jefferson Davis Highway, Suite 1204, Arlington VA 22202-4302. Respondents should be aware that notwithstanding any other provision of law, no person shall be subject to a penalty for failing to comply with a collection of information if it does not display a currently valid OMB control number.

1. REPORT DATE <b>15 NOV 2004</b>	2. REPORT TYPE <b>N/A</b>	3. DATES COVERED <b>-</b>	
4. TITLE AND SUBTITLE <b>Evaporation of Chemical Warfare Agent HD on Glass Surface Under Various Environmental Conditions</b>		5a. CONTRACT NUMBER	
		5b. GRANT NUMBER	
		5c. PROGRAM ELEMENT NUMBER	
6. AUTHOR(S)		5d. PROJECT NUMBER	
		5e. TASK NUMBER	
		5f. WORK UNIT NUMBER	
7. PERFORMING ORGANIZATION NAME(S) AND ADDRESS(ES) <b>U.S. Army Edgewood Chemical Biological Center, APG, MD</b>		8. PERFORMING ORGANIZATION REPORT NUMBER	
9. SPONSORING/MONITORING AGENCY NAME(S) AND ADDRESS(ES)		10. SPONSOR/MONITOR'S ACRONYM(S)	
		11. SPONSOR/MONITOR'S REPORT NUMBER(S)	
12. DISTRIBUTION/AVAILABILITY STATEMENT <b>Approved for public release, distribution unlimited</b>			
13. SUPPLEMENTARY NOTES <b>See also ADM001849, 2004 Scientific Conference on Chemical and Biological Defense Research. Held in Hunt Valley, Maryland on 15-17 November 2004 . , The original document contains color images.</b>			
14. ABSTRACT			
15. SUBJECT TERMS			
16. SECURITY CLASSIFICATION OF:			17. LIMITATION OF ABSTRACT
a. REPORT <b>unclassified</b>	b. ABSTRACT <b>unclassified</b>	c. THIS PAGE <b>unclassified</b>	<b>UU</b>
			18. NUMBER OF PAGES <b>50</b>
			19a. NAME OF RESPONSIBLE PERSON

# ABSTRACT

Environmental fate of the chemical warfare agents (CWA) is receiving increasing attention, since the evaluation of the contact or vapor hazard is the critical input for models employed to support decisions to determine the individual as well as collective protection level of the combatants. Once released, CWA might evaporate and be carried by the wind, sorb into the surface material, or both. This can be a function of not only CWA, its droplet size and the surface substrate but also the environmental factors such as temperature, relative humidity, and wind speed. This work was carried out to establish a better understanding of the influence of each factor to the fate of CWA. Two different microbalances, configured in a wind-tunnel geometry, were employed to measure the weight loss of HD as a function of time from glass surface under various environmental conditions.

# Instrumentation for Microbalance Wind Tunnel

- Dual beam, horizontal microbalance with simultaneous differential thermal analysis (TA Model SDT-Q600)
- Evolved gas geometry, vertical microbalance (TA Model TGA-2950)

Figure 1. TA Vertical Microbalance with Evolved Gas Option Allowing Use as an Horizontal Wind Tunnel



Figure 2. Horizontal Wind Tunnel Mode of the TA Model 2950 Microbalance

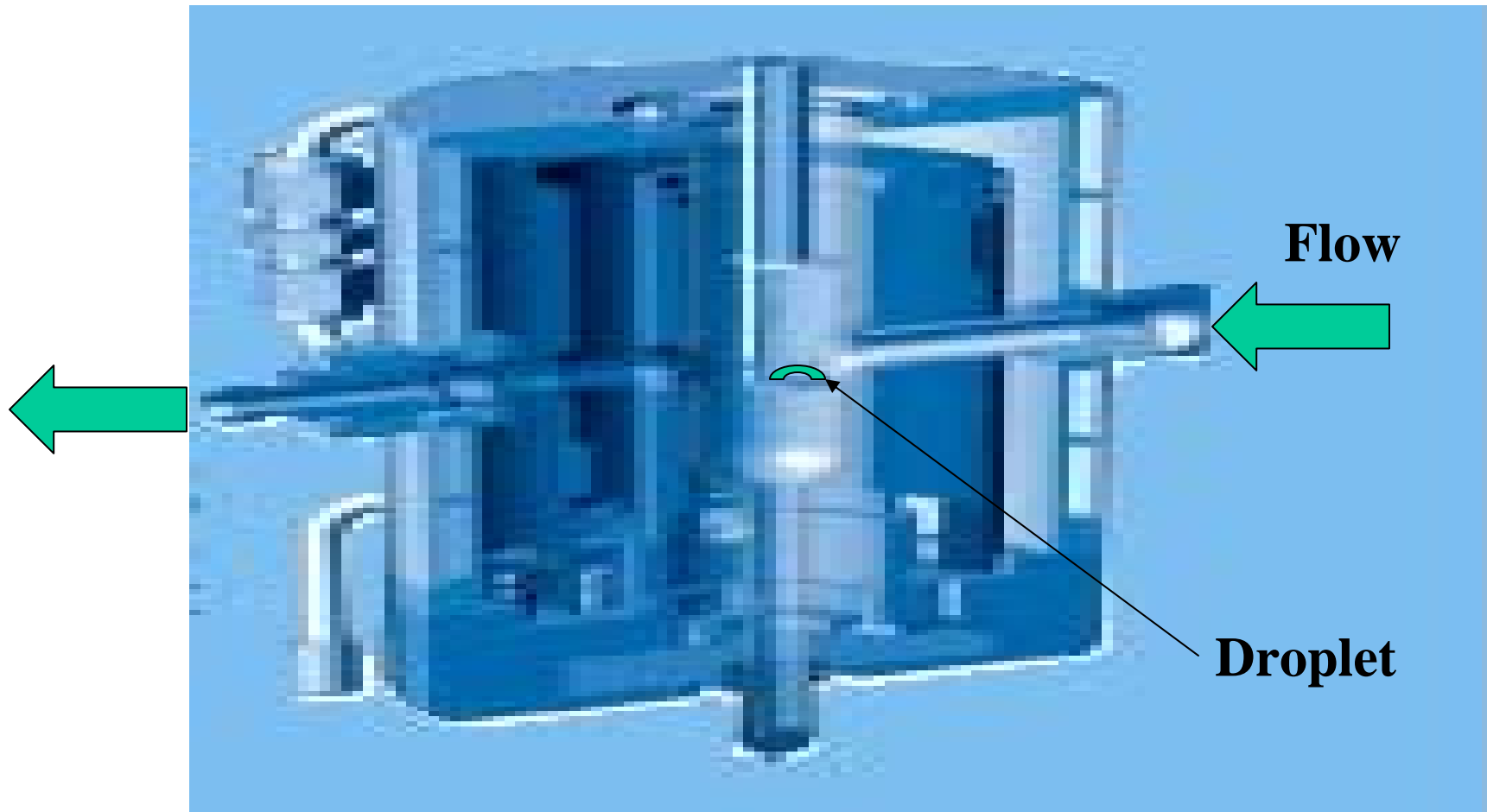
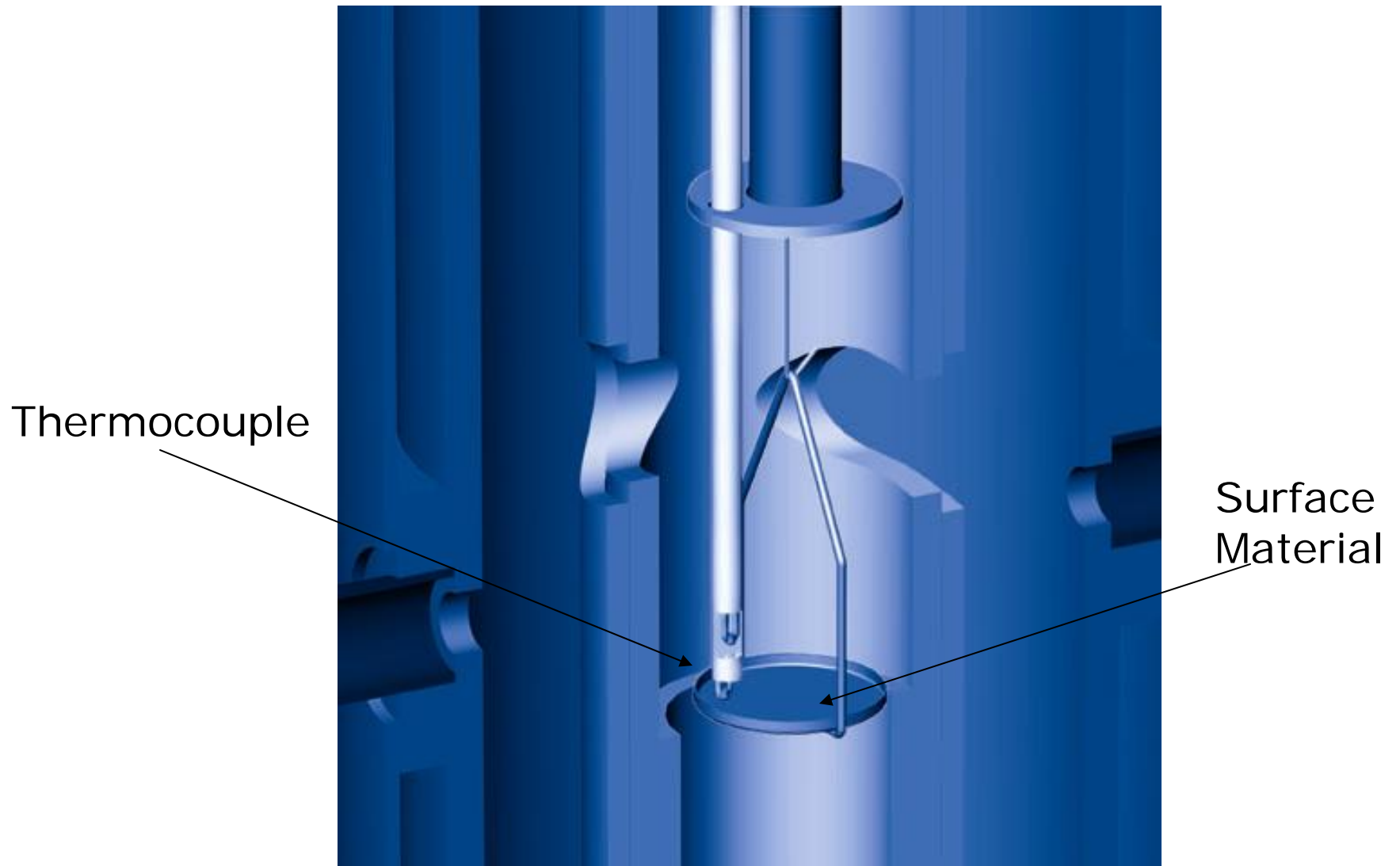

Figure 3. Sample/Control Thermocouple:  
TA Model 2950



# Figure 4. Q600 Simultaneous DSC-TGA



Figure 5. Horizontal Microbalance TA Q600 Showing Sample and Reference Holder

**Q600 Reactive Gas Tubing**

---

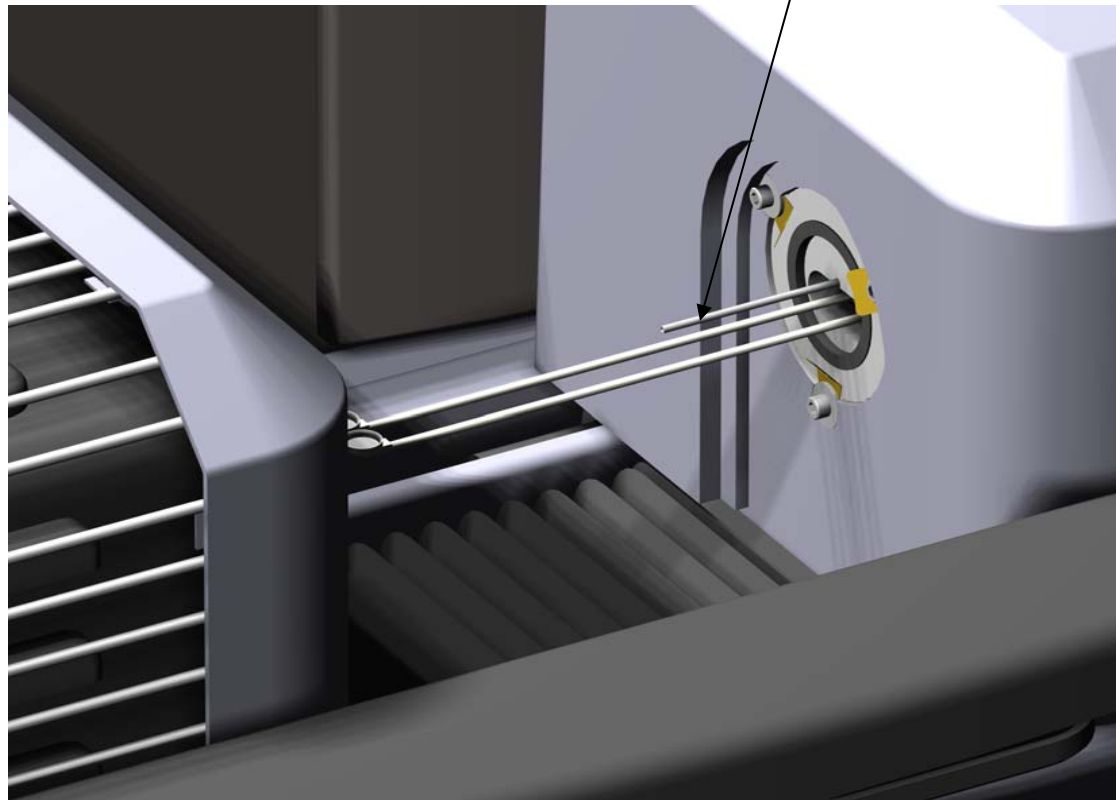

# Figure 6. TA Model Q600

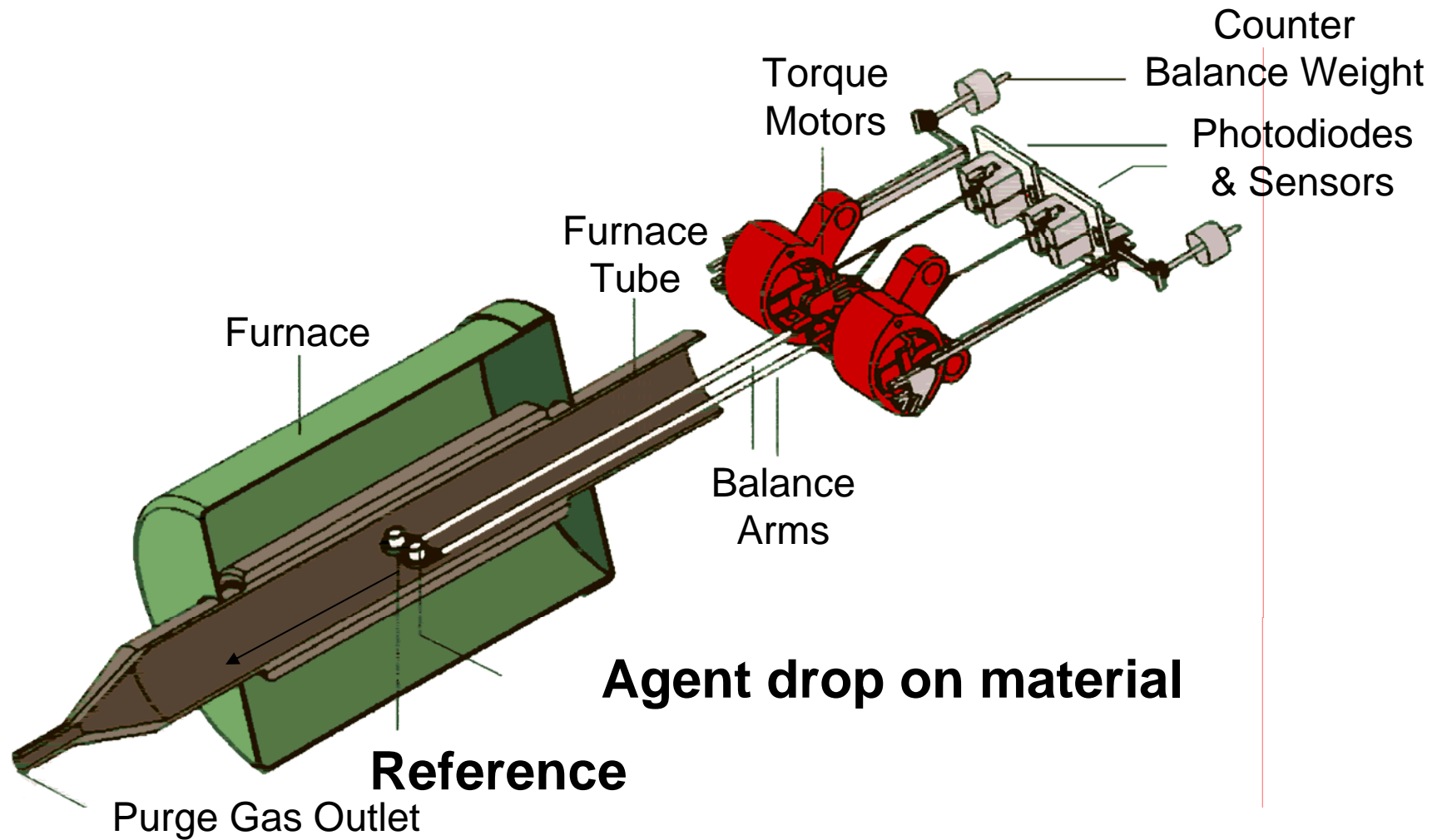

# Surface Material

- COVER GLASS
  - 5mm (UNCLEANED AND CLEANED)
- WINDOW GLASS
  - 9mm for 2950 and 6mm for Q600 (CLEANED)
- TNO GLASS
  - 9mm for 2950 and 6mm for Q600 (CLEANED)
- Aluminum
  - Unpainted Floor of Aluminum 2024 on C17 Cargo Aircraft (from Tim Provens, WPAFB)
- Aggregate
  - Alabama Limestone

# Experimental

- Temp: 25, 30, 40, and 55 C.
- Relative Humidity: 0 – 50%
- Drop Size: 0.91, 3.5 and 6 uL
- Flow Rate: 100, 500 and 1000 mL/min
- Purity of HD were 97+ % by GC/TCD.

WEIGHT LOSS OF HD ON GLASS DISKS  
CLEANED VS NOT CLEANED  
@30C, 0% RH, 100mL/MIN FR

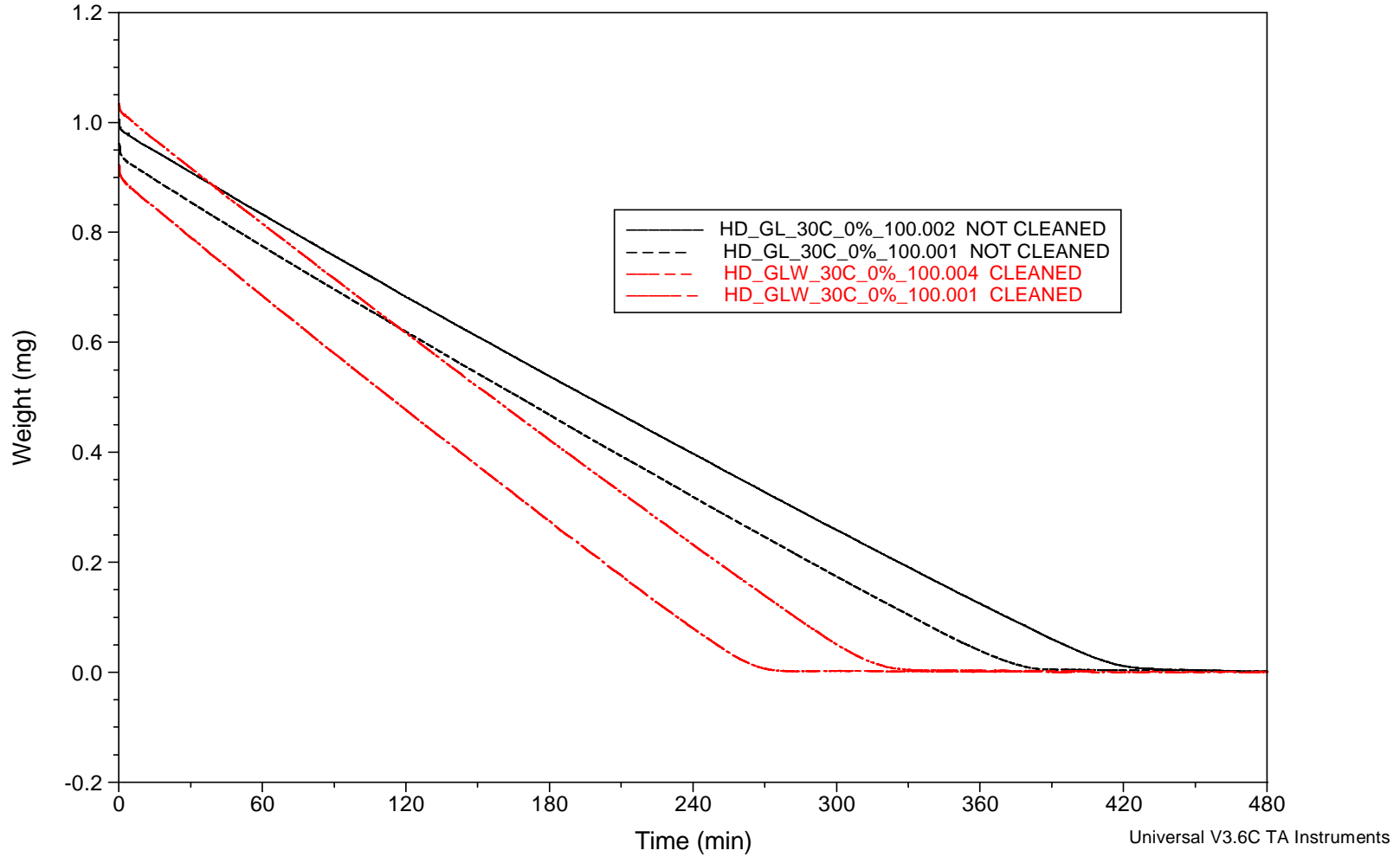

Figure 7. Comparison of HD Evaporation Rate from Glass (Cover)  
Cleaned vs Uncleaned  
@30 degrees C, 0% Relative Humidity, 100 mL/min Flow Rate

EFFECT OF FLOW RATE ON WEIGHT LOSS OF HD ON GLASS(P)  
@40 degreesC, 0% Relative Humidity

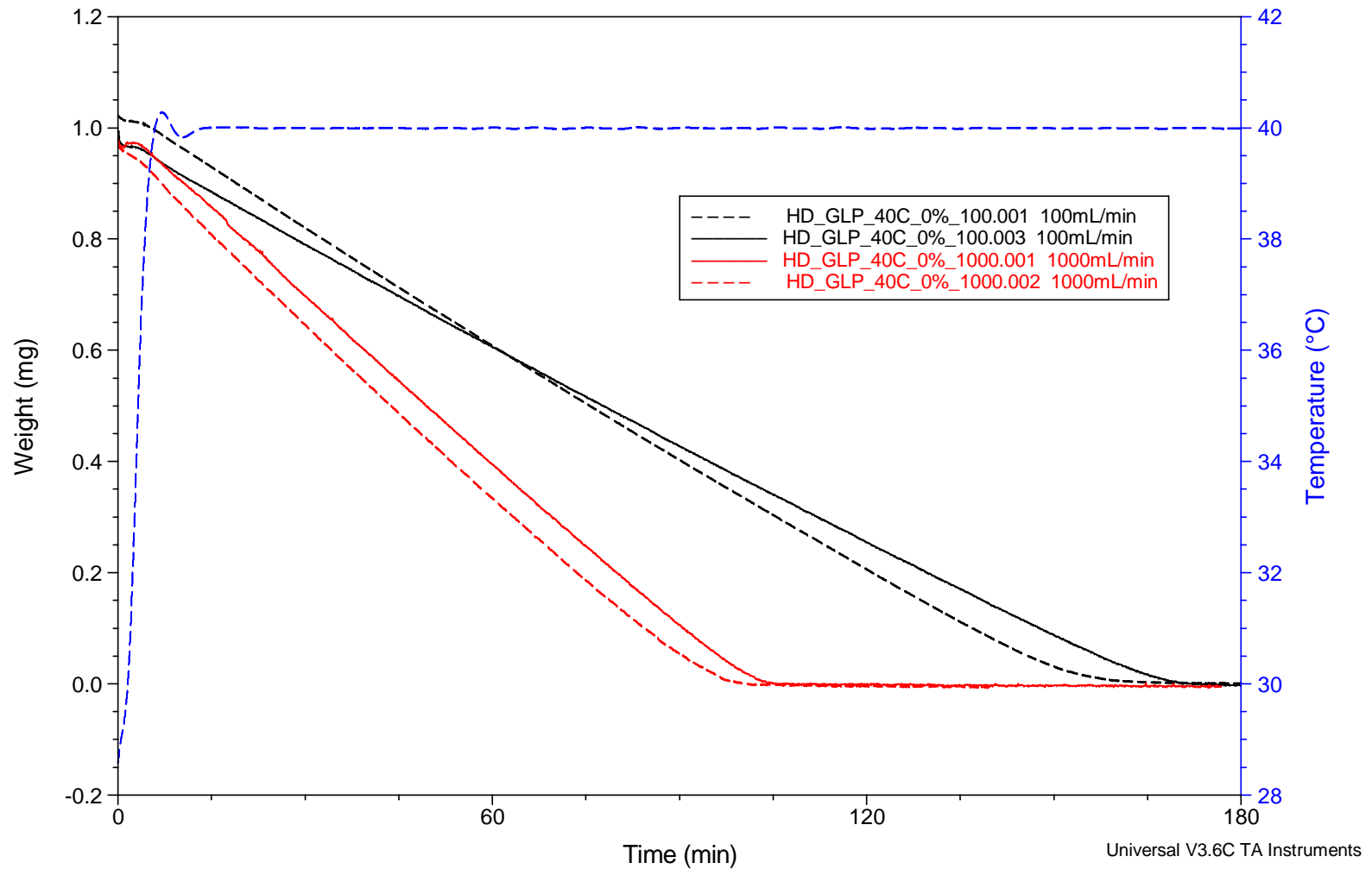

Figure 8. Comparison of HD Evaporation Rate from Glass (Window) at Various Flow Rates:  
@40 degrees C, 0% Relative Humidity

EFFECT OF TEMPERATURE ON WEIGHT LOSS OF HD ON GLASS(P)  
RH 0%, FLOW RATE 100mL/MIN (2950)

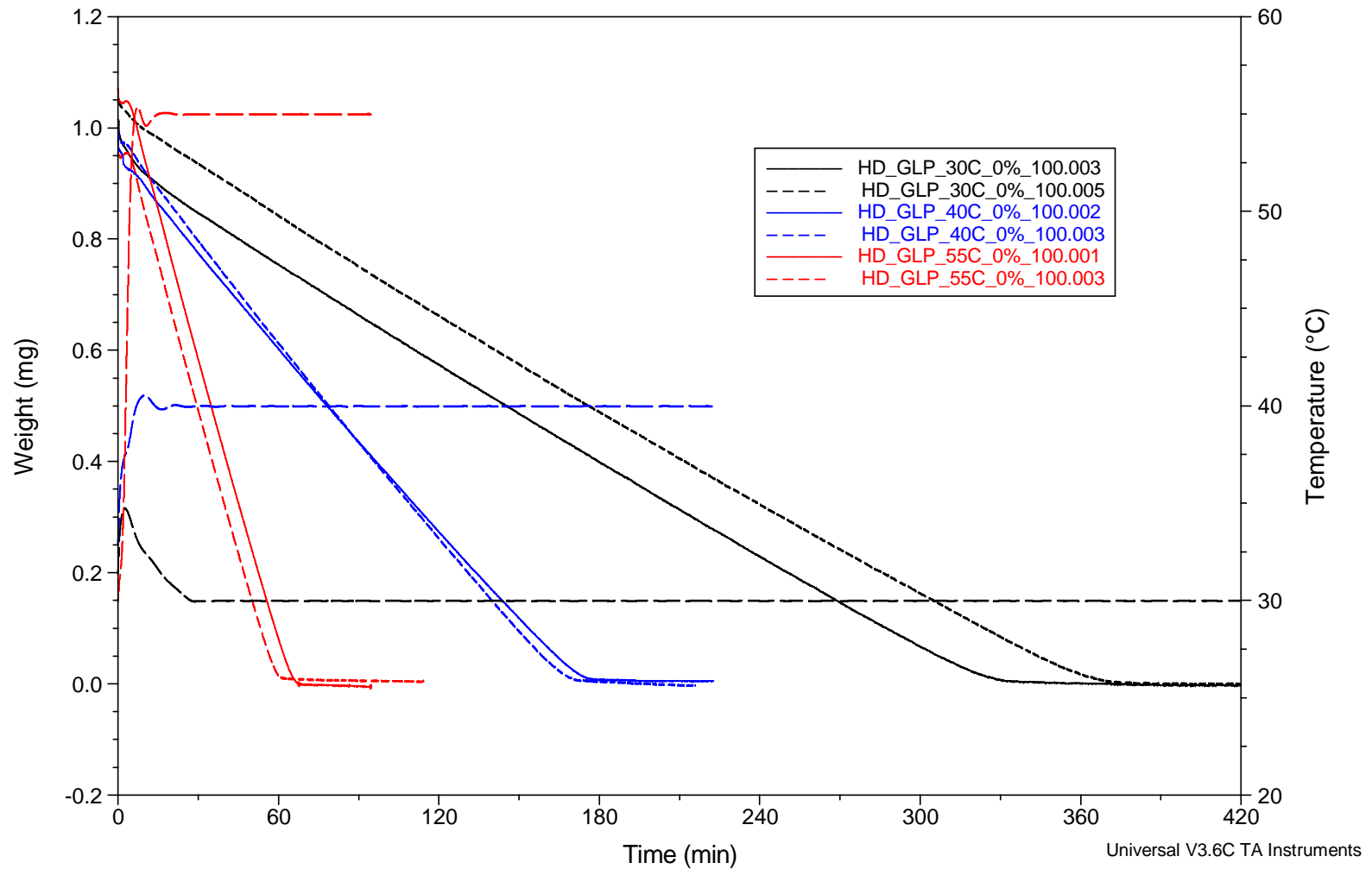

Figure 9. Comparison of HD Evaporation Rate from Glass(Window) at Various Temperatures: 0% Relative Humidity, 100 mL/min Flow Rate

EFFECT OF DROP SIZE ON WEIGHT LOSS OF HD ON GLASS(P)  
@30C, 0% RH, 100mL/MIN (2950)

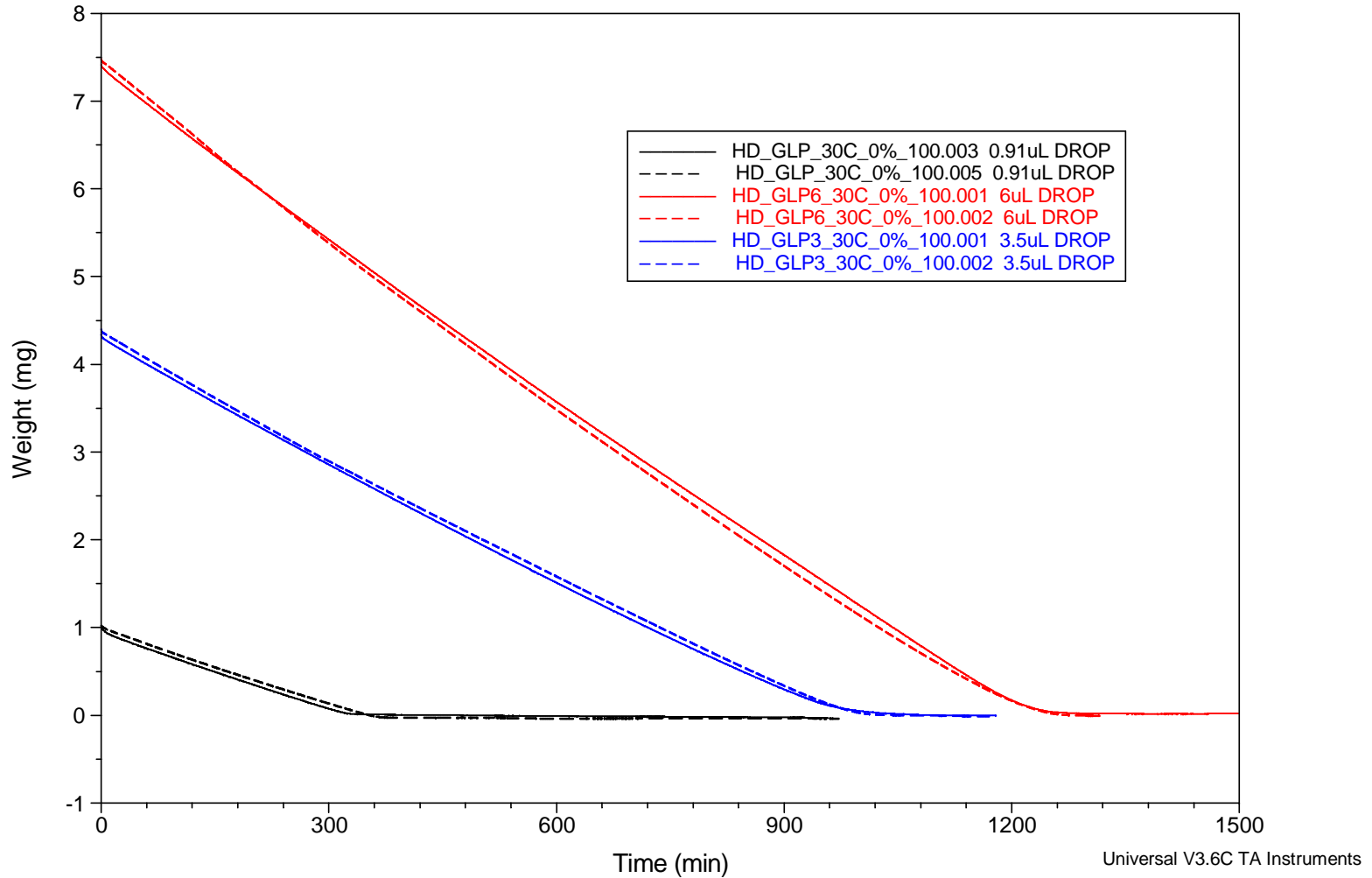

Figure 10. Comparison of HD Evaporation Rate from Glass (Window) from Various Drop Sizes:  
@30 degrees C, 0% Relative Humidity, 100 mL/min Flow Rate

EFFECT OF HUMIDITY ON WEIGHT LOSS OF HD ON GLASS(P)  
@40C, 500mL/MIN

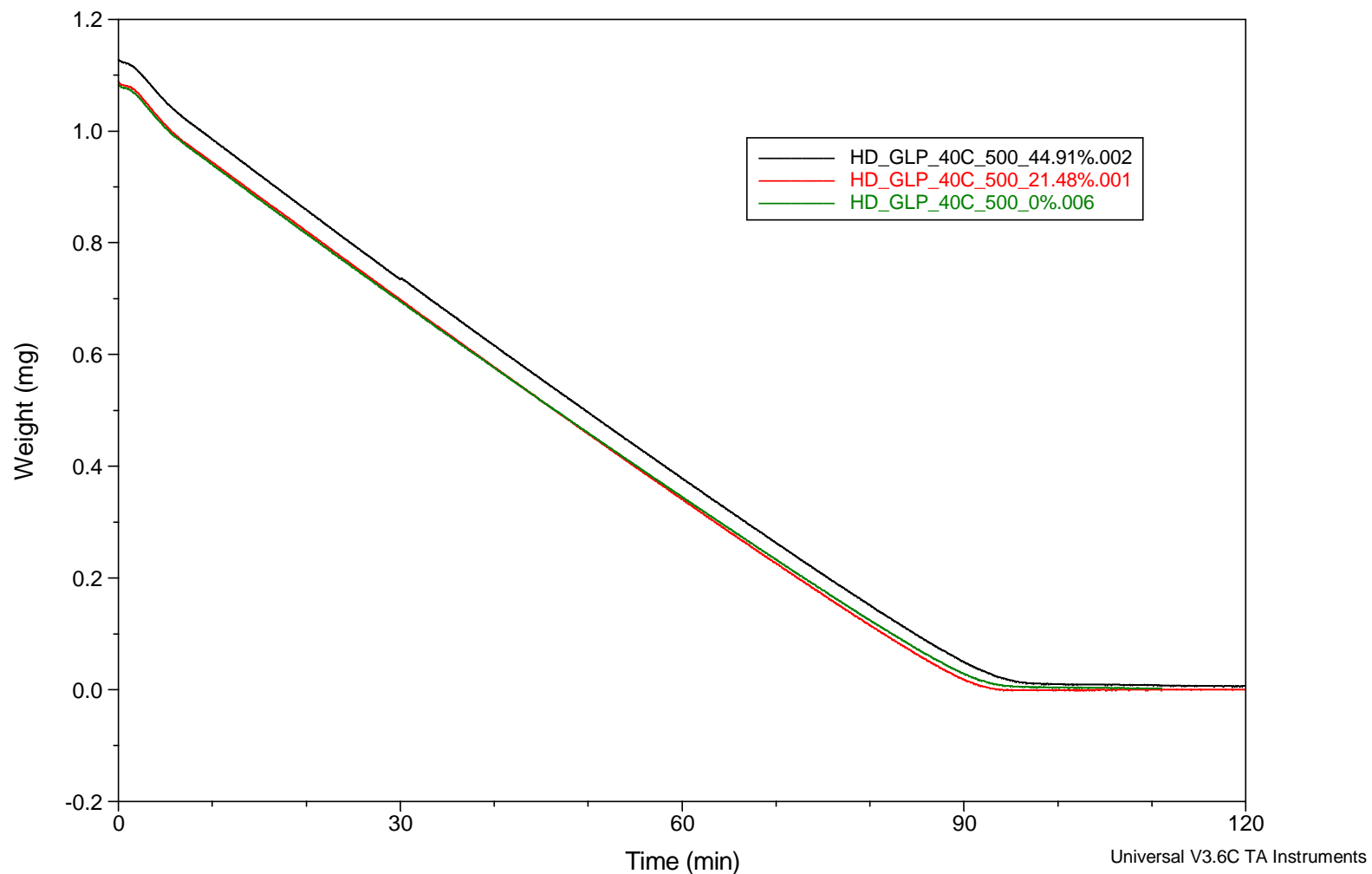

Figure 11. Comparison of HD Evaporation Rate from Glass (Window) at Various Relative Humidities: @40 degrees C, 500 mL/min Flow Rate

2950 HD ON GLT AT VARIOUS TEMP  
(0%, 1000mL/min)

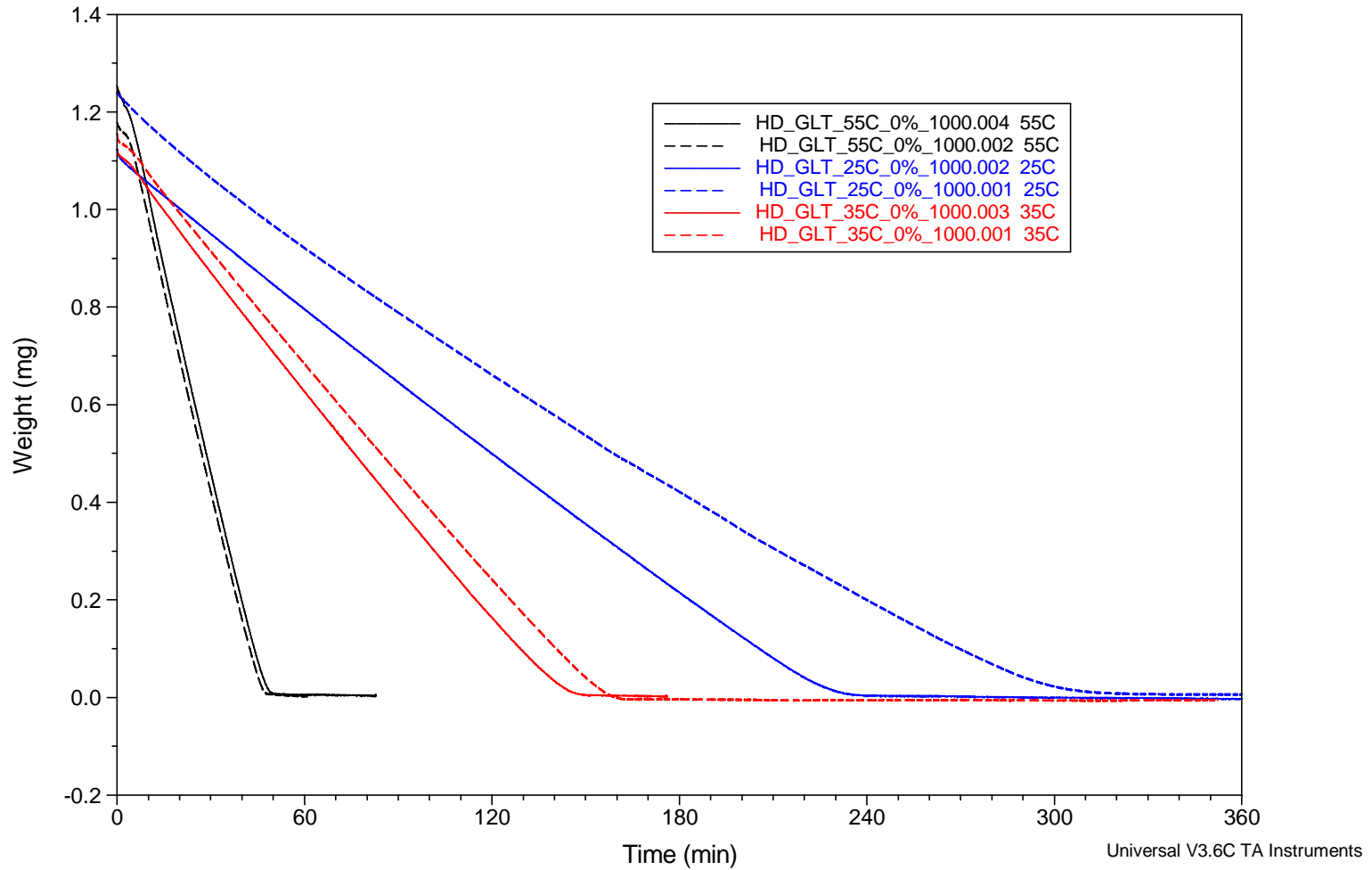

Figure 12. Comparison of HD Evaporation Rate from Glass (TNO) at Various Temperatures: 0% Relative Humidity, 1000 mL/min Flow Rate

HD ON GLASS: TNO VS WINDOW  
@30C, 1000mL/min FR, 0% RH

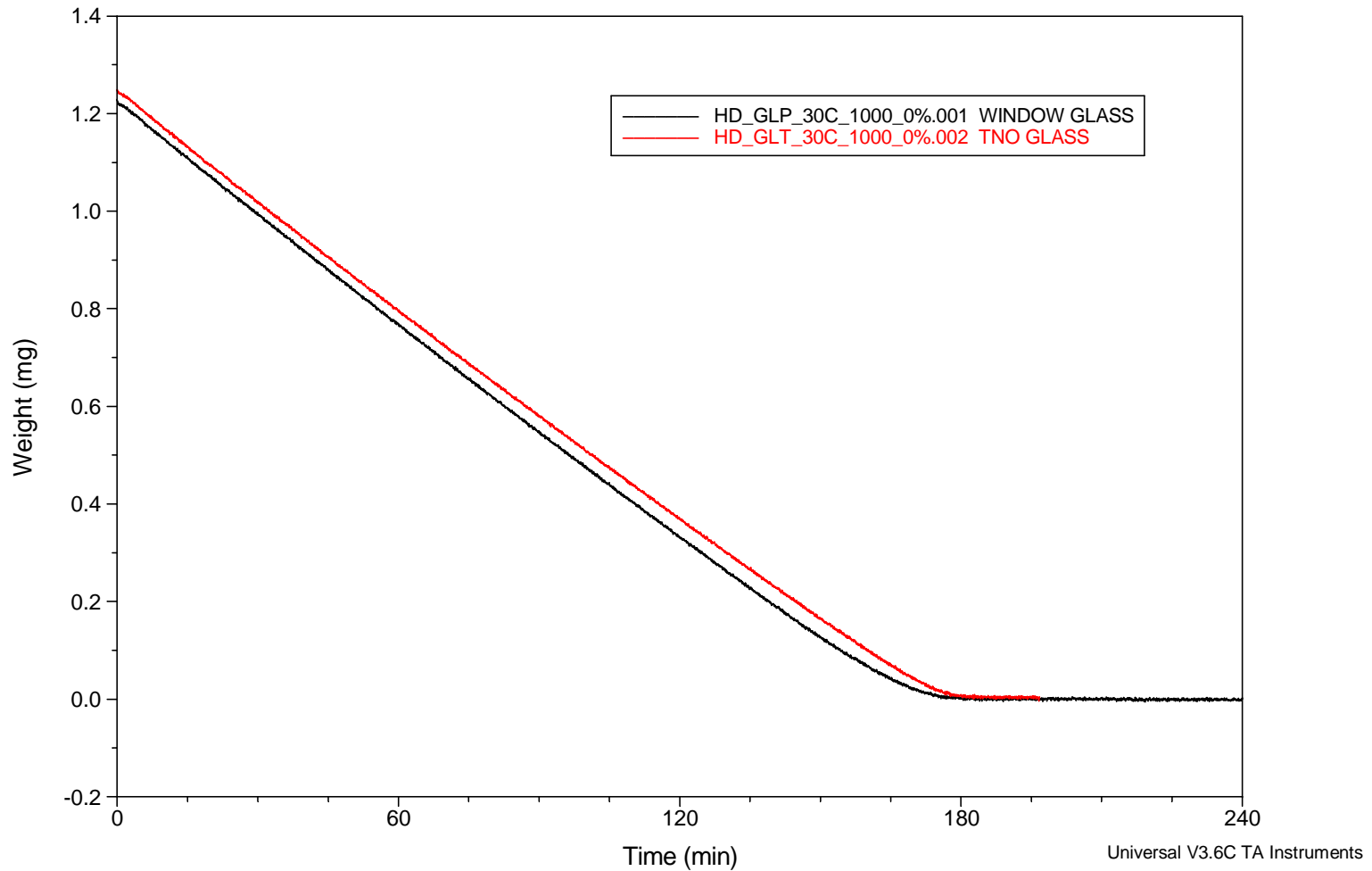

Figure 13. Comparison of HD Evaporation Rate from Glass  
TNO Glass vs Window Glass  
@30 degrees C, 0% Relative Humidity, 100 mL/min Flow Rate

WEIGHT LOSS OF HD ON GLASS (TNO)  
@35 degrees C, 0% RH, 1000mL/min FR

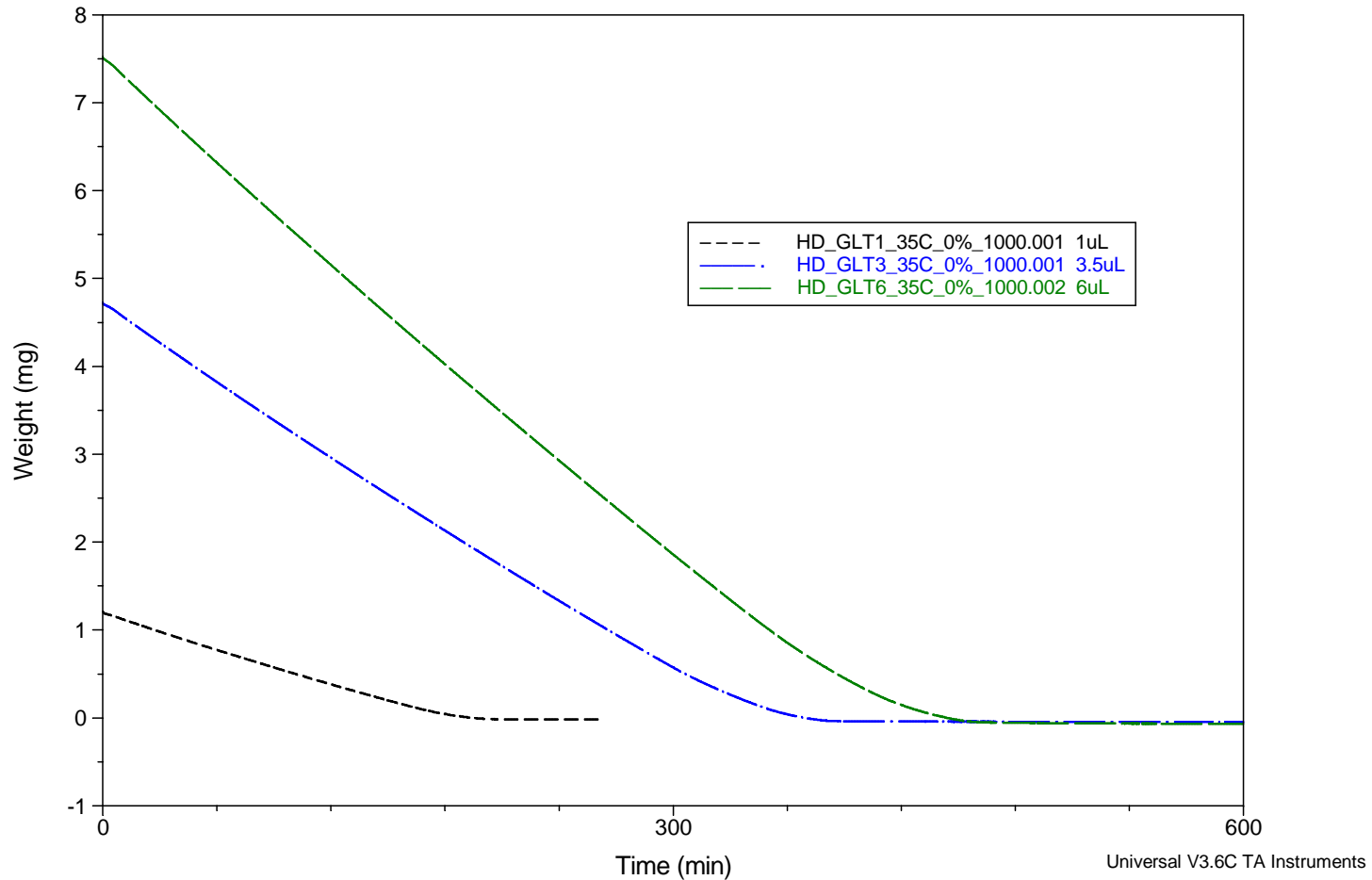

Figure 14. Comparison of HD Evaporation Rate from Glass (TNO):  
Drop Size Effect  
@35 degrees C, 0% Relative Humidity, 1000 mL/min Flow Rate

WEIGHT LOSS OF HD : GLASS VS ALUMINUM  
@30 degrees C, 0% RH, 100mL/min FR

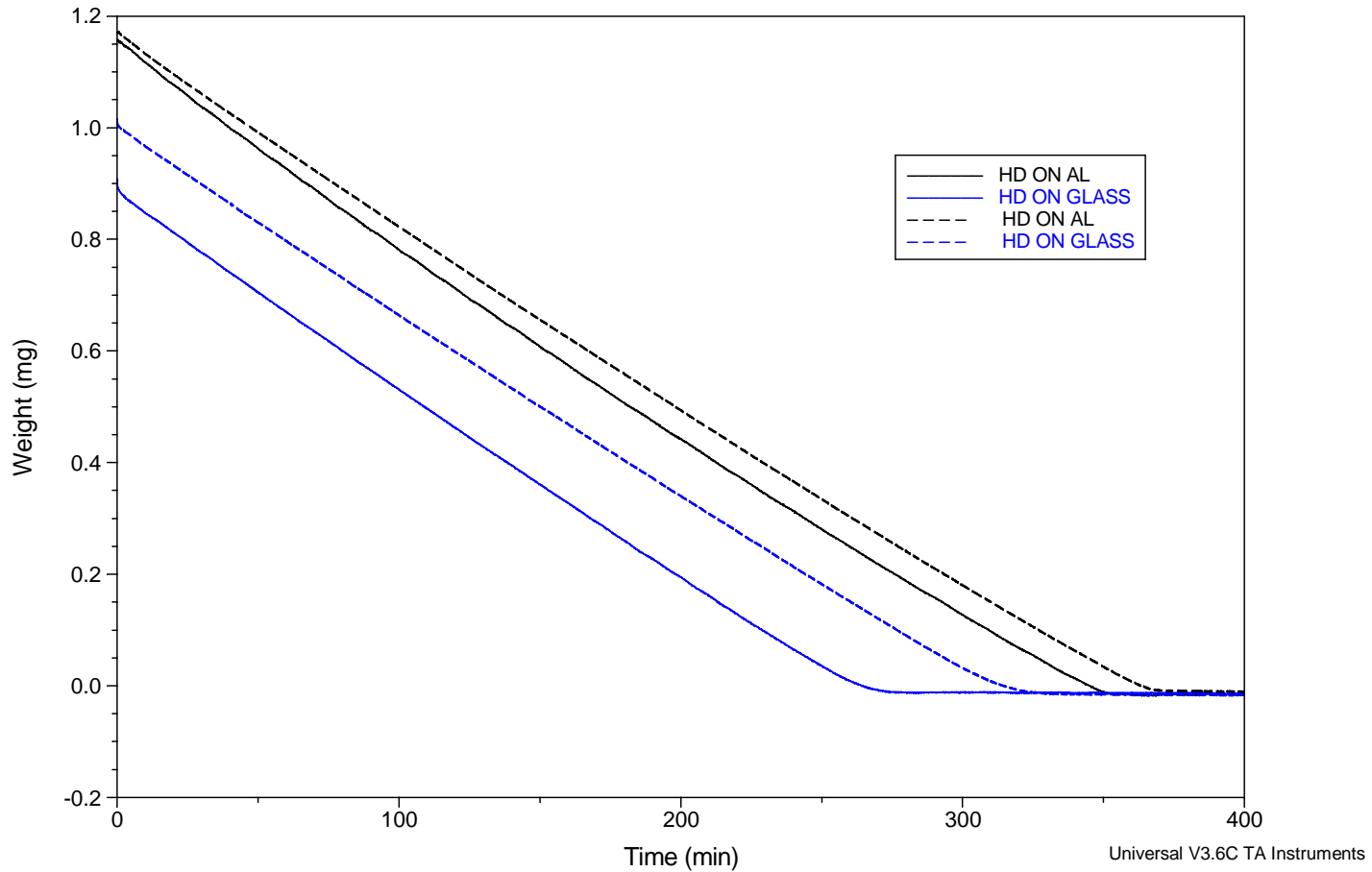

Figure 15. Comparison of HD Evaporation Rate from Glass (window) versus Aluminum: @30 degrees C, 0% Relative Humidity, 100mL/min Flow Rate.

WEIGHT LOSS OF HD DROPLETS ON ALUMINUM DISK  
@30 degrees C, Relative Humidity 0%, Flow Rate 100mL/min

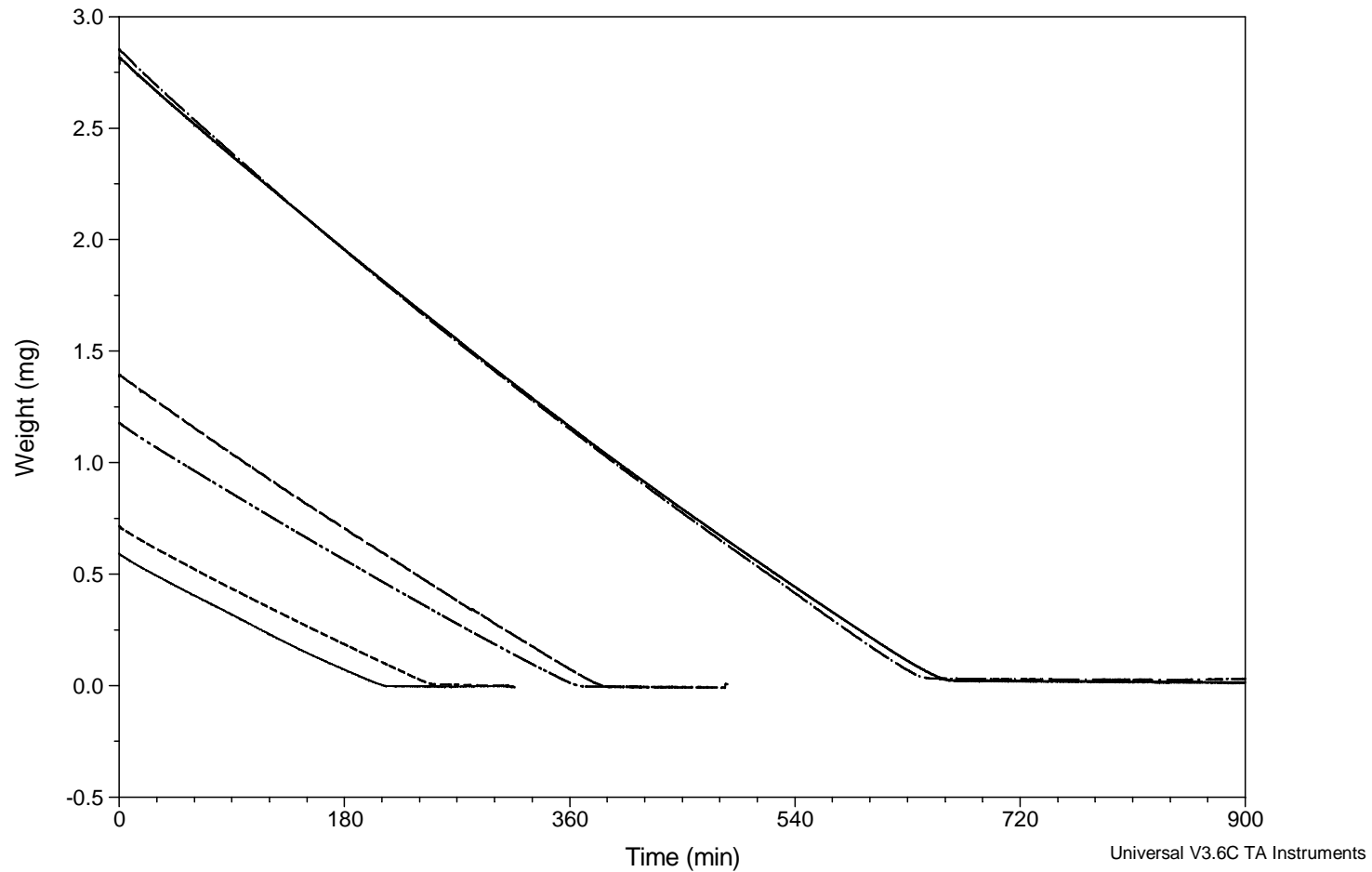

Figure 16. Comparison of HD Evaporation Rate from Aluminum:  
Drop Size Effect  
@30 degrees C, 0% Relative Humidity, 100 mL/min Flow Rate

WEIGHT LOSS OF HD DROPLET ON AL DISK AT VARIOUS TEMPERATURES

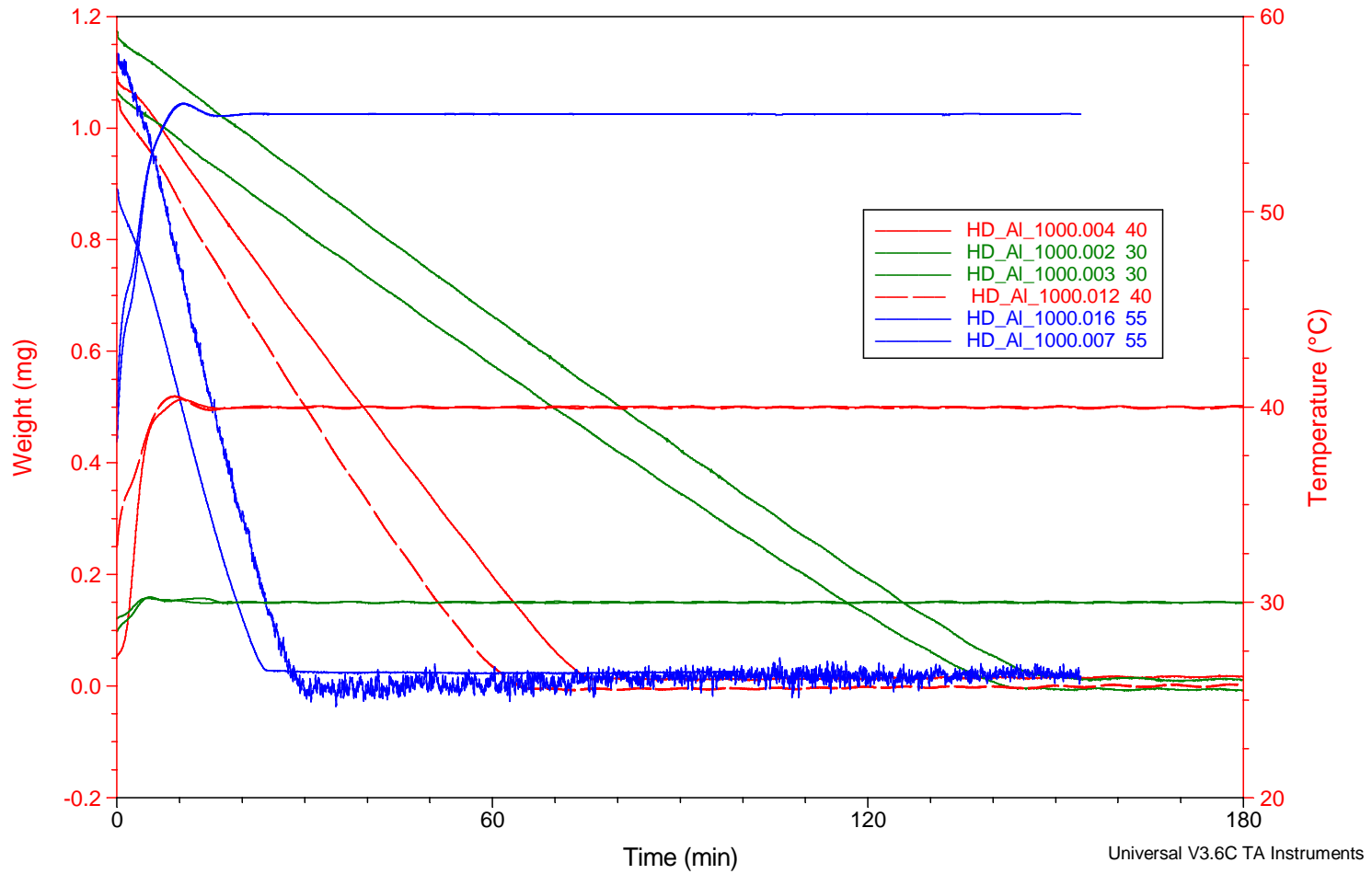

Figure 17. Comparison of HD Evaporation Rate from Aluminum At Various Temperatures: 0% Relative Humidity, 100 mL/min Flow Rate.

WEIGHT LOSS OF HD DROPLETS ON ALUMINUM DISKS AT VARIOUS FLOW RATE  
@15C, RELATIVE HUMIDITY 15.58%

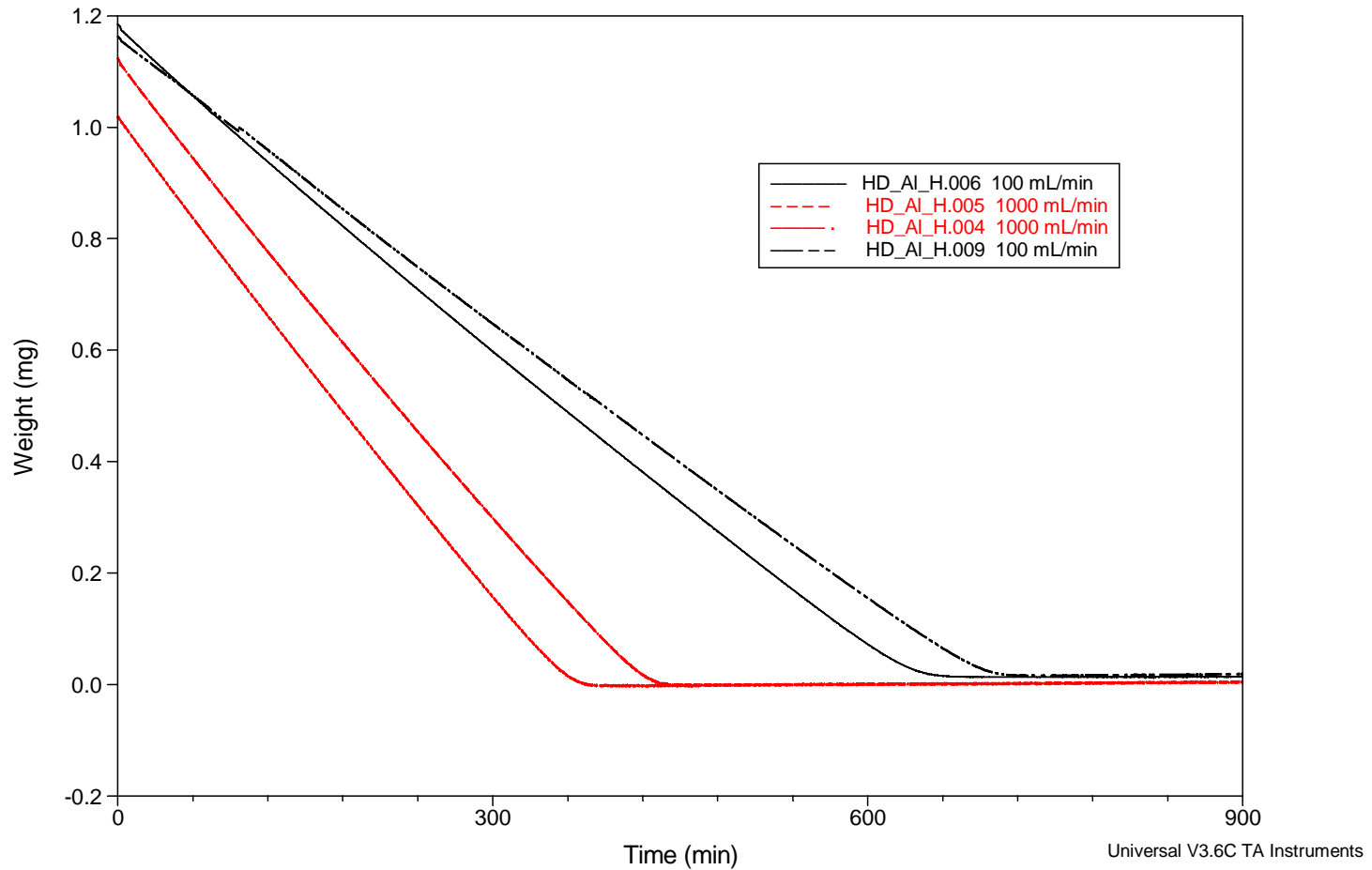

Figure 18. Comparison of HD Evaporation Rate from Aluminum  
at Various Flow Rates:  
@15 degrees C, 15.58% Relative Humidity

WEIGHT LOSS OF HD DROPLETS ON ALUMINUM DISKS AT VARIOUS FLOW RATES  
@40C, RELATIVE HUMIDITY 21.48%

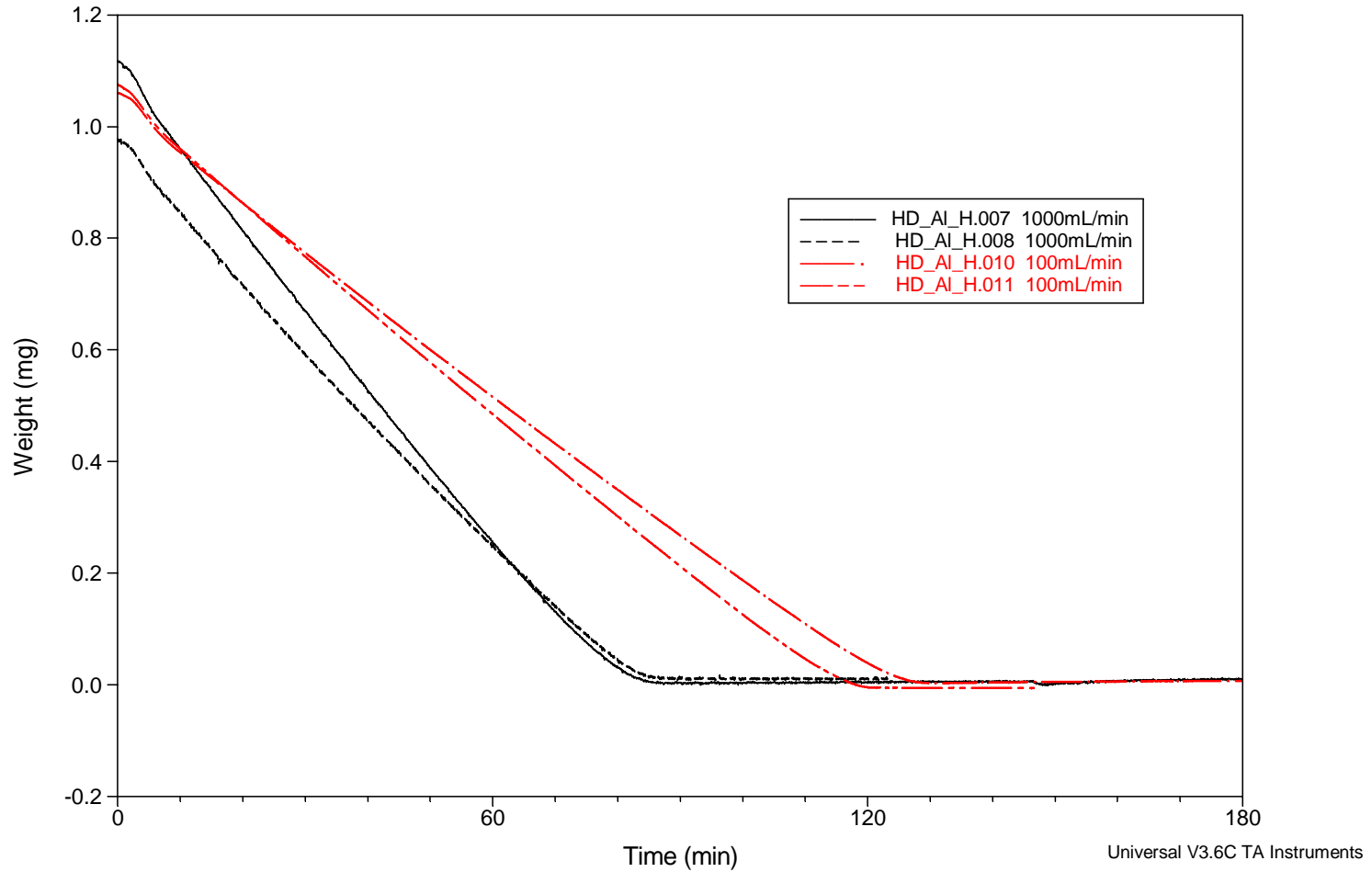

Figure 19. Comparison of HD Evaporation Rate from Aluminum At Various Flow Rates:  
@40 degrees C, 21.5% Relative Humidity

WEIGHT LOSS OF HD DROPLETS ON DIFFERENT SURFACES  
@30 degrees C, Relative Humidity 0%, Flow Rate 100mL/min

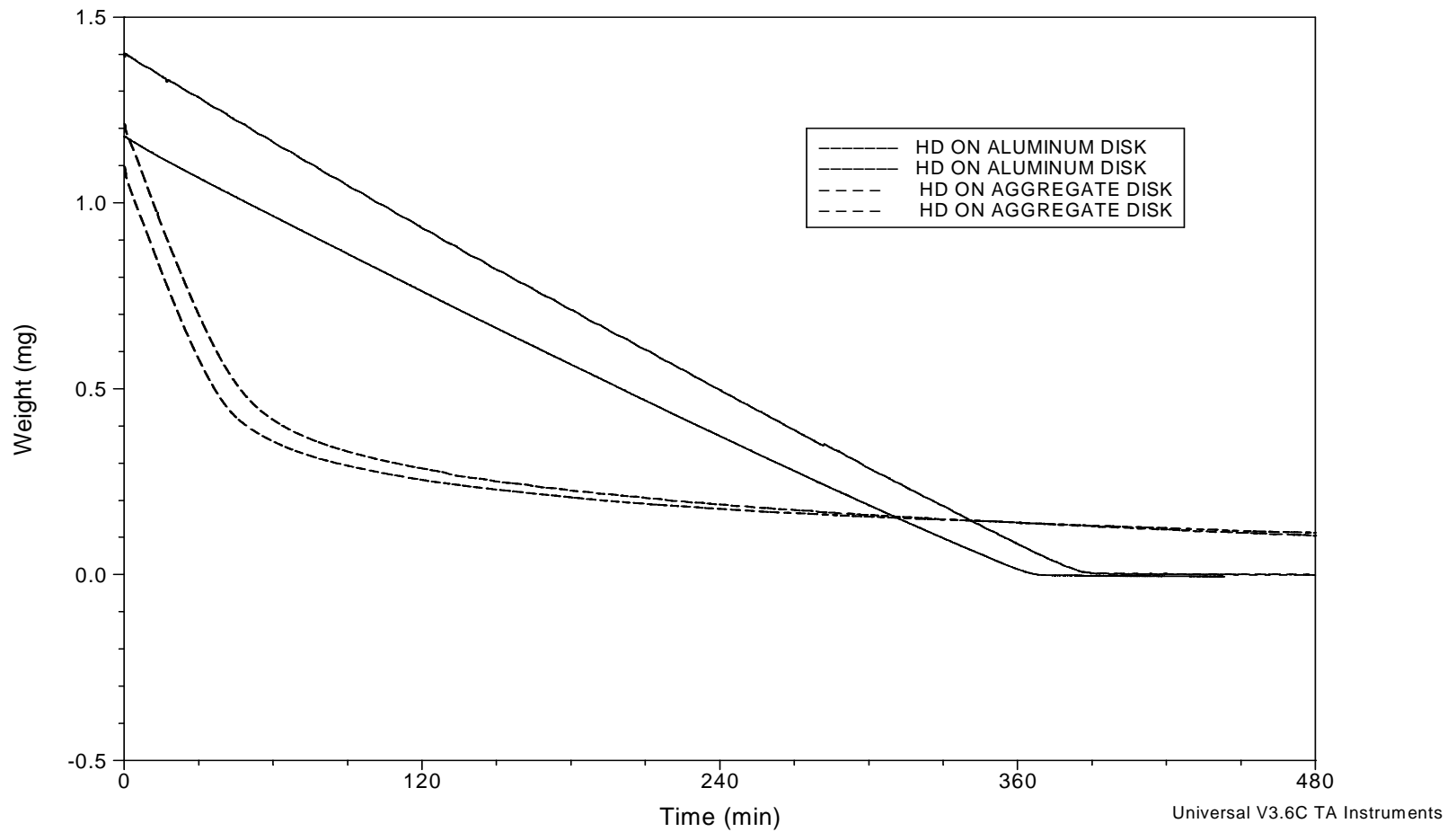

Figure 20. Comparison of HD Evaporation Rate from Aluminum versus Aggregate:  
@30 degrees C, 0% Relative Humidity, 100mL/min Flow Rate.

WEIGHT LOSS OF HD DROPLETS ON AGGREGATE  
@30 degrees C, Relative Humidity 0%, Flow Rate 100mL/min

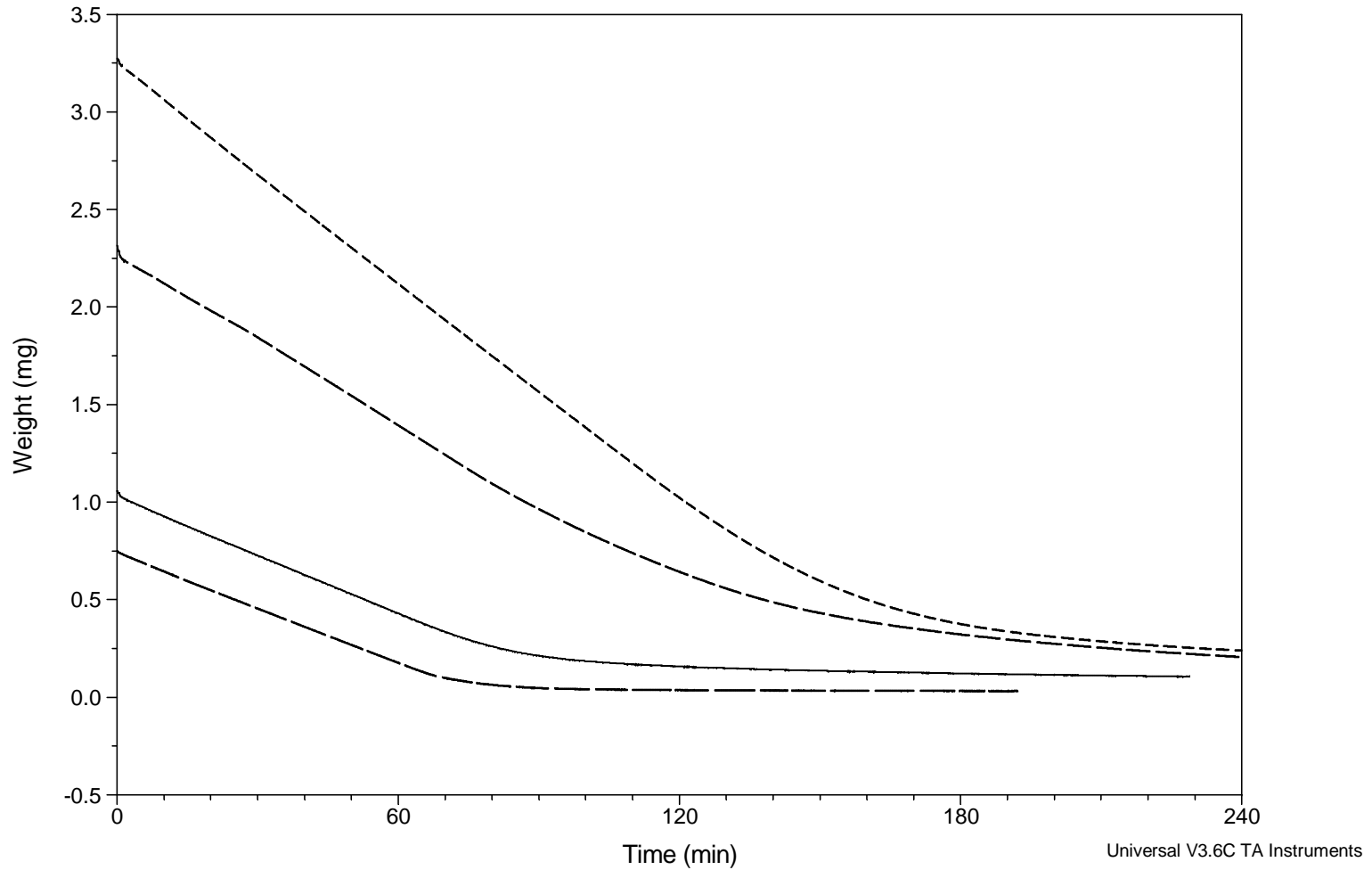

Figure 21. Comparison of HD Evaporation Rate from Aggregate:  
Effect of Drop Size  
@30 degrees C, 0% Relative Humidity, 100mL/min Flow Rate

WEIGHT LOSS OF HD DROPLET ON AGGREGATE DISK AS A FUNCTION OF TIME

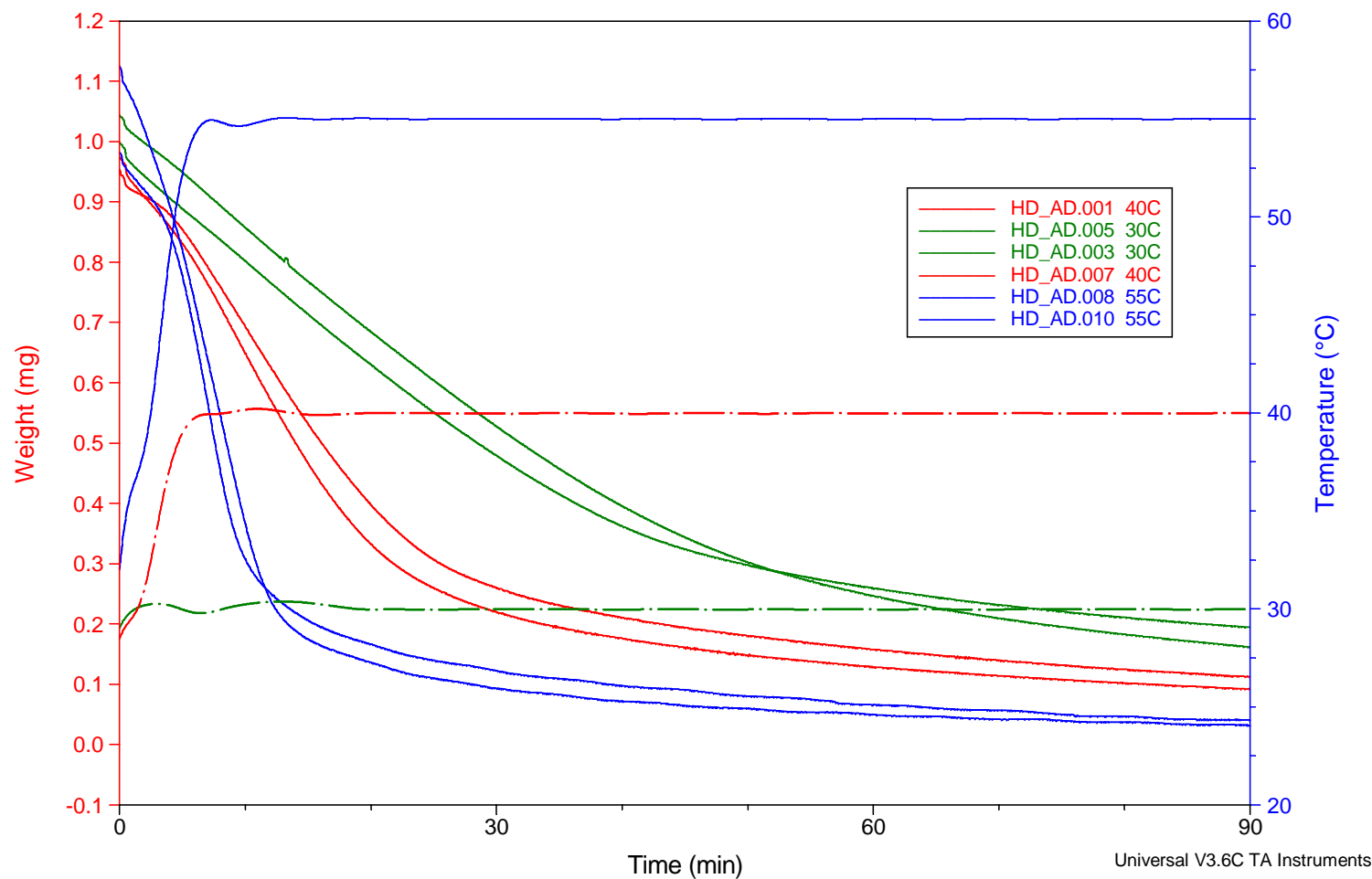

Figure 22. Comparison of HD Evaporation Rate from Aggregate  
At Various Temperatures:  
0% Relative Humidity, 100mL/min Flow Rate.

Weight Loss of HD Droplet on Aggregate Disk as a Function of Time  
@30 C, 0% Relative Humidity, Drop Size 0.5uL

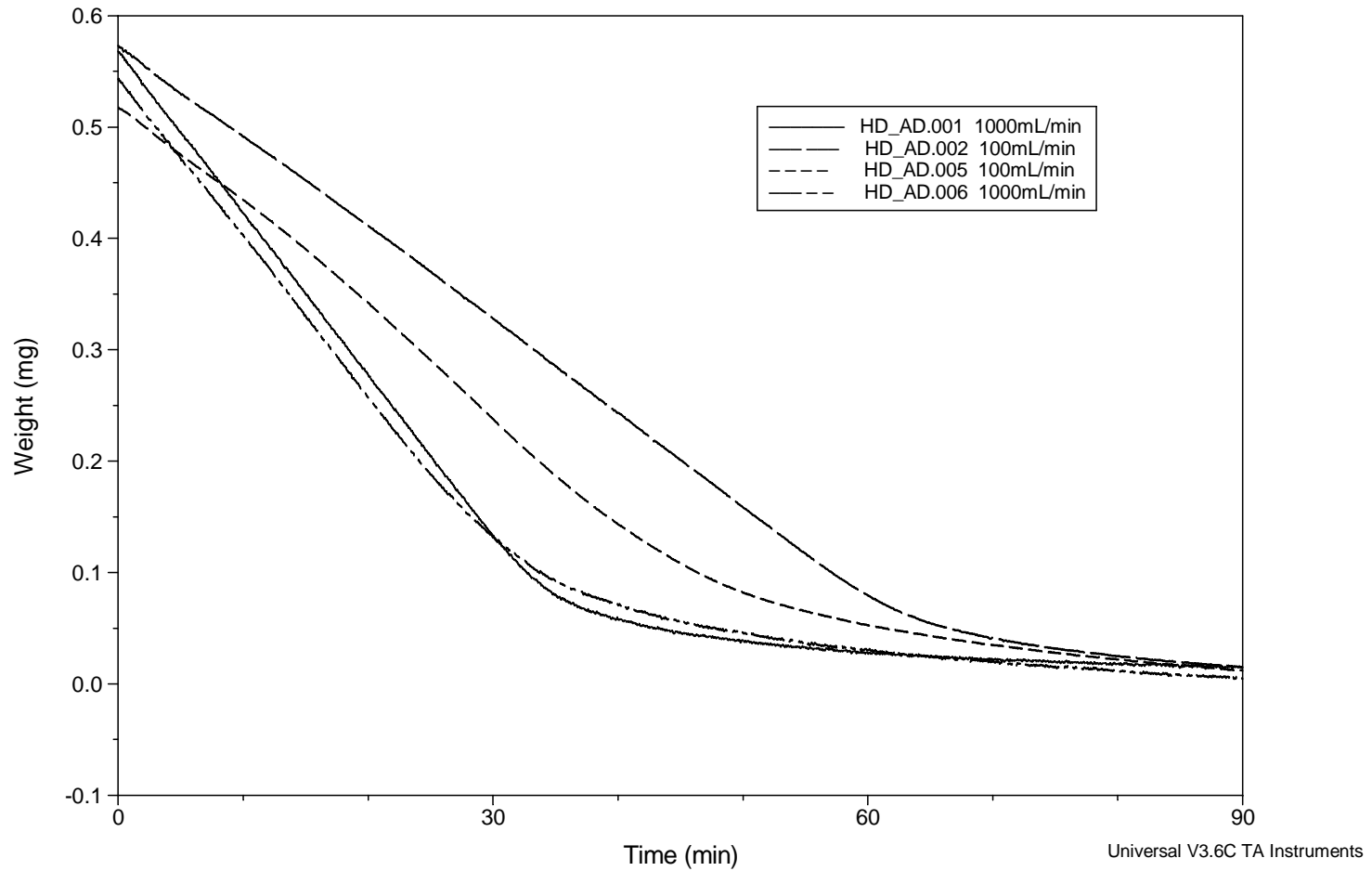

Figure 23. Comparison of HD Evaporation Rate from Aggregate  
at Various Flow Rates:  
@30 degrees C, 0% Relative Humidity

# Summary Table

Fig #	Surface	Experimental Conditions				Comparison
		Temp (C)	Rel Humidity (%)	Flow Rate (mL/min)	Drop size (uL)	
7	Glass, cover	30	0	100	0.91	Cleaned vs Uncleaned
8	Glass, window	40	0	V	0.91	Various Flow Rates
9	Glass, window	V	0	100	0.91	Various Temp
10	Glass, window	30	0	100	V	Various Drop Sizes
11	Glass, window	40	V	500	0.91	Relative Humidity
12	Glass, TNO	V	0	1000	0.91	Various Temp
13	Glass	30	0	100	0.91	Surface
14	Glass, TNO	35	0	1000	V	Various Drop Sizes
15	Glass & Al	30	0	100	1	Surface
16	Aluminum	30	0	100	V	Various Drop Sizes
17	Aluminum	V	0	100	1	Various Temp
18	Aluminum	15	15.6	V	1	Various Flow Rates
19	Aluminum	40	21.5	V	1	Various Flow Rates
20	Al & Aggregate	30	0	100	1	Surface
21	Aggregate	30	0	100	V	Various Drop Sizes
22	Aggregate	V	0	100	1	Various Temp
23	Aggregate	30	0	V	0.5	Various Flow Rates

# Summary

A preliminary evaluation indicates;

- Rates apparently follow zero-order, film evaporation on inert, non-porous surfaces (Glass and Aluminum).
- Time to complete evaporation increased systematically with drop-size.
- Flow rate, Temperature influence evaporation rate of HD as expected.
- Humidity has no apparent effect on evaporation rate of HD.
- Nitric acid/hexane cleaning of glass has a small effect on evaporation rate of HD.
- Initial evaporation rate of CWA on Concrete Aggregates was more rapid than that on Aluminum Disks, probably due to the Wetted Surface Area (Spread Factor).

# ACKNOWLEDGEMENTS

The authors wish to acknowledge managerial support by Dr. H. Durst and Dr. J. Savage, ECBC.

BACKUP SLIDES

WEIGHT LOSS OF HD ON GLASS(P)  
@40C, 0% RH, 500mL/MIN FR

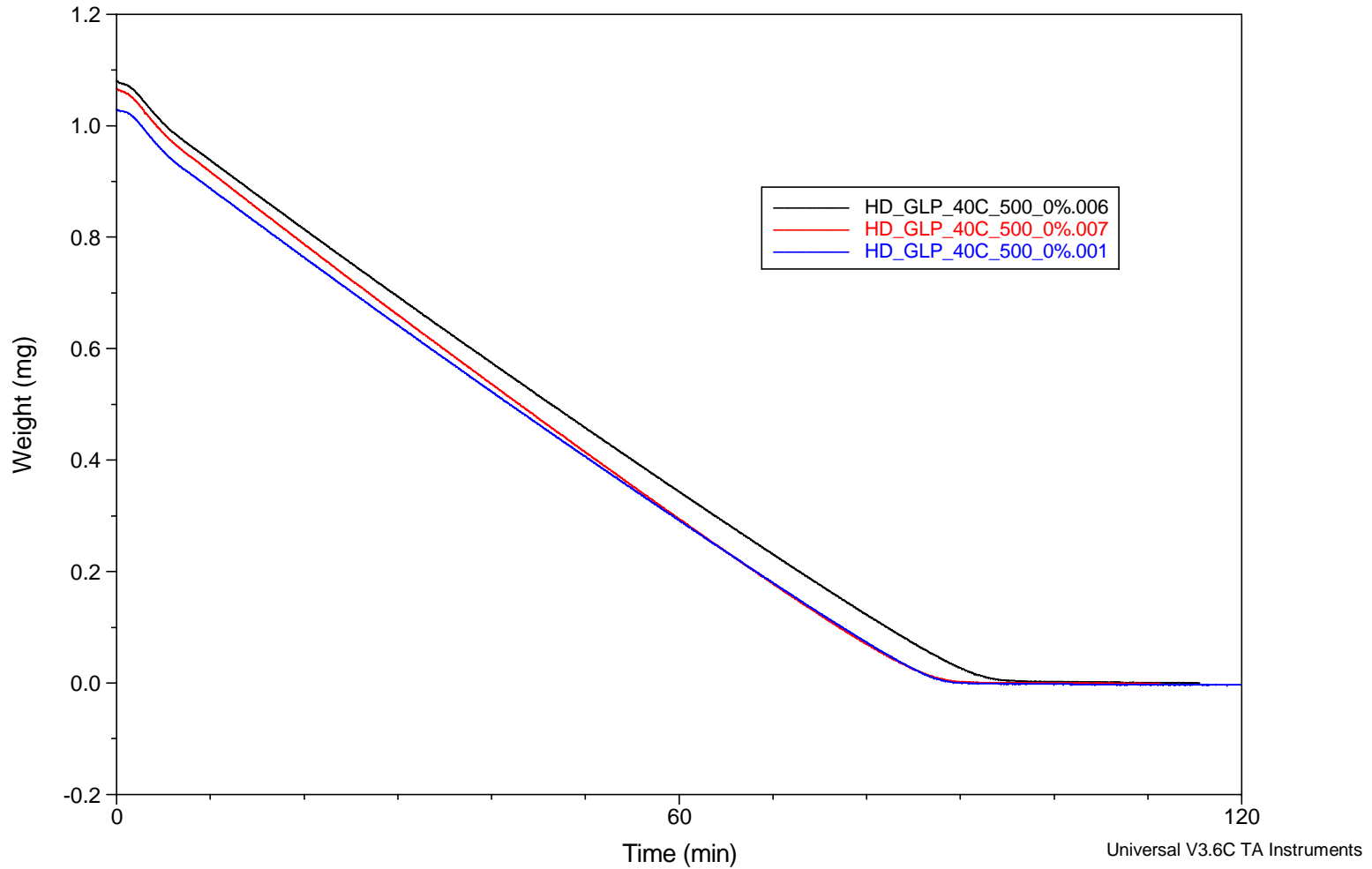

Figure. HD Evaporation Rate from Glass (Window):  
@40 degrees C, 0% Relative Humidity, 500 mL/min Flow Rate

WEIGHT LOSS OF HD ON GLASS(P)  
@40c, 21% RH, 500mL/MIN FR

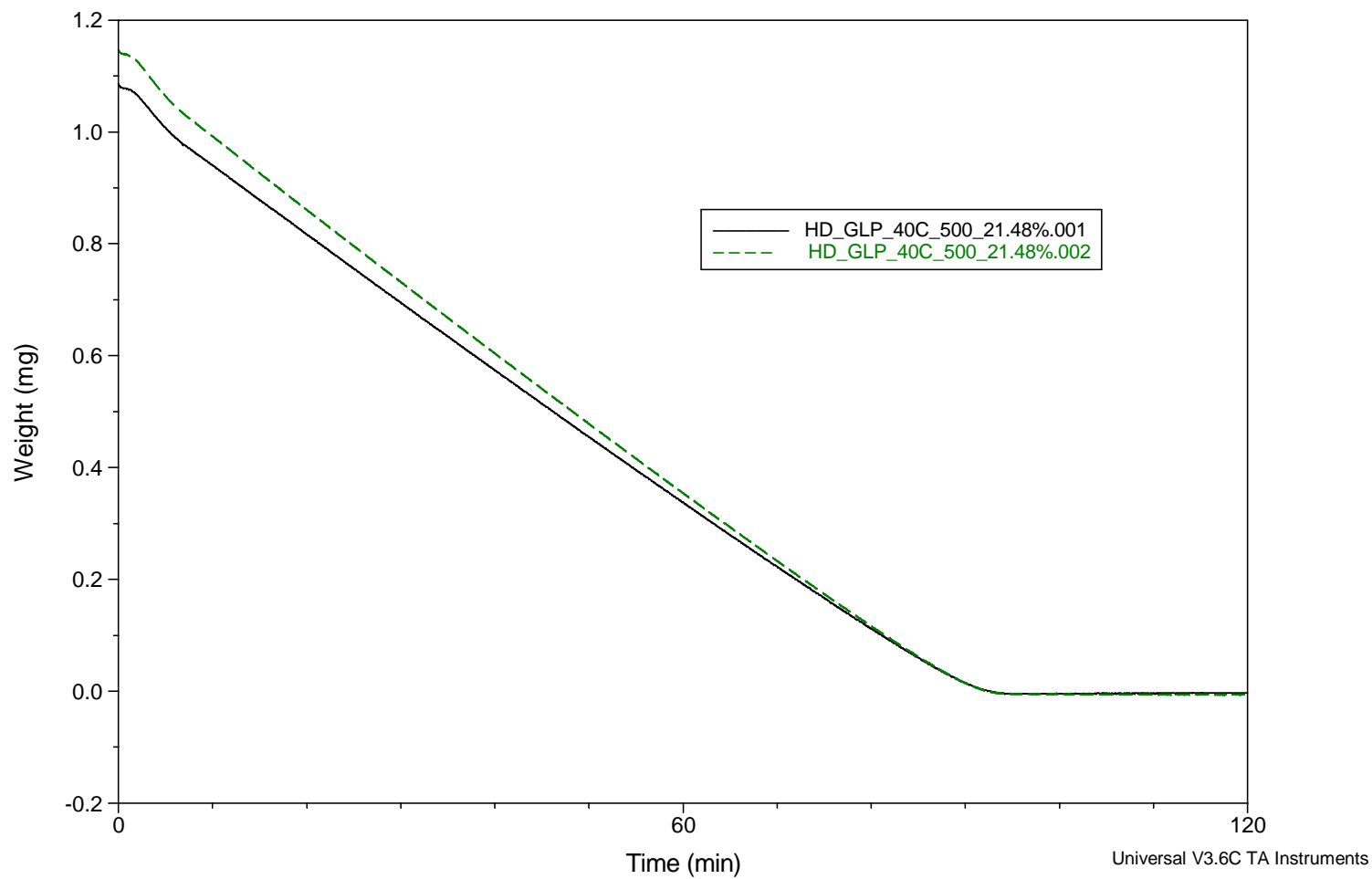

Figure. HD Evaporation Rate from Glass (Window):  
@40 degrees C, 21.5% Relative Humidity, 500 mL/min Flow Rate

WEIGHT LOSS OF HD ON GLASS(P)  
@40C, 45% RH, 500mL/MIN FR

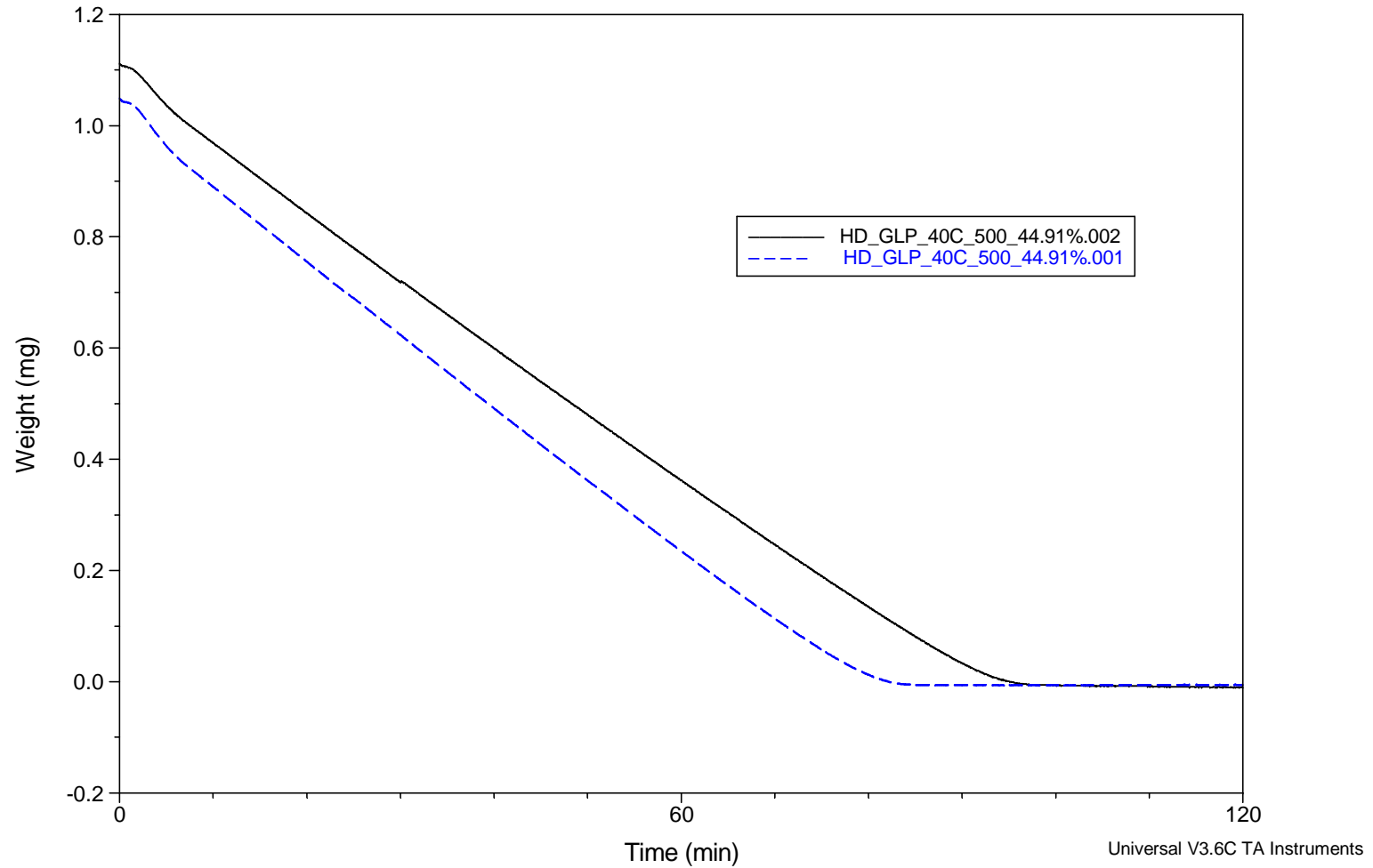
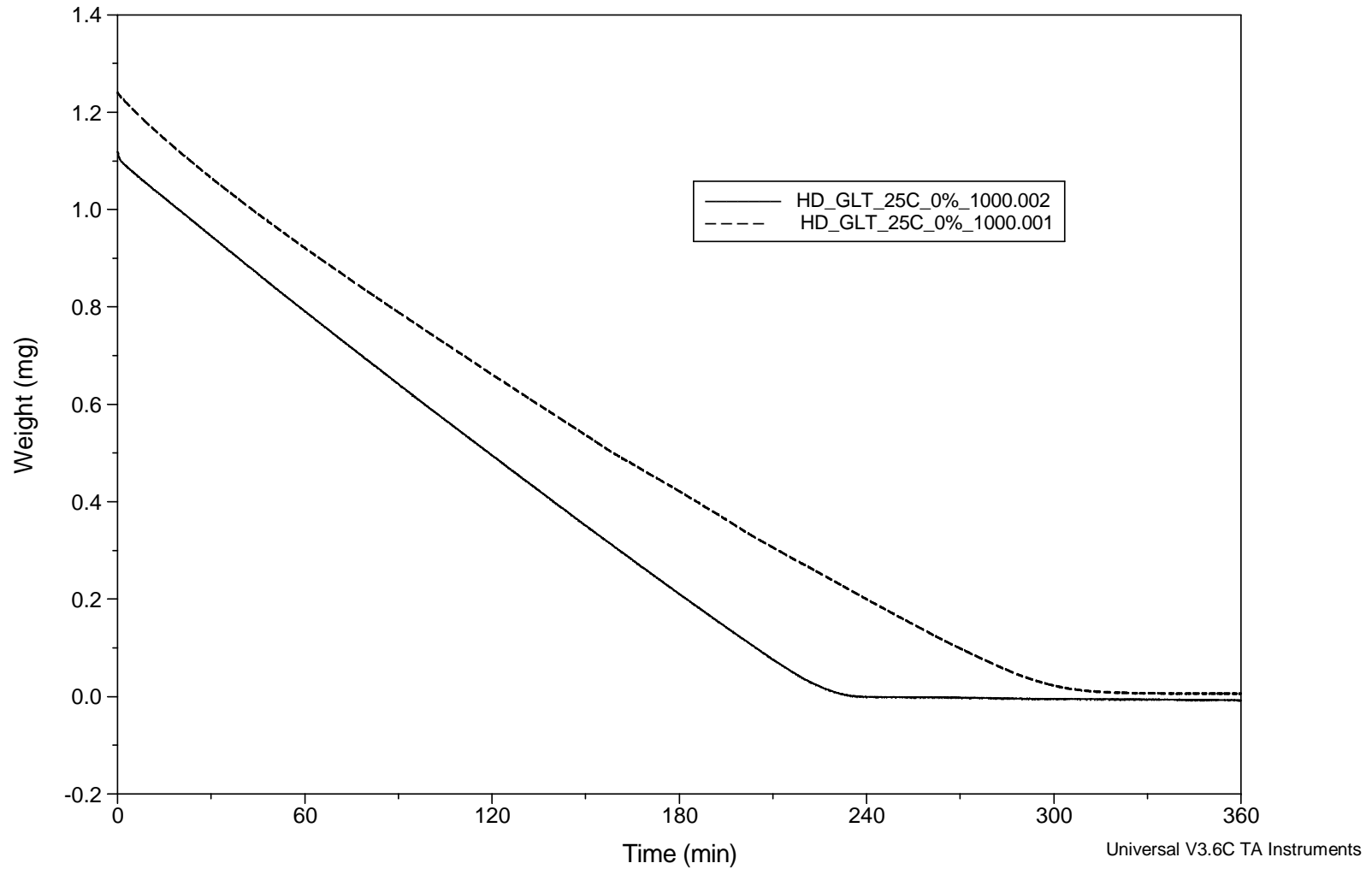

Figure. HD Evaporation Rate from Glass (Window):  
@40 degrees C, 44.9% Relative Humidity, 500 mL/min Flow Rate

2950 HD @25C, 0%, 1000mL/min



**Figure. HD Evaporation Rate from Glass (TNO):**  
@25 degrees C, 0% Relative Humidity, 1000 mL/min Flow Rate

2950 HD ON GLT  
@35C, 0%, 1000mL/min

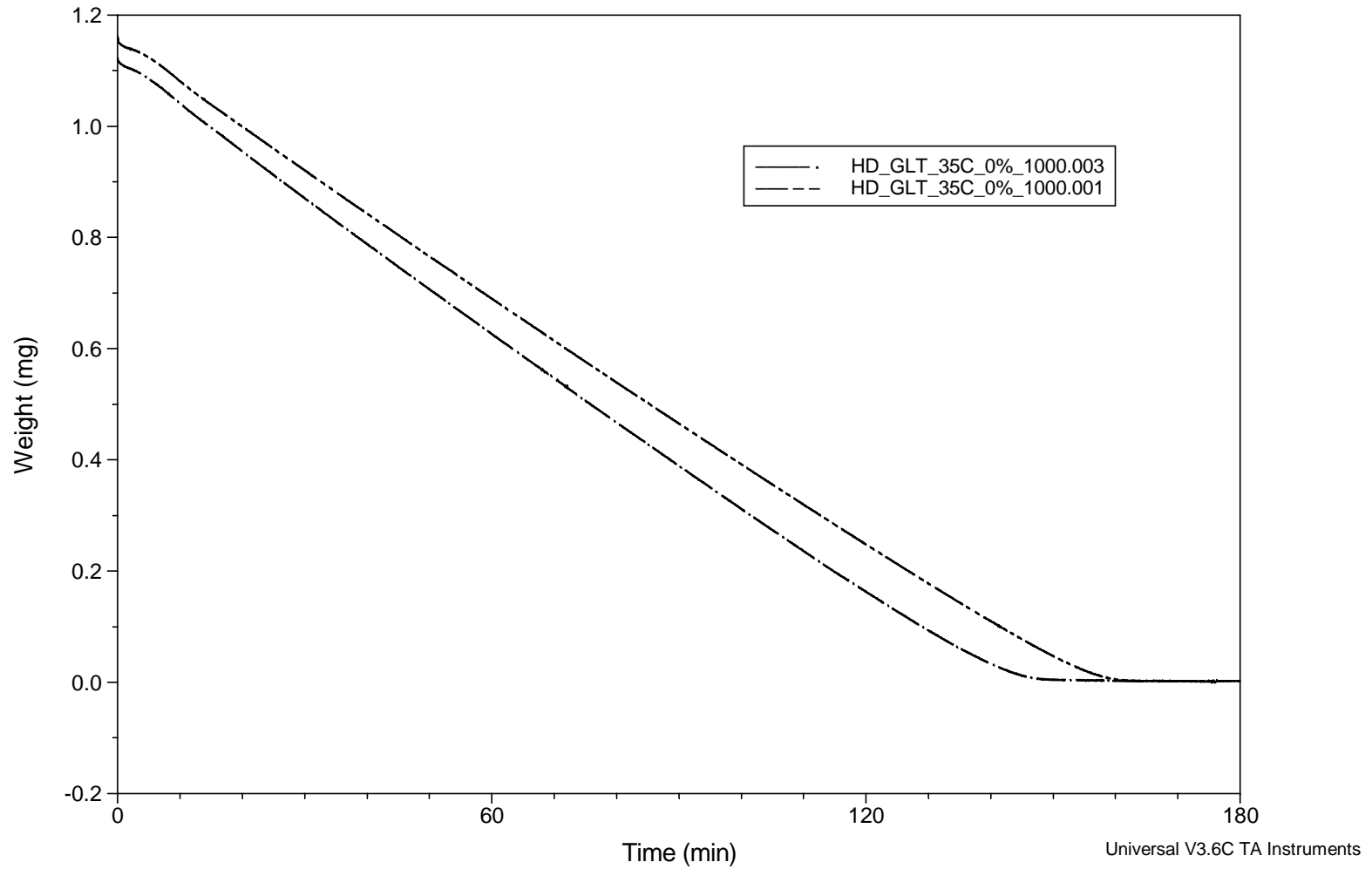

Figure. HD Evaporation Rate from Glass (TNO):  
@35 degrees C, 0% Relative Humidity, 1000 mL/min Flow Rate

2950 HD ON GLT  
@55C, 0%, 1000mL/min

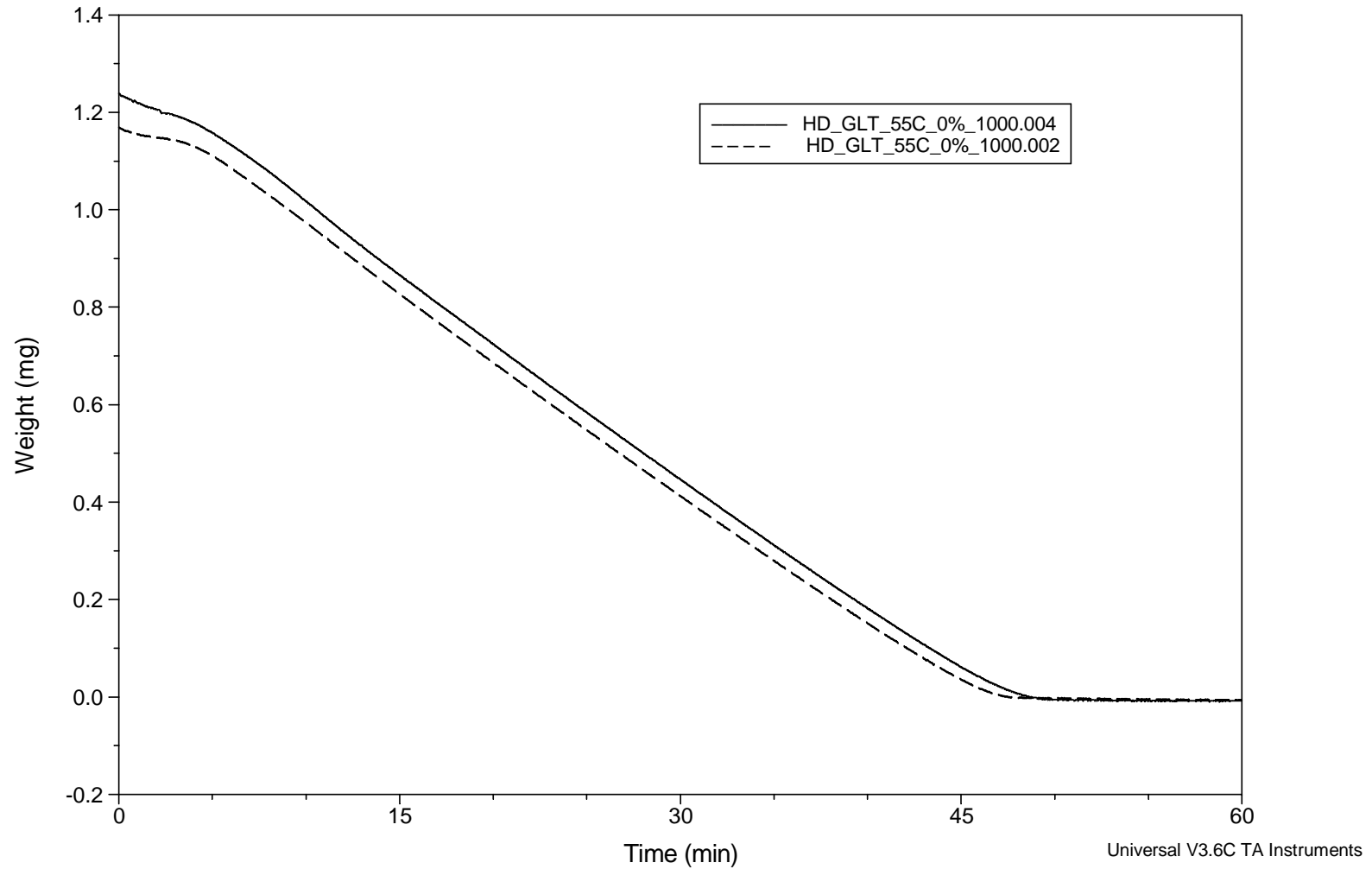

Figure. HD Evaporation Rate from Glass (TNO):  
@55 degrees C, 0% Relative Humidity, 1000 mL/min Flow Rate

HD 2uL  
Isothermal @30 C, RH 0%

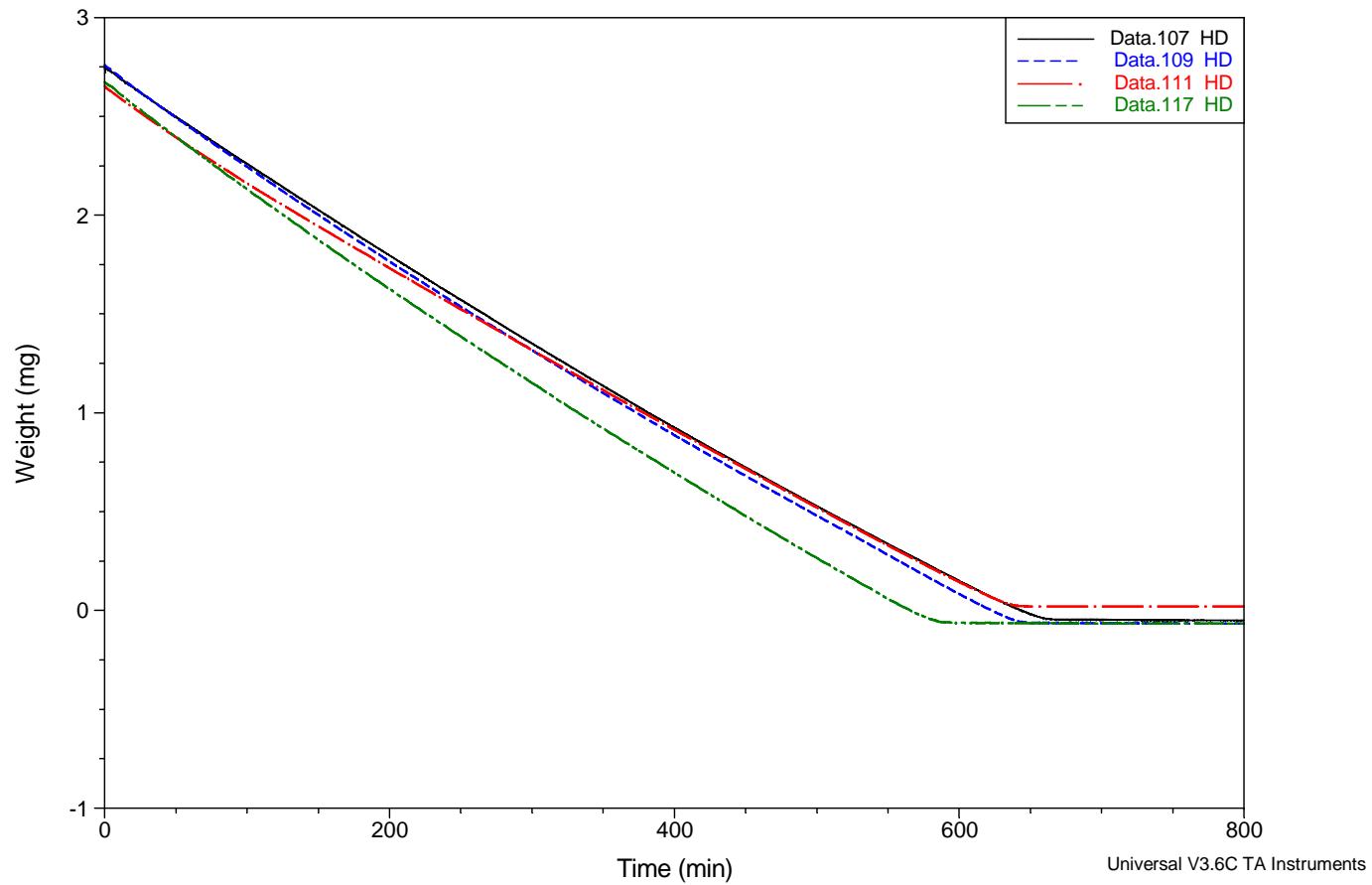

Figure. HD Evaporation Rate from Aluminum:  
@30 degrees C, 0% Relative Humidity, 100 mL/min Flow Rate.

HD 0.5 uL  
Isothermal @30 C, RH 0%

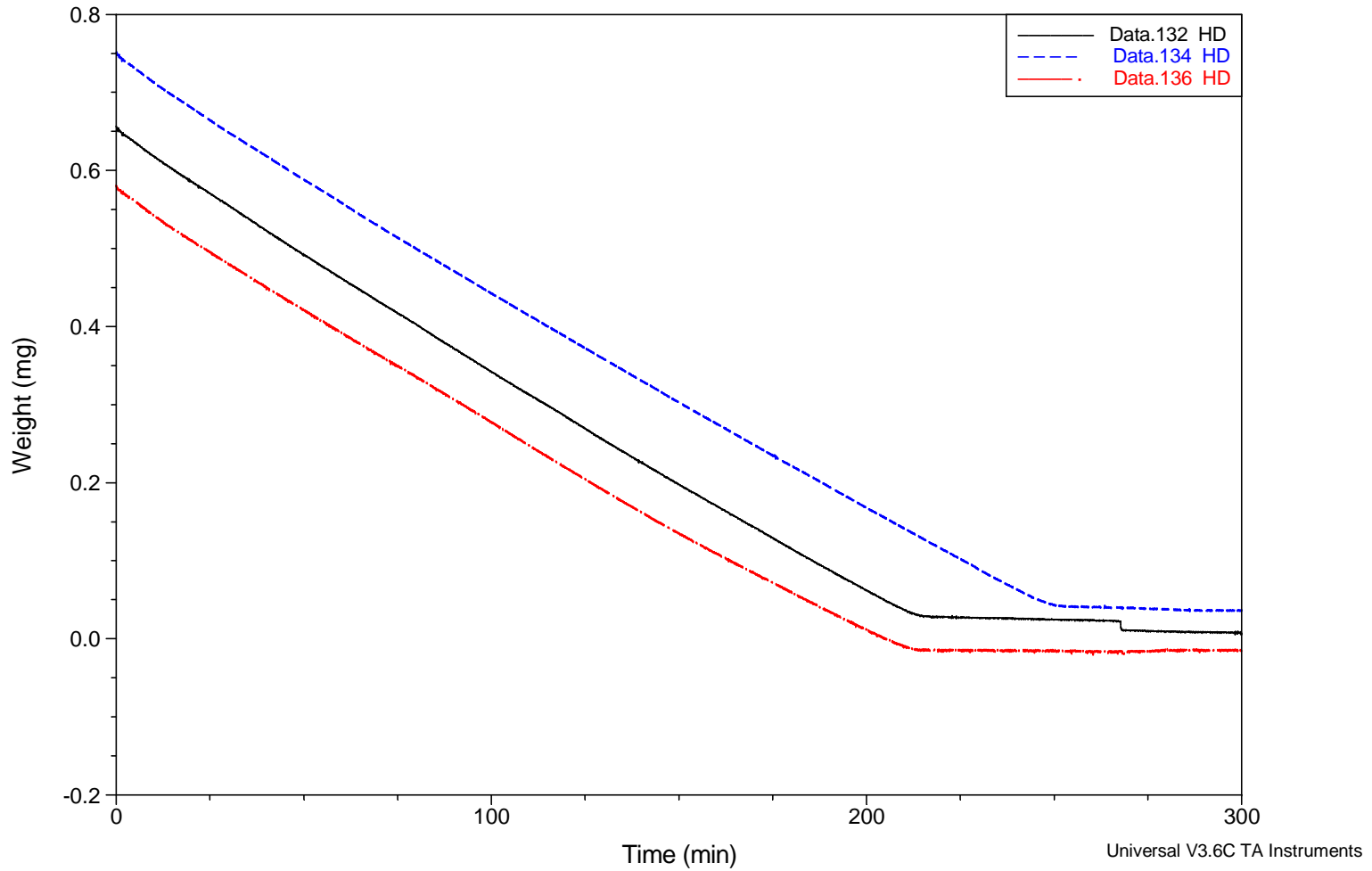
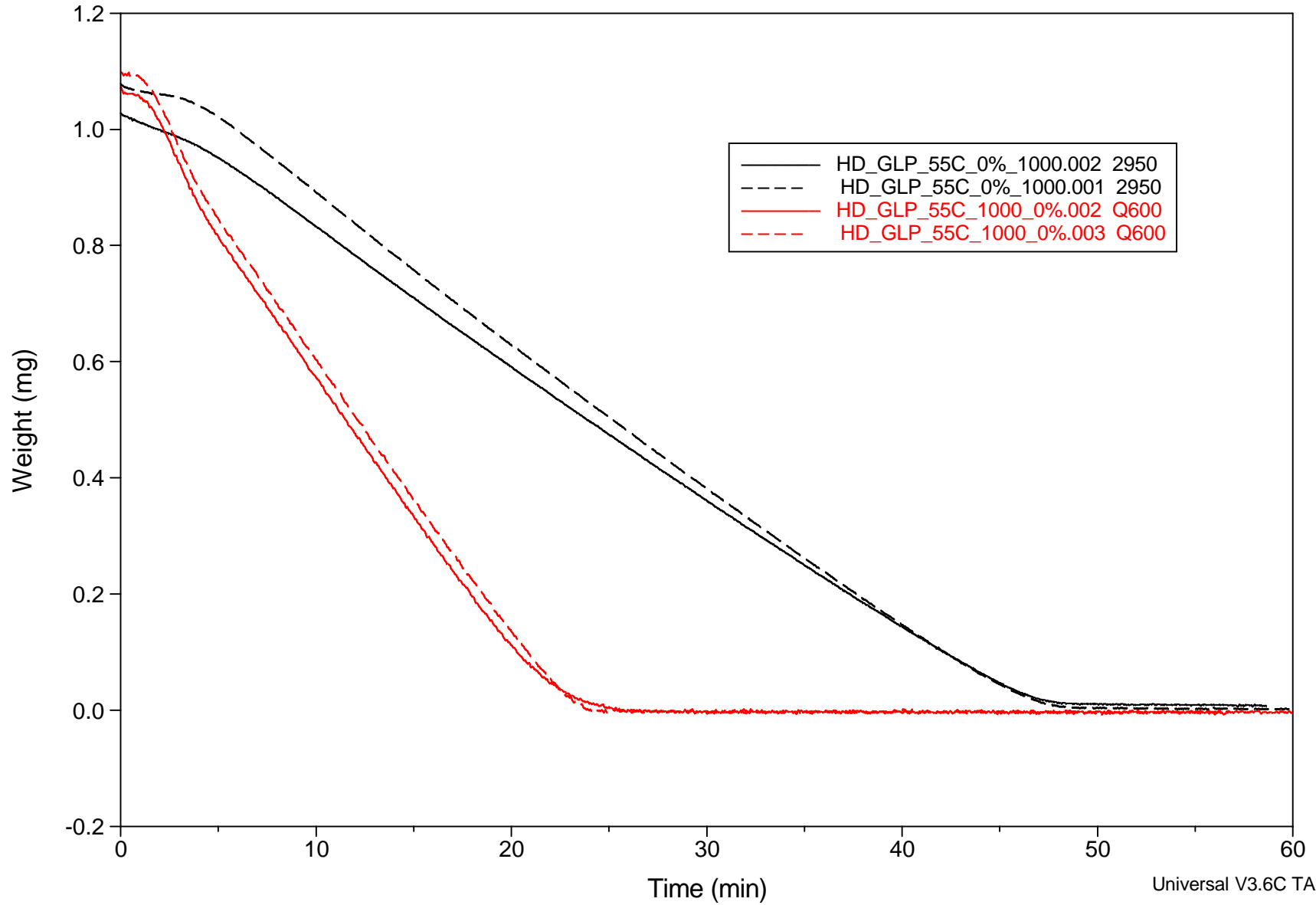

Figure. HD Evaporation Rate from Aluminum:  
@30 degrees C, 0% Relative Humidity, 100 mL/min Flow Rate.

WEIGHT LOSS OF HD ON GLASS(P)  
COMPARISON OF MB HED'S  
@55C, 0%, 1000mL/MIN



WEIGHT LOSS OF GD DROPLETS ON AGGREGATE ROCK VS DISK  
Isothermal @30 Degrees C, Flow Rate 100mL/min, Relative Humidity 0%

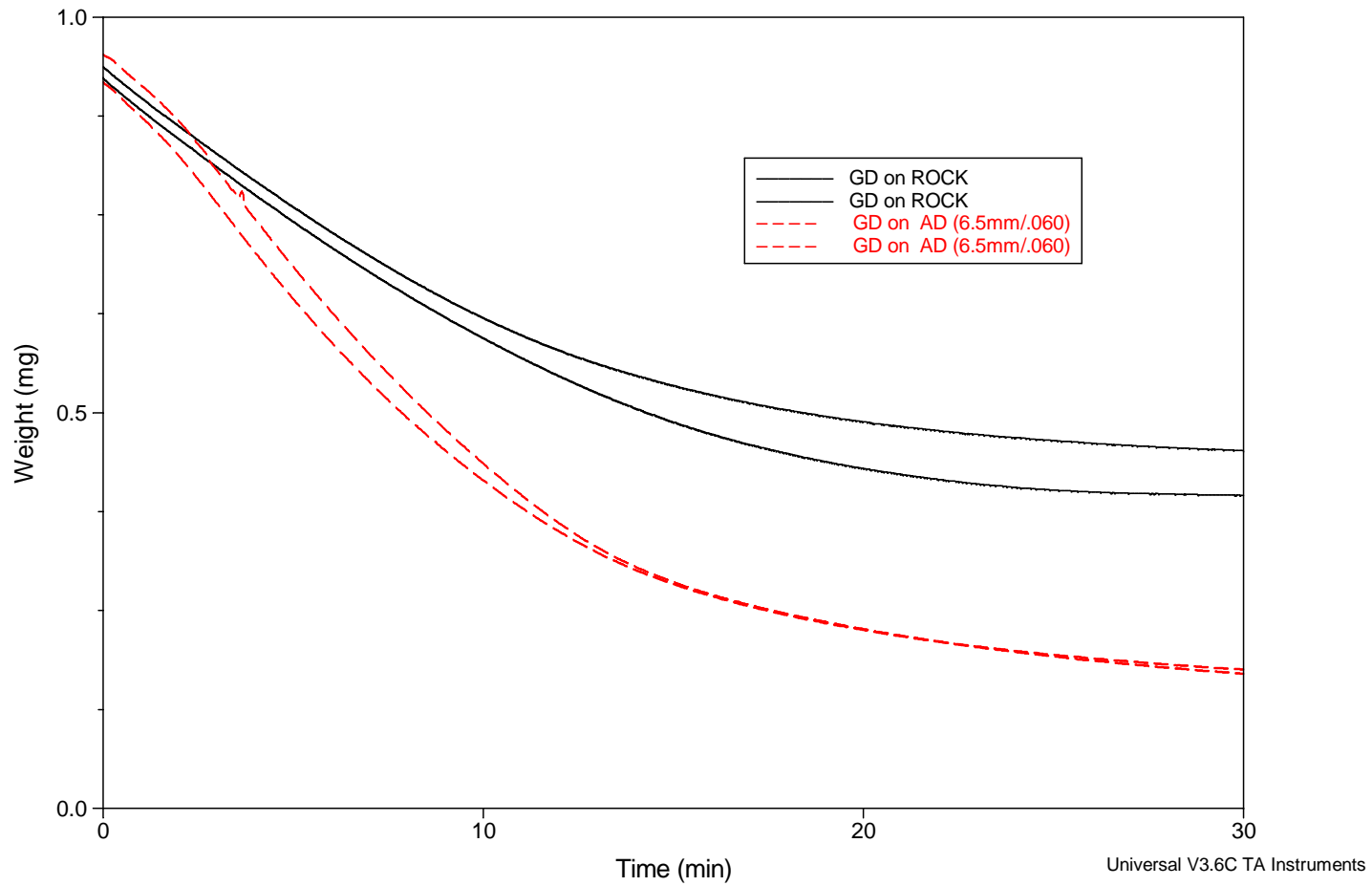

Figure. WEIGHT LOSS OF GD DROPLETS ON AGGREGATE ROCK VS DISK  
Isothermal @ 30 Degrees C, Relative humidity 0%, Flow Rate 100mL/min

WEIGHT LOSS OF GD DROPLETS ON AGGREGATE  
Isothermal @30 degrees C, Flow Rate 100mL/min, Relative Humidity 0%

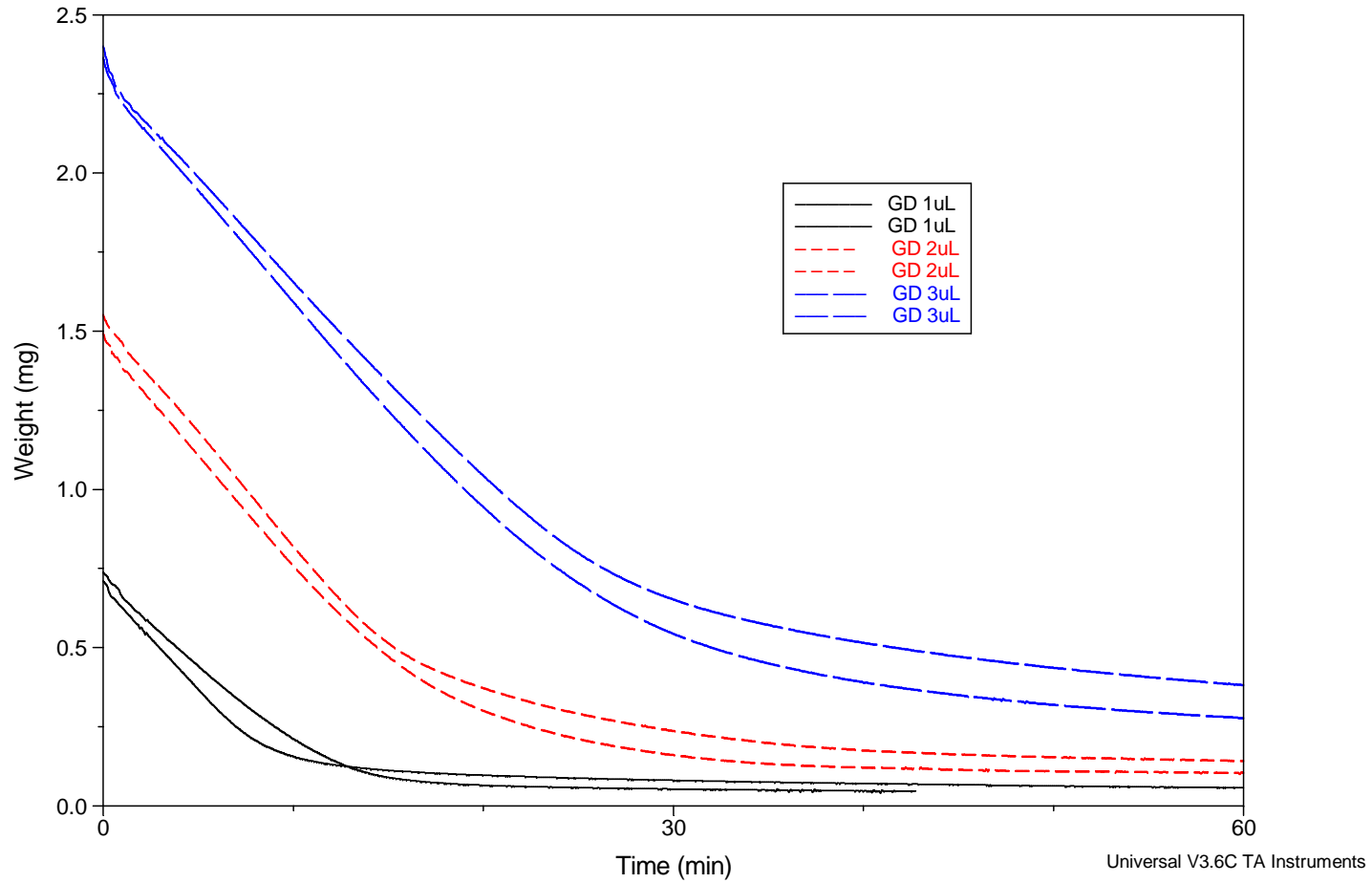

Figure. WEIGHT LOSS OF GD DROPLETS ON AGGREGATE  
Isothermal @ 30 Degrees C, Relative humidity 0%, Flow Rate 100mL/min

Evaporation of GD (2uL Drop) on Different Surfaces  
Isothermal @30C, TGA 2950

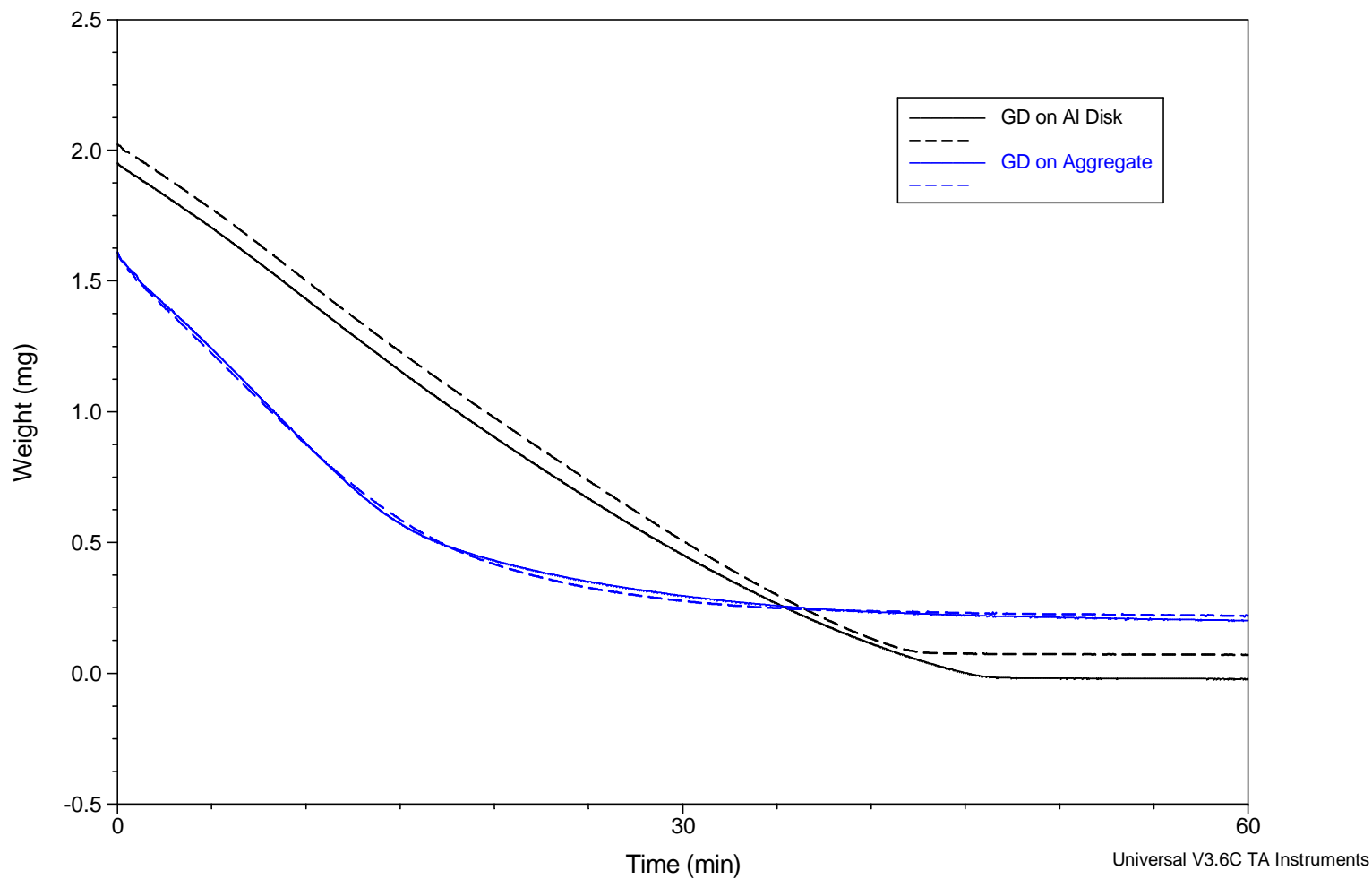

Figure. WEIGHT LOSS OF GD ON ALUMINUM DISKS vs AGGREGATE  
Isothermal @ 30 Degrees C, Relative humidity 0%, Flow Rate 100mL/min

Evaporation of GD on Aluminum Disk  
Isothermal @30C, TGA 2950

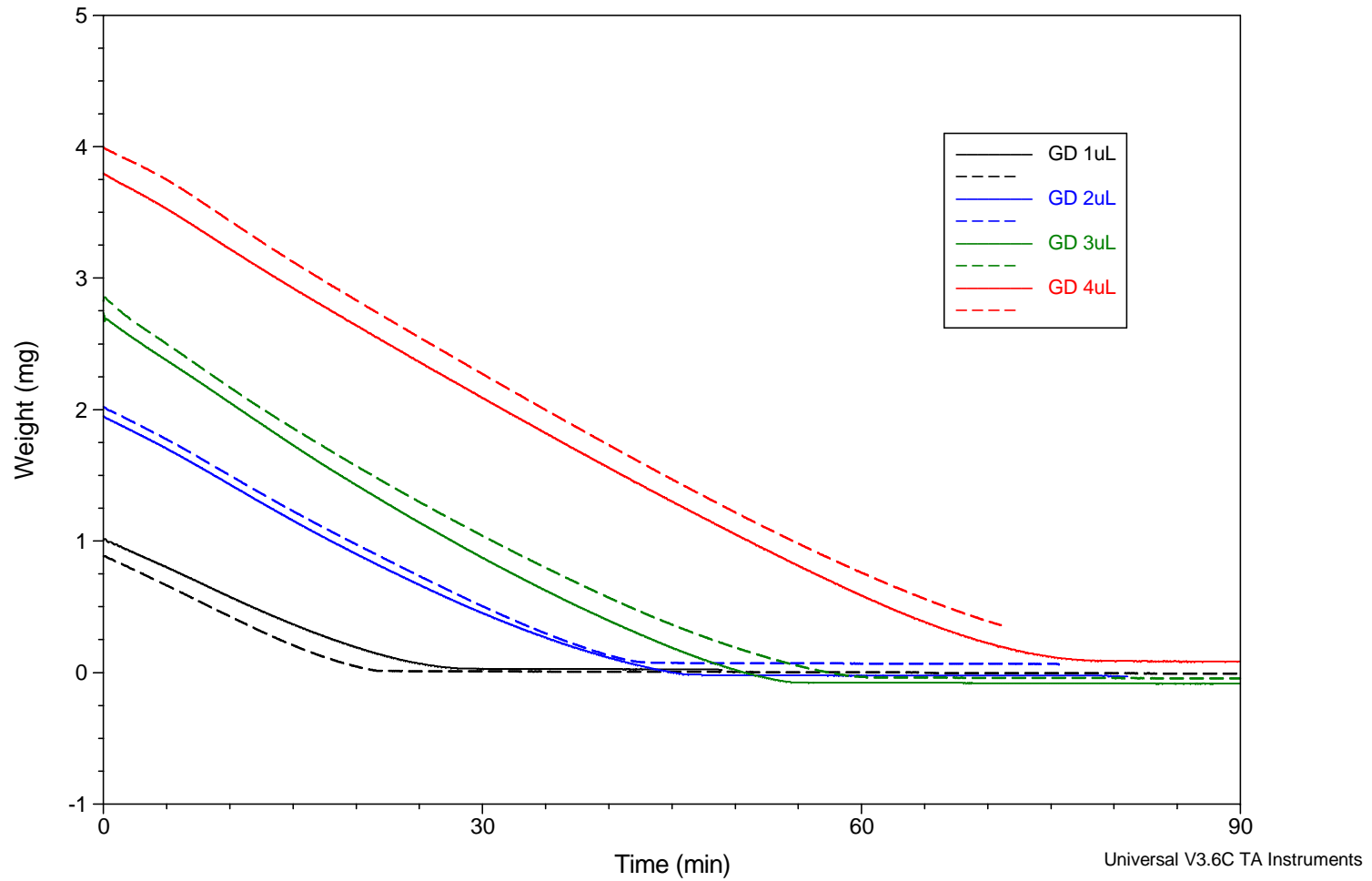

Figure. WEIGHT LOSS OF GD DROPLETS ON ALUMINUM DISKS  
Isothermal @30 degrees C, Relative humidity 0%, Flow Rate 100mL/min

WEIGHT LOSS OF GD DROPLETS ON ALUMINUM DISKS  
Flow Rate 1000mL/min, Relative Humidity 0%

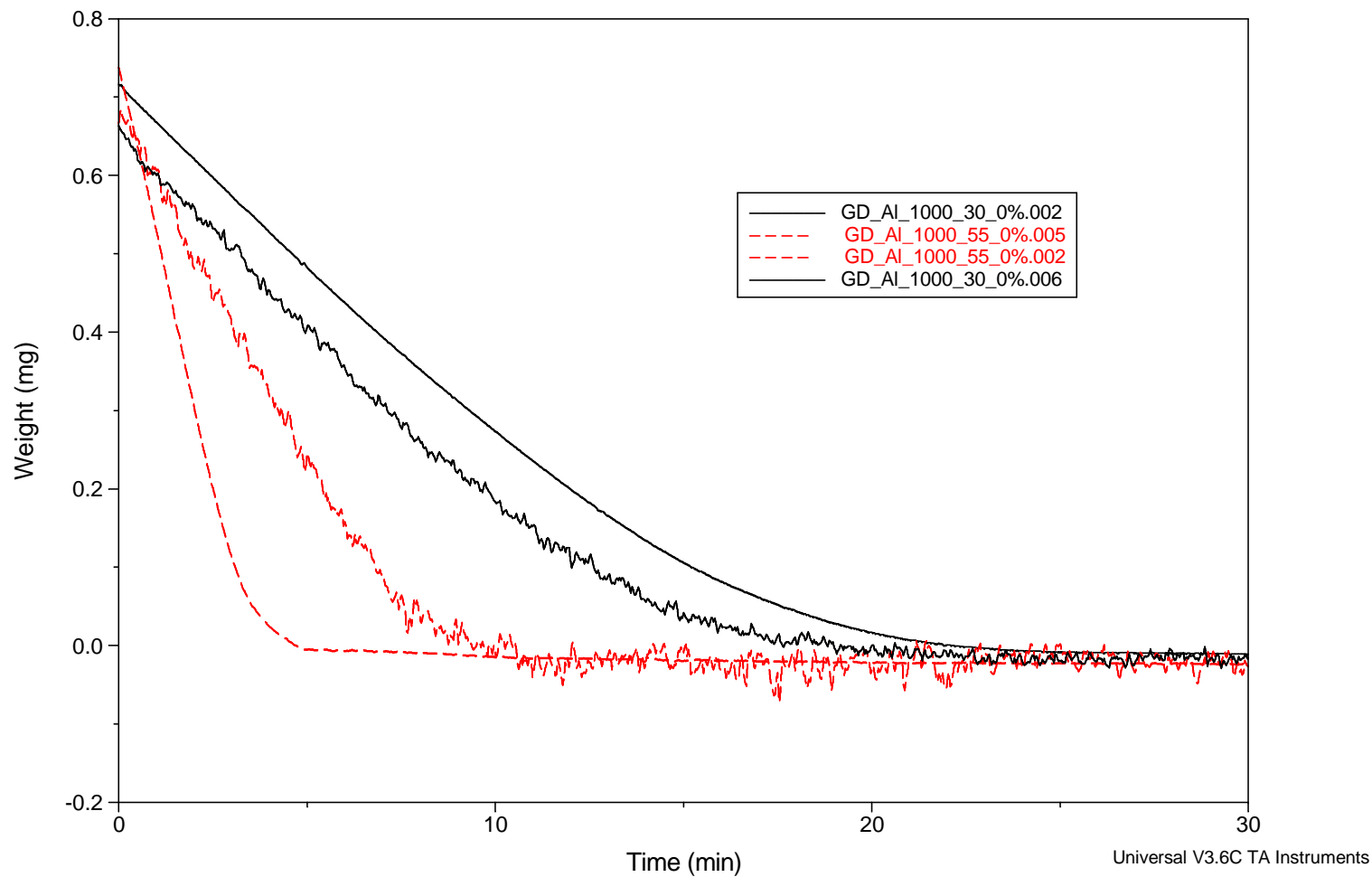

Figure. WEIGHT LOSS OF GD DROPLETS ON ALUMINUM DISKS  
Relative humidity 0%, Flow Rate 1000mL/min

WEIGHT LOSS OF GD DROPLETS ON ALUMINUM DISKS  
Isothermal @30 Degrees C, Relative Humidity 0%

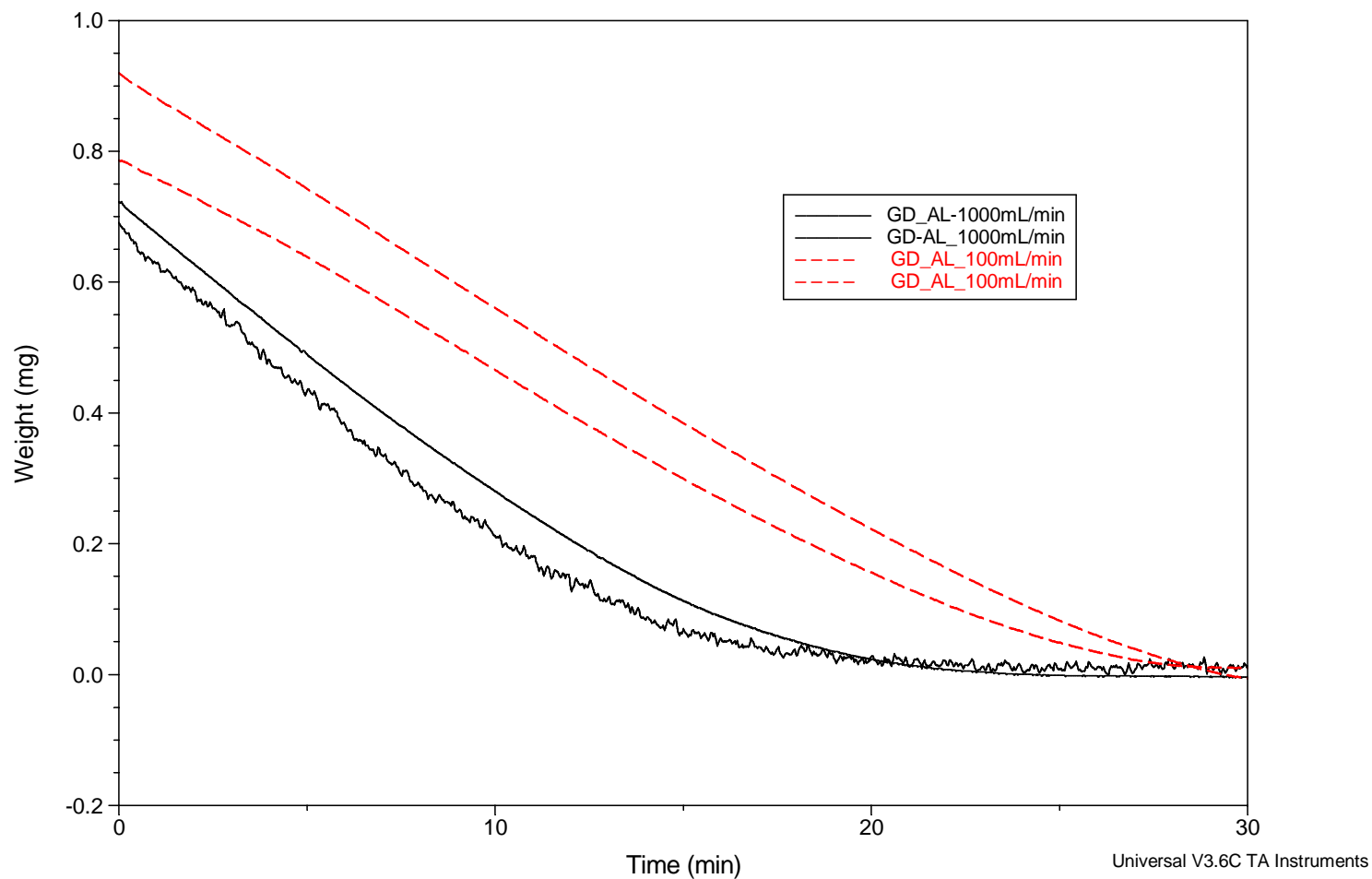

Figure. WEIGHT LOSS OF GD DROPLETS ON ALUMINUM DISKS  
Isothermal @ 30 Degrees C, Relative humidity 0%

Evaporation of GD (2uL Drop) on Different Surfaces  
Isothermal @30C, TGA 2950

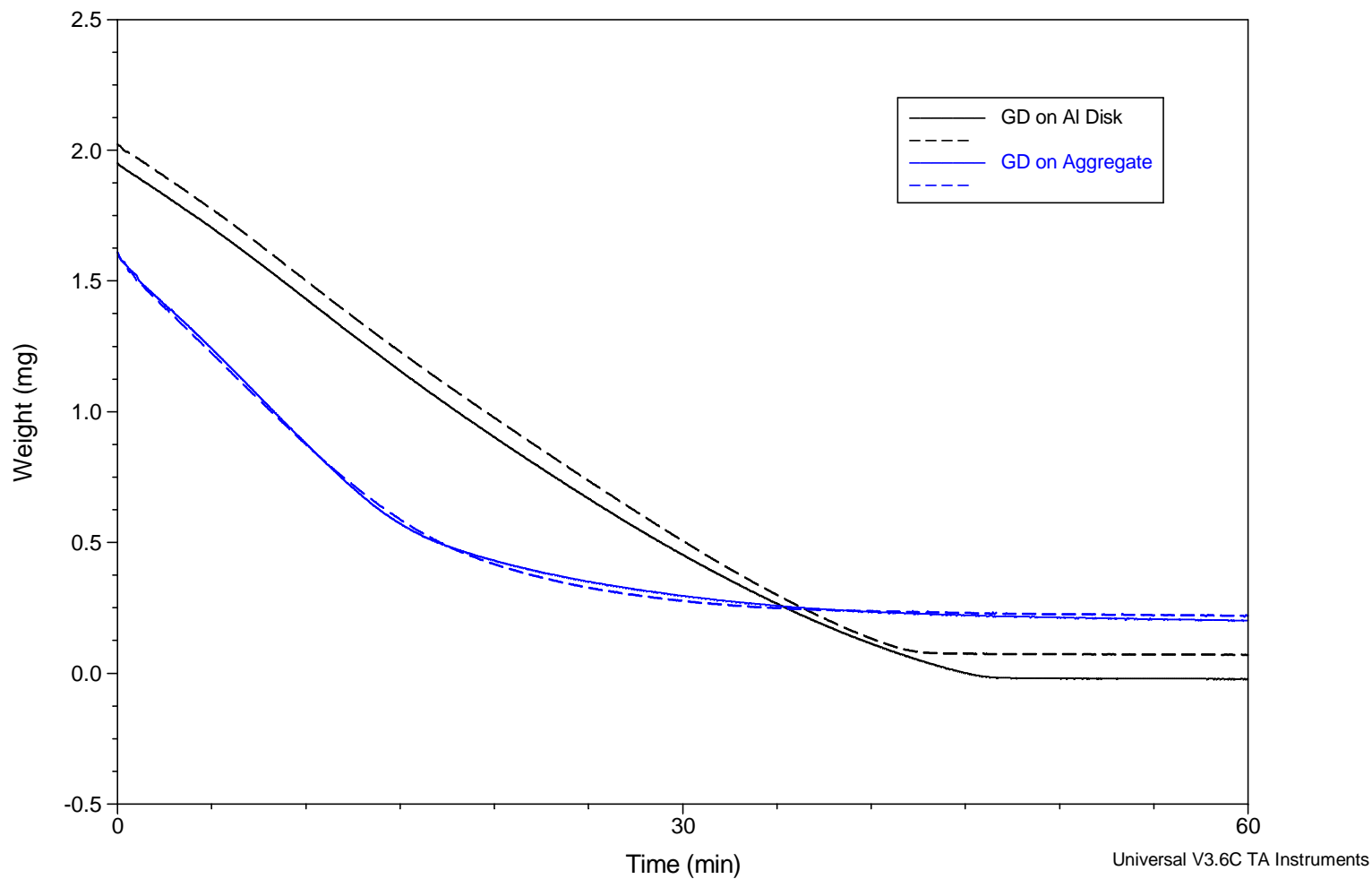
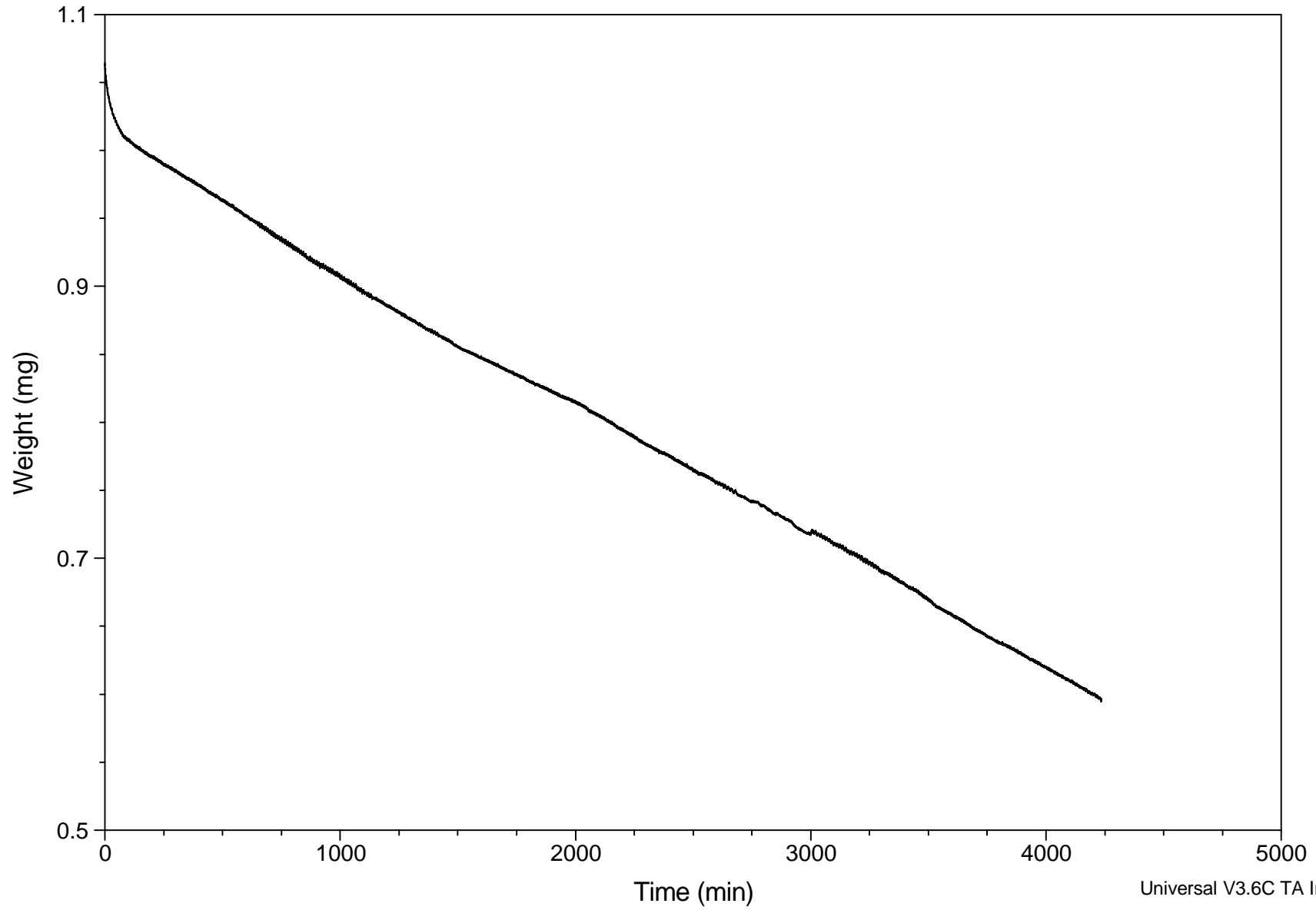

Figure. WEIGHT LOSS OF GD ON ALUMINUM DISKS vs AGGREGATE  
Isothermal @ 30 Degrees C, Relative humidity 0%, Flow Rate 100mL/min

Evaporation of VX on Aluminum  
Isothermal @30C, TGA 2950



Sample: VX-4076 ON WASHED GLASS(T) DISK  
Size: 0.8660 mg  
Method: KBS  
Comment: VX (0.5uL) ON GLASS(T)-WASHED (6mm), @30C, 0%, 1000mL/min

### DSC-TGA

File: C:\...\SDT\TGA-VX\VX\_GLT\_30C\_1000\_0%.00:  
Operator: SHH/RGN  
Run Date: 13-Aug-04 16:11  
Instrument: SDT Q600 V3.9 Build 52

