

# REPORT DOCUMENTATION PAGE

*Form Approved*  
OMB No. 0704-0188

Public reporting burden for this collection of information is estimated to average 1 hour per response, including the time for reviewing instructions, searching existing data sources, gathering and maintaining the data needed, and completing and reviewing this collection of information. Send comments regarding this burden estimate or any other aspect of this collection of information, including suggestions for reducing this burden to Department of Defense, Washington Headquarters Services, Directorate for Information Operations and Reports (0704-0188), 1215 Jefferson Davis Highway, Suite 1204, Arlington, VA 22202-4302. Respondents should be aware that notwithstanding any other provision of law, no person shall be subject to any penalty for failing to comply with a collection of information if it does not display a currently valid OMB control number. **PLEASE DO NOT RETURN YOUR FORM TO THE ABOVE ADDRESS.**

<b>1. REPORT DATE (DD-MM-YYYY)</b> 26-09-2005		<b>2. REPORT TYPE</b> Journal Article		<b>3. DATES COVERED (From - To)</b>	
<b>4. TITLE AND SUBTITLE</b>  <b>Highly Accurate Ignition Delay Apparatus for Hypergolic Fuel Research (PREPRINT)</b>				<b>5a. CONTRACT NUMBER</b>	
				<b>5b. GRANT NUMBER</b>	
				<b>5c. PROGRAM ELEMENT NUMBER</b>	
<b>6. AUTHOR(S)</b> Angelo J. Alfano (ERC); Jeffrey D. Mills & Ghanshyam L. Vaghjiani (AFRL/PRSP)				<b>5d. PROJECT NUMBER</b> 23030423	
				<b>5e. TASK NUMBER</b>	
				<b>5f. WORK UNIT NUMBER</b>	
<b>7. PERFORMING ORGANIZATION NAME(S) AND ADDRESS(ES)</b>  Air Force Research Laboratory (AFMC) AFRL/PRSP 10 E. Saturn Blvd. Edwards AFB CA 93524-7401				<b>8. PERFORMING ORGANIZATION REPORT NUMBER</b>  AFRL-PR-ED-JA-2005-475	
<b>9. SPONSORING / MONITORING AGENCY NAME(S) AND ADDRESS(ES)</b>  Air Force Research Laboratory (AFMC) AFRL/PRS 5 Pollux Drive Edwards AFB CA 93524-7048				<b>10. SPONSOR/MONITOR'S ACRONYM(S)</b>	
				<b>11. SPONSOR/MONITOR'S NUMBER(S)</b> AFRL-PR-ED-JA-2005-475	
<b>12. DISTRIBUTION / AVAILABILITY STATEMENT</b>  Approved for public release; distribution unlimited (AFRL-ERS-PAS-2005-301)					
<b>13. SUPPLEMENTARY NOTES</b> Submitted for publication in Review of Scientific Instruments					
<b>14. ABSTRACT</b> The efficient development of hypergolic fuels requires an interdisciplinary approach involving <i>ab initio</i> modeling, synthesis, and experimental physical chemistry. Candidate molecules must exhibit hypergolic ignition delay times that are fast enough to warrant further testing for safety and performance criteria. Hypergolic ignition delay apparatus has been mentioned in the open literature for six decades but accurate, detailed, modern ignition delay hardware that uses inexpensive laboratory building blocks and a minimum of custom circuitry is still needed. This paper details line-of-sight electro-optical circuitry with direct digital readout and additional oscilloscope recording that can be used to measure total ignition and chemical delay times for screening candidate fuels. We also illustrate the value of high speed video and quantum chemical calculations to supplement the ignition delay measurements for a comprehensive approach to hypergolic fuel research.					
<b>15. SUBJECT TERMS</b>					
<b>16. SECURITY CLASSIFICATION OF:</b>			<b>17. LIMITATION OF ABSTRACT</b>	<b>18. NUMBER OF PAGES</b>	<b>19a. NAME OF RESPONSIBLE PERSON</b>
<b>a. REPORT</b>	<b>b. ABSTRACT</b>	<b>c. THIS PAGE</b>			Dr. Tommy W. Hawkins
Unclassified	Unclassified	Unclassified	A	17	<b>19b. TELEPHONE NUMBER</b> <i>(include area code)</i> N/A

**HIGHLY ACCURATE IGNITION DELAY APPARATUS  
FOR HYPERGOLIC FUEL RESEARCH (PREPRINT)**

Angelo J. Alfano\*, #  
ERC, Inc.  
AFRL/PRSP  
10 E Saturn Blvd  
Edwards AFB, CA 93524

And

Jeffrey D. Mills and Ghanshyam L. Vaghjiani\*  
Propellant Branch  
Space and Missile Propulsion Division  
Propulsion Directorate  
Air Force Research Laboratory  
AFRL/PRSP  
10 E Saturn Blvd  
Edwards AFB, CA 93524

Voice: (661) 275 5657

FAX: (661) 275 5471

Email: [ghanshyam.vaghjiani@edwards.af.mil](mailto:ghanshyam.vaghjiani@edwards.af.mil)

**ABSTRACT**

The efficient development of hypergolic fuels requires an interdisciplinary approach involving *ab initio* modeling, synthesis, and experimental physical chemistry. Candidate molecules must exhibit hypergolic ignition delay times that are fast enough to warrant further testing for safety and performance criteria. Hypergolic ignition delay apparatus has been mentioned in the open literature for six decades but accurate, detailed, modern ignition delay hardware that uses inexpensive laboratory building blocks and a minimum of custom circuitry is still needed. This paper details line-of-sight electro-optical circuitry with direct digital readout and additional oscilloscope recording that can be used to measure total ignition and chemical delay times for screening candidate fuels. We also illustrate the value of high speed video and quantum chemical calculations to supplement the ignition delay measurements for a comprehensive approach to hypergolic fuel research.

#Currently at: Northrop Grumman Space Technology  
One Space Park-R6/1047  
Redondo Beach, CA 90278

## INTRODUCTION

Hypergolic fuel-oxidizer pairs convert the exothermic energy of mixing and the heat of preignition chemical reactions into self sustaining combustion without any external energy source for ignition. The temporal delay from fuel-oxidizer contact to full combustion is known as the ignition delay while the ignition delay for non hypergolic systems is defined as the period from the application of the external ignition stimulus to the onset of combustion. Hypergolic ignition delay for liquids consists of a complex interplay between heat and mass transfer (physical factors) as well as the kinetics for reactive species production and species identity (chemical factors). In the limit of ideal, instantaneous mixing a chemical delay that is characteristic of the specific hypergolic pair would be observed<sup>1</sup> under specific conditions. Clearly the hypergolic ignition delay contains contributions from both the chemical delay and from the recalcitrant physical factors.

Accurate chemical delay measurements for a hypergolic system are important because a minimum chemical delay has been shown to correspond to a maximum specific impulse ( $I_{sp}$ ) in certain variable composition organic fuel mixtures<sup>2</sup>. Therefore, a simple chemical delay measurement provides a good insight into a direct performance metric,  $I_{sp}$ , which is much more difficult to either measure or calculate. It is also believed that a long ignition delay allows for the build up of explosive intermediate species that may detonate upon ignition<sup>3,4</sup>. This undesirable and potentially catastrophic phenomenon is known as a hard engine start in a propulsion application. Therefore, the overall systems reliability may be optimized by minimizing the ignition delay time.

Techniques for hypergolic ignition delay measurement are well referenced and they have been reviewed by others<sup>1</sup>. The methods employ drop tests or stream mixing interaction with optical<sup>1,5,6</sup>, spectroscopic<sup>7</sup>, and high speed video<sup>8</sup> detection of the ignition event to terminate a measurement period that is initiated with reagent contact. Ignition delay for gaseous systems that require an external ignition source are commonly investigated in a shock tube with spectroscopic radical detection<sup>9</sup> of ignition following the registration of the initiating shock wave. IR laser heating has also been used as an ignition source<sup>10</sup>. In this latter case a separate laser was used to generate Rayleigh scatter and an optical multichannel analyzer measured spatially resolved gas density that is reduced as the temperature increases upon ignition. Automotive fuel researchers are also interested in ignition delay measurements and a pressure transducer signifies the ignition event in a system<sup>11</sup> that requires milliliter size sample volumes.

Our interest is in hypergolic liquid fuels with conventional liquid oxidizers such as  $N_2O_4$  and fuming nitric acids. The fuels include low vapor pressure ionic liquids and hydrocarbons that can be converted into substituents that promote hypergolicity in ionic liquids. For screening purposes a simple, inexpensive drop test chemical delay measurement apparatus that uses a minimum sample size is desirable. The following sections provide the details for instrumentation that meets these objectives. The approach is similar to the line-of-sight method described by Smith et. al<sup>1</sup> and it uses electro-optical

means to sense the passing of a falling drop, the onset of pre-ignition vapors, and the flash associated with ignition. The design in reference 1 was based upon the desire to have a minimum delay time external synchronous signal from a digital oscilloscope to trigger other instrumentation, and it used a large expensive ion laser. The design presented below uses a digital oscilloscope, a laser diode, photodiode detectors, and digital timing circuitry and readout to achieve a versatile, simple, and highly accurate system for chemical delay measurement. The building blocks are common laboratory items without extraordinary capability and the oscilloscope is only necessary during initial setup and optimization.

## EXPERIMENTAL

Our simple line-of-sight apparatus for measuring both chemical and total ignition delay is shown schematically in Figure 1. A laser diode (LD1) operating at 655 nm in the red is focused through a glass cuvette and the beam hits photodiode D1 (190-680 nm) upon exiting the cuvette. The diode laser is housed in a temperature controlled mount and it is powered by a constant current source. D1 responds both to the reduction in laser diode transmission due to the falling oxidizer (fuel) droplet and to the onset of pre-ignition vapor formation that follows fuel-oxidizer mixing. The cuvette contains one partner of the hypergolic pair and the other partner is delivered from a syringe. The appearance of pre-ignition vapor signifies the beginning of the chemical delay which terminates in a flash of light when ignition occurs. Photodiode D2 (190-1000 nm) responds to the filtered light emission from this hypergolic ignition event. Both photodiode signals are routed to a two channel digital oscilloscope and to the timing electronics that drive two digital counters. Counters 1 and 2 provide the elapsed time (total clock pulses) from the passage of the drop to incipient pre-ignition vapor production and to the onset of the ignition flash, respectively. Simple subtraction of these two counter outputs gives the duration for pre-ignition vapor production or the chemical delay.

The details of the timing electronics are presented in Figure 2. Photodiode D1 is illuminated by the laser diode, LD1. The cathode output of D1 is capacitively coupled and gives a positive going signal when the transmitted light level from LD1 is reduced by a falling drop or the production of particle laden pre-ignition vapor. A pair of operational amplifiers acts as an adjustable threshold discriminator and a TTL interface for the gating logic that directs the 1 Megahertz clock oscillator to digital counter 1. This counter follows the output of “and” gate 2 that passes clock pulses from the occurrence of a falling drop to the onset of pre-ignition vapor production. The op-amp pair produces a net high to low comparator signal (CLK1). Flip flop FF2 was set to toggle on the high to low transitions from CLK1 and the 74121 one shot pulse was set at 10 ms to prevent FF2 from being affected by any oscillation from the falling drop signal. Photodiode D2 yields a positive going pulse when the hypergolic reaction produces a light flash upon ignition.

An adjustable level discriminator and buffer/TTL interface is also provided by an op-amp pair (CLK2). This portion of the circuit drives digital counter 2 through “and” gate 3 that passes clock pulses from the passage of a falling drop to the ignition flash. The use of a 1 MHz timebase gives the chemical delay directly in microseconds upon subtraction of counter 1 from counter 2. The timebase oscillator is powered from the five volt supply that is used for the op-amps and TTL logic. These TTL compatible oscillators are available in a variety of fixed output frequencies and they can be interchanged to fine tune the timing resolution as dictated by the chemical systems of interest. Since the op-amps operate from a single +5 volt supply, their output voltage swing is unipolar from 0 to +3.5 volts. It was for this reason that photodiodes D1 and D2 were configured to produce positive going signals through their capacitively coupled outputs. Op-amps with bipolar power supply requirements would remove that constraint and permit the use of a positive or negative voltage on the 10 K $\Omega$  trim pots that set the discriminator level. The simplicity of a single voltage power supply could, however, be maintained by using a battery to power D1. A timing diagram is provided in Figure 3 to further illustrate the circuit operation.

A test of the circuit operation was performed by replacing the photodiode outputs in Figures 1 and 2 with two precision pulse/delay generators. The pulse sequences in Figure 4 simulate the falling drop followed by pre-ignition vapor production (lower trace) and the ignition light flash (upper trace). In practice the falling drop signal is 2 to 3 ms FWHM. The pulses that produced the lower and upper traces in Figure 4 become rows CLK1 and CLK2, respectively, in the timing diagram (Figure 3) after exiting the inverting op-amp pairs. The delay between the leading edges of the pulses that simulate the falling drop and the pre-ignition vapor production was set at 15.1234 ms. The delay from the leading edge of the simulated falling drop to the simulated ignition flash was set at 20.2350 ms. The expected chemical delay is then 5111.6  $\mu$ s. Eleven measurements were performed to compare the chemical delay obtained with the digital timing circuit and pulse counters with this 5111.6  $\mu$ s value. The results are listed in Table I where the chemical delay column is the difference between the counter readings and for a 1 MHz clock has units of microseconds. A one-microsecond accuracy was expected and obtained.

The hypergolic pair monomethylhydrazine (MMH) and white fuming nitric acid (WFNA) was chosen to demonstrate the hardware on a real system. A single drop of ~ 0.05 ml of MMH was carefully dispensed from a syringe with a glass capillary terminated Teflon needle into a 1 cm quartz cuvette that contained 1 ml of WFNA. The ignition seemed instantaneous and it was accompanied by an optical flash and an acoustic signature. *It must be emphasized that MMH and WFNA are violently reactive, hazardous, and toxic and only small quantities should be used under well ventilated conditions with carefully planned safety protocols and protective equipment in place.* The lower trace in Figure 5 reproduces the digital oscilloscope output for the falling drop and the pre-ignition vapor production. The upper trace represents the ignition flash. The ignition flash tends to clear pre-ignition vapor from the laser diode beam path and therefore, the rising portion of the top trace and falling portion of the bottom trace are correlated. The threshold for the D1 signal (droplet

and pre-ignition vapor) was set at 0.385 volts and the downward pointing arrow in the lower trace of Figure 5 indicates that this corresponds to the small plateau that is one oscilloscope division below the maximum pre-ignition vapor level. The D2 threshold for the ignition flash was 0.157 volts and this corresponds to the upward pointing arrow in the top trace of Figure 5. Counter 1 and counter 2 gave readings of 44210 and 58993, respectively and this yields a chemical delay of 14.783 ms.

## DISCUSSION

The circuit validation exemplified in Figure 4 and Table I confirms the one microsecond accuracy of the chemical delay measurement with the 1 MHz timebase. However, the results for the MMH-WFNA test (Figure 5) indicate that the measured chemical delay is sensitive to the threshold setting chosen for the op amp pair that follows photodiode D1. A threshold setting corresponding to the beginning of smoke production in Figure 5 would give a chemical delay >21 ms rather than 14.783 ms. Clearly the digital oscilloscope trace is necessary to evaluate the digital counter data and to properly interpret the measured chemical delay.

There is a more serious problem inherent in the line-of-sight chemical delay technique that is revealed in Figure 6. This high speed (500 fps & 640 x 480 pixel resolution) CMOS video camera sequence shows the falling of a 1,2-bicyclopropylacetylene droplet (a potential energetic substituent) into a pool of  $N_2O_4$ . This sequence illustrates the well known facts that a) ignition is a gas phase phenomenon that can occur at a significant distance from the initially mixed liquids and b) multiple ignition sites can occur. (See frames 12 and 13 in Figure 6.) Careful geometric confinement of the pre-ignition vapors would minimize the uncertainty of the ignition location above the liquid pool and the position of the liquid surface can be adjusted relative to the laser beam when using the line-of-sight hardware. Nevertheless, the simple line-of-sight apparatus described here is flexible, accurate, simply constructed, and very useful for screening materials and assessing their potential for hypergolic activity.

The careful separation of the physical dynamics (mixing, interfacial thermal transport, etc.) from the chemical dynamics (initiation reaction step and kinetics, key preignition intermediates, definitive ignition event, etc.) in a low vapor pressure fuel-oxidizer interaction is needed to gain a fundamental understanding of the structure-property relationships that are required to facilitate the design of ionic liquid hypergolic systems. These systems present a challenging problem for fundamental understanding and experiments are ongoing. Our approach is to combine time-resolved diagnostic techniques with the appropriate mixing strategies to isolate the chemical dynamics and to investigate the mechanistic aspects of hypergolicity both experimentally and theoretically. Ultimately reaction paths and kinetics will be determined experimentally

and validated theoretically. The theoretical component of this work has many facets but calculations are underway for gaseous neutral molecules with the intention of progressing to charged species. Enthalpies of abstraction of the hydrazinic hydrogens by NO<sub>2</sub> in N-substituted amino derivatives of both the 1,2,3- and 1,2,4-triazole systems were calculated<sup>12</sup> at the B3LYP(VWN5)/ 6-311++G(d,p)// B3LYP(VWN5)/ 6-311++G(d,p) level of theory<sup>13-18</sup> (Figure 7). These values are slightly above the range (0.9-4.2 kcal/mol) calculated at the same level of theory for hydrazine and MMH and experimentally the substituted triazole molecules are less reactive with N<sub>2</sub>O<sub>4</sub>. For example, solid 1-amino-1,2,3-triazole reacts vigorously but not hypergolically with nitrogen tetroxide (see reaction F in Figure 7).

## CONCLUSION

The chemical delay apparatus presented above is a valuable screening tool for use in conjunction with high speed video, time-resolved spectroscopy, and quantum chemical calculations in hypergolic fuel research. Measurement of the chemical delay alone could be used by synthesis chemists to evaluate and select synthetic targets. The circuitry in Figure 2 functions well either on a breadboard or with simple wire-wrap fabrication and the other items are readily available.

## REFERENCES

1. S. Hampton, K.K. Ramesh, and J. E. Smith Jr., AIAA 41<sup>st</sup> Aerospace Sciences Meeting and Exhibit, AIAA-2003-1359, Jan. 6-9, 2003.
2. K. Kishore and M. R. Sunitha, *Propellants and Explosives* **2**, 98 (1977).
3. T. Christos, Y. Miron, H. James, and H. Perlee, *J. Spacecraft* **4**, 1224 (1967).
4. M. Saad, M. Detweiler, and M. Sweeney, *AIAA Journal* **10**, 1073 (1972).
5. S. Kulkarni and S. P. Panda, *Combust. Flame* **40**, 29 (1981).
6. S. R. Jain and K. N. Murthy, *Combust. Flame* **81**, 403 (1990).
7. D. G. Patil, S. R. Jain, and T. B. Brill, *Propellants, Explos., Pyrotech.* **17**, 260 (1992).
8. W. Daimon, Y. Gotoh, and I. Kimura, *J. Propulsion* **7**, 946 (1991).

9. C. J. Brown and G. O. Thomas, *Combust. Flame* **117**, 861 (1999).
10. M. Tanoff, M. Smooke, R. Teets, and J. Sell, *Combust. Flame* **103**, 253 (1995).
11. L. Allard, N. Hole, G. Webster, T. Ryan, D. Ott, A. Beregszazy, C. Faitbridge, J. Cooley, K. Mitchell, E. Richardson, N. Elliot, and D. Rickeard, SAE Technical Paper Series 971636; 1997.
12. M. W. Schmidt, K. K. Baldrige, J. A. Boatz, S. T. Elbert, M. S. Gordon, J. H. Jensen, S. Koseki, N. Matsunaga, K. A. Nguyen, S. Su, T. L. Windus, M. Dupuis, and J. A. Montgomery, *J. Comput. Chem.* **14**, 1347(1993).
13. A. D. Becke, *J. Chem. Phys.* **98**, 5648 (1993).
14. P. J. Stephens, F. J. Devlin, C. F. Chabalowski, and M. J. Frisch, *J. Phys. Chem.* **98**, 11623 (1994).
15. R. H. Hertwig and W. Koch, *Chem. Phys. Lett.* **268**, 345 (1997).
16. R. Krishnan, J. S. Binkley, R. Seeger, and J. A. Pople, *J. Chem. Phys.* **72**, 650 (1980).
17. M. J. Frisch, J. A. Pople, and J. S. Binkley, *J. Chem. Phys.* **80**, 3265 (1984).
18. T. Clark, J. Chandrasekhar, G. W. Spitznagel, and P. V. R. Schleyer, *J. Comput. Chem.* **4**, 294 (1983).

**Table I.** Test data for chemical delay measurements (readings in microseconds).

<b>COUNTER 1</b>	<b>COUNTER 2</b>	<b>CHEMICAL DELAY</b>
15124	20236	5112
15124	20235	5111
15124	20236	5112
15124	20235	5111
15124	20236	5112
15124	20235	5111
15124	20235	5111
15124	20236	5112
15124	20235	5111
15124	20236	5112
15124	20235	5111

## FIGURE CAPTIONS

**Figure 1.** Schematic diagram of line-of-sight hypergolic ignition delay time apparatus.

**Figure 2.** Electro optical and digital interface circuitry.

**Figure 3.** Timing diagram for circuitry in Figure 2.

**Figure 4.** Simulated signal for falling droplet and pre-ignition vapor generation (lower trace) and for ignition light flash (top trace).

**Figure 5.** Actual signals for the hypergolic ignition of MMH and WFNA. Falling MMH drop and pre-ignition vapor production (lower trace). Light flash upon ignition (upper trace).

**Figure 6.** High speed video showing spatially resolved ignition event for a droplet of 1,2-bicyclopropylacetylene falling into nitrogen tetroxide.

**Figure 7.** Thermally corrected (298 K) enthalpies (kcal mol<sup>-1</sup>) for isomerization (reactions A and D) and hydrogen abstraction by nitrogen dioxide to produce *trans*-HONO for 1-Amino-1-H- and 4-Amino-4-H-1,2,4 triazole (reactions C and B) and for 1-Amino-1-H- and 2-Amino-2-H-1,2,3-triazole (reactions F and E) at the B3LYP(VWN5)/6-311++G(d,p)// B3LYP(VWN5)/6-311++G(d,p) level of theory.

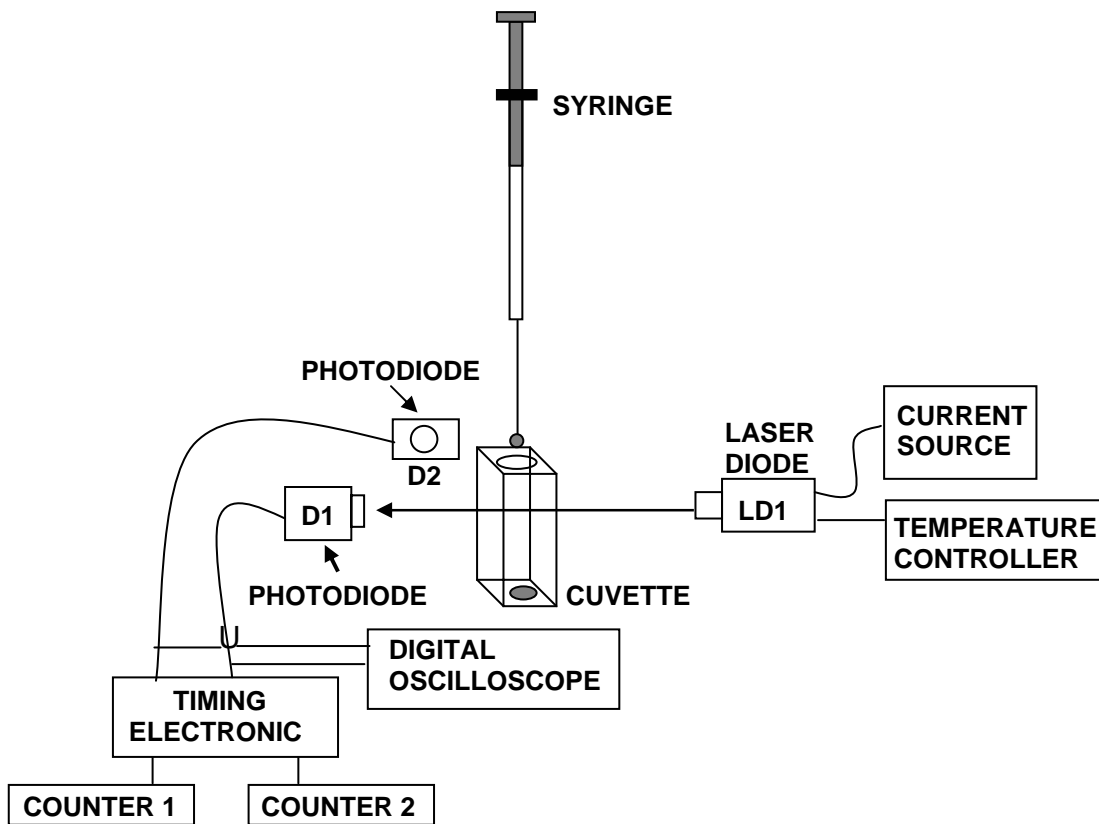

Figure 1.

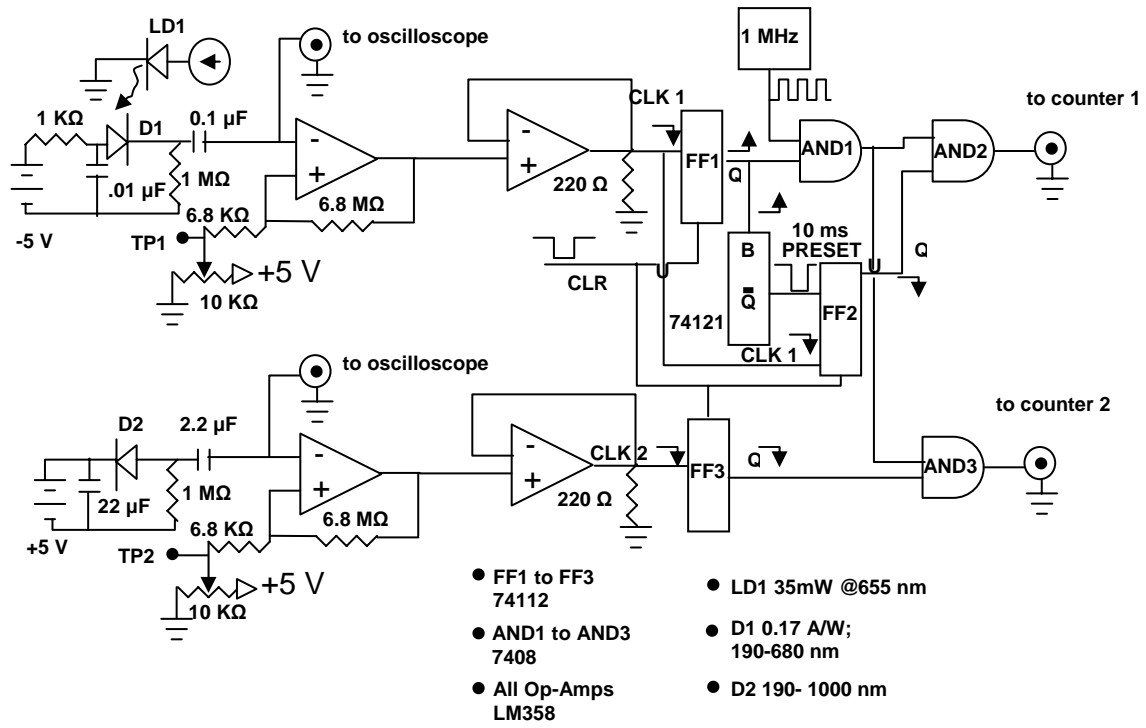

Figure 2.

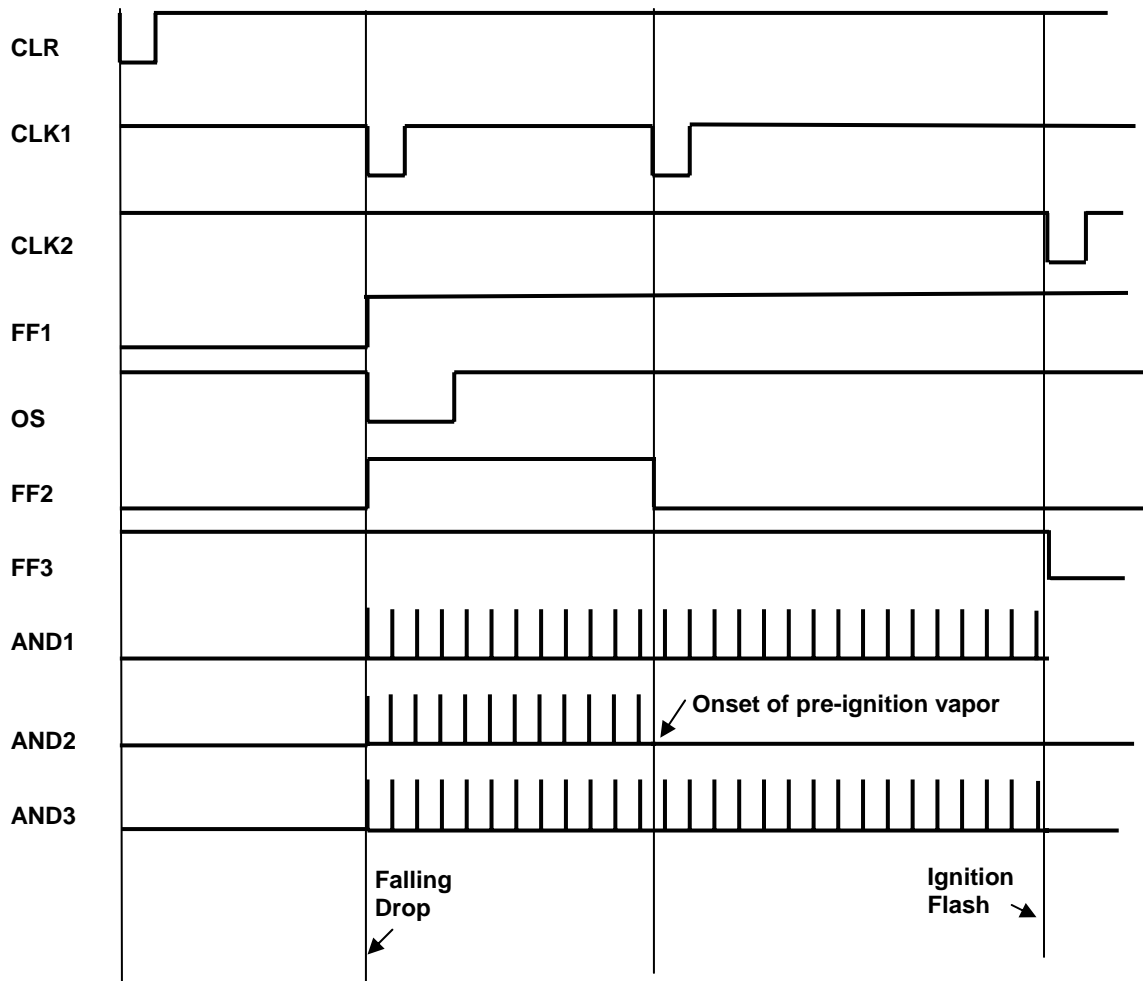
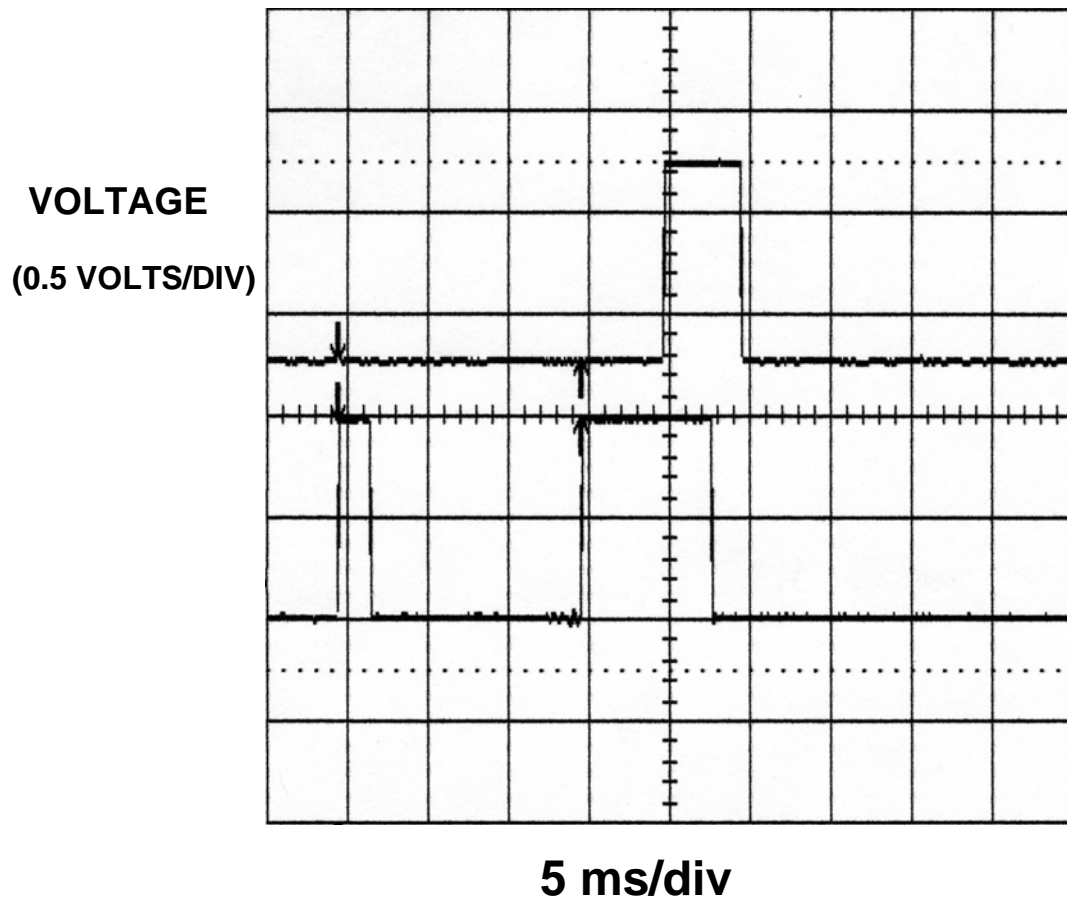
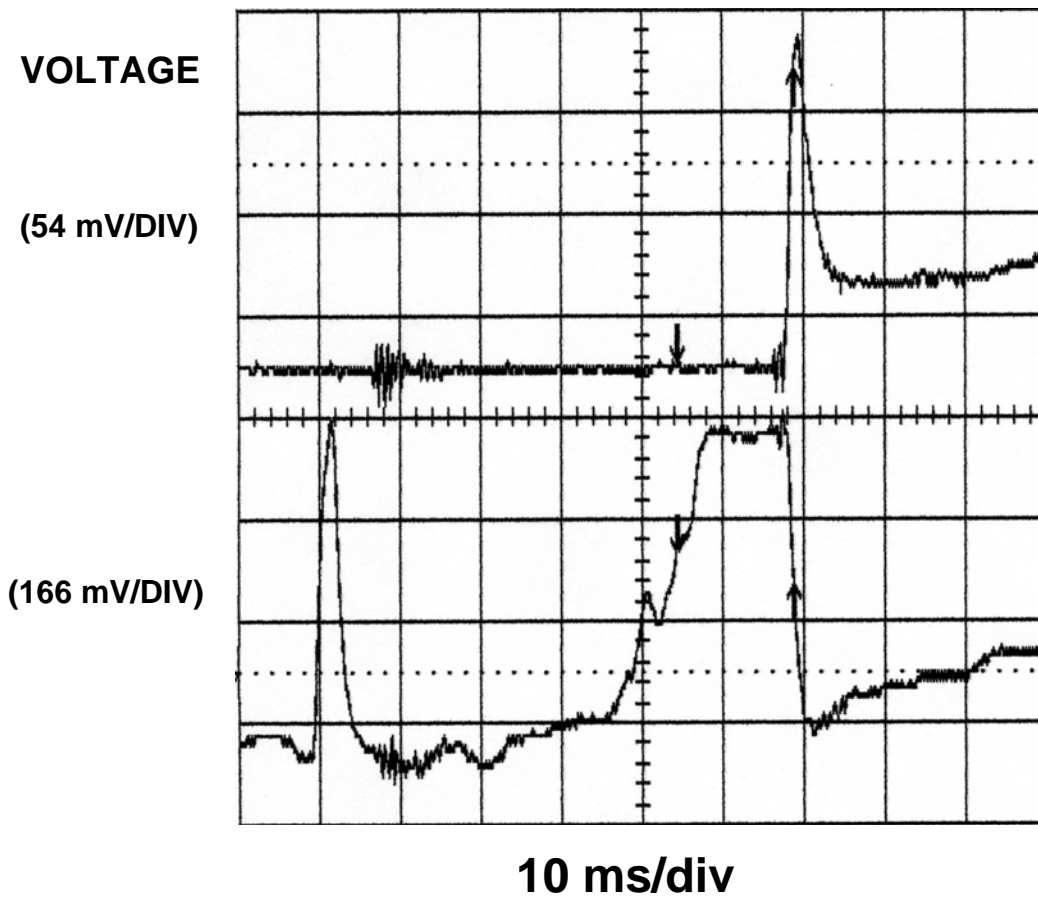

Figure 3.



**Figure 4.**



**Figure 5.**

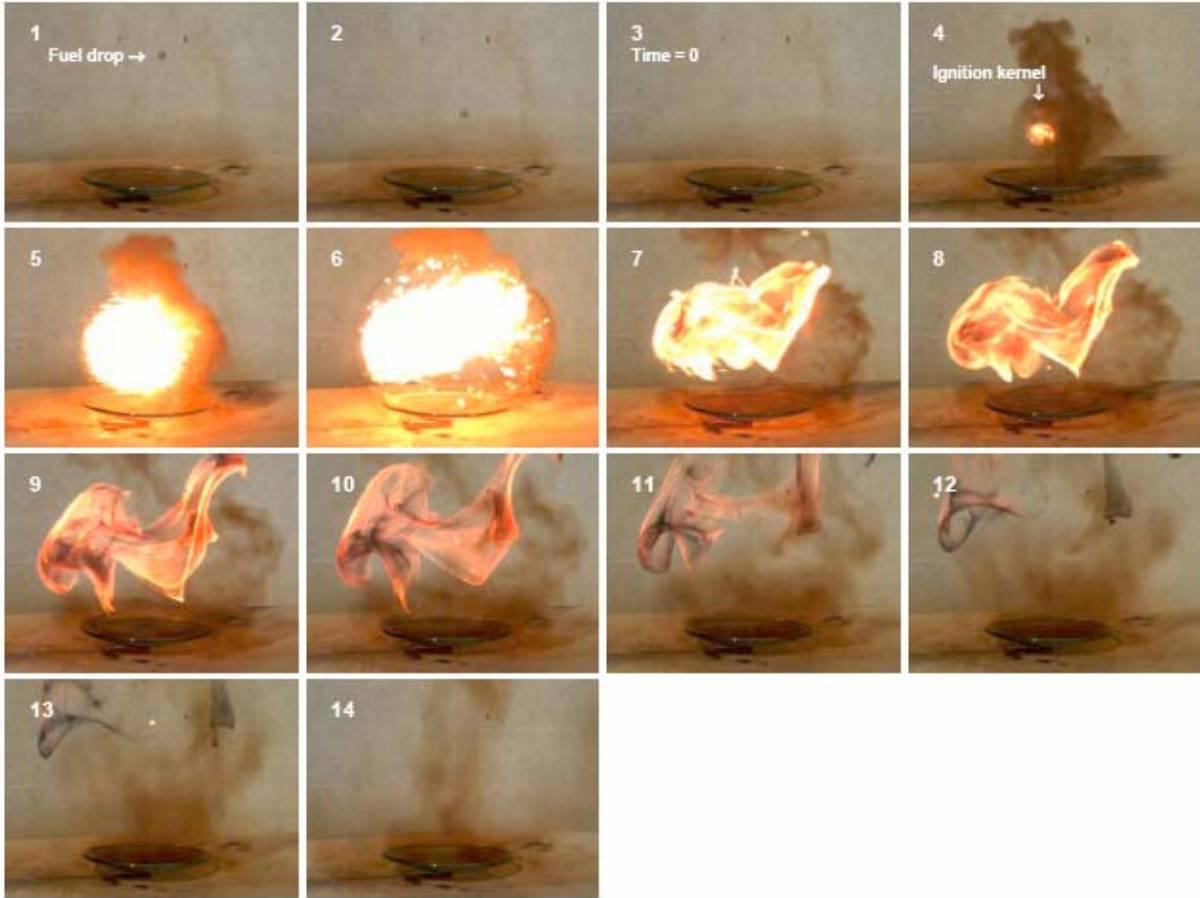
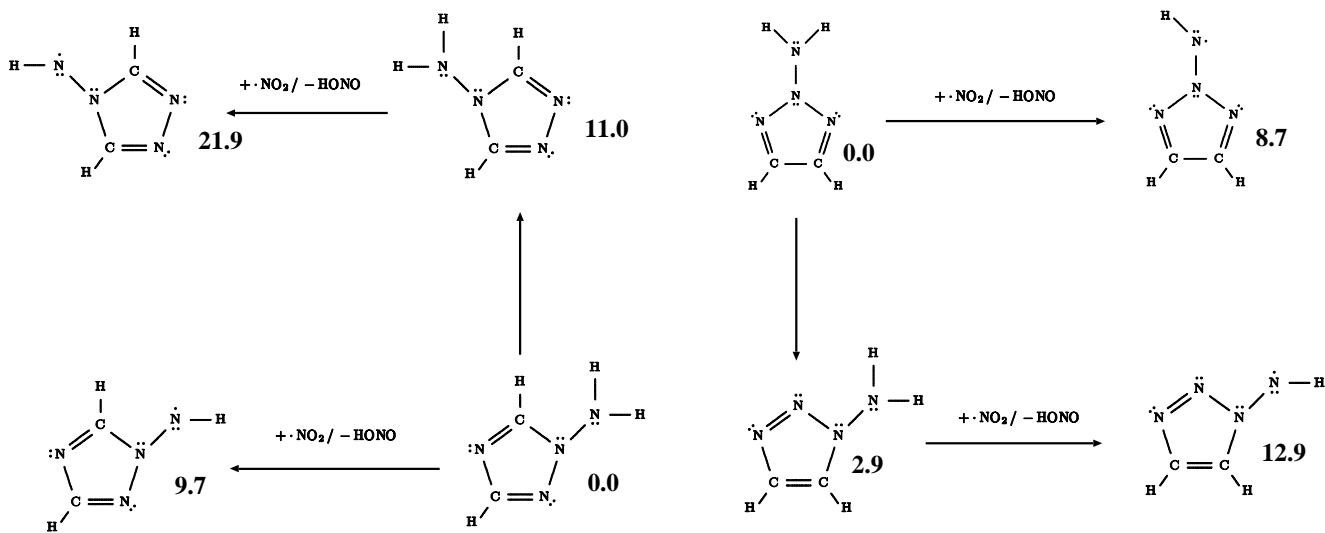

Figure 6.



**Figure 7.**