



**Biological Fuel Cell Functional as an
Active or Reserve Power Source**

by Charles W. Walker, Jr. and Alyssa L. Walker

ARL-TR-3840

June 2006

NOTICES

Disclaimers

The findings in this report are not to be construed as an official Department of the Army position unless so designated by other authorized documents.

Citation of manufacturer's or trade names does not constitute an official endorsement or approval of the use thereof.

Destroy this report when it is no longer needed. Do not return it to the originator.

Army Research Laboratory

Adelphi, MD 20783-1197

ARL-TR-3840

June 2006

Biological Fuel Cell Functional as an Active or Reserve Power Source

**Charles W. Walker, Jr. and Alyssa L. Walker
Sensors and Electron Devices Directorate, ARL**

Approved for public release; distribution unlimited.

REPORT DOCUMENTATION PAGE

*Form Approved
OMB No. 0704-0188*

Public reporting burden for this collection of information is estimated to average 1 hour per response, including the time for reviewing instructions, searching existing data sources, gathering and maintaining the data needed, and completing and reviewing the collection information. Send comments regarding this burden estimate or any other aspect of this collection of information, including suggestions for reducing the burden, to Department of Defense, Washington Headquarters Services, Directorate for Information Operations and Reports (0704-0188), 1215 Jefferson Davis Highway, Suite 1204, Arlington, VA 22202-4302. Respondents should be aware that notwithstanding any other provision of law, no person shall be subject to any penalty for failing to comply with a collection of information if it does not display a currently valid OMB control number.

PLEASE DO NOT RETURN YOUR FORM TO THE ABOVE ADDRESS.

1. REPORT DATE (DD-MM-YYYY) June 2006		2. REPORT TYPE Final		3. DATES COVERED (From - To) November 2004 to February 2005	
4. TITLE AND SUBTITLE Biological Fuel Cell Functional as an Active or Reserve Power Source				5a. CONTRACT NUMBER	
				5b. GRANT NUMBER	
				5c. PROGRAM ELEMENT NUMBER	
6. AUTHOR(S) Charles W. Walker, Jr. and Alyssa L. Walker				5d. PROJECT NUMBER	
				5e. TASK NUMBER	
				5f. WORK UNIT NUMBER	
7. PERFORMING ORGANIZATION NAME(S) AND ADDRESS(ES) U.S. Army Research Laboratory ATTN: AMSRD-ARL-SE-DC 2800 Powder Mill Road Adelphi, MD 20783-1197				8. PERFORMING ORGANIZATION REPORT NUMBER ARL-TR-3840	
9. SPONSORING/MONITORING AGENCY NAME(S) AND ADDRESS(ES) U.S. Army Research Laboratory 2800 Powder Mill Road Adelphi, MD 20783-1197				10. SPONSOR/MONITOR'S ACRONYM(S)	
				11. SPONSOR/MONITOR'S REPORT NUMBER(S)	
12. DISTRIBUTION/AVAILABILITY STATEMENT Approved for public release; distribution unlimited.					
13. SUPPLEMENTARY NOTES					
14. ABSTRACT A biological fuel cell was constructed in which the metabolism of glucose by yeast provides the electrons. A two-compartment plexiglas ¹ fuel cell was constructed with platinum electrodes separated by a proton-conducting membrane. One half of the cell contained yeast, <i>Saccharomyces cerevisiae</i> , glucose, and an electron mediator, methylene blue. The other half contained an electron acceptor, potassium ferricyanide. Electrons produced during the metabolism of glucose by the yeast were captured by the methylene blue and transferred to the platinum electrode, traveled through the external circuit to the cathode compartment, and were finally accepted by the potassium ferricyanide. When yeast was added to the fuel cell, the open circuit potential was ~0.5 V. Electrical current was measured while the cell voltage was held at 0.3 V and 0.1 V. Current output was optimized for initial concentration of yeast, temperature, glucose concentration, agitation, and oxygen content. The optimum conditions for producing current within the scope of this study were obtained with agitated, partially oxygenated electrolyte at 45 °C containing 0.1 M glucose. ¹ Plexiglas is a registered trademark of Altuglas International.					
15. SUBJECT TERMS Biological fuel cell, yeast, power, reserve cell, <i>Saccharomyces cerevisiae</i>					
16. SECURITY CLASSIFICATION OF:			17. LIMITATION OF ABSTRACT UL	18. NUMBER OF PAGES 26	19a. NAME OF RESPONSIBLE PERSON Charles W. Walker, Jr.
a. REPORT Unclassified	b. ABSTRACT Unclassified	c. THIS PAGE Unclassified			19b. TELEPHONE NUMBER (Include area code) (301) 394-0306

Contents

List of Figures	iv
Acknowledgment	v
1. Introduction	1
2. Experimental	2
2.1 Fuel Cell Construction.....	2
2.2 Stock Solutions.....	4
2.3 General Procedure	4
2.4 Optimization Tests	5
3. Results and Discussion	6
3.1 Cell Inoculum Concentration	7
3.2 Temperature.....	7
3.3 Glucose Concentration	9
3.4 Stagnant versus Agitated Solution	10
3.5 Aerobic versus Anaerobic Conditions.....	10
3.6 Active and Reserve Configurations.....	11
4. Conclusion	13
5. References	15
Distribution List	17

List of Figures

Figure 1. Construction diagram of the plexiglas fuel cell.....	3
Figure 2. Schematic of the biological fuel cell system.	3
Figure 3. Open circuit cell potential followed over time. (Yeast inoculated at $t = -30$ min. Experiments were started at $t = 0$ min.)	5
Figure 4. Fuel cell current over time for a complete cell without yeast (A), and for a cell with yeast but without any added glucose (B).	6
Figure 5. Electrical power generated as a function of concentration of yeast inoculum at $30\text{ }^{\circ}\text{C}$ and 0.1 M glucose. (Cell voltage was stepped from OCV to 0.3 V for 5 minutes, then stepped to 0.1 V for 5 minutes. Average current at the end of 5 minutes was used to calculate power.)	7
Figure 6. Electrical current produced as a function of temperature with 20 mg ml^{-1} of yeast inoculum and 0.1 M glucose. (Cell voltage was stepped from OCV to 0.3 V for 5 minutes, then stepped to 0.1 V for 5 minutes.).....	8
Figure 7. Power generated as a function of cell temperature.....	8
Figure 8. Power generated as a function of glucose concentration for 20 mg ml^{-1} yeast inoculum at $30\text{ }^{\circ}\text{C}$	9
Figure 9. The effect of solution agitation at $45\text{ }^{\circ}\text{C}$ and 0.1 M glucose with 20 mg ml^{-1} yeast inoculum held at 0.3 V	10
Figure 10. Comparison of the effect of oxygen-saturated (lower trace) and anoxic (upper trace) solutions on current at $45\text{ }^{\circ}\text{C}$ and 0.1 M glucose with 20 mg ml^{-1} yeast inoculum held at 0.3 V for 1 hour. 11	
Figure 11. Reserve pouch cell configuration.	13

Acknowledgment

The authors wish to thank the U.S. Army Research Laboratory for support of this project.

INTENTIONALLY LEFT BLANK.

1. Introduction

The need to supply more power for the Soldier to operate numerous electronic devices is creating a physical burden since many batteries must be carried, especially on long missions. Advances in battery technology have not yet satisfied the need, so other energy-dense alternatives such as fuel cells are being considered. Although the concept of fuel cells was developed by Sir William Grove in 1839, the current search for renewable energy sources has stimulated interest in the development of practical commercial systems as well as those for military use. There is considerable effort to develop devices to provide power for applications ranging from small consumer electronics such as cell phones to automobiles and stationary power plants (e.g., to power a building). Fuel cell technologies are also being considered for other very low power applications such as body-implanted drug pumps (1,2), unattended ground sensors for military purposes (1,3), and on-chip power for microelectronics (1,4 through 6).

Although a hydrogen/air fuel cell is preferred, the infrastructure to handle, store, and distribute hydrogen gas does not currently exist. However, other readily obtainable fuels can be used, such as methanol, natural gas, gasoline, and diesel fuel. However, these fuels generally require complex reforming processes to extract and purify hydrogen before being fed into the fuel cell. A variation of this technology is the biological fuel cell, which can use live microbes or immobilized enzymes to produce hydrogen (7,8), or more commonly, can directly provide electrons derived from the metabolic pathways that produce energy. Electron mediators are often needed to transfer electrons from the microbe to an electrode (9 through 11) or enzyme to the electrode (4,12 through 16), but in some cases, electrons are transferred directly (17 through 22). Recently, the direct transfer of electrons was shown to occur via highly conductive pili which create an electrical connection or biological nanowire between the bacterial cell and insoluble Fe(III) oxides (22). These pili were required to reduce the oxide, since pili-deficient cells could no longer reduce insoluble oxides.

In this study, we demonstrate a biological fuel cell “powered” by ordinary dry Baker’s yeast, *Saccharomyces cerevisiae*, without the need for sterilization procedures or the maintenance of live cultures or labile enzymes. Yeast grow rapidly in aerobic and anaerobic conditions, have simple nutritional requirements, and can use a wide variety of substrates, which make them ideal for a biological fuel cell. A commercial off-the-shelf (COTS) yeast preparation is preferable to immobilized enzymes which, by comparison, are expensive, difficult to isolate, substrate specific, and much more sensitive to environmental parameters such as temperature and pH. A two-compartment fuel cell similar to one designed by Bennetto (9) was constructed with platinum electrodes separated by a proton-conducting membrane. One half of the cell contained yeast, *Saccharomyces cerevisiae*, glucose, and an electron mediator, methylene blue. The oxidation-reduction mediator enters the outer cell membrane and becomes reduced, and then

leaves in the reduced state. The reduced mediator transfers the captured electrons to an electrode, producing an electric current and re-oxidizing the methylene blue. The other half of the cell contained an electron acceptor, potassium ferricyanide, which accepts the electrons from the circuit and becomes reduced. Oxygen in the catholyte will oxidize Fe^{2+} back to Fe^{3+} . Ferricyanide was preferred as the electron acceptor over an oxygen-saturated solution because we did not want significant oxygen diffusion through the membrane into the anode compartment where it would oxidize the methylene blue before the methylene blue could transfer electrons to the electrode.

The optimization of several independent variables to maximize production of electricity was determined. We show here the effect of temperature, substrate concentration, quiescent versus agitated solutions, oxygen-rich versus anoxic solutions, and the influence of yeast inoculum concentration on electrical output.

2. Experimental

2.1 Fuel Cell Construction

Two halves of the fuel cell were constructed from 2.4-cm-thick plexiglas with a 6.5-cm x 6.5-cm chamber machined into one face (1.5 cm deep) and two holes drilled from one edge (figure 1). One hole was for the electrode lead wire and the other for the addition of solution. Both electrodes were made of platinum mesh (4 cm x 5 cm) with platinum wire leads to enable indefinite use without corrosion or fouling. Electrically insulating but ionically conducting Nafion 117 proton exchange membrane was treated to remove impurities and prepare it in the H^+ form by boiling the film for 1 h each step in 3% H_2O_2 , deionized water, 0.5 M H_2SO_4 , and deionized water. The Nafion membrane was sandwiched between two rubber gaskets and bolted between the two halves of the fuel cell to create two compartments. Each compartment was filled with deionized water when not in use to maintain hydration of the Nafion which is essential for good proton conductivity. A schematic of the system is shown in figure 2. The light bulb illustrates a simulated load and not the actual setup. The open circuit voltage (OCV) of the cell was ~ 0.5 V.

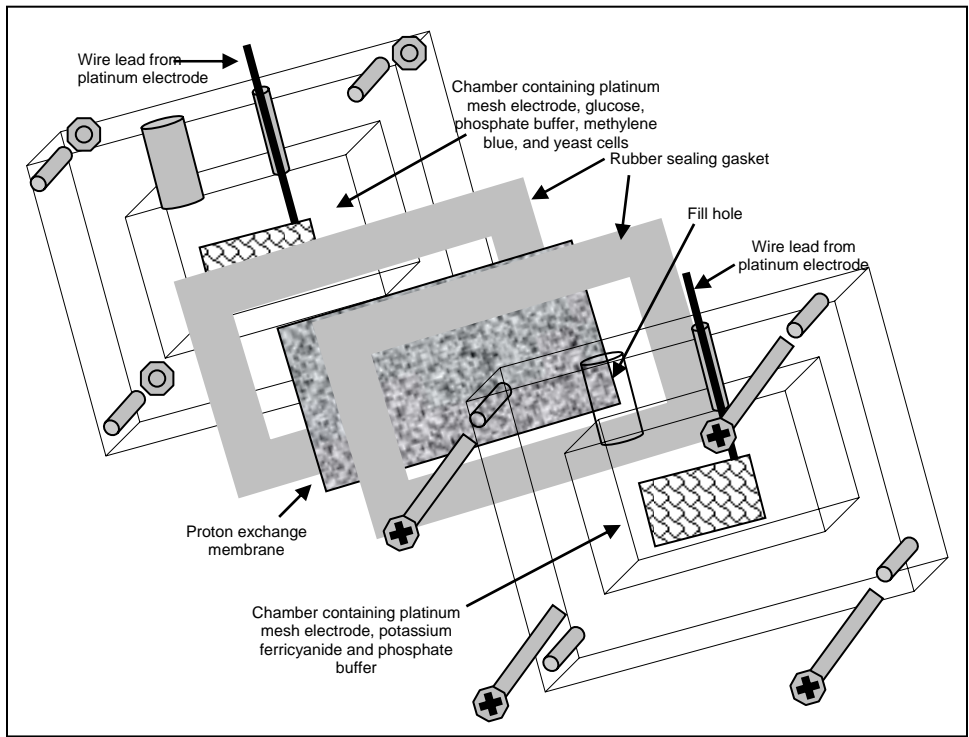

Figure 1. Construction diagram of the plexiglas fuel cell.

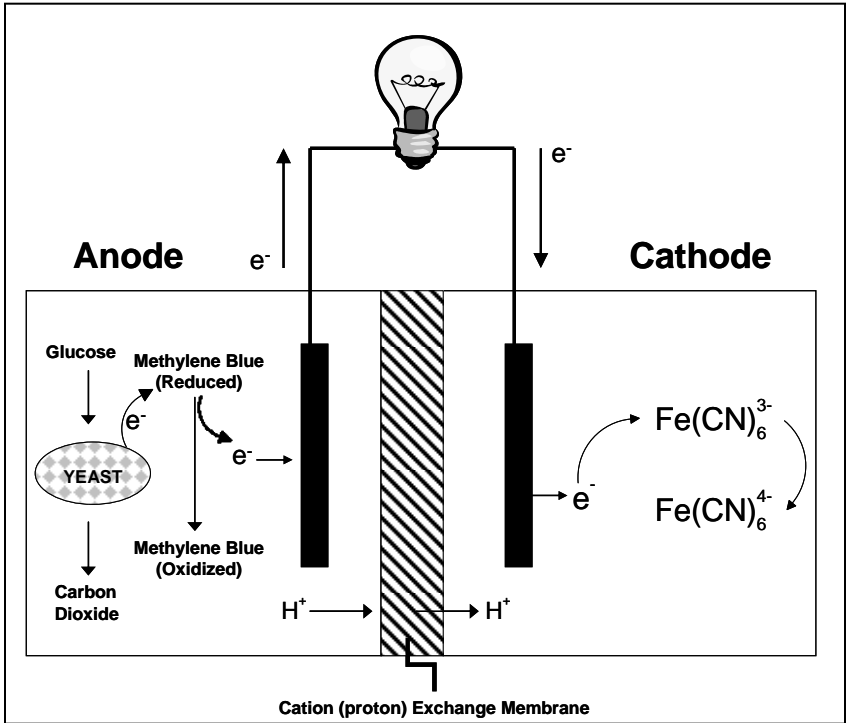

Figure 2. Schematic of the biological fuel cell system.

2.2 Stock Solutions

0.1 M phosphate buffer (Na_2HPO_4 and NaH_2PO_4), 10 mM methylene blue in phosphate buffer, 0.1 M potassium ferricyanide in phosphate buffer, and 1.0 M and 0.2 M D-glucose in phosphate buffer (all Aldrich Chemical) were prepared with demineralized water. Fleischmann's Dry Rapid Rise Yeast which contains nutrients to promote rapid growth was the source of *Saccharomyces cerevisiae*.

2.3 General Procedure

In one half of the cell (anode), a 50:50 mixture of glucose and methylene blue solutions produced final concentrations of 0.1 M and 0.005 M, respectively. The other half (cathode) contained an equal volume of 0.1 M potassium ferricyanide. The cell was placed in a Tenney environmental chamber to control and equilibrate temperature before each experiment. The electrical leads of the platinum electrodes were attached to an EG&G Princeton Applied Research Model 273 potentiostat/galvanostat with M270 software under computer control. Chronoamperometry (current measured over time) experiments were performed by stepping cell potential from OCV to 0.3 V and measuring current output each 0.5 s for 5 minutes, followed by stepping voltage to 0.1 V for 5 minutes while measuring current. When applicable, oxygen or argon was bubbled into the anode compartment via a glass Pasteur pipette connected to a flow meter to deliver 100 ml min^{-1} of gas to agitate the solution or to establish oxygen-rich and anoxic conditions. It is not particularly important to know the exact number of yeast cells being used if the same quality-controlled commercial source of yeast is used, so inoculum size is given by mass instead. To weigh a mass simplifies having to determine and deliver a certain cell number from solution. We prepared yeast as a slurry by mixing with a few milliliters of phosphate buffer immediately before adding it to the anode compartment with a disposable polyethylene transfer pipet. We mixed the cells briefly by drawing solution and dispensing it back into the anode compartment. A period of 30 minutes was allowed for yeast to grow before we began each experiment. This was based on the observation of OCV after inoculation illustrated in figure 3. When the cells are added ($t = -30 \text{ min.}$), the OCV steadily rises above 0.5 V. The OCV peaks within the first 10 minutes, then decreases slightly to a near steady state when the experiment is begun ($t = 0 \text{ min.}$). The two controls were a) a complete cell without addition of yeast b) a complete cell without addition of glucose. Independent variables were amount of yeast inoculum, temperature, glucose concentration, \pm stirring, \pm oxygen. The dependent variable was the current output harnessed from the yeast.

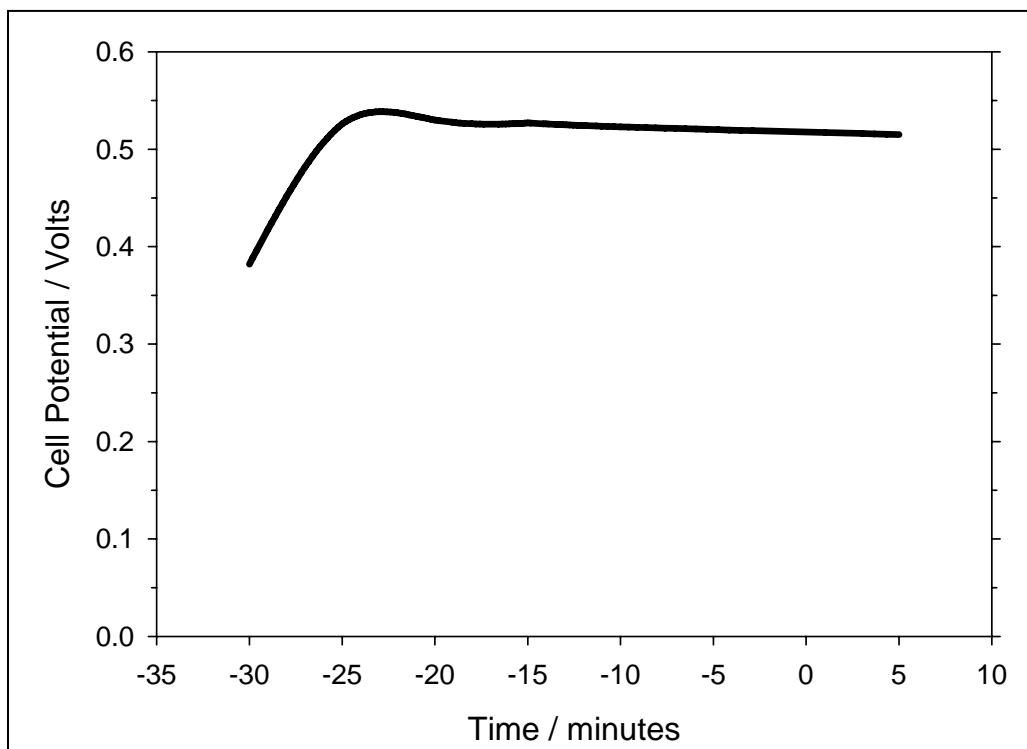

Figure 3. Open circuit cell potential followed over time. (Yeast inoculated at $t = -30$ min. Experiments were started at $t = 0$ min.)

2.4 Optimization Tests

The optimum amount of yeast inoculum was determined for the conditions of $30\text{ }^{\circ}\text{C}$ with 0.1 M glucose. Enough yeast was weighed to produce final concentrations ranging from 1 to 35 mg ml^{-1} . A 5-minute test period was arbitrarily chosen for each voltage step. The current measured at the end of 5 minutes was reported since this value approaches equilibrium and most clearly demonstrates differences. The effect of temperature from $10\text{ }^{\circ}\text{C}$ to $55\text{ }^{\circ}\text{C}$ was performed with 20 mg ml^{-1} yeast inoculated after equilibrating cell temperature in a Tenney environmental chamber. Glucose concentration tests were done at $30\text{ }^{\circ}\text{C}$ with 20 mg ml^{-1} yeast for glucose concentrations of 0 , 0.1 , and 0.5 M . Stirred solutions were created by bubbling argon at 100 ml min^{-1} through a Pasteur pipette inserted into the anode compartment following a period of quiescent conditions. Oxygen-rich and anoxic solutions were prepared by bubbling of oxygen and argon, respectively, for 30 minutes before inoculation of yeast. Experiments were performed at least three times and results were averaged.

3. Results and Discussion

Two control experiments to determine baseline values are shown in figure 4. A control experiment without any yeast gave an OCV of about 0.175 V and baseline current of 2 μA . When potential was driven to 0.1 V the current increased about 3.5 μA . Short circuit current was only 18.5 μA . This established that the fuel cell without yeast was non-functional as a power source. In a second cell containing yeast but without any added glucose, the OCV quickly reached about 0.5 V and baseline current was approximately 150 μA . Current was above 200 μA when voltage was stepped to 0.3 V and approximately 275 μA when stepped to 0.1 V.

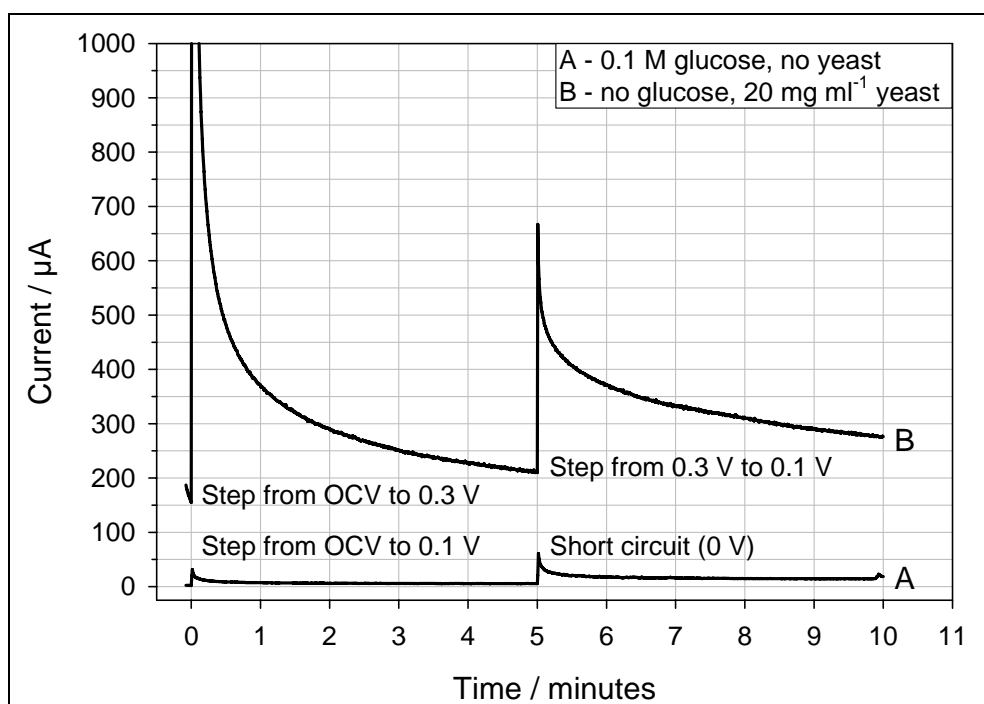

Figure 4. Fuel cell current over time for a complete cell without yeast (A), and for a cell with yeast but without any added glucose (B).

In all the optimization experiments, high current spikes were observed when the cell potential was stepped from OCV to 0.3 V. This occurs because methylene blue has accepted electrons with few being transferred to the electrode. Once the load is applied, a significant transfer of electrons occurs, similar to the discharging of a capacitor. A steady state equilibrium is subsequently established, determined by the rate of glucose metabolism, electron transfer to the mediator, and diffusion of the mediator to the electrode.

3.1 Cell Inoculum Concentration

Inoculation of a low number of cells (1 mg ml^{-1}) results in a low current response because of the low number of electron donors, but once a sufficient number of cells were present (about 20 mg ml^{-1}), the current response (and therefore power) was maximized (figure 5). Although there is some uncertainty in this value shown by the error bar for the cell held at 0.3 V , this seems a reasonable choice and the data for the cell held at 0.1 V tend to support this conclusion. The addition of an excessive number of cells did not improve response and is an inefficient use of cells.

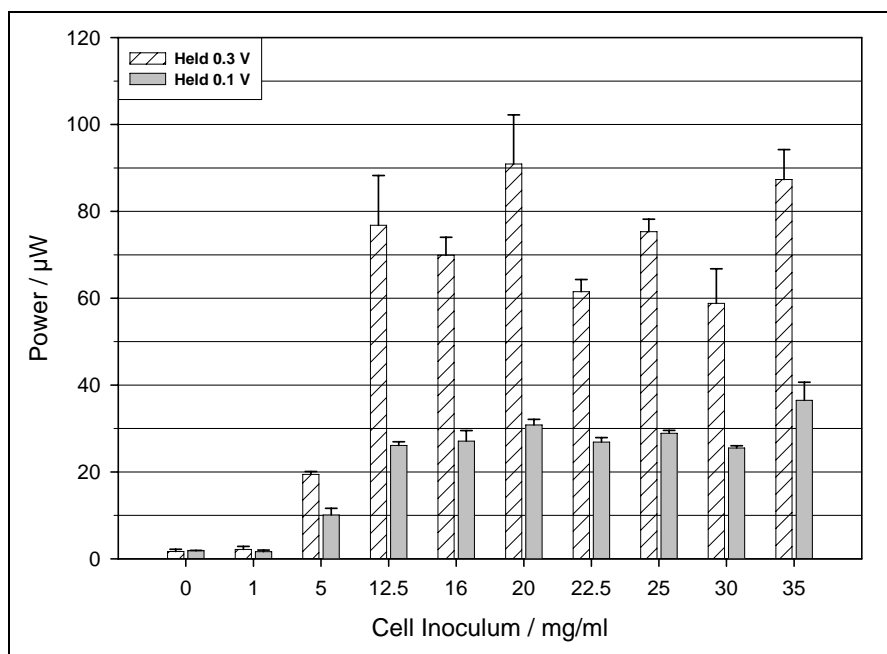

Figure 5. Electrical power generated as a function of concentration of yeast inoculum at $30 \text{ }^\circ\text{C}$ and 0.1 M glucose. (Cell voltage was stepped from OCV to 0.3 V for 5 minutes, then stepped to 0.1 V for 5 minutes. Average current at the end of 5 minutes was used to calculate power.)

3.2 Temperature

The effect of temperature on current response is shown in figure 6 where typical chrono-amperometric curves are shown for five temperatures. Optimal temperature for the cell conditions outlined in section 2.4 at 0.3 V was $45 \text{ }^\circ\text{C}$, although at 0.1 V , $50 \text{ }^\circ\text{C}$ was optimal (figure 7). Differences may be attributed to normal distribution and the low number of replications used to calculate the average. The power delivered by the fuel cell held at 0.3 V and 0.1 V is shown in figure 7. Although current is greater at 0.1 V less power is attained. Since the higher power was obtained at $45 \text{ }^\circ\text{C}$, this was taken as the optimal value. Average power increased from over $20 \text{ } \mu\text{W}$ at $10 \text{ }^\circ\text{C}$ to about $90 \text{ } \mu\text{W}$ at $30 \text{ }^\circ\text{C}$ and nearly $130 \text{ } \mu\text{W}$ at $45 \text{ }^\circ\text{C}$.

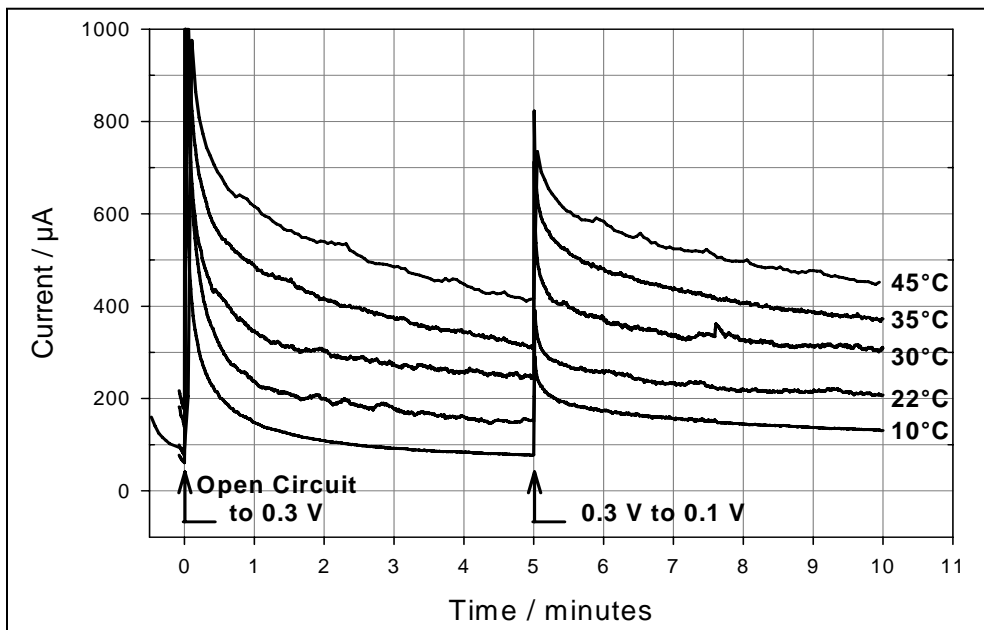

Figure 6. Electrical current produced as a function of temperature with 20 mg ml^{-1} of yeast inoculum and 0.1 M glucose. (Cell voltage was stepped from OCV to 0.3 V for 5 minutes, then stepped to 0.1 V for 5 minutes.)

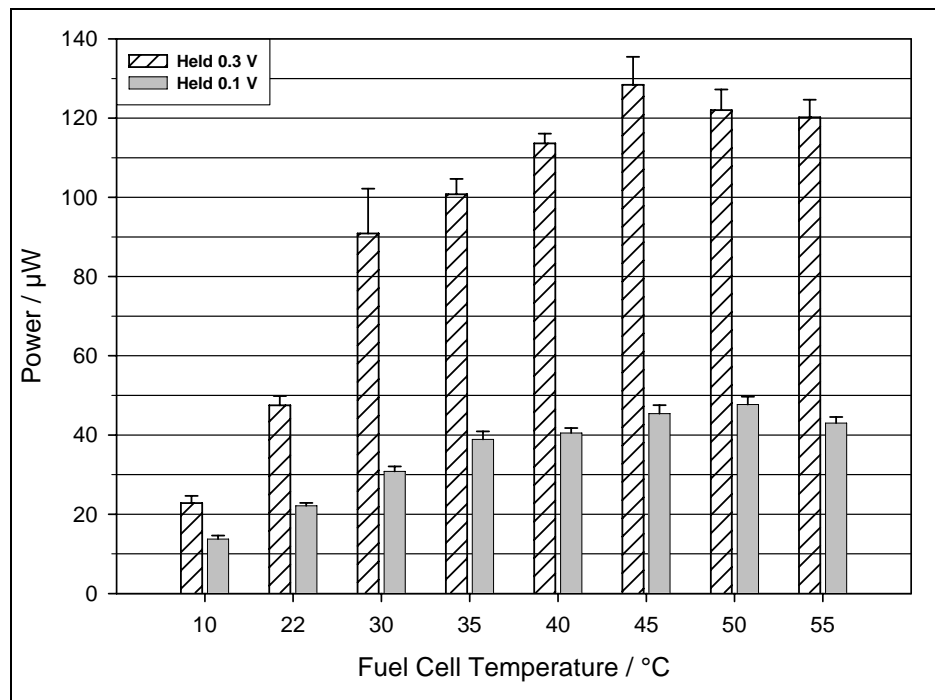

Figure 7. Power generated as a function of cell temperature.

3.3 Glucose Concentration

Because yeast contains endogenous stored energy and “rapid rise” yeast is processed to contain additional nutrients to promote rapid growth, there is significant cell growth even without the addition of any glucose. Without an external load, a current of about 155 μA is produced. When cell potential is driven to 0.3 V, an additional current of about 70 μA (average value) is realized. At 0.1 V, current increases about 135 μA to around 290 μA . Apparently, the endogenous and added energy sources are sufficient to allow nearly maximal growth over the short time periods used in these experiments since addition of glucose at a concentration of 0.1 M shows only a modest increase in current response. Current response is converted to power and shown in figure 8. A high glucose concentration of 0.5 M is of no additional benefit. This result was not unexpected because even in aerobic conditions *S. cerevisiae* can simultaneously grow via respiration or fermentation in a condition of high glucose concentration. Termed the “Crabtree effect” (23,24), genes used for respiration are repressed and fermentation predominates. Although growth rate remains high, fermentation yields much less energy than oxidative respiration of glucose. Exceeding this limiting threshold of glucose concentration is illustrated in figure 8, where the power is lowest at 0.5 M glucose concentration. Any benefit of excessive glucose would be expected to become evident over longer term operation of the fuel cell. These experiments are yet to be conducted.

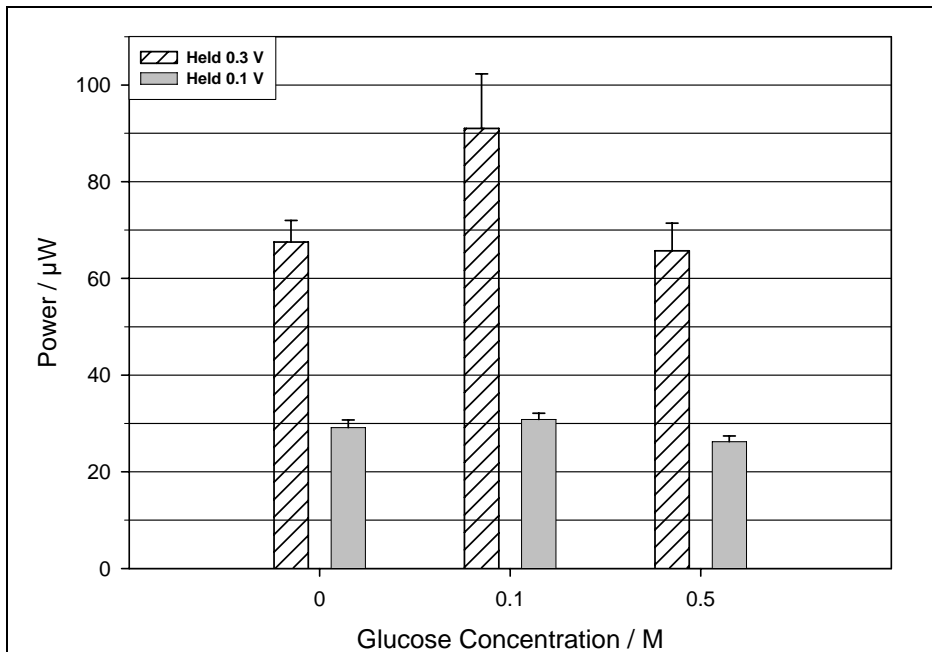

Figure 8. Power generated as a function of glucose concentration for 20 mg ml⁻¹ yeast inoculum at 30 °C.

3.4 Stagnant versus Agitated Solution

Current response is diffusion limited since it is a function of the proximity of the yeast to the platinum electrode and is ultimately controlled by the diffusion of methylene blue to the platinum electrode. Even in stagnant conditions, some self mixing occurs because of CO₂ evolution by yeast. Agitation or stirring of the solution eliminates this diffusion-limited condition. Figure 9 shows an increase of about 40% in current response when a stagnant solution is agitated by bubbling argon.

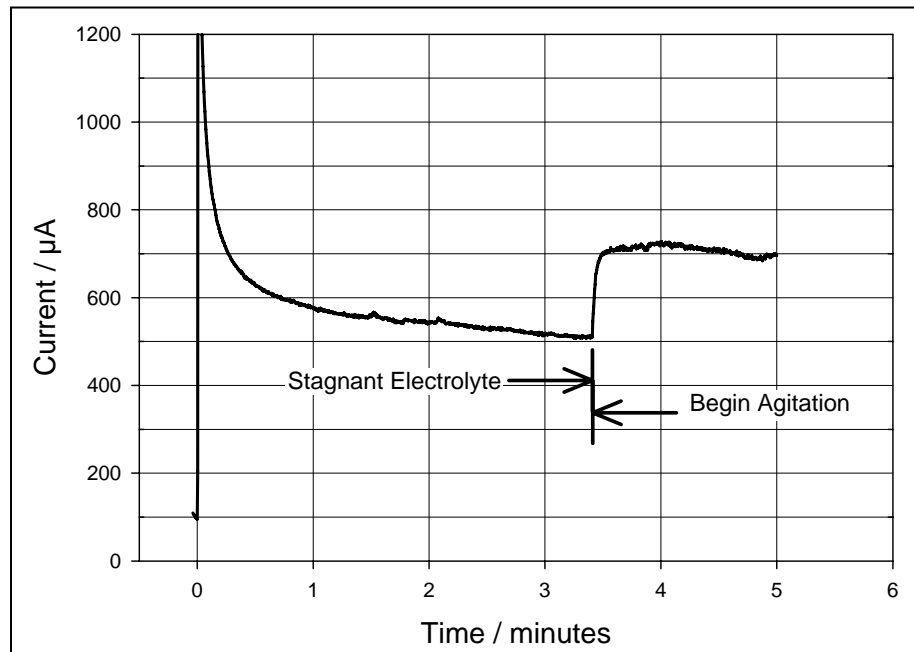
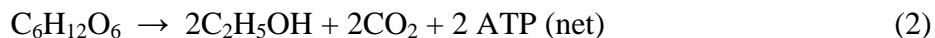
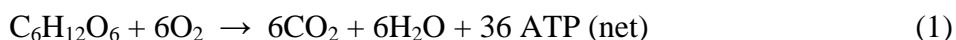

Figure 9. The effect of solution agitation at 45 °C and 0.1 M glucose with 20 mg ml⁻¹ yeast inoculum held at 0.3 V.

3.5 Aerobic versus Anaerobic Conditions

Yeast are facultative aerobes, able to use glucose aerobically and anaerobically. In addition to storing energy in the cell in the form of adenosine triphosphate (ATP), the end products of aerobic respiration are CO₂ and H₂O (equation 1) and the end products of fermentation are ethanol and CO₂ (equation 2).



Aerobic respiration more efficiently uses glucose and produces more energy (i.e., electrons) than fermentation. Three ATP are produced per two electrons. If a mediator accepts the electrons instead of oxygen, one molecule of glucose can provide as many as 24 electrons that may contribute to cell current (equation 3). Fermentation yields only 4/3 electrons per molecule of glucose.



Figure 10 shows the current delivered when cells were inoculated into oxygen-rich and anoxic solutions and current response followed for 60 minutes. Once equilibrium is reached, current response is fairly stable. A higher current response would be expected with the oxygenated electrolyte, but this is not observed. The lower response in the oxygenated solution can be explained by the fact that oxygen will oxidize methylene blue, so in this oxygen-rich environment, many of the electrons from the reduced form of methylene blue are captured by oxygen before they can be transferred to the electrode. The higher initial currents during the first few minutes in the anaerobic environment are most likely explained by this mechanism.

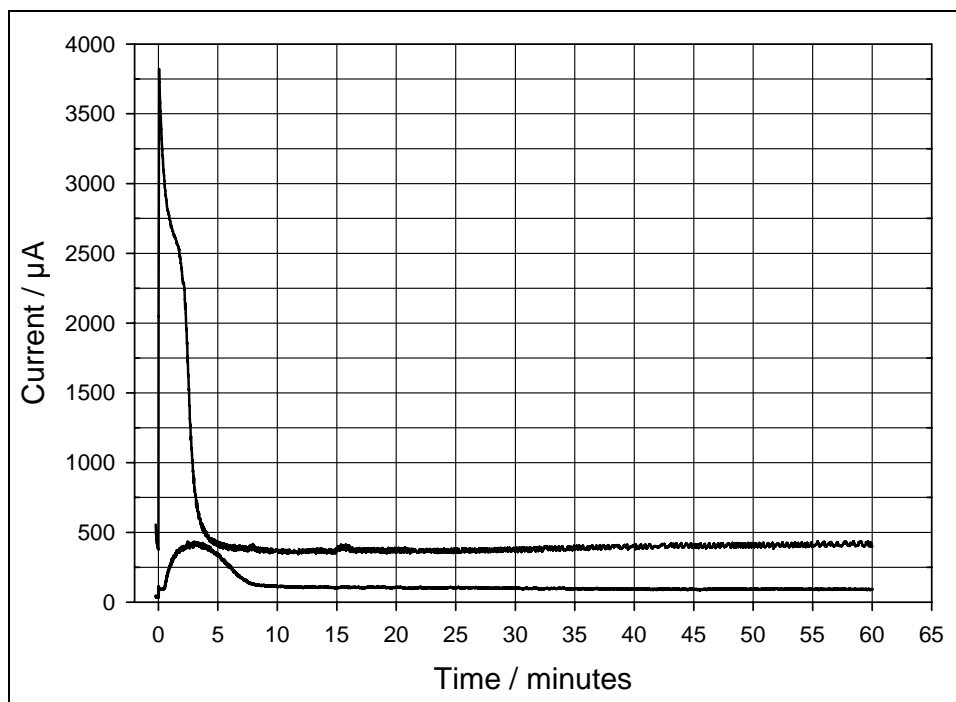

Figure 10. Comparison of the effect of oxygen-saturated (lower trace) and anoxic (upper trace) solutions on current at 45 °C and 0.1 M glucose with 20 mg ml⁻¹ yeast inoculum held at 0.3 V for 1 hour.

The optimal condition seems to be when a moderate amount of oxygen is available. In comparing figure 9 where some oxygen is present to figure 10 with oxygen-saturated or deoxygenated solutions, it is evident that the presence of some oxygen (ambient air contains ~21% O₂) results in obtaining higher currents by allowing maximum cell metabolism with a minimum of competition by oxygen to oxidize methylene blue.

3.6 Active and Reserve Configurations

Active fuel cell operation should be long lived. The platinum screen electrodes will provide unlimited electrode life, thus enabling the cell to be used, stored, and reused indefinitely without

electrode replacement. Occasional replacement of the Nafion membrane (as yet undetermined) may be the only maintenance required. With continuous use, supplying fuel is a simple matter of withdrawing some of the anode solution containing the spent yeast, glucose, methylene blue, phosphate buffer mixture and replacing it with fresh glucose, methylene blue, phosphate buffer solution. The addition of fresh yeast cells is unnecessary since sufficient numbers of active cells will sustain the process. When not in use, a stored cell can be quickly activated if the water is poured out and the appropriate prepared solutions are added to the cell, or alternatively, one can add ampoules of the dry components that will quickly be dissolved in water.

Because no active live organisms are used, this fuel cell is also amenable for use as a reserve cell. All components may be stored in the dry state and the cell activated by hydration with water. A very compact, inexpensive reserve cell could be produced with “pouch cell” technology. Here, the Pt electrodes could be replaced by inexpensive high surface area carbon electrodes since this is a single-use application intended for a finite operating life. The surface area of carbon electrodes ranges from 60 to 1500 m² g⁻¹. A high surface area enhances electron transfer from the methylene blue mediator, thereby increasing current. One possible design is shown in figure 11. The dry components would be stored on the outside of a bladder filled with water or phosphate buffer that also contains the Nafion membrane and carbon electrodes. A simple squeezing of the pinch points punctures the bladder and releases its contents. A few gentle squeezes of the pouch would facilitate mixing of the components and complete cell activation.

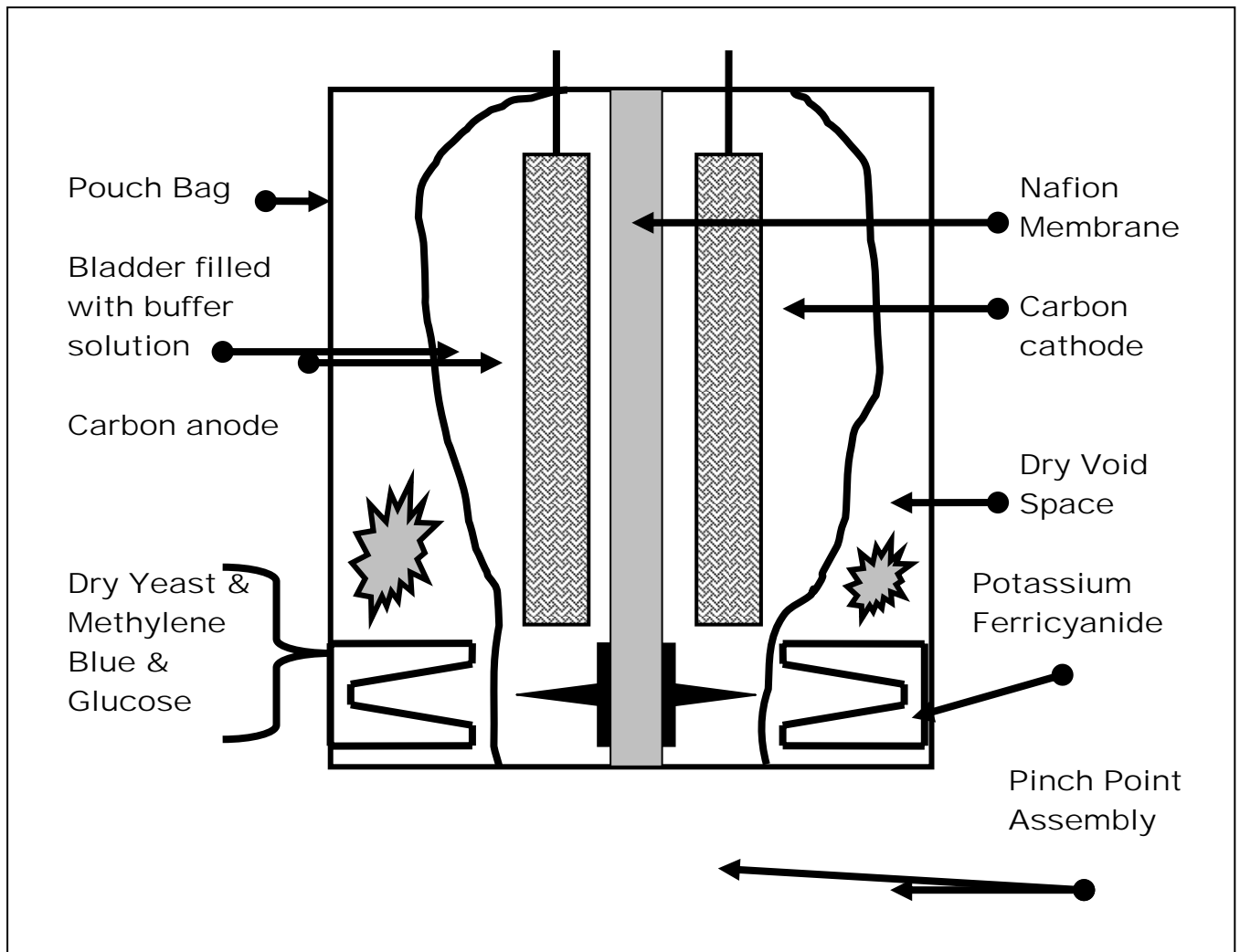

Figure 11. Reserve pouch cell configuration.

4. Conclusion

A biological fuel cell powered by the metabolism of glucose by yeast was optimized for concentration of yeast inoculum, temperature, and glucose concentration. The effect of agitation and oxygen content was also studied. The advantage of using Baker's yeast is that it is inexpensive and readily available, does not require sterile conditions, is not substrate specific, and tolerates a wide range of environmental conditions. As long as a COTS source of yeast is used, an appropriate mass of yeast can be used as inoculum. The ability to quickly weigh the yeast is a huge benefit that eliminates the time and labor of preparing and maintaining a purified culture and determining cell concentration. Another advantage is that all the fuel cell

components could be stored or transported in the dry state and then simply activated by hydration with water.

The optimum conditions within the scope of those used in this study for producing current were obtained with a yeast inoculum concentration of 20 mg ml^{-1} in agitated, partially oxygenated electrolyte maintained at $45 \text{ }^\circ\text{C}$ and containing 0.1 M glucose. Low power ($> 20 \text{ } \mu\text{W}$) can be delivered even at a cool temperature of $10 \text{ }^\circ\text{C}$, but power peaks ($\sim 130 \text{ } \mu\text{W}$) at about $45 \text{ }^\circ\text{C}$. This suggests that devices held near the body, used in desert environments, or mounted in proximity to heat-releasing electronic devices would provide ideal conditions.

Over the short time period used in these experiments, glucose concentration had a modest effect on current output to 0.1 M . At a high concentration of 0.5 M , energy output was slightly suppressed, resulting from the Crabtree effect. Electrolyte agitation increased current because electron transfer was no longer limited by diffusion of methylene blue. Although the presence of oxygen will permit the greatest net number of electrons per glucose molecule, it will compete to oxidize methylene blue before electron transfer to the electrode. In anaerobic conditions, fermentation provides fewer electrons per unit of glucose yet seems to support higher power since all the electrons are transferred from the mediator to the electrode instead of to oxygen. The preferred conditions may be different if fuel cell operation continues for longer periods of time and will also likely show the influence of accumulated end products, high cell concentration, and cell death.

Applications for the biological fuel cell might include devices only needing microwatt power, light emitting diodes, trickle charging capacitors, powering retrievable unattended ground sensors, and micro-electromechanical machines. Reserve pouch cells are an inexpensive alternative amenable to emergency low power such as to charge a capacitor to permit transmission of an emergency beacon or other data, disposable unattended ground sensors, and other single use miniature devices.

5. References

1. Pescovitz, D. The Power of Small Tech, Small Times Media 2002. www.smalltimes.com/document_display.cfm?document_id=37030
2. Pescovitz, D. Body Battery, Berkeley Eng. Lab Notes vol.2 issue 6 Aug 2002. www.coe.berkeley.edu/labnotes/0802/body.html
3. Patil, A. S.; Dubois, G.; Sifer, N.; Bostic, E.; Gardner, K.; Quah, M.; Bolton, C. Bolton. Portable fuel cell systems for America's army: technology transition to the field. *J. Power Sources* **2004**, *136*, 220–225.
4. Moore, C. M.; Minter, S. D.; Martin, R. S. Microchip-based ethanol/oxygen biofuel cell. *Lab on a Chip* **2002**, *5*, 218–225.
5. Shah, K.; Shin, W. C.; Besser, R. S. Novel microfabrication approaches for directly patterning PEM fuel cell membranes. *J. Power Sources* **2003**, *123*, 172–181.
6. Wainright, J. S.; Savinell, R. F.; Liu, C. C.; Litt, M. Microfabricated Fuel Cells. *Electrochimica acta* **2003**, *48*, 2869–2877.
7. Karube, I.; Ikemoto, H.; Kajiwara, K.; Tamiya, E.; Matsuoka, H. Matsuoka. Photochemical energy conversion using immobilized blue-green algae. *J. of Biotechnol* **1986**, *4*, 73–80.
8. Tanisho, S.; Kamiya, N.; Wakao, N. Microbial fuel cell using. *Enterobacter aerogenes*, *J. Electroanal. Chem.* **1989**, *275*, 25–32.
9. Bennetto, H. P. Electricity generation by microorganisms. *Biotechnology Education*. **1990**, *1*, 163–168. Also see www.ncbe.reading.ac.uk.
10. Park, D. H.; Zeikus, J. G. Electricity generation in microbial fuel cells using neutral red as an electronophore. *Appl. and Environ. Microbiol* **2000**, *66*, 1292–1297.
11. Tanaka, K.; Vega, C. A.; Tamamushi, R. Thionine and ferric chelate compounds as coupled mediators in microbial fuel cells. *Bioelectrochemistry and Bioenergetics* **1983**, *11*, 289–297.
12. Palmore, G.T.R.; Bertschy, H.; Berengans, S. H.; Whitesides, G. M. A methanol/dioxygen biofuel cell that uses NAD⁺-dependent dehydrogenases as catalysts: application of an electro-enzymatic method to regenerate nicotinamide adenine dinucleotide at low overpotentials. *J. Electroanal. Chem* **1998**, *443*, 155–161.
13. Mano, N.; Mao, F.; Heller, A. Characteristics of a Miniature Compartment-less Glucose-O₂ Biofuel Cell and Its Operation in a Living Plant. *J. Amer. Chem. Soc.* **2003**, *125*, 6588–6594.

14. Soukharev, V.; Mano, N.; Heller, A. A Four-Electron O₂-Electroreduction Biocatalyst Superior to Platinum and a Biofuel Cell Operating at 0.88 V. *J. Amer. Chem. Soc.* **2004**, *126*, 8368–8369.
15. Topcagic, S.; Minteer, S. D. Development of a membraneless ethanol/oxygen biofuel cell. *Electrochimica acta* **2006**, *51*, 2168–2172.
16. Mano, N.; Heller, A. *J. Electrochem. Soc.* **2003**, *150*, A1136–A1138.
17. Bond, D. R.; Lovley, D. R. Electricity production by *Geobacter sulfurreducens* attached to electrodes. *Appl. and Environ. Microbiol* **2003**, *69*, 1548–1555.
18. Jang, J. K.; Pham, T. H.; Chang, I. S.; Kang, K. H.; Moon, H.; Cho, K. S.; Kim, B. H. Construction and operation of a novel mediator- and membrane-less microbial fuel cell. *Process Biochemistry* **2004**, *39*, 1007–1012.
19. Chaudhuri, S. K.; Lovley, D. R. Electricity generation by direct oxidation of glucose in mediatorless microbial fuel cells. *Nature Biotechnology* **2003**, *21*, 1229–1232.
20. Gil, G. C.; Chang, I. S.; Kim, B. H.; Kim, M.; Jang, J. K.; Park, H. S.; Kim, H. J. Operational parameters affecting the performance of a mediator-less microbial fuel cell. *Biosensors and Bioelectronics* **2003**, *18*, 327–334.
21. Kim, H. J.; Park, H. S.; Hyun, M. S.; Chang, I. S.; Kim, M.; Kim, B. H. A Mediator-less Microbial Fuel Cell Using a metal Reducing Bacterium. *Shewanella putrefaciens*, *Enzyme and Microbial Technol* **2002**, *30*, 145–152.
22. Reguera, G.; McCarthy, K. D.; Mincoll, T.; Tuominen, M. T.; Lovley D. R. Extracellular Electron Transfer via Microbial Nanowires. *Nature* **2005**, *435*, 1098–1101.
23. Postma, E.; Verduyn, C.; Scheffers, W. A.; Van Dijken, J. P. Enzymatic Analysis of the Crabtree Effect in Glucose-Limited Chemostat Cultures of *S. cerevisiae*. *Appl. and Environ. Microbiol.* **1989**, *55*, 468–477.
24. Raghevendran, V.; Nielson, J.; Olsson, L. Teaching microbial Physiology Using Glucose Repression Phenomenon in Baker's Yeast as an Example. *Biochem. and Mol. Biol. Education* **2005**, *33*, 404–410.

Distribution List

ADMNSTR
DEFNS TECHL INFO CTR
ATTN DTIC-OCF (ELECTRONIC COPY)
8725 JOHN J KINGMAN RD STE 0944
FT BELVOIR VA 22060-6218

DARPA
ATTN IXO S WELBY
3701 N FAIRFAX DR
ARLINGTON VA 22203-1714

OFC OF THE SECY OF DEFNS
ATTN ODDRE (R&AT)
THE PENTAGON
WASHINGTON DC 20301-3080

US ARMY TRADOC
BATTLE LAB INTEGRATION & TECHL
DIRCTRT
ATTN ATCD-B
10 WHISTLER LANE
FT MONROE VA 23651-5850

SMC/GPA
2420 VELA WAY STE 1866
EL SEGUNDO CA 90245-4659

COMMANDING GENERAL
US ARMY AVN & MIS CMND
ATTN AMSAM-RD W C MCCORKLE
REDSTONE ARSENAL AL 35898-5000

US ARMY CERDEC
ATTN AMSRD-CER-C2-AP-BA T
ATWATER
FT MONMOUTH NJ 07703

US ARMY INFO SYS ENGRG CMND
ATTN AMSEL-IE-TD F JENIA
FT HUACHUCA AZ 85613-5300

US ARMY SIMULATION TRAIN &
INSTRMNTN CMND
ATTN AMSTI-CG M MACEDONIA
12350 RESEARCH PARKWAY
ORLANDO FL 32826-3726

US GOVERNMENT PRINT OFF
DEPOSITORY RECEIVING SECTION
ATTN MAIL STOP IDAD J TATE
732 NORTH CAPITOL ST., NW
WASHINGTON DC 20402

US ARMY RSRCH LAB
ATTN AMSRD-ARL-CI-OK-TP TECHL
LIB T LANDFRIED (2 COPIES)
ABERDEEN PROVING GROUND MD
21005-5066

DIRECTOR
US ARMY RSRCH LAB
ATTN AMSRD-ARL-RO-EV W D BACH
PO BOX 12211
RESEARCH TRIANGLE PARK NC 27709

US ARMY RSRCH LAB
ATTN AMSRD-ARL-CI-OK-T TECHL
PUB (2 COPIES)
ATTN AMSRD-ARL-CI-OK-TL TECHL
LIB (2 COPIES)
ATTN AMSRD-ARL-D J M MILLER
ATTN AMSRD-ARL-SE-DC
C LUNDGREN
ATTN AMSRD-ARL-SE-DC C WALKER
(10 COPIES)
ATTN AMSRD-ARL-SE-EO
D STRATIS-CULLUM
ATTN IMNE-ALC-IMS MAIL &
RECORDS MGMT
ADELPHI MD 20783-1197

INTENTIONALLY LEFT BLANK