

TECHNICAL REPORT
NATICK/TR-06/018



AD _____

DEVELOPMENT OF A FIGHT LOAD CARRIER VHF BODY-BORNE ANTENNA SYSTEM

by
Joseph T. Merenda
and
John F. Pedersen

BAE Systems, Inc.
Greenlawn, NY 11740-1606

June 2006

Final Report
September 1999 – July 2002

Approved for public release; distribution is unlimited

Prepared for
U.S. Army Research, Development and Engineering Command
Natick Soldier Center
Natick, Massachusetts 01760-5019

DISCLAIMERS

The findings contained in this report are not to be construed as an official Department of the Army position unless so designated by other authorized documents.

Citation of trade names in this report does not constitute an official endorsement or approval of the use of such items.

DESTRUCTION NOTICE

For Classified Documents:

Follow the procedures in DoD 5200.22-M, Industrial Security Manual, Section II-19 or DoD 5200.1-R, Information Security Program Regulation, Chapter IX.

For Unclassified/Limited Distribution Documents:

Destroy by any method that prevents disclosure of contents or reconstruction of the document.

CONTENTS

LIST OF FIGURES	ii
LIST OF TABLES.....	iv
PREFACE.....	v
1. INTRODUCTION	1
2. TECHNICAL DESIGN	6
2.1 VHF BODY-BORNE ANTENNA.....	6
2.2 HIGH-EFFICIENCY SWITCHING CIRCUIT.....	10
2.3 CONFIGURATION OF TRANSMITTING BODY-BORNE ANTENNA SYSTEM	13
2.4 TEXTILE CONDUCTOR REQUIREMENTS	16
2.5 TEXTILE CONDUCTOR CONSTRUCTION	16
2.6 ELECTRICAL EVALUATION OF CONDUCTIVE FIBERS	18
2.7 PERFORMANCE OF MULTI-CONDUCTOR STRIPS.....	19
2.8 TINSEL WIRE NARROW-WOVEN APPROACH	20
2.9 WATERPROOFING THE TEXTILE CONDUCTORS.....	21
2.10 WATERPROOFING AND STRAIN RELIEVING THE MODULE CONNECTIONS BY OVERMOLDING.....	24
3. HARDWARE DESCRIPTION	28
4. MEASURED RESULTS	33
4.1 EVALUATION.....	33
4.2 SIGNAL STRENGTH MEASUREMENTS	33
4.3 COMMUNICATION RANGE TESTS	39
4.4 VOICE QUALITY AND FREQUENCY-HOP PERFORMANCE.....	42
5. CONCLUSIONS AND RECOMMENDATIONS	43
LIST OF ACRONYMS AND ABBREVIATIONS	45

LIST OF FIGURES

<u>Figure</u>		<u>Page</u>
1.	Prototype Wearable Body-Borne Antenna/Radio.....	1
2.	VHF Proof-Of-Concept Antenna Circuit.....	2
3.	Rigid Square Crossed-Loop Antenna	3
4.	Textile Conductor for Body-Borne Antenna	4
5.	Overmolded Textile/Electronics Connection.....	4
6.	Nonfunctional Antenna Demonstrates Appearance of Final Product.....	5
7.	Ideal Radiation Pattern Produced by a Crossed Loop that is Independent of the Soldier’s Position.....	6
8.	WIPL-D Body-Borne Antenna Model (Air and Tissue Models).....	7
9.	Azimuth Patterns of Body-Borne Crossed-Loop in Air	8
10.	Azimuth Patterns of BodyBorne Crossed-Loop on Body.....	8
11.	Permissible Radiated Power from a Body-Borne Antenna using IEEE Guidelines	9
12.	The Basic Energy-Switching Scheme Produces a Trapezoidal Waveform that Very Closely Matches the Sinusoid so that the Generation of Spurious Noise is Minimized.....	13
13.	The Connection of Four Switching Circuits in Series Increases the Loop Drive Voltage.....	14
14.	Block Diagram of Body-Borne Transmitting Antenna.....	15
15.	Narrow-Woven uses Conductive Threads (Red) for Selected Warp Elements	17
16.	The Effect of Cleaning on Narrow-Wovens	19
17.	Frayed Aracon Fibers Short Conductors in Narrow-Woven	19
18.	Selected Narrow-Woven Conductive Textile using Tinsel Wire and Nylon Insulators.....	20
19.	Monolithic Plastic Coating Reduces Flexibility of Textile Conductor.....	21
20.	Waterproofing the Textile Conductor with a Laminated Film	22
21.	Overmold of PC Card Interface to Prototype Electronic Module.....	25
22.	Show-Through is Caused by Non-Centered Narrow-Woven in Mold	26
23.	Bend Modules and Short Textile Conductors Complicate Mold Design	26
24.	Nonfunctional FLC Antenna Demonstrates Final Product.....	28
25.	An Overmolded Antenna System on FLC Vest that can be Tested with Prototype Circuit Modules.....	29
26.	Open FLC with Covered Electronics.....	31
27.	Photo of Open FLC Identifying Electronic Components	32
28.	Signal Strength Measurement Test Range.....	33
29.	Photo of Signal Strength Measurement Range	34
30.	Spectrum Analyzer Measures Signal Strength	35
31.	Wood-Supported Loop on Test Range	35
32.	Measured Radiation Levels Agree Well with Predicted Values.....	35
33.	Wearable Antenna Supported by PVC Fixture.....	36
34.	Wearable Antenna Tested in Various Positions.....	37
35.	Radiation Level on Human Shows Small Variation with Wearer Orientation.....	38

LIST OF FIGURES (Continued)

<u>Figure</u>		<u>Page</u>
36.	Measured Improvement Factor of Individual Switching Module Demonstrates 10 Times Reduction in Prime Power Requirement.....	39
37.	Two Radio Operators Communicate Via Wearable Antennas	40
38.	Communication Range Testing.....	40
39.	Communication Range Contours when using Body-Borne Antenna Systems.....	41

LIST OF TABLES

<u>Table</u>		<u>Page</u>
1.	Waterproofing Trial 1 - Heat-Sealed Samples, Water Immersion, No Sewing.....	23
2.	Waterproofing Trial 2 - Heat-Sealed Samples, Water Immersion, Sewn Across the Narrow-Woven.....	23
3.	Waterproofing Trial 3 - Dip-Coated Samples, Water Immersion, Sewn Across the Narrow-Woven.....	24
4.	Weight Breakdowns of the Prototype Antenna Vests.....	30

PREFACE

The Fight Load Carrier VHF Body-Borne Antenna System was developed by BAE Systems, Greenlawn, NY, for the U.S. Army Soldier Systems Center, Natick, MA during the period September 1999 through July 2002 under Contract Number DAAD16-99-C-1047.

The purpose of the program was to develop the conductive textile for a wearable VHF antenna that uses electronic components in its design. The program developed methods of attaching, sealing and ruggedizing the connections between the textile conductives and the circuit modules. This is the final report for the program.

DEVELOPMENT OF A FIGHT LOAD CARRIER VHF BODY-BORNE ANTENNA SYSTEM

SECTION 1

INTRODUCTION

The purpose of this program was to develop the conductive textile technology for a wearable prototype of a VHF body-borne antenna. An active antenna system uses electronic circuits that are distributed throughout the antenna system. Another purpose of this program was to develop methods for attaching, sealing, and ruggedizing the connections between the textile conductors and the circuit modules. A prototype antenna is shown with a Single Channel Ground Airborne Radio System (SINCGARS) radio in Figure 1.



Figure 1. Prototype Wearable Body-Borne Antenna/Radio

The use of a body-borne antenna enables the soldier to conduct combat activities unrestrained by an external antenna. In addition, the conformal antenna provides no visual signature that identifies the radio operator. While the advantages of the body-borne antenna have been apparent for some time, traditional antenna technology has prevented a successful implementation at VHF and lower operating frequencies.

The enabling technology for development of the body-borne antenna was an invention at BAE Systems that improves the efficiency of an electrically-small transmitting antenna when operating over a large band of frequencies. The design of a body-borne antenna for the SINCGARS radio band (30 - 88 MHz) is only possible using this new antenna system because the efficiency of a traditional antenna is very low, resulting in either low radiated power or high

battery consumption. Traditional antennas exhibit low efficiency because the available dimensions that are suitable for a body-borne configuration are very small relative to the wavelengths in the VHF band.

Joe Merenda, an antenna engineer in BAE Systems Wheeler Laboratory, patented the new active transmitting antenna in 1995. The new antenna system uses nonlinear switching elements that are embedded in the radiating structure to increase the wideband efficiency. While practical constraints on switching components prevent the antenna from achieving 100% radiation efficiency, this new technique has demonstrated an improvement over a traditional antenna system of the same size by a factor of fifteen. That improvement is just enough to enable the body-borne antenna/radio to achieve communication range comparable with the standard 1-meter non body-borne antenna that is presently used.

The validity of the concept was demonstrated at the time of the invention by the development of a very low frequency, low power system. Subsequent IR&D developed the VHF theory of operation, design approach for the optical distribution network and the receiver operation.

In 1998 the Defense Advanced Research Project Agency (DARPA), under the management of the Communications Electronics Command (CECOM), funded BAE Systems to fabricate a prototype switching circuit that could prove the feasibility of this technique in the VHF band. The small scale antenna element and switching circuit shown in Figure 2 was completed in late 1999. A fifteen times efficiency improvement was demonstrated for this system when operated at radiating current levels that would be compatible with the final body-borne system.

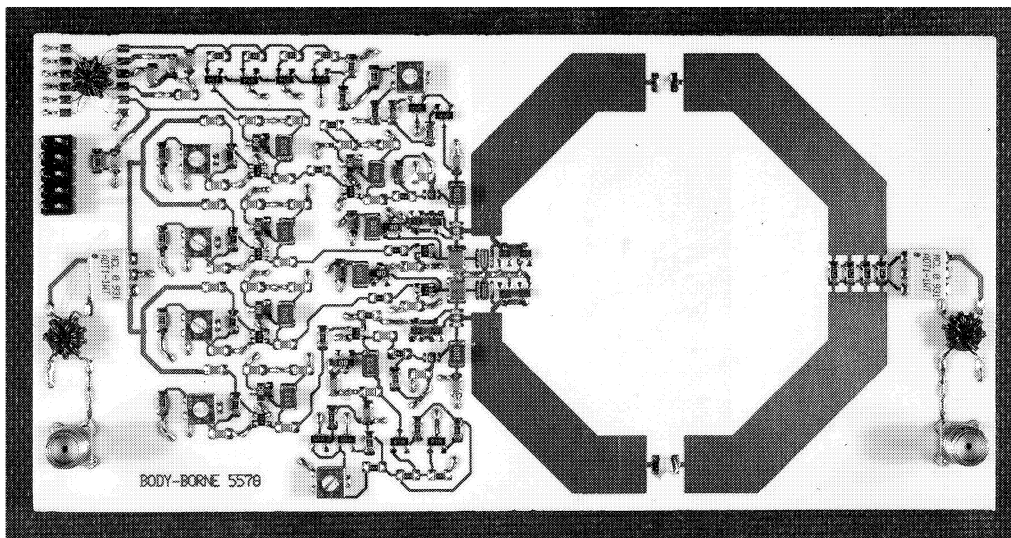

Figure 2. VHF Proof-Of-Concept Antenna Circuit

CECOM awarded BAE Systems a contract in 2000 under the Soldier Worn Antenna Technology (SWAT) program to fabricate the circuits for a full-size VHF transmitting antenna system. During the same period Natick Labs awarded this contract to the team of BAE Systems and

Foster-Miller Inc. for the development of the textile technology that could be used in the wearable implementation of this antenna system.

The circuit modules were designed under the SWAT program and a rigid antenna system was successfully demonstrated in the Summer of 2001. That antenna system is shown in Figure 3.

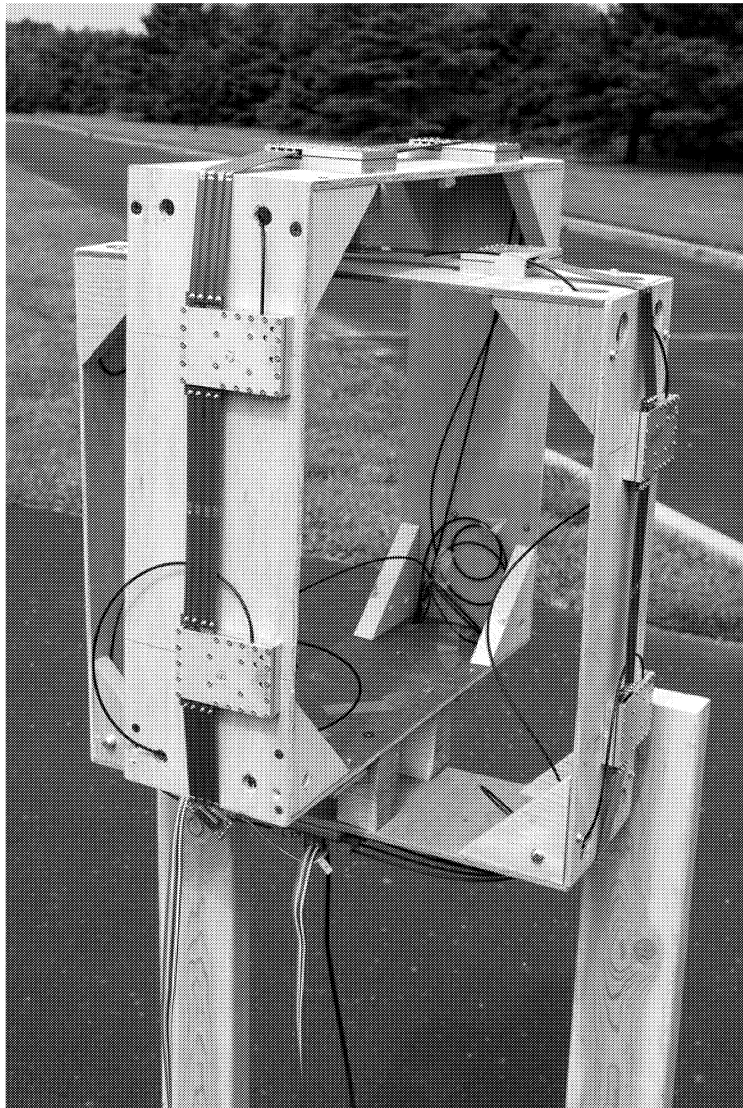

Figure 3. Rigid Square Crossed-Loop Antenna

During the same period Foster-Miller developed the textile conductor shown in Figure 4.

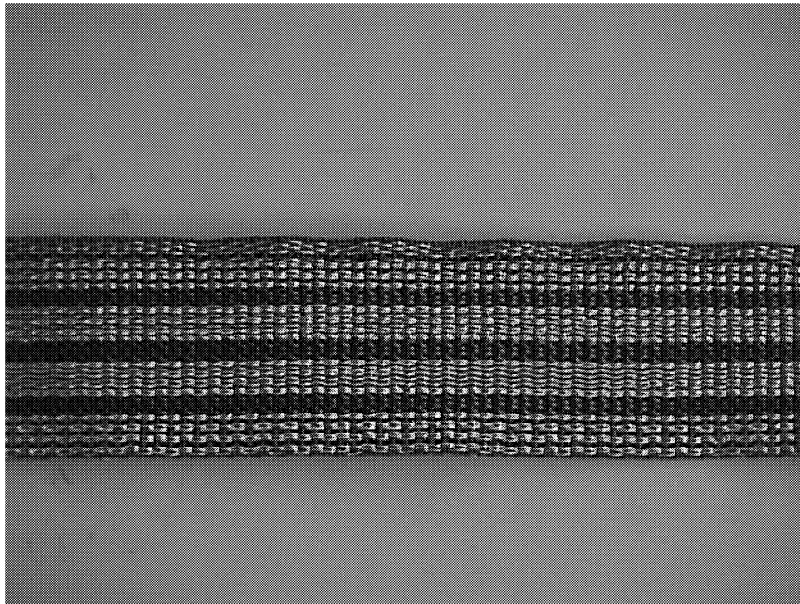

Figure 4. Textile Conductor for Body-Borne Antenna

Foster-Miller also developed an overmolded system that could be used to seal and strain relief the connections between the textile conductor and the electronic modules. A prototype overmold is shown in Figure 5.

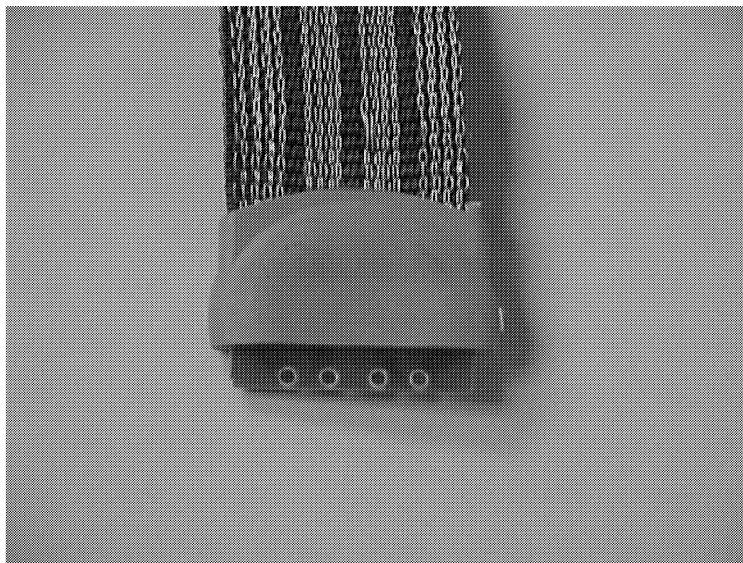

Figure 5. Overmolded Textile/Electronics Connection

Subsequent to the SWAT program, CECOM awarded another program to BAE Systems to integrate the electronic modules and textile conductors into two wearable antenna systems that could be field tested.

Those antenna systems (one shown in Figure 1) were successfully demonstrated in radio communication tests during the Spring of 2002. The wearable antenna/radio systems exhibited communication ranges that were comparable to those when using standard, external 1-meter antennas.

Foster-Miller has also optimized the module shape in terms of soldier comfort. An antenna has been constructed using dummy modules (Figure 6) to demonstrate the appearance of the final configuration. A subsequent program to miniaturize the electronics will enable fabrication of a functional version of that antenna.



Figure 6. Nonfunctional Antenna Demonstrates Appearance of Final Product

In the following sections the requirements, evolution, and testing of the textile conductor system are discussed. The overmold process and methods for water sealing of the flexible conductor system are also described. Some of the field tests of the prototype wearable antenna systems are presented. Finally, there is a discussion of the recommended tasks and technology investigations needed for bringing a reliable body-borne antenna system to production.

SECTION 2

TECHNICAL DESIGN

This section briefly discusses the design of the textile conductor for a wearable VHF body-borne antenna.

2.1 VHF BODY-BORNE ANTENNA

The requirements of the textile portion of the antenna system can be better understood by first presenting a brief explanation of the electrical operation of the antenna system.

The body-borne antenna uses a crossed-loop radiator configuration. The advantages of crossed-loop radiators for the VHF body-borne application include isotropic pattern coverage, immunity to body affects, better building penetration, greater radiation capability while adhering to the electromagnetic fields exposure limitations, and compatibility with the efficiency improving switching technique.

The crossed-loop configuration closely approximates the isotropic radiator, meaning equal radiation in all directions. In a practical sense that translates to constant communication range whether the soldier is standing, sitting, prone, or in any conceivable orientation. This can be more easily seen with the aid of Figure 7, which shows the individual patterns of a loop and the composite pattern when the power from the two loops is combined through a quadrature coupler. As a point of comparison, the commonly used whip antenna performs very poorly when horizontally oriented.

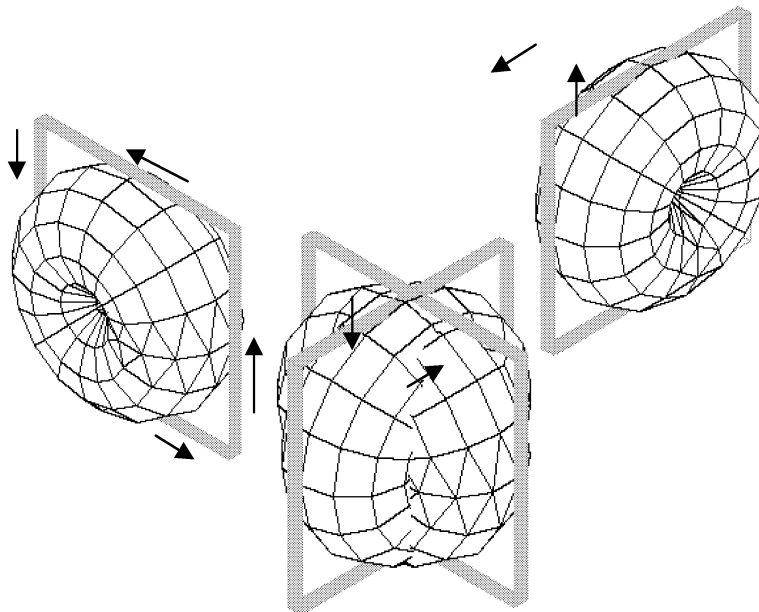

Figure 7. Ideal Radiation Pattern Produced by a Crossed Loop that is Independent of the Soldier's Position

The shape of the human torso does not permit the ideal crossed-configuration and the inside of the loop is filled with human tissue instead of air. The affects of those perturbations were modeled through the use of the WIPL-D antenna software, which can include complex dielectric structures. The approximate software model of the human torso with the radiating strips is shown in Figure 8.

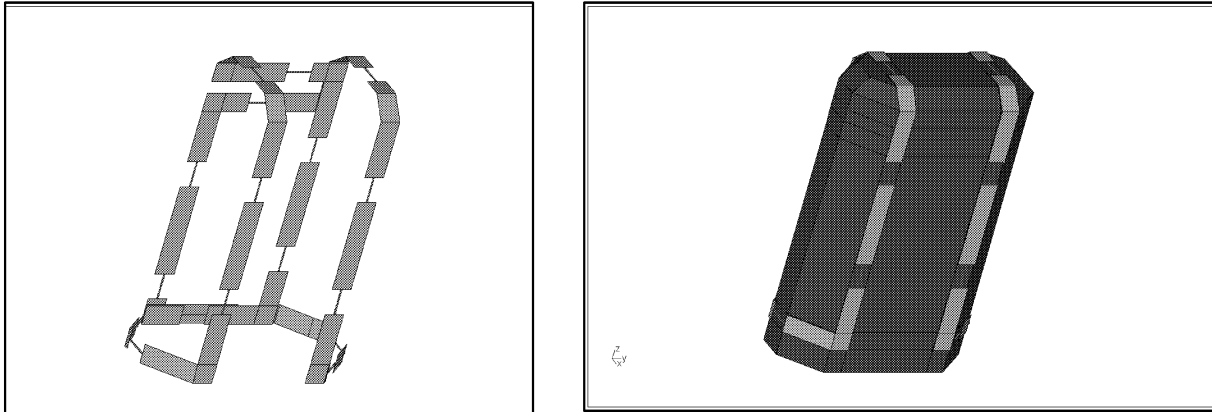

Figure 8. WIPL-D Body-Borne Antenna Model (Air and Tissue Models)

The blue strips are the radiating conductors. There are two loops that are each fed in eight places. The gaps in the conductors are where the switching modules are placed. The two loops are fed in quadrature relative to each other.

Some typical azimuth patterns are presented in Figures 9 and 10. Azimuth patterns are shown at three frequencies equally spaced across the SINCGARS band. The patterns represent signal strength versus azimuth direction with the soldier standing upright. The amplitudes in the plots do not represent absolute gain but are intended to show shape or the variation in dB.

The patterns in Figure 9 illustrate the affect of the non-ideal geometry in air. The patterns demonstrate relatively constant amplitude versus direction. The human body has been added in Figure 10. Human tissue has been modeled with a dielectric constant equal to 42 and a loss tangent equal to 2.5. While the patterns are degraded to a small extent, the signal amplitude is still relatively constant versus direction.

The near electromagnetic fields of electrically small loop antennas are primarily magnetic, which means that the antenna behaves like a lumped inductor. Since dielectrics or small metallic objects do not significantly affect inductors, antenna performance is relatively independent of the human body (lossy dielectric) or metallic weapons that would tend to de-tune or “short out” electric field-type radiators like the whip antenna.

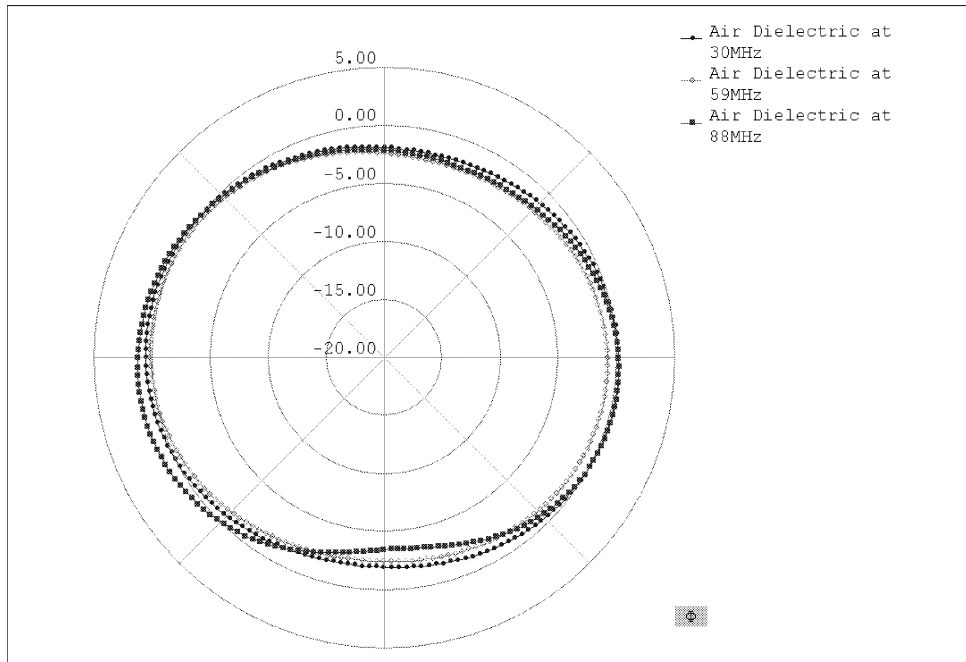

Figure 9. Azimuth Patterns of Body-Borne Crossed-Loop in Air

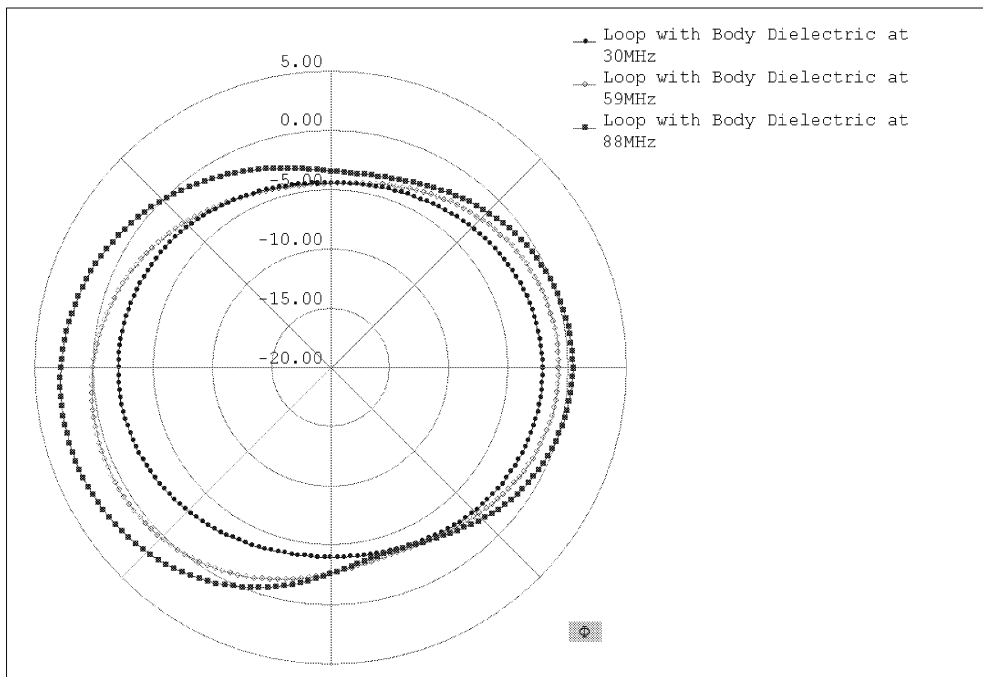

Figure 10. Azimuth Patterns of Body-Borne Crossed-Loop on Body

Another significant benefit of the small loop when operating at low frequencies is the amount of radiation that is possible while adhering to the safety limitations on human exposure to electromagnetic fields. The government standards are published by the IEEE¹. Those standards clearly state that the human body is more tolerant of magnetic fields than electric fields at low frequencies. The near fields for the small loop are primarily magnetic. Similarly, the near fields of an electric-field radiator (dipole) are electric. The magnetic field inside a loop is proportional to the current that flows in the loop. Hence, one can compute the maximum allowable current from safety considerations and convert that to radiated power by computing the radiation resistance of the small loop. We are designing the antenna system to radiate power levels that are consistent with the controlled exposure levels specified by the IEEE. Those exposure levels have been converted to radiated power for a 0.5-meter per side Merenda loop. Figure 11 presents the results of the conversion, representing the EIRP that can be expected from the Merenda antenna system designed under this program.

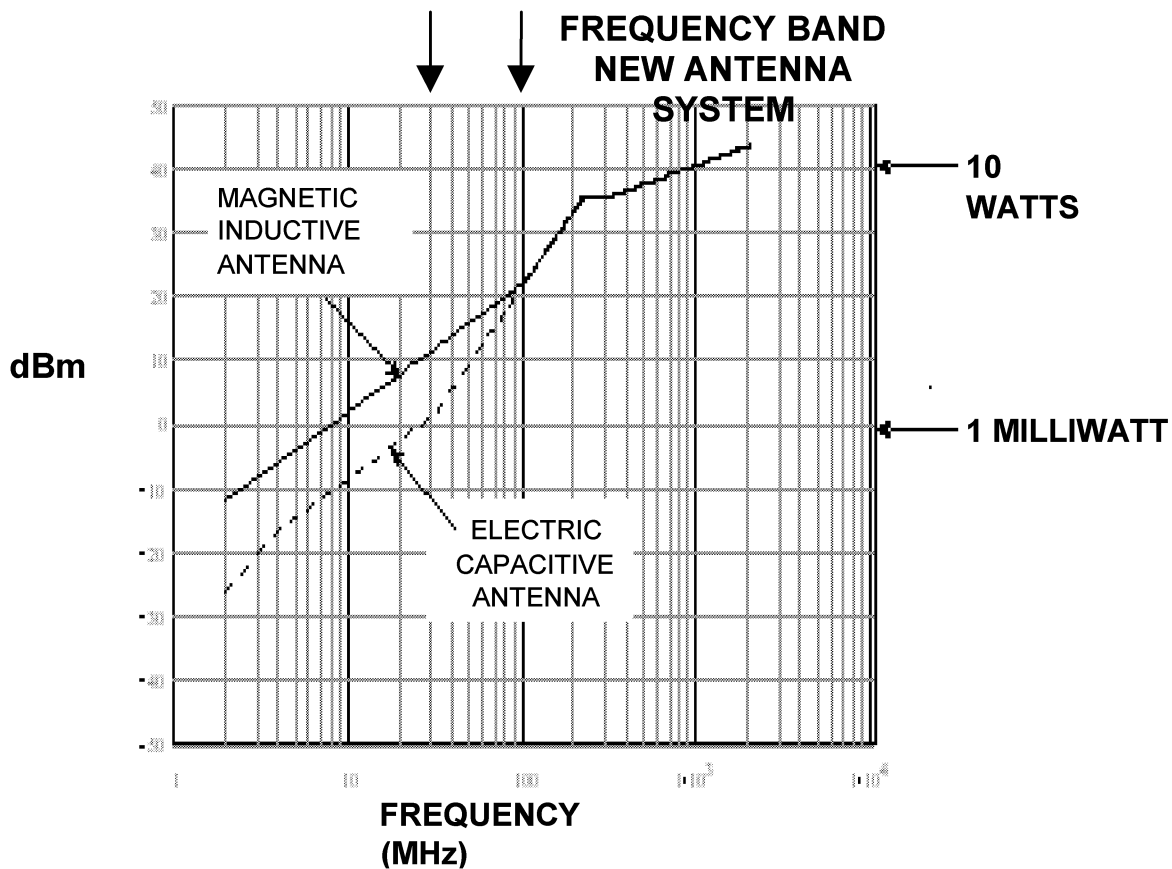

Figure 11. Permissible Radiated Power from a Body-Borne Antenna using IEEE Guidelines

¹ IEEE, "IEEE Standard for Safety levels with Respect to Human Exposure to Radio Frequency Electromagnetic Fields 3 kHz to 300 GHz", IEEE C95.1-1991 (revision of ANSI C95.1-1982); September 26, 1991

The calculations show that the antenna will radiate about 10 mW at 30 MHz and 100 mW at 88 MHz. Those levels are comparable to the actual radiation obtained from existing portable SINCGARS radios using external 1-meter tape antennas when one considers the actual radiation efficiency of the 1-meter antenna. One must also account for the poor pattern of the 1-meter tape antenna, which must be vertically oriented. Hence, the average communication range of systems using the body-borne antennas will approach or be approximately equal to existing radio systems.

Finally, simulations have shown that magnetic radiators (loops) perform 10 dB better than electric radiators at VHF or lower frequencies as one attempts to communicate from the outside to the inside of urban structures. Buildings built as a cage of steel beams tend to short out the electric field but enhance the magnetic component.

2.2 HIGH-EFFICIENCY SWITCHING CIRCUIT

A new approach to the synthesis of radiated energy, invented at BAE Systems, has resulted in a significant increase in radiation for a given amount of prime power or, conversely, a significant decrease in required battery power for a given amount of radiation. Since all soldier-embedded systems are powered by a portable energy source (e.g., batteries), any technique that increases the efficiency of energy conversion between the prime power source and radiation is of paramount significance. It leads directly to an extension in mission life and helps our troops retain information dominance on the battlefield.

A simple two-element circuit model can accurately characterize the small loop antenna. That circuit includes the inductance of the loop in series with a small radiation resistor. Power delivered to the radiation resistance represents the actual signal level converted to radiation. The “Q” of the circuit at any frequency is defined as the ratio of the reactance of the inductor to the resistance. Therefore, the Q of electrically-small antennas is very high.

Q is a useful parameter since it provides a way for bandwidth and efficiency of simple circuits to be evaluated. Higher Qs are generally associated with lower efficiency and narrower bandwidth. It is significant to note that the Qs of small antennas vary inversely with the cube of electrical size. Therefore, the performance of a small antenna rapidly degrades as its size is decreased. As an example, a loop 0.5 meter on a side (considered practical for integration in the soldier’s clothing) exhibits a Q of 16,000 at 15 MHz, whereas the Q is only about 2000 at 30 MHz. The smaller wavelength at 30 MHz and the cubic relationship cause the large variation.

Since the size of the human torso is small relative to the wavelengths in the VHF band, the Q of body-borne antennas intended for operation in that band are very high. The high Q generally leads to very poor antenna efficiency, especially when operating over a very large bandwidth, e.g., the 30- to 88-MHz SINCGARS band.

Narrowband implementations use a passive tuning (a matching circuit) to obtain high efficiency. This efficiency exists only over a narrow bandwidth. The bandwidth will be insufficient to operate with the SINCGARS radios. In order to widen the bandwidth one may either resistively load the antenna to lower the effective Q at the expense of efficiency, or one can adjust the tuning to obtain a relatively constant, but high reflection coefficient across the band.

A matching circuit offers little benefit when operating over the SINCGARS bandwidth. Therefore, a traditional system might use a linear amplifier whose output resistance is adjusted to be equal to the reactance of the untuned antenna. No matching circuit is used. A 3-dB attenuator is generally placed between the linear amplifier and untuned antenna in order to stabilize the VSWR at values less than 3:1. That is necessary to control amplifier distortion and efficiency. The overall efficiency that results from that configuration is equal to:

$$Eff = 1/3Q$$

where the efficiency defines the overall conversion efficiency of battery power to radiated power. It therefore includes the efficiency of the power amplifier and DC power conditioning circuits. It is an appropriate metric for comparing the traditional approach to the new one because the new approach converts DC energy directly to radiation. The Q in the equation is equal to the Q at each frequency. Hence, the efficiency will vary across a wide bandwidth, increasing at higher frequencies in the band.

The new approach uses an efficient, energy-switching circuit to improve the wideband efficiency of a small antenna. In theory this new approach can realize 100% radiation efficiency over an infinite band. Actual switching components limit the efficiency to lesser values; however, the efficiency is higher than that of the traditional wideband approach. The performance of the body-borne antenna using this approach averages about 10 dB more than that of the traditional circuit, defined by 1/3Q. That improvement translates to a factor of 10 reduction in transmitter battery consumption.

That ten times reduction in battery power is just enough to enable the realization of a practical body-borne antenna in the VHF band.

Conservation of energy flow between reactive elements of an electrical circuit may be used to explain the operation of the new and traditional antennas. The new approach achieves its properties by altering the flow of energy between the antenna reactance and an opposite reactance. A conventional antenna system is unable to alter the flow of energy from what would be expected from the natural resonance of the circuit components.

An over-simplistic explanation of how one might improve the efficiency of a small antenna states that nearly all the incident energy is reflected from a small antenna. That reflected energy is normally dissipated by the internal resistance of the generator. Efficiency can be improved by storing the reflected energy so that it can be delivered to the load at a later time rather than losing that energy through dissipation. While the principle is essentially correct, it offers no insight into how one might implement the storage function.

Reflection is a concept in linear analysis. The new concept employs nonlinear circuits that cannot be analyzed using linear theory. The concept can be explained by examining instantaneous energy storage in the time domain.

The reactive element of the high-Q antenna load stores electrical energy. That stored energy fluctuates as the current in an inductive element varies with time. The peak stored reactive energy is much greater than the energy delivered to the resistive part of the load during one cycle of the waveform. For a sinusoidal waveform the ratio of peak stored to dissipated energy per cycle is proportional to the Q of the load.

$$E_{peak-stored} = \left(\frac{Q}{2\pi} \right) E_{dissipated-load}$$

The stored reactive energy varies between the peak value and zero as the current or voltage in the load varies during the course of the waveform. Conservation of energy demands the accounting of all energy. When the peak reactive energy declines, the lost amount can only be accounted for in one of two ways. Either that energy is dissipated (converted to thermal energy) or maintained as stored electrical energy and transferred to another location. In many cases, e.g., without matching, the generator resistance dissipates the amount by which the peak stored energy is reduced.

In the case of a sinusoidal waveform, there are two peaks in the stored energy during each cycle and hence, that peak energy will be dissipated twice during each period of the waveform. Power is defined by the rate of energy dissipation. Therefore, conservation of energy establishes a limit on the minimum amount of power that must be dissipated by the internal resistance of the generator in the wideband case without reactive tuning. It also establishes an upper bound to the efficiency of the antenna, which can be approximated by the ratio of power delivered to the resistive part of the load to that dissipated by the generator.

When one uses reactive tuning to impedance match the antenna, the efficiency improves because the generator no longer dissipates the peak reactive energy generated in the load. Conservation of energy is not violated since that energy is transferred to the tuning reactance during periods when the load reactance energy is small. The energy is then available for reuse when the waveform demands that the load reactive energy again cycle to a large value. It is not necessary for the prime power source to supply the energy for each peak interval, since that peak energy can cycle back-and-forth between the load and tuning reactances. The prime source must only supply enough energy during the steady state to replenish that used by the real part of the load, which implies 100% efficiency.

The critical conclusion is that high efficiency is only possible if an alternate means of energy storage is provided during periods when the reactive energy in the load passes through or near zero. That alternate energy storage is provided when using reactive tuning; however, the drawback is that the natural electric forces only enable the energy to cycle between the two reactances in an efficient manner at one frequency. That fact results in the narrowband nature of highly efficient, passive impedance matching.

If it were possible to transfer energy between the load reactance and another storage element in an arbitrary manner without loss, it would be possible to achieve high efficiency over a wide band.

The new approach places an energy switching circuit between the antenna and a storage reactance of the opposite sense. The storage reactance need not resonate with the antenna; in fact, the natural resonance of the L-C should be well below the lowest operating frequency, greatly simplifying control of the circuit. The switching circuit enables energy to be transferred between the antenna and storage reactance in an arbitrary manner, allowing synthesis of wideband waveforms.

The basic energy switching circuit is demonstrated in the upper portion of Figure 12. Ideal switches dissipate no energy and allow piecewise-linear synthesis of the antenna waveform, either by allowing energy flow between the inductor and capacitor or by periodic freezing of the stored inductor energy. Switch operation during one possible simple algorithm for synthesis of a high-frequency sinusoid is demonstrated in the lower portion of Figure 12.

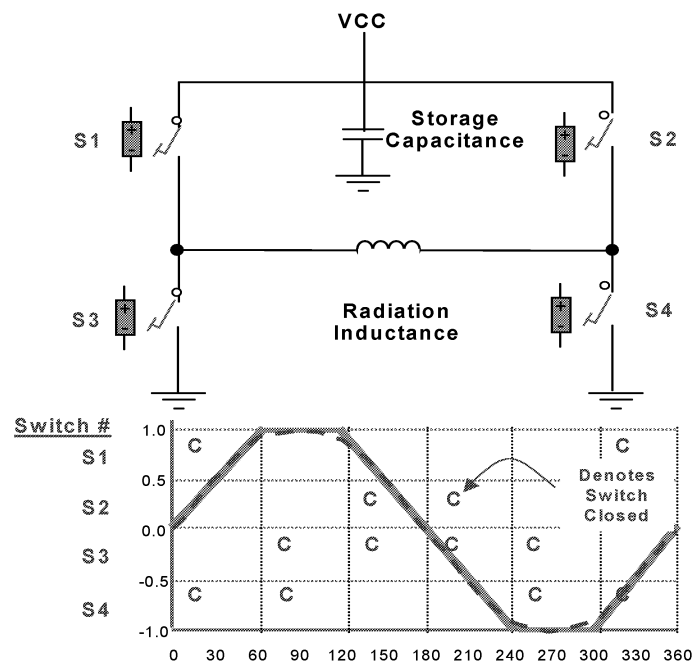

Figure 12. The Basic Energy-Switching Scheme Produces a Trapezoidal Waveform that Very Closely Matches the Sinusoid so that the Generation of Spurious Noise is Minimized

2.3 CONFIGURATION OF TRANSMITTING BODY-BORNE ANTENNA SYSTEM

The switching circuit shown in Figure 12 is used to efficiently synthesize the radiating currents on the loop conductors. The switch component parameters and the performance is determined by the radiating current. The maximum allowable loop current produces a magnetic field inside the loop that just equals the limitation on electromagnetic exposure.

The magnetic field limitations correspond to a loop current that decreases linearly with frequency. For a round, single-turn loop with a circumference equal to 1.7 meters (size compatible with installation conformal to human torso) the maximum peak current is 0.5 amps at 30 MHz. The inverse relationship with frequency leads to a maximum current equal to 0.15 amps at 100 MHz.

The loop behaves like a lumped inductor. Hence, its impedance increases linearly with frequency. Both relationships are fortuitous since the imposition of a constant voltage versus frequency will lead to a current that declines in the right manner. Therefore, a constant voltage can be maintained on the storage capacitor in Figure 12 and the radiating fields will just equal the maximum exposure limitations at all frequencies.

The voltage can be computed from the desired current and the loop impedance. The voltage is about 100 volts peak. If that voltage is maintained on the storage capacitor, the magnetic fields will exactly meet the exposure limitations at all frequencies in the band.

The performance, or radiation system efficiency improvement factor, depends on the parameters of the switching devices. Those parameters include the switch resistance, capacitance and transition time. In the VHF band the only devices that will perform are GaAs FETs. Unfortunately, the breakdown voltage of GasAs is relatively low and circuit operation is limited to about 12 Volts peak. The desired voltage is achieved by connecting eight switching circuits in series around the loop. A similar implementation with four circuits is illustrated in Figure 13.

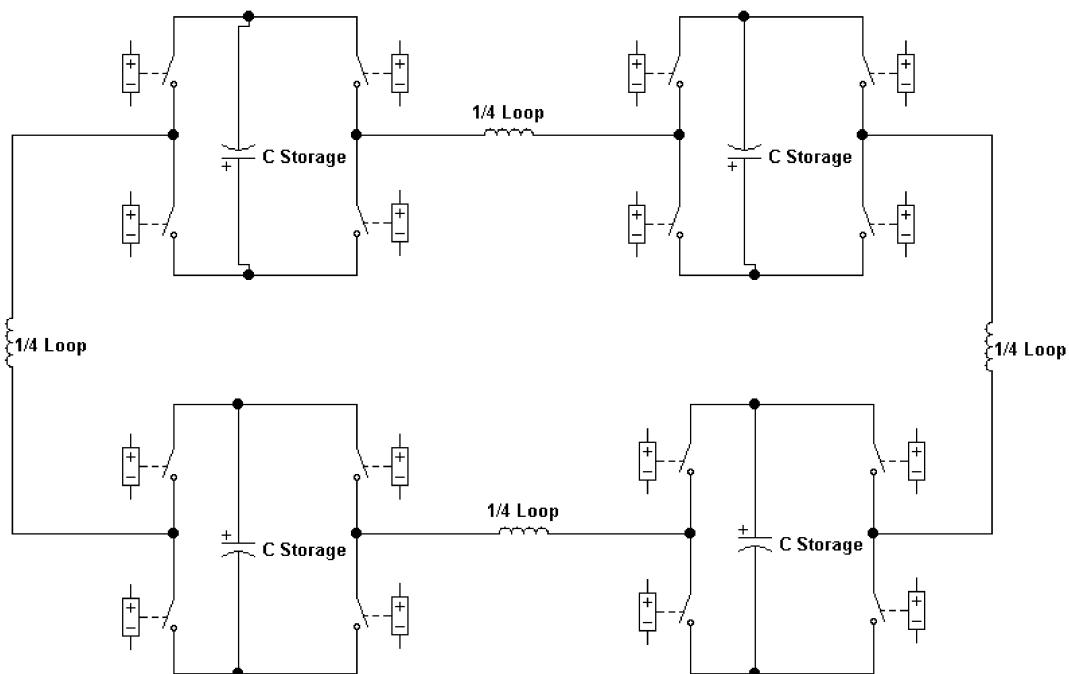

Figure 13. The Connection of Four Switching Circuits in Series Increases the Loop Drive Voltage

The segmented approach has two other advantages. The loop approaches one-half wavelength in circumference at about 80 MHz. It passes through a resonance that changes the terminal impedance from inductive to capacitive. Since the antenna and storage reactance must be of opposite sense, operation requires that the loop remain inductive across the band. Achieving the desired exposure-limited radiation level with constant voltage drive also dictates that the antenna

behaves as a lumped inductor. Therefore, the circuit cannot work into that varying impedance type. Similarly, the distributed affect associated with the half wavelength cause loop currents to vary around the loop. The varying current alters the radiation pattern characteristic.

Both problems are solved by use of the segmented loop. If the modules are driven in phase, the currents are forced to be equal all around the loop. That also drives the resonance up in frequency by a factor of eight – well out of the band of interest. The first resonance then occurs when each segment approaches one-half wavelength. Thus, the loop behaves as a lumped inductor across the entire band of interest. When the antenna behaves as a lumped inductor, immunity from body affects is also maintained.

The only complication when using the segmented approach is feeding control signals and DC power to each of the switching modules. Wired connections will interfere with the loop radiation.

The implementation shown in Figure 14 overcomes the problem. The control signals are fed optically to the modules. The plastic fiber-optic cable is transparent to the VHF radiation. DC is routed to the modules by sharing the loop radiating conductors. Each conductor consists of four parallel strips. The strips act as one at VHF because they are interconnected with large capacitors at each end. Three DC voltages and ground are routed around the loop and coupled to each module through RF chokes.

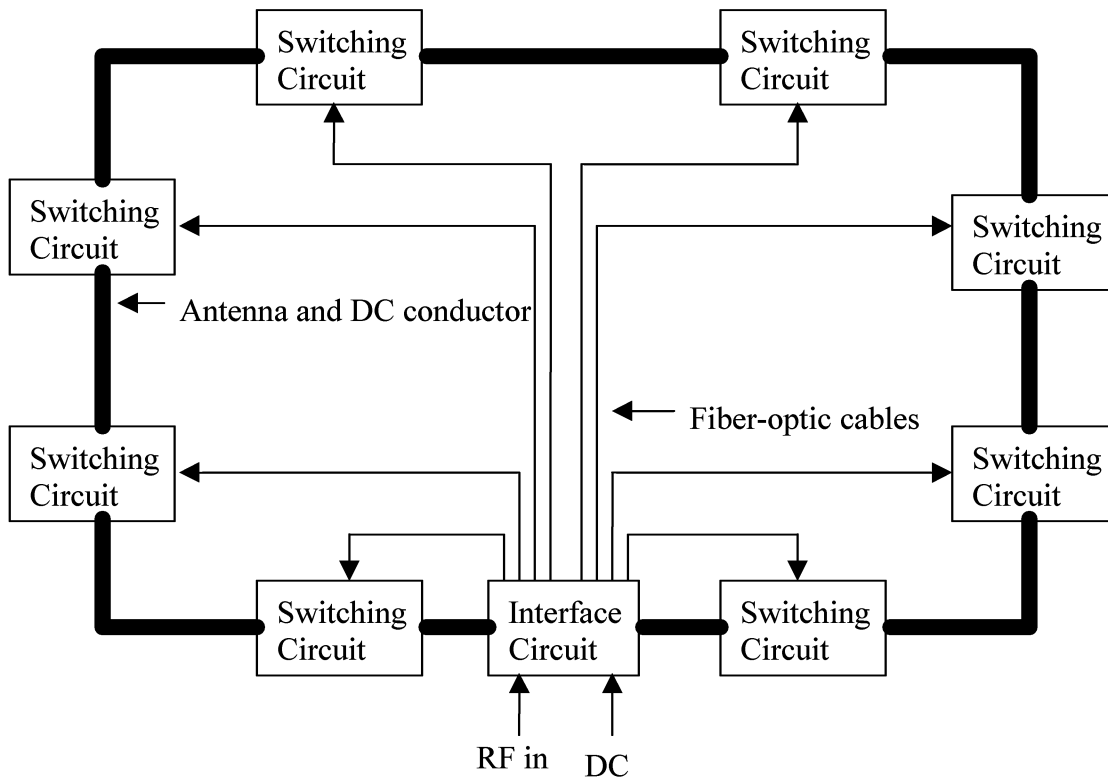

Figure 14. Block Diagram of Body-Borne Transmitting Antenna

A low power replica of the desired radiation waveform is fed to each module. The analog radio output is fed to an interface module where the low level output is modulated on an optical carrier for each module. Equal length optical cables are routed to each module to insure in-phase or equal currents around the loop. The interface module also connects to an external power supply. The supply voltages are coupled to the four-strip radiating conductor through chokes. In that way radiating currents are not conducted onto the power wires.

Two of these loop systems are included in each body-borne antenna. The radio output is split into two equal signals by an external quadrature coupler. The two outputs that differ in phase by 90 degrees are fed to the two loops.

2.4 TEXTILE CONDUCTOR REQUIREMENTS

The heavy lines that interconnect the switching circuits in Figure 14 are the radiating conductors. A body-borne implementation requires a flexible textile construction. In addition, the fiber-optic cables must be incorporated in the wearable apparatus.

Those radiating conductors, which consist of four isolated parallel strips, must meet electrical requirements while subjected to mechanical stresses and harsh environments both in the operating and non-operating mode.

The RF performance will not be impacted as long as the total loop resistance is less than about 3 ohms. The RF conductivity assumes that the four parallel strips that form the composite antenna conductor carry equal RF currents. The total DC resistance around the loop of each of the four narrow strips should be less than 1 ohm.

While the four strips carry equal RF current and could be implemented with a single wide conductor, the shared DC power function that is used for routing three voltages and ground require the use of four isolated strips. The integrity of the electrical isolation must be maintained under all operating and nonoperating conditions.

These electrical properties must be guaranteed after thousands of iterations where the conductors are exposed to severe flexing. Similarly, the conductors may experience harsh abrasion and exposure to heavy moisture both during operation and while cleaned.

A reliable method that can withstand the flexure and moisture must be developed for attaching the conductors to the circuit modules. The attachment method must provide strain relief and guarantee that no moisture will enter the circuit modules.

2.5 TEXTILE CONDUCTOR CONSTRUCTION

Traditional textile construction using thin fibers in a woven or braided configuration offers flexibility, comfort, and ruggedness. Those characteristics are important to the development of the body-borne antenna.

The thin fibers must be conductive. Several options exist on the market, ranging from simple metal plating on standard fibers to fibers that are 100 percent metal. In this program, two fibers were found to meet the conductivity and inductance requirements. The first was tinsel wire. The second alternative was an aramid fiber that is coated with a conductive material.

The design of the textile conductors had to take into account many requirements, including:

- Ruggedness
- Proper impedance
- Flexibility

Ruggedness requires good abrasion resistance for the entire textile, but especially for the conductive fibers. Conductive-coated fibers will remain conductive only as long as the coating remains in tact. Tinsel wire, which is composed by wrapping two metallized mylar foils around a nylon core, will lose its conductivity if the foils are damaged too extensively.

Two methods were considered for forming the textile. The narrow-woven approach uses a weave in which some of the warp or longitudinal threads are conductive (Figure 15). Since the transverse or weft threads extend across the width of the narrow-woven, they must be nonconductive in this design, which requires four isolated conducting strips.

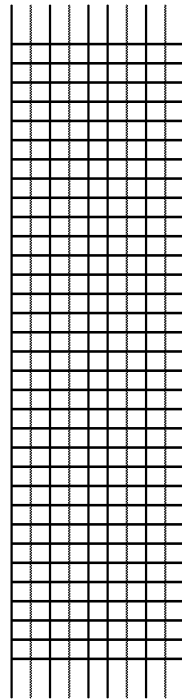

Figure 15. Narrow-Woven uses Conductive Threads (Red) for Selected Warp Elements

The second approach uses a braided structure. The braid uses bias and axial threads. Again, conductive and nonconductive threads may be combined to form a structure with four parallel, but isolated conductive strips in the axial positions. The number of bobbins that are used in the braided structure may control the width of the conductive portions.

Both methods of fabrication are compatible with the integration of fiber-optic cables. Both the woven and braided fabrics can be formed around the straight, plastic FO cable, thereby embedding the cable.

2.6 ELECTRICAL EVALUATION OF CONDUCTIVE FIBERS

The inductance requirement of the conductive textile will be acceptable as long as the total width of the conductive portion is approximately equal to 1 inch. No separate inductance measurements were made to confirm this fact. However, in subsequent system tests, antenna systems that used textile conductors radiated the same signal levels, or exhibited the same efficiency, as antenna systems that used rigid copper conductors.

The RF resistance of conductive fabrics was evaluated through Q measurements. The Q measurement technique is the industry-wide standard method for determining the RF resistance or loss of conductive materials. In this method an extremely narrowband filter or resonator is constructed. At VHF the resonator is generally coaxial. Loss is magnified in the narrowband resonator. Hence, this is an effective method for evaluating the loss very accurately.

Three potential conductive threads were identified and evaluated. Those include silver-coated copper tinsel wire, metal coated Aramid fibers (AraconTM), and silver coated nylon (X-static products).

In the Q measurements the resistance of the tinsel wire and the Aracon product manufactured by DuPont was compared to that of pure copper wire. Based on the Q measurements it was found that the surface resistance of both the tinsel wire and Aracon fibers was within a factor of three of pure copper.

The RF resistance of a pure copper strip easily meets the requirements. The RF resistance of a 1-inch wide loop around its entire 1.7 meter periphery is approximately equal to 0.1 ohms at 88 MHz. Therefore, the resistance of textile conductors that are 1-inch wide will be less than 0.3-ohms, a factor of ten better than the 3 ohm requirement. Therefore, both the tinsel wire and Aracon are viable textile materials.

The DC resistance of both materials meet the DC requirements.

Tests were also conducted to evaluate the resistance degradation as the conductive textiles were exposed to washing and dry cleaning cycles. The resistance of test samples as a function of the number of cleaning cycles is plotted in Figure 16. The materials are stable after many cleaning cycles.

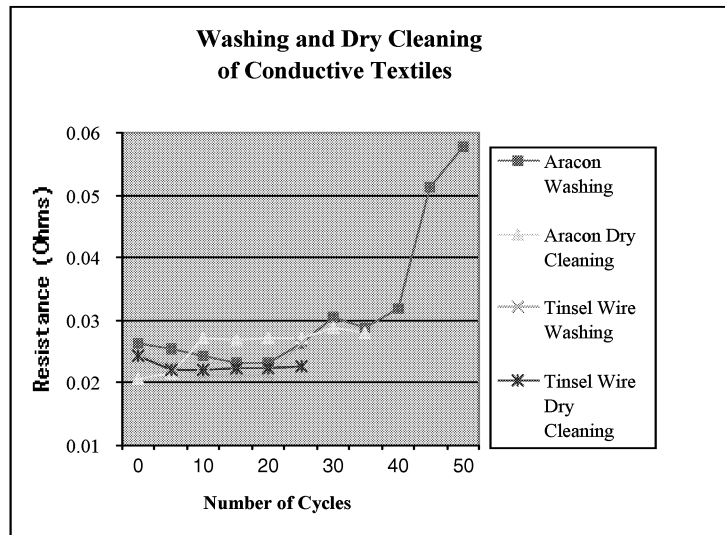

Figure 16. The Effect of Cleaning on Narrow-Wovens

2.7 PERFORMANCE OF MULTI-CONDUCTOR STRIPS

It was found that the DC isolation between strips in the Aracon design was very poor. In many instances, there were DC short circuits between adjacent strips. The problem was apparent as viewed through a microscope (Figure 17).

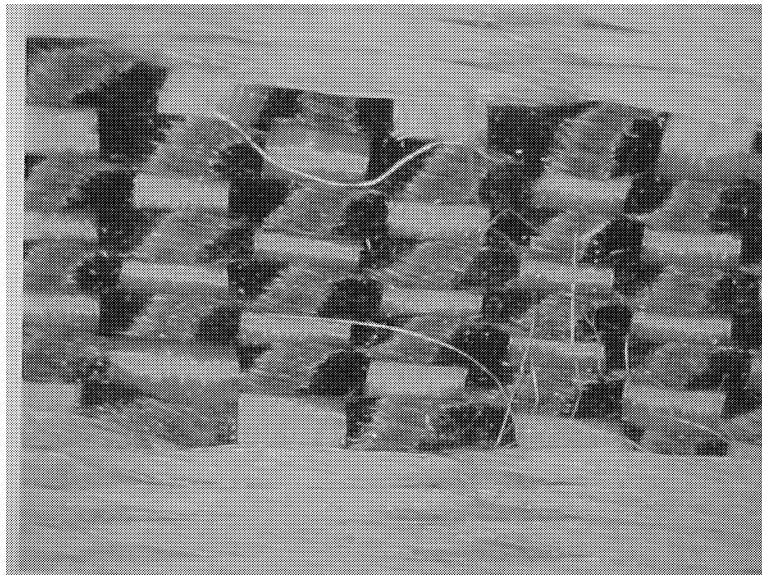

Figure 17. Frayed Aracon Fibers Short Conductors in Narrow-Woven

There were frayed fibers from the Aracon yarn used to manufacture the structure. When those fibers came in contact with fibers from an adjacent conductive strip a short circuit occurred.

It was concluded that the fraying was caused by the loom and could possibly be corrected with some loom modifications. A post-process was demonstrated to fix the short-circuiting.

2.8 TINSEL WIRE NARROW-WOVEN APPROACH

The selected tinsel-wire narrow-woven is shown in Figure 18. This approach met all the electrical requirements and was the lowest cost. It exhibited adequate flexibility for the body-borne application.

The narrow-woven approach showed superior abrasion resistance to the braided approach using tinsel wires, and was therefore preferred.

As can be seen in the photo many tinsel wires are used as warp threads in each conductive strip. Some of the warp threads in each conductor, all of the warp threads in the insulator portions, all of the transverse or weft threads, and the selvage or edge finish are nylon yarns.

Four 0.5-millimeter diameter fiber-optic cables are embedded in each of the two center conductors. The fibers are completely covered by the narrow-woven and cannot be seen in the photo.

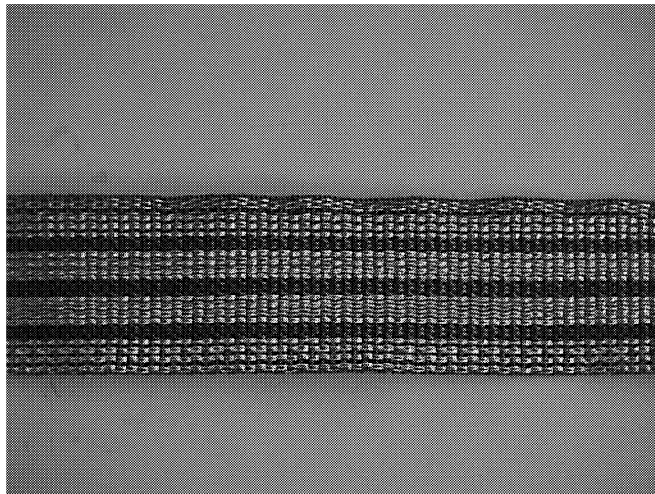

Figure 18. Selected Narrow-Woven Conductive Textile using Tinsel Wire and Nylon Insulators

2.9 WATERPROOFING THE TEXTILE CONDUCTORS

Antenna waterproofing will be critical when this system is fielded. The presence of moisture could create a conductive path between the parallel conductors, significantly impacting the DC distribution. In an extreme case the entire flight load carrier could become partially conductive due to the moisture. In that case electrical contact between the carrier and the antenna conductors could degrade the antenna RF performance. Therefore, it is extremely important to provide a moisture-proof nonconductive barrier that encapsulates the antenna conductors.

We discovered in this program that the waterproofing task is not as simple as had been originally anticipated. Monolithic plastic coatings are too thick and reduce the flexibility of the textile to the point that they no longer can be considered wearable as shown in Figure 19.

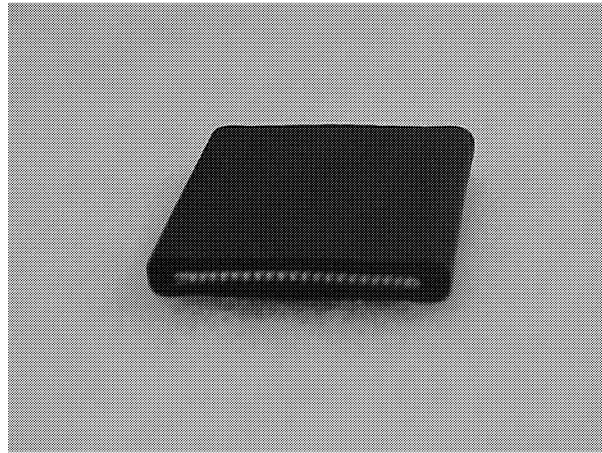

Figure 19. Monolithic Plastic Coating Reduces Flexibility of Textile Conductor

Two methods for waterproofing narrow-woven four-channel antenna bus were tested in this program. The first consisted of wrapping the sample with a heat sealing plastic sleeve (Figure 20), and then putting it through the required heating process to achieve a seal. The second method was dip coating the antenna bus in a 25% weight sample of Pearlthane 126-K thermoplastic urethane dissolved in tetrahydrofuran (THF). This process consisted of dipping the antenna bus into the solution, and allowing the solvent to evaporate. A third method, spray coating, was also tried, but because this method yielded such poor results, it warranted no further investigation.

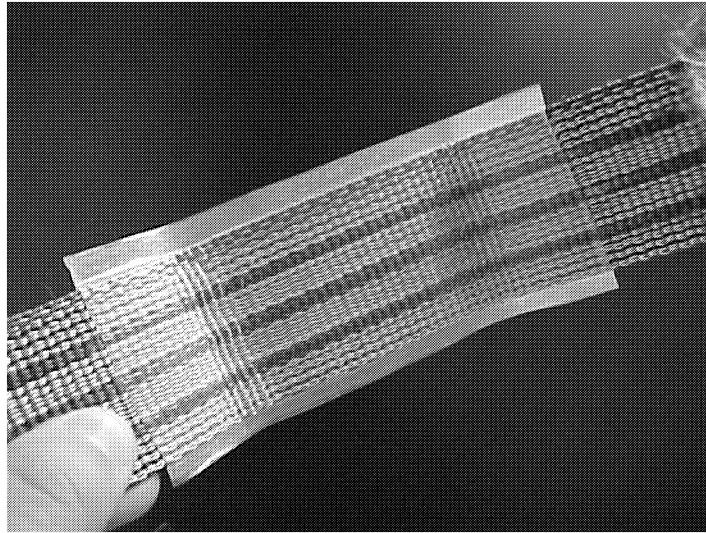

Figure 20. Waterproofing the Textile Conductor with a Laminated Film

Four samples of two lengths, 4.5 inches and 6 inches, were prepared using the heat sealing method. The open loop and closed loop resistances of the four samples were measured using a four-point probe on an LCR meter. Closed loop resistances refer to having all four probes on one channel of the bus. Open loop resistances refer to having two probes on both of the outermost channels, so that the measurement is being taken across the whole width of narrow-woven. The samples were then placed in a salt-water bath at room temperature for 30 minutes. After 30 minutes, the samples were removed, and the measurements were repeated. The results are given in Table 1.

In the construction of the wearable antenna in the FLC vest, the preferred method for attachment is to sew the antenna bus pieces directly to the vest. Due to the potential problems sewing could introduce to the waterproofing, the decision was made to retest the samples with a stitch across the width of the narrow-woven. After having the stitch sewn across them, the four samples were tested in the same method as described above. Table 2 summarizes the results of this test.

Table 1. Waterproofing Trial 1 - Heat-Sealed Samples, Water Immersion, No Sewing

Sample	Sample Length (Inches)	Resistance Before Water Treatment: Closed Circuit/ Open Circuit (Ohms)	Resistance After 30 Minutes Salt Water Treatment: Closed Circuit/ Open Circuit (Ohms)
1	4.5	0.016/100M	0.016/89M
2	4.5	0.010/90M	0.016/41M
3	6	0.016/65M	0.022/73M
4	6	0.016/65M	0.016/65M
NOTE			
The open circuit values were taken at the lowest frequency that registered resistance. The closed circuit value is a rough average at median frequencies. The samples exhibit frequency dependency such that in the open circuit measurement, resistances are inversely proportional to frequency, while the closed circuit resistance values are directly proportional to frequency.			

Table 2. Waterproofing Trial 2 - Heat-Sealed Samples, Water Immersion, Sewn Across the Narrow-Woven

Sample	Sample Length (Inches)	Resistance Before Water Treatment with Stitch Across Narrow-Woven: Closed Circuit/Open Circuit (Ohms)	Resistance After 30 Minutes Salt Water Treatment with Stitch Across Narrow-Woven: Closed Circuit/Open Circuit (Ohms)
1	4.5	0.0138/158.247k	0.0151/91.62
2	4.5	0.0159/140.842k	0.0185/100.583
3	6	0.0161/127.858k	0.0249/105.371
4	6	0.0269/97.374k	0.0254/129.371
NOTE			
The open circuit values were taken at the lowest frequency that registered resistance. The closed circuit value is a rough average at median frequencies. The samples exhibit frequency dependency such that in the open circuit measurement, resistances are inversely proportional to frequency, while the closed circuit resistance values are directly proportional to frequency.			

After the heat-sealing samples were measured, a sample was prepared using the dip-coating method described above and allowed to dry completely. A stitch was then sewn across the dip-coated sample, identical to the heat-sealing samples. The same measurements were taken with the dip-coated sample as described above, and the results are presented in Table 3.

**Table 3. Waterproofing Trial 3 - Dip-Coated Samples,
Water Immersion, Sewn Across the Narrow-Woven**

Sample	Sample Length (Inches)	Resistance Before Water Treatment with Stitch Across Narrow-Woven: Closed Circuit/Open Circuit (Ohms)	Resistance After 30 Minutes Salt Water Treatment with Stitch Across Narrow-Woven: Closed Circuit/Open Circuit (Ohms)
1	4.5	0.006/322.759k	0.0139/1.865k
NOTE			
The dip-coated sample was measured prior to sewing, and showed the same level of waterproofing as the heat-sealed samples.			

While both methods for waterproofing gave results that were satisfactory, a difference in performance can clearly be seen in the sewing trials. Because the heat-sealing method only has superficial attachment to the narrow-woven, when the stitch is sewn across the narrow-woven, the needle holes allow for water to wick all the way into the nylon. The dip-coated sample, however, has a more intimate coating with the nylon, so the effect of the needle holes is minimized.

Another observation is that the process of sewing itself has affected the resistivity of the narrow-woven. The sewing path, however, is the "worst case scenario", sewing across the width of the narrow-woven and puncturing the conductive stripes. When we sew the antenna into the garment, we sew along the length of the narrow-woven in the insulating channels. Therefore, we do not expect that the sewing process is affecting the resistivity of the narrow-woven.

From this information, we have selected the dip coating as the waterproofing method for this program. This area requires further investigation, however, before the antenna can be truly considered waterproof, rather than merely water resistant. Foster-Miller is continuing to work on this area internally. We have sent samples of narrow-woven textiles to several experts to perform trials upon. The experts do seem to agree that waterproofing our narrow-woven is not a simple procedure, which correlates with our prior experiences. Fortunately, the experts do feel that a process that will work can be developed.

2.10 WATERPROOFING AND STRAIN RELIEVING THE MODULE CONNECTIONS BY OVERMOLDING

The narrow-woven in the antenna loop must connect to the antenna modules. Electrical connections are made by soldering, and the data is conveyed via fiber optics, but a robust physical connection is also required. In addition, the modules and the connections require waterproofing. Our approach to creating a rugged and waterproof physical connection was to overmold the modules with an injection molded cover that bonded to the narrow-woven as shown in Figure 21. The shape of the overmold could be designed to maximize the comfort of the modules against the body.

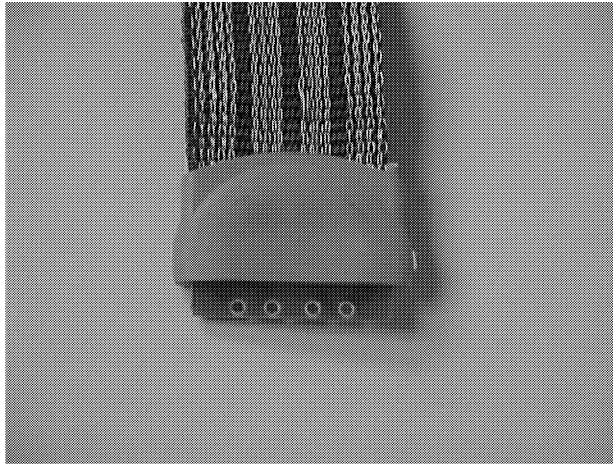

Figure 21. Overmold of PC Card Interface to Prototype Electronic Module

The overmolding was performed by Plastics One (Roanoke, VA). Plastics One designed and cut the molds, then injection molded the overmolds onto the antenna components. We required three molds: bend module, card-edge module, and dummy module. The bend module was used in both the functional and nonfunctional vests. The card-edge module was used in the functional vest only, and the dummy module was used in the nonfunctional vest only.

The first task was to select a plastic material for the overmold. It was discovered that nylon was the only material that would adhere to the nylon fabric in the narrow-woven. Other plastics could not provide a reliable moisture seal due to poor adhesion.

We encountered many problems in this portion of the effort. The technical challenges of overmolding on a textile was greater than expected. These obstacles included:

- a. Finding a Good Shut-Off System. In injection molding, the mold must close completely and withstand internal pressure to hold the molten plastic inside the mold, rather than shooting out the seam lines. In overmolding, the fact that a foreign object must be accommodated and given an exit from the mold increases the challenge. A textile in particular is difficult to close around because it is a rough surface and a flexible material. Plastics One had to perform a series of studies to identify a shut-off material that was able to conform to the textile and withstand the thermal stress of the molten nylon.
- b. Keeping the Textile Centered Within the Overmold. Because the narrow-woven is flexible, it would yield to the flow of the molten nylon. This movement would cause it to be pushed against the side of the mold, resulting in show-through (Figure 22). The solution to this problem was to build in holding pins into the mold to keep the textile centered. While this solution vastly improved the cosmetics of the overmold, the waterproofness of the overmold must be tested since little channels are left open with this technique.

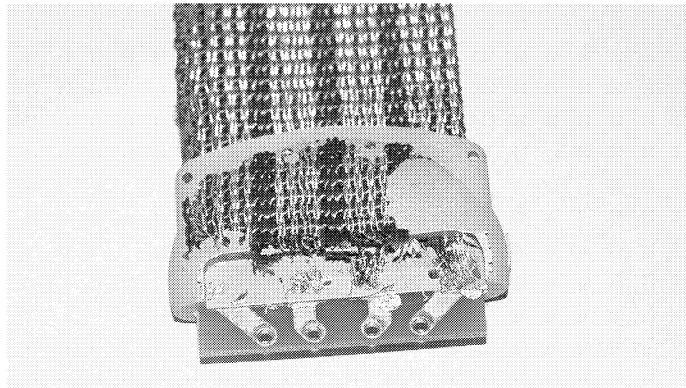

Figure 22. Show-Through is Caused by Non-Centered Narrow-Woven in Mold

- c. Thermal Robustness of the Solder and the Fiber Optics. The narrow-woven is made primarily from nylon. Our tests showed that nylon overmolding was the best in terms of adhesion to the narrow-woven. Other materials peeled off readily. Unfortunately, nylon's processing temperature is very high - approximately 575°F. This temperature caused the solder to reflow and melted the fiber optics completely. We would like to redesign the narrow-woven to use a different fiber, allowing us to use a lower melting point polymer for the overmold. This redesign will allow us to use standard solder and will allow the fiber optics to be overmolded.
- d. Logistical Issues with Fitting the Loop Into the Mold. Most overmolding is performed over simple, straight parts. Our bend modules were made to turn 90 degrees, and all of our pieces had a top and a bottom that had to be kept consistent throughout the loop (Figure 23). Plastics One had not fully comprehended this aspect of the task, and made the mold bolt holes in places where our narrow-woven would often be in the way. Some minor changes to the mold corrected this problem. In the future, a face-to-face kick-off meeting with the Plastics One mold designer is recommended.

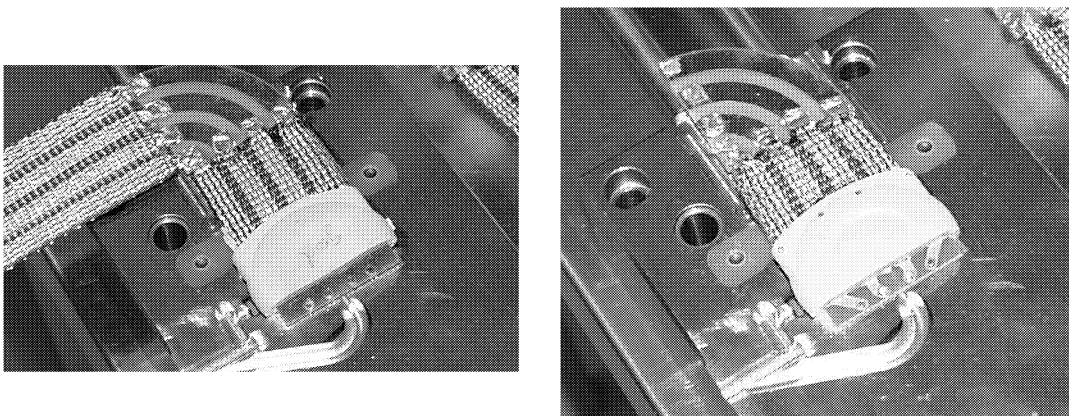

Figure 23. Bend Modules and Short Textile Conductors Complicate Mold Design

In the end, we did receive all the overmolded loop parts we required. Some showthrough is still occurring, but at much lower rates. The waterproofness of the overmolded parts has not been tested.

SECTION 3

HARDWARE DESCRIPTION

Under this program a total of two Fight Load Carrier (FLC) vests were modified to house antenna loops. One of those vests included textile conductors with overmolds. The other vest was nonfunctional with dummy miniaturized electronic modules. The purpose of that model was to demonstrate the feel and appearance of the final product (Figure 24).



Figure 24. Nonfunctional FLC Antenna Demonstrates Final Product

In addition to the 18 electronic modules (16 switching and 2 interface) that must be included in each vest there are several bend modules. Those modules contain no electronics, but are simply feedthrough of the electrical signals. Their purpose was to provide a means for routing the conductive textile around a 90-degree corner without bunching the fabric. Those bend modules are included in all the antennas delivered under this program.

The second overmold design was made compatible with the large prototype circuit modules. In the prototype system the conductive textiles connect to the modules via pins and sockets. That method facilitated the test and evaluation phase by enabling easy removal and/or replacement of individual circuit modules. The pins are attached to the electronic circuit board and the sockets are attached to the textile. Connection between the textile and sockets for this version was made through an intermediate, small printed circuit board. The textile conductors were soldered to pads on the intermediate board in the same way that those conductors would be attached to the electronic circuit board in the final version. The overmolding process was applied to the textile/intermediate board interface in this vest (Figure 25).



Figure 25. An Overmolded Antenna System on FLC Vest that can be Tested with Prototype Circuit Modules

Fitting the loops into the FLC vest was very challenging. The two primary issues that arose were (1) keeping the modules properly spaced for functionality without placing modules in uncomfortable spots on the body, and (2) accommodating the FLC vest's level of adjustability. To meet the first challenge, we had to space the modules somewhat unevenly around the loop. The best performance occurs when the modules are evenly spaced. The second challenge was not fully addressed in our prototype. Further development is required to make an adjustable antenna loop. We also strongly recommend that the garment that houses the Merenda antenna be designed around the constraints of the antenna, thereby optimizing comfort and performance.

The weight breakdown of these vests are given in Table 4. Note that the weight of the functional vest does not include the modules.

Table 4. Weight Breakdowns of the Prototype Antenna Vests

Item	Functional Vest	Nonfunctional Vest
FLC vest, as received	1.5 lbs	1.5 lbs
Textile antenna bus, with fiber optics	0.48 lbs	0.60 lbs
Dip coating for waterproofing	0.10 lbs	0.12 lbs
PCBs and overmolding	1.33 lbs	1.19 lbs
Additional fabric on FLC	0.09 lbs	0.09 lbs
Total	3.5 lbs	3.5 lbs

Two pounds for a body-borne antenna may be somewhat high. The weight of the system may be reduced, however, by:

- a. Reducing the width of the textile bus. This optimization will reduce not only the textile weight but the overmold weight, as the overmolded pieces will be smaller. The current width of narrow-woven was produced to meet the inductance requirement given to us. A careful tradeoff study of inductance or conductor width versus antenna efficiency should be performed. It is possible that the weight could be significantly reduced with only a small penalty in performance.
- b. Lowering the density of the overmolding material. Microcellular foaming, for example, reduces the overall density of a polymer block without significantly changing its physical properties.
- c. Designing the overmolds to minimize material usage.

Finally, the fact that the modules take weight out of the radio should be taken into account, as should the possibility of piggybacking other functions onto the Merenda loops.

Two other FLC vests were constructed to be used in a companion contract to the Army at CECOM. The purpose of that contract was to evaluate functional body-borne antennas. Two sets of electronic modules were fabricated under that contract. These vests were provided for integration with the prototype modules.

These vests were completed prior to the development of the overmolding process. They include the same textile conductor but no overmolds. An older version of the FLC was used, resulting in antenna routing through the vests that was different from the overmolded designs. The peripheral length of each loop in these antennas was approximately 70 inches. Since that length is somewhat less than the overmolded versions (74.25 inches), the measured performance will be poorer than the final overmolded structure.

A photo of one of those body-borne antenna systems including a radio was shown in Figure 1. The antenna portion of the system is mounted on a holding fixture that simulates the shape of the human torso. The fixture is constructed from 4-inch PVC and foam rubber.

It is necessary that the antenna be placed on this fixture or a human being at all times in order to avoid stress to the circuit module connections when the unit is laid flat. Since this prototype does not use overmolding, there is not adequate strain relief to prevent damage to those connections. The final configuration will overmold the connection with plastic or rubber for both strain relief and moisture sealing.

The open FLC is shown in Figure 26. The electronics and antenna conductors are sewn inside the garment and covered with fabric material.

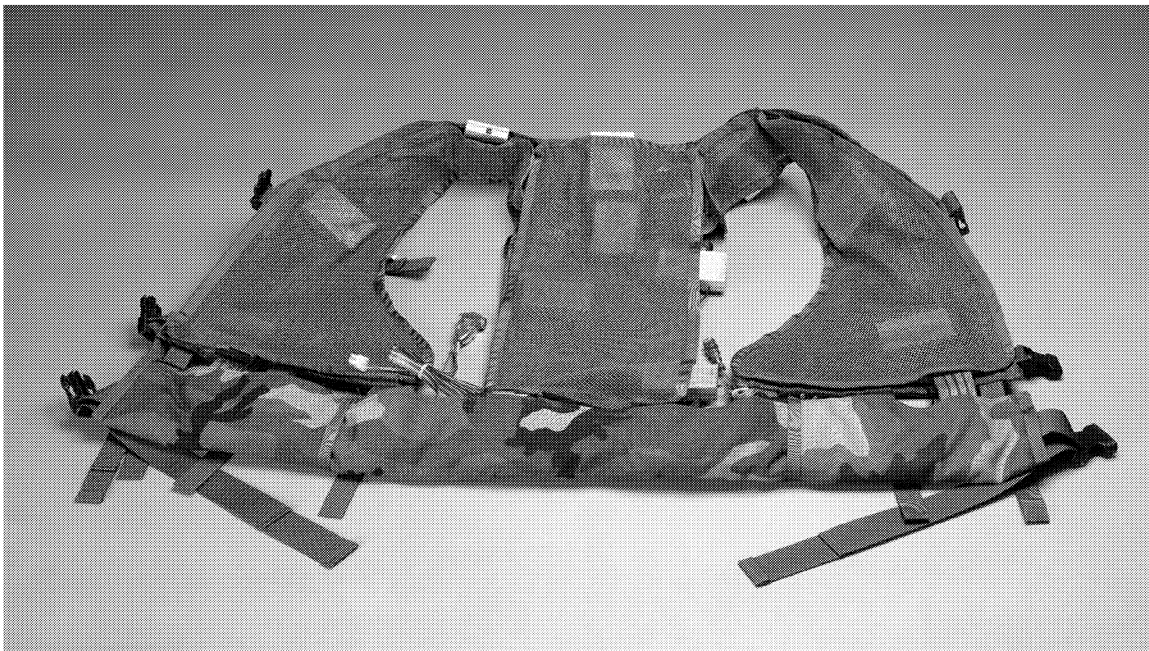

Figure 26. Open FLC with Covered Electronics

The fabric covering has been folded away to expose the electronics in Figure 27. The callouts identify the individual components that were described in Section 2.

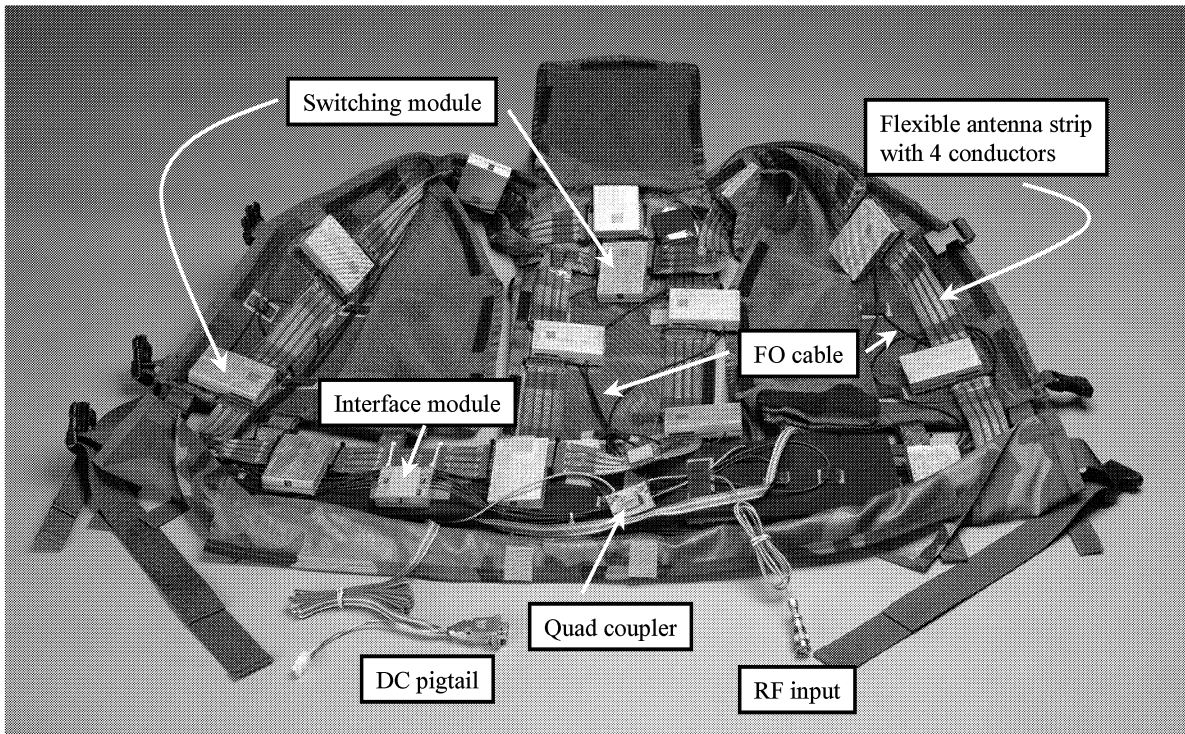

Figure 27. Photo of Open FLC Identifying Electronic Components

SECTION 4

MEASURED RESULTS

4.1 EVALUATION

Although the evaluation of the body-borne antennas was performed under the companion contract to CECOM, the results are shown here in order to demonstrate the viability of these antenna systems.

The purpose of the testing program was to evaluate the performance of the body-borne antenna. Direct measurements were made of radiated signal levels, radiation pattern shape, and the effect of the human body on both radiated levels and pattern shape.

It was difficult to measure improvement factor or efficiency directly. Some bench measurements of individual module performance are shown.

Communication range of the SINCGARS radio with body-borne antennas was evaluated at the BAE Systems' facility, which is located in a suburban environment. The range was compared to that when using 1-meter tape or manpack antennas.

4.2 SIGNAL STRENGTH MEASUREMENTS

The radiated power, pattern shape, and human body effects were evaluated using the signal strength measurement set-up shown in Figure 28.

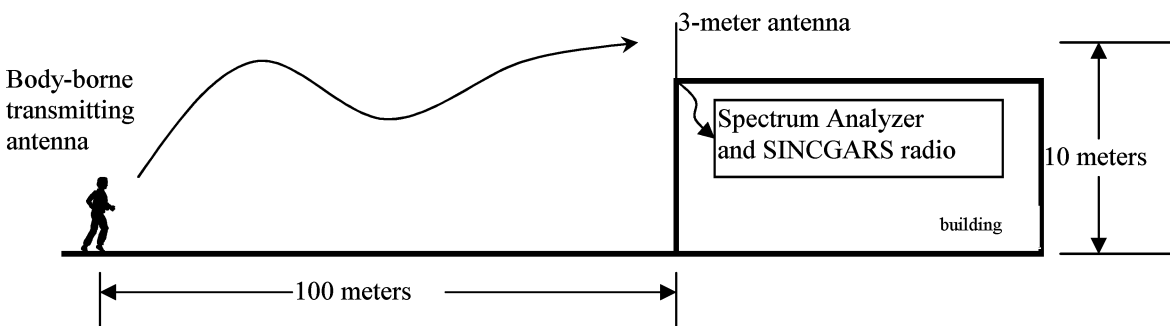

Figure 28. Signal Strength Measurement Test Range

The body-borne antennas were evaluated in the transmit mode. A battery-powered SINCGARS radio is used as a signal source for the body-borne antenna system. When the radio is keyed to transmit, the antenna radiates a signal that is received by a standard 3-meter VHF communication antenna that is located on the roof of the test facility. A photo of the range, as viewed from the receiving antenna, is shown in Figure 29.



Figure 29. Photo of Signal Strength Measurement Range

The received signal is coupled via coax cable to a receiver that is located inside the test facility. The received signal is split. One-half the signal is fed to another SINCGARS radio to enable communication with the operator on the other end of the link. The radio also allows one to monitor voice quality as the signal passes through the body-borne antenna system. The other half of the signal is fed to a spectrum analyzer for an accurate measurement of signal strength.

A photo of the signal strength measurement is shown in Figure 30.

The purpose of the first measurement was to ensure that the Merenda loop radiated the computed signal strength. The test was first performed with the wood-supported square loops. The propagation path loss was computed for the range. The receiving antenna gain is known. It was then possible to predict by calculation the amount of signal that should be received by the spectrum analyzer. A photo of the wooden loop in the range is shown in Figure 31. The measured signal strength and the predicted values are plotted versus frequency in Figure 32.



Figure 30. Spectrum Analyzer Measures Signal Strength

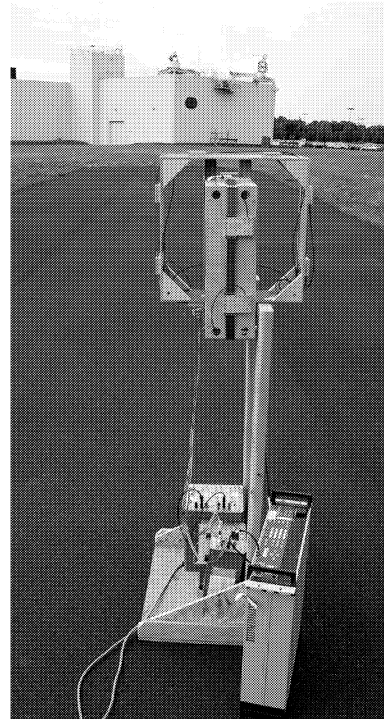

Figure 31. Wood-Supported Loop on Test Range

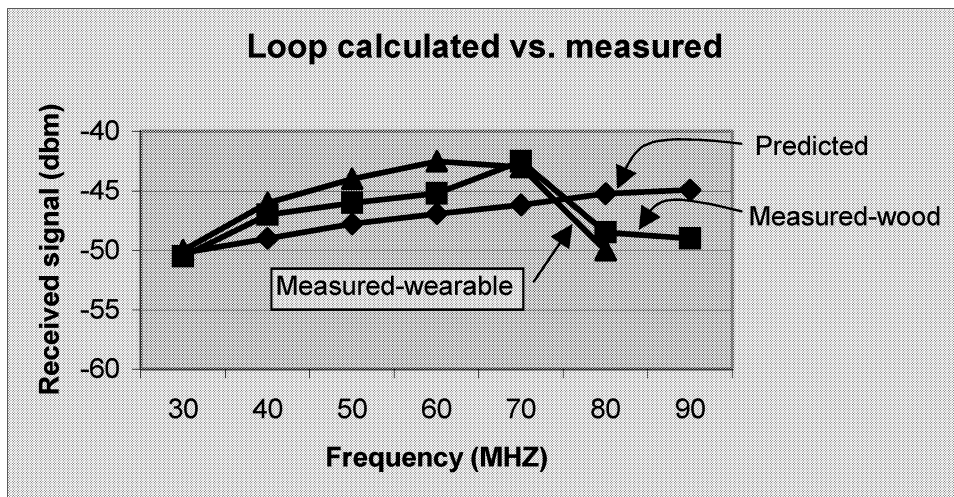

Figure 32. Measured Radiation Levels Agree Well with Predicted Values

In these measurements a signal generator was used to drive the antenna system and the SINCGARS radio was not connected on the receiving end of the link.

The measurements are in excellent agreement with theory, considering several factors that are difficult to predict in a radiating range.

In the next measurement the wearable body-borne antenna performance was compared to that of the wooden-supported loop. The purpose of this measurement was to ensure that the deviation from ideal crossed configuration did not degrade the radiation levels. The measurements of the wearable antenna are also plotted in Figure 32. In order to account for the 3-dB splitter that was used to feed the SINCGARS radio at the input to the spectrum analyzer, 3 dB was added to these measurements. The PVC holding fixture (Figure 33) supports the antenna. The use of the radios only enabled measurements up to 80 MHz in this test.



Figure 33. Wearable Antenna Supported by PVC Fixture

The measured results show little difference between loops in the ideal crossed configuration and those contoured to the human torso in the wearable configuration.

The wearable antenna was then tested on a human. As shown in the accompanying photographs (Figure 34), signal strength was measured in various positions as the person rotated 360 degrees in azimuth and also while crouching and laying down. Radiation pattern effects were evaluated in this test.

The received signal strength is plotted versus that when supported by the holding fixture in Figure 35. The deviation in signal strength as the wearer moves through a full range of positions is shown for three frequencies. The bars represent the extreme limits of the variation. For most orientations the level was near the center of the range.



Figure 34. Wearable Antenna Tested in Various Positions

It was found that the radiation pattern was affected by the location of the handset cord. Signal strength varied by 6 dB depending on the exact location. The above measurements are taken with the handset and cord located below the operator's waist. It would be advantageous in the final radio/antenna design to incorporate a headset with fiber-optic data connection to the radio. The headset could receive its DC power from the antenna strips.

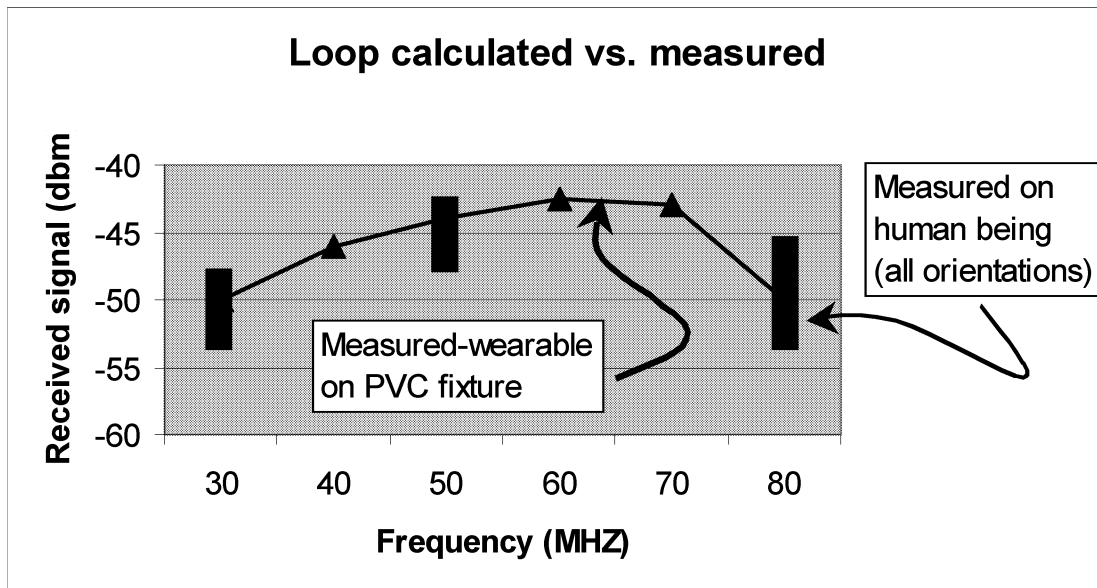

Figure 35. Radiation Level on Human Shows Small Variation with Wearer Orientation

In the final analysis of the data, it was found that the radiated signal, while operating on a human being, had a 95% probability of falling within 3 dB of the predicted level, considering all operating frequencies and possible operator orientations.

It was not possible to directly measure the improvement factor of the nonlinear antenna system for these wearable prototypes. Improvement factor is defined as the ratio of prime power needed to produce a particular radiation level when using the Merenda technique compared to the prime power that would be required to produce the same radiation when using a passive antenna and conventional power amplifier.

A fair comparison requires that the size and configuration of the radiators be identical for the active and passive approaches. It was necessary to use a loop that was fed in eight places for various reasons, as discussed in the previous section. Unfortunately, it is not a simple task to develop a passive loop that is fed in eight places. A single feed loop would not produce the same radiation and would provide an unfair advantage to the active approach.

Improvement factor has been measured for single switching modules using a one-eighth-scale antenna. The results are plotted in Figure 36.

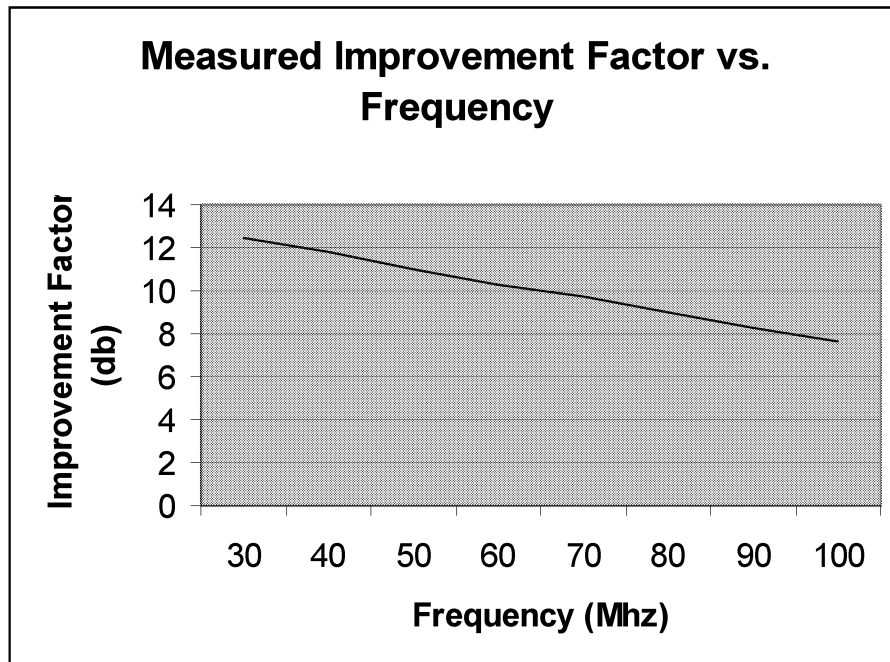

Figure 36. Measured Improvement Factor of Individual Switching Module Demonstrates 10 Times Reduction in Prime Power Requirement

4.3 COMMUNICATION RANGE TESTS

The final, and most significant test, is to evaluate the wearable antenna system in conjunction with SINCGARS radios in a real communication link. In this test, battery-powered radios are hung over the shoulders of two operators at about waist height. The operators each wear an integrated antenna molle as shown in Figure 37.

Testing was performed at the BAE Systems' facility in suburban Long Island, New York. One of the operators stood near the BAE Systems' building while the other walked into the surrounding area. The typical environment is shown in the photos in Figure 38.

The system communication range was measured by noting the distance where the voice quality became unintelligible. Testing was done at low, mid, and upper frequencies in the SINCGARS band.

The output power of the transmitting antenna system was reduced by 6 dB from the predicted maximum limit for exposure to electromagnetic fields. The power was reduced to provide safety margin since the units have not been qualified for human testing at this time.



Figure 37. Two Radio Operators Communicate Via Wearable Antennas



Figure 38. Communication Range Testing

Range contours for the three frequencies are plotted on the map of the vicinity of BAE Systems that is shown in Figure 39. The fixed position operator was located in the back of the building, which is about 10 meters tall. Hence, there is some shadowing when trying to communicate toward the front of the building. In addition, the region in the front of the building is residential with densely packed 2-story homes.

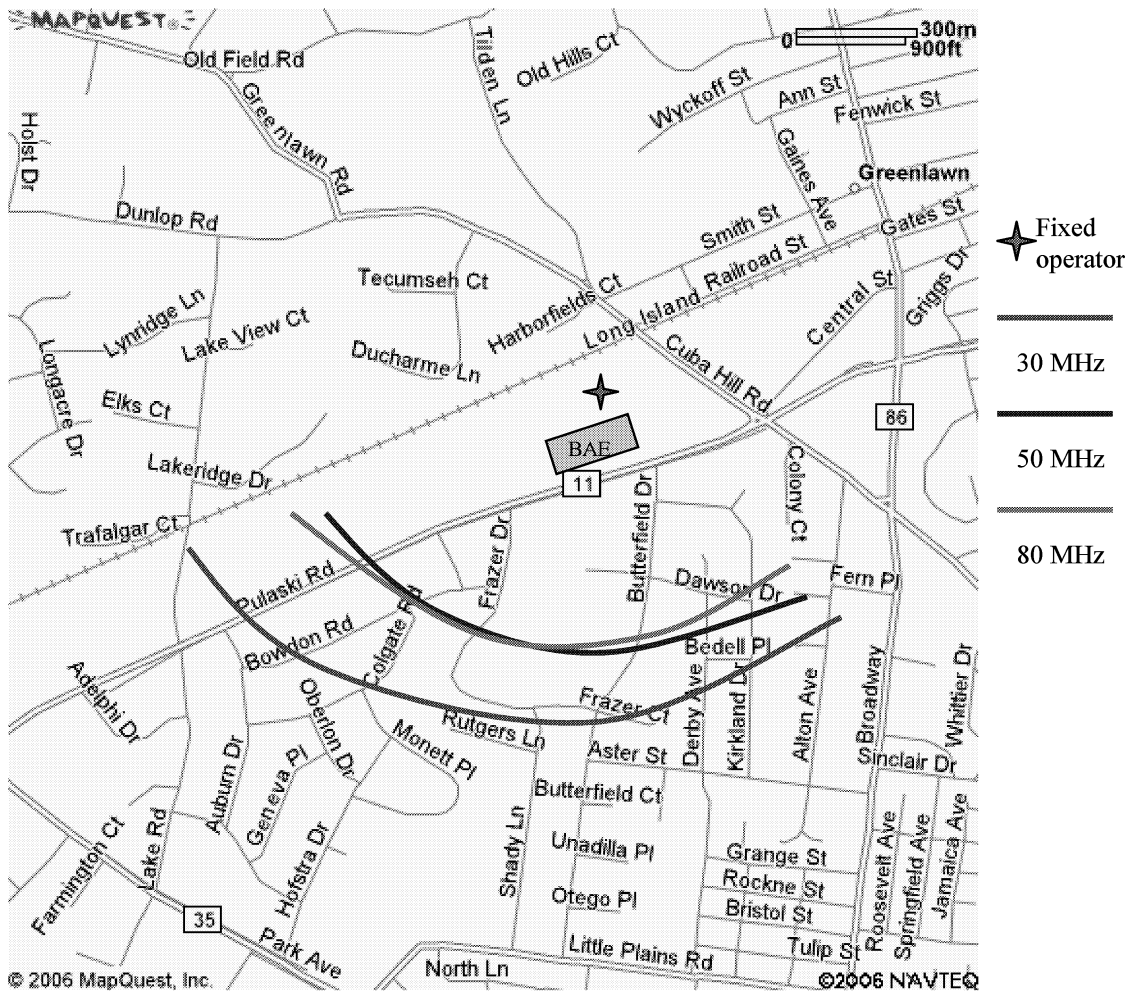

Figure 39. Communication Range Contours when using Body-Borne Antenna Systems

Very high background noise in the vicinity of 50 MHz was observed near the railroad. That may explain the fact that communication range does not decrease in a smooth manner with increasing frequency. The same behavior was observed when using 1-meter tape antennas on both ends of the link.

The tape or manpack antennas were used in selected locations. The radio power was set to medium level (1/4 watt) in order to remain within walking distance. That level is 12 dB below the full power setting. The fourth power variation of range vs transmit level for a ground-to-ground link means that the range, when operating at full power, would be twice that of these observations.

The range of these tape antenna measurements was about 70% of the body-borne antenna range at 30 MHz and about 40% greater at 80 MHz. The measurements were about the same at 50 MHz.

Both the body-borne and manpack ranges can be adjusted to compensate for low power operation. The body-borne antenna radiation can increase by 6 dB. It's range would increase by 40%. Similarly, the manpack radiation can increase by 12 dB to double the range.

The predicted ranges for the suburban Long Island environment based on the measurements and adjustments are given below.

	<u>Range (miles)</u>	
	<u>Body-Borne Antenna</u>	<u>Tape Antenna</u>
30 MHz	1.0	1.0
50 MHz	0.7	1.0
80 MHz	0.5	1.0

4.4 VOICE QUALITY AND FREQUENCY-HOP PERFORMANCE

Comparing the intelligibility over the body-borne link with the tape antenna link made a subjective determination of voice quality. There was no perceptible difference in quality, indicating that the nonlinear active antenna does not distort the modulation properties.

The radios were also operated in the frequency hopping (FH) mode. Two hop sets were loaded into the radios. A partial band set operated between 30 and 55 MHz. A full 30 to 88 hop set was also tested. The communication ranges when operating FH was commensurate with the single channel ranges in the same frequency band.

The voice quality is inferior when operating in the FH mode both in the body-borne and tape antenna tests. There was no perceptible difference in quality when comparing the two antenna systems.

The body-borne system exhibited an anomaly after cessation of the voice transmission. Although the actual voice was clear, there were several seconds of noise that could be heard on the receiving end after releasing the push-to-talk switch on the transmitting side of the link. The BAE Systems' Receiver-Transmitter (RT) switch immediately switches to the receive mode upon release of the switch. It has been speculated that some FH synchronization data is transmitted after the voice is complete. The BAE Systems applique would suppress that transmission and might cause the receive end noise. The theory was verified by keying BAE Systems' switch for a period longer than the push-to-talk radio switch. When operated in that manner, the noise was no longer there. This problem was not anticipated and can be easily eliminated in the next design.

SECTION 5

CONCLUSIONS AND RECOMMENDATIONS

A wearable body-borne antenna system has been successfully implemented by integrating conductive textile webbing into a Fight Load Carrier (FLC).

The antenna system met expectations and performed well in field tests at the BAE Systems facility both on and off the human body. The antenna system was designed to operate in the VHF SINCGARS band. The measured communication range using body-borne antennas on both ends of the link was comparable to that when using standard 1-meter man-pack antennas.

The crossed-loop antenna using the flexible textile in an FLC configuration demonstrated radiation properties that are independent of both the human operator and his orientation. There was little degradation in performance, even with the human host lying flat on the ground.

The flexible conductive textile consisted of a narrow-woven structure that included tinsel wires as selected warp threads to implement four isolated conductive strips. Eight fiber-optic cables used to distribute control signals to the electronic modules were embedded in the narrow-woven.

Waterproofing of the textile conductors was successfully implemented by dip-coating the textile in a thinned thermoplastic urethane.

A method was developed for attaching the textile conductors to the electronic modules that provides a moisture seal and strain relief. That method uses a plastic overmold of the connection and electronic module. The plastic overmold was shaped to maximize comfort to the wearer.

Although significant progress was made and the production processes determined, further effort is required to refine those processes. Further testing and adjustments in the consistency and dip duration of the watersealing process must be undertaken. Significant effort remains in the overmold process in order to convert to a lower temperature operation that does not damage the electronics or the plastic fiber-optic cable.

In the development of a producible and reliable body-borne antenna system, the most significant task is the refinement of the electronic modules. The prototype modules are large, fragile, and expensive to manufacture. The next phase in the body-borne development is to miniaturize, ruggedize, and reduce the cost of the electronic modules. That can be accomplished through the development of a chip-set of monolithic integrated circuits.

Preliminary estimates indicate that cost, size, weight, and performance goals can be met with the monolithic approach. Furthermore, it is estimated that the prime power efficiency of that approach will be two to four times better than the prototype.

Even greater improvement is possible by redesigning the SINCGARS radio to incorporate the body-borne antenna function. The efficiency is improved by eliminating duplicate functions. Furthermore, a redesigned waveform using digital modulation of compressed voice could increase the communication range by a factor of two to three times and enable relay and networked operation.

The best design incorporates the body-borne antenna into a soldier system. In that way other functions might be piggy-backed onto the loop antennas and use its power bus. That method could reduce the overall weight and cost and enhance the performance of the communication system.

LIST OF ACRONYMS AND ABBREVIATIONS

ANSI	American National Standards Institute
CECOM	Communications Electronic Command
DARPA	Defense Advanced Research Project Agency
dB	decibel
DC	Direct Current
EIRP	Effective Isotropic Radiated Power
FET	Field Effect Transistor
FH	Frequency Hopping
FLC	Fight Load Carrier
FO	Fiber Optic
IEEE	Institute of Electrical and Electronics Engineers
IR&D	Independent Research and Development
LCR	Inductance, Capacitance, Resistance
MHz	Megahertz
PC	Personal Computer
PCB	Printed Circuit Board
PVC	Polyvinyl Chloride
RF	Radio Frequency
RT	Receiver-Transmitter
SINCGARS	Single Channel Ground Airborne Radio System
SWAT	Soldier Worn Antenna Technology
THF	Tetrahydrofuran
VHF	Very High Frequency
VSWR	Voltage Standing Wave Ratio
WIPL	Wire and Plate

