

# **Issues in Air Force Science and Technology Funding**

Donald C. Daniel

**Center for Technology and National Security Policy  
National Defense University**

**February 2006**

# Report Documentation Page

Form Approved  
OMB No. 0704-0188

Public reporting burden for the collection of information is estimated to average 1 hour per response, including the time for reviewing instructions, searching existing data sources, gathering and maintaining the data needed, and completing and reviewing the collection of information. Send comments regarding this burden estimate or any other aspect of this collection of information, including suggestions for reducing this burden, to Washington Headquarters Services, Directorate for Information Operations and Reports, 1215 Jefferson Davis Highway, Suite 1204, Arlington VA 22202-4302. Respondents should be aware that notwithstanding any other provision of law, no person shall be subject to a penalty for failing to comply with a collection of information if it does not display a currently valid OMB control number.

1. REPORT DATE <b>FEB 2006</b>		2. REPORT TYPE		3. DATES COVERED <b>00-00-2006 to 00-00-2006</b>	
4. TITLE AND SUBTITLE <b>Issues in Air Force Science and Technology Funding</b>				5a. CONTRACT NUMBER	
				5b. GRANT NUMBER	
				5c. PROGRAM ELEMENT NUMBER	
6. AUTHOR(S)				5d. PROJECT NUMBER	
				5e. TASK NUMBER	
				5f. WORK UNIT NUMBER	
7. PERFORMING ORGANIZATION NAME(S) AND ADDRESS(ES) <b>National Defense University, Center for Technology and National Security Policy, 300 5th Avenue, Washington, DC, 20319-6000</b>				8. PERFORMING ORGANIZATION REPORT NUMBER	
9. SPONSORING/MONITORING AGENCY NAME(S) AND ADDRESS(ES)				10. SPONSOR/MONITOR'S ACRONYM(S)	
				11. SPONSOR/MONITOR'S REPORT NUMBER(S)	
12. DISTRIBUTION/AVAILABILITY STATEMENT <b>Approved for public release; distribution unlimited</b>					
13. SUPPLEMENTARY NOTES <b>The original document contains color images.</b>					
14. ABSTRACT					
15. SUBJECT TERMS					
16. SECURITY CLASSIFICATION OF:			17. LIMITATION OF ABSTRACT	18. NUMBER OF PAGES <b>24</b>	19a. NAME OF RESPONSIBLE PERSON
a. REPORT <b>unclassified</b>	b. ABSTRACT <b>unclassified</b>	c. THIS PAGE <b>unclassified</b>			

The views expressed in this article are those of the author and do not reflect the official policy or position of the National Defense University, the Department of Defense or the U.S. Government. All information and sources for this paper were drawn from unclassified materials.

---

**Dr. Donald C. Daniel** is a Distinguished Research Professor at the National Defense University's Center for Technology and National Security Policy. He is also a former Air Force Deputy Assistant Secretary for Science, Technology and Engineering and was the first Executive Director of the Air Force Research Laboratory. He concluded a 30-year career with the Department of the Air Force in 2002.

***Defense & Technology Papers are published by the National Defense University Center for Technology and National Security Policy, Fort Lesley J. McNair, Washington, DC. CTNSP publications are available online at <http://www.ndu.edu/ctnsp/publications.html>.***

# Contents

Introduction.....	1
The Air Force S&T Framework.....	2
History of Air Force S&T Funding.....	5
The Bush Years.....	7
Issues in Air Force S&T Funding.....	10
The Way Ahead .....	17
S&T Areas to Emphasize and De-Emphasize .....	19
Concluding Thoughts.....	20



# Introduction<sup>1</sup>

---

Just a few years ago there was considerable consternation and hand wringing over the Air Force science and technology (S&T) budget. This culminated in March 2000, when the Air Force was attacked verbally by its staunchest supporter, the Air Force Association, in a surprise article (to Air Force senior leadership) on “The Shortfall of Science and Technology.”<sup>2</sup> This article bluntly pointed out that the Air Force had gone from first to last among the Armed Services in the amount it spends on science and technology. The article stated that, since fiscal year 1989, the Air Force budget for research and advanced technology development had fallen by more than half and was expected to continue to decline; by 2005, total obligation authority allocated to science and technology was projected to drop almost 30 percent below its 1993 level. The article observed that “these are alarming trends for a service that hangs its hat on technological superiority.” During this same timeframe, other voices, including Congress, the Congressional Research Service, the Office of the Secretary of Defense, and the National Research Council, voiced similar concerns.<sup>3456</sup>

Five years later, we see an entirely different picture. No one seems especially concerned about the Air Force or DOD top lines in science and technology funding. In fact, just looking at these numbers for DOD as a whole and the Air Force in particular, we see dramatic increases totaling approximately 50 percent for each during the years of the Bush administration. Even though the current issues surrounding S&T funding are perhaps deeper and more numerous than in the past, they do not get the attention that they did a few years ago. Among these issues are: determining what the S&T top line should be; the distribution of funding among the major elements of the program; the value of

---

<sup>1</sup> The author gratefully acknowledges the research and editorial assistance of Ms. Cheryl Loeb, from the National Defense University’s Center for Technology and National Security Policy, in the preparation of this paper. Her thoroughness, creativity, and capacity for work are truly exceptional.

<sup>2</sup> Correll, John T., “The Shortfall of Science and Technology,” *Air Force*, Vol 83, No 3, March 2000.

<sup>3</sup> The “Sense of Congress Regarding Defense Science and Technology Program” for the FY 2000 National Defense Authorization Act specifically stated, “It is the sense of Congress that the Secretary of Defense has failed to comply with the funding objective for the Defense Science and Technology Program, especially the Air Force Science and Technology Program, as stated in section 214(a) of the Strom Thurmond National Defense Authorization Act for fiscal Year 1999 (Public Law 105-261; 112 Stat. 1948), thus jeopardizing the stability of the defense technology base and increasing the risk of failure to maintain technological superiority in future weapon systems.”

<sup>4</sup> Moteff, John D., “Defense Research: DOD’s Research, Development, Test and Evaluation Program,” CRS IB10062, November 8, 2001. Among other things, Mr. Moteff stated, “Congress has been particularly concerned about the level of Air Force S&T over the last few years.”

<sup>5</sup> Etter, Delores M. “A Glimpse into the DOD S&T Program,” National Academy of Engineering, 2001. In this report, then Deputy Under Secretary of Defense Etter stated in addressing the funding of the three Services, “Note that the Air Force which was the largest investor in FY 89, is the smallest investor in FY01.”

<sup>6</sup> National Research Council, *Review of the U.S. Department of Defense Air, Space, and Supporting Information Systems Science and Technology Program (2001)*. Available online at: <<http://www.nap.edu/books/0309076080/html/>>.

defense basic research (perceived and actual); Congressional earmarks and additions; the Small Business Innovative Research Program (SBIR); the Independent Research and Development program (IRAD); the impact of programs from the Defense Advanced Research Projects Agency (DARPA); highly classified programs; and the impact of the latest round of Base Realignment and Closure (BRAC). This paper looks at these issues and offers some suggestions for the future. Before doing so, however, it is interesting and perhaps instructional to look at the framework of Air Force science and technology and a long-term history of Air Force S&T funding.

## **The Air Force S&T Framework**

Within all elements of the Department of Defense (DOD), S&T funding is categorized by levels of maturity. The most fundamental level is basic research, followed by applied research (sometimes called exploratory development), and concluding with advanced technology development. This three-tier model of program elements has been in place for decades and is widely recognized by all who are involved in the planning, programming, and execution of the various aspects of the program. These elements are known by the alpha-numeric code assigned to them in the annual President's budget submission to Congress. Basic research elements are coded with the numbers 61 as the first non-zero entries, applied research with 62, and advanced technology development with 63. This shorthand notation is frequently used in describing the elements. For example, the primary basic research program element for the Air Force is 0601102F, a typical applied research program element is 0602602F, and a typical advanced technology development program element is 0603601F.<sup>7 8</sup>

A model of the interrelationship of the Air Force S&T program elements is shown on figure 1. This model also illustrates the other major program elements that make up the total research and development picture. It further points out that, at least in the case of the Air Force, not all 6.3 programs are considered to be S&T, with more mature advanced technology development programs being executed outside the science and technology community. This practice sometimes leads to interesting annual accounting variations by the Air Force on what is, and is not, considered to be science and technology.

---

<sup>7</sup> Program element 0602602F is the Air Force applied research program element for Conventional Munitions.

<sup>8</sup> Program element 0603601F is the Air Force advanced technology development program element for Conventional Munitions.

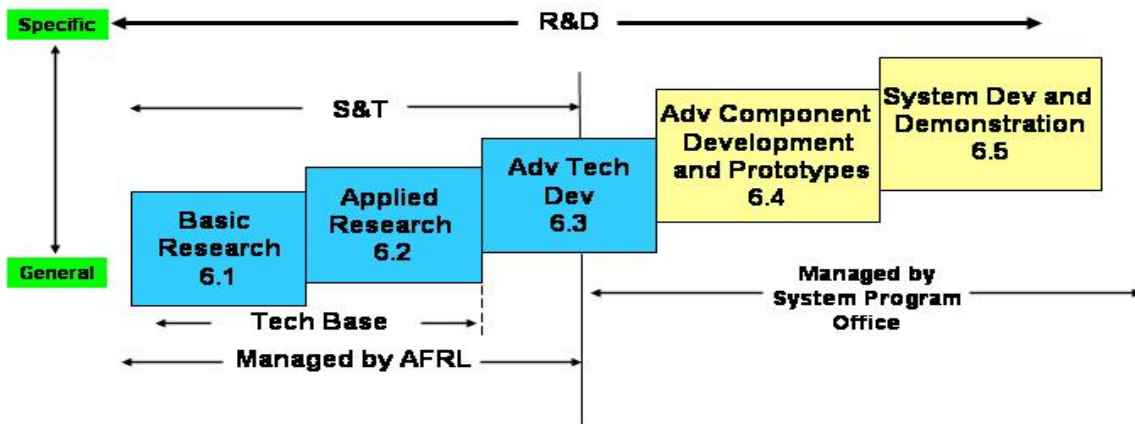

Figure 1. Air Force Research and Development Model

The “stair-stepped, nearly linear, three-level” model of S&T progression shown on figure 1 has been used for decades. Some analysts question the validity of this model, given the more rapid development of technology today. This concern will be discussed in more detail below. Suffice it to say for now that a case could be made for either a much more interactive three-level model or perhaps, better yet, an interactive two-level one.

The model shown on figure 1 also indicates that the entire S&T program of the Air Force is managed by the Air Force Research Laboratory (AFRL). This is not the case for the Army Research Laboratory and Naval Research Laboratory, both of which focus almost exclusively on basic and applied research, with other elements of the Army and Navy executing the advanced technology development portion of these services’ S&T portfolios.

As figure 2 illustrates, there are 10 primary AFRL directorates, with each specializing in either a functional or technical discipline. The Air Force Office of Scientific Research (AFOSR) manages all basic research for the Air Force and controls all basic research funding, although the other directorates conduct basic research via AFOSR sponsorship. Each of the other nine technical directorates typically has one applied research program element and one advanced technology development program element. Thus, there are a total of approximately 20 applied research and advanced technology development

program elements within AFRL.<sup>9</sup> More will be said later on the AFRL structure and distribution of funding within it.

## Air Force Research Laboratory

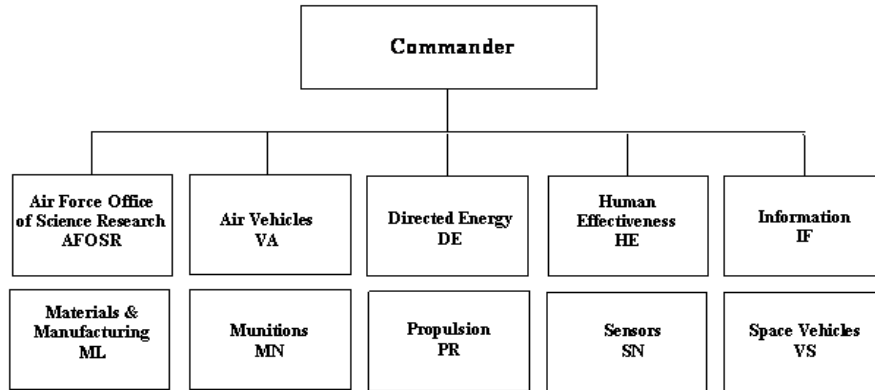

Figure 2. Air Force Research Laboratory Organization

<sup>9</sup> As of this writing, AFRL is considering a new organizational structure, but this has not yet been made public nor has it been adopted by the Air Force.

## History of Air Force S&T Funding

A graphical history of the combined (6.1 + 6.2 + 6.3) S&T appropriated funding for the Air Force over more than forty years is given on figure 3. The figure gives the funding in constant FY 03 dollars, so there is considerable adjustment in the early years, but this is perhaps the best way to compare “buying power” of this funding over many decades. As can clearly be seen, the program was at its highest in the early 1960s, and the trend in funding has generally been downward since then, with two exceptions. The first exception was in the mid-to-late eighties, and the second has been during the past five years.

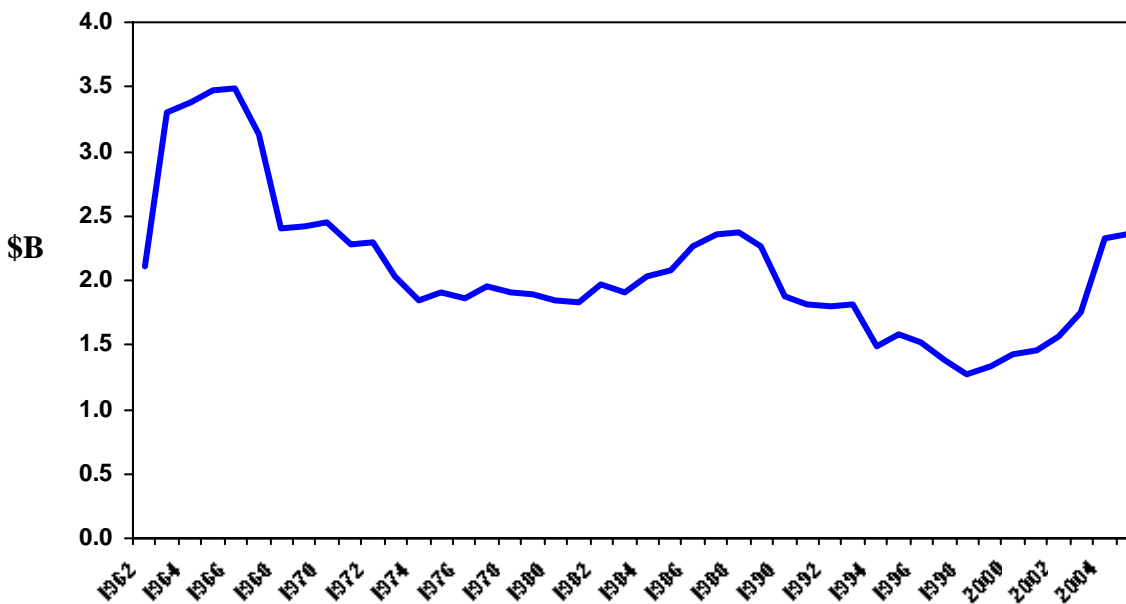

Figure 3. Air Force Science and Technology Funding Appropriation History (Constant FY 03 Dollars)

A few years ago Dr. Roy Phillips graphically depicted the correlation of political, operational, technical, and platform events over roughly the same period of time as shown for the above funding history.<sup>10</sup> To illustrate the variations in Air Force S&T funding during this period of time, the following chart shows an overlay of this funding over these events.

<sup>10</sup> At the time this figure was generated, Dr. Phillips was working for the Air Force Office of Scientific Research. He subsequently moved to the staff of the Air Force Deputy Assistant Secretary (Science, Technology and Engineering) where he continued to refine the model. Dr. Phillips now works for the Air Force Director of Strategic Plans.

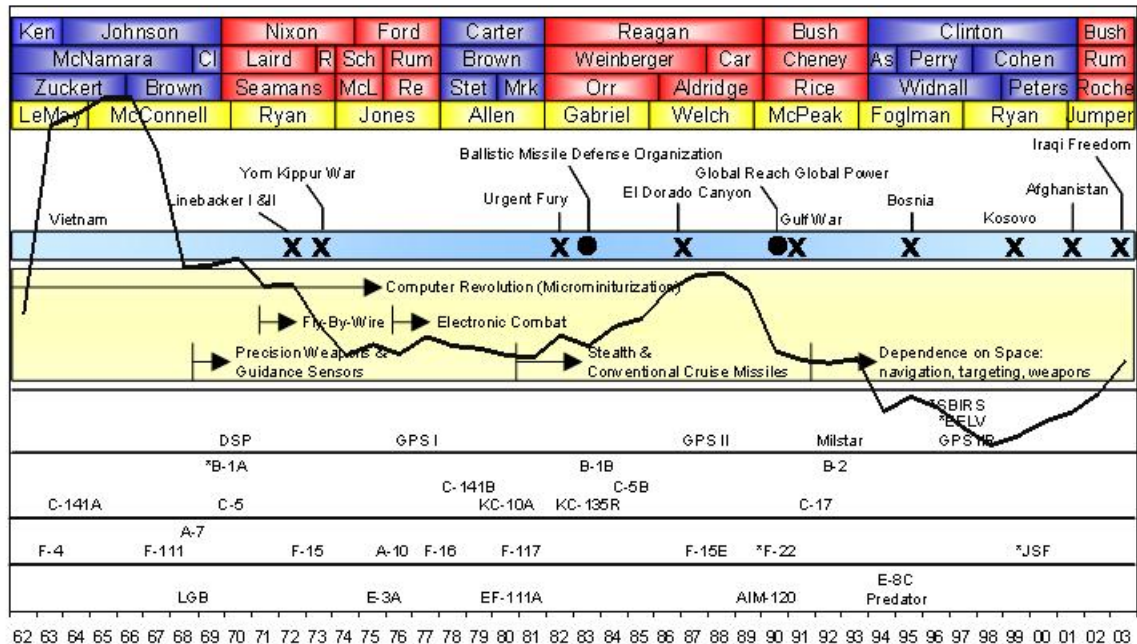

Figure 4. Air Force S&T Funding Correlated with Political, Operational, Technical, and Platform Events

The top four lines of figure 4 show the succession of Presidents, Secretaries of Defense, Secretaries of the Air Force, and Chiefs of Staff of the Air Force. The first three categories are also color coded by political party—blue for Democrats and red for Republicans. The next series of events depicts major military operations, from Vietnam to Operation *Iraqi Freedom*. The next level down shows the introduction of major technologies, and the final level gives indications of the time frame when major platforms were introduced.<sup>11</sup>

There is no single category of events that has driven Air Force S&T funding to the various levels it has seen during this time. Rather, it is a combination of different events. The very high peak in the early 1960s was, no doubt, driven by President Kennedy’s goal of placing a man on the moon and returning him to earth safely. This goal clearly captured the spirit of the nation and enjoyed wide public and Congressional support. Although it was not a military goal, military S&T benefited from the broad and deep

<sup>11</sup> In some cases the major system is shown with an asterisk. This indicates that an early version, or prototype, was flown at this approximate time.

national support for technology and the close correlation that was perceived between civilian rockets/space technology, and military technology.

In the late 1960s, however, the realities and cost of the Vietnam War hit, and the steepest decline ever seen in Air Force S&T funding began. This downward slope continued after the conflict was concluded and perhaps reflected the Congress's attitude toward the military. S&T funding then went through a period of approximately 10 years when it was relatively flat. This was followed by the "Reagan build-up" years (although S&T funding did not enjoy the same rate of increase that military budgets did in general).

The Reagan build-up was followed by the collapse of the Soviet Union, the Clinton administration, and the "peace dividend." This combination of events led to the second steepest decline of Air Force S&T funding in the history of the Service. The decline ended in 2000 based on a number of events, with pressure by Congress being foremost. The early years of the current decade have subsequently shown significant annual increases in the President's budget and by Congress, although Air Force S&T funding has still not quite returned to the high of the Reagan years and is nowhere near the peak of the 1960s. It is also interesting to note that the two previous peaks have been just that—peaks. They typically took 4–8 years to build and were not sustained. This would suggest that the current buildup has just about run its course and, if history is any guide, it will not be sustained.

## **The Bush Years**

S&T funding in recent years, particularly during the Bush Administration, deserves a more detailed look, because many of the key players in the administration and in Congress during that time are still in position or have been succeeded by individuals with similar leanings. The top lines of every major portion of S&T funding appropriated to DOD, as shown on figure 5, have increased during this timeframe.

As noted earlier, Air Force S&T funding had dropped significantly lower than that of the Army and Navy by 2001. It can clearly be seen to rebound somewhat in recent years, but it is still short of the dramatic increase in Army and OSD funding during this time.<sup>12</sup> Another reason for the increase in service funding, and the subsequent level funding in OSD between 2003 and 2004, was OSD "devolvement" of certain elements (primarily in basic research) of its program.<sup>13</sup>

---

<sup>12</sup> The significant increase in OSD funding is driven primarily by funding allocated to DARPA. Other OSD S&T funding included in this line includes the Defense Threat Reduction Agency and the Missile Defense Agency.

<sup>13</sup> Then Under Secretary of Defense (Acquisition, Technology and Logistics) Mr. Pete Aldridge wanted to get his OSD staff out of the business of actively managing programs and thus instituted the "devolvement" strategy. Since most of the money devolved had passed from OSD to the services in previous years after it was appropriated to OSD, this devolvement resulted in no net increase of service S&T programs.

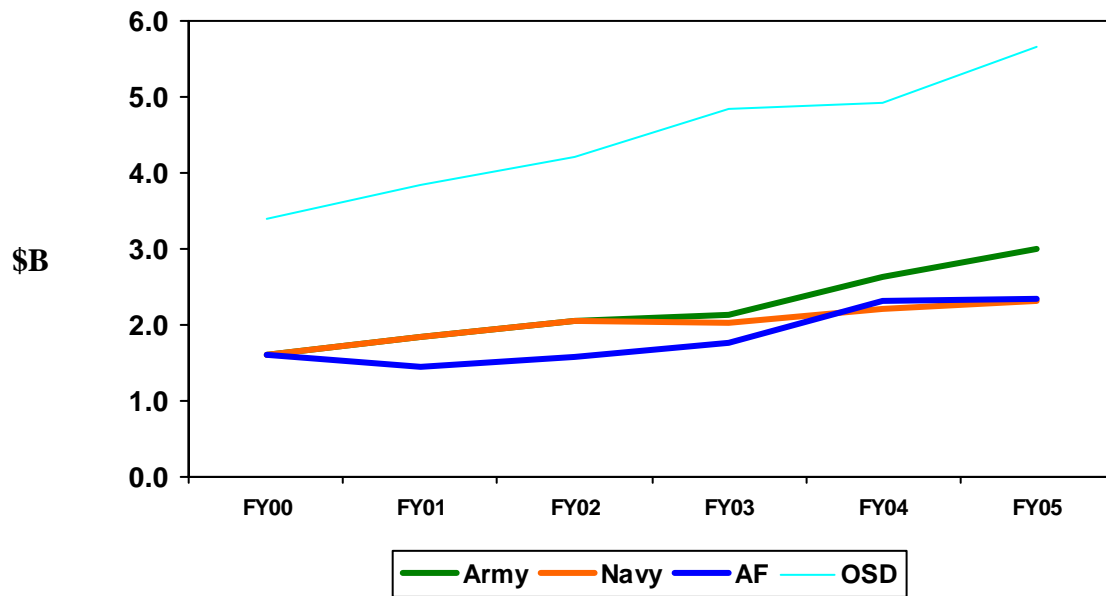

Figure 5. Recent Service and OSD S&T Funding Trends (Then-Year Dollars)

Another interesting, and to some troubling, aspect of S&T funding during the current administration is the distribution of funds among the three fundamental areas—basic research, applied research, and advanced technology development. Figure 6 gives some indication of this by comparing the distribution in then-year dollars for fiscal years 01 and 05. As can be seen, there is a significant shift from the percent allocated to advanced technology development, from 44 percent of the total in FY 01 to 52 percent of the total in FY 05. There is a corresponding decrease in basic research from 15 percent in FY 01 to 11 percent in FY 05. The applied research category also decreases significantly, from 41 percent in FY 01 to 37 percent in FY 05. Of the \$4.3 billion increase in defense S&T during this time span, \$2.9 billion went to advanced technology development, \$1.2 billion went to applied research, and only \$0.2 billion went to basic research. To many, this focus on the near-term and lack of support for long-term basic research is seen as a disturbing, and perhaps even alarming, trend.

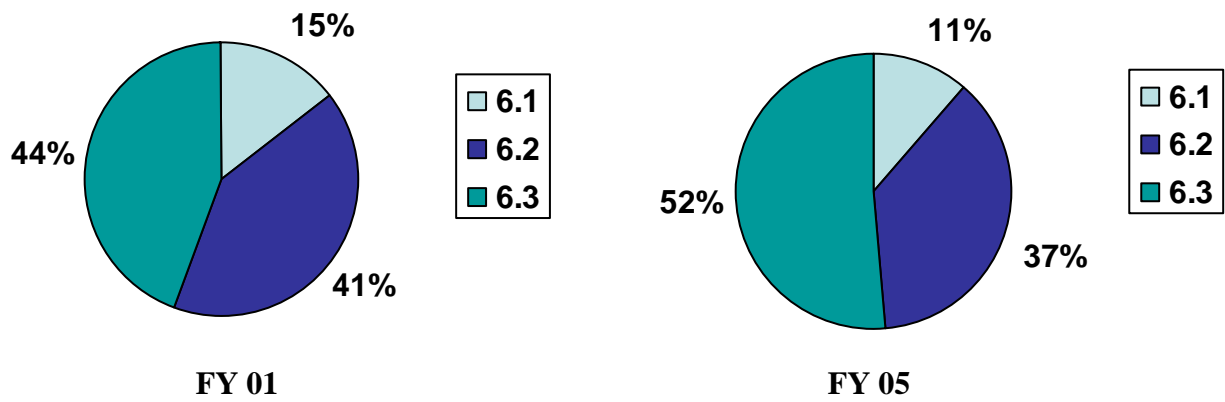

Figure 6. Total DOD S&T Funding Allocations for Fiscal Years 2001 and 2005 (President's Budget Request, Then-Year Dollars)

# Issues in Air Force Science & Technology Funding

---

*The Top Line.* The total amount of funding allocated to Air Force S&T (the S&T top line) was *the* issue half-a-dozen years ago. That is not the case now. It is difficult, if not impossible, to find a single source in the past few years that has noted this as a concern and, in studying the top line numbers, it is easy to see why. Air Force S&T funding has increased by 50 percent under the Bush Administration. In doing so, however, the funding roller coaster may have merely added another peak to a history of up-and-down funding.

The initial goal/policy of the current administration was to increase DOD S&T funding to 3 percent of the total military budget, and appropriations by Congress have more or less done this. These appropriations have also seen very large Congressional additions each year to all service S&T budgets to meet this goal.

It has been commonplace for many years to express the desired amount of S&T funding in terms of a percentage of overall military funding. This idea, however, is not in the best interest of science and technology. S&T is a long-term proposition and has long-term payoffs. In spite of the fact that much is made of the rapid pace of technology today, this is not uniformly the case and many (most?) of the overnight wonders that seem to pop up in technology are often the results of years, even decades, of fundamental research that, by and large, is invisible, or has little interest, to the public or to senior military officials.

The Air Force and the Nation would be better served if science and technology was sustained at a constant level (adjusted only for inflation) and did not undergo the fluctuations that have been repeatedly seen over the past 50 years. *Stability of funding, at an appropriate top line level, is the single most important factor to a long-term, productive S&T program.* This will be especially important for the coming years as we will invariably see a downturn in S&T funding if history repeats itself. What constitutes “an appropriate level” is arguable, but one of the better arguments was put forward by the Defense Science Board nearly a decade ago when they stated that a DOD S&T baseline of \$8 billion seemed to be a good value.<sup>14</sup> This would be about \$9.5 billion in current dollars, with an appropriate Air Force share being perhaps \$2.3 billion.<sup>15</sup>

*Distribution of Funding.* This is the S&T funding issue of most concern today. In spite of the impressive increases to DOD S&T funding during the past five years, the vast majority of these increases have gone to advanced technology development (see figure 6). This is not altogether surprising in a Republican administration since the vast majority

---

<sup>14</sup> Defense Science Board, “Report of the Defense Science Board Task Force on Defense Science and Technology Base for the 21<sup>st</sup> Century,” 30 June 1998. Available online at: <<http://www.acq.osd.mil/dsb/reports/sandt21.pdf>>.

<sup>15</sup> As a comparison, the FY 05 President’s budget called for \$10.6 billion in DOD S&T funding and the amount appropriated by Congress was \$13.3 billion. This same budget called for \$1.9 billion in AF S&T and the amount appropriated by Congress was \$2.4 billion.

of this 6.3 funding is contracted by government with the defense industry. During this same timeframe, applied research has only increased modestly and still has not recovered adequately from the near disastrous downturn of the 1990's. *The most severe problem in AF S&T funding, however, is in basic research.* A close examination of Air Force basic research funding will show that it has actually *declined* in buying power despite the impressive increases of the past half-decade in overall S&T funding.<sup>16</sup> This is a potentially long-term catastrophic problem for the Air Force. It is also interesting to note that, being the smallest of the three budget categories, a modest positive adjustment in the amount allocated to basic research would be a significant percentage increase to this part of the program.

The applied research program of the Air Force has, at best, held its own in recent years. This portion of the program, more than the other two, supports the AFRL infrastructure and in-house S&T program. The relative strength and value of AFRL is more closely aligned to this aspect of the program than any other. *Stability of applied research funding at an appropriate level would do more to stem the criticism of AFRL, and more importantly, produce better products for the Air Force than any other single adjustment that could be made in Air Force S&T funding.*

Given a proposed budget of approximately \$2.3 billion, a distribution that would best serve the Air Force would be approximately: \$0.6 billion for basic research, \$1.2 billion for applied research, and \$0.5 billion for advanced technology development. This distribution would be a significant increase in basic research, a small increase in applied research, and a small decrease in advanced technology development.<sup>17</sup> Congress would then have to exercise considerable discipline in (a) not cutting basic research and (b) not adding the significant amounts of money that they have done in the recent past to advanced technology development.

There are some who are arguing that the traditional 6.1/6.2/6.3 planning, programming, and budgeting system is a relic of the past and that it should be replaced. This argument should get careful scrutiny and may have some merit. At a minimum, recognition must be given to the fact that there is not a rigid, linear hierarchy here, and that some overlap and even more interaction is desired to more rapidly develop and transition technology from the laboratory to the user. Consideration should also be given by DOD to establishing a two-tier system, but again with the understanding that some overlap and considerable interaction is desirable.

*The Value of Basic Research.* Basic research has traditionally been the toughest element of the Air Force S&T program for most senior military leaders to embrace, appreciate, or even understand. The payoff is long-term, and the short-term impact of funding cuts is

---

<sup>16</sup> The Air Force Defense Research Sciences (PE 0601102F) President's Budget for FY 95 was approximately \$265 million in FY 05 dollars. The FY 05 President's Budget called for \$216 million. This latter number is the "core" AF basic research funding after subtracting the amounts added in FY 03 by OSD in their devolvement exercise.

<sup>17</sup> The FY 06 President's Budget for Air Force S&T calls for \$0.341 billion in basic research, \$0.852 billion in applied research, and \$0.788 billion in advanced technology development.

minimal. In fact, it is probably safe to say that no currently serving Air Force General Officer would risk a negative operational impact during the remainder of his or her time on active duty as a result of cutting the current 6.1 budget. They are, however, robbing the current crop of second lieutenants, even younger future officers, and the country as a whole of capability and undreamed of options in the decades ahead. General Hap Arnold, the founder of the United States Air Force, and Dr. Theodore von Karman, the first Chairman of the Air Force Scientific Advisory Board, understood this. Every officer in the Air Force should have von Karman's report to Arnold, *Toward New Horizons*, near the top of their mandatory reading list.<sup>18</sup> The philosophy of this amazing document, completed at the end of World War II, is still relevant. More than any other document of its kind, it helped form the vision of the United States Air Force and forge the links that this service has always had with the scientific community.

In addition to the breakthrough scientific results it produces, the Air Force basic research program also provides another excellent potential value. The vast majority of the Air Force basic research program is executed via grants and contracts by dozens of top-ranked United States universities. In addition to investigating Air Force-relevant fundamental scientific and engineering phenomena, this relatively modest portion of the S&T program also uses a low-cost labor source—graduate students—for much of the work. The Air Force should take much better advantage of this fact than it does as it tries to recruit future scientists and engineers to work in its research and development activities. The graduate students develop not only a familiarization with Air Force-relevant topics, but they also develop a degree of affinity for the same thing that attracts most uniformed officers to the service—a love of flight. Better advantage should be taken of this in the recruiting of young civilian and military scientists and engineers. It is especially important as the Air Force shapes its technical workforce of the future in light of large pending retirements among the current very mature civilian technical workforce.

Finally, the time has come for a major national initiative in basic research. The Air Force, as the world's most technically advanced military service, should be a leader in this activity. It is by far the lowest-cost option with the highest potential return on investment from a national security viewpoint. The United States has not seen such an initiative since the "space race" days of the late 1950's and early 1960's. Much of what we enjoy today in electronics, information technology, directed energy, and materials can be traced to basic research in this earlier time frame, and it is time to reinvigorate the nation along this line.

*Congressional Earmarks and Additions.* Congressional earmarks and additions have been both a curse and a blessing to the Air Force.<sup>19</sup> During the rather dramatic downturn of the 1990's, Congress was an active party in reducing Air Force S&T funding. As shown on

---

<sup>18</sup> For an excellent review of *Toward New Horizons*, the reader is referred to: *Prophecy Fulfilled "Toward New Horizons and Its Legacy,"* Michael H Gorn (Ed), Air Force History and Museum Programs, 1994.

<sup>19</sup> In this publication, earmarks refer to language in the annual Defense Authorization Bill that directs the Air Force to conduct certain research and/or development but does not provide funding to do so; additions refer to increases in the Defense Appropriation Bill that provide additional direction and funding.

figure 7, even though the administration was submitting budgets calling for ever increasing reductions, Congress was reducing the budget even more.

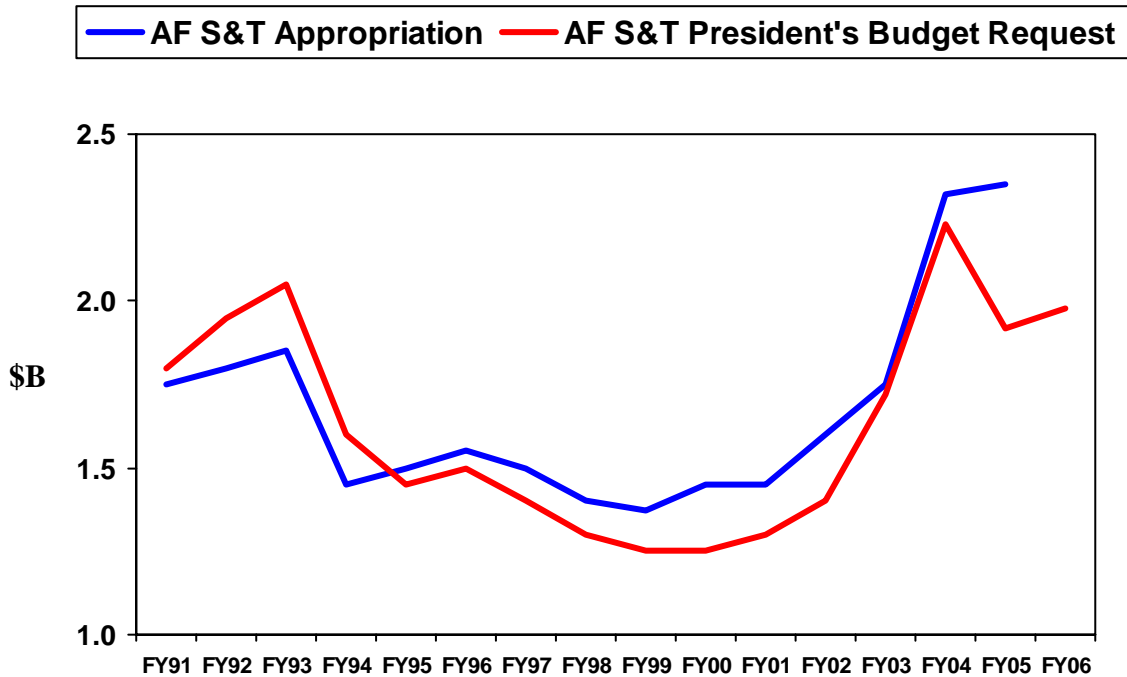

Figure 7. The President's Budget for USAF S&T and Congressional Appropriations

In FY 95, the situation reversed itself as Congress for the first time in years added more money than they took out of the President's budget. This reversal continued and, in fact, grew to record amounts in the following years. On the positive side, the Congressional additions served as clear notice to the Clinton and Bush administrations that the top line for Air Force S&T was going to be increased, and increased significantly. This obviously had an effect as the Bush administration, for the first time in nearly a decade, began submitting successive budgets calling for higher levels of defense S&T funding. It was also during this time that the administration stated its goal of funding DOD S&T at 3 percent of the total military budget.

On the negative side, the majority of the additions are in the program category that needs them the least—advanced technology development. The reason for this is fairly straightforward. Advanced technology development is almost exclusively performed under contract to the Air Force by industry, and industry is much more effective in lobbying Congress than any other element that performs Air Force S&T. These additions are not helpful in other ways as well. They typically do not reflect Air Force priorities, do

not adequately consider their place in the total Air Force S&T program, and sometimes do not sustain themselves with sufficient multi-year funding to finish the task. Perhaps even more importantly, they are creating even more of an imbalance between the basic and applied research aspects of the program (which is under funded by the administration) and the advanced technology development portion of the program (which is already over funded).

If the Air Force and the Department of Defense could reach agreement in shifting the S&T budget more toward basic and applied research as advocated in this paper, Congress must also be a willing partner. They as much as anyone must accept that the United States is far better served by a *stable*, balanced, adequately funded S&T program, and they must resist the temptation to make it otherwise.

*The SBIR Program.* The Small Business Innovative Research (SBIR) program of the Services is funded by taxing the research and development programs 2.5 percent of their extramural budget in excess of \$100 million. The amount currently allocated to SBIR by the Air Force is a substantial sum of money and now totals over \$300 million per year. The Air Force SBIR program is executed by the Air Force Research Laboratory, but the funding for it is not counted in the S&T top line. The Air Force has quite appropriately begun advocating limiting the amount of funding allocated to this program to \$250 million, or 2.5 percent of RDT&E funding, whichever is the lower amount.<sup>20</sup>

SBIR is a three-phase program. Phase I awards are for a period of six months with a maximum value of \$100,000. Phase II awards are for a maximum of two years with a maximum value of \$750,000. Only Phase I winners are considered for Phase II. A so-called Phase III also exists, during which the small business supposedly moves the results from Phase II into the market place, but this is not funded by the government, and essentially no records are available to assess it.

There are numerous difficulties with the SBIR program that are not specific to the Air Force. The vast majority of the money for the program comes from large development activities (e.g. F-22) but the performers of the work (small business) are encouraged to pursue more fundamental work (research). This results in mismatches of expectations and frequent dissatisfaction by the organizations that are contributing to the funding. The dollar values of the awards are relatively small, the timelines are relatively short, and there is no mechanism in place to track the products. This results in output of questionable value. The program also suffers from significant bureaucratic friction between OSD and the services. At best, the program could perhaps be described as a loose federation of research-related activities that are administered (not managed) by OSD and the services.

The Air Force would benefit from much stronger (and more active) management of its SBIR program. In spite of the significant funding allocated to the program, the strange

---

<sup>20</sup> Written response by the Air Force Deputy Assistant Secretary (Science, Technology and Engineering) to Senate Armed Services Committee, Question Number (SS-01-008), March 3, 2004.

mixture of funding sources, performing organizations, timelines, bureaucratic friction, and lack of a mechanism for measuring true success make this a very challenging task. The dollar amount has grown to such magnitude, however, that action must be taken.

*The IRAD Program.* The Independent Research and Development (IRAD) program, formulated and executed by industry, has almost no research content and little, if any, insight by the Federal Government. Nevertheless, it must be considered as a part of the overall investment in S&T by the Air Force. The dollar value of the total program by major defense contractors is perhaps on the order of \$3 billion per year, with about half of this recovered by industry as allowable charges to government contracts. For years, the focus of the program by industry has been on the short term, i.e. development and product improvement; almost none of the funding is invested in basic or applied research. It is reasonable to assume that approximately 30 percent (\$1 billion) of the annual DOD total is invested in Air Force relevant systems, and that perhaps 90 percent of this is invested in advanced development, or even more mature technology.

The above situation could change, but it would require voluntary shifts by industry (not likely) or legislation (even less likely). Given these facts, it is another reason that the Air Force should consider adjusting its S&T portfolio to achieve more balanced basic research/applied research/advanced technology development ratios. Industry relies heavily on its IRAD program, but the fact of the matter is that it is very much directed to the short term. The Air Force should take much better advantage of this by reducing its advanced technology development S&T funding and reinvesting this money in basic and applied research.

*The Impact of DARPA Programs.* DARPA involvement in, and support of, S&T programs of value to the Air Force is very important, very substantial, and very beneficial. However, as has been described previously in the cases of SBIR and IRAD, DARPA also has somewhat of a short-term (or at best a middle-term) focus. This length of focus results primarily from the DARPA informal policy of rotating program managers on roughly a three-year cycle. DARPA views itself as a change-agent, and rightly so. They are excellent at selecting technology areas of highly significant benefit to the military and demonstrating these technologies with very significant amounts of funding in realistic environments and scenarios. They are also very good at working with the service laboratories (especially the Air Force) in doing so.

The Air Force executes approximately \$500 million per year of DARPA funding in activities of mutual interest. In almost all of these activities, AFRL acts as an agent for DARPA and administers/manages the contractual and in-house activities that result, with the vast majority of the activities being contractual ones that are performed by industry. The single largest technical area of investment by DARPA in these activities is information technology/command and control. In addition, the Air Force benefits from perhaps another \$500 million in S&T activities that are directly managed by DARPA or are executed by the other services using DARPA funding.

*Highly Classified Programs.* This is obviously a difficult subject to discuss and will be addressed only briefly in this paper. It is reasonable to assume that some highly classified S&T activity is conducted that is not reported in the standard S&T line items in the annual President's budget. It is also probably safe to assume that none of this is basic research, and little or none is applied research. Finally, the funding levels for such activities, if they do indeed take place, are most likely relatively modest.

*The Impact of BRAC.* As of this writing, the impact of the Base Realignment and Closure (BRAC) Commission is an evolving story as it relates to Air Force S&T. Based on the submission of the BRAC Commission to the President, however, it does not appear that the proposed actions will have a significant, if any, impact on Air Force S&T funding.

# The Way Ahead

The current Air Force top line for science and technology is about right. It is very close (in adjusted dollars) to a figure that was called for by the Defense Science Board several years ago following a definitive analysis.<sup>21</sup> The budget now needs to be stabilized at this figure and adjusted only for inflation. Science and technology have long-term payoffs and will yield the best long-term payoffs if this relatively low-cost item in the Air Force budget is stable. However, how the funding is allocated among its various program element categories requires major adjustments in both the President’s budget and Congressional appropriations for Air Force science and technology. The Air Force and Congress have skewed the program in recent years to one that is entirely too top heavy in advanced technology development and entirely too deficient in basic and applied research. The following figure shows part of the problem.

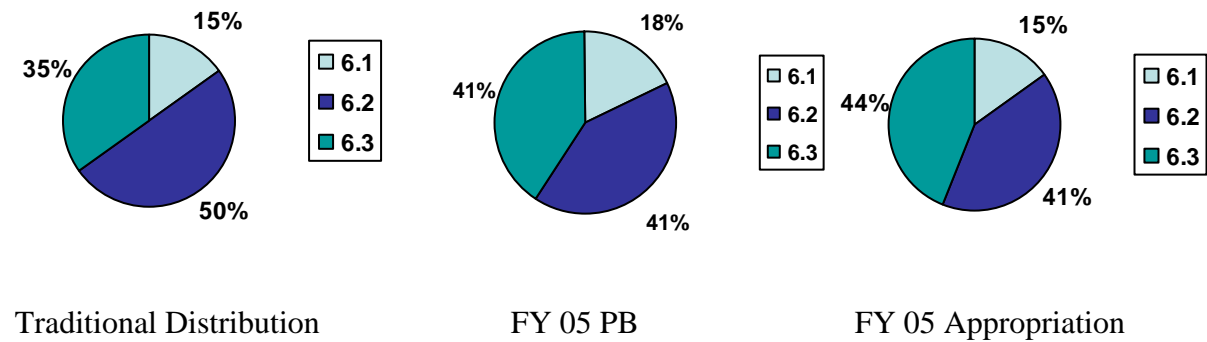

Figure 8. Air Force Basic Research, Applied Research and Advanced Technology Development Funding Distribution

As can be seen from figure 8, the percentage of funding appropriated for the combination of basic and applied research in FY 05 is now significantly reduced from the traditional amounts allocated for these categories. This distribution is further exasperated by the fact that nearly half of the funding indicated for basic research is not new money for the Air Force but rather a change in DOD accounting resulting from the FY04 OSD devolvement to the Services mentioned earlier.<sup>22</sup>

<sup>21</sup> Report of the Defense Science Board on Defense Science and Technology Base for the 21<sup>st</sup> Century, 30 June 1998.

<sup>22</sup> Then Under Secretary of Defense (Acquisition, Technology and Logistics) Mr. Pete Aldridge wanted to get his OSD staff out of the business of actively managing programs and thus instituted the “devolvement” strategy. Since most of the money devolved had passed from OSD to the Services in previous years after it was appropriated to OSD, this devolvement resulted in no net increase of Service S&T programs.

The proportions are even more skewed if the total amount of applied research and advanced technology development performed by others that directly benefits the Air Force is considered. Although it is impossible to get an exact accounting of this, figure 9 shows the approximate impact of adding Air Force SBIR and estimates of Air Force relevant IRAD and DARPA funding to the distribution. This “equivalent Air Force S&T funding” is clearly an improper imbalance and one that does not serve the nation well for the long term.<sup>23</sup> It also creates, at best, an unrealistic expectation of technology transition from the laboratory to the end user, because it is financially impossible to carry the majority of items now in advanced technology development into production. The money would be much better spent pursuing more, lower-cost options in basic and applied research, and choosing successful candidate technologies from these categories for advanced technology development.

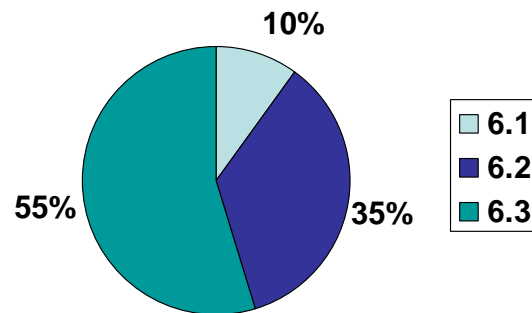

Figure 9. Current Equivalent Air Force S&T Budget

The budget categories that have been short-changed the most are basic research and the portion of applied research that AFRL conducts in-house. For the long-term well being of the Air Force and the nation, this must change. Earlier in this paper, Air Force funding of \$0.6 billion for basic research, \$1.2 billion for applied research, and \$0.5 billion for advanced technology development were advocated. Figure 10 shows how the equivalent Air Force S&T budget would look if these adjustments were made.<sup>24</sup> Clearly, a significant amount of the S&T activity is still in Advanced Technology Development, but a much more healthy allocation is given to research. The total basic research program is still very modest in relation to the other categories, especially Advanced Technology

<sup>23</sup> The “equivalent Air Force Science and Technology funding” is taken to be the appropriated 6.1, 6.2, and 6.3 amounts, plus \$300 million for SBIR distributed to 6.1 (\$50 million), 6.2 (\$200 million), and 6.3 (\$50 million); \$500 million from DARPA distributed to 6.2 (\$200 million) and 6.3 (\$300 million); and \$1 billion from IRAD distributed to 6.2 (\$100 million) and 6.3 (\$900 million).

<sup>24</sup> Again, the “equivalent Air Force Science and Technology budget” includes amounts from SBIR, DARPA and IRAD as indicated above.

Development, but this level of increase is vital if the Nation is to give the emphasis to an area that is long overdue. Likewise, the increase to Applied Research is relatively minor, but it will significantly increase the in-house ability and knowledge of the AFRL at a time when it is reshaping its workforce with younger scientists and engineers.

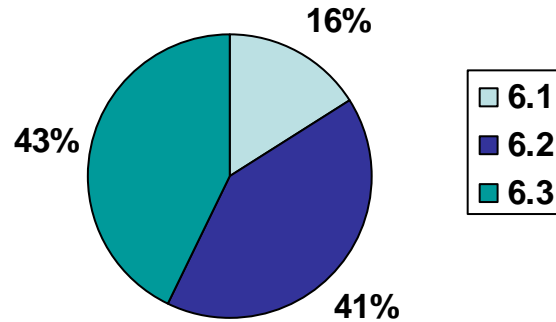

Figure 10. Proposed Equivalent Air Force S&T Budget

### S&T Areas to Emphasize and De-Emphasize

If the above adjustments are made, careful thought must be given to where new money will be invested in basic and applied research and where the Air Force funded advanced technology development program will be reduced. The basic research investment requires particular attention, and it seems at this time that at least three broad areas should be considered for additional funding: materials, propulsion, and computing.

Basic and applied research in materials for structures, materials for devices, and energetic materials should be dramatically increased. This research should not only take advantage of but should lead the national activities in nanotechnology and biotechnology. The research should also feature major partnership initiatives with the top-tier universities in the United States. A primary feature of these partnerships should be aggressive recruiting of graduate students by the universities to work on Air Force-sponsored research, with the idea that these same students will be recruited by AFRL to work in the Laboratory following the completion of their degree programs.

Fundamentally new propulsion concepts for air-breathing and rocket propulsion should be initiated. In addition, a major basic research initiative in propellants with the long-term goal of eliminating, to the maximum extent possible, Air Force dependence on fossil fuels should be started immediately. A parallel applied research program should be

initiated with the stated goal of improving specific fuel consumption by 50 percent for current turbine engines that use hydrocarbon fuels. Consumption of fuel continues to be the single largest logistics issue/requirement for the Air Force, and it must be improved. Air Force-funded turbine engine research and advanced technology development should be reduced dramatically, and the funding that is made available should be applied to the other areas mentioned here.

A major initiative in totally new computing concepts, such as quantum computing, should be started. The goal should be to increase speed and memory/storage by orders of magnitude. Significant attention should also be given to research in human/computer interaction for rapid decision-making coupled with improved cognitive performance of humans. In addition, major new work in control theory and communications research for very high density platforms (swarms) should be initiated.

In addition to reducing Air Force-funded advanced technology development in turbine engines, the Air Force 6.3 program should also be reduced significantly in sensors and information technology—areas that are highly funded by industry through their IRAD programs and by DARPA. All other Air Force-funded advanced technology development programs should be reduced, as well, (but more modestly) with the reductions invested in basic and applied research in their respective areas.

## **Concluding Thoughts**

Top line funding of Air Force science and technology is certainly not the issue it was several years ago; the top line is about where it should be. The next major issue that will soon confront the Air Force, however, is keeping it there. The Air Force and the nation would be far better served if the Air Force adopted a policy of level funding (adjusted only for inflation) S&T with a much stronger view toward the long term.

The distribution of Air Force S&T funding is dramatically out of balance. This is especially true when the equivalent S&T funding from all sources is considered. Going to a portfolio distribution that strongly favors basic and applied research for direct Air Force S&T funding must be done. Doing so will not only provide the vital balance for the long- and short-term aspects of the program, but, with strong leadership from government and industry, could actually provide a program that features more realistic expectations of results and products.