

UMTRI-71155

INFORMATION CENTER

HIGHWAY SAFETY RESEARCH INSTITUTE
INSTITUTE OF SCIENCE AND TECHNOLOGY
THE UNIVERSITY OF MICHIGAN

R ESEARCH
AND
E NGINEERING
FOR
A UTOMATION
AND
P RODUCTIVITY
IN
S HIPBUILDING

REAPS PROGRAM

Technical Memorandum 6047-6-008

FINAL REPORT:

FEASIBILITY OF FORMING TWIST
IN STRUCTURAL SHAPES FOR SHIPBUILDING

Transportation
Research Institute

S.Rajagopal

March, 1978

IIT Research Institute
10 West 35th Street
Chicago, Illinois 60616

Report Documentation Page

Form Approved
OMB No. 0704-0188

Public reporting burden for the collection of information is estimated to average 1 hour per response, including the time for reviewing instructions, searching existing data sources, gathering and maintaining the data needed, and completing and reviewing the collection of information. Send comments regarding this burden estimate or any other aspect of this collection of information, including suggestions for reducing this burden, to Washington Headquarters Services, Directorate for Information Operations and Reports, 1215 Jefferson Davis Highway, Suite 1204, Arlington VA 22202-4302. Respondents should be aware that notwithstanding any other provision of law, no person shall be subject to a penalty for failing to comply with a collection of information if it does not display a currently valid OMB control number.

| | | | | | |
|---|------------------------------------|-------------------------------------|--|--|---------------------------------|
| 1. REPORT DATE MAR 1978 | | 2. REPORT TYPE N/A | | 3. DATES COVERED - | |
| 4. TITLE AND SUBTITLE Feasibility of Forming Twist in Structural Shapes for Shipbuilding | | | | 5a. CONTRACT NUMBER | |
| | | | | 5b. GRANT NUMBER | |
| | | | | 5c. PROGRAM ELEMENT NUMBER | |
| 6. AUTHOR(S) | | | | 5d. PROJECT NUMBER | |
| | | | | 5e. TASK NUMBER | |
| | | | | 5f. WORK UNIT NUMBER | |
| 7. PERFORMING ORGANIZATION NAME(S) AND ADDRESS(ES) Naval Surface Warfare Center CD Code 2230 - Design Integration Tools Building 192 Room 128 9500 MacArthur Blvd Bethesda, MD 20817-5700 | | | | 8. PERFORMING ORGANIZATION REPORT NUMBER | |
| 9. SPONSORING/MONITORING AGENCY NAME(S) AND ADDRESS(ES) | | | | 10. SPONSOR/MONITOR'S ACRONYM(S) | |
| | | | | 11. SPONSOR/MONITOR'S REPORT NUMBER(S) | |
| 12. DISTRIBUTION/AVAILABILITY STATEMENT Approved for public release, distribution unlimited | | | | | |
| 13. SUPPLEMENTARY NOTES | | | | | |
| 14. ABSTRACT | | | | | |
| 15. SUBJECT TERMS | | | | | |
| 16. SECURITY CLASSIFICATION OF: | | | 17. LIMITATION OF ABSTRACT SAR | 18. NUMBER OF PAGES 53 | 19a. NAME OF RESPONSIBLE PERSON |
| a. REPORT unclassified | b. ABSTRACT unclassified | c. THIS PAGE unclassified | | | |

NSRP 0004

UMTRI
7#155

Report No. IITRI-H6047H01B01-5

FEASIBILITY OF FORMING TWIST
IN STRUCTURAL SHAPES FOR SHIPBUILDING

Prepared by

S. Rajagopal

IIT Research Institute
10 West 35 Street
Chicago, Illinois 60616

**Transportation
Research Institute**

24 March 1978

FOREWORD

UMTRI
71155

This report entitled "Feasibility of Forming Twist in Structural Shapes for Shipbuilding" represents the final report on the subject research carried out under auspices of the REAPS Program sponsored by the U.S. Department of Commerce, Maritime Administration under Contract Number 5-38072.

IIT RESEARCH INSTITUTE

TABLE OF CONTENTS

| | <u>Page</u> |
|--|-------------|
| 1. INTRODUCTION | 1 |
| 2. TECHNICAL DISCUSSION | 2 |
| 2.1 Analysis of the Twist Forming Process | 2 |
| 2.1.1 Twisting Moment and Total Twisting Angle Required | 2 |
| 2.1.2 Force Needed to Product Rotary Movement in Rocker | 8 |
| 2.2 Design of Rocker-Track Unit | 13 |
| 2.3 Cold Forming versus Hot Forming | 17 |
| 3. THE TWIST FORMING DIE SET. | 17 |
| 4. EXPERIMENTAL DETAILS | 29 |
| 4.1 Initial Experiments with Trial Sections | 29 |
| 4.1.1 Room-Temperature Forming | 29 |
| 4.1.2 Warm Twist Forming | 30 |
| 4.2 Twist Measurement | 32 |
| 4.3 Room-Temperature Twist Forming of Welded T-Sections. | 37 |
| 5. EXPERIMENTS WITH THE DOUBLE-ACTION DIE SET | 40 |
| 6. SUMMARY. | 47 |

LIST OF FIGURES

| <u>Figure</u> | | <u>Page</u> |
|---------------|---|-------------|
| 1 | Dimensions of Subscale T-Section, Scaled Down Linearly by a Factor of 5 from Full-Scale Dimensions. | 5 |
| 2 | Track-Rocker Behavior During Loading | 10 |
| 3 | Twist Forming Mechanism Showing Initial Positions of Press Platen, Coupler Bar, and Rocker and Their Final Positions after a 30° Rotation | 14 |
| 4 | Force-Displacement Curves Based on a Permanent Set of 3°/ft after Twisting through 30°. | 15 |
| 5 | Variation of Maximum Press Force with Friction | 16 |
| 6 | Schematic Illustration of Experimental Setup for Twist Forming Subscale T-Sections. | 18 |
| 7 | Track. | 20 |
| 8 | Rocker. | 21 |
| 9 | Coupler Bar. | 22 |
| 10 | Pivot Unit for Top End of Coupler Bar. | 23 |
| 11 | Framework for Supporting the Fixed End of the T-Section During Twisting. | 24 |
| 12 | Framework for Supporting Fixed End of T-Section, Shown Clamped to Press and Floor | 25 |
| 13 | Fixed-End Clamping Unit. | 25 |
| 14 | Rocker-End Clamping Unit | 26 |
| 15 | Modified Clamping Unit for Fixed End | 26 |
| 16 | Modified Clamping Unit for Rocker End. | 27 |
| 17 | Track Shown Mounted on Lower Platen of Press | 27 |
| 18 | Coupler Bar Connected at Top End to-Pivot Assembly | 28 |
| 19 | Fully Assembled View of Twist Forming Setup Shown Just Prior to Twisting | 28 |
| 20 | T-Section No. 2, Twist Formed at Room Temperature. | 31 |

LIST OF FIGURES (cont.)

| <u>Figure</u> | <u>Page</u> |
|---------------|--|
| 21 | two T-Sections That Were Twist Formed Warm. 33 |
| 22 | Four Views of Twist-Measuring Setup 34 |
| 23 | Principle of Twist Measurement for Subscale T-Sections. 36 |
| 24 | Three Welded T-Sections, Shown After Twist Forming. 38 |
| 25 | Two Views of Double-Action Twist Forming Die Set. . 41 |
| 26 | Double-Action Twist Forming, Caused by Rotation of Rockers in Opposite Directions When Press Moves Down.. . . . 42 |
| 27 | Front View of Twist Forming Setup in 75-Ton Press. (a) Before twisting; (b) after twisting 43 |
| 28 | Two Welded T-Sections, Shown After Double Action Twist Forming. 44 |

FEASIBILITY OF FORMING TWIST
IN STRUCTURAL SHAPES FOR SHIPBUILDING

1. INTRODUCTION

Large steel sections are used extensively as reinforcing structural members in the shipbuilding industry. T-sections, for example, often measure 30 in. x 1/2 in. in the web region and 10 in. x 1 in. in the flange region, and are over 40 ft long. These structural sections have to be twisted, with the toe of the web as the axis, to conform with the curving profile of the ship body. The twisting is generated primarily near each end of the section length, and is normally in the range of 1-2 °/ft with a maximum of about 3 °/ft. The current procedure employed for this purpose by Newport News Shipbuilding (NNS) involves heating each end of the section separately in a furnace to 1600°F, removing them, and then loading the end with a 4-5 ton dead load while using suitable positioned wedges. Once the setup is ready, it takes nearly 30-40 min per end with a five-man crew. The daily twist production rate is 10-12 ends/shift including setup time.

The objective of this venture was to investigate the feasibility of forming the twist, preferably at room temperature, using a set of forming dies in a hydraulic press. The structural T-sections were to be scaled down linearly by a factor of 5 to enable the experiments to be conducted in IITRI's 75 ton press. The main requirement on the twist was that it be accurate enough to allow joining of two consecutive members with as little mismatch as possible. Successful application of the twist forming technique would result in a higher production rate and elimination of heating furnaces and also the oxidation problem caused by heating to elevated temperatures, through the use of existing hydraulic presses (250, 1000, and 2500 ton capacities) at NNS.

The IITRI experiments served to demonstrate the feasibility of twist forming the members as outlined above. A die set was designed from analytical considerations of the mechanics of twist

IIT RESEARCH INSTITUTE

generation. Experiments were then conducted, first on trial sections fabricated from hot-rolled beams and then on welded subscale T-sections.

This final report describes the work performed under the subject venture, designated internally as IITRI-H6047H01B01, during the period May 1977-March 1978.

2. TECHNICAL DISCUSSION

2.1 Analysis of the Twist Forming Process

The die set used to generate twist in the subscale T-section consists essentially of a "track" and "rocker" unit. One end of the T-section is held fixed while the other is clamped to the rocker. The rocker is restricted to rotate within the track in an arc whose center of curvature is designed to coincide with the toe of the T-section web. The two main problems that had to be studied prior to designing the dies were

1. Calculation of the twisting moment and total angle of twist required to produce a desired "permanent set" in the subscale T-section, and
2. Press tonnage required to overcome rocker-track friction and T-section torsional resistance in generating the twist.

2.1.1 Twisting Moment and Total Twisting Angle Required

In this section a method is presented for calculating the twisting moment and total twisting angle required to produce a "permanent set" of 3° in a 1 ft length of T-section.

The twisting moment M_t required to produce a twist of θ_1 radians per inch in a rectangular section of width b and thickness t , and the maximum shear stress t_{max} in the section may be found using Prandtl's Membrane Analogy when $b \gg t$. For less narrow cross sections, Saint-Venant has found the solution by a more complicated method, whose results ⁽¹⁾ are shown in Table 1.

⁽¹⁾ J. P. Den Hartog, Advanced Strength of Materials, McGraw-Hill, New York, 1952, pp. 10-21.

Table 1

TWISTING MOMENT AND MAXIMUM SHEAR STRESS
DEVELOPED DURING TWISTING OF RECTANGULAR SECTIONS

| b/t | $\frac{t_{\max}}{(M_t/bt^2)}$ | $\frac{(M_t/\theta_1)}{Gbt^3}$ |
|----------|-------------------------------|--------------------------------|
| ∞ | 3.00 | 0.333 |
| 10 | 3.20 | 0.312 |
| 5 | 3.44 | 0.291 |
| 3 | 3.74 | 0.263 |
| 2 1/2 | 3.86 | 0.249 |
| 2 | 4.06 | 0.229 |
| 1 1/2 | 4.33 | 0.196 |
| 1 | 4.80 | 0.141 |

b = Width

t = Thickness

t_{\max} = Maximum shear stress

M_t = Twisting moment

θ_1 = Unit twist

G = Modulus of rigidity in torsion.

G represents the modulus of rigidity in torsion. These results can be used for "open" sections such as T shapes, I shapes, L shapes, and slit tubes but not for "closed" sections such as a hollow non-slitted tube. b is now interpreted as the total length of the web and the flange in the section. If in a structural section the flange and web are of different thickness, the twisting moment M_t has to be calculated separately for the web and the flange and added to give the total twisting moment for the entire section.

Figure 1 illustrates the section to be twisted.

$$\begin{aligned} b_1 &= 6 \text{ in.} & \frac{b_1}{t_1} &= 58 \\ t_1 &= 1/8 \text{ in.} \\ b_2 &= 2 \text{ in.} & \frac{b_2}{t_2} &= 8 \\ t_2 &= 1/4 \text{ in.} \end{aligned}$$

$$G = \text{modulus of torsional rigidity} = \frac{12 \times 10^6 \text{ psi}}{\text{for steel}}$$

Elastic Deformation

Suppose the section is given a uniform twist of

$$\begin{aligned} \theta_1 &= 1^\circ/\text{ft} \\ &= 0.001454 \text{ rad. per in.} \end{aligned}$$

Using Table 1 to find the stress and moment coefficients for the flange and web, separately we have

$$M_t = M_{t_1} + M_{t_2} \tag{1}$$

$$= 0.33 Gb_1t_1^3\theta_1 + 0.31 Gb_2t_2^3\theta_1 \tag{2}$$

$$= 5.6 \text{ ft-lb} + 14.1 \text{ ft-lb}$$

$$= 19.7 \text{ ft-lb}$$

$$\tau_{\max} = \tau_{1_{\max}} + \tau_{2_{\max}} \tag{3}$$

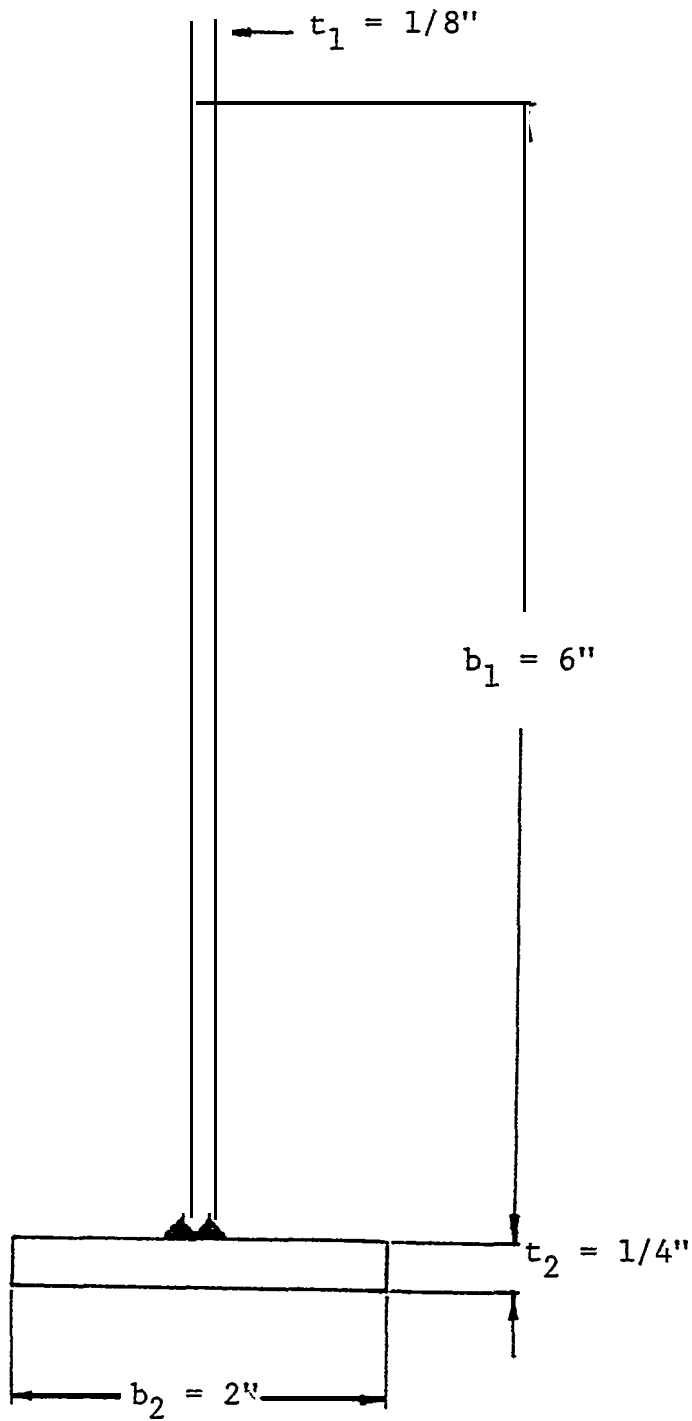

Figure 1

Dimensions of Subscale T-Section,
Scaled Down Linearly by a Factor of 5
from Full-Scale Dimensions

$$\begin{aligned}
&= \frac{3.0 M_{t_1}}{b_1 t_1^2} + \frac{3.3 M_{t_2}}{b_2 t_2^2} & (4) \\
&= 2150 \text{ psi} + 4467 \text{ psi} \\
&= 6617 \text{ psi}
\end{aligned}$$

This is lower than the expected yield stress in shear of $\tau_o = 35,000$ psi for 1080 H.R. steel. Consequently the 1°/ft twist is purely elastic, and the section will recover its original configuration upon loading.

Onset of Plastic Deformation

Let us now calculate the angle of twist needed to cause the onset of plastic deformation in the highest-stressed region. We have, as before

$$\tau_{\max} = \frac{3.0 M_{t_1}}{b_1 t_1^2} + \frac{3.3 M_{t_2}}{b_2 t_2^2} \quad (4)$$

where $M_{t_1} = 0.333 G b_1 t_1^3 \theta_1$

and $M_{t_2} = 0.30 G b_2 t_2^3 \theta_1$

Hence, $\tau_{\max} = 0.999 G t_1 \theta_1 + 0.990 G t_2 \theta_1$
 $\sim G \theta_1 (t_1 + t_2)$ (5)

Equating τ_{\max} to τ_o , the yield stress in shear, we can write the twist per unit length required to just produce yielding as

$$\begin{aligned}
\theta_1 &= \frac{\tau_o}{G(t_1 + t_2)} & (6) \\
&= 0.007778 \text{ rad. per inch} \\
&= 5.35^\circ/\text{ft}
\end{aligned}$$

Thus, a twist of 5.35°/ft causes the shear stress level in the highest-stressed region in the T-section (which, obviously, is

IIT RESEARCH INSTITUTE

the corner where the web and flange meet in the weld) to reach 35,000 psi at which point yielding begins to occur.

The twisting moment corresponding to this value of maximum shear stress will be 5.35 times the moment required for producing a 1°/ft twist

$$\begin{aligned}M_t &= (5.35) (19.7) \text{ ft-lb} \\ &= 105.4 \text{ ft-lb}\end{aligned}$$

Twist Forming in the Plastic Range

If we now wish to twist the section further so that upon unloading we are left with a "permanent set" of 3°/ft (0.004362 rad. per in.), we must know the behavior of the material in plastic shear before we can accurately determine the additional twisting moment required. However, a useful "upper bound" M_t^* can be found by assuming that the shear-stress vs. shear-strain curve follows the same slope, G , for the 3° additional twist. M_t^* is the twisting moment required to produce an elastic twist of $(5.35 + 3)^\circ/\text{ft} = 8.35^\circ/\text{ft}$ and will exceed slightly the actual twisting moment, which is that corresponding to an elastic twist of 5.35°/ft followed by a plastic twist of 3°/ft,

$$\begin{aligned}M_t^* &= (105.4 \text{ ft-lb}) (8.35/5.35) \\ &= 165 \text{ ft-lb (1980 in-lb)}\end{aligned}$$

This moment can be used as the design value of torque required to produce the desired twist in the subscale T-section.

Regarding the total angle of twist (elastic + plastic) that has to be imparted to the section so that a permanent set (plastic twist) of 3°/ft is left behind, if we assume that the material is elastic-perfectly plastic (non-strain hardening) we would need 8.35°/ft of which 5.35°/ft would be recovered (from Eq. 6) and 3°/ft would remain as a permanent set. However, some strain hardening is expected and so the total twist required would be somewhat higher. Since this was an unknown factor, the setup was designed to accommodate a total twist of 30°. (Experiments

later showed that when the T-section is twisted over a 9 in. length, about 15° ($20^\circ/\text{ft}$) twist is necessary to get a $3^\circ/\text{ft}$ permanent set.)

Full Scale Considerations

The same approach can be followed for the full-scale section. From Eq. 2, the twisting moment scaleup factor would vary **as the 4th power of the dimensional scaleup factor ($5^4 = 625$)**; from Eq. 4, the shear stress scaleup factor varies linearly as the dimensional scaleup factor (5), and the twisting angle scaleup factor, from Eq. 6, varies inversely as the dimensional scaleup factor ($1/5$). Thus, the angle of twist required for yielding is $1.07^\circ/\text{ft}$, the twisting moment corresponding to this angle of twist is 13,200 ft-lb, and the upper-bound twisting moment (M_t^*) for a $3^\circ/\text{ft}$ permanent set is 49,100 ft-lb. From experimental data for the subscale section, the total angle of twist required for the $3^\circ/\text{ft}$ set would probably be about $6^\circ/\text{ft}$ in the case of the full-scale T-section.

These results are summarized in Table 2:

2.1.2 Force Needed to Produce Rotary Movement in Rocker

Figure 2a shows a rocker partially supported by a track over a length l_2 from the center. The load F is applied at an **angle θ to the vertical and at a point on the rocker distant l_1** from the center. Let R be the radius of curvature of the rocker and track.

There are three different possibilities that can result from the application of F .

1. The rocker tilts about the point A (Fig. 2b)
2. No movement results (Fig. 2c).
3. The rocker rotates about O along the track (Fig. 2d) .

Table 2

RESULTS OF TWIST FORMING ANALYSIS
FOR SUBSCALE AND FULL-SCALE T-SECTIONS

| Section Size | Onset of Yielding | | 3°/ft Permanent Set | | | Press Force, ^b lb |
|-----------------|----------------------|------------------|---------------------|-------------------|-------------------------------|------------------------------------|
| | θ_1 , °/ft | M_t , ft-lb | Theoret- ical | Experi- mental | M_t , ^b ft-lb | |
| Subscale | 5.35 | 105.4 | 8.35 | 20 | 165 | 250 |
| Full-scale | 1.07 | 13,200 | 4.07 | 6 | 49,100 | 14,800 |

^a Theoretical = non-strain hardening; experimental = strain hardening.

^b See Section 2.1.2 for the frictionless ($\mu = 0$) case.

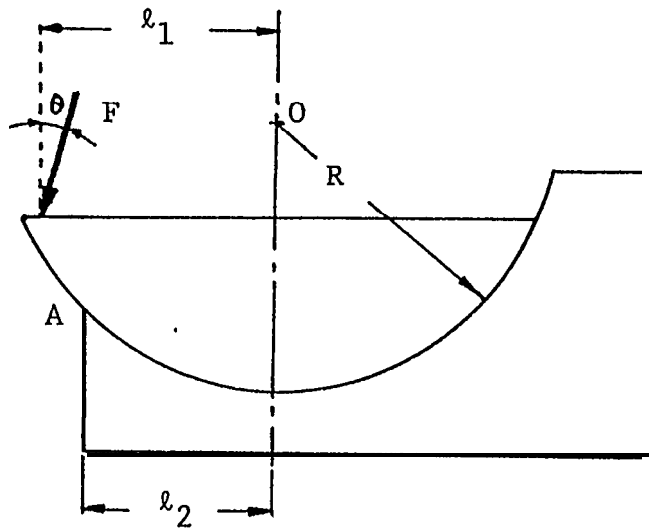

(a)

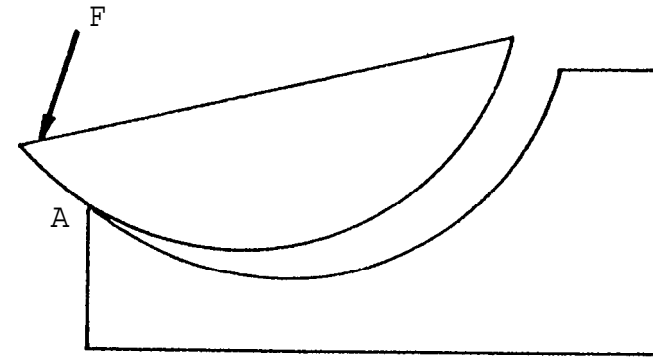

(b)

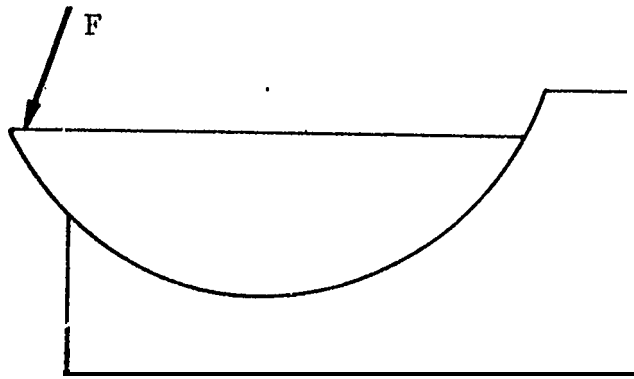

(c)

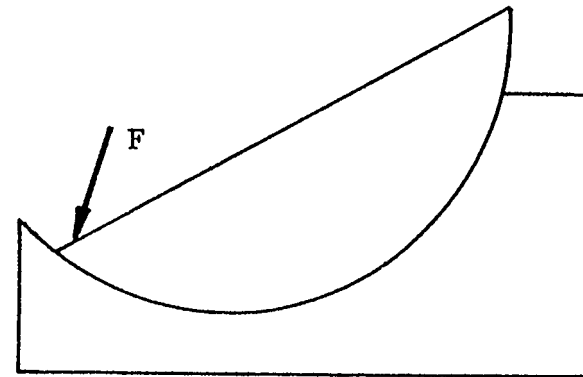

(d)

Figure 2

Track-Rocker Behavior During Loading. (a) Rocker on track and loaded by a force F at an angle θ ; (b) tilting caused by excessive overhang of rocker; (c) condition of no motion caused by insufficient magnitude of F ; (d) ideal rotary motion of rocker along track.

1. Tilting of the rocker about A will occur if the applied tilting moment about A ($F l_1 \cos \theta$) exceeds the sum of the resisting moments about A, i.e., $F l_2 \cos \theta + M_t$

where M_t = resistance of the structural section being twisted; i.e., for a given geometry, we must have

$$F < \frac{M_t}{(l_1 - l_2) \cos \theta} \quad (7)$$

i.e., the vertical component, $F \cos \theta$ of the applied force must never exceed the resistance to twist of the T-section divided by the overhanging length ($l_1 - l_2$). Obviously, if there is no overhang ($l_2 \geq l_1$), no finite magnitude of F can cause tilting.

2. Denoting the coefficient of static friction as μ_s , we can write the net resisting moment about the center of curvature as

$$M_R = M_t + (\mu_s F \cos \theta)R$$

The applied moment is

$$M_A = (F \cos \theta)l_1 - (F \sin \theta)R$$

If M_R exceeds M_A , then the condition of no motion will result, i.e., if

$$F \leq \frac{M_t}{l_1 \cos \theta - R (\sin \theta + \mu_s \cos \theta)} \quad (8)$$

we will have no movement.

3. If we wish to have proper rotary movement along the track, F must satisfy

$$\frac{M_t}{(l_1 - l_2) \cos \theta} > F > \frac{M_t}{l_1 \cos \theta - R (\sin \theta + \mu_s \cos \theta)}$$

By choosing $l_1 = l_2$, the maximum limit on F is removed. We can then write the force required to cause the rocker to rotate and produce twist in the T-section as

$$F = \frac{M_t}{l_1 \cos \theta - R (\sin \theta + \mu_s \cos \theta)} \quad (9)$$

The force required to keep the rocker in continued motion can be found by replacing μ_s with μ_d , the coefficient of dynamic friction.

It must be noted that when $l_1 \cos \theta = R (\sin \theta + \mu_s \cos \theta)$, i.e., when $\theta = \tan^{-1} [(l_1/R) - \mu_s]$, the force requirement becomes infinite. At this point the mechanism will lock and the force will build up in an unbounded fashion.

Sample Calculation

For the case of

$$R = 11 \text{ in.}$$

$$l_1 = 6 \text{ in.}$$

$$\theta = -12^\circ$$

$$F = \frac{M_t}{7.98 - 10.76\mu}$$

when $\mu = \frac{7.98}{10.76} = 0.817$ $F = \infty$ and locking occurs

For $M_t = 2000$ in-lb (see Section 2.1.1 for subscale section) the force required to rotate the rocker can be found for $\mu = 0$

as $F = 250$ lb

For $\mu = 0.60$, $F = 1312$ lb.

To calculate the press tonnage requirements for the full-scale section, we use $M_t = 49,100$ ft-lb (Section 2.1.1), and R and l values equal to 5 times the values used for the subscale section. Thus,

$$F = 14,800 \text{ lb (7.4 tons) when } \mu = 0, \text{ and}$$

$$F = 77,400 \text{ lb (38.7 tons) when } \mu = 0.6.$$

2.2 Design of Rocker-Track Unit

Prior to designing the individual components of the die set, some preliminary considerations were necessary to ensure compatibility of the system with the 75-ton press with respect to tonnage and stroke requirements. The stress analysis for the process (Section 2.1) showed that the forces required are well within the press capacity. The forming criteria developed in Section 2.1.2 provided a useful basis for designing the tooling.

Figure 3 is a mechanism-layout diagram showing the initial position of the press, arm (coupler bar), and rocker on the track, **and the rotation $\alpha = 30^\circ$ (max) of the rocker as the press moves down by $X = 4.38$ in. (max).** **The angle θ of force application** (see Section 2.1.2) remains nearly constant at -12° . This configuration was arrived at after a series of trials. These trials involved laying out the parts and optimizing the design to enable maximum rotation before the mechanism locks and prevents further movement.

On the basis of a linear increase in the twisting moment M_t from 0 to 2000 in-lb as the T-section is twisted from its initial position ($\alpha = 0$) to the final position corresponding to **$3^\circ/\text{ft}$ permanent set (say, at $\alpha = 30^\circ$)**, force-displacement curves were plotted (Fig. 4) for different coefficients of friction. The maximum force developed (at the end of the stroke) is shown plotted against the coefficient of friction at the rocker-track interface in Fig. 5. The expected coefficient of friction for our case is about 0.20,⁽²⁾ and the maximum force corresponding to this value is about 330 lb.

⁽²⁾ Charles Lipson, Wear Considerations in Design, Prentice-Hall, 1967, pp. 25-31.

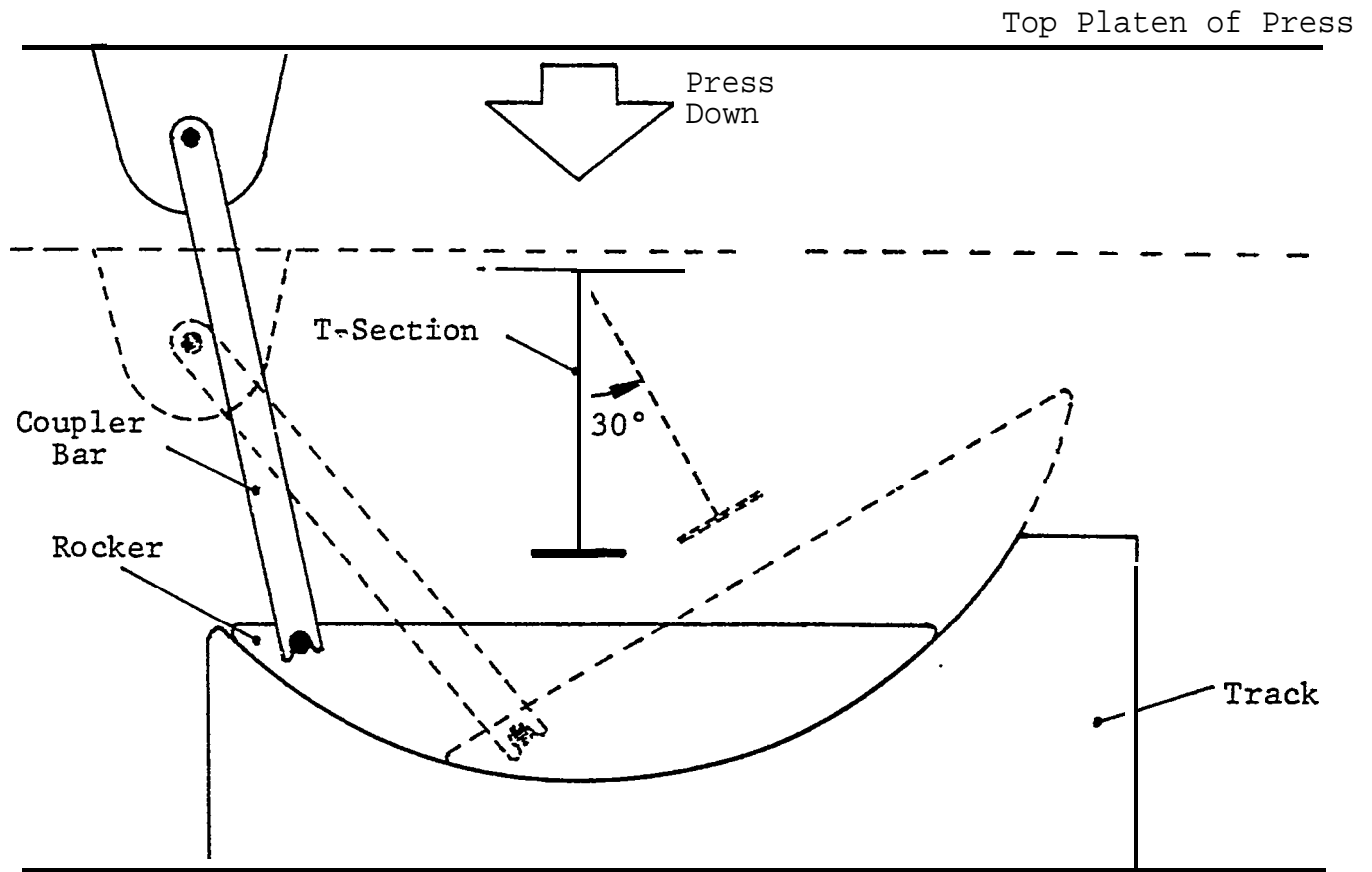

Figure 3

Twist Forming Mechanism Showing Initial Positions of Press Platen, Coupler Bar, and Rocker and Their Final Positions after a 30° Rotation (twist).

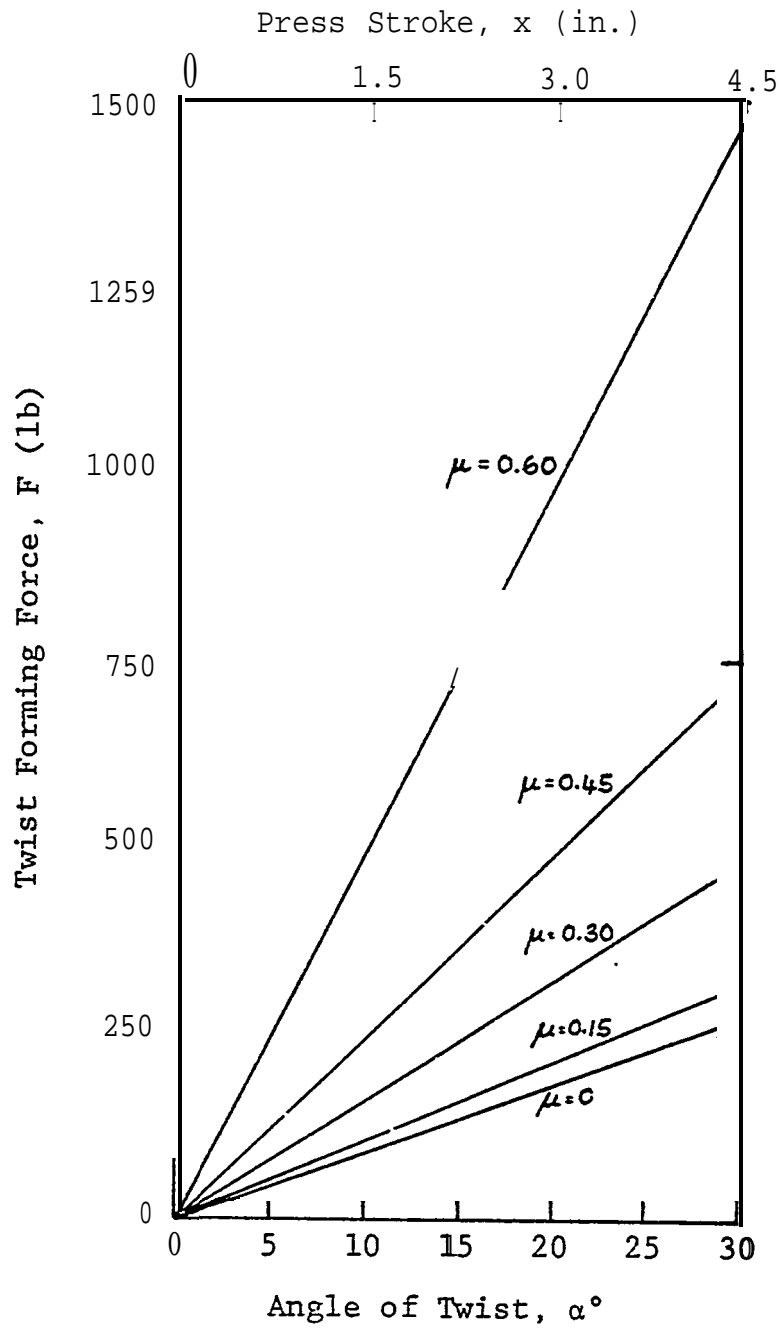

Figure 4

Force-Displacement Curves Based on a Permanent Set of $3^\circ/\text{ft}$ after Twisting through 30°

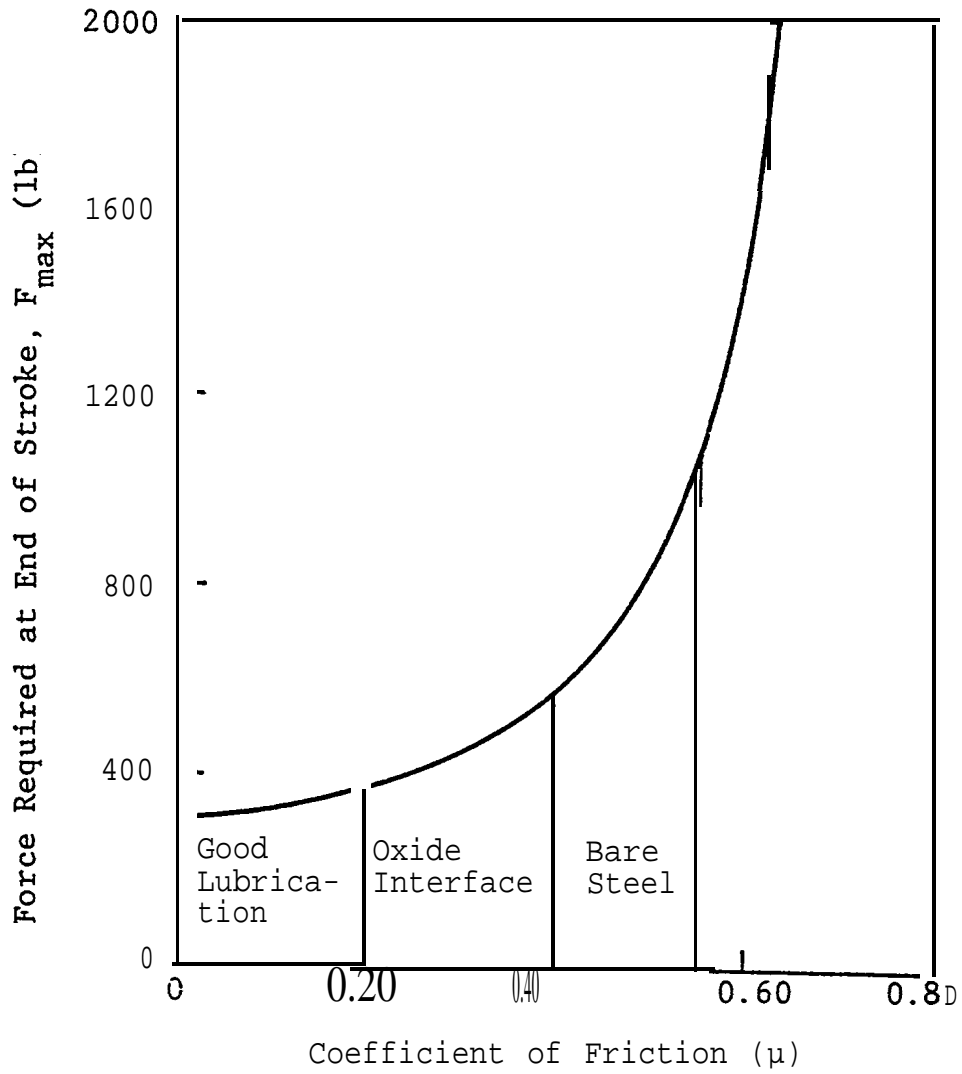

Figure 5

Variation of Maximum Press Force with Friction

2.3 Cold Forming versus Hot Forming

The reduced resistance to deformation of the material at elevated temperatures enables greater amounts of permanent set for a given degree of twist during forming. Also, press capacities are reduced and the tooling can be made smaller because of lower strength requirements. Another important advantage, which came to light during the initial experimental studies, was the reduction in lateral distortion of the twisted T-section when the process is conducted at warm temperatures. The problem of distortion during cold forming is the subject of later discussion (see Section 4).

Cold forming is desirable from the cost and performance points of view. Heating chambers are eliminated, and extra descaling and/or painting operations avoided. This lowers the equipment costs and setup times and results in higher production rates and reduced manufacturing costs. Furthermore, the strain-hardening effect of cold working increases the strength of the structural member (at the expense of some ductility), and its overall performance may be enhanced. For these reasons, cold twist forming was the main processing technique studied in this venture, while warm (intermediate temperature) forming was investigated briefly as a possible alternative.

3. THE TWIST FORMING DIE SET

The experimental setup, shown schematically in Fig. 6, consists of the T-section clamped at one end to a rigid framework by a pair of cast iron vises (later replaced by steel clamping devices) and at the other end of the rocker with another pair of vises. The rocker is nested in a track with a common center of curvature, this center being the toe of the T-section web. The toe of the web thus serves as the axis of twist during twist forming. A coupler bar, pinned at its upper end to a pivot assembly mounted to the top platen of the press and hooked at its lower end to one end of the rocker, provides rotary movement of the rocker on the track as the press is

IIT RESEARCH INSTITUTE

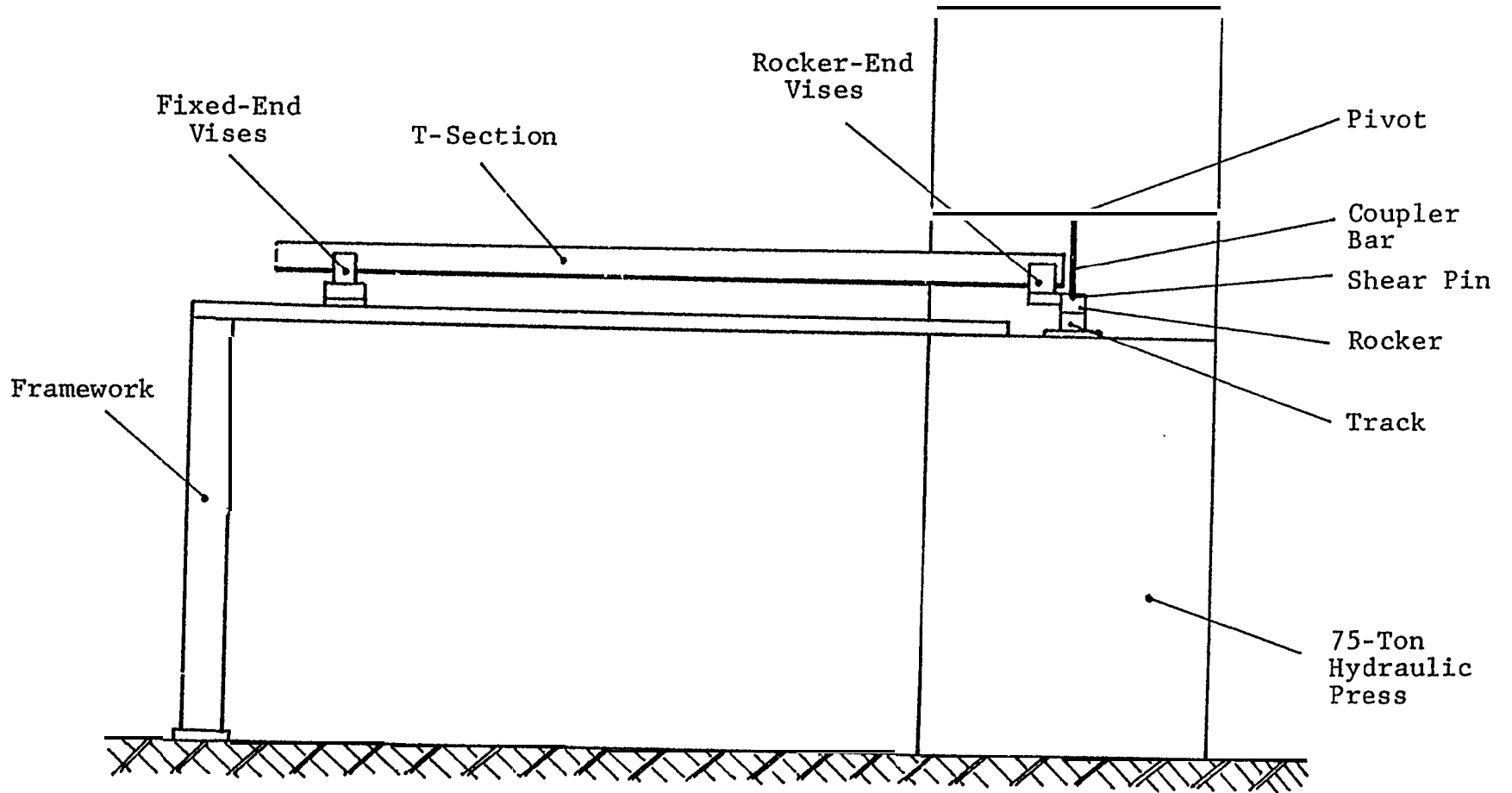

Figure 6

Schematic Illustration of Experimental Setup
for Twist Forming Subscale T-Sections

closed. This movement produces a twist in the T-section over the clamped length.

The pin in the rocker which the coupler bar hooks onto was designed as a shear pin with a maximum load-carrying capacity of 2000 lb. All other components of the die set were designed to carry over 3000 lb load. While the maximum force required for twisting the subscale T-section was expected to be only about 330 lb, mishaps leading to the rocker locking within the track could cause the load to build up to full press tonnage. A non-critical component (the shear pin) was therefore selected to fracture in such a situation, to ensure safe operation of the major components of the die set under all conditions. Figures 7 to 11 are drawings of these components.

The rigid framework is attached to the hydraulic press, as shown in Fig. 12, with two 3/4-10 bolts to fasten it at its forward end to the lower platen of the press, and two more 3/4-10 bolts to anchor the aft end to the floor, preventing lift-off during, twisting.

The two vises and the mounting plate that constitute the fixed end clamping unit are shown mounted on the framework in Fig. 13. The clamping unit for the free (rocker) end is shown in Fig. 14. It is welded to the rocker at a location such that the jaws of both pairs of vises are at the same level when assembled.

During the early trials, the cast iron vises were found to possess inadequate strength. The welds joining the vises to the mounting plates were particularly weak and fractured repeatedly. Hence, an all-steel clamp design was chosen to replace the original unit. The modified clamps for the fixed end and the rocker end are shown in Figs. 15 and 16, respectively.

The track is mounted on the lower platen of the press, as shown in Fig. 17. Finally, the pivot-assembly is bolted to the top platen (Fig. 18).

Material: 1020 H.R. Steel
All dimensions in inches
Scale: 1/4

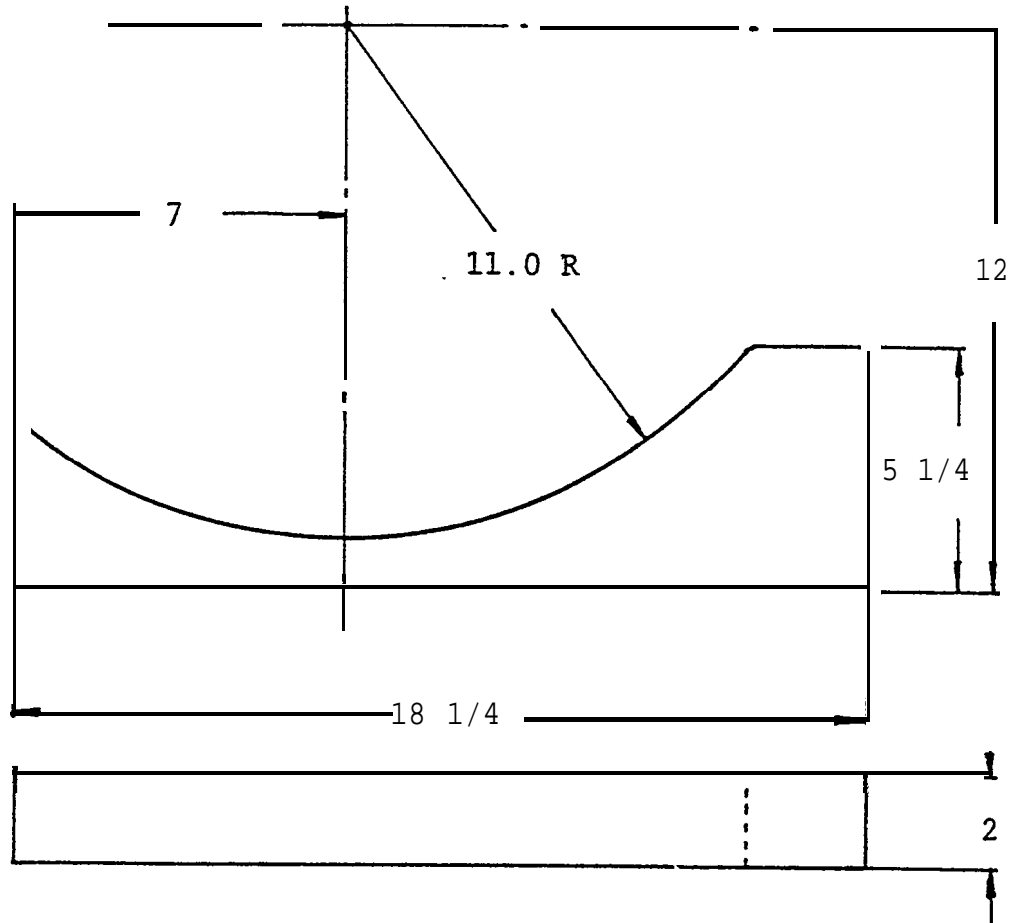

Figure 7
Track

Material: 1020 H.R. Steel
All dimensions in inches
Scale: 1/4

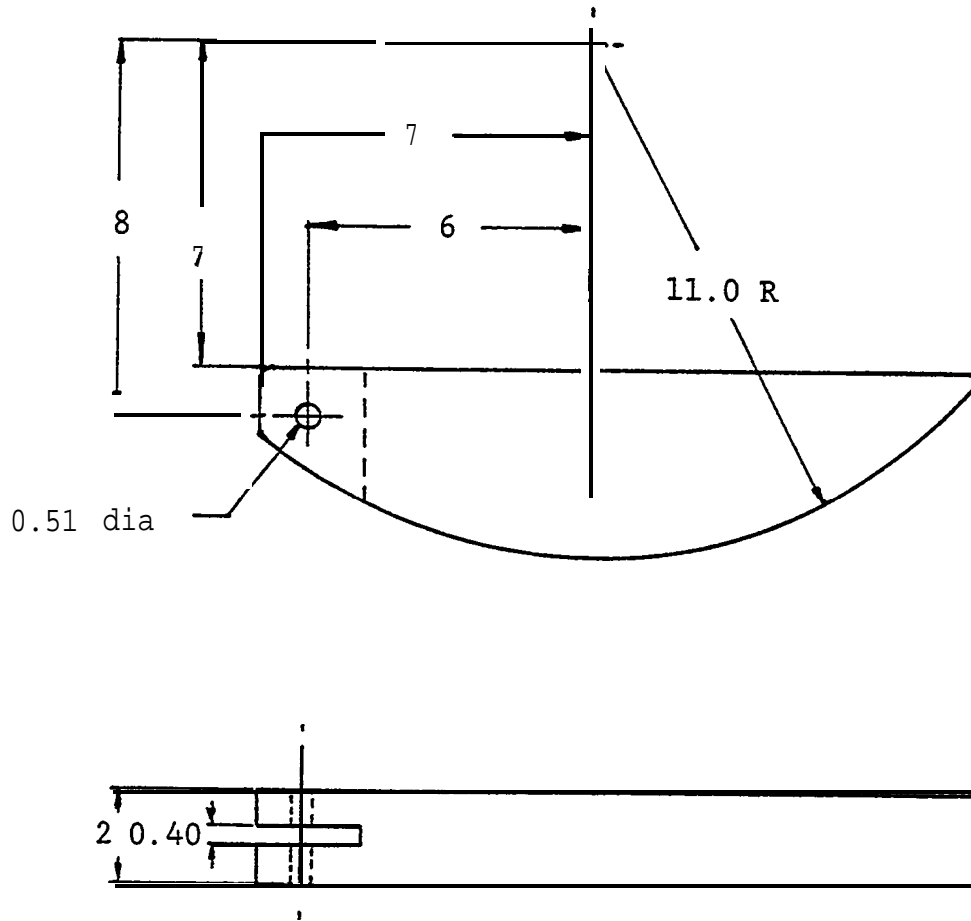

Figure 8
Rocker

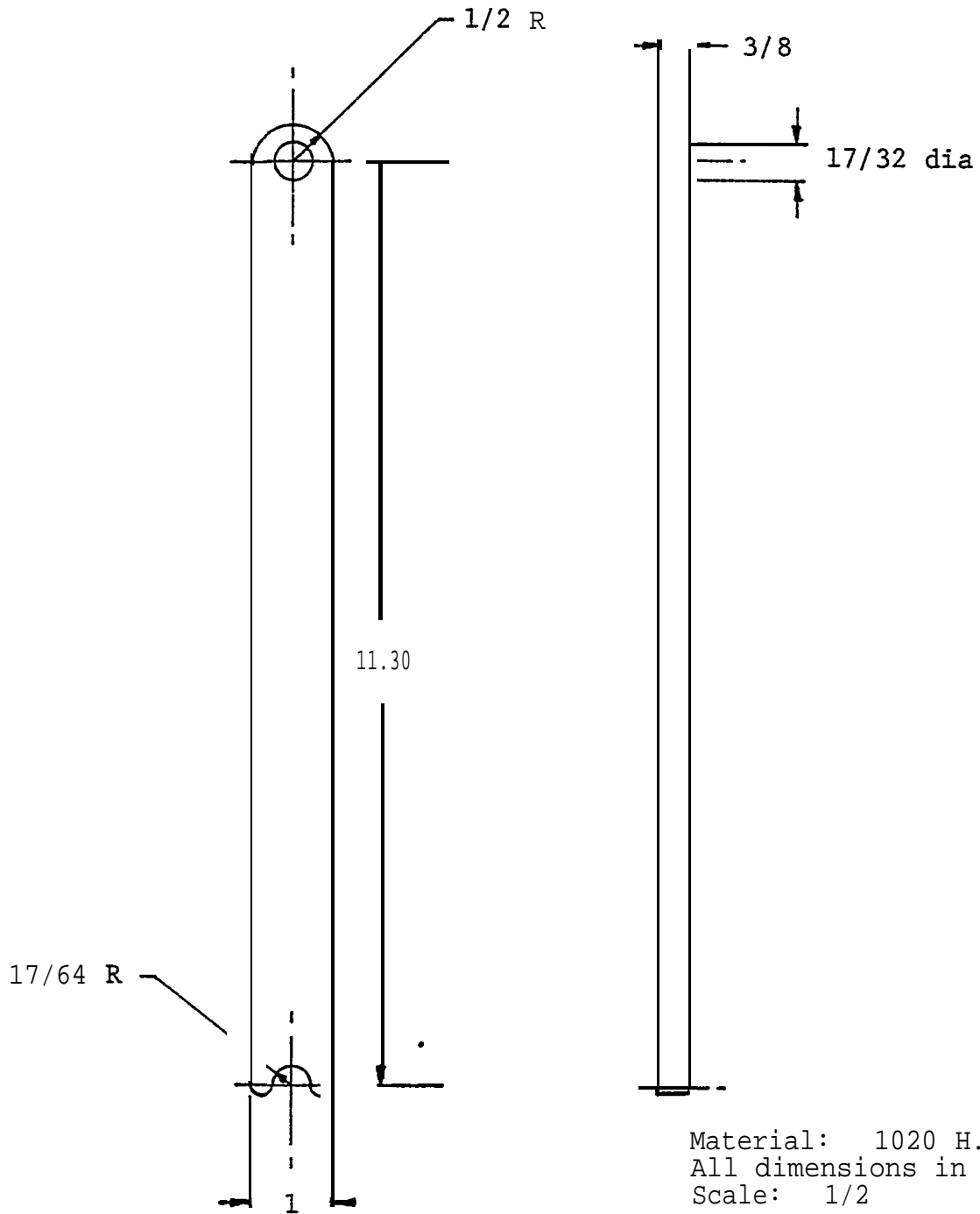
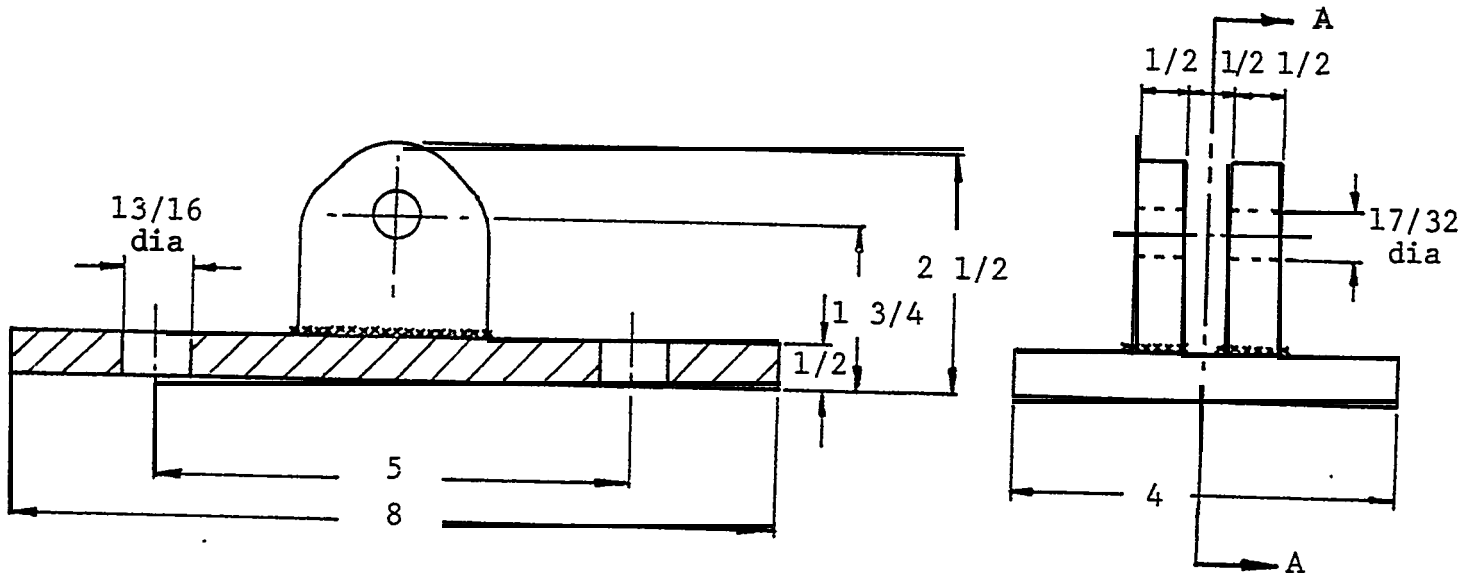

Figure 9
Coupler Bar



Material: 1020 H.R. Steel
 All dimensions in inches
 Scale : 1/2

Figure 10
 Pivot Unit for Top End of Coupler Bar

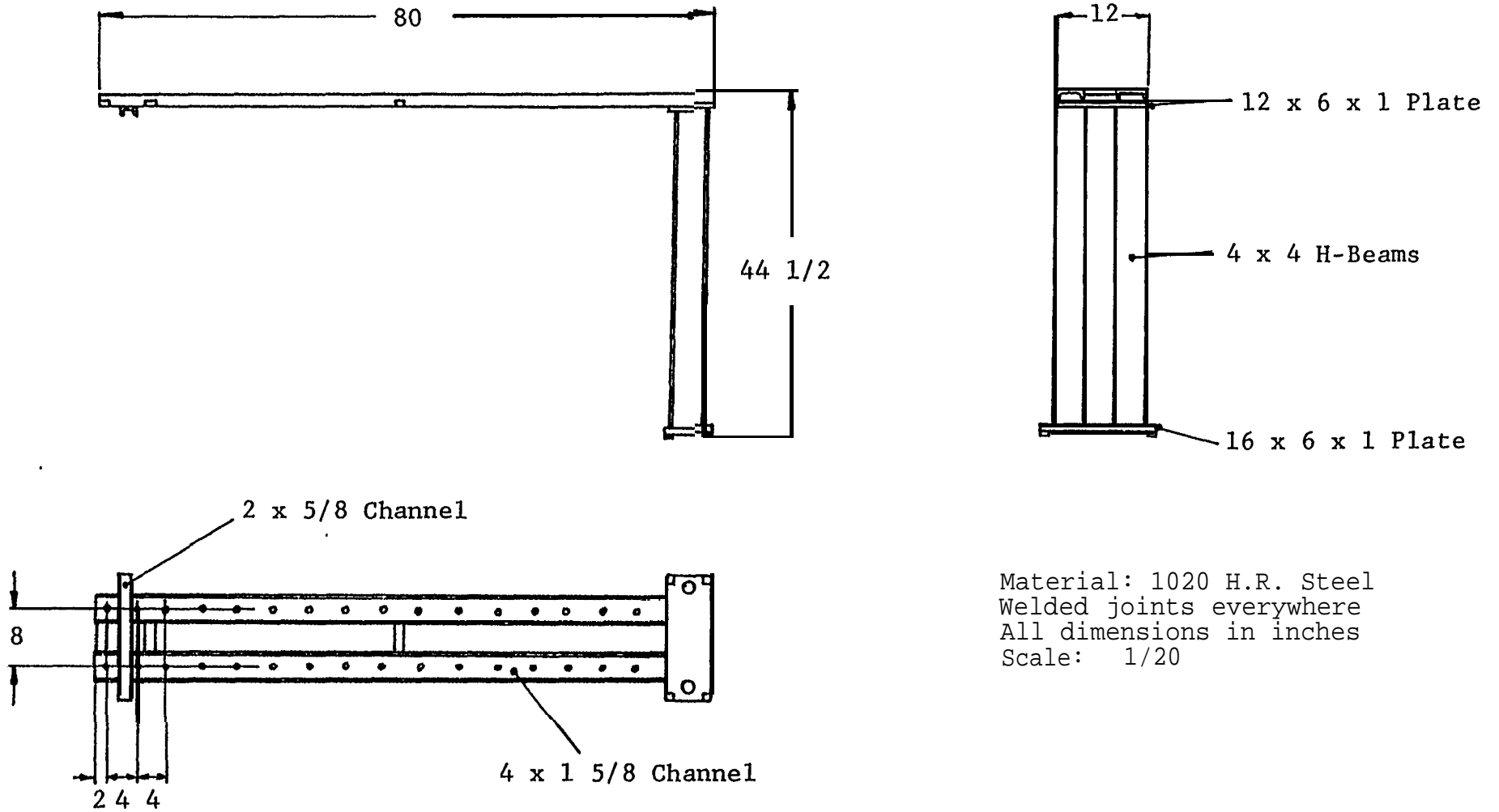

Figure 11

Framework for Supporting the Fixed End
 of the T-Section During Twisting



Neg. No. 46586

Figure 12

Framework for Supporting Fixed End
of T-Section, Shown Clamped
to Press and Floor.

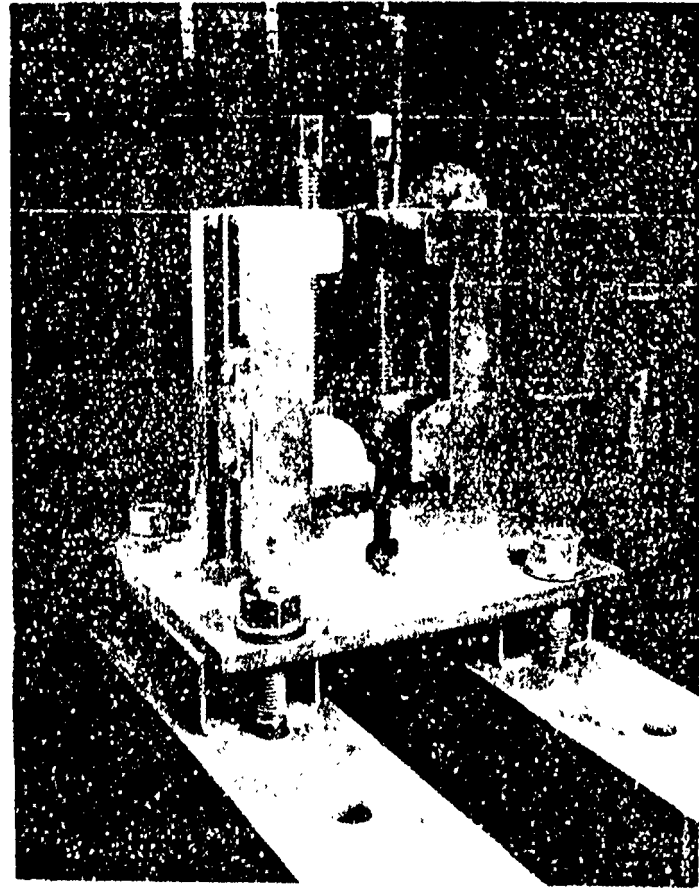

Neg. No. 46587

Figure 13

Fixed-End Clamping Unit

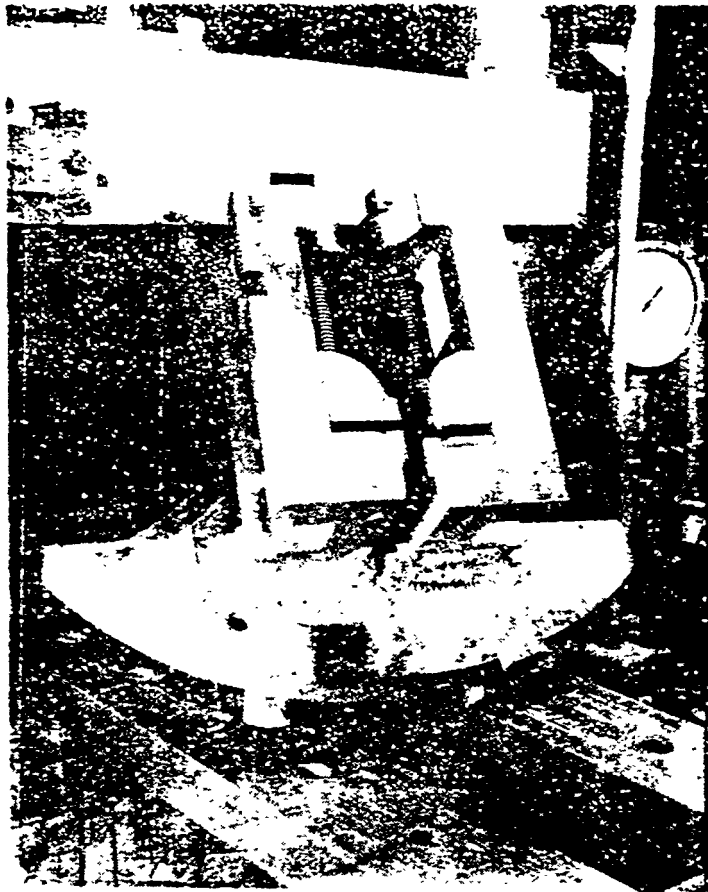

Neg. No. 46588

Figure 14

Rocker-End Clamping Unit

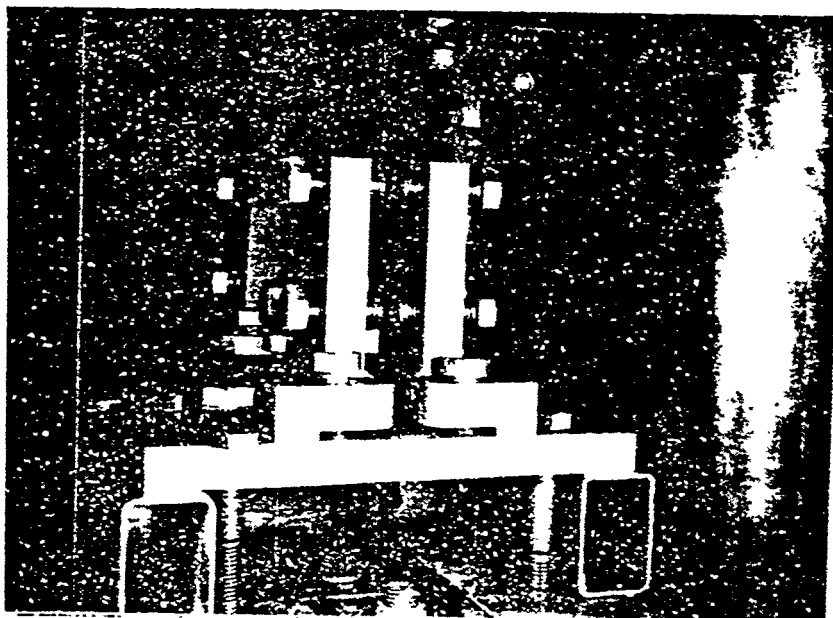

Neg. No. 47390

Figure 15

Modified Clamping Unit for Fixed End

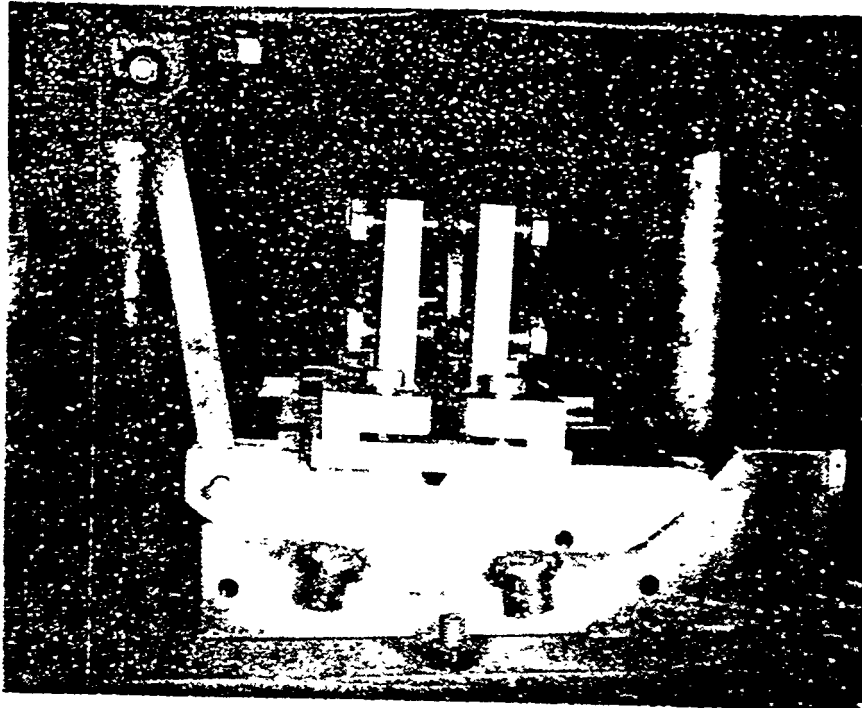

Neg. No. 47389

Figure 16
Modified Clamping Unit for Rocker End

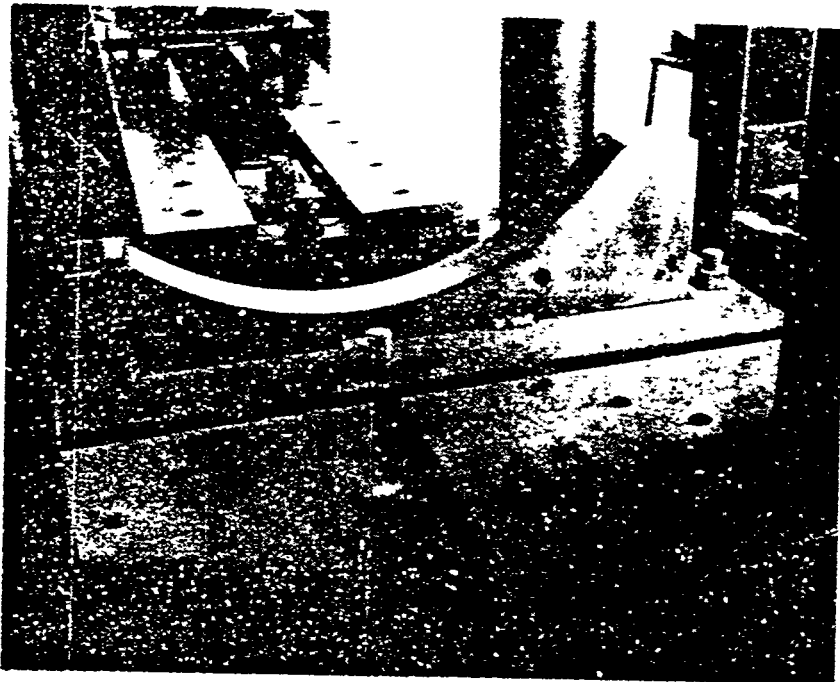

Neg. No. 46589

Figure 17
Track Shown Mounted on Lower Platen of Press



Neg. No. 46590

Figure 18

Coupler Bar Connected at Top End
to Pivot Assembly

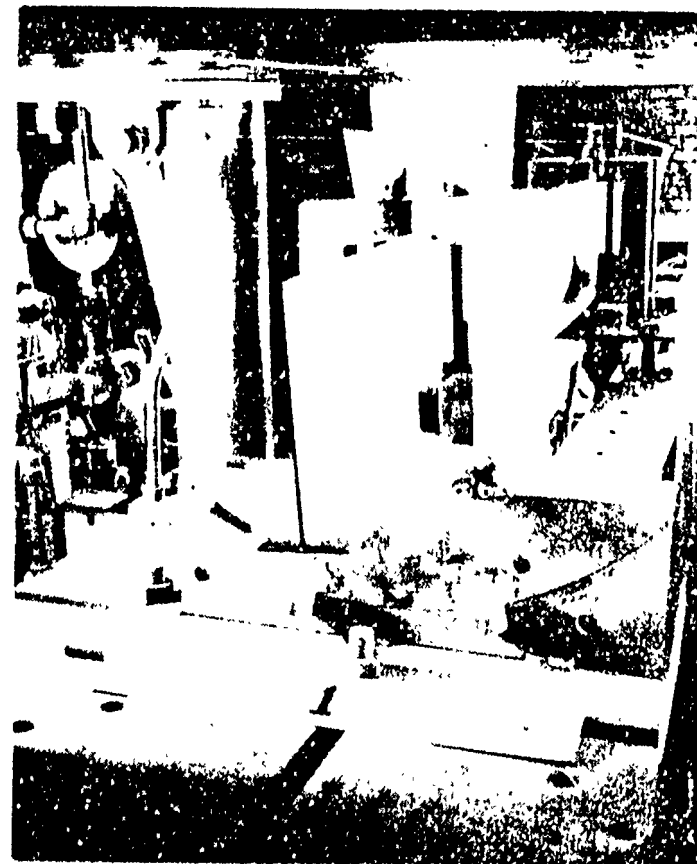

Neg. No. 46594

Figure 19

Fully Assembled View of Twist
Forming Setup Shown Just Prior
to Twisting

Figure 19 shows the overall assembly in the 75-ton press as it would look just prior to an experimental run.

4. EXPERIMENTAL DETAILS

4.1 Initial Experiments with Trial Sections

The initial optimization experiments were conducted using lightweight structural I-beams, 5-6 ft in length, with one of the flanges machined off to result in a makeshift T-section. The selection of the I-beam for this purpose was made so as to approximate, as closely as possible, the geometry of the sub-scale T-section. The dimensions of the machined section used for the initial trials are shown below in comparison with the actual target dimensions.

| | <u>Trial Section</u> | <u>Target Section</u> |
|---------------|----------------------|-----------------------|
| <u>Flange</u> | | |
| Width | 2.28 in. | 2 in. |
| Thickness | 0.196 in. (avg) | 0.25 in. |
| <u>Web</u> | | |
| Height | 6 in. | 6 in. |
| Thickness | 0.135 in. | 0.125 in. |

4.1.1 Room-Temperature Forming

The T-section and all items of tooling were first assembled in the press as shown earlier in Fig. 19. The coupler bar was then engaged in the rocker shear pin, and the press was moved down to rotate the rocker and generate twist in the T-section. The rocker was calibrated to read the twist (in °) during forming. When a predetermined angle of twist was reached, the press was retracted and the T-section was removed from the setup and examined for signs of permanent twist.

It was observed that when the twist zone is about 2 ft, i.e., the fixed end clamps and rocker" end clamps are about 2 ft apart, and when the angle of twist during forming is about 30° (maximum attainable movement), the T-sections completely recover their original configuration. In order to induce plastic

IIT RESEARCH INSTITUTE

deformation, the clamps were brought closer together to result in a twist zone of only 8 in. The T-sections were clamped tightly and twisted through 20°. This resulted in a barely discernible permanent twist, but what was more readily apparent was the fairly severe transverse bending of the section (Fig. 20).

The twist forming parameters were later optimized to alleviate this form of transverse bending. The length of the twist zone, the clamping torque, and the degree of twist were all found to play a role in limiting the bending of the T-section during twist forming. For room-temperature forming of the trial sections, best results were obtained when the sections were clamped with only moderate tightness over a span (twist zone) of 4-3/4 in. and twisted through 11°. A uniform twist of about 4°/ft was obtained under these conditions.

4.1.2 Warm Twist Forming

Warm forming was considered as a possible method of eliminating the transverse bending problem encountered during the early twist forming experiments conducted at room temperature. Towards this end, warm twist forming was fairly successful and--under the same conditions of twist zone length, clamping torque, and twisting angle--resulted in more uniform twists with a greater magnitude of permanent set and with a significant reduction in transverse bending. However, similar results were later obtained in room-temperature forming itself through proper control of process parameters (Section 4.1.1). Warm twisting was thus no longer necessary.

Two T-sections were twist formed at warm temperature. The procedure employed for warm forming is as follows:

The T-section was clamped in the vises with only moderate tightening force, and the web-clamping bolts were merely hand-tightened. The twisted length was kept at 14 in. This zone was preheated, using an oxyacetylene torch, to a temperature of 600°F for one T-section (No. 3) and 450°F for the other (No. 4)--and then twisted through about 15°. The press was then retracted,

IIT RESEARCH INSTITUTE



Neg. No. 46771

Figure 20

T-Section No. 2, Twist Formed at Room Temperature.
Note the lateral bending near the center,

the vise clamps were loosened, and the T-section was pushed through till the next zone of twist fell between the clamps. This zone was also preheated and twisted by the same amount. There were three zones of twist in all--each 14 in. in length.

The entire process worked satisfactorily for both T-sections. No. 3, which was twisted at 600°F had a 5.1°/ft average permanent twist while section No. 4, which was twisted at 450°F, had a 2.1°/ft average permanent twist. It was observed that No. 3, despite the higher temperature used, had a greater lateral curvature than No. 4. Apparently, the greater magnitude of twist generated in the case of the former more than offset the beneficial effects of the higher temperature. No. 4 was twisted only moderately to result in a smaller degree of permanent twist as well as a smaller amount of undesirable curvature. These results are illustrated in Fig. 21.

4.2 Twist Measurement

The twist-measuring setup consists of a precision granite table and a dial gage mounted on a Vernier height gage. It is shown in Fig. 22 along with the T-section whose twist was being measured.

Prior to twisting, marks were scribed on the flanges of the T-sections at the measuring stations shown in Fig. 23. The twist was measured both before twisting and after, and the total twist generated was calculated according to the formula in Fig. 23.

Measurements were taken by moving the dial gage along the length of the flange, as shown in Fig. 22. The height readings were recorded at each station ($h_1, h_2, h_3, \dots, h_1^*, h_2^*; h_3^* \dots$) from which the unit twist, a , was readily computed.

The accuracy of this measuring technique is about $\pm 1^\circ/\text{ft}$. Consequently, it could not be used to generate a reliable twist profile along the length of the sections. However, it was possible to get an accurate average unit twist from the heights measured at the extreme end stations of the twisted T-section.

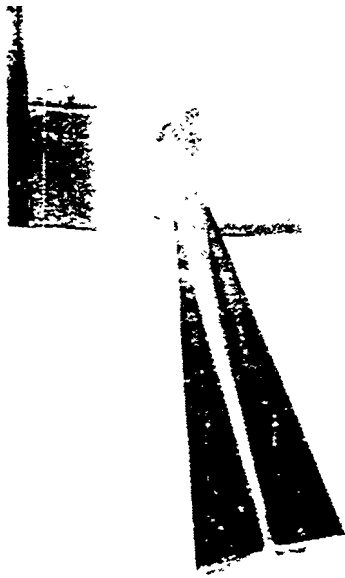

Neg. No. 46772
(a)



Neg. No. 46773
(b)

Figure 21

Two T-Sections That Were Twist Formed Warm.
(a) No. 3, formed at 600°F by 5.1 °/ft;
(b) No. 4, formed at 450°F by 2.1 °/ ft.

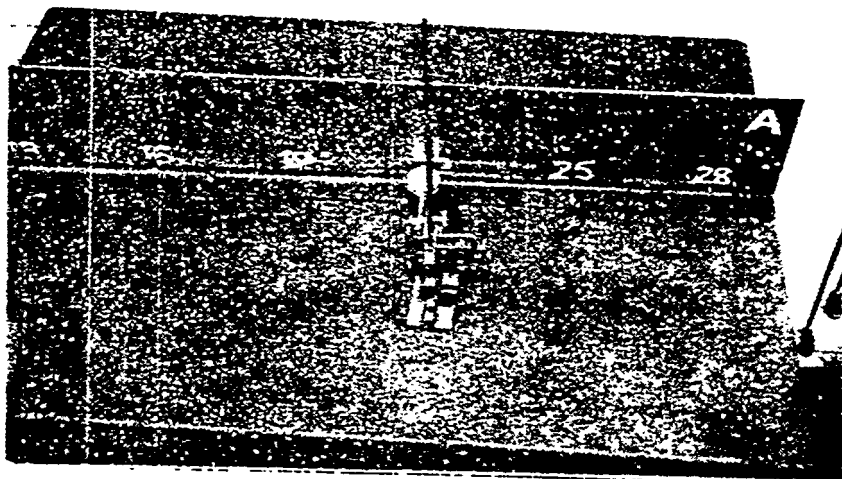

Neg. No. 46765

(a)



Neg. No. 46766

(b)

Figure 22.

Four Views of Twist-Measuring Setup

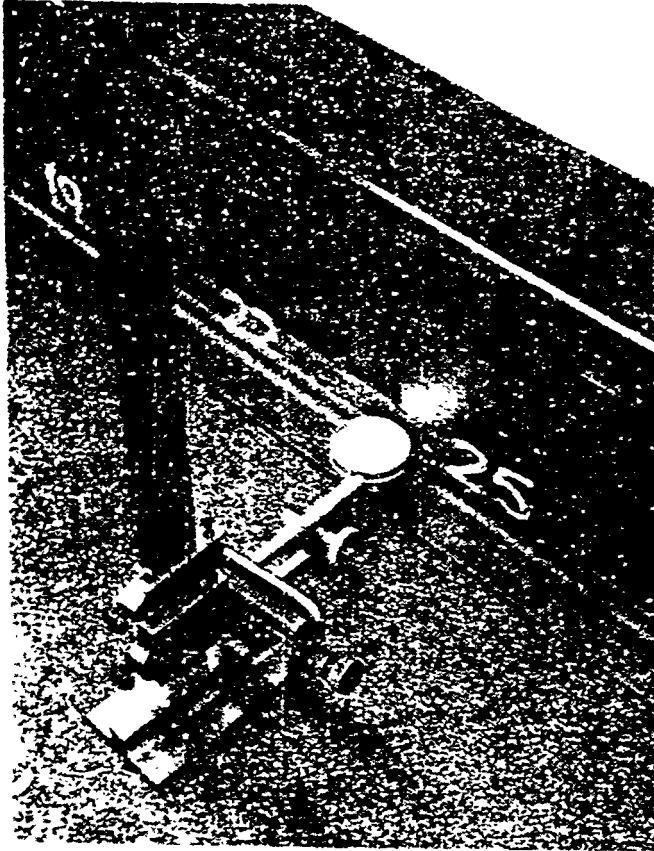

Neg. No. 46767

(c)



Neg. No. 46768

(d)

Figure 22 (cont.)

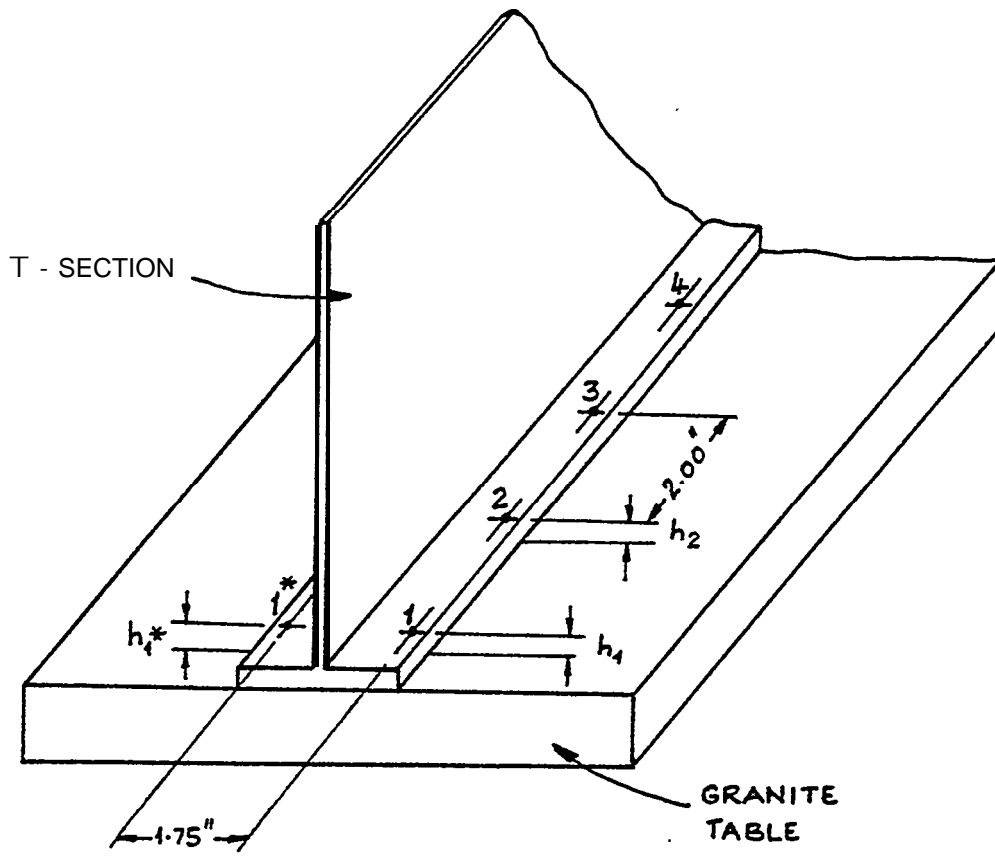

1, 1*, 2, 2*, etc. TWIST-MEASURING STATIONS

α_{1-2} = UNIT TWIST ($^{\circ}$ /ft) BETWEEN STATIONS 1 AND 2

$$= 6 \left[\tan^{-1} \left(\frac{h_2^* - h_2}{1.75} \right) - \tan^{-1} \left(\frac{h_1^* - h_1}{1.75} \right) \right]$$

($h_1, h_1^*,$ etc. in inches)

Figure 23

Principle of Twist Measurement for Subscale T-Sections

4.3 Room-Temperature Twist Forming of Welded T-Sections

T-sections were fabricated from 1010 carbon *steel* strips by GTA welding using Oxweld 65 welding rods. Three of these were twist formed at room temperature following the same procedure that had been employed earlier for the trial sections. It was observed that these sections were softer and less resilient than the trial sections, and consequently retained greater amounts of permanent twist with less lateral bending or distortion.

Process parameters were optimized as before to result in distortion-free sections after twisting. The length of the twist zone and the angle of twist that were found to give best results were 9 in. and 12° , respectively.

The three welded T-sections are shown after twist forming in Fig. 24. Table 3 summarizes the results of these tests,



Neg. No. 47959

Neg. No. 47960

Neg. No. 47961

Figure 24

Three Welded T-Sections, Shown After Cold Twist Forming

Table 3

TWIST FORMING RESULTS FOR WELDED T-SECTIONS

| <u>T-Section No.</u> | <u>Length of Twist Zone, in.</u> | <u>Permanent Unit Twist, °/ft</u> | <u>Overall Length of T-Section, ft</u> |
|--------------------------|--|---|--|
| 9 | 9 | 2.0 | 9.5 |
| 12 | 9 | 2.2 | 8.5 |
| 13 | 9 | 2.3 | 12.0 |

5. EXPERIMENTS WITH THE DOUBLE-ACTION DIE SET

As mentioned earlier, severe cold twist forming of T-sections invariably left behind a permanent lateral bending in the section. While it was possible to control and occasionally even eliminate the bending by suitably adjusting the length of the twist zone and the magnitude of twist imposed on the section, it was found that most cold twisted sections retained some measure of lateral curvature in the toe of the web. However, by feeding the twisted section into the twist forming apparatus backwards, i.e., with the last-formed zone now being twisted first, the bending was made to occur in the opposite direction while the twisting was still in the same direction as before. This procedure was used to take out the bend in two of the T-sections twist-formed earlier.

The double twisting procedure as outlined above is quite cumbersome and would reduce considerably the twist production rate. The apparatus was, therefore, modified to produce the same effect through one "double-action" twist. An identical set of twist forming dies was made and assembled in the press back-to-back with the existing set. The spacing was adjusted to result in a 9 in. zone of twist. The modified setup is shown, together with the clamped T-section, in Fig. 25.

When the press is moved down, the two coupler bars engage in their respective rockers. The rockers rotate in opposite directions in their tracks relative to each other (Fig. 26). This double-action twist forming produces a purer form of twisting than was possible before with the single-action die set wherein only one end of the section was free to rotate. Figure 27 shows a front view of the setup before and after twisting.

Two welded T-sections were successfully cold twist formed using the double-action twist forming dies--the first by 6°/ft and the second by 3°/ft. In both cases, the toe of the web was very straight (Fig. 28) except near each end where small amounts of curvature were observed. It is believed that any slight



Neg. No. 48005

(a)

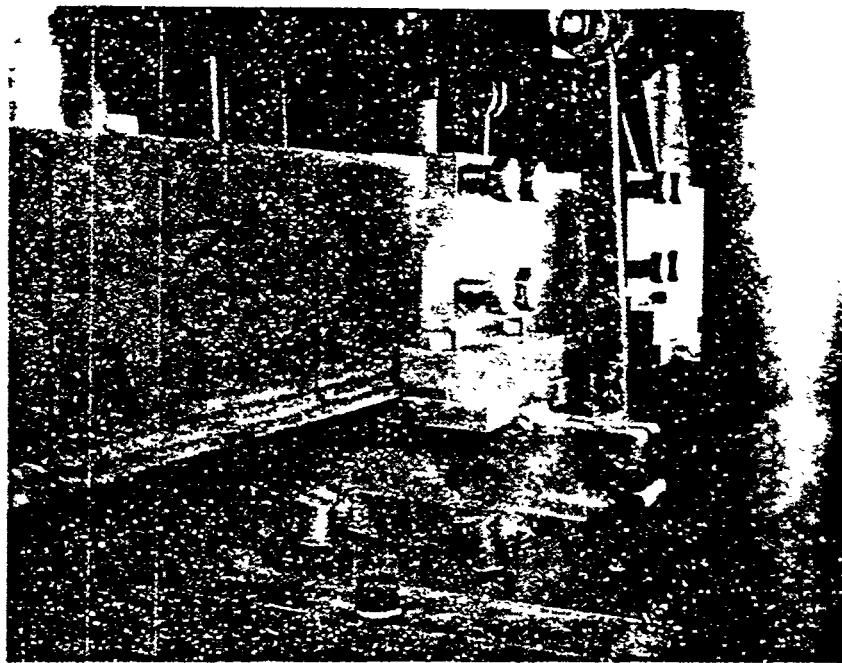

Neg. No. 48006

(b)

Figure 25

Two Views of Double-Action Twist Forming Die Set

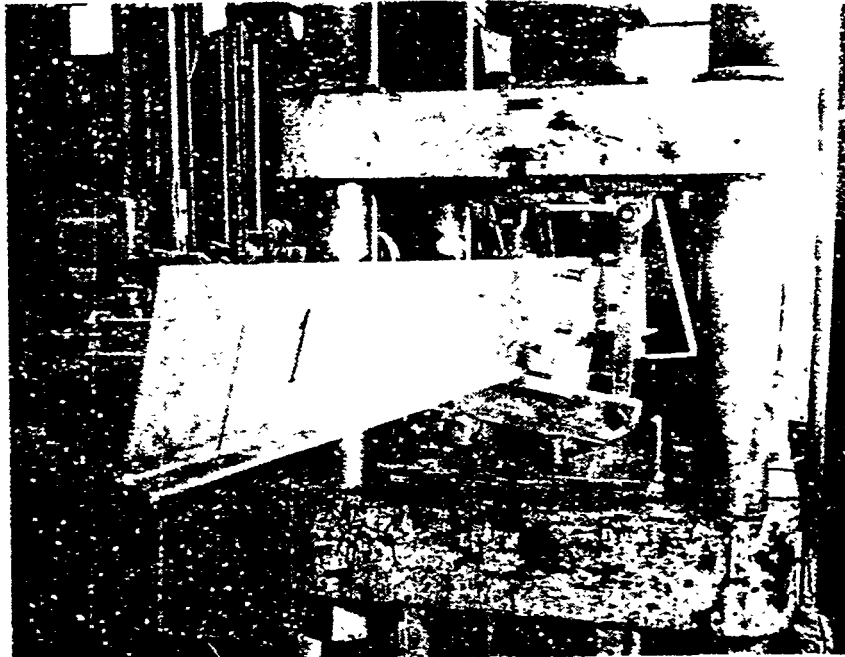

Neg. No. 48009

Figure 26

Double-Action Twist Forming, Caused by Rotation
of Rockers in Opposite Directions
When Press Moves Down

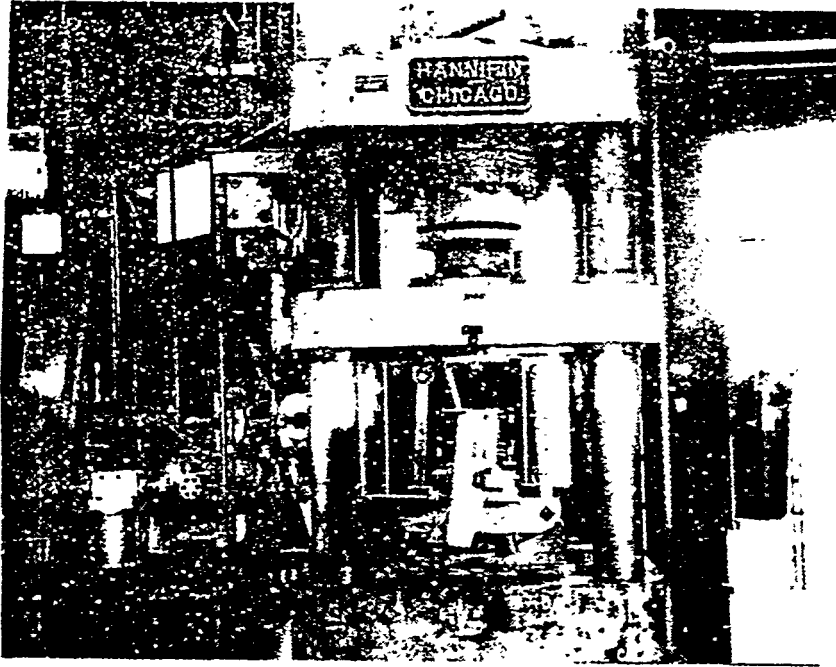

Neg. No. 48007

(a)



Neg. No. 48008

(b)

Figure 27

Front View of Twist Forming Setup in 75-Ton Press,
(a) Before twisting; (b) after twisting.



Neg. No. 48032

(a)

Figure 28

Two Welded T-Sections, Shown After Double Action
Twist Forming. Left: $3^\circ/\text{ft}$ average twist;
right: $6^\circ/\text{ft}$ average twist



Neg. No. 48033

(b)

Figure 28 (cont.)

bending that still persists can only be attributed to positioning errors during die assembly. (One of the coupler bars invariably engaged in the rocker slightly ahead of the other, which may account for any traces of bending still present.)

The double-action twist forming dies were thus successful in producing essentially distortion-free twisting in the subscale T-sections tested.

5. SUMMARY

The feasibility of twist forming T-sections was successfully demonstrated on a subscale basis during the course of this venture. With properly controlled parameters, these sections can be twisted at room temperature in a hydraulic press to result in a significantly higher production rate and considerable savings in cost over the existing (manual) process. The results of this study can now be extended to a full-scale part, for which the forming dies and backup tooling would be designed from the same principles used herein, with added features like accommodating various section sizes and geometries, and using quick-release clamping devices to speed up production.

We have enjoyed working on this venture under the REAPS program, and we trust that the results of the study will help contribute to increased productivity in shipbuilding.