

SHIP PRODUCTION COMMITTEE
FACILITIES AND ENVIRONMENTAL EFFECTS
SURFACE PREPARATION AND COATINGS
DESIGN/PRODUCTION INTEGRATION
HUMAN RESOURCE INNOVATION
MARINE INDUSTRY STANDARDS
WELDING
INDUSTRIAL ENGINEERING
EDUCATION AND TRAINING

September 1979
NSRP 0006

THE NATIONAL SHIPBUILDING RESEARCH PROGRAM

Proceedings of the REAPS Technical Symposium

Paper No. 22: Design for Production

U.S. DEPARTMENT OF THE NAVY
CARDEROCK DIVISION,
NAVAL SURFACE WARFARE CENTER

Report Documentation Page

*Form Approved
OMB No. 0704-0188*

Public reporting burden for the collection of information is estimated to average 1 hour per response, including the time for reviewing instructions, searching existing data sources, gathering and maintaining the data needed, and completing and reviewing the collection of information. Send comments regarding this burden estimate or any other aspect of this collection of information, including suggestions for reducing this burden, to Washington Headquarters Services, Directorate for Information Operations and Reports, 1215 Jefferson Davis Highway, Suite 1204, Arlington VA 22202-4302. Respondents should be aware that notwithstanding any other provision of law, no person shall be subject to a penalty for failing to comply with a collection of information if it does not display a currently valid OMB control number.

1. REPORT DATE SEP 1979	2. REPORT TYPE N/A	3. DATES COVERED -		
4. TITLE AND SUBTITLE The National Shipbuilding Research Program Proceedings of the REAPS Technical Symposium Paper No. 22: Design for Production		5a. CONTRACT NUMBER		
		5b. GRANT NUMBER		
		5c. PROGRAM ELEMENT NUMBER		
6. AUTHOR(S)		5d. PROJECT NUMBER		
		5e. TASK NUMBER		
		5f. WORK UNIT NUMBER		
7. PERFORMING ORGANIZATION NAME(S) AND ADDRESS(ES) Naval Surface Warfare Center CD Code 2230 - Design Integration Tools Building 192 Room 128 9500 MacArthur Blvd Bethesda, MD 20817-5700		8. PERFORMING ORGANIZATION REPORT NUMBER		
		9. SPONSORING/MONITORING AGENCY NAME(S) AND ADDRESS(ES)		
		10. SPONSOR/MONITOR'S ACRONYM(S)		
		11. SPONSOR/MONITOR'S REPORT NUMBER(S)		
12. DISTRIBUTION/AVAILABILITY STATEMENT Approved for public release, distribution unlimited				
13. SUPPLEMENTARY NOTES				
14. ABSTRACT				
15. SUBJECT TERMS				
16. SECURITY CLASSIFICATION OF:			17. LIMITATION OF ABSTRACT SAR	
a. REPORT unclassified	b. ABSTRACT unclassified	c. THIS PAGE unclassified		18. NUMBER OF PAGES 26
				19a. NAME OF RESPONSIBLE PERSON

DISCLAIMER

These reports were prepared as an account of government-sponsored work. Neither the United States, nor the United States Navy, nor any person acting on behalf of the United States Navy (A) makes any warranty or representation, expressed or implied, with respect to the accuracy, completeness or usefulness of the information contained in this report/manual, or that the use of any information, apparatus, method, or process disclosed in this report may not infringe privately owned rights; or (B) assumes any liabilities with respect to the use of or for damages resulting from the use of any information, apparatus, method, or process disclosed in the report. As used in the above, "Persons acting on behalf of the United States Navy" includes any employee, contractor, or subcontractor to the contractor of the United States Navy to the extent that such employee, contractor, or subcontractor to the contractor prepares, handles, or distributes, or provides access to any information pursuant to his employment or contract or subcontract to the contractor with the United States Navy. ANY POSSIBLE IMPLIED WARRANTIES OF MERCHANTABILITY AND/OR FITNESS FOR PURPOSE ARE SPECIFICALLY DISCLAIMED.

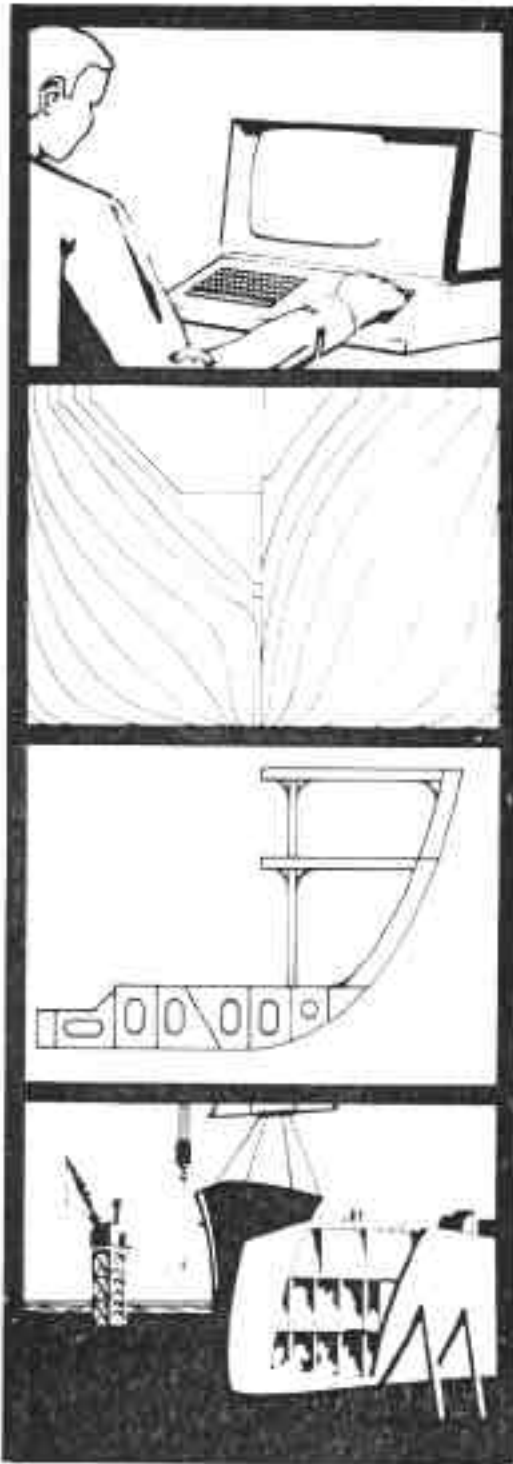

R ESEARCH
E AND
A NGINEERING
S FOR
P AUTOMATION
S AND
PRODUCTIVITY
IN
SHIPBUILDING

Proceedings of the
REAPS Technical Symposium
September 11-13, 1979
San Diego, California

DESIGN FOR PRODUCTION

**Ian MacDougall
Director
A&P Appledore Limited
London, England**

Mr. MacDougall is presently Director of the development engineering and consulting firm A&P Appledore Limited. He has had management training from both Glasgow University and the Administrative Staff College at Henley on Thames; is a chartered engineer and member of the Royal Institute of Naval Architects.

Mr. MacDougall has a number of years experience in ship design, ship construction management, production planning and control, corporate planning, and as controller of costs and methods at the British Shipbuilders Headquarters.

**David Carss
Senior Consultant
A&P Appledore Limited
London, England**

Mr. Carss is a Senior Consultant with A&P Appledore Limited and is a member of the company's team engaged in ship producibility studies, with responsibility for outfit engineering aspects.

A: BACKGROUND TO DESIGN FOR PRODUCTION

I. The Integration of Ship Design and Production

The traditional role of the Ship Designer is the preparation of an overall design of vessel which will have a performance satisfying the owner's Statement of Requirements.

The concept of Design for Production, however, requires that, in satisfying the Statement of Requirement, the Ship Designer should also give attention to ease of production. This suggests, therefore, two aspects of the overall design, namely:

design for performance

design for production

and there are others, not considered here, such as design for repair and maintenance, and ergonomic design.

Clearly, there will be areas of inter-action and the role of the Ship Designer could be seen in this context as one of arbiter, having the ultimate responsibility of deciding whether performance or production considerations should take precedence in any particular case or the nature of the compromise to be reached.

Many of the procedures necessary involve consideration of every feature of the ship from the overall viewpoint. Any tendency to divide design into the traditional elements of steelwork, outfit, engineering and piping would provide a totally inadequate basis upon

which to base effective Design for Production.' Consideration of the inter-relationship between one element and another is essential and the term Integrated Design is used to define this concept.

2. Organisation of the Design for Production Function

The extension of the design process to include a design for production function has the following primary objectives:

To produce a design which represents an acceptable compromise between the demands of performance and production.

To ensure that all design features are compatible with known characteristics of shipyard facilities.

To apply individual Design for Production procedures in so far as they are relevant to the particular shipyard where a vessel is to be built.

To co-ordinate the inter-relationship between the engineering and outfitting work with the structural work, in order to create a fully integrated design.

Examples of the detailed work necessary are as follows:

Hull Geometry and Scantling

The definition of hull shape and structural components should be considered together with the breakdown of the hull into blocks and modules. In addition, consideration should be given to the rationalisation of the scantlings of plates and sections. The relationship between unit/block length and maximum material length is a vital one.

Structural Planning

Concurrently with the above, block and unit breakdowns should be related to shipyard facilities ensuring that the natural breakdown does not conflict with what is practical.

Engineering

The definition of principal machinery and machinery arrangement related to block and unit breakdown. Machinery weights to be allocated to appropriate blocks or units. Principal pipe and cable routes to be defined within machinery spaces.

Pipework

The various piped services within the double bottom to be defined with particular reference to the entry point into the engine room and the effectiveness of a duct keel as a pipe tunnel to be determined. Standard pipe lengths should be examined in relation to block or unit lengths.

3. The Question of Lead Time

Shipyards in Europe, Scandinavia and Japan have traditionally sub-divided the delivery time of ships by creating an extensive period prior to starting production for detailed design, planning and production engineering. This has allowed the greater development of Design for Production techniques and procedures. A short ship production cycle time, characteristic of those countries, itself requires a long lead time to carry out the necessary technical work to allow cycle times to be reduced. The overall delivery period has not necessarily been significantly reduced for individual ships but has been so for series of ships.

4. Improved Producibility

The process of improving productivity can be considered under the following headings:

Designing work content out of the ship design

Improving the efficiency of production processes

Making better use of working hours

Reducing ship production cycle times.

Design for Production is primarily concerned with the first and last categories but Design for Production procedures have benefits, direct or indirect, in the other categories. If productivity is to be increased, the question is not one of whether to implement Design for Production but rather how to implement and to what extent. The traditionally shorter lead times in US shipyards may therefore present a problem until benefits in terms of shorter production cycle times accrue.

Other procedures, particularly equipment and ship module techniques, do require an investment both in time and manpower to realise the potential benefits. In these cases, it is necessary for each individual shipyard to review its own position and define the extent of implementation.

5. Aspects of Production Affected by Design

The effective application of design for production should result in the following:

A rationalised use of materials.

A reduction in work content, including material handling.

A reduction in the cycle time necessary for ship production.

The categories under which a particular procedure is considered to have the greatest effect are listed below. The list should provide some guidance as to the procedures to be adopted in relation to the limits set by a particular production situation.

Rationalised Use of Materials

Rationalised accommodation layout

Grouping and interface simplification

Attention to design details

Attention to pipework details

Reduction in Work Content

Simplified hull form
Continuity of internal surfaces
Effective use of surfaces and spaces
Separation of functional spaces
Standard approach to machinery space layout
Acceptable environmental working conditions
Attention to steelwork design details
Attention to welding design details.

Reduction in Cycle Time

Series production of cargo spaces
Use of equipment modules
Use of ship modules
.Attention to unit and block breakdown
Consideration of ship construction methods.

B: THE METHODOLOGY OF DESIGN FOR PRODUCTION

I. Introduction

The development of improved producibility must parallel the design development work and will influence it at every stage. Aspects of design for production are also capable of further development during the production phase but even at contract design stage, attention should be given both to achieving a generally production kind design and allowing and encouraging further production engineering work in a post contract context.

2. Simplification of Hull Form

To the greatest extent possible within the dictates of the performance specification, the lines of a ship should be formed from a combination of simple shapes so that the work content inherent in production of the structure forming the hull surface may be reduced. The basic concept is a performed order of increasing complexity:

straight lines or flat surfaces
surfaces having curvature in one plane only
surfaces having curvature in two planes.

Although the lines of the ship are often quite tightly defined, small changes not significantly affecting performance may be possible to allow improved producibility (Ref. fig. 1).

3. Continuity of Internal Surfaces

Where possible and desirable, the internal volume of the hull should be divided so as to provide continuity of surfaces in the horizontal, longitudinal and transverse planes. Surfaces which may be either part of the main structure or a local element should be within the principal planes and not angled to them. Steps, cranks, recesses and other forms of discontinuity should be avoided so far as possible unless required to simplify end connections or because of specific authority (Ref. fig '2).

The internal spatial configuration will generally be easier to influence than the hull form and it is important to fully investigate this aspect to allow further work to be done in the area of block breakdown and advanced outfitting.

4. Effective Use of Surfaces and spaces

Platforms and bulkheads should be so positioned that each performs the maximum number of functions which may be assigned to it. By objective consideration of these functions, simplification of layout, particularly in accommodation spaces, may be achieved leading to savings in material and simplified access for welding and painting.

5. Separation of Functional Spaces

Examination of the machinery space of many types of merchant ship reveals a number of functional divisions under which any design may be considered. The concept may be fully exploited by the development

of a standardised design approach to the machinery space allowing easier development of the design for alternative propulsion systems. In those shipyards possessing the necessary facilities, the concept should be extended to allow the production of each functional division to be carried out in the form of one or more ship modules.

Examples of the possible functional separation are:-

Propulsion

Auxiliary services

Ancillary services

Exhaust removal

Accommodation and ship control.

(Ref. fig 3)

6. Grouping and Interface Simplification

Well defined routes for systems should be established at an early stage of the design, both to simplify installation procedures and to establish the physical aspects of interfacing requirements. Systematic grouping should be adopted to the maximum possible extent.

Typical applications are:

Fuel oil, bilge and ballast lines running fore and aft within the double bottom possibly inside a duct keel.

Fuel oil, salt water, fresh water, air, steam, hydraulics and electrics running at various levels in the machinery space.

Vertical connecting runs within the machinery space and from the machinery space to the accommodation block.

The establishment, for example, of pipe passages provides the possibility of maximum use of standard, straight lengths of pipe. These can be arranged in the form of large pipework assemblies, with the pipe supports designed to permit both workshop manufacture of the assembly and, due to inherent rigidity, transportation to the ship without damage to the joint seals (Ref. fig 4).

7. Rationalised Accommodation Layout

The shape of accommodation blocks should be simple with maximum use of straight lines and flat surfaces for boundaries and internal division. Rooms and contents should be standardised as far as possible (Ref. fig 5).

8. Series Production of Cargo Spaces

Wherever possible, the overall arrangement of the design should facilitate the division of the cargo length into equal length units/blocks which are the most appropriate for the facilities of any given shipyard.

9. Use of Equipment Modules

Some shipyards will have sufficient facilities to allow groups of auxiliaries to be formed into equipment modules by mounting them on a common base plate. Equipment Modules should be assembled in a workshop remote from the building berth. Although not all shipyards will have the

appropriate facilities, the development of the design should encourage the subsequent application of this concept,

I0. Use of Ship Modules

Blocks equipped with a number of outfit assemblies or equipment modules, referred to as Ship Modules, are applicable to any part of the ship where multiple trades are required to manufacture and equip. Ship modules should be assembled in a work shop remote from the building berth. The application of ship modules is assisted by the functional layout of the machinery spaces. Again, fewer shipyards will have the necessary facilities but the ship design should allow for their subsequent development (Ref. fig 6).

II. Consideration of Design Details

Design detailing procedures as influenced by design for production techniques conveniently divide themselves into the following major areas:-

- Steelwork design**
- Unit and block breakdown**
- Pipework design**
- Electrical and other outfit systems**
- Ship construction**
- Welding design.**

At this level, recommended design details can not be of universal application. The extent to which procedures can be adopted in a particular shipyard is dependent on the level of technology appropriate to the

shipyard, A number of general themes do, however, manifest themselves and will be applied. For example, the following list is illustrative but not exhaustive:

Steelwork design at all levels of detail should be directed towards effective use of facilities and manpower as they exist in the industry. The ship designer should always aim to remove the inherent work content in a design (Ref. fig 7).

Unit and block divisions should be based on the natural divisions within the hull structure and should be of a standard length over as long a length of the ship as possible, as close as possible to the maximum material length or a multiple of it that may be readily handled within shipyard facilities (Ref. fig 8).

Simple geometric shapes to reduce the variety of complicated shapes should be used to improve the efficiency of pipework manufacture and installation.

Units and blocks should be defined so as to be self supporting, capable of progressive erection and easily faired and welded, with the provision of access and working platforms wherever possible by the structural features of the hull (Ref. fig 9).

For a given weldment in specified scantlings, the length of welding can be minimised by design considerations. Joints should be designed to reduce the work prior to welding.

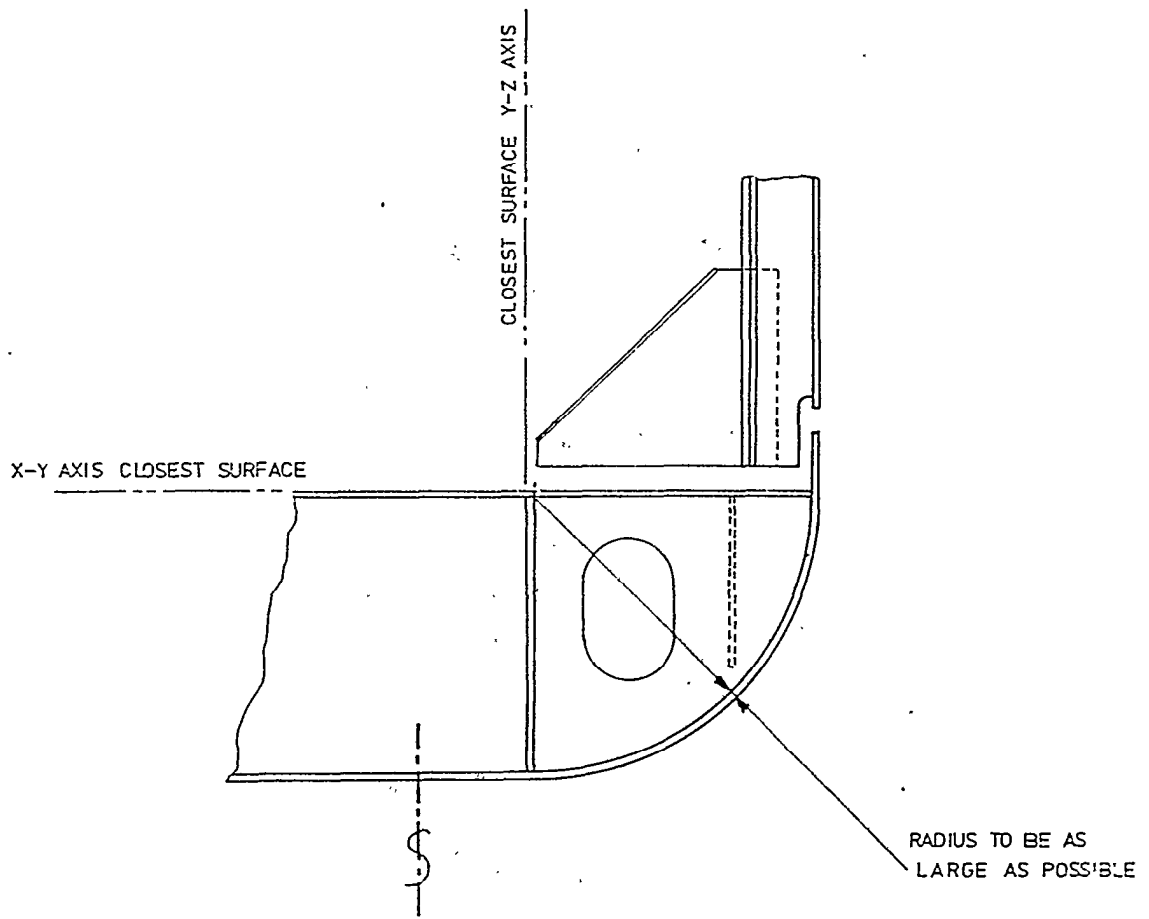

ARRANGEMENT OF BILGE PLATING

Fig. 1

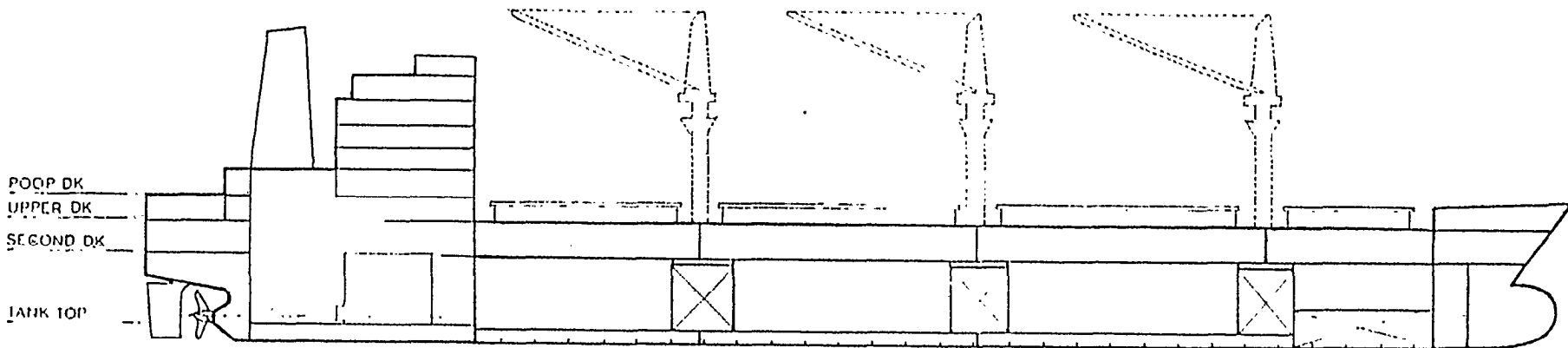

477

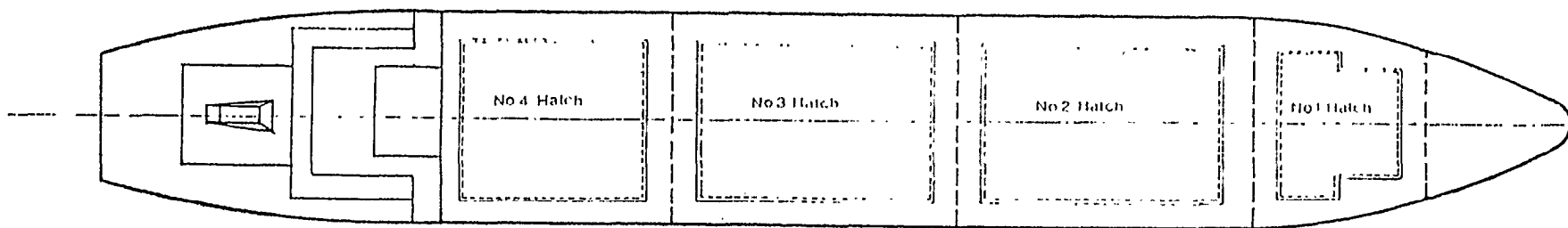
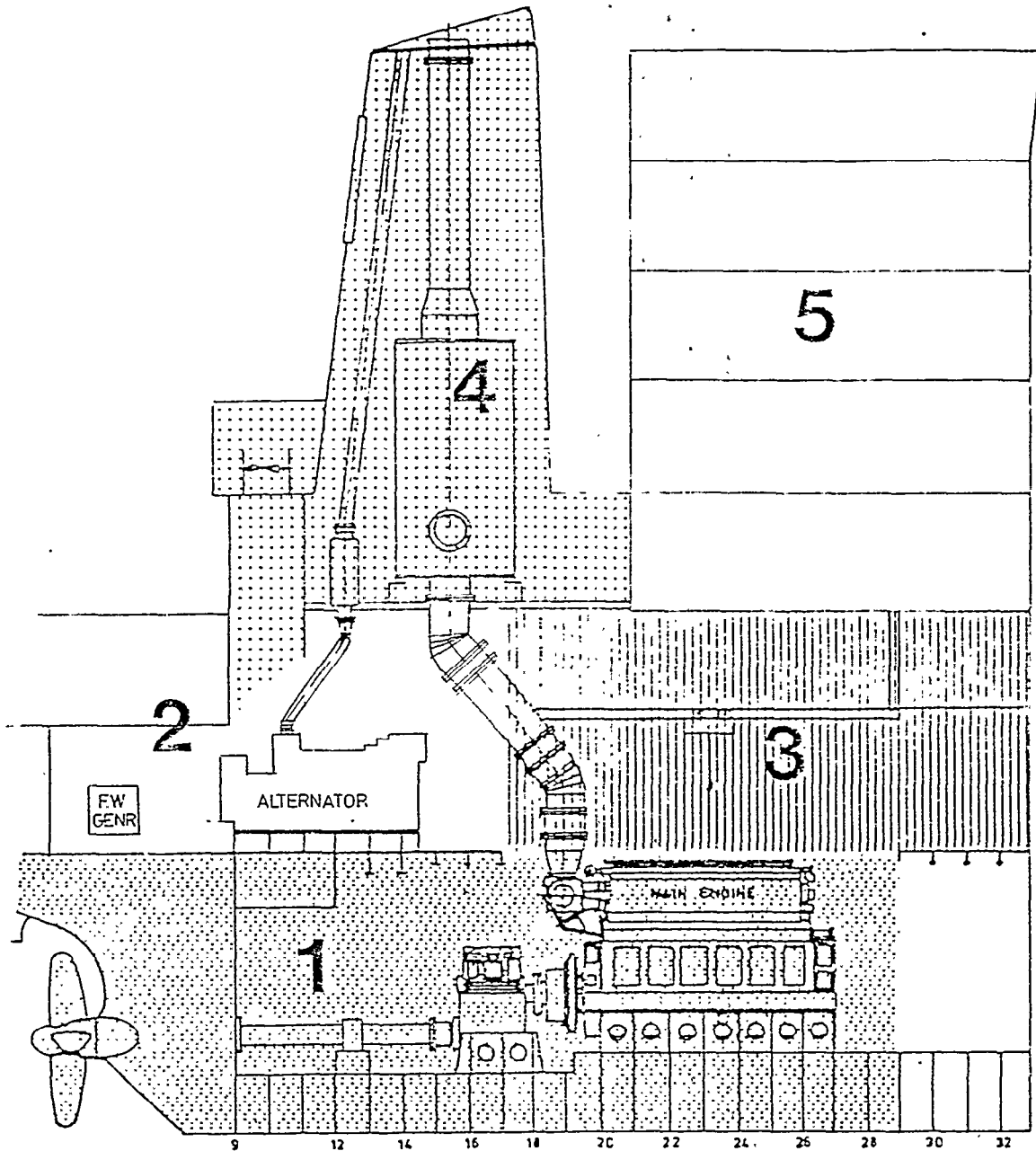

Fig 2

TYPICAL 17, 800 DWT MULTI PURPOSE CARGO SHIP

- Showing - Continuity of internal surfaces**
 - Separation of **functional** spaces
 - **Effective use of surfaces and spaces**



- KEY.
- 1. MAIN PROPULSION
 - 2. AUXILIARY
 - 3. ANCILLARY
 - 4. EXHAUST
 - 5. ACCOMMODATION AND SHIP CONTROL

**CENTRE LINE ELEVATION
OF MACHINERY SPACE OF A 3,600 BHP VESSEL**

Showing - Separation of functional spaces

Fig. 3

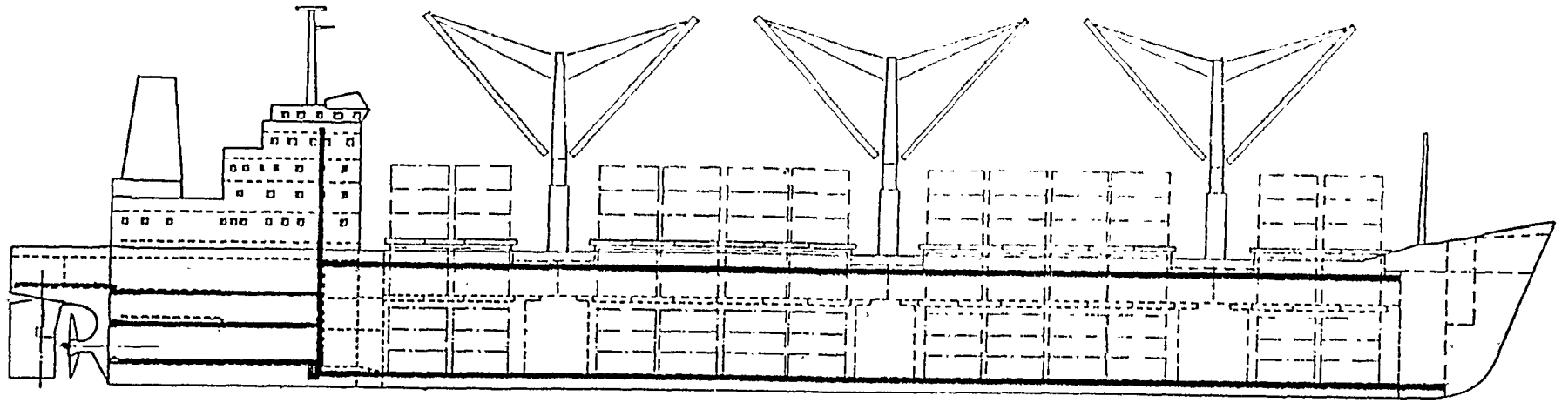

479

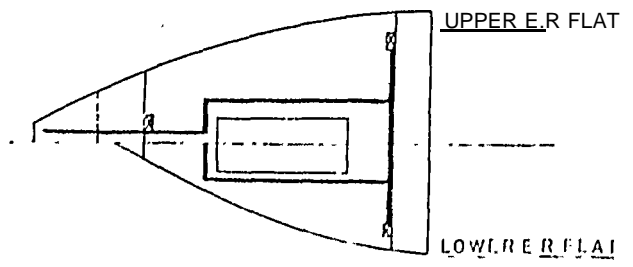
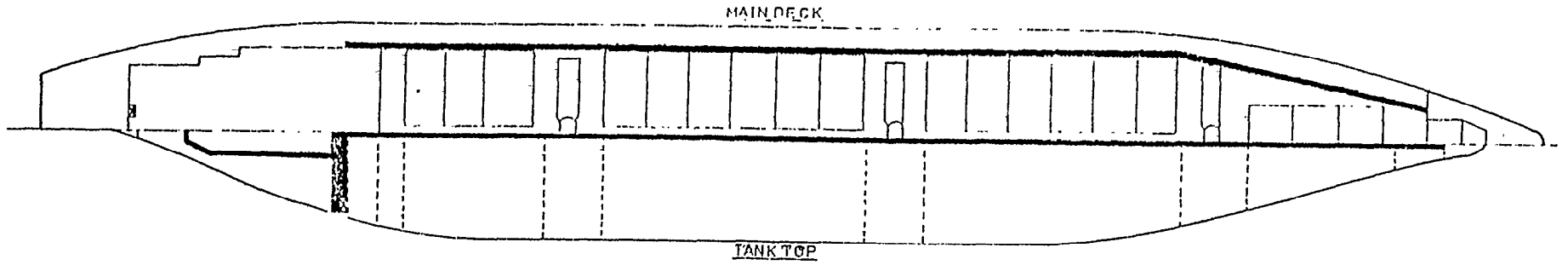

SYSTEMS GROUPING AND ALLOCATION OF ROUTING SPACES

Fig. 4

ACCOMMODATION LAYOUT OF 4000 DWT CONTAINER SHIP

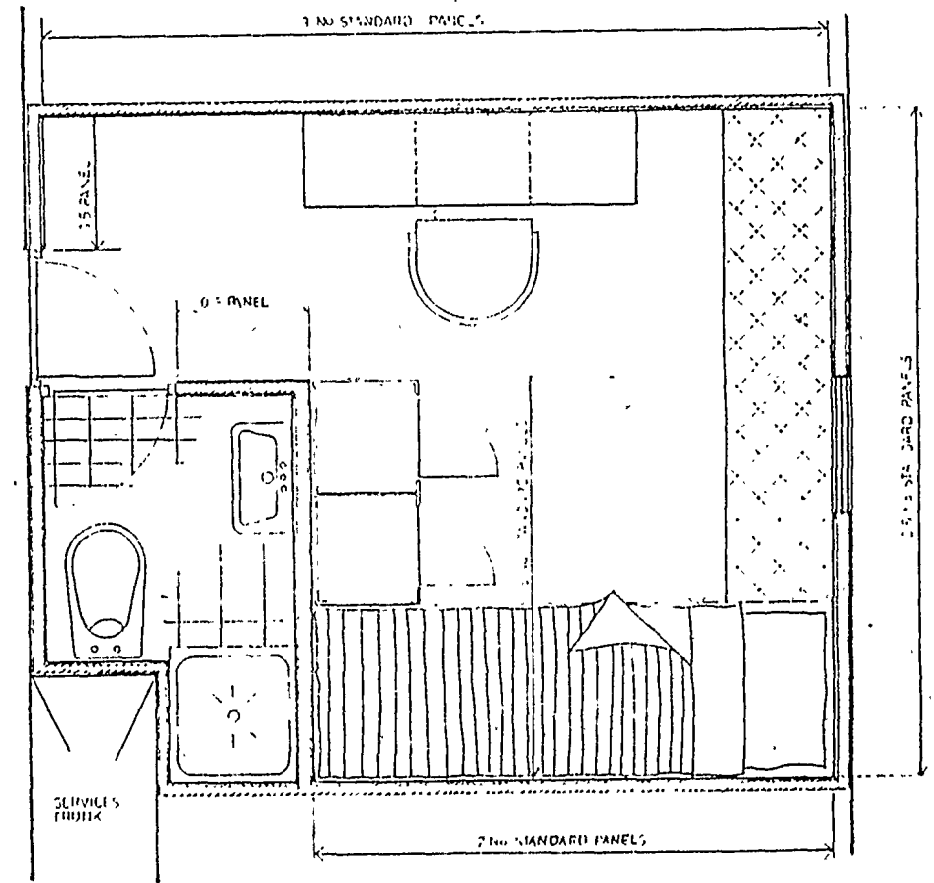
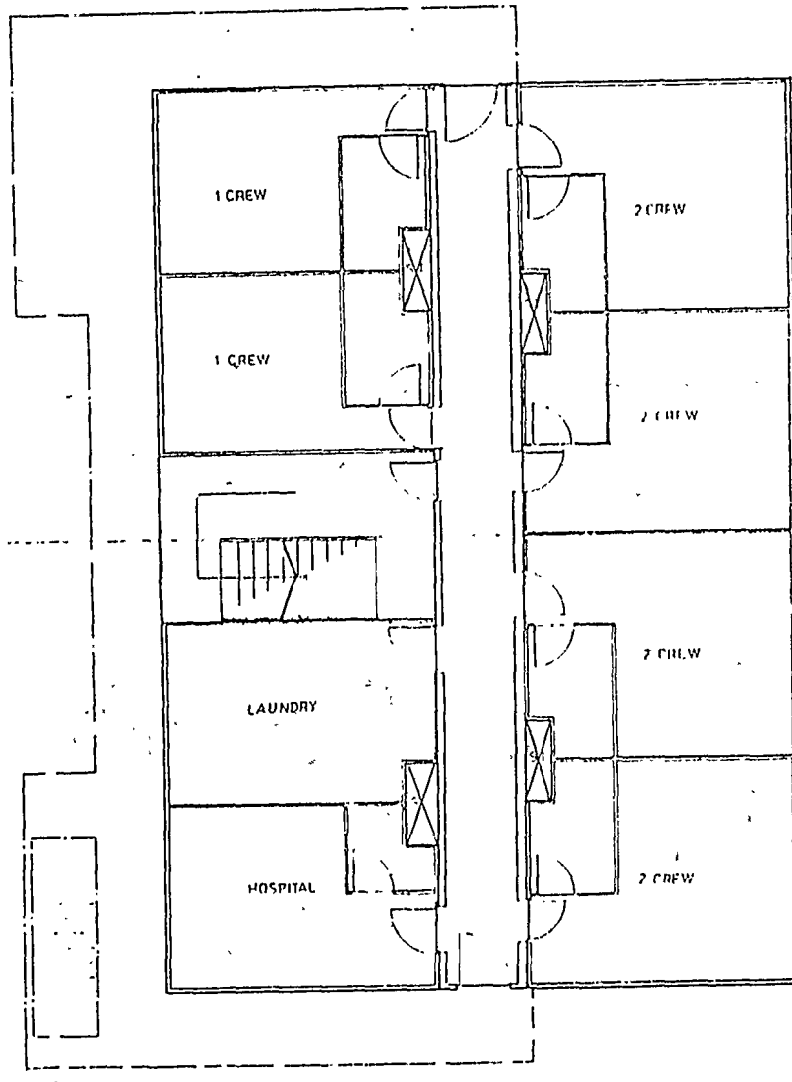

- Cabin dimensions sized to suit panel standard size
- Standard furniture
- Centralised service trunks

481

Fig. 6

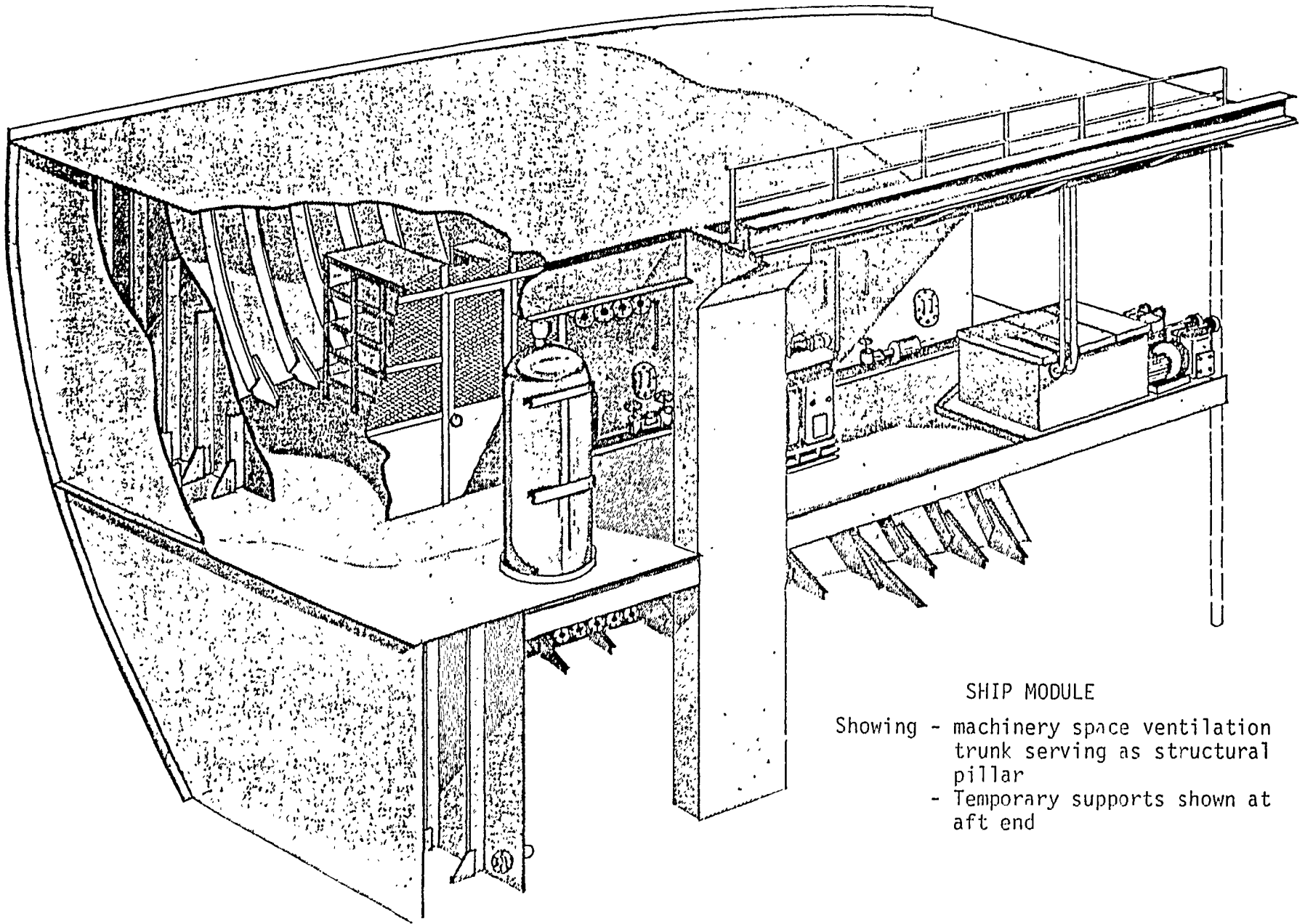

SHIP MODULE

- machinery space ventilation trunk serving as structural pillar
- Temporary supports shown at aft end

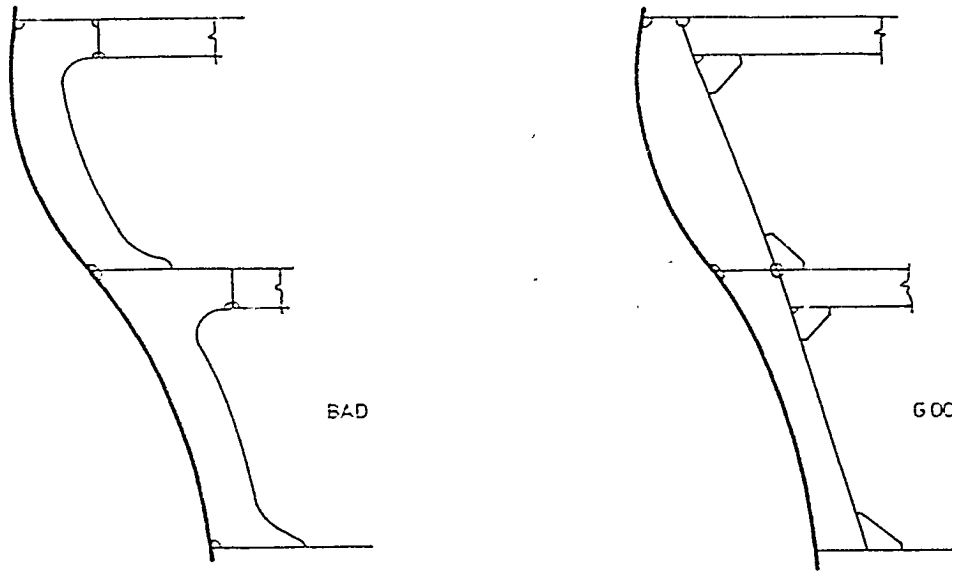

ELIMINATION OF ROLLED FACE FLATS

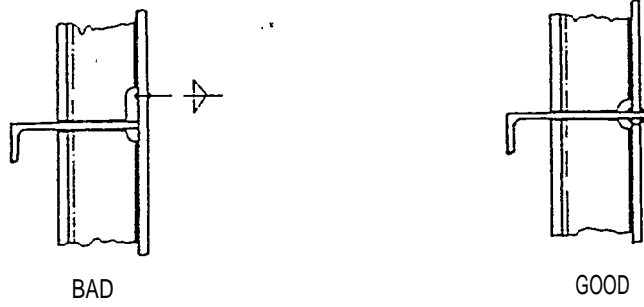

POSITION OF SHELL PLATE JOINTS

Fig. 7

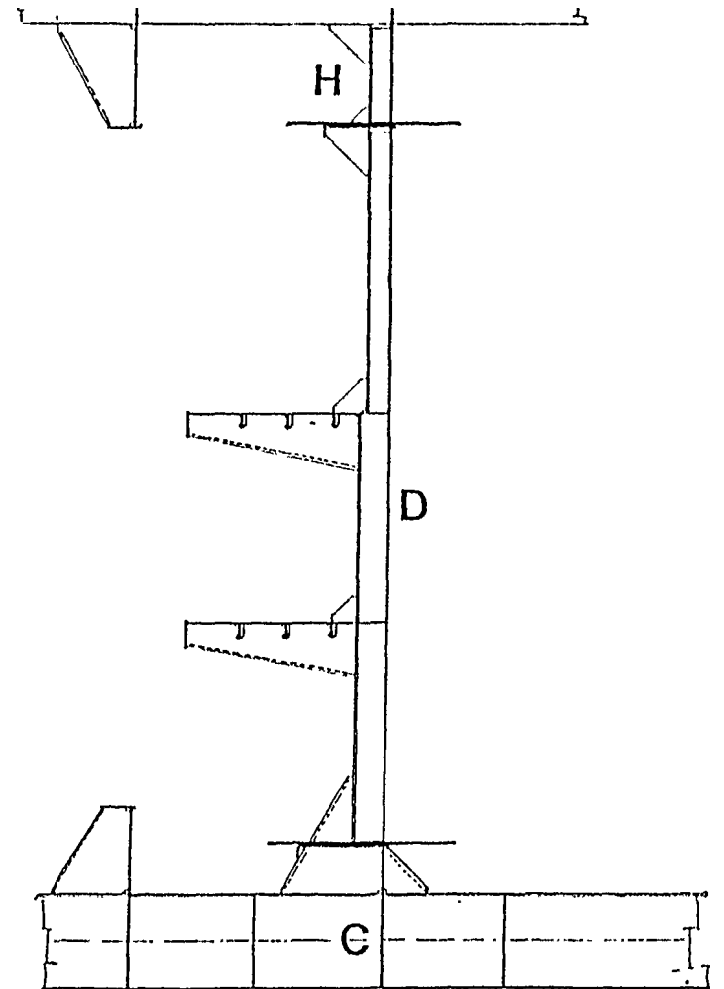
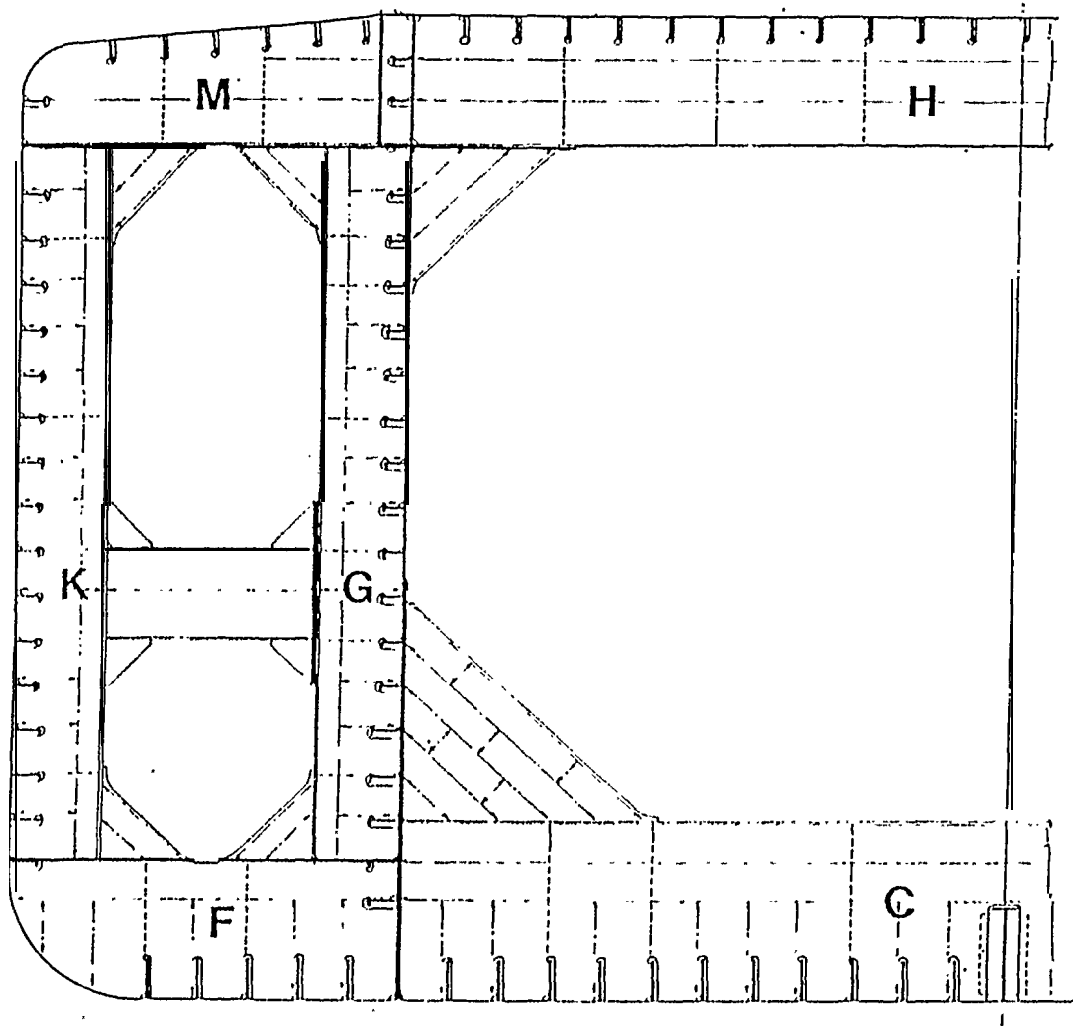
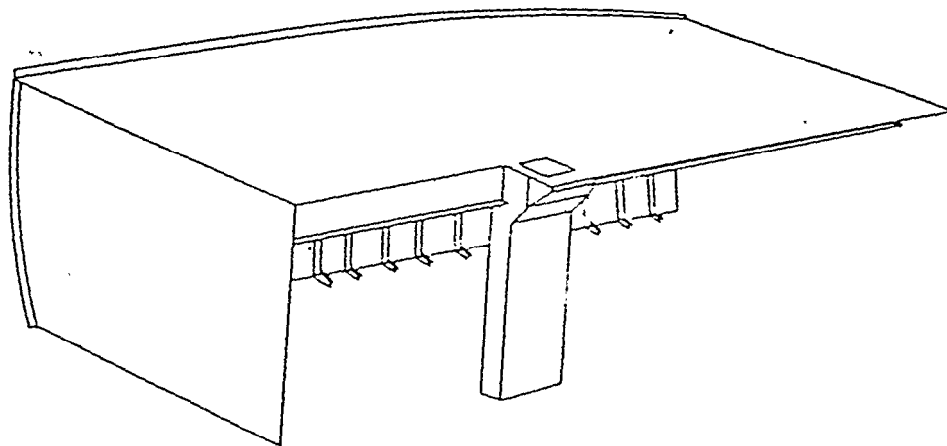
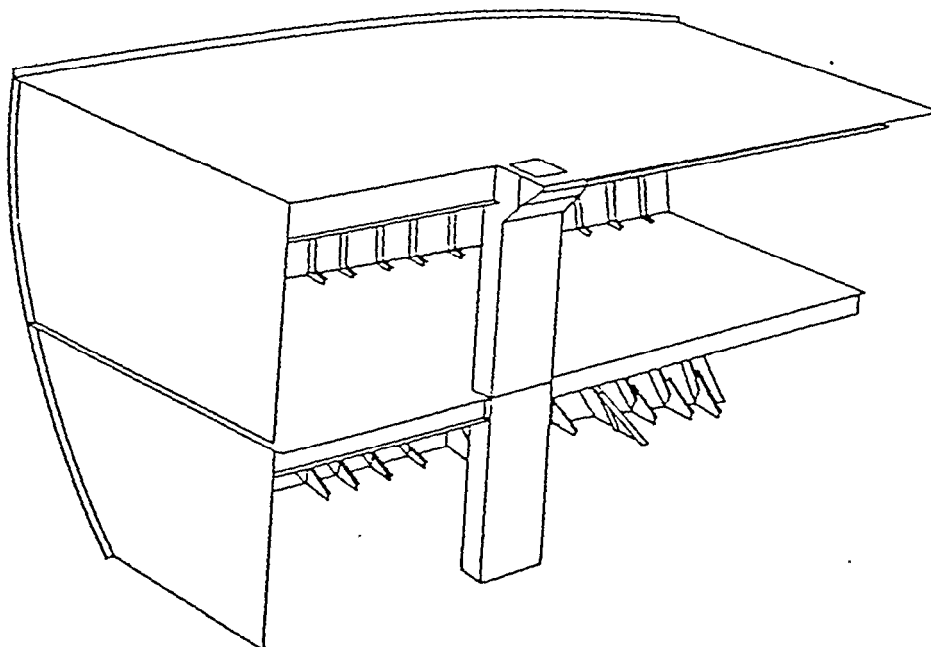

FIG. 3

BLOCK BREAKDOWN OF 60,000 DWT TANKER



STEELWORK UNIT



STEELWORK BLOCK

Fig. 9

Additional copies of this report can be obtained from the
National Shipbuilding Research and Documentation Center:

<http://www.nsnet.com/docctr/>

Documentation Center
The University of Michigan
Transportation Research Institute
Marine Systems Division
2901 Baxter Road
Ann Arbor, MI 48109-2150

Phone: 734-763-2465

Fax: 734-763-4862

E-mail: Doc.Center@umich.edu