

NSRP-0153

UNTRI

71769

LONG RANGE FACILITIES
PLANNING
INDUSTRIAL SURVEY
VOL, III OF V

Transportation
Research Institute



NATIONAL STEEL AND SHIPBUILDING COMPANY
A MORRISON-KNUDSEN COMPANY

Report Documentation Page

Form Approved
OMB No. 0704-0188

Public reporting burden for the collection of information is estimated to average 1 hour per response, including the time for reviewing instructions, searching existing data sources, gathering and maintaining the data needed, and completing and reviewing the collection of information. Send comments regarding this burden estimate or any other aspect of this collection of information, including suggestions for reducing this burden, to Washington Headquarters Services, Directorate for Information Operations and Reports, 1215 Jefferson Davis Highway, Suite 1204, Arlington VA 22202-4302. Respondents should be aware that notwithstanding any other provision of law, no person shall be subject to a penalty for failing to comply with a collection of information if it does not display a currently valid OMB control number.

1. REPORT DATE APR 1982		2. REPORT TYPE N/A		3. DATES COVERED -	
4. TITLE AND SUBTITLE Long Range Facilities Planning Industrial Survey Vol, III of V				5a. CONTRACT NUMBER	
				5b. GRANT NUMBER	
				5c. PROGRAM ELEMENT NUMBER	
6. AUTHOR(S)				5d. PROJECT NUMBER	
				5e. TASK NUMBER	
				5f. WORK UNIT NUMBER	
7. PERFORMING ORGANIZATION NAME(S) AND ADDRESS(ES) Naval Surface Warfare Center CD Code 2230 - Design Integration Tools Building 192 Room 128 9500 MacArthur Bldg Bethesda, MD 20817-5700				8. PERFORMING ORGANIZATION REPORT NUMBER	
9. SPONSORING/MONITORING AGENCY NAME(S) AND ADDRESS(ES)				10. SPONSOR/MONITOR'S ACRONYM(S)	
				11. SPONSOR/MONITOR'S REPORT NUMBER(S)	
12. DISTRIBUTION/AVAILABILITY STATEMENT Approved for public release, distribution unlimited					
13. SUPPLEMENTARY NOTES					
14. ABSTRACT					
15. SUBJECT TERMS					
16. SECURITY CLASSIFICATION OF:			17. LIMITATION OF ABSTRACT SAR	18. NUMBER OF PAGES 64	19a. NAME OF RESPONSIBLE PERSON
a. REPORT unclassified	b. ABSTRACT unclassified	c. THIS PAGE unclassified			

NATIONAL SHIPBUILDING RESEARCH PROGRAM

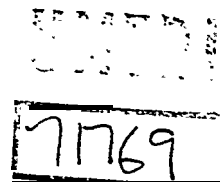

SP-1 FACILITIES PANEL PROJECT



LONG RANGE FACILITIES

PLANNING

INDUSTRIAL SURVEY

VOL. III OF V

NATIONAL STEEL AND SHIPBUILDING COMPANY

IN COOPERATION WITH THE

DEPARTMENT OF TRANSPORTATION

MARITIME ADMINISTRATION

APRIL, 1982

INDUSTRY SURVEY

Volume III

TABLE OF CONTENTS

- U. S. Shipyard Technology Matrix
- Industry Survey

NATIONAL STEEL AND SHIPBUILDING COMPANY

INTER-DEPARTMENT MEMO

Date: 6/4/80

To: C. L. French via R. H. Vortmann, A. Giorgis, J. Lightbody
& L. P. Haumschilt
Subject: LRF Industry Survey Job No. _____
From: T. S. Roach & J. R. Ruecker Dept. _____

The major portion of the shipbuilding industry survey was conducted from May 12 to June 3, 1980. The survey included the following eleven U. S. shipyards:

Todd Pacific Shipyard Corp.	San Pedro, Calif.
Livingston Shipbuilding Co.	Orange, Texas
Ingalls Shipbuilding/Litton. Industries	Pascagoula, Miss.
Avondale Shpyards, Inc.	New Orleans, La.
Newport News Shipbuilding & Drydock Co..	Newport News, Va.
Norfolk Shipbuilding & Drydock Corp.	Norfolk, Va.
Sun Shipbuilding & Drydock Co.	Chester, Pa.
G. D. Corp. - Quincy Shipbuilding Div.	Quincy, Mass.
Bath Iron Works Corp.	Bath, Me.
Peterson Builders	Sturgeon Bay, Wis.
Bay Shipbuilding Corp.	Sturgeon Bay, Wis.

All yards with the exception of Quincy welcomed us graciously and were cooperative in sharing their facilities and experiences with us. Quincy on the other hand was reluctant to permit our visit and hurried us through their facilities. After viewing their facilities we concluded that their reluctance to let us in was due to their possible embarrassment over the low level of operations. Their employment is at an all time low, probably less than 2000, with no new work in sight.

Key points of the survey are expanded upon in the following pages. Also attached are the comments on each yard visited.

Respectfully,



T. S. Roach, Supervisor
Facilities Engineering



J. R. Ruecker
Senior Industrial Engineer

m/cm

U. S. SHIPYARD TECHNOLOGY MATR

SHIPYARD \ ITEM	PRECONSTRUCTION PRIMER	PANEL LINE			SMALL PARTS STATION	NOTES
		PANEL STATION	STIFFNER STATION	WEB STATION		
NASSCO	No	Yes	No	No	No	
Todd-Pacific Shipyard Co.	Yes	Yes	No	No	No	
Levingston Shipbuilding Co.	Yes	Yes ⁽¹⁾	Yes ⁽¹⁾	No ⁽²⁾	No ⁽²⁾	(1) New not in use yet (2) Room allowed for addition to panel line.
Ingalls Shipbuilding Litton Industries	No	Yes	Yes	Yes	Yes	1) Panel unit max of 80 T.
Avondale Shipyard Inc.	Yes ⁽¹⁾	Yes	Yes	Yes	Yes	(1) Primer removed from weld areas.
Newport News Shipbuilding & Drydock Co.	Yes ⁽¹⁾	Yes	Yes	Yes	Yes	(1) Primer removed from weld areas.
Norfolk Shipbuilding & Drydock Corp.	No	No	No	No	No	
Sun Shipbuilding & Drydock Co.	Yes ⁽¹⁾	Yes ⁽²⁾	Yes ⁽²⁾	Yes ⁽²⁾	Yes ⁽²⁾	(1) Primer removed from weld area primer blasted off. (2) New in 1980.
G. D. Corp.-Quincy Shipbuilding Div.	No	Yes	Yes	Yes	Yes	
Bath Iron Works Corp.	Yes	No	No	No	No	
Peterson Builders	Yes ⁽¹⁾	No	No	No	No	(1) Prime 50% of the time.
Bay Shipbuilding Corp.	Yes	Yes	Yes	Yes	Yes	

U. S. SHIPYARD TECHNOLOGY MATRIX

ITEM SHIPYARD	NUMBER BUILDING POSITIONS	NUMBER DRYDOCKS	BERTHS LIN. FT.	MAX. CRANE LIFT (TONS)	MOVEMENT OF UNITS	NOTES
NASSCO	4 (1)	1 (2)	6,355	175	Cranes	(1) Three inclined ways one building basin. (2) Leased at NASSCO with other companies.
Todd-Pacific Shipyard Co.	2 (1)	2	4,800	175 (2)	Flat Bed Transporters	(1) Inclined ways. (2) Two 175 T Cranes.
Levingston Shipbuilding Co.	1 (1)	3	2,400	$\frac{400}{120}$	Flat Bed Transporters Cranes	(1) Side launch way 1200' long. (2) 400 ton barge crane, 120 ton in yard crane.
Ingalls Shipbuilding Litton Industries	1 (1)	0 (2)	4,000	200	Self propelled Transporter 200 Ton	(1) Launch pontoon fed by five construction bays. (2) No drydock activity in new construction facility.
Avondale Shipyard Inc.	2 (1)	3 (2)	3,600	$\frac{600}{200}$ (3)	Self propelled transporter 500 Ton	(1) Side launch ways both approx. 1200' long. (2) Flat slab utilizing drydock for launching. (3) 600 Ton barge crane.
Newport News Shipbldg & Drydock Co.	10 (1)	5 (2)	12,000	$\frac{900}{275}$ (3)	Self propelled transporter 550 Ton Railcars 50 T.	(1) 5-inclined ways, 2-basins, 3-graving docks. (2) Use basins as graving docks. (3) 900 Ton Goliath, 275 Whir.
Norfolk Shipbuilding & Drydock Corp.	5 (1)	2 (2)	12,000	65	Flat bed transporter	(1) 4 marine railways and 1-inclined way. (2) New drydock 950' x 192'.

U.S SHIPBUILDING TECHNOLOGY MATRIX
(continued)

SHIPYARD \ ITEM	NUMBER BUILDING POSITIONS	NUMBER DRYDOCKS	BERTHS LIN . FT.	MAX. CRANE LIFT (TONS)	MOVEMENT OF UNITS	NOTES
Sun Shipbuilding & Drydock Co.	4 (1)	1	3,900	$\frac{800}{250}$ (2)	self propelled transporter 225 Ton Railcars 50 T.	(1) 2-inclined ways, 2-hydraulic Flat Slabs utilizing drydock for launchings. (2) 800 Ton barge crane, 250 Ton in yard crane.
G.D.Corp.-Quincy Shipbuilding Div.	5 (1)	4 (2)	4,600	$\frac{1200}{175}$ (3)	Self propelled transporter 240 Railcars 50 T.	(1) 3-building basins, 2 new construction basins. (2) Basins are also used for drydocking. (3) 1200 Ton Goliath, 175 Whirley.
Bath Iron Works Corporation	4 (1)	1	2,900	220	self propelled transporter	(1) Inclinedways
Peterson Builders	1 (1)	1	N/A	200	Transporter Crawler crane	(1) Side launch
Bay Shipbuilding Corporation	2 (1)	1	7,090	200	Crawler Transporter and chine.	(1) 1-side launch, and 1 graving dock.

U. S. SHIPYARD TECHNOLOGY MATRIX

ITEM SHIPYARD	NUMBER OF EMPLOYEES	SITE SIZE (ACRES)	TYPE WORK		OTHER WORK	NOTES
			NEW CONSTRUCTION	REPAIR		
NAS CO	6,800	147	AD Tankers 35, to 190,000 DWT	Yes	-	
Todd-Pacific Shipyard Co.	3,600	90	FFG-7 (1)	Yes (1)		(1) Past has been all repair work, increased activity in new construct
Livingston Shipbuilding Co.	2,000	100	Bulkers 32,000 DWT	Yes (1)	Jack-Ups Drill Rigs Semi-Submersible	(1) First priority in yard is repair work. Separate repair facilities down river and N/C facilities is used to support repair work.
Ingalls Shipbldg. Litton Industries	1,000	611 (1)	Spruance Class Destroyers	(2)	Jack-Ups Drill Platforms Semi- Submersible	(1) Only using 400 acres. (2) Separate repair facility across river.
Avondale Shipyard Inc.	6,500	218	Tankers 42,000 DWT	Yes	Barges Drill Platforms Tugs	
Newport News Shipbldg. & Drydock	22,000	475	ING Crubs (1) Carriers, Air- craft Carriers, Submarines	Yes		(1) North yard dedicated to com- mercial work and south yard to Navy work.
Norfolk Shipbldg. & Drydock Corp.	2,500	120	No	Yes	-	
Sun Shipbuilding & Drydock Co.	4,000	200	Ro-Ro Med. Tankers	Yes	Pressure Vessels Oil Refinery Equip. Wind Tunnels	
G. D. Corp.-Quincy Shipbuilding Div.	1,500 (1)	180	ING	Yes		(1) Estimated

U. S. SHIPYARD TECHNOLOGY MATRI
(continued)

SHIPYARD \ ITEM	NUMBER OF EMPLOYEES	SITE SIZE (ACRES)	TYPE WORK		OTHER WORK	NOTES
			NEW CONSTRUCTION	REPAIR		
Bath Iron Works Corp.	6,000	55 ⁽¹⁾	FFG-7	Yes	Steel Fab. for Nuclear plant.	(1) Includes 25 acre off-site steel fabrication plant.
Peterson Builders	950	13	Tuna Boats ⁽¹⁾ Patrol Ships	Yes	Tractor Transporters	(1) Capable of building steel, aluminum, wood and fiberglass vessels
Bay Shipbuilding Corp.	1,500	36	Ore-Carriers	Yes		

U. S. SHIPYARD TECHNOLOGY MATRIX

SHIPYARD \ ITEM	JIGS & FIXTURES	BLAST FACILITY	PAINT FACILITY	USE OF MANLIFTS	NOTES
NASSCO	Jig Pins	Outside	Outside	Yes ^{1,2}	(1) only several currently in use.
Todd-Pacific Shipyard Co.	Fixed Jigs	Outside ⁽¹⁾	Outside	No	(1) Have enclosed facility for small assemble
Levingston Shipbuilding Co	Jig Pins	Outside	Outside	No	
Ingalls Shipbuilding Litton Industries	Jig Pins	Inside ⁽¹⁾	Inside ⁽²⁾	Yes	(1) Auto blast facility, max. unit 80 tons. (2) Unit moved to another building for paintin
Avondale Shipyard Inc.	Fixed Jigs	Inside ⁽¹⁾	Inside ⁽¹⁾	Yes	(1) Blasting and painting occurs in the same building with a separate room for each function (blast, clean, paint and dry).
Newport News Shipbuilding & Drydock	Jig Pins	Outside ⁽¹⁾	Outside	Yes	(1) NPN has a small inside blast facility which handles only 10% of the work. All large unit blasting is done outside.
Norfolk Shipbuilding & Drydock Corp.	Fixed Jigs	Outside	Outside	Yes	
Sun Shipbuilding & Drydock Corp.	Jig Pins	Inside ⁽¹⁾	Inside ⁽¹⁾	Yes	(1) New blast and paint facility, May 1980. Blasting and painting done in the same room.
G. D. Corp.-Quincy Shipbuilding Div.	Fixed Jigs	Inside ⁽¹⁾	Inside ⁽²⁾	Yes	(1) Auto blast facility max unit 80 tons. (2) Unit moved to another building for paintin
			(6)		

U , S . SHIPYARD TECHNOLOGY MATRIX
(Continued)

SHIPYARD / ITEM	JIGS & FIXTURES	BLAST FACILITY	PAINT FACILITY	USE OF MANLIFTS	NOTES
Bath Iron Works Corp.	Fixed Jigs ⁽²⁾	Inside ⁽¹⁾	Inside ⁽¹⁾	Yes	(1) Blast & paint same building different rooms. (2) Planning to use Jig Pins in the near future.
Peterson Builders	Fixed Jigs	Inside ⁽¹⁾	inside ⁽¹⁾	Yes	(1) New blast & paint facility May 1900. Blasting & painting done in different buildings due to lack of space. If space was available it would of been one building with a room for each function.
Bay Shipbuilding Corp.	Fixed Jigs	Inside ⁽¹⁾	Inside ⁽¹⁾	No	(1) Semi-encloeed roof & 1/2 wall. Blast and paint occurred in same building.

I. KEY POINTS OF INTEREST

A.) Preconstruction Primer:

Preconstruction primer was observed being used at a number of yards visited. Each yard has approached the use of primer in a variety of techniques. The application of primer to steel was observed being done both manually and automatically. In the manual method they claimed to hold to 3/4 of a mil., while in the use of automatic equipment it is hard to hold to 3/4. We would tend to believe that the automatic equipment is more consistent and would hold to a closer tolerance. The most popular brand of preconstruction primer used was International. There have been several approaches taken to welding on units with preconstruction primer. One way is to strip all primer off of the surface areas to be welded. The other method is to weld over the primer. There is presently a project in the F. & I.E. Department to study preconstruction primer applicability to NASSCO.

B.) Blast & Paint Facilities:

Blasting and painting was observed being done in different environments. Outside, inside manually and inside automatically. Still the most popular way to blast and paint is outside in the open, if it can be done. The enclosed units are very expensive to install. Example, Sun has just built a two cell manual blast and paint facility for 10 million dollars. The blasting rooms tend to self-destruct and have a very high maintenance cost. Ingalls' blast facility was down for a six week repair. After seeing the expense of installing and maintaining such facilities, it is felt NASSCO should continue to blast and paint outside until forced to move inside.

C.) Panel Line Operations:

Sixty-four percent of the yards visited had, or are currently installing, panel lines with a stiffener positioning and welding station. The brands of panel lines in use were, Esab-Hebe, Ogden and TTS (Total Transportation System). There were two basic methods of positioning and welding stiffeners to the units. The most traditional method was to position and weld stiffeners to panels. The panels first had to be manually laid out, then the stiffener positioned and tacked to the panel. The panel then was moved to the weld station and welded automatically. The other method of putting stiffeners on was to locate up to four stiffeners on a plate using an Ogden gauging mechanism and weld the stiffeners simultaneously to the plate. This plate assembly was then joined together with other plate assemblies to form a panel. This method eliminates the manual layout, fitting and tacking of stiffeners to the plate. This is a very efficient method and should be considered in NASSCO's plans for any upgrade to our facilities.

D.) Jigs & Fixtures:

Most yards utilized jig pin platens. Those that did not are contemplating installing them. Those without jig pin platens make extensive use of permanent jigs and fixtures. The Quincy yard probably utilizes more fixed jigs than any other yard. However, they too are very interested in procuring a jig pin platen. The best looking and functional pin jig platens were seen at Ingalls and Newport News (both are under roof).

E.) Approaches Taken to Solve Space Problems:

Bay Shipbuilding has used a unique approach to providing additional production area. They have converted a bulk ore carrier into a fabrication shop. The ship has been outfitted with bridge cranes, press brakes, shears, punch presses, and work tables. Also, Peterson Builders utilize an old car ferry as warehouse space.

F.) Manlifts:

All yards are making extensive use of manlifts for welding, painting, blasting, etc. Most yards purchased these lifts, but several are leasing. At Bath they claim the use of manlifts has cut the cost of staging in half. Our observations lead us to recommend that NASSCO test the present unit or rent another for a trial period to determine their value.

G.) Methods Used to Increase Building Position Through-put:

There are several techniques in use by different shipyards that drastically increases the building position through-put. The most noticeable techniques in use are as follows:

The simultaneous construction of deck housing and hull. The deck house is fabricated, painted and outfitted on a platen, while the hull is fabricated in the building position. After launching the hull, the deck house is then lifted aboard. In order to accomplish this, a crane with a capacity to do the lift would be required.

Large unit construction utilizing the present smaller assemblies to fabricate jumbo units possibly weighing up to 800 tons. Again, in order to do this, the crane lifting capacity would have to be increased to handle the larger units.

Complete outfitting of large units on the platen. This is being done by Bath Iron Works with tremendous success. They go as far as to utilize the installed lights for production lighting. Their outfitting even includes the installation of file cabinets.

The general theory of ship construction used by Bath Iron Works and Levingston is to do all that is possible on the platens where it is the most economical.

H.) Japanese Technology:

After observing Japanese technology, it becomes evident that it is only good old American ingenuity and technology put to work and refined by the Japanese. There are people at NASSCO with ideas for production that match or possibly exceed the Japanese technology. We should examine very closely what is being done at Levingston with Japanese technology, with particular emphasis on results. For example, Levingston's line heating operation does not, on the surfaces, appear to be as good as NASSCO's present method of operation.

I.) Long-Range Facility Plans:

Bath Iron Works has already instituted a long-range facility plan utilizing input from Marketing, Production Planning, Facility Engineering and Industrial Engineering. The plan has already saved B.I.W. approximately 5 million dollars by following the plan. Their plan was based on three scenarios: all Navy, all commercial and 50/50 split. They did not consider repair operations.

Peterson Builders are utilizing the services of a consulting firm, Shipbuilding Consultants, Inc., to develop their long range facility plan. This firm has extensive experience in the ship building industry. It is a possibility they could be used to review the development of our plan.

J.) Conclusion:

After touring the various shipyards, it is our conclusion that all the yards accomplish their mission in the same basic manner. It is recognized that some yards have more advanced facilities in one or several areas, but lack efficient facilities in other areas of the yard. This appears to be the result of upgrading facilities with the highest priority for improvements in equipment and methods to reduce manufacturing costs.

SHIPYARD..... **Todd Pacific Shipyard Corp.**
LOCATION **Los Angeles, Calif. on San Pedro Harbor**
CONTACT..... Richard Gordon, Chief Martie Engineer
SIZE YARD..... 90 Acres plus *additional Land* located
behind steel yard.
EMPLOYMENT..... 3.,600

Points of Interest

1. Utilize plasma **N/C burning machines.**
2. The welding of aluminum deck housing for guided missile frigates is done with heli-arc
3. Pipe storage is very typical of what we have seen here at NASSCO and other shipyards. They tend to store at ground. level. They do not use any type of racks..
4. Pipe Shop has a pipe bender which has a capability of beneding up to a 12" diameter pipe. They do have an over-head monorail system within the shop for movement of material. This has elimated forklift traffic within "the shop.
5. Observed a bow section being positioned on a guided missile frigats It was a neat fit, no trimming was necessary.
6. They do provide shettered employee eating areas, similar to the ones in use at NASSCO. Also their restrooms are in fixed locations. They use very few portable toilets.
7. They have sufficient office space and are currently only using three trailers. They are remodeltig the third floor of a warehouse for offices Which will provide approximately 50,000 square feet.
8. They do have an employee suggestion system for safety and production improvement ideas. This has purportedly been a very - beneficial program Todd.
9. The transportation of large assemblies in the yard is achieved with the use of flat bed transporters. the whirley cranes only traverse between the ways and
10. In the Sheetmetal Shop they have a *Whitney* Panel Master, CNC controlled (Westbghouse 2560) , with plasma arc cutting capabilities.

E

11. The layout of material is done with templates and drawings. The drawing is made up by the Mold Loft with dimensions for the layout man to use.
- 1.2. The steel yard material handling is accomplished with a forklift rather than by magnetic cranes.
- 1.3. The steel is moved to a Conveyor by forklift then shot blasted and primed. It is then removed from the conveyor by magnetic crane and stacked. A forklift then transports it to the place of need.
14. The panel line is directly linked to the burning machine shed by conveyor. The conveyor has a 90° turn utilizing a transfer table consisting of a series of air Cushions. The panel line has no sophistication, fitting and layout is all done by hand and the weld units are suspended from a gantry. This be does force production line assembly by having each operation performed at a particular work station.
15. Todd does not utilize pin jigs, they are using fixed jig set-ups.
16. They do have a totally contained blasting facility. It was in operation and we could not get inside. It is a very facility and could not handle large units.
17. They have two building positions, inclined ways. The capacities are 800' x 84'. Two large bridge cranes straddle each ways plus two whirley cranes at the ways with a 175 ton capacity each.
18. Two floating drydocks are used. One can accommodate a vessel 700' x 86", the other can accommodate a vessel 550' x 80'. Crane service to the drydocks is provided by two 35 ton whirleys. Currently one of the drydocks has an LST in it for modification. This is about an 8.9 million dollar contract. The other drydock (wooden construction) is of 1918 vintage and currently is under remodeling.
19. There is about 4,800' berthing space and all serviced by 35 ton whirleys.
20. This yard in the past has basically been a repti facilities and are gradually trying to turn the yard into a new construction facilities.
21. They do have considerable area for expansion as the majority of material is stored at ground level. Within the main site there is considerable open space. plus a large section of land is located just behind the steel yard for future expansion.

- SHIPYARD Livingston Shipyard - subsidiary of
Ashland oil Co.

LOCATION Orange, Texas. On the Sabine River
30 miles inland from the Gulf of Mexico.

CONTACT Luther Hashaw, Facilities Supervisor
Bob Taylor, Industrial Engineer Suprv.

SIZE YARD. 100 Acres and currently using only 80
acres.

EMPLOYMENT 2,000

Points of Interest

- 1.. The first things that we noticed as we came un to the shipyard was that they do not have any parking problems. They do have considerable amount of in-yard parking.
2. Livingston is basically in the construction and repairs of off-shore drilling rigs. To date they have built 65 drill barges, 25 tenders, 10 drill ships, 10 jack-ups and 6 semi-submersible. They are currently working on a contract for five 3.2,000 DWT bulkers. This is in conjunction with an IHI contract. This is the largest ship to date that they have built; They also have jack-ups currently in production: there are two under construction at the present time. The length of the ways is 1,200' in length. They currently have one bulk carriers siting on the ways that will be launched may 17, Saturday. To one side of this a mid-section of another bulk carrier. As soon as this one is launched they will proceed on the second one. A third carries will then be started as soon as the May 17 carrier is launched.
3. The deck housings are built separately and not built aboard the ship. They are built off to tile side an a platen and completely built up and outfitted. This outfitting includes electrical, venting, crew's quarters and the bunks. When they set the deck housing up they lift it up by two elevations. We noticed that the piping on the deck housting does run through the split elevation. To accommodate erection, pipes are burned and then re-fitted when erected aboard ship.
4. Crane capacity in the yard is geared to the typical unit 40' x 40' and 40-50 tons. ^{Maximum} lift capacity on land is 110 to 120 tons. They do have four Derrick barges ranging from 40 tons to 400 tons capacity.
5. Inner bottoms have neat fit on one edge only with all other edges with excess.

6. Current productions projections are: Three jack-ups per year, two 35,000 DWT bulkers. They hope to increase this to four jack-ups and three 35,000 DWT bulkers. Presently on the ways there is a 35,000 DWT that was started in February and will be launched on May 17. It is scheduled for delivery in October, 1980. The mid body section is consuucted and later the stern and the bow is to be assembled to it. At this time the deck housing is being assmbled on a ptaten. The only preoutfitting that they do as far as the engine room is a pumping" section. They are working out other means of preoutfitting.

We did observe the jig pin platen. It is nothing Speceacular . It is basically raised off the ground about three to four feet. There are sliding pins with adjustable screw pin on the top. (Exhibit-A)

8. *Levingston* is utilizing line heating (IHI Technology). Normally heating is done to straighten, but the Japanese have revrsed it and the heat reacts to the steel to form a shape It is not an investmerk in equipmnet but in training of the people and using the Japanese techniques . They had a foreman from the Japanese yard come over and **work with the employees for about** four to six months.
9. We did observe the panel line. A new system which is not currently operating. The brand is Ogden and is basically four stations. The first station is the magntic hold down. They put the plates down in position and then tack them. The plate is advanced to the next station which is sub-arc, which is mounted on a gantry. The third Station is a suffener balding device that positions the Stiffeners and tacks them. They are then advaced to the next station. Four longitudinals can be welded at one time. The panel line will eventually have a plasma planner feeding the plates to it in the near future.
10. Theblast and primer operation uses a monorail system for plate movement. The plates hang from the monorail up to 126" wide. Any wider they have to make two passes. It goes into the primer area and is manually applied. The primer they use is made by International. It is called Interplate, QA 200 zinc sulfete, #2437. They are currently using two painters that have been there for seven years. They wished they had a horizontal set-up. They dye the primer different colors for different ships so that they can distinguish between the ships..
11. We noticed they have several production foreman offices spread throughout the yard. Basically a structure 6' x -6' with windows all around. This was designed by the president of the company. It is quite a nice office for the formen. (Exhibit B)

12. Their steel storage yard is something like NASSCO's . They stack much the same as we do. They use a magnetic crane for handling the material. The steel does come in by truck . They have the possibility of receiving material by barges which they have not done as of yet.
13. They have realized the need for standardization through the IHI program. They are performing an extensive standardization of buliding numbers and steel plates and anything else they can possibly standardize.
14. We did notice the restroom faclities are permanent in nature. They do have an indooor eating facilities which . they claim is not used that much. P e o p l e generally eat in their production area. They do have picnic tables scattered throughout the yard.
15. The pipe shop has a monoril running throughout the shop and then branching out to each work station. Their pipe bending capacity is four inches in diameter. The majority of their piping is flanged. They have palletized rack for movement of pipe in the yard It is built with 2" diameter pipe. It holds three paliets side by side.. It is used for transport and storage. (Exhibit C)
16. They have no problems with offics space in the yard. They have a building with a top floor empty and have a problem deciding who to put in it.
17. They look for no Navy work and do not desire any. Their number one objective is to have centracts with jack- ups and then dry bulkers. Repair, jack-ups and then bullkers are in the order of priority when work is in-yard.
18. Their Repair facilities at Port Arthur is going to have to be moved. The land that it occupies is owned by the railroad and they will be moved off that sike by 1983. They already have a new sight located just across the river in Louisiana. They will actually start from a green field. This is a great opportunity for them to proceed with a new layout. All of their repair operations will be performed at this site. current employment is 600.
19. They are extensively utilizing the **transporter they purchased from NASSCO and are-very pleased with it.**

3. Last September they had a hurricane here which caused ten million dollars worth of damage'. The hurricane damaged their trailer facilities, offices, had gantrys blown off the tracks and toppled over. They had bridge cranes demolished and roofs torn off buildings and their power was knocked out which caused considerable problems with production. They had to use power sources off the ships and instead of going from shore to ship, they went from ship to shore and they just recently got back on their feet.

4. The steel yard had an overhead crane similar to NASSCO'S using magneks and it has a 20 ton capacity. They lift the plates off barges or rail and then store the steel in stacks. They do use a colacater system to deliver the material from the steel yard to the fab shop and at that time it goes through a shot blast and then on into the fab shop for flame planning for the panel line or then cut into various shapes for their curred units.

5. They have a shapes storage area which is else fed into a Shapes shot blast and then into the fab shop. Currently in their fab shop they have three NC flame planning machines and are definitely going to be going in the near future into plasma and CNC.

6. At the currernt time there is an office building under construction that is two stories with 100,000 square feet. We learned from Norm that this will not meet the requirements - they will need another 100,000 square feet of office spats.

7. The panel line is in a building and is 1,000 feet in length. The material is delivered to this building on transporters and then is unloaded from the transporters to a storage pile and then to the panel line by a 20 ton magnetic bridge crane.

The first station of this panel line is the fitting area where they use a magnetic hold down. The tacks are 12" apart and the tacks are two to three inches in length. Then the panel is transported on down the panel line to Station 2 where they weld side 1 using sub arc's mounted on two gantrys. The sub arc machines are capable of laying two seams at a time. In the same general area they have an overhead bridge crane which has the capability of flipping the panels over and then at that point they are able to weld the second side.

After this station - Station 3 - there is a turning table which allows them to rotate the panel 90 degrees if required for positioning stiffeners.

At Station 4 they have two large longitudinal positioning gantrys which feed from the outside as the building position longitudiaals then a flux core welding machine welds the longitudinal to the ganel at the same position. The next station on is where they would put on the stiffeners, girders and bulkheads and after this there would be a variation of stations, thers is 500 feet of the panel line that is left for this type of operation. But as the panel continues on down the panel line it then becomes a completed

unit and at the end of the panel line, there is a 100 ton capacity bridge crane that transports the completed unit from the panel line on the pedestals and then a transporter lifts the panel off the pedestals and transports it over to the shot blast area. The shot blast facility is an enclosed room within a building and it is lined with titanium steel and rubber pads. It has an overhead crane which has a 100 ton capacity but they actually run a maximum unit of 80 tons into it and the 20 tons then allows for the collection of Shot.

One thing that we learned, is that they have a very high maintenance cost facility and at the current time have it for down for 6 weeks for major repair. The unit is ~~basically a self-destructing unit~~ ~~They do not use pre-co~~

8. They are tending to get away - from shipbuilding - they are going in to the oil ~~industry~~ requirements which is submersibles and jack-ups - these are drilling platforms. They indicate that there is a definite requirement for this type of production. It appears that the oil industry is putting more emphasis on a quick delivery at the sacrifice of increase costs. Ingalls has set out to capture their share of the market.

9. Their employment now is currently down to 11,000. About a year ago it was double, but one thing to note here is that their profits are up.

10. They only provide lockers and shower facilities for the people with the dirtiest jobs. They have fixed lavatory facilities on the premises and we did not notice any type of portable facilities at all.

11. All material after blast and paint is delivered to one of five construction bays and each one of these five bays is a progressive assembly line where the unit is gradually built up from the inner bottoms on up to the upper deck, and then integrated to the launching area and on to the pontoons. Bays 1 and 2 in the future are planned for tanker type work or Navy work. 3 and 4 bays are going to be concentrated on jack-up and bay 5 will be for submersibles. They are really quite flexible..

12. They have a jig pin facility that is of excellent design. The pins are sort of a tripod shape and the first extension has rings every one to two inches apart and this allows them to raise it one inch or two at a time and has a collar which clamps in place and holds it.. The final adjustment is a fine screw type point which will then allow it to adjust within 1/16 of an inch or less. (Exhibit E) Their jig pin platen is under roof.

13. crane capacity at this yard is from 25 tons up to 200 tons.

14. They claim- to be able to produce a Sprance class Destroyer every six weeks.

15. They indicated that their procedure for neat fit and excess --- material in unit is as see in Exhibit F.

16. On a panel or unit assembly they have two sides for a neat fit and on the opposite sides have an excess of one inch. on their foundation on the base there is an excess of one inch On the bulkheads the top is neat and the bottom has an excess of one inch for trim. At one time when they started this shipyard went to neat fit all around and then they found out that they ended up having a ship 8" shorter than what they had planned on.

SHIPYARD . - - - . Avondale Shipyard, A Subsidiary of
Ogden Corporation

LOCATION - - - - - New Orleans, La. , on the Mississippi River

CONTACT - - - - - Dick Price, Plant Industrial Engineer
ollie Gatlin., Vice President of Engineering

SIZE YARD - 228 Acre Main Site

EMPLOYMENT - 6500

Points of Interest

1. Their Pipe Shop facility is currently under renovation for the change over to the new ultramodern pipe Shop. Right now in the older section of this facility they are using a bridge crane the full length of each bay that service the bays and at each work station they are using 1 ton jib cranes. Eventually just about all of this will be out and a new Pipe Shop will just about to-tally take over the whole area.

The new Pipe Shop has been designed by a company named oxytec. is a German company and they have just installed their painting system.. They should be ready by October 1st or sometime thereafter to start the line The pipe is delivered to the shop by railroad cars and use a crane to load on-to a loading platform and then is lifted by elevator up into a multilevel storage rack system. The pipes will be segregated by size up. to 8" in diameter, then the pipe is automatically selected out of the rack and lowered and brought down to a conveyor and fed into the shop. At this point it does go into an external blast facility and then is transported by conveyor to the next station, which is an interior blasting, then progresses on to the paint systems. After painting, it is fed out to a conveyor and is either transferred to a transport car which will bring it back outside for storage, or it will continue on in the shop to the next stages of production.

They were not on site, but they will be using two Conrae bending machines, one a 6' and one a 10".

Their palletization of piping is done on wood pallets and is about the equivalent length of 3 standard wood pallets. pipes are stacked or just piled on and secured with metal bands.

2. The Sandblast facility is a large building with a series of rooms. The first room is basically that, it is just a room where the sand blasting takes place. The sand blasting is done manually and the room has the capabilities to handle two assemblies at one time. The units do arrive into the room by way of a transporter on railroad tracks, then lifted from that on to the pedestals for blasting.

The next stage is in room 2 which is the clean and touch up of the units and from that room it progresses into the painting room. They do use manlifts for blasting and painting the units.

The fourth room is the drying area with one end open. The unit is then removed with a self-propelled transporter.

3. The panel line is an ESAB-HEBE. The first station is fit and tack. They use magnet hold downs and they tack every 12" using a mig gun for tacking. Then the unit is transported on rollers to the next station where the seams will be welded up using a Tandum sub arc mounted on a gantry. Two of these machines have the capabilities to weld from the center out to the edges. This gantry is also on tracks which can be moved up and down the panel line

The next station is a turn over station with overhead bridge crane which can flip the panel over 180 degrees, then coming back to weld side two using the same weld gantry as they use for side one.

The next station is a rotation table which can rotate the panel 90 degrees.

The next station is where they position the stiffeners. The stiffeners are fed in off of holding racks and positioned using hydraulic rams and horizontal adjustment clamps. The stiffeners are held in this position and then the overhead weld machines that are on gantries move into place and weld up the Longitudinal.

Then the panel is lifted by overhead bridge crane and transported down the bay to the appropriate assembly position on the platen. The T-Beams are fed to the panel line via conveyor. On this conveyor system they have a punch to do rat holes. Then it progresses into a shot blast area which strings off the edge of the T-Beam. It removes the primer before welding.

4. They do not use a jig pin system. All their curved units are built in stationary fixtures. At one time they tried to use the pin jig system and production refused to use it.

5. Preconstruction primer - They do use a preconstruction primer but the areas where welding is done the primer is removed. On the panels they use a homemade belt sander to strip the area where the welding will occur, and use a blasting machine to remove the primer off the edge of the stiffeners. I noticed that the primer would rust on them and they do totally shot-blast this preconstruction primer off in their shot-blast facilities.

6. Avondale does have its own steelyard that is off-site and provides steel to the yard and to other vendors. At this site they do receive it by barge and then is transported from this site to the yard by railway car.

Their steelyard on site uses the same stacking system and dunnage as NASSCO. They do have two magnetic bridge cranes. The make is Via Nova - same as NASCO's. They also have a general storage area which is set up similar to the steelyard.. This is used just for storage of parts.

7. They use portable restroom facilities with holding tanks. These are transported quite frequently all over the yard. All they really have to do is just pipe water to them and plug them in. They are put aboard ship. They have shower rooms and locker rooms only for a very few people such as the shot blast personnel. The eating areas in the yard are basically under cover with picnic tables and they have a kitchen on site which is manned by an outside concern and they use substations for food distribution.

8. Their gantries are using hydraulic drive and they have stated to convert some of the swing units to hydraulics also. They have had very little problems with this modification:

9. Material Movement in the Yard - Material movement from the panel line or platen area to the shutblast is -done using a 160 ton railway transport car. Other movement of material in the yard is basically done on a self-propelled transporter which is of a 500 ton capacity and can be driven from either end. As far as movement of people within the yard, they have been using mopeds or Honda mini bikes and are starting to convert over to using bicycles because of the high theft rate of the Honda's.

10. The largest vessel that can be built is a 1,000 feet in length and 174 feet in beam. Their gantry cranes have capacities from 60 ton to 200 tons and they also have a 600 ton" floating lifting device.

11. The launching of the ships are either done by a side launch or a lateral movement of a ship into a floating drydock. Their current production is on tankers, barges, drilling platforms and tugs. They have two different docks, one is 900 feet by 260, has 8100 ton lift. The floating dock is used in launching and is available for repair. They have one other dock that is used for repair only. It is 224 feet by 80 feet. Their berths are 600' and 1,200' and approximately 3600 feet of pier space.

SHIPYARD..... Newport News Shipbuilding, a subsidiary
of Tenneco, Inc.

LOCATION..... Newport News, Va, on the James River

CONTACT..... Paul Kirkland, Manager of Plant Engineer-
ing, Bill Bradley, Project Engineer

SIZE YARD..... 475 Acres plus an additional 50 acres
currently being filled in along the
river

EMPLOYMENT..... 22,000

Points of Interest .

1. The yard is split into two areas the north and south yard. The north yard was developed solely for commercial work and was completed in 1977. The north yard actually sits on reclaimed land from the same James River of about 150 acres. The site was developed for large, jumbo tankers. They found out right after they completed it there was not really a market for that type of ship. The ideal ship is somewhere in length between 700' and 800' long.
2. The new building basin is probably the largest in the nation. It is 1,600 ft. by 250 wide and 44 ft deep. They are currently making accommodations for two gates that they can put in two different locations so they can block off the dock and be able to flood one portion while the other portion is in use. These gates will be located from the back end of the basin. One at 400 ft. and then the other location at 800 ft. These will give them flexibility so they can work on a multitude of different lengths of ships or whatever their need is at that time. They have a 900 ton goliath gantry crane which is approximately 23 stories high. The make on that crane is KRUPP. This crane services the building basin and a final assembly platen. The stands between the rails on this goliath is 540 ft. with a height clearance of 200 ft. Gantries also service this area. Two at 30 ton, one at 60 and one at 275 tons. (Exhibit-G)
3. Material is brought into the assembly area by transporter from the fabrication shop. The types of units that are brought in are anywhere from 50 to 100 ton sub-assemblies. Then they are fitted and welded to create a super structure. Also at this site they precutfit on the platen. The unit was built up from the bottom shelve to the upper deck. This type of unit could weigh 850 tons. (Exhibit-E)

4. currently in the building basin they were jumboizing two old tankers. They have cut them in half and were putting in new mid sections.
5. The assembly building had six bays, two bays were used for making submarine sections. They have another bay which had the jig pin platen area. It is a complete bay with posts that stand about 3 ft. high. A column slides out of the post inserting a pin through the column to hold the post to the right height having a fine adjustment with a screw type inch and half bolt (Exhibit I).

The next bay is assigned to web frame assemblies. At the beginning of the bay they had large burning table area All bays have a good flow of material, coming in - one end and then proceeding on down through the bay until it forms a completed unit and then on out.

Another bay was used for large girder construction. This bay was set up with a roller, conveyor so that the assemblies could be rolled to each work soon, layout, fit up, and weld

The panel line was in another bay. The panel line was a Esab-Hebe. when they first put this in they did not use it for about a year, because they did not have the required - It was actually built **for a jumboized tanker panels. It is currently** ~~overhead~~ for the work they need to produce. They can't outproduce the of the yard and therefore run it on an intermittent basis. When they put it in the original intentions was for one side welding but they decided they better think ahead a little and designed in a turnover station. They are currently doing two sided welding. The plates come into the shop, are stored at the head of the line, a magnetic bridge crane lifts places them on the panel line conveyor. Then they are fit up and tacked using a magnetic hold down device. They are using a mig gun for the tack welding. The tacks are about every 6 to 18 inches apart. Basically they are using a tack of about 1/2 tick in length and once in while throwing in a larger 2 to 3 inch tack. The panel line is then advanced to the welding area where they use a subarc mounted on a overhead gantry. They have a weld machine at each end of the gantry. Basically they will use one at a time. It has a total of six heads on each machine. After that it is moved down and turned over and then it goes back to the same gantry for welding side two. After this the panel is advanced to the next area where they can rotate the panel 90 degrees. After that they have an area where they layout for the stiffener locations and at that point they use a belt sander to remove the primer from the stiffener weld areas. Then it is advanced to the fitting and tacking station for stiffeners. The stiffeners are

fed in from the side on a mechanized conveyor at that point as the stiffeners come in they have a set up for removing primer from the edge that will make connection with the panel. It is a set up of a three wire disk one for each side and one on the top edge to remove the primer. It is then brought in and positioned. Hydraulic clamps hold the stiffener down and then they will tack it. After that the panel is advanced to the next station where they will weld the stiffener to the panel. The last station is the take off station.

The stiffener's are staged in the next bay over; being brought in by pallet loads. Each pallet is assigned to a particular panel. They can have up to as many as 9 panels on the line and will stage 9 pallet loads of stiffeners to handle the load.

6. The steel is brought into the yard by barge. It is unloaded from the barge with a magnetic crane, placed on a conveyor then is brought into the steel storage yard. They have two steel storage yards one for commercial and one for Navy work. They can transport the plate to either one of these steel storage yards by conveyor. The steel is then brought off the conveyor by Via Nova magnetic crane and placed in storage. Their ideal set up is that when it comes in it should be taken off and run through the shot blast, primed and then back to storage or if needed then to a shop. All plates and shapes are preconstruction primed. The process is to run the shape or plate through the wheelabrator and primed with an automatic system. They use many different varieties of primers depending on what is called for on the specs. They did say they use International primer at times. The units in the yard did appear to be rusted up quite a bit. They did admit that basically they are re-blasting the unit again to remove the primer before painting. They remove the primer wherever they weld. They say that it is almost impossible to hold to a 3/4 mil thickness. It may be able to be obtained on a plate but when it comes to shapes it is almost impossible.
7. They do have some enclosed areas for smaller units. In these enclosed areas it is done manually but even though they have the areas the majority of the work is done outside because the workers prefer to work outside. The units are brought into these areas on railroad cars. The railroad cars are then covered up with tarps and then they blast the units. The larger units in the new building basin area are staged at the rear of the building basin and then blasted at night.

8. The restroom facilities are portable buildings and piped to the sewer. They are larger than NASSCO's designed portable buildings. As far as lockers and washrooms, they do not provide them although where you have a shot blasting and painting they do provide them.
9. Most Of their forming is done cold. In, osddr to do this they have press and roll capabilities. One ~~press~~ at 250 tons another one at 1,000 tons.. On their rolls they have one at 800 tons and one at 600 tons.
10. They do have some office buildings offsite. They have the engineering department in an office building about a mile from the plant. It two floor building, about 200,000 sq ft Also on the same location they have a recreation facility which include a gymnasium, football field and tennis courts. They also have an administration building offsite, just across the street from the yard. It is a six story building. The sixth floor was originally designed for the president and vice president but the president declined and wanted to remain in the yard and currently this top floor is used as cafeteria facilities and meeting rooms.
11. Transportation within the yard is basically- done with automobiles. Not personal automobiles but **company cars for in yard use only.**
12. Material transportation in the yard. They do use self propelled transpers of a capacity of 300 tons each that can be coupled together in order to handle units up to 550 tons. They also use railroad cers quite extensively through the yard for transporting material. They have some trailers that can handle units up to approximately 50 tons. They have quite a few forklifts also.
13. At Newport they do use manlifts extensively. They are not an exception, every single yard we have visited utilize these manlifts 50 the Utmost. They use them for all types of operations, i. e. , sandblasting painting, welding burning just about anything you can think of. We did notice that Newport News had a manlift on a barge and they were using it along side the ship for work. In fact, in most of these yards I have seen very ,litle scaffolding used.
14. In their south yard they are undertaking a major expansion. It will probably be completed somewhere in 1985. Currently they are building a new building basin which will accommodate a ship up to about 800

ft. long. They figure this is where the market will be. They are going to replace all wooden piers with cement piers. They learn their lesson with one wooden pier they were going to rehabilitate and by the time they were through they found out it was cheaper to put in a concrete pier. After that they will also modernize **their existing graving docks**. They will install some large **capacity cranes** at these drydocks and the piers.

u . **They** have three foundries. They **say they will** probably never get out of the foundry business. It has been profitable for them and they do **have the requirements**.

16. **The south** has **five** inclined ways, which can accommodate **a ship of up to** ft. by 125 ft., two ways at ship size of 715 by 125 ft., two ways at ship size of 715 by 93 ft. and **one** at ship size 447' by 93', and the last building ways could handle **a ship of** about 649' **in** Length. A couple of these ways were built back for World War I. They also have two building basins that can **accommodate up to 1,100 ft** by 136 ft. and 960 ft by 124 ft. The south yard also has three graving docks that can **be** used for new construction, repair work, or conversions. They have an approximate berthing space of about 12,000 Lineal feet. These piers are serviced by cranes up 140 tons.

SHIPYARD----- Norfolk Shipbuilding and Drydock Co.
LOCATION----- Norfolk, Va., Located on the Elizabeth
River
CONTACT --- Grimsted, Mechanical Equipment Manager
George Curtis, Facilities Manager
SIZE - - - - - 120 Acres
EMPLOYMENT--- **2,500**

Points of Interest

1. It is one of the largest ship repair facilities on the east coast. NORSHJPCO is capable of constructing large ocean vessels. They also build quite a few barges and do conversion work.
2. In February, 1979, they completed an expansion program which included a steel floatig drydock. It is the most modern in the world. The drydock is 950 feet long, 192 feet wide, and 160 feet between the wingwalls. The drydock has a lifting capacity of 54,250 long tons with 4,000 tons of residual water and one feat of free board.
3. El Paso made a six year contract for annual repair with them on LNG Takers. This repair work at one time was done at Newport. News and they Lost it to NORSHIPCO. This contract helped justify their drydock.
4. They do have a Building Ways which can accommodate ships up to 475 feet in length and 85 feet wide until they are ready" for launching. They have two older floating drydocks, one handles up to 640 feet x 88 feet. They have four marine rail-ways. The largest accommodation is 441' x 64' and lifting capacity of 5,500 tons. They have 12,000 feet of berthing space consisting of 14 piers.
5. The reason for visiting this yard was to take a look at a piece of equipment for Wayne Crutchfield. The machine is called NORSHIP Flying Machine. This can be lowered into a hull and holds two people. They have been using this for about ten years and has saved them considerable labor. It has two winches on it and by using" one winch to lower it into the hull and **rehook the** other winch they can **actually walk** it into the hull. They, *therefore*, need *no* scaffolding. NASSCO should try making something like this or purchase one from NORSHIPCO. (Exhibit J and K)

SHIPYARD ————— Sun Shipbuilding and Drydock Company, a
Subsidiary of Sun Company

LOCATION ----- Chester, Pa., on the Delaware River

CONTACTS ----- Mike Blackburn, Industrial Engineering
Supervisor
Jim Deacon, Engineer

SIZE YARD----- 200 Acres

EMPLOYMENT----- 4,0.0.0

Points of Interest

1. The current method of blasting units is outside. They have a blast and paint facilities under construction and will be in operation next week. The two cells are 80' x 80' and is all manual blasting and painting. A unit will be transported into the building upon a **transpoter** and placed on stands. This will place the **Unit** about eight feet off of the ground. They will have to use stanchions to clean and paint the unit. The building was just a concept about a year and a half ago. The cost of this will be \$7,500,000. They will be using a G-25 grit for the **blasting operation**. They are presently using a pre-Construction primer. All that is needed is a **sweep blast** to clean **up the surface** of a unit before it is painted. The basic process is that the unit is sweep blasted and then painted all in the same room. They have room for two additional cells. The equipment and systems within the building have back-ups so that if one goes down they can Convert over to another system. This way they will never be totally shut down. Vacuum and collection systems are made by a Danish outfit, Munkeboeholderfabrik. The blast hoppers are made by a company called Clemlo Industries. The *building* has other rooms in it which is a paint storage room, mixing room, utility rooms, locker rooms for women and men, offices, lunchroom and control rooms.. The manning of this facility is about 45 people and will probably reach 70. **See Exhibits L to R for sketches of blast and paint facilities systems.**
2. They are currently using pre-construction primer. They started out using Amaron DSPM and from that they switched over to Hemphol 1577 which they are currently using. It looks like it does a good job. They are getting good welds results. This primer has only slowed the welding down from 39" a minute to 36" a *minute*. They are testing an international primer NQA-203 phosphorus type of primer. They do not remove the primer where they weld. The only thing they have to do before painting is a sweep blast operation.

3. Material is moved about the yard using railroad cars and transporter. It has a capacity of 225 tons. They do use some flatbed transporters and extensively use *manlifts* for blasting and painting.' They do not own any of them they are all leased. Before *using the* manlifts, they apply 40 to 60 mils of paint booth peel-off for protection and when they turn them back in they just peel off the coating and the dirt and grime comes off. This way the unit shows very little wear and tear.
4. Instead of having a building basin they have a slab they build the ship on. They have hydraulic pushers that once a ship is built they push in on a floating drydock and lower and float the ship out of the drydock They are currently adding onto this level shipbuilding platforms to increase their capacity to 1,000 ft.
5. **Their current employment is 4,0'00. The interest in this is** that back in World War II their employment was 35,000 and they had 32 ways that were capable of launching a ship every four days. Currently out of those 32 ways they only have four left. Two are active and two are inactive, plus the two new level platfmorms.
6. **They** have a new *Engineering* and Management Building. It is on the site. It is a two story building. It is 120" x 350'. They still use trailers quite extensively in the yard.
7. Their foag is done cold using presses and rolls. They do stress relieve on the stern sections of a ship using a furnace with approximate dimensions 20' x 20' x 80'.
8. **Their type of work is** roll-on and roll-off ships, medium sized tankers, and they are trying to get away from the repair activities. **They are** concentrating on new construction. They have built many other things in the past: pressure vessels, oil refinery equipment, chemical work equipment and wind tunnels. They have a drydock which is approximately five **years** old. The distance between walls is 240 feet and 700 feet long. The drydock is in two sections and can be split apart. One section can be lowered at a time. They can be spaced 20 feet apart.
9. They fabricate and outfit their deck house assemblies off of ships then lift them *on board* using an 800 ton crane. The crane is barge mounted and can be moved all through-out their outfitting and drydock area to service them.
10. The capital budget is \$12,000,000 for the past two years. Next year's budget will be down to \$1,000,000.

11 They are installing their panel line and should be in operation next week. The brand is TTS-Total Transportation Systems. This unit is about half the cost of ESAB and probably if they had their choice and money availability, they would have gone for the more expensive unit. The plates are brought into the panel line on a conveyor then are positioned in station #1 which is fit and tack. Then they use hydraulic rams to hold the **plate** and they use **a mig gun for** tacking. **Station #2 is** for butt welding. The sub-arc machines are mounted overhead on a gantry. Currently they have one gantry and are planning on adding another gantry at a later date. As for rotating the panel 90 all wheels on this conveyor rotate 360° and that gives them the option of turning 90° at any location that they want. The next station would be the layout of the panel. This is done manually. The next station is where the stiffener would be located on the layout marks. There are no hydraulic rams to hold it. They tack it *using a mig gun.* *The panel will then be advanced to the next station for welding of stiffeners.* This consists of two separate gantries, each having a sub-arc welding capability. **They have also two** additional gantries. These are used for welding smaller miscellaneous parts. They have *another* device which will be used for holding the bulkheads so they can fit them and tack them. This is a complete and total assembly line from beginning to **end.** **They** have **a** feeding line for stiffeners, including tables for **cutting** and notching.

SHIPYARD ----- Quincy Shipbuilding Division- General
Dynamics Corporation

LOCATION ----- Quincy, Mass. , located on the Fore River

CONTACTS ----- Bob Graffe, Facilities Manager

SIZE YARD ----- 180 Acres

EMPLOYMENT ----- Not more than 1000 to 2000 employees

Points of Interest

1. The employment at Quincy (we did not get a direct answer) at one time had a high of 30,000 and last year it was at 6,000. They gave no comment on the current employment. From observing the yard there, it could not be more than 1,000 to 2,000 people at this facility.
2. The steel yard had two Via Nova magnetic cranes. The steel yard had gravel as a base and no dunnage. The steel is moved from the steel yard to a conveyor, then travels into a building through a deicer. Then through a wheelabrator where it could be primed or not primed. They had a separate yard for shapes. This had an overhead type gantry crane that would pick up the shapes and place it on a conveyor. Then the shapes would be run in through a deicer and then blasted and primed. The shapes ^{area is no-t} really functioning that much at this time because they have converted over to making their own shapes.
We did ask about preconstruction primer and they said they did use international chromemate zinc. From what we have seen in the yard there is very little preconstruction primer being used. in **fact**, there could not have been more than 5% of the material coated with preconstruction primer.
3. Their blast facilities were identical to Ingalls. There they would bring in a large assembly and hook it up from the roof and then close the doors where it would rotate. The blasting units are located in the floors, walls and ceiling and would automatically blast the unit. Ingalls said they had a lot of problems. These people said they have taken very little care of it and it is functioning. They do a lot of patching on the walls. They do not have rubber coated walls. It has been running for 10 years. There is really no complaints - it does do the job. Along with this they have 3 **other cells** in which the rooms are larger - where they can move any unit in and blast. This is a manual blasting operation, also they have two painting cells where they do touch up blasting and cleaning the unit and then paint. All these large units are brought in by self-propelled transporters. They have two of them in the yard at a capacity of 240 tons each. They also use railroad cars and flatbed trucks for transportation

of units in the yard. The design of their support pedestals for paint and blast allow them to be moved around without a forklift (Exhibit S) .

4. They do use manlifts expensively for painting and blasting wherever they can, so that they do not have to use scaffolding
5. They do not use jig pins. For shapes they use fixed jigs and they admit they are quite expensive, but they say this will allow them to have a neat fit.
6. Their forming is done cold and they do very little forming using heat as large rolls and presses are used.
7. Their steel fabrication facility included the panel line, angle fabricator, web fabricators and stiffener fabricator. They did not allow us to get a good look at this area. They fit and weld the stiffener to the plates first and then they weld the plates together to form a panel. They are using Japanese technology in one sided welding. They also fabricate Stiffeners by taking a plate, put the bars on it, and run *through* and weld it up and then strip them after on a burring table. They do have torches to heat and relieve the stress from the welding operation. They have four or five of these machines of different configurations. The name *on-these* machines is Ogden Engineering.
8. They have a 1200 ton *goliath* crane which straddles two building positions in an area where they can pick up units off the assembly area. This *goliath* was installed so that they could transfer 120 feet diameter LNG tanks from a barge and then place them onto the LNG ship.
9. They say they can produce 3 LNG ships per year and that's with a two year tool up.

SHIPYARD Bath Iron Works, a subsidiary of
Cengoleum Corporation

LOCATION Bath, Maine, on the Kennebec River

CONTACT Bob Bellonzi, Manager of Manufacturing
Engineering, John Mason, MARAD Program
Manag~--

SIZE YARD 30 Acre Shipyard, 25 acre fabrication
site

EMPLOYMENT 6,000

Points of Interest

1. **They** have a fabrication facilities **3 1/2 miles from tile** shipyard. This facility receives and stores all in coming steel. At this site the plates are cut to size, blasted and primed. They are then stored for shipment to the yard, by truck when needed. This plant is also used to fabnricate all small assemblies such as equip-ment platfoms.
 2. They use a vetical storage system for plates waitig transit to the yard. The placing and retrieval of plates is easy and allows for a high density of Plates stored in a rather small area.
 3. The transpotiation of units in the yard is accomplished by using flat bed trailers and one self-propelled transporter.
 4. The blast and paint facility consisted of three rooms, one for manual blast, one for Dainting and a drying room.
 5. They do not use jig. pins for curved unit construction But, utilize fixed jigs that bolt together so they can be stored without utilizng too much room. They are considering building a tig pin platen.
 6. They have an impressive assembly building. Where a unit is fabricated to pre-outfiting, they go as far as in-stalling file cabinets and utilize the installed lighting for production.
 7. The Last frigate they produced was 16 weeks ahead of schedule and 5 milion under budget. When they do this they give all employees a bonus.. They currently can launch a frigate every 15 weeks
-

8. The maximum ship size that can be built is 700' x 130' on ways B & C. The ways are serviced by a 200 ton IHI Whirley crane.
9. Bath already has a long range facility plan. The plan was based on three scenarios all Navy, all commercial, and 50/50 split. It was developed on input from Marketing, Planning, Industrial Engineering and Facility Engineering.

The plan has already saved Bath 5 million dollars by postponing the construction of 2 piers that they thought they needed.

The plan was based on a particular ship design, and used unit measures of lineal feet ducting, pipe, etc. to develop critical shop loads.
10. This year's facilities budget is 7 million.

SHIPYARD Petierson Builders Inc.
LOCATION. Sturgeon Bay., Wis.
CONTACT. Fred Peterson, II, Facilities Manager
SIZE YARD. 13 Acres main yard and 40 Acres for
future development.

EMPLOYMENT 950 @ shipyard., 30 @ **Plant:#2**

Points of Interest

1. *This yard is basically a **new** construcion yard and does not do repair work. They have basically four yards within one because of the type of vessels they build. They build steel, alumninum, wood and fiber glass vessels.*
2. *They have warehouses located throughout the city which contain about 200 ,00.0 square feet. Also a fabrication facity off site of about 4 5,000 square feet which consists of a plasma arc **burning machine** for cutting alumninum and steel. They do some steel or alumninum fabrication at this site and transport it to the main yard. They seem to own quite a bit of land in **and** around the shipard area. They also have anotther manufacturing facilities located a couple of miles away from the shipyard and they call it their Plant No. 2. It has nothing to do with shipbuilding. They are building tractor transpoters that are used in airports for moving jets in and out of position and they are basically an assembly operation for International Harvester.*
3. *The normal employment is somewhere between 300 and 400. This is a non-union shop and they do give bonuses when they make a profit and try to keep the employees happy and keep the union out.*
4. ***Their facilities consists of a 300 ton railway which can handle a ship up to 200 feet long, a floating drydock which can handle a ship up to 2,000 ton and 300' by 39 feet, two building docks that can handle vessels up to 300 feet. They have four berthing positons. They have a 60 ton gantry, and a couple. mobile cranes up to 200 tons.***
5. *They are currently **working** on tuna boats and they will fabricate the tuna **boats** inside in the assembly building and then tranport them in two different sections. into their painting facility and then join them in a building positon and then launch them.*

- 6 . They are currently building a new paint and blast facility. Currently they are doing most of this work outside and want to move it indoors. It consists of a building 120' by 100'. The paint booth is 60' by 100' and the blast booth is 60' by 100'. The paint booth area has water wash booths on the sides to remove the vapors from the air and they are using Develbis equipment. In the grit blast room they are using Clemco blasting equipment - the walls are lined with a tapered masonite to reduce shot damage. They will use a skip leader for moving the grit into the floor hoppers that will retrieve it back into the silos and recycle for re-use. To date they have spent \$625,000 on this facility and expect to spend only another \$25,000 bringing a grand total up to \$650,000 **for the facilities.**
7. They do not use a pre-construction Primer all the time. When they do use it, it's usually International. On the tuna boats they use no primer at all because they are using Fro-line paints..
- 8.. The use of jigs and fixtures is basically fixed jigs for their curved units. They do not have a pin jig. They could form their parts using two different presses - one of 250 tons and the other one of 300 tons. The only place they really use heat is on fairings.
9. All their employees are trained for more than one trade so that as the work load shifts from area to area; they can move the personnel around. This helps them from having to lay anybody off and it keeps a constant work force.
10. They do use manlifts for blasting and painting and welding and they use them quite extensively. In fact, they say they have proved that they have cut their **staging costs in half** with the use of manlifts.
11. **They** do not provide lockers or washrooms for the employees. As for office space, they are very constrained. They do have people throughout the Sturgeon Bay area in different buildings they have purchased from time to time.
12. **They are currently working on their long range facilities plan and have a target date of completion** at the end of this year. They are using consultants and the name of the consultants are Frank Rack and Gardner Parsons. These two gentlemen seem to be well versed in long range planning, and it looks like they are doing a pretty good job for Peterson. It

may be a possibility *that* we should use these gentlemen as consultants to review our plan.

They have made a model board **of the** Peterson yard and it is a **4 x 4 piece** of plywood with galvanized steel on it and has been painted to the color codes and the buildings are magnetic strips on the bottom of wood blocks so they can be moved around. Under each building the building number is painted and the building number is also on the wooden block. This makes it so they can shift it around a Picture of it as it is now, then do a proposed one for the future. We probably should do a similar type of model and develop a model board for the yard as it is now. and then we Can update the model board for the propsoed plan.. The cost of their board was \$.2,500.

SHIPYARD Bay Shipbuilding Corp. a Subsidiary of
Manitowac Inc.

LOCATION Sturgeon Bay Wis.

CONTACT..... Roy Aiken, **Operations** *Manages*, Dave
Koelling, Industrial Engineer

SIZE YARD 36 Acres

EMPLOYMENT..... 1500

Points of Interest

1. They do not use **preconstruction primer on their** steel.
2. *The* blasting facilities is a building *ag* on rails, this allows the building to be split open and the unit dropped into place. This was not an *endormmentally* controlled building, but is just protection from the elements.
3. They use crawler type cranes and transporter built by Manitowac for transportation of units within the yard. Also they have one barge mounted crane for outfitting.
4. Their steel is received by barge in the summer and by rail in the *wiater*. The steel is stored flat and also Vertically.
5. Their panel line is very similar to the system used at Quinoy. The equipment was built by Ogden. The method of panel assembly is to first *positon* and weld up to 4 stiffeners at a time to a plate then join two or more plate *asseblies* to make a panel.
6. The fabrication of curved units is done with fixed jigs and cold forming. They do have plans to build a jig pin *platen* in the future.
7. They have a very unique fabrication shop. Not because of the equipment but because they are using a bulk ore Carrier for the facilities. This ship has been outfitted with three exit ramps, *bow, mid section and Stern. Bridge crane rails run the full Length of the ship for crane service.* The equipment *consist-*ed of brake presses, punch *grasses*, burring tables, shears, and work tables.
8. The *fabrication* shop had a new iron worker model KBL, size **71-5**, make Mubba, German made and distributed by E.G. Eellers, Tarzana, Calis.

9. Their production is 2 to 3 1000 ft. bulk ore carriers per year.
- 10• They are presently *Undergoing* expansion in the yard with the addition of new pier space. Their facility dry dock is 640' x 70' With a lifting capacity of **7000** ton. The building basin is 1,150' x 140'. The basin is split with a removable sea wall so part of the basin can be flooded and still have the back section dry. The Gate in the basin is hinged at the bottom. So when the Gate must be removed, it is just lowered to the bottom and then pulled back into place by a cable. The building basin and platen is straddled by a 200 ton crane. large units are constructed in the **platen then lowered into the basin ~~using~~ the crane to its capacity.**
11. The **deck** house is fabricated on the Platen and then placed aboard Ship after Launching. Other than the deck house very little *pre-outfitting* is done at Bay.

LEIVINGSTON JIG PIN PLATEN.

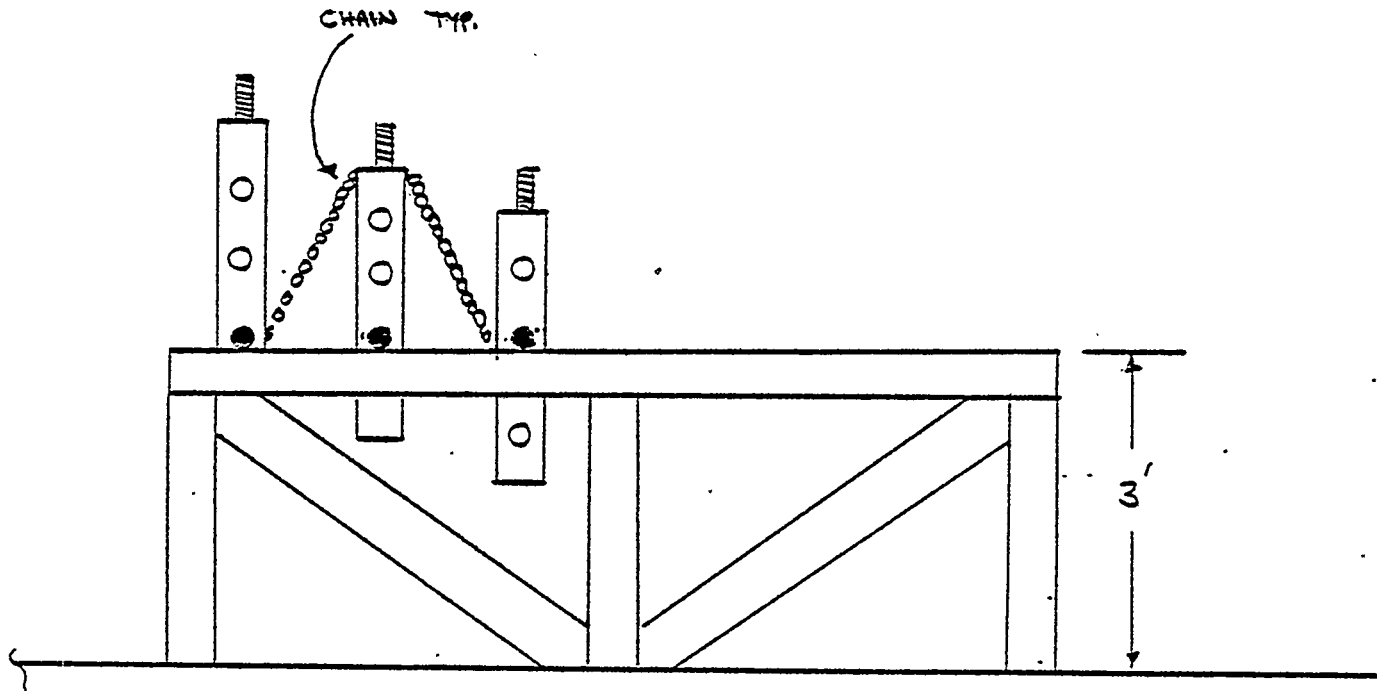

END VIEW

NOTE: ALSO CAN BE USED AS A FLAT PLATEN.

LEVINGSTON PRODUCTION SUPERVISORS OFFICE

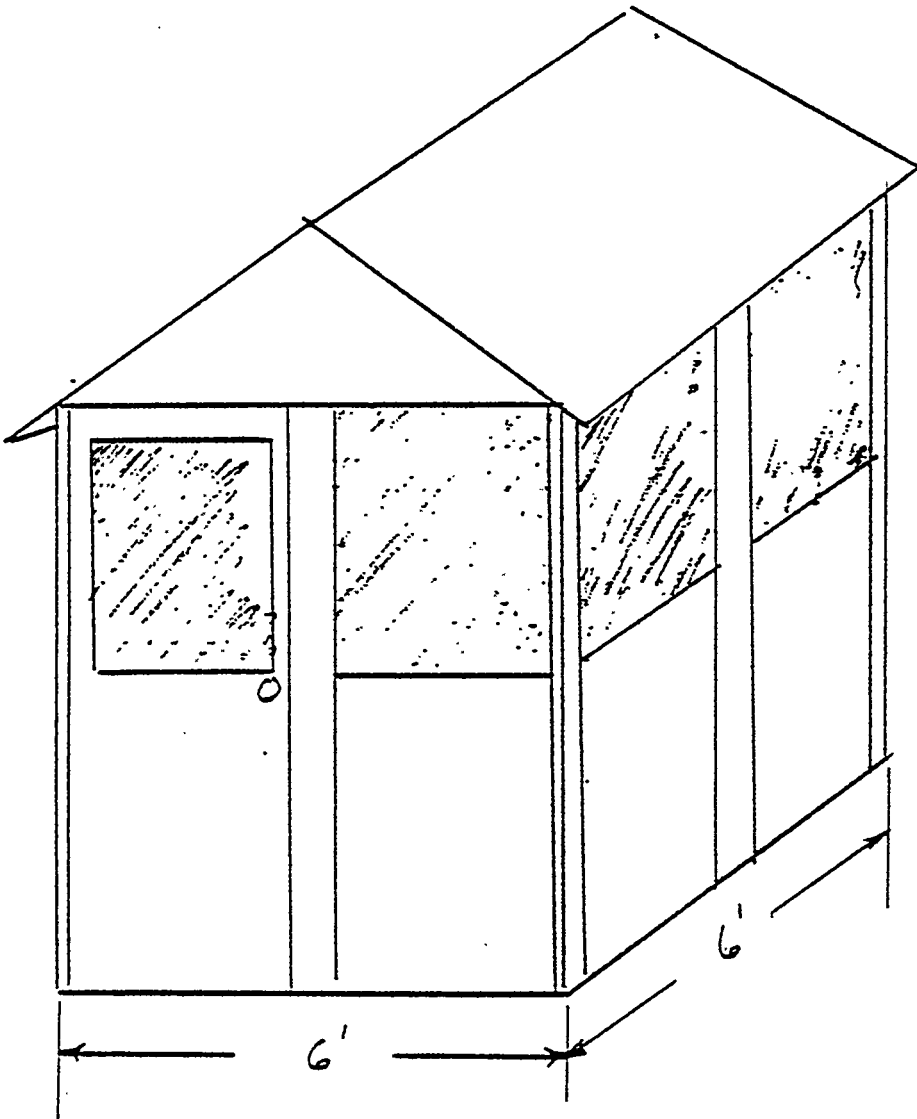

EXHIBIT-3

LEVINGSTON PIPE PALLET

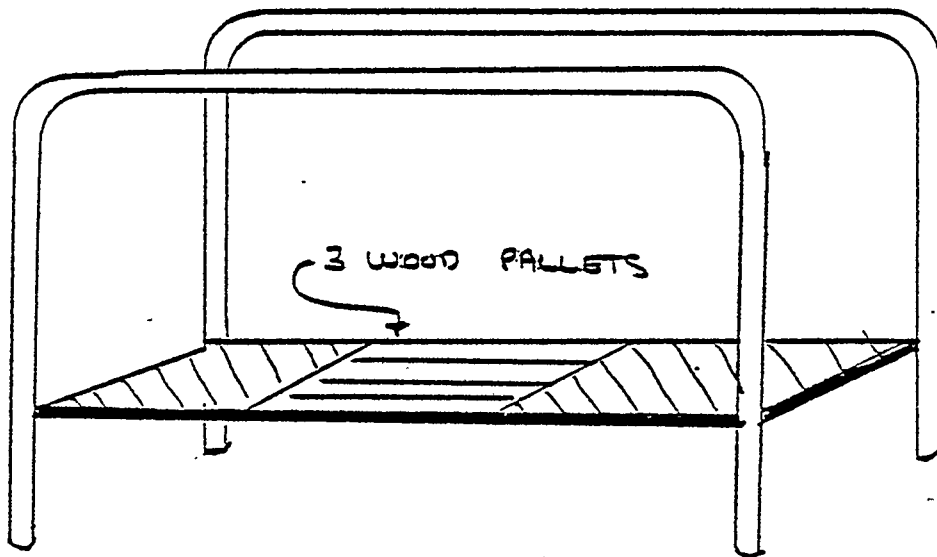
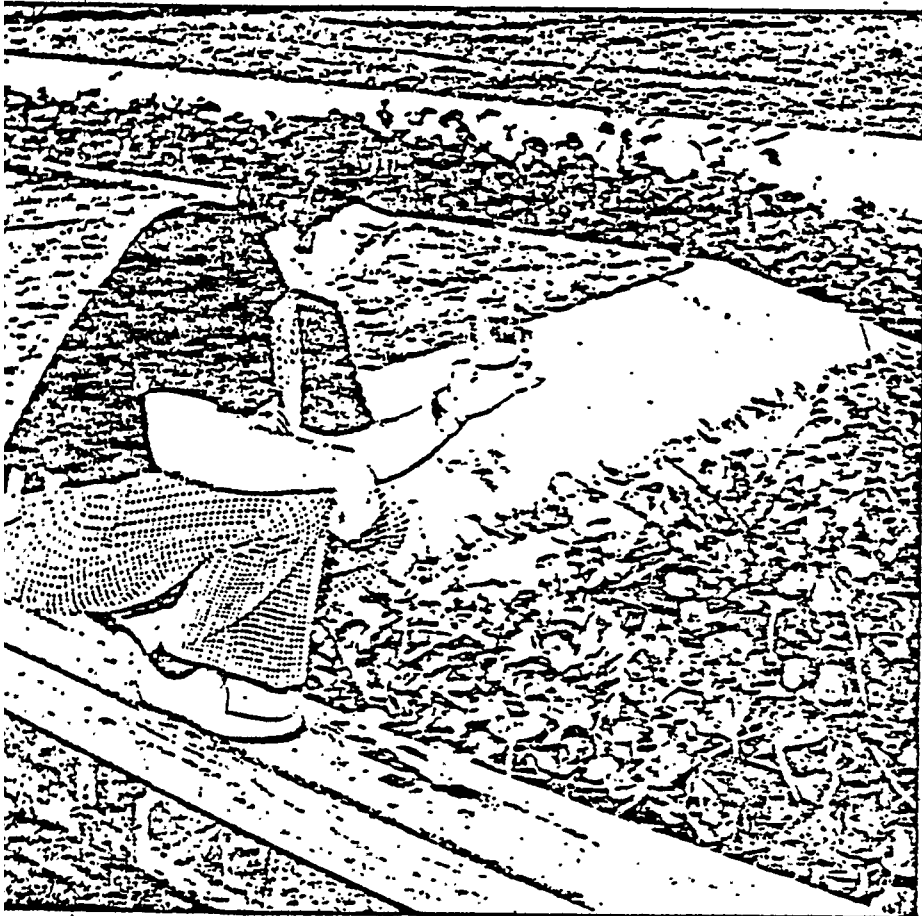

EXHIBIT - C

Wolverton and the Hyacinth Hypothesis



At the National Space Technology Laboratories, tests being conducted by Dr. B.C. Wolverton may soon change water hyacinths from foe to friend.

There's nothing particularly inspiring about his office. Hidden away in building 2424 at the National Space Technology Laboratories in Bay St. Louis, the office's biggest advantage is the scenic view it affords of pine trees and the placid Pearl River.

In fact, there is nothing particularly stirring about the site of the research biochemist sitting amidst the clutter in the office. His casual attire is covered by a slightly wrinkled white lab coat. He sports no Nobel prizes or presidential commendations on his office walls. He spouts no fancy phrases tailored to impress the less-than-scientific guest.

But on the wall there are several pictures of rampantly growing green plants. A box of crackers and a jar of peanut butter sit on the shelf near the door.

Really it's an appropriate setting for Dr. B. C. Wolverton. For while his name is not a household word yet, he is the unqualified Einstein of water hyacinths.

If there is one project that typifies the importance of NSTL to the man-on-the-street it is Wolverton and his water hyacinths. Unlike most people who find the wildly growing plant to be a pain in the neck, Wolverton sees in its leaves discoveries that could

ARTICLE FROM NEW ORLEANS MAGAZINE, MAY 1980

EXHIBIT - D

make expensive waste treatment facilities outmoded and supply energy enough to punch at least a small hole in the current crisis.

Water hyacinths multiply faster than the fabled rabbit. In the right conditions 10 of the plants can multiply to 600,000 in only eight months. They've proven to be a thorn in the side of government agencies responsible for waterways and have cost taxpayers millions of dollars to control.

Wolverton began his work with water hyacinths as part of the development of a closed space station where astronauts could live and work.

"There was a need for some green plant that would grow in raw sewage, be in a dynamic growth state, and also be a good food source," Wolverton explains.

Wolverton soon discovered water hyacinths met those standards. The plants can filtrate residual metals, chemicals, minerals, and other residue from ponds. They can then be harvested, the valuable metals retrieved and the plants buried.

"All of this isn't just a passing fancy or untried theory of Wolverton. He isn't merely a government scientist who just didn't have anything better to do.

Wolverton has developed a full-fledged waste treatment system at NSTL. Water hyacinth lagoons at the site successfully handle all the

facility's chemical and domestic wastes. Wolverton estimates the water hyacinth sewage treatment system has saved NASA \$1 million.

But there has always been the question, Wolverton says, of "What the hell do you do with all those water hyacinths?"

Now he thinks he has the answer. It's an energy farm, an idea whose time has come even if the support of bureaucrats is still pending.

It's really quite a simple concept.

It's an energy farm, an idea whose time has come even if the support of bureaucrats is still pending.

Wolverton says he has a way to fabricate methane, synthetic natural gas, from dried water hyacinths.

The energy farm, officially known as the Biomass Wastewater Recycling Demonstration System, works something like this: water hyacinths and two other plants, cattails and kudzu, are grown in a lagoon. Sewage is pumped into the lagoon. It is purified by the plants. Then the plants are harvested and put into a gas digester.

There the plants are converted into methane gas. The byproducts of the

conversion are used as fertilizer for the plants in the lagoon.

This is a simplified version of an energy farm, to be sure. But, according to Wolverton, it works. He says that out of every pound of the dried plants, some 3½ to 4 cubic feet of methane can be produced. That's as much as can be gotten out of a pound of coal.

The average American home uses some 20,000 cubic feet of methane per month. Wolverton figures one acre of the plants could produce enough methane for one or possibly two of those homes for a year.

"There's a biological revolution about to start out of absolute necessity," Wolverton says. "In southern Mississippi, Louisiana, and Texas where we can grow these plants well, we can create sufficient energy in the form of methane to supply a large portion of our energy.

"If it (an energy farm at NSTL) is approved with funding from headquarters, we'll do exactly that. We'll first prove the economics of an energy farm of 10-12 acres, then work out any problems and go on to 100 to 1,000 acres.

"Of course, it's a new technology, something entirely different and it'll take time to condition people to accept and understand it."

But if necessity is truly the mother of this invention, the American public may soon take a liking to water hyacinths.

INGALL'S JIG PIN POST

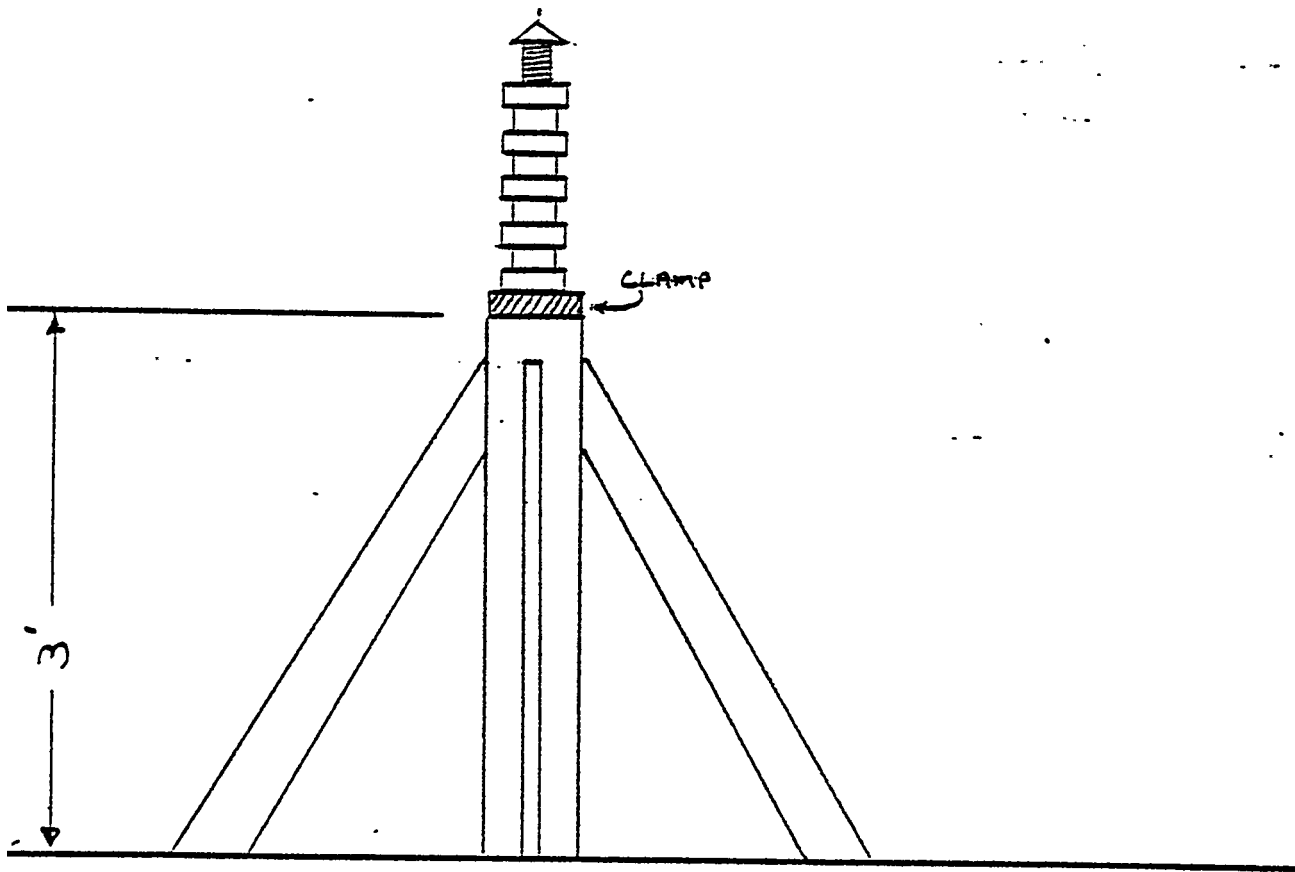
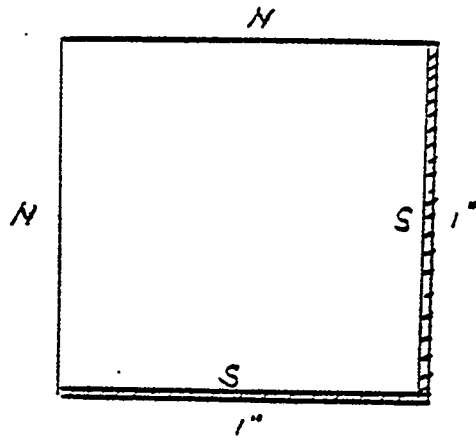
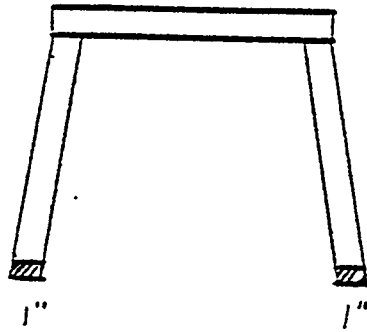

EXHIBIT - E

INGALLS NEAT FIT PROCEDURE



PANELS



FOUNDATIONS

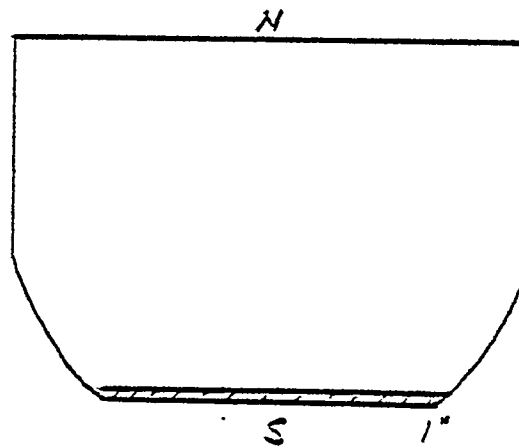

BULKHEADS

EXHIBIT - F

NEWPORT NEWS BUILDING DOCK AREA.

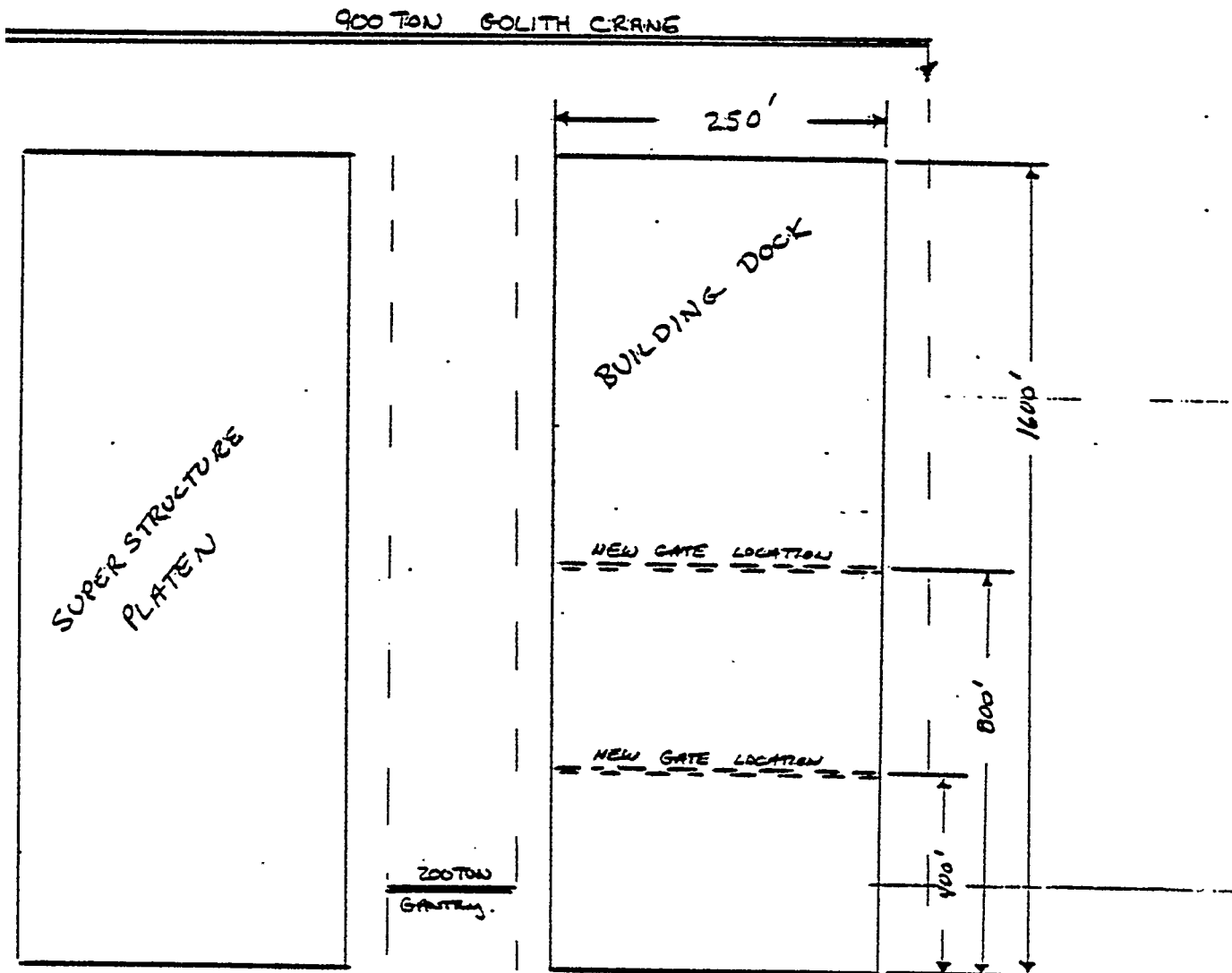

SHOT BLAST
&
PAINT AREA
(BLUE SKY)

EXHIBIT - B

NEWPORT NEWS SUPERSTRUCTURE

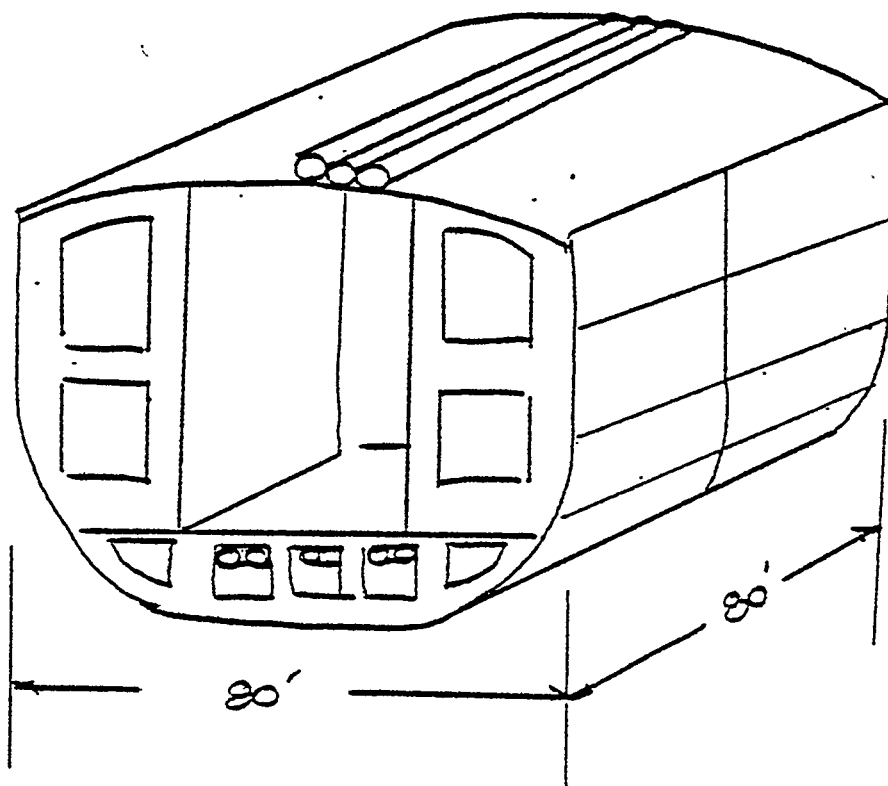

EXHIBIT-H

NEWPORT NEWS JIG PIN SYSTEM.

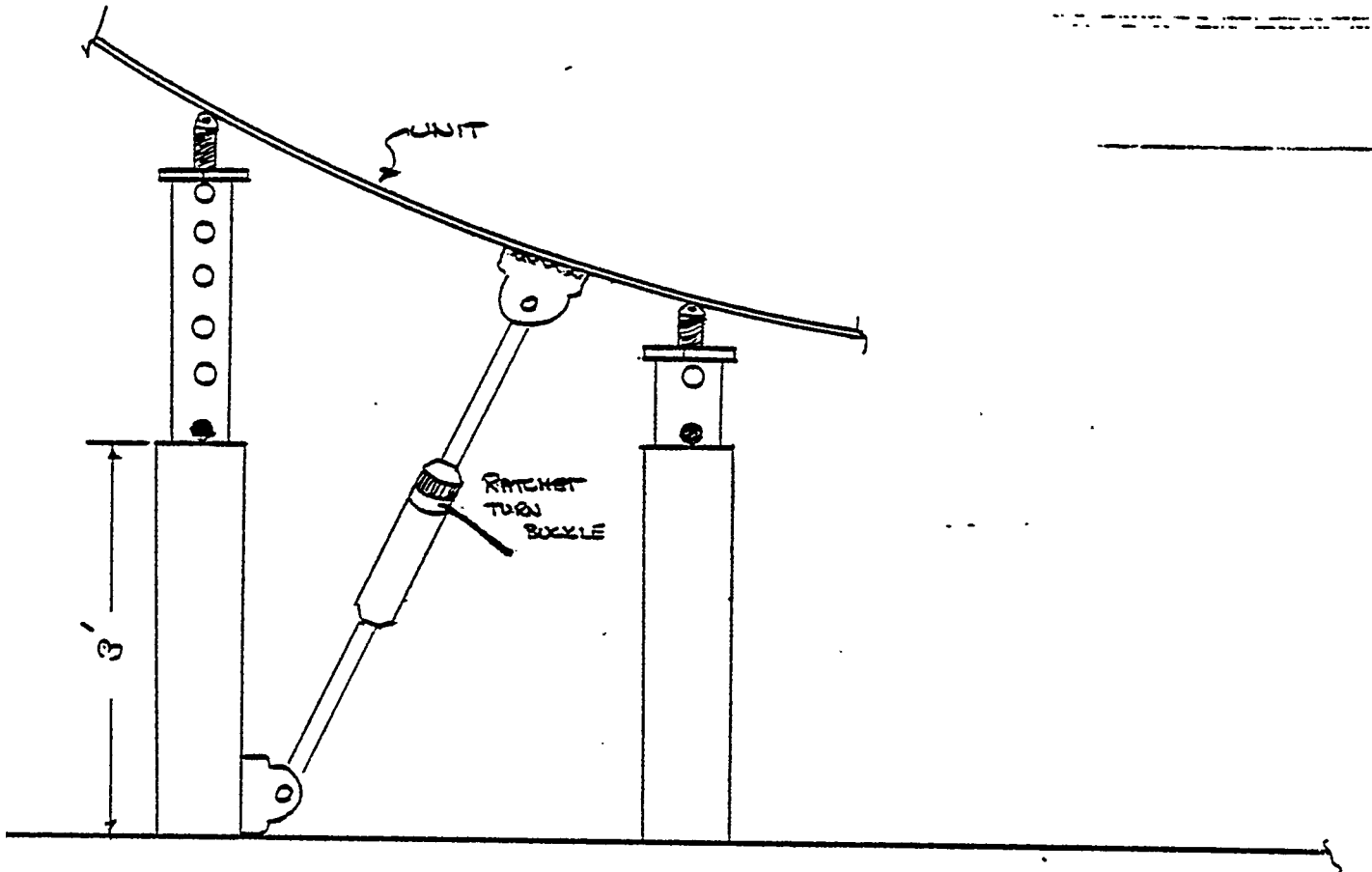

EXHIBIT-I



3 March 1980

NORSHIPCO FLYING MACHINE

I, would like to give you a little background as to why the flying machine (sky climber) got its start at Norshipco. Before the sky-climber came into existence at Norshipco, it was quite a job to get staging erected in the cargo tanks of tankers. In order to hang staging wires, it required 3 men to carry a sixty foot extension ladder around in each tank, and hold it in an upright position while a person hung staging wires from the overhead of each tank. This method was time consuming and very tiring.

I have heard quite a number of people stating, "Boy I sure wish there was another way of doing this job. "

Well, with a great deal of thought, one of the supervisors came up with the ideal machine. Norman Drake, a supervisor in the rigging shop invented the 'Norshipco Flying Machine. "

This is a piece of equipment that can be lowered into a cargo hold of -- a tanker. It consists of a center metal "T" beam, with two air motors attached with a folding metal platform, on either side of the beam, with saecy rails.

These platforms, will fold up in a manner to enable the machine to fit into a cargo tank of most tankers. Once the machine is lowered through the cargo hold, the platforms are extended to the open position. At this time it is large enough to carry a person on each platform. The persons in the machine are able to hang staging wires, by shifting one of the two hoist wires in holes in the overhead, traveling around the top of each tank, installing the number of wires required to stage each hold.

Staging tanks is where the machine is in most demand, but they have found quite a number of other uses at Norshipco, for this machine. It has been used in the erection of cranes and also their zeoair. In order to get the lower incline of the plant's water tower it was very helpful. The riggers at Norshipco find it useful in working on masts of ships, this gives more production time for cranes, it is used over the side at times, out most of all it has put the 60 foot extension ladder out of work in the cargo tanks of our tankers at Norshipco.

T. W. White, Rigging Department
Assistant Foreman

EXHIBIT - J

NORSHIPCO FLYING MACHINE

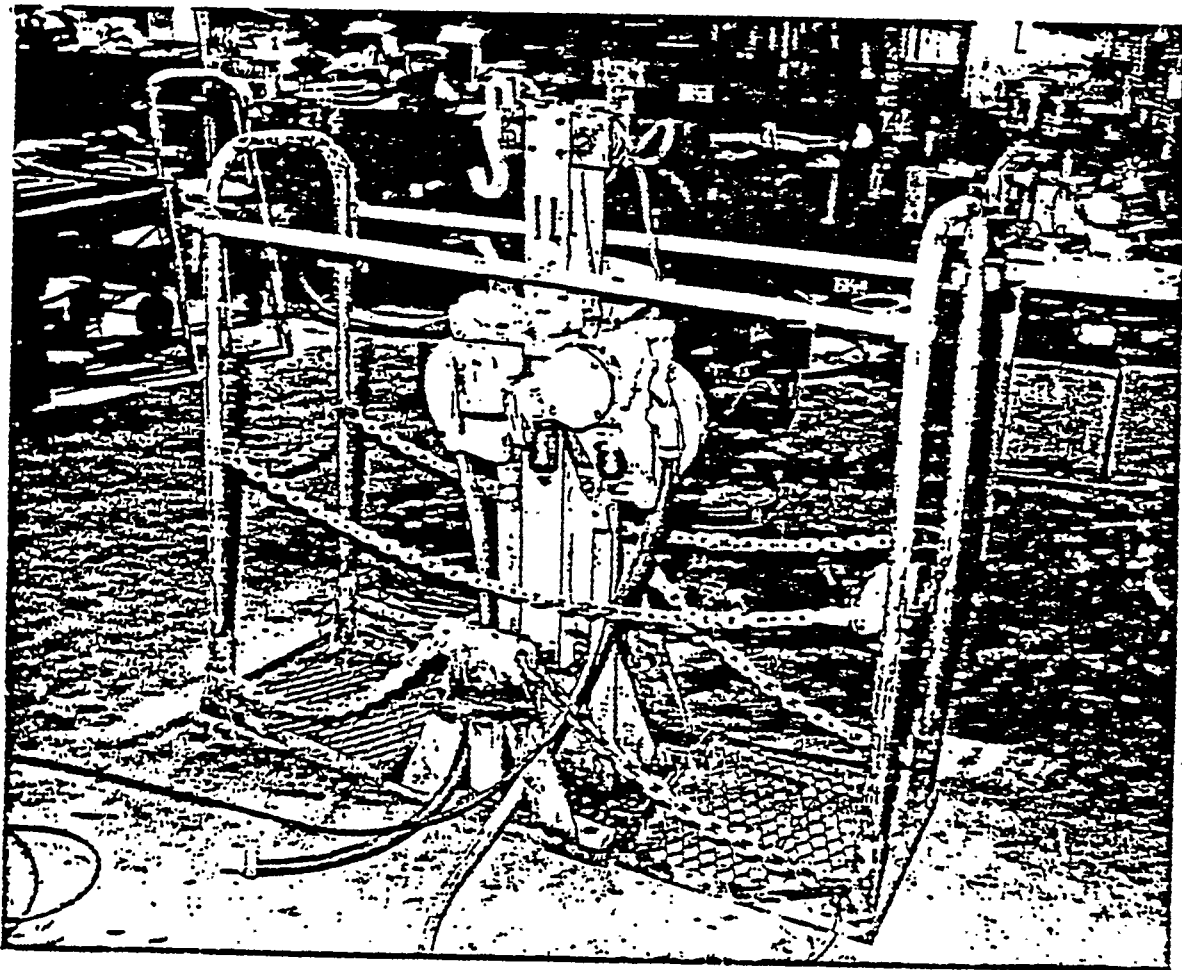
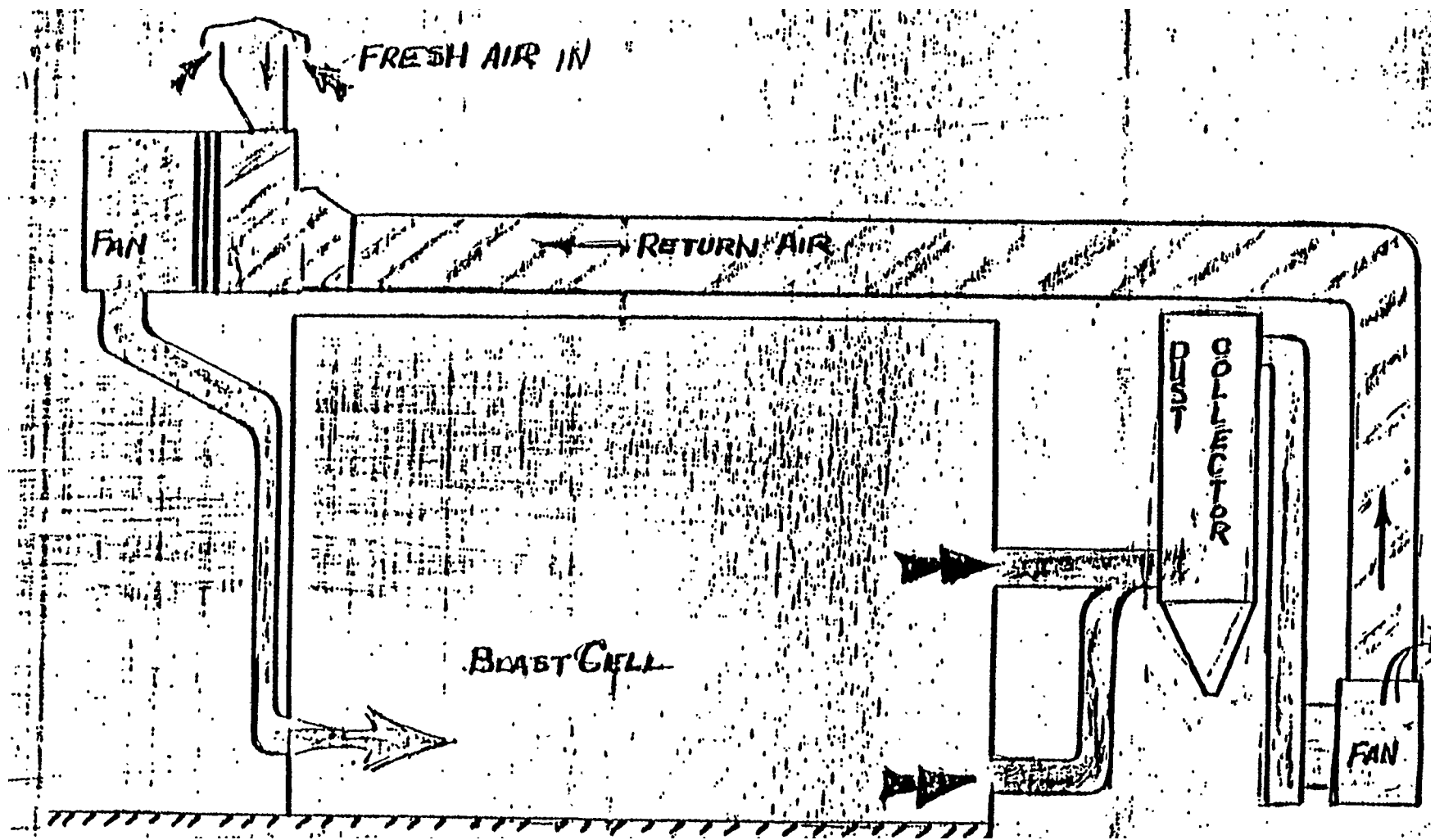

EXHIBIT - K



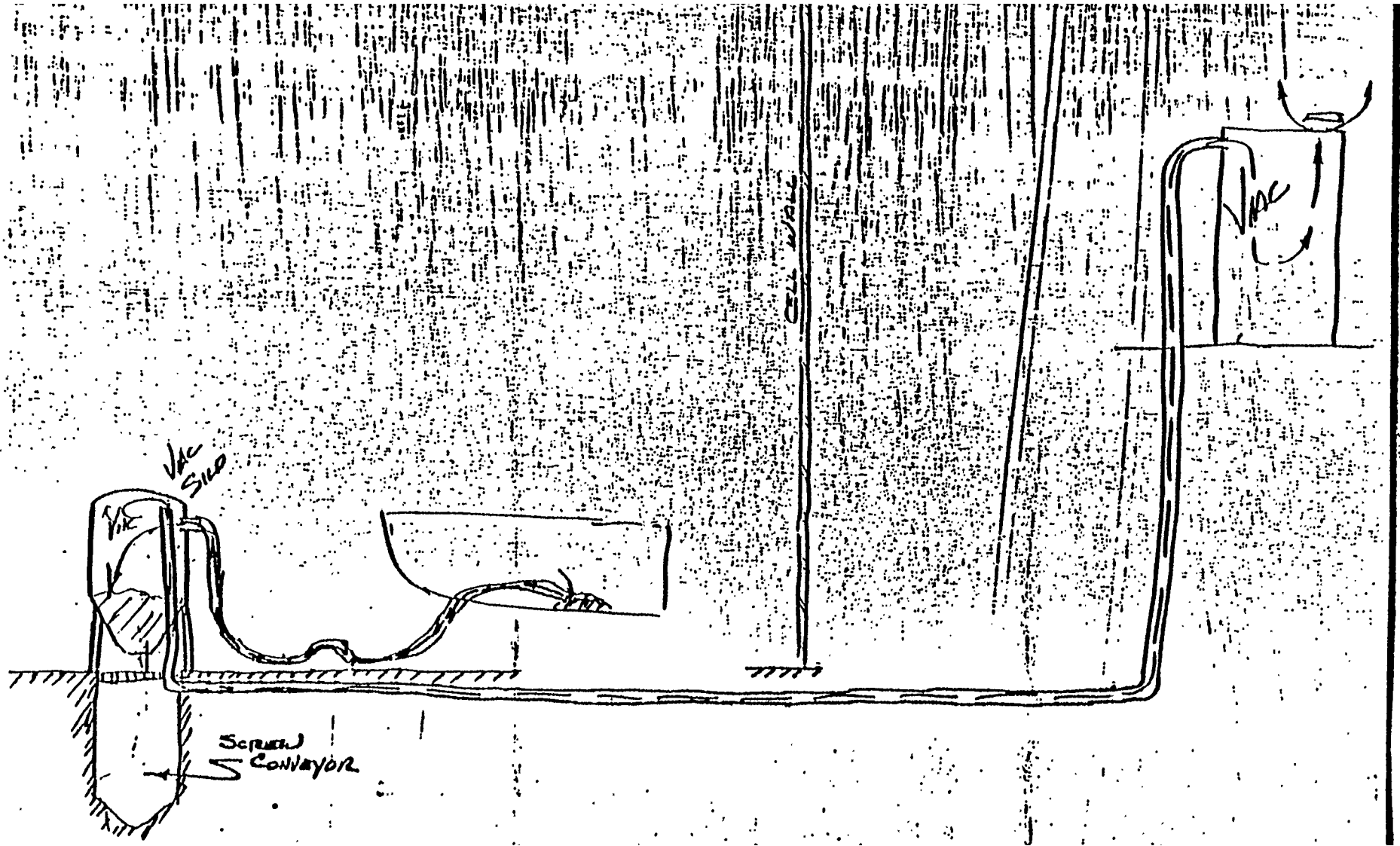

EXHIBIT - N

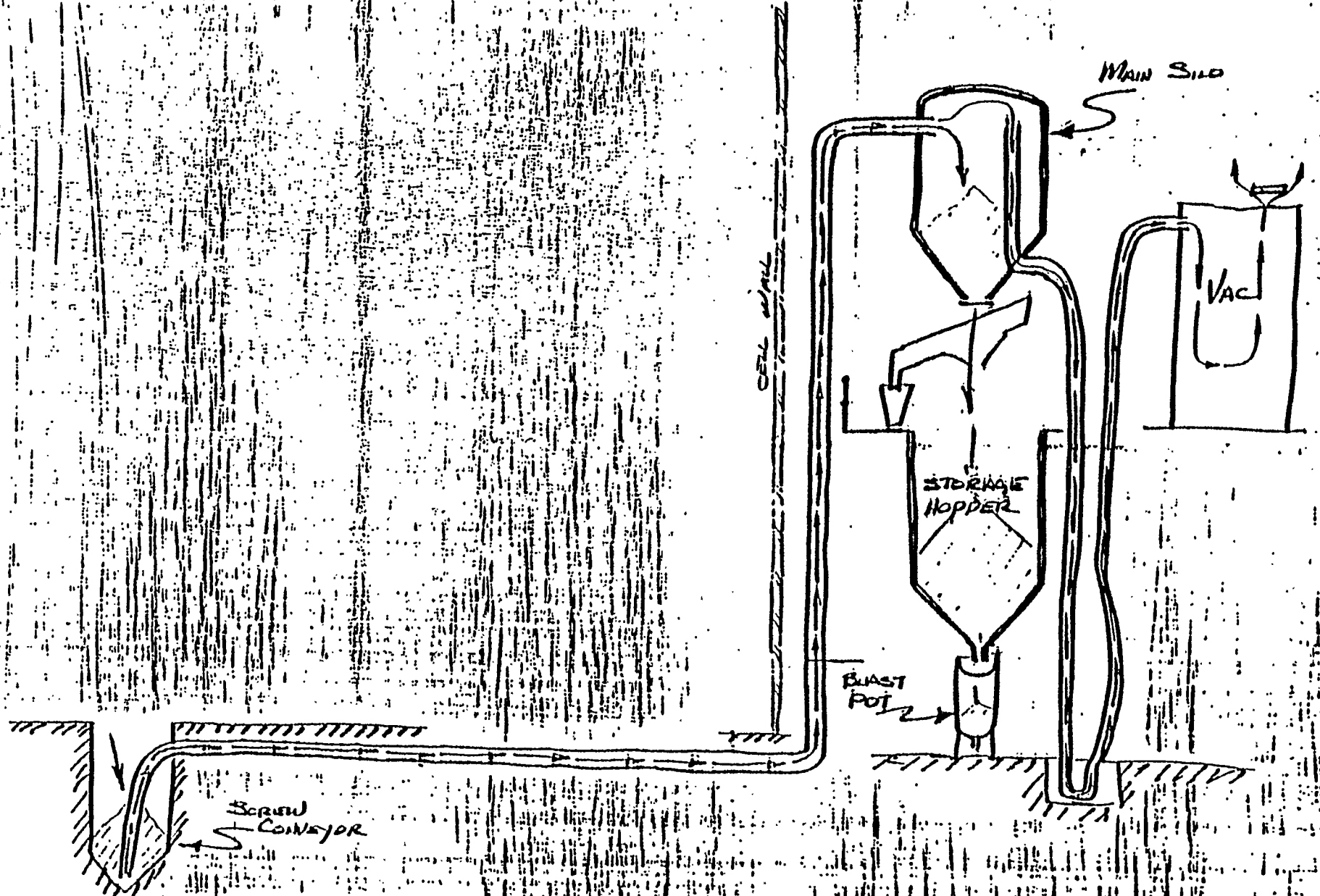

EXHIBIT - 10

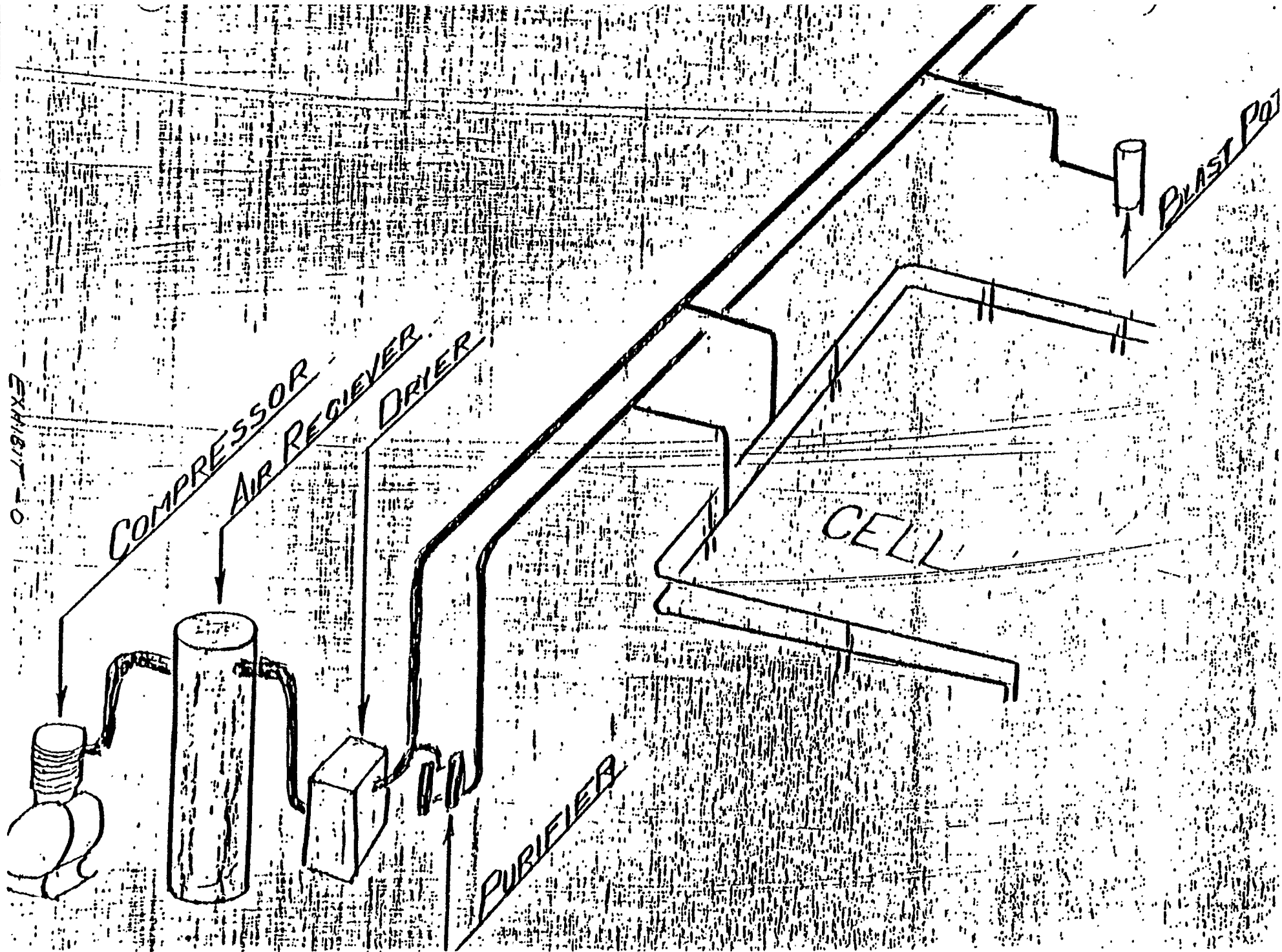

EXHIBIT - P

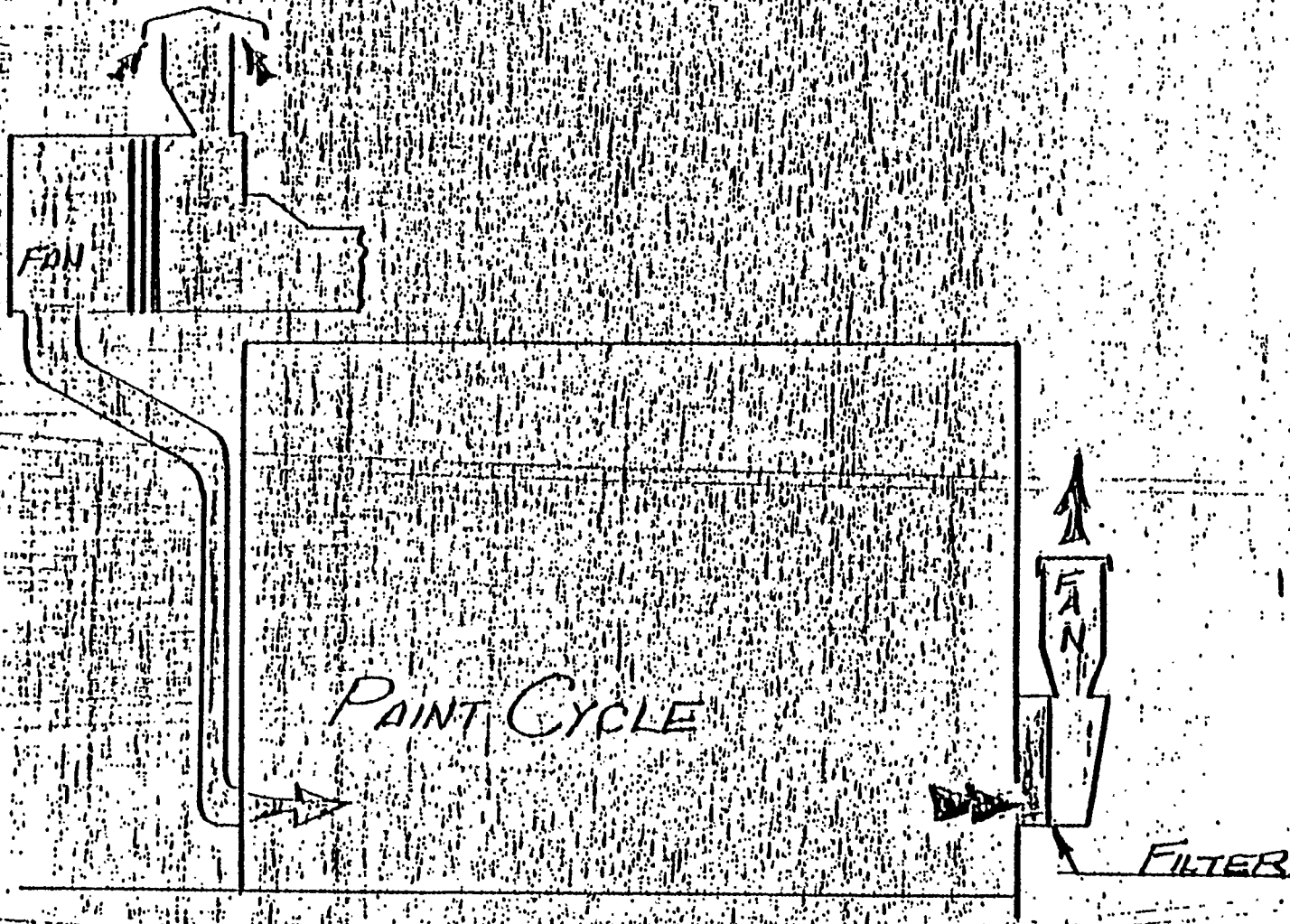

EXHIBIT - Q

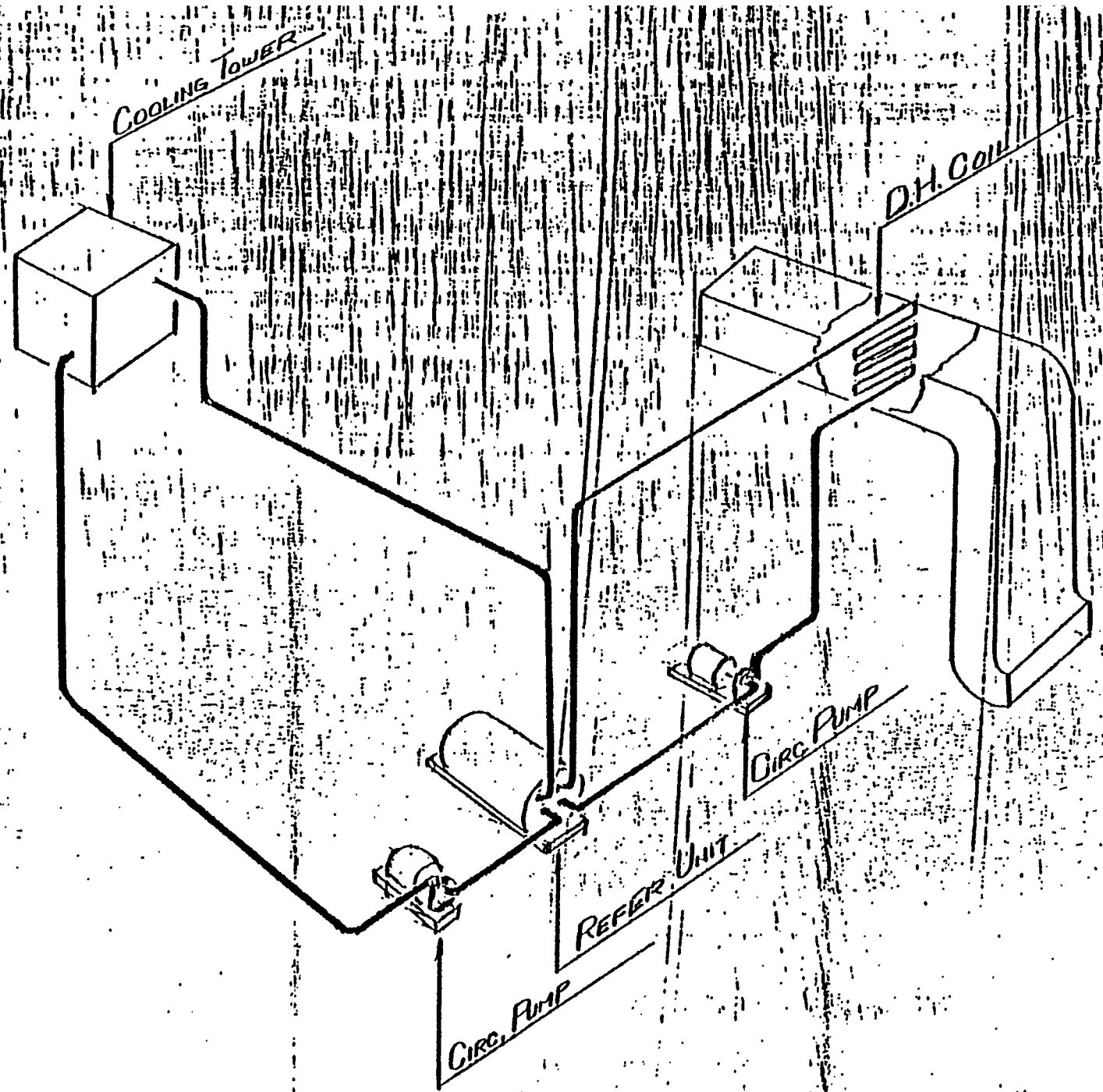
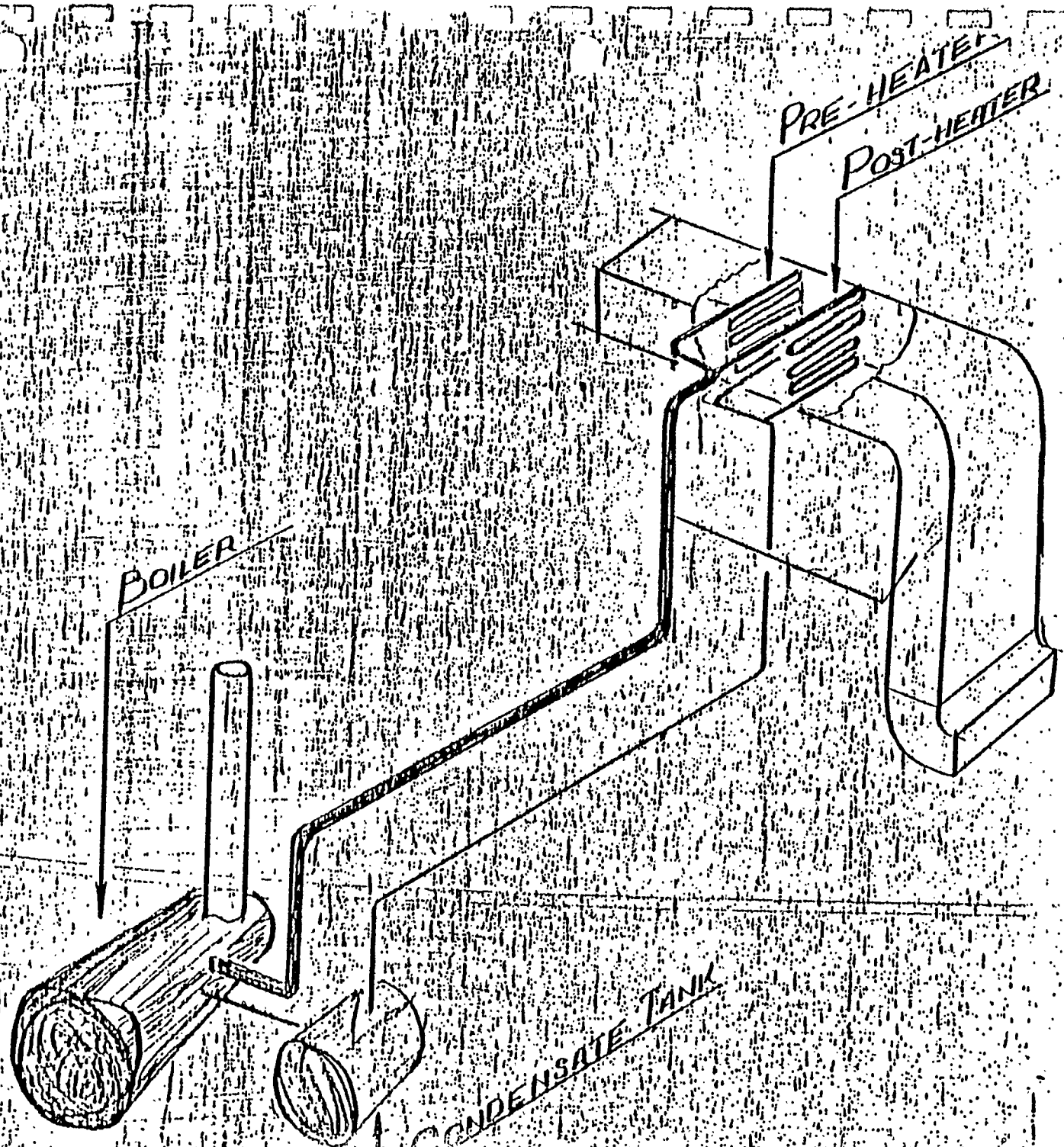

EXHIBIT-2



QUINCY SUPPORT PEDESTAL

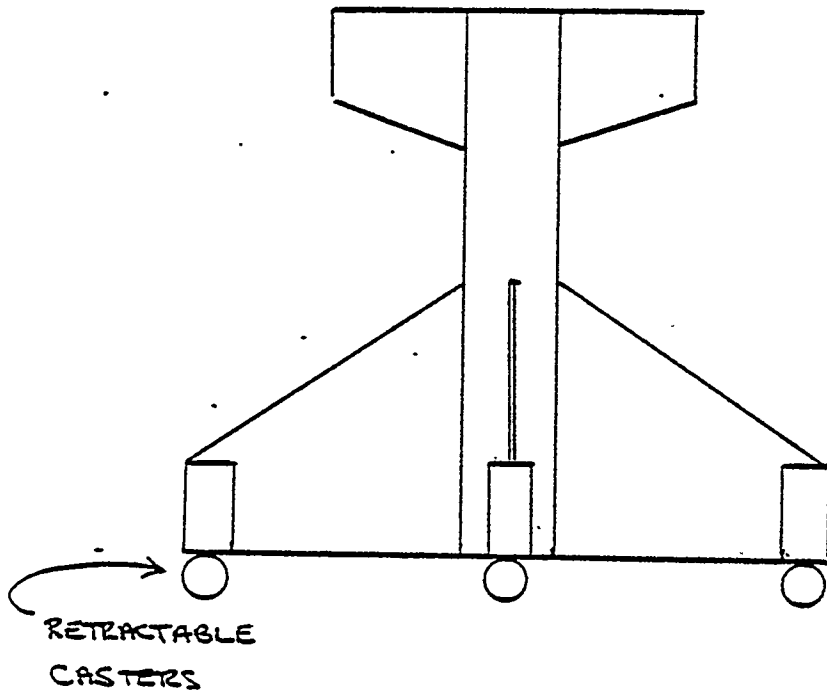

EXHIBIT - 5