

Design Modeling

U.S. DEPARTMENT OF TRANSPORTATION

Maritime Administration

in cooperation with

Todd Pacific Shipyards Corporation

Report Documentation Page

Form Approved
OMB No. 0704-0188

Public reporting burden for the collection of information is estimated to average 1 hour per response, including the time for reviewing instructions, searching existing data sources, gathering and maintaining the data needed, and completing and reviewing the collection of information. Send comments regarding this burden estimate or any other aspect of this collection of information, including suggestions for reducing this burden, to Washington Headquarters Services, Directorate for Information Operations and Reports, 1215 Jefferson Davis Highway, Suite 1204, Arlington VA 22202-4302. Respondents should be aware that notwithstanding any other provision of law, no person shall be subject to a penalty for failing to comply with a collection of information if it does not display a currently valid OMB control number.

| | | | | | |
|--|------------------------------------|-------------------------------------|---|---|------------------------------------|
| 1. REPORT DATE JUL 1984 | | 2. REPORT TYPE N/A | | 3. DATES COVERED - | |
| 4. TITLE AND SUBTITLE Design Modeling | | | | 5a. CONTRACT NUMBER | |
| | | | | 5b. GRANT NUMBER | |
| | | | | 5c. PROGRAM ELEMENT NUMBER | |
| 6. AUTHOR(S) | | | | 5d. PROJECT NUMBER | |
| | | | | 5e. TASK NUMBER | |
| | | | | 5f. WORK UNIT NUMBER | |
| 7. PERFORMING ORGANIZATION NAME(S) AND ADDRESS(ES) Naval Surface Warfare Center CD Code 2230-Design Integration Tower Bldg 192, Room 128 9500 MacArthur Blvd Bethesda, MD 20817-5000 | | | | 8. PERFORMING ORGANIZATION REPORT NUMBER | |
| 9. SPONSORING/MONITORING AGENCY NAME(S) AND ADDRESS(ES) | | | | 10. SPONSOR/MONITOR'S ACRONYM(S) | |
| | | | | 11. SPONSOR/MONITOR'S REPORT NUMBER(S) | |
| 12. DISTRIBUTION/AVAILABILITY STATEMENT Approved for public release, distribution unlimited | | | | | |
| 13. SUPPLEMENTARY NOTES | | | | | |
| 14. ABSTRACT | | | | | |
| 15. SUBJECT TERMS | | | | | |
| 16. SECURITY CLASSIFICATION OF: | | | 17. LIMITATION OF ABSTRACT SAR | 18. NUMBER OF PAGES 119 | 19a. NAME OF RESPONSIBLE PERSON |
| a. REPORT unclassified | b. ABSTRACT unclassified | c. THIS PAGE unclassified | | | |

FOREWORD

The U.S. shipbuilding industry is well into a revolution. Surprisingly, it is not due to the use of computers, numerical-control machines or robots. Instead, the revolution is motivated by a renewal of human logic, i.e., a shift from system to zone orientation in the minds of people.

Such reorientation enables a building strategy to be planned and applied before contract design begins. As a design develops, a building strategy is repeatedly refined in phases so as to guide remaining design efforts, i.e., functional, transition and work-instruction design. The process requires an unprecedented degree of interaction between production engineers and designers. As a consequence, even in shipyards having the most sophisticated computer-aided design systems, there has been a revival in the use of physical models to facilitate consultations and coordination between various design and production engineering teams.

Since the demand for physical models continues, this publication addresses their most effective use, i.e., for creative purposes during a crucial design phase. The first three chapters describe managerial aspects including the formation of design-modeling teams and estimated man-hours required. Thereafter, practical information is included for modeling and for presenting information so created in work instructions. Among the ideas described is a unique scheme for dividing a model into sections to permit more people to work simultaneously and so minimize overall time required for design.

ACKNOWLEDGEMENTS

This publication was produced for the Los Angeles Division of Todd Pacific Shipyards Corporation by L.D. Chirillo Associates of Bellevue, Washington.

The material on which the contents are based was compiled by a project team directed by K. Nabeshima and advised by Y. Tornita, both of the Technology and Development Headquarters, Hitachi Zosen Corporation of Japan. H. Hata and H. Shimizu also served as advisors. The project team was led by T. Nishio. Team members were R. Iwamoto and M. Eya. Their work was edited and supplemented by L.D. Chirillo assisted by J.F. Curtis of Manufactured Systems, Inc., Bellevue, Washington.

Appreciation is expressed to T. Lamoureux, L. Willets, D. Jones and B. Coralles of Todd's Los Angeles Division, who furnished essential support.

This publication is an end product of one of the many projects managed and cost shared by Todd for the National Shipbuilding Research Program. The Program is a cooperative effort by the Maritime Administration's Office of Advanced Ship Development and the U.S. shipbuilding industry. The objective, described by Panel SP-2 of the Ship Production Committee of the Society of Naval Architects and Marine Engineers, is to improve productivity.

TABLE OF CONTENTS

1.0 Introduction 1

2.0 Pertinent Factors 3

 2.1 What Design Modeling Achieves 3

 2.2 Benefits 3

 2.3 Present Utilization 4

 2.3.1 Check Models 4

 2.3.2 Design Models 4

 2.4 Notes for Application of Design Modeling Techniques 5

 2.4.1 Main Purpose 5

 2.4.2 Changes 5

 2.4.3 Range of Modeling 5

 2.4.4 Consultation and Coordination 5

 2.4.5 Technical Data 5

3.0 Planning and Scheduling Design Modeling 7

 3.1 General 7

 3.2 Shipbuilding and Design Modeling Schedules 7

 3.2.1 General 7

 3.2.2 Typical Shipbuilding and Design Modeling Schedules 7

 3.2.3 Short-Term Schedules 11

 3.3 The Process of Design Modeling 12

 3.3.1 Relative to Engine-Room Design Work Flow 12

 3.3.2 The Overall Process 12

 3.4 Team Formation 18

 3.5 Basic Planning for Design Modeling 18

 3.5.1 Ideal Scales for Sizing 18

 3.5.2 Sectioning 18

 3.5.3 Range of Modeling 18

 3.5.4 Required Information 23

 3.5.5 Selection and Control of Materials 23

 3.5.6 Detail Work Schedule 23

 3.5.7 Design Modifications During Modeling 23

 3.5.8 Man-Hour Estimates 23

 3.6 Rough Layouts 24

 3.6.1 General 24

 3.6.2 Information Required in Advance 24

 3.6.3 Auxiliary Machinery Foundations 26

 3.6.4 Ventilation Ducts 29

 3.6.5 Walkways, Gratings and Ladders 29

 3.6.6 Tanks 29

 3.6.7 Cableways and Trays 29

 3.6.8 Piping 29

TABLE OF CONTENTS (Continued)

4.0 Hull Modeling 41

 4.1 Materials and Colors 41

 4.2 Sectioning43

 4.3 Dimensioning and Accuracy 43

 4.3.1 Dimensioning 43

 4.3.2 Tolerances 43

 4.3.3 Reference Lines 43

 4.4 Model Assembly Drawings.....43

 4.5 Construction47

 4.5.1 Model Bases and Tank Tops 47

 4.5.2 Shell Plating..... 47

 4.5.3 Frames 47

 4.5.4 Girders, Beams and Sea Chests 47

 4.5.5 Decks47

 4.5.6 Engine Casing 49

 4.5.7 Brackets 49

 4.6 Web Frame and Column Fabrication and Assembly49

 4.7 Connecting and Fastening Model Hull Sections58

 4.8 Adhesives58

 4.9 Miscellaneous Items60

5.0 Modeling Machinery61

 5.1 General61

 5.2 Machinery Items 61

 5.3 Materials and Colors61

 5.3.1 Materials61

 5.3.2 Strength 61

 5.3.3 Colors 62

 5.4 Accuracy62

 5.5 How to Model Machinery62

 5.5.1 Shape 62

 5.5.2 Cylinders, Cones and Cubes.....63

 5.5.3 Machinery Models 63

 5.5.4 Other Matters 63

TABLE OF CONTENTS (Continued)

| | |
|--|-----|
| 6.0 Model Fittings | 73 |
| 6.1 Piping | 73 |
| 6.2 Ventilation Ducts | 73 |
| 6.3 Steel Work | 73 |
| 6.3.1 Tanks | 73 |
| 6.3.2 Foundations | 73 |
| 6.3.3 Walkways and Gratings | 74 |
| 6.3.4 Ladders | 74 |
| 6.3.5 Stanchions and Handrails | 74 |
| 6.3.6 Lifting Beams | 74 |
| 6.3.7 Storeroom Racks | 74 |
| 6.3.8 Exhaust Pipes | 74 |
| 6.3.9 Pipe Bands | 74 |
| 7.0 Piping Work | 85 |
| 7.1 General | 85 |
| 7.2 Outfitting On-Unit | 85 |
| 7.3 Outfitting On-Block | 85 |
| 7.4 Outfitting On-Board | 85 |
| 7.5 Electrical Equipment | 88 |
| 8.0 Work Instructions Derived From Models | 89 |
| 8.1 Assembly Drawings | 89 |
| 8.1.1 Drawings for Outfitting On-Unit. | 89 |
| 8.1.2 Drawings for Outfitting On-Block | 89 |
| 8.1.3 Drawings for Outfitting On-Board | 89 |
| 8.1.4 Other Assembly Drawings | 89 |
| 8.2 Fabrication Drawings | 89 |
| 8.2.1 Pipe Pieces | 89 |
| 8.2.2 Auxiliary Machinery Foundations | 96 |
| 8.2.3 Walkways and Ladders | 96 |
| 8.2.4 Tanks | 102 |
| 8.2.5 Ventilation Ducts | 102 |
| 9.0 Model Shop Facilities and Requirements | 105 |
| 9.1 Location and Space | 105 |
| 9.2 Conditions for Modeling Work. | 105 |
| 9.2.1 Environment | 105 |
| 9.2.2 Furniture, Equipment and Tools | 105 |
| 10.0 Design Modeling for Other Than Ships | 109 |



EX SCIENTIA EFFICIENS

1.0 INTRODUCTION

Shipbuilders throughout the world have difficulty in retaining people experienced enough to create complex machinery arrangements and simultaneously incorporate building strategies for integrated hull construction, outfitting and painting into designs. In the Third World, cheap-labor shipbuilding industries are becoming more effective in high-volume standardized production. This forces shipyards in expensive-labor countries to address flexible manufacturing and construction systems. Such systems feature production-oriented work breakdowns and statistical control of production. The resulting methods, developed to build ships, are also applied for effective construction of diverse products such as chemical and waste-treatment plants in any quantity, particularly one of a kind. Thus, any tools which facilitate integration of design and production-engineering for a wide variety of end products are of great interest.¹

Computer-aided design (CAD) has developed remarkably in recent years. The most advanced employ hidden-line and shading techniques so that a computer-generated "three-dimensional" picture is presented as if it were of a physical model. Where CAD capabilities exist they have to some extent replaced need for physical models. However, there are inherent limitations. Complex three-dimensional arrangements cannot be readily perceived on a two-dimensional surface of a cathode-ray tube. Also, screen sizes limit teams of designer-planners from viewing and discussing all aspects of a complex arrangement simultaneously. For complicated arrangements, the need for physical models persists.

The need is amplified by the revolution in shipbuilding methods which began in the U.S. shipbuilding industry in 1979. Simply described, the revolution features a shift in logic, i.e., from system to zone orientation for most design and production-engineering efforts. Composite arrangements are produced directly from diagrammatics so as to eliminate expensive and time-consuming system arrangement and detail (A&D) drawings. Most important, a strategy for on-unit, on-block and on-board outfitting is incorporated so that there is no need for a separate planning effort to define work pack-

ages after completion of detail design.^{2,3} Such design production-engineering integration has contributed to a resurgence in the use of physical models.

Some shipbuilders, even among those who have perfected computer-applied interactive graphics, found it more productive to create complex machinery and piping arrangements using design modeling for the creative phase and thereafter, computers for refinements and changes. Also, because durations between contract awards and deliveries became singular elements of competition, and existing files of standard components and modules were adequate for current orders, one shipbuilder having both CAD and physical modeling capabilities, returned to pencil and paper for the purpose of improving both design productivity and speed. In other words, market circumstances sometimes dictate the most effective design method.

Some owners require physical models for reasons of their own. As such models are usually composites which can fulfill all design needs for interrelating systems and zones, spending time and money to produce the same arrangement in another medium just doesn't make sense. Further, traditionalists who employ physical models just to locate and resolve interferences between archaic system A&Ds, are unable to maintain the same conjuration in both mediums to any satisfactory degree. A model for an owner's requirement, can readily serve as the composite for design.

Design modeling, i.e., the cutting, forming and/or joining pieces of plastic as a medium for creating a physical model of an arrangement, is not a panacea that can be generally applied. Conceivably, three different methods could be simultaneously employed for effectively creating arrangements in different regions of one ship, e.g., traditional drafting for simple parallel pipe-runs, design modeling for very complex arrangements, and computer-applied interactive graphics elsewhere. In all cases, computers are the most effective for incorporating repetitive design details, defining material requirements, maintaining structured material lists, entering changes, etc.

¹L.D. Chirillo, R.D. Chirillo, "Flexible Manufacturing - What it Means in Shipbuilding," Pacific Northwest Section, The Society of Naval Architects and Marine Engineers, 25 February 1984.

²Aspects of the revolution are described in the National Shipbuilding Research Program (NSRP) publications "Integrated Hull Construction, Outfitting and Painting - May 1983" and "Design for Zone Outfitting - September 1983." All NSRP publications referenced herein are available to U.S. shipbuilders in limited quantities from: L.D. Chirillo Associates, P.O. Box 953, Bellevue, WA 98009.

³The word unit is used to designate an assembly of just outfit materials. Thus, on-unit outfitting does not involve any hull structure.

One shipbuilder bridged the gap between a model and computer by digitizing from prints of models obtained by orthophotography. A design firm developed a similar technique using laser scanning to also produce orthographic prints. In both systems, two-dimensional digitizing is performed on the prints and extreme care is taken to coordinate collection of data for a third dimension at a computer input terminal. A photogrammetric system has been described which can digitize in three dimensions for direct input into a computer with less chance for human error. Obviously, it is now feasible to use design modeling for creative work while taking advantage of a computer to more quickly and more accurately perform such routine chores as pipe-piece detailing, reproducing standard details and preparing material lists. However, highly sectioned design models are required in order to provide sufficient visual access as for a camera.⁴ Also, more knowledge is required about how the act of modeling is a design technique, i.e., about design modeling.

Chapter 2.0 addresses the usefulness, present state, etc. of design modeling applied to a ship's engine-room. Chapter 3.0 describes:

- **how design modeling for construction of a ship's engine-room is included in the overall shipbuilding schedule,**
- **a process for design modeling by stages, i.e., preparation, planning, model making, etc.,**
- **team formation, and**
- **rough layout drawings prerequisite for modeling, together with related data, plans, work schedules, etc.**

Chapters 4.0, 5.0 and 6.0 contain useful information about how to model a hull and how to model outfit components. Modeling assemblies to reflect how outfitting is to be actually implemented on-unit, on-block and on-board, is described in Chapters 7.0 and 8.0 along with examples of work instructions derived from models. Model shop facilities and requirements are described in Chapter 9.0. With Chapter 10.0, which addresses end products other than ships, this publication should aid shipbuilders in meeting requirements of flexible-system production.

⁴ Description of the photogrammetric method and some information about other methods, are contained in the NSRP publication "Photogrammetric Dimensioning of Ships' Engine-room Models - March 1981."

2.0 PERTINENT FACTORS

2.1 *What Design Modeling Achieves*

A typical design model for a ship's engine-room faithfully incorporates the constraints imposed by the hull structure at a certain reduced scale and within certain accuracy tolerances. Employing roughly arranged diagrammatic, supplemented at first by more detailed sketches, designers create an engine-room arrangement in a prescribed zone sequence using a model as a common medium for examination, communication and checking. Usually, as construction and use of a design model becomes more routine, designers employ fewer sketches and create more aspects of the design directly with model components.

A typical engine-room consists of just the enveloping portion of a hull, a main engine, auxiliary machinery, piping, ventilation ducts, electric-cable trays, electric panels, motor controllers, switchboards, independent tanks, walkways, gratings, ladders, etc. At first the constraining portions of the hull, machinery and various fittings are individually modeled based on hull key-plans and vendors' preliminary drawings. Next they are assembled as an engine-room model per a machinery arrangement and with connecting systems, such as piping and walkways, in accordance with rough layouts, i.e., *composite drafts*. At this stage, only details which impact on ship-operating aspects and shipbuilding strategy are defined. Such details include locations of:

- controls, valves and gages related to a pump,
- fittings relative to hull erection-butts and seams, and
- only the pipe joints needed for ship maintenance and for distinguishing outfit work for assembly on-unit, on-block and on-board.

Thus, preparation of rough layouts must be entrusted to the most experienced individuals having command of both ship-operating and shipbuilding methods. What they achieve is the first stage of transition design, i.e., the first interrelation of systems and zones. Information which had so far been organized by systems is regrouped so as to become organized by zones.

Design modeling is the second stage of transition design as *a model is a three-dimensional composite* which portrays exact locations and identities.¹

Design modeling replaces traditional drafting in the second stage of transition design only. Data needed to prepare work instructions are extracted from the model by manual, electro-mechanical or photographic methods². Work-instruction design, includes piece-by-piece definition of all fittings not previously detailed, e.g., exact definition of pipe pieces, supports and penetrations.

2.2 *Benefits*

As a consequence of progress, specifications for machinery spaces require more complexity and better quality. In addition, the realities of competition require that a building strategy be incorporated in the design process even as early as contract design. In other words, design now requires a tremendous amount of mental energy and discipline to avoid making uncountable trial-and-error attempts in a two-dimensional medium in search of an ideal three-dimensional arrangement.

Further, checking can never be truly effective with two-dimensional mediums. Checkers are expensive because the best of them are frequently the most experienced designers. Secondly, the vast amount of detail on a typical machinery drawing makes it virtually impossible for a designer and checker to both become 100% familiar with all of the philosophy and details of a design. The quality of the arrangement so produced, particularly regarding the existence of interferences, depends primarily on individual designers involved despite the fact that undetected errors can have considerable adverse impact on production work.

Design modeling, in contrast, introduces a three-dimensional rendition at a crucial phase of the overall design process. Faithful representation of an arrangement as a three-dimensional physical model enables numerous designer participants and their supervisors to frequently, easily and simultaneously check each person's contribution and progress relative to the others'. Thus, design models for complex arrangements enhance rationalization of the design process and improve design quality. The obvious consequence, is improved productivity in outfitting shops.

¹The design functions and the terms used are the same as in Chapter 4.0 of the NSRP publication "Design for Zone Outfitting - September 1983."

²See Appendix B of the NSRP publication "Photogrammetric Dimensioning of Ships' Engine-room Models - March 1981."

The usefulness of design modeling is summarized as follows:

- an arrangement existing in three dimensions facilitates group thinking and checking so as to minimize errors in design and rework in production,
- fewer outfitting designers are required as some amount of design modeling can be performed by people having only experience in an outfit shop,
- build-strategy communications between field engineers assigned to shops and designers are enhanced,
- communications with owners concerning their requirements for maintenance, inspection, overhaul, handling of stores, etc., are enhanced and become more timely (owners' requirements for changes when fabrication and assembly work is in progress are minimized),
- similarly, communications with regulators are enhanced (e.g., the effectiveness of a bilge suction is sometime difficult to perceive in a two-dimensional representation, whereas in a model the effect of a bilge suction relative to its surroundings is very easy to assess),
- a design model is an effective media for educating young people in ship design, planning and production control, and
- a design model is a data bank, permitting rapid search and retrieval, useful for maintaining configuration control, such as for construction of near-identical ships in series, and for discussion of machinery-space features with a prospective customer.

2.3 Present Utilization

Machinery-space models which are employed in both shipyards and independent design firms are primarily used either for checking or designing.

2.3.1 Check Models

Traditional check models are employed when design phases following preparation of system diagrammatic, remain system oriented. In this archaic approach, individuals or separate teams are each assigned responsibility for a separate system A&D drawing. Usually, priorities are assigned for design sequencing based on installation difficulty and/or system performance.

Designers with low-priority systems have to work around previously designed systems so that expensive pipe pieces having numerous and odd-angle bends are required.³ Moreover, the preparation of system A&D drawings, because of conditions inherent in the process, is so time consuming and expensive that traditional shipbuilders usually "field run" pipe that is less than 2-inches in diameter. In other words, they are so preoccupied with attempts to find and resolve interferences caused by the more-or-less independent preparation of system arrangements, that they defer virtually all planning and production-control responsibilities for pipe systems under 2-inches in diameter to the pipe fabrication and assembly people. In some ships, pipe under 2-inches in diameter exceeds 50% of the total length of all pipe installed.

Instead of employing a model as the design medium and applying zone-oriented logic to prevent the above condition, traditionalists employ models built after-the-fact in order to *check* for interferences. Frequently, resolution of an interference requires modification to both a system A&D drawing and the model used for checking. Often, needed model modifications are ignored causing adverse effects on configuration control, i.e., the drawings and the check model differ enough so that the check model becomes useless. In one instance involving design of a very compact high-powered engine room, configuration control became so disrupted and the inadequacy of the separately derived system A&D drawings became so manifest, that designers were forced midway in the project to employ the check model as a design model.

2.3.2 Design Models

Design models, particularly where zone orientation is practiced, enable a design group to better perceive the impact of a developing design on productivity in production organizations. Difficulties in fabricating and assembling model pipe-pieces having numerous bends at odd angles, foretell difficulties that will be encountered by pipe-piece fabricators and assembly workers in production. Pipe runs that are unnecessarily not parallel to other runs, so that they cannot be assembled on common supports or share a common bulkhead penetration fitting, are immediately apparent.

As the transition-design process is being executed in only one medium, resources are more likely to be available for including runs as small as 1/2-inch diameter and even smaller diameter tubing either in a model or on subsequently prepared work instructions. Most important, a strategy for building a design model is usually devised to be the same or nearly the same as that specified by production engineers for building an actual machinery space. That is, division of assemblies within a model reflects on-unit, on-block and on-board outfitting.

³The need to eliminate odd-angle bends is far more significant than is generally realized. Statistical control of manufacturing, as described for hull construction in the NSRP publication "Process Analysis Via Accuracy Control-February 1982," is a significant factor for effective pipe-piece fabrication and assembly in the world's most productive shipyards. Statistical discipline becomes impractical if there are many different odd-angle bends. Thus, the most productive shipyards standardize on 90- and 45-degree bends as much as possible.

2.4 Notes for Application of Design Modeling Techniques

2.4.1 Main Purpose

Before requirements for tolerances, material composition, finish, etc., are specified, the main purpose of any model must be described. In the case of design modeling, relatively great accuracy and precise tolerances are important but are employed with discretion. That is, such requirements are limited only to parts and regions where necessary. Human tendency to achieve a display of good workmanship in models is subdued in favor of *sufficient workmanship*.

2.4.2 Changes

Significant thought must be given to the probable impact of design modifications which can be caused by owners (typically 50%), other design groups (25%) and others in general (25%). However, because of the complexity of the kinds of end products that flexible-system manufacturing infers, changes are inevitable. Their numbers can be reduced and their impacts minimized by specifically organized preparations and countermeasures that are addressed elsewhere.⁴

2.4.3 Range of Modeling

What is to be incorporated in a design model has to be decided beforehand based on discussion led by a design coordinator which includes contributions from various concerned parties, e.g., design groups which have interface responsibilities, production engineers, owner representatives, and regulators.

2.4.4 Consultation and Coordination

Consultation and coordination between various design groups and production engineers are essential throughout a design modeling process. A coordinator establishes procedures, including regularly scheduled meetings, beforehand.

2.4.5 Technical Data

Technical data and other relevant information are apt to cause delay as with any other design process. Thus, design modeling should start when a sufficient amount of key plans (diagrammatics) are completed rather than wait for the end of functional design. Much emphasis must be placed on communication with vendors and obtaining their preliminary and final drawings for machinery items and fittings.

⁴See Chapter 6.0 of the NSRP publication "Design for Zone Outfitting - September 1983."

3.0 PLANNING AND SCHEDULING DESIGN MODELING

3.1 General

Just as planning and scheduling efforts are prerequisites for construction of a ship, planning and scheduling efforts are also required for constructing a design model. As for any other project, a design-modeling schedule is dependent upon a master schedule for loading a shipyard. Thus, the major items addressed in planning and scheduling for a specific design model include:

- Ž shipbuilding schedules,
- Ž design-modeling process,
- Ž model scale and sectioning schemes,
- design-modeling team formation,
- selection and control of materials,
- Ž man-hour estimates,
- control of designer modifications, customer changes, etc. during the modeling process and notice of changes to concerned organizations,
- technical data and other information required for modeling,
- Ž technical data and other information to be derived from a model, and
- Ž rough layout sketches needed for modeling.

As a matter of vital importance, members of a design-modeling team should discuss, investigate and acquire knowledge of what they are going to deal with before deciding on a design-modeling schedule. In particular, for each project they must participate in devising, and have complete understanding of, the building strategy for which production engineers have primary responsibility.

3.2 Shipbuilding and Design Modeling Schedules

3.2.1 General

A simplified schedule of design and production stages required for outfitting an engine room is shown in Figure 3-1.

In order to derive a design-model schedule at least the following must be considered:

- scheduled completion of basic design and the contract award date,
- scheduled dates for keel laying and for starts of on-unit, on-block and on-board outfitting,
- scheduled dates for start fabrication of outfit components, and
- when and how data for work instructions will be extracted from the model.

In addition, some assessment should be made of the probable occurrence of changes due to an owner's requirements. Also, as a design for outfitting a ship's engine-room is closely related to designs for its hull, electric installation and various items of auxiliary machinery, a modeling schedule must be carefully coordinated with the schedule for the total design effort.

3.2.2 Typical Shipbuilding and Design-Modeling Schedules

An example of a typical schedule for building a ship of 30- to 50-thousand deadweight tons and of such outfit complexity that it requires about 15 months between contract award and delivery, is shown in Figure 3-2. A design-modeling schedule is incorporated for ready comparison. Such scheduling should conform with the following conditions:

- if outfitting on-unit is scheduled to start one month before keel laying (K-1) as shown, basic design should be completed at K-10 and the design model should be complete at K-5,
- Ž planning for the design model should start when there is a sufficient amount of functional design completed, usually about 30 days after functional design starts, and
- 4 to 4 1/2 months should be allocated for both planning and executing the design-modeling effort.

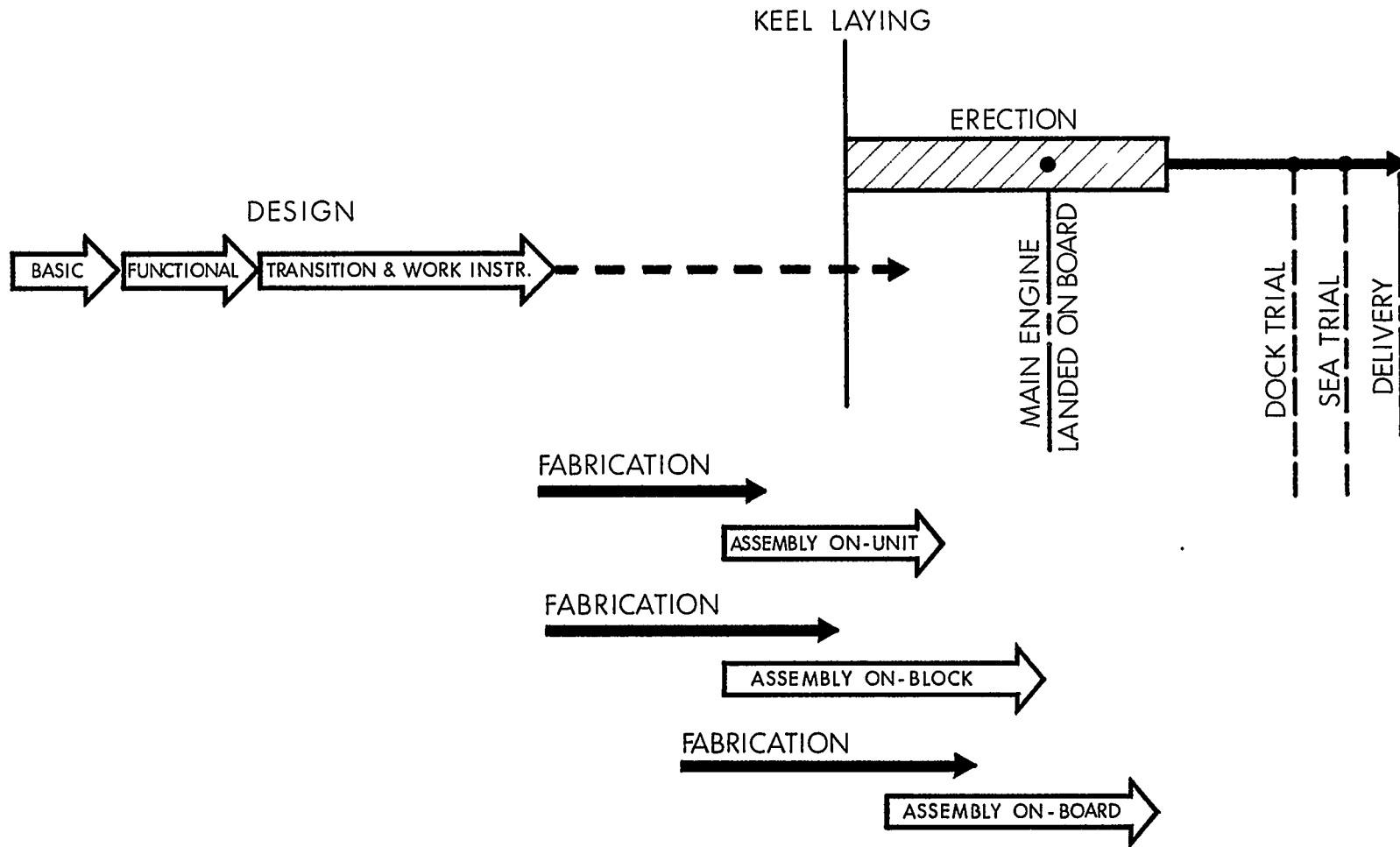

FIGURE 3-1: Simplified Schedule for Design and Production Stages Required for Outfitting an Engine-Room

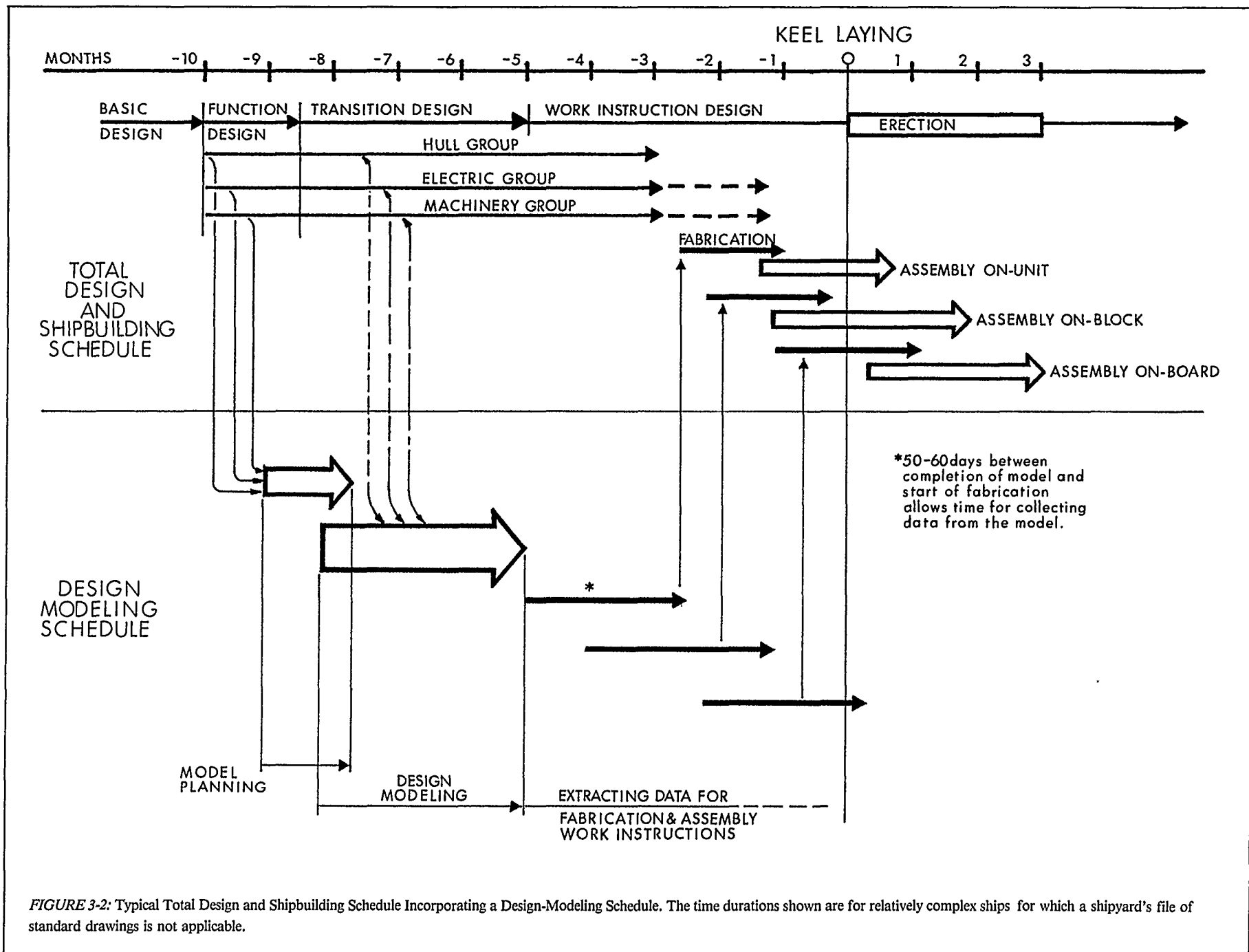

FIGURE 3-2: Typical Total Design and Shipbuilding Schedule Incorporating a Design-Modeling Schedule. The time durations shown are for relatively complex ships for which a shipyard's file of standard drawings is not applicable.

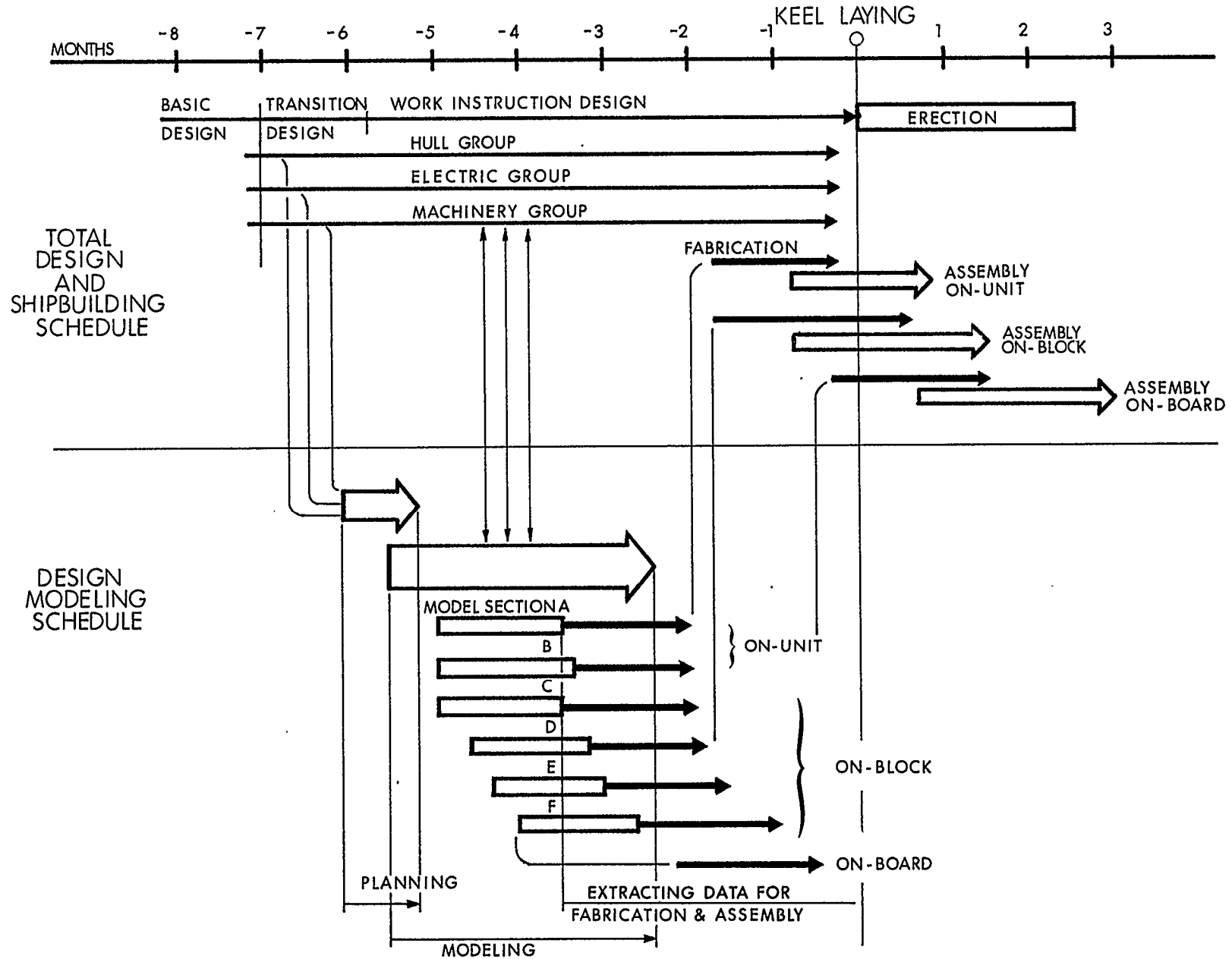

FIGURE 3-3: Typical Schedule for a Short-Term Building Period when the Owner Requires a Model. In the absence of such requirement, when the time between contract award and delivery is relatively short and when a shipyard's file of standards and modularized arrangements is sufficient, traditional design methods, i.e, paper and pencil assisted by a computer, are usually more effective than design modeling.

3.2.3 Short-Term Schedules

Sometimes, market circumstances are such that the ability to shorten the period between contract award and delivery to as little as 10-months duration is a singular element of competition. The start of functional design could be as late as K-6. Such conditions generally apply to building relatively simple ships for which standardization and modularization files can be used. Then, manual drafting supplemented by computer data-processing is usually the most effective means. While not probable, a requirement to employ a model is possible and design modeling is feasible if special efforts are applied.

A typical short-term building schedule is shown in Figure 3-3 which reflects the following conditions:

- a well-coordinated and elaborately-administrated production schedule for the purpose of shortening the durations allocated for outfitting on-unit and on-block and starting pipe-piece fabrication earlier,
- good communications between all departments, design groups and shops,
- increasing the number of model sections, as shown in Figure 3-4, in order to provide for more people working simultaneously and so reduce the durations needed for both design modeling and extraction of data.

Preferably, only one person should be assigned per model section. The positions and sizes of pipes and flanges at the model-section interfaces are important and must be decided in advance of modeling and clearly defined in the rough-layout sketches. Extraordinary supervision is required to insure that the design-modelers carefully honor such interface requirements.

Of equal importance to interface control is the control of bulkhead and deck penetrations. A design model serves as an exceptionally valuable tool in this regard. Decisions about the exact number and sizes of all penetrations should be made on the rough layouts before modeling starts. Such definition means that the locations and routings of all distributive systems are fixed relatively early in the design process. Single penetration fittings for multiple pipe systems are then detailed early enough to insure that they are fitted in hull blocks before erection; see Figure 3-5. The amount of rework associated with penetrations is inversely proportional to the degree of penetration control exercised during design.

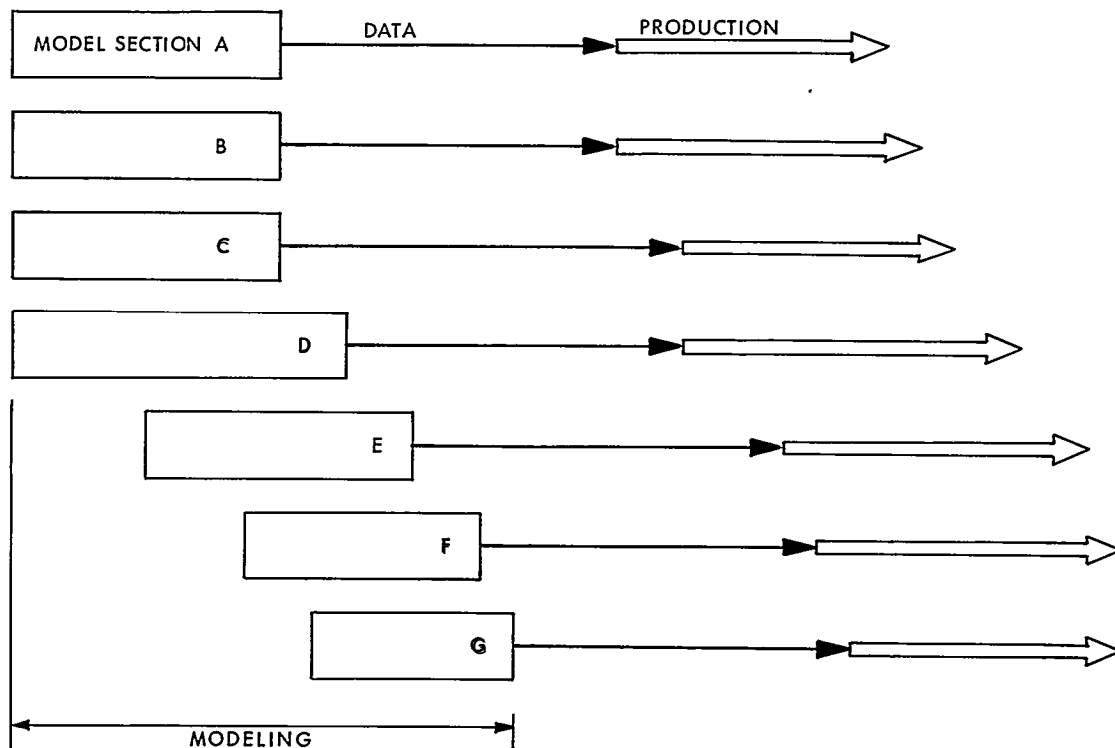

FIGURE 3-4: Modeling Work for a Short-Term Shipbuilding Schedule. Numerous model sections permit more people to simultaneously participate in both design modeling and extraction of data.

3.3 The Process of Design Modeling

3.3.1 Relative to Engine-Room Design Work Flow

The design modeling process as it appears in a design work flow for an engine room is shown in Figure 3-6. The work flow for design modeling compared to that for traditional design is contained in Figure 3-7. The traditional work flow depicted in the latter figure does not include a redundant composite-arrangement in the form of a model as frequently employed by traditionalists for checking purposes only.

With further reference to Figure 3-7, a design-modeling process simply consists of:

- Step 1- Preparing rough layout sketches (composite drafts) faithfully incorporating requirements in functional drawings (diagrammatic).*
- Step 2- Assembling a design model which incorporate a building strategy provided by production engineers.*

Design models are the equivalent of composite arrangements, or as sometimes called, synthetic arrangements.

- Step 3- Extracting data for manual or computer preparation of fabrication- and assembly-work instructions.*

3.3.2 The Overall Process

The overall design modeling process including the following steps is schematically shown in Figure 3-8:

- Step 1- Basic model planning and scheduling consisting of:*

- *team formation,*
- *deciding on the scale to be used for sizing the model,*
- *agreement on the model division scheme and range of modeling*
- *collection of technical data needed to make model components,*
- *establishment of a work schedule, and*
- *selection and procurement of materials needed to make the model.*

- Step 2- Planning and starting assembly of the hull portion of the model.*

- Step 3- Starting assembly of models of machinery components.*

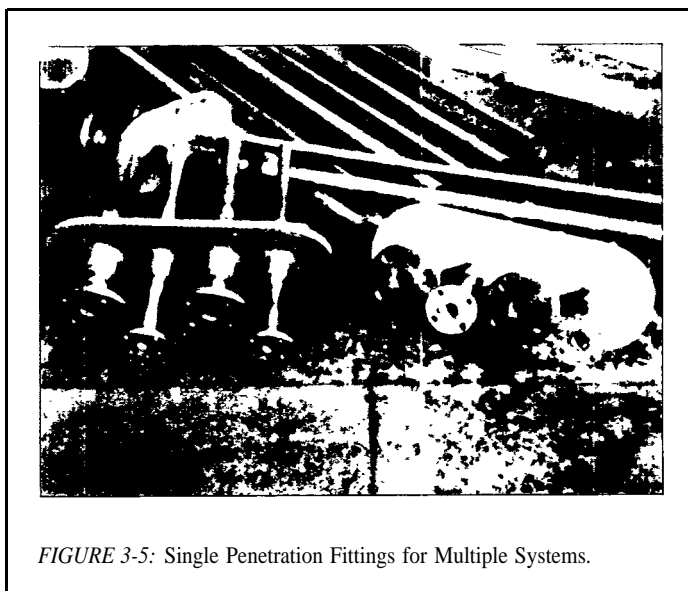

FIGURE 3-5: Single Penetration Fittings for Multiple Systems.

Simultaneously with the progress of Steps 2 and 3, preparing rough layout sketches for the following:

- Step 4- Piping runs.*
- Step 5- Auxiliary-machinery foundations*
- Step 6- Ventilation ducts.*
- Step 7- Tanks.*
- Step 8- Gratings, ladders and walkways.*
- Step 9- Electric cableways and trays.*

The rough layout sketches produced in response to Steps 3 through 9 are vital for coordinating the various design participants during their conception of arrangements and their implementation of design modeling.

- Step 10- Assembling models for fittings such as duct pieces, tanks, foundations, strainers, valves, etc.*
- Step 11- Temporarily arranging the modeled machinery and other components within the hull model, employing adhesive tape, for the purpose of obtaining owner and such other approvals that may be required.*

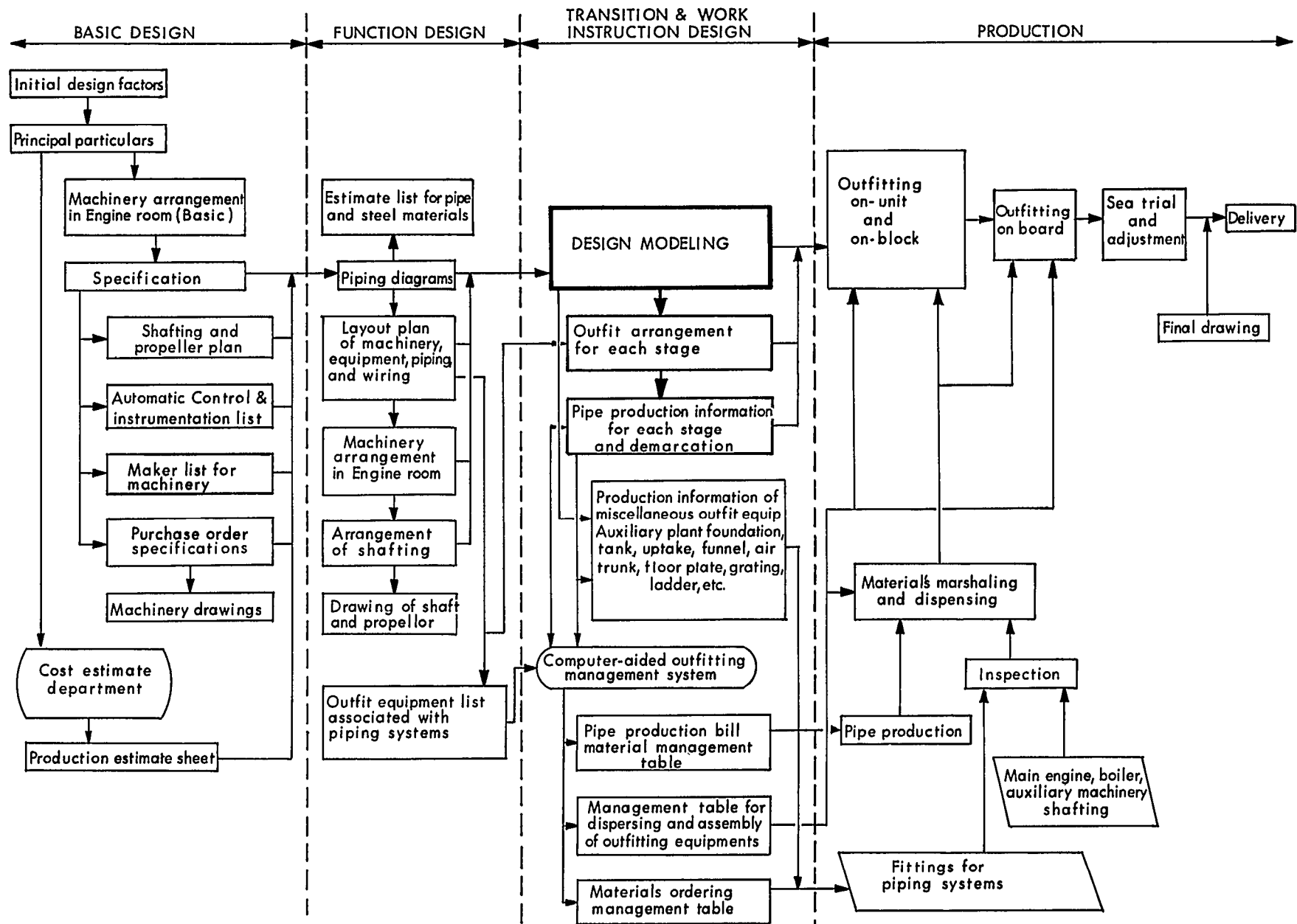

FIGURE 3-6: Outline Flow of a Design-Modeling Process for an Engine-Room.

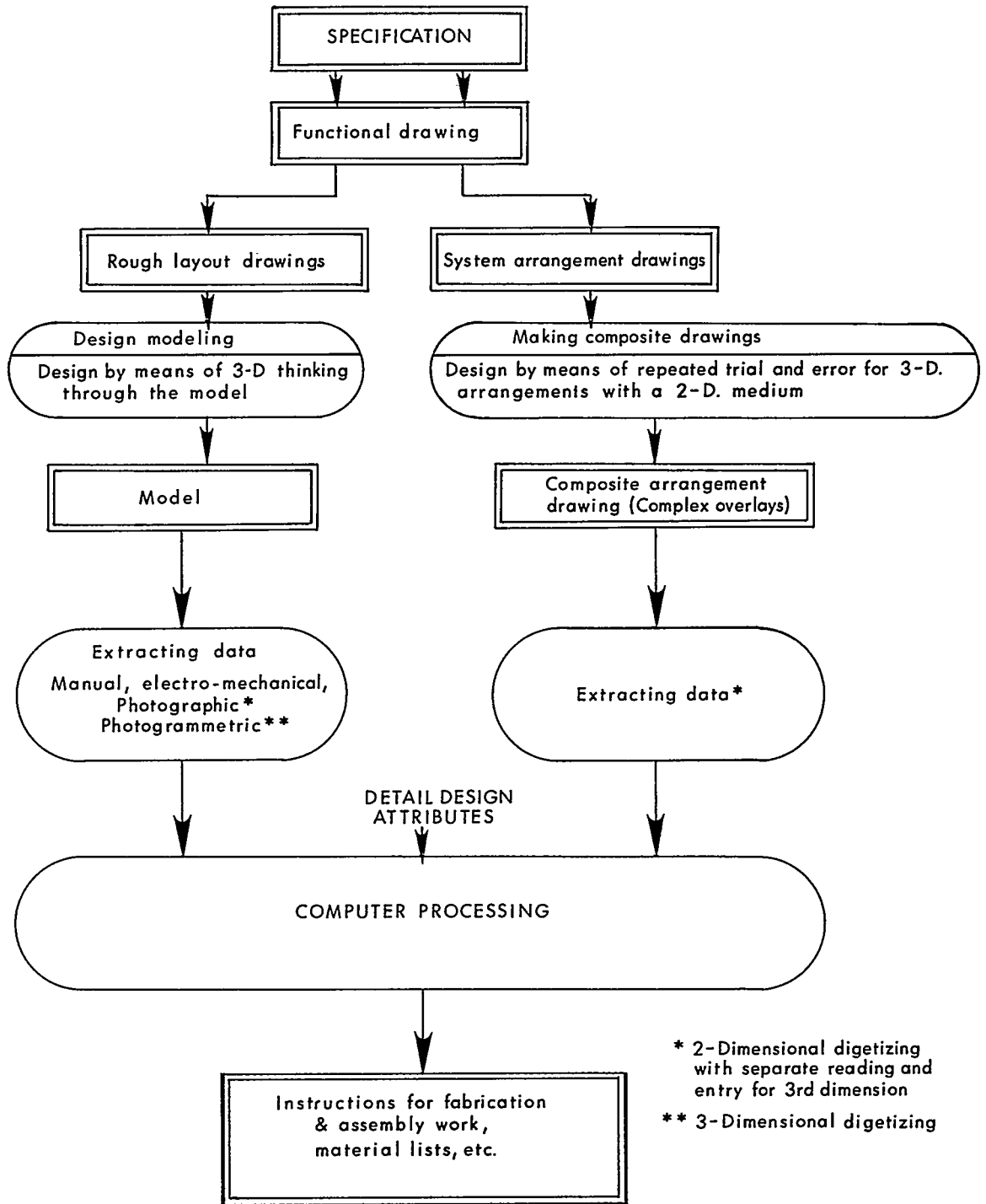
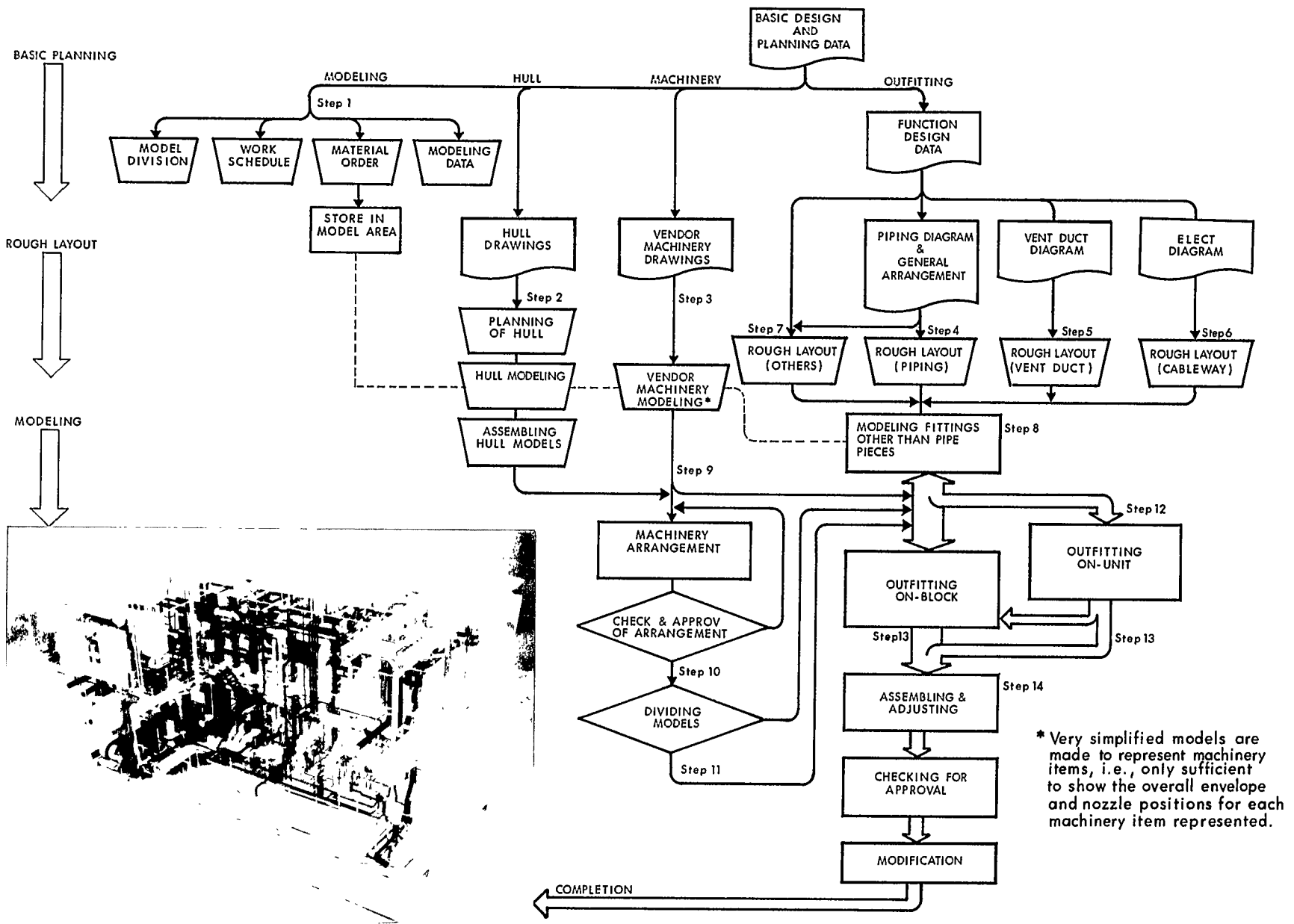

FIGURE 3-7: Comparison of Design-Modeling System and a Traditional-Design System for a Complex Arrangement.



Checking after Step 11 is of vital importance. An owner's intentions and demands concerning the engine-room machinery arrangement should be clearly reflected, confirmed and then documented with photographs. The need for such assurances cannot be understated because the owner's opinions as reflected by the contract drawings could change with design development or because of some other reason. Similarly, checks should be made to ensure that makers of machinery have not introduced changes by this time that would impact on the arrangement. Step 11 represents the last practical opportunity to incorporate some owner preferences and machinery-manufacturer changes without causing serious disruption to the remainder of the design effort and to the production effort.

Step 12- After receipt of owner's approval, dividing the temporary assembly in accordance with the model sectioning scheme.

Wherever possible, the divisions in the model should match those for outfitting on-unit and on-block in accordance with a specific building strategy. When large ships are built with large-capacity facilities, there are usually more separations required for modeling purposes than for actual ship construction. Sectioning also provides ideal camera access.

Step 13- Assembling the model sections permanently: see Figures 3-9, 3-10 and 3-11.

In such assemblies there is no need to reflect foundation details as they are not developed from modeling. Simple blocks with correct overall-dimensions are usually sufficient to represent foundations. Also, special care is taken to ensure that all required model sections are completed at nearly the same time.

Step 14- Joining the various model sections to create an entire engine-room model.

Step 15- Checking and adjusting as required between section interfaces until completion.



FIGURE 3-9: Design Model for On-Unit Outfitting.

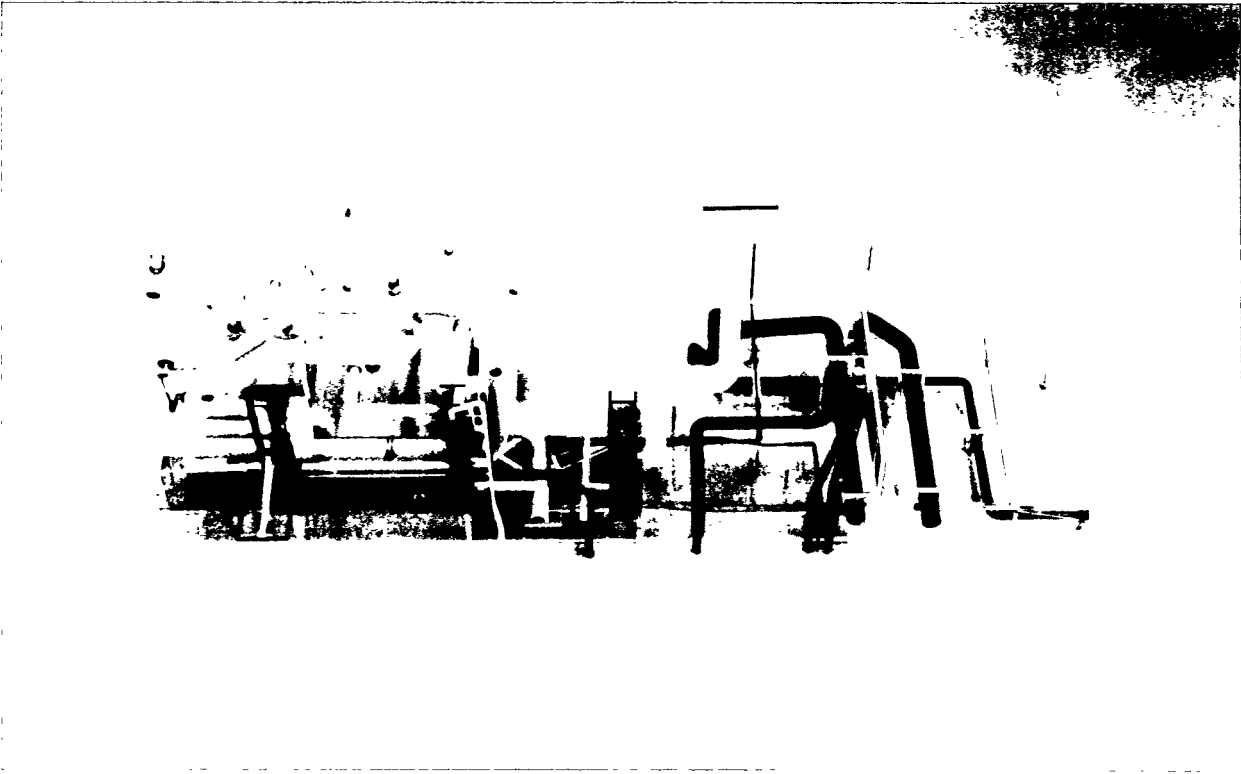

FIGURE 3-10: Design Model for On-Block Outfitting. An upside-down section of a ceiling is modeled down hand.

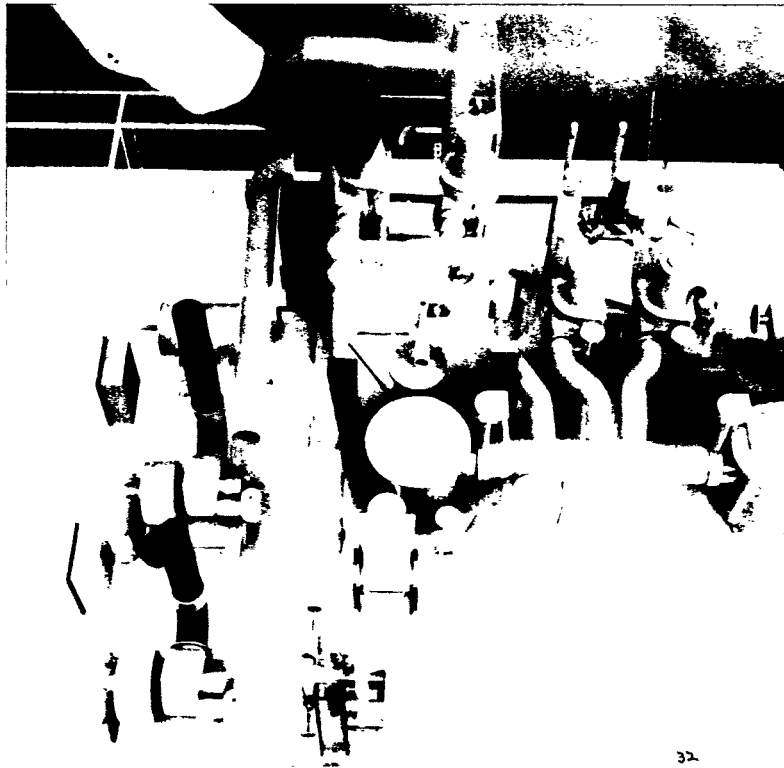

FIGURE 3-11: Design Model for On-Block Outfitting. Because the modeled deck is a two-part laminate, model outfitting on-deck as shown can proceed simultaneously with modeling on the ceiling below.

3.4 Team Formation

The team formation shown in Figure 3-12 is recommended because it identifies a distinct planning group. The group should consist of 2 or 3 designers each of whom has more than five years experience in mechanical design and is well informed about ship operation and maintenance as well as ship-building matters which impact on engine-room detail design. In addition to their planning responsibilities, one serves as the model coordinator while the remaining 1 or 2 participate in model assembly, routing pipe runs, etc.

Modeling of the hull, machinery items, and fittings, excluding standard model components that may be purchased, are made by modelers assigned for such work. Of the model makers so employed, 4 or 5 are retained to assist the designers during model assembly, routing pipe runs, etc.

3.5 Basic Planning for Design Modeling

3.5.1 Ideal Scales for Sizing

The scale to be used for design modeling is one of the most important planning subjects. The following must be considered:

- ease of calculation,
- ease of assembly work,
- ease of handling,
- accuracy,
- cost,
- purposes of model, etc.

Cost and ease of handling are directly related to model size; smaller models cost less. However, assembly work is easier to perform in large models; less skill is required. In general 1:15 scale is effective for ships of 10-thousand deadweight-tons or less, and 1:20 for larger ships. In exceptional designs when requirements for more detailed examination justify the higher cost, a scale of 1:10 is usually adopted.

3.5.2 Sectioning

Sectioning of a typical engine-room design-model necessarily takes into consideration hull form, modeling, assembling, handling, utilization of the completed model, etc. The following requirements are pertinent:

- in a relatively large section, model makers have difficulty in assembling parts that are located deep inside,
- each model section should facilitate visual and/or manual access commensurate with the method planned for extracting data,

- when the model sections are to serve as work instructions for on-block outfitting, the section divisions should coincide with planned erection butts and seams,
- even when the model sections are to serve as work instructions for on-block outfitting, if erection blocks are relatively small, 2 or 3 blocks should be combined into one model section,
- section dividing lines should provide for laminated decks and divisions between decks as shown in Figure 3-13 in order to facilitate on-block modeling of both decks and ceilings,
- section sizes must consider the strength characteristics of the material used for bases, e.g., for an acrylic-plastic sheet 3 to 5mm in thickness used as a base in a 1:15 scale model section, width and length should not exceed 600 and 800mm respectively, and
- in choosing the number of model sections, it is also necessary to consider the time scheduled for design modeling and the number of qualified people assigned to the design-modeling team.

Regarding the latter requirement, if a design model is required and the time between contract award and delivery is very short, the numbers of both model sections and people assigned to the modeling team must increase accordingly. A typical sectioning scheme for an engine room of a diesel-powered ship is illustrated in Figures 3-14(a) and (b).

3.5.3 Range of Modeling

What is to be modeled must be precisely defined during basic planning. Modeling everything is desirable but impractical. As an economic measure (cost and time) components which are not of vital importance to the process for creating an effective engine-room arrangement, are often omitted. The following parts and their equivalents should be omitted from the modeling process as they can readily be arranged in another design medium:

- the few pipes and fittings normally located around the top of the engine casing,
- pipe inside a double bottom,
- pipe within a funnel, and
- pipe and tubing of less than 1/2-inch diameter.

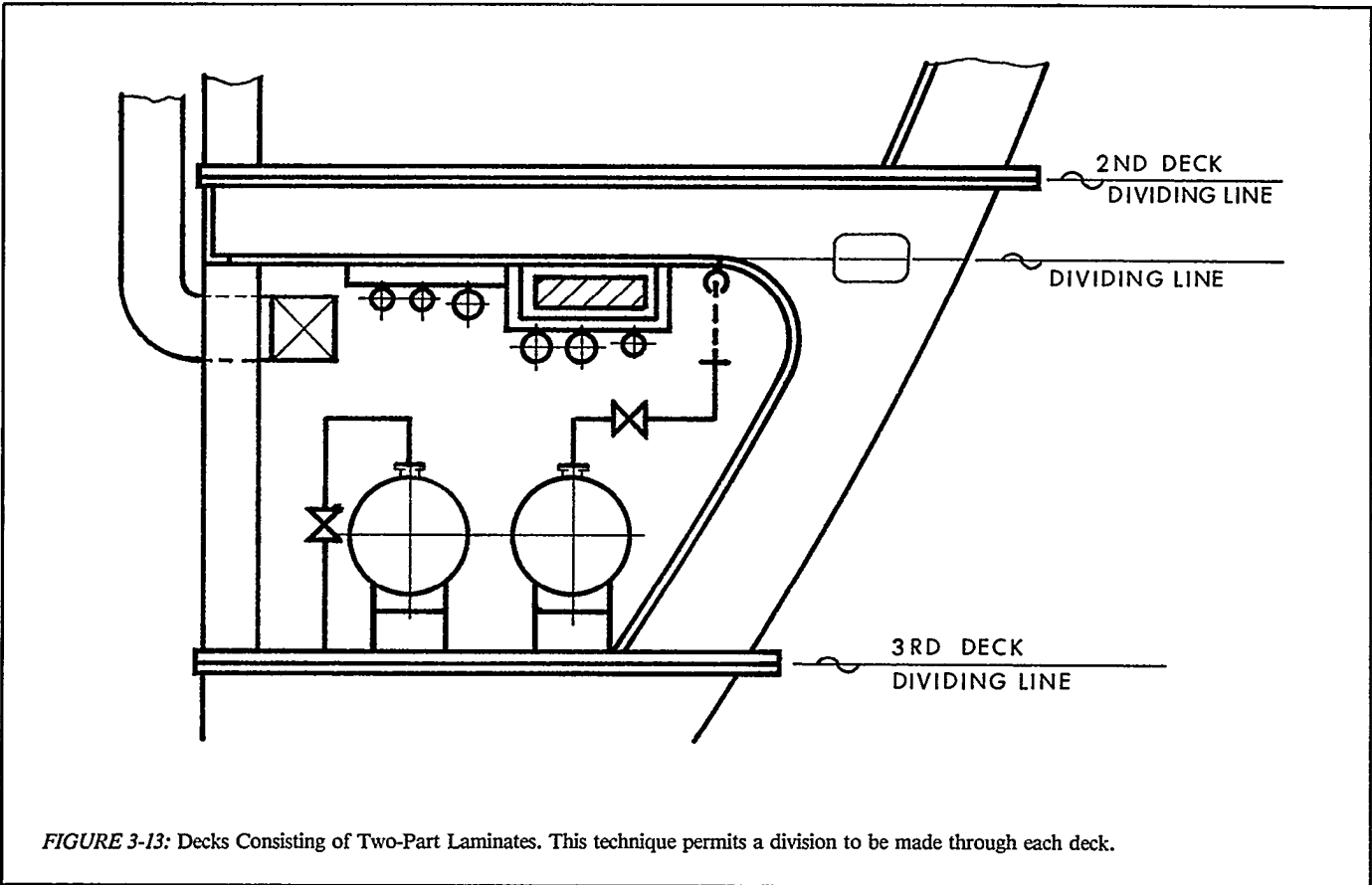
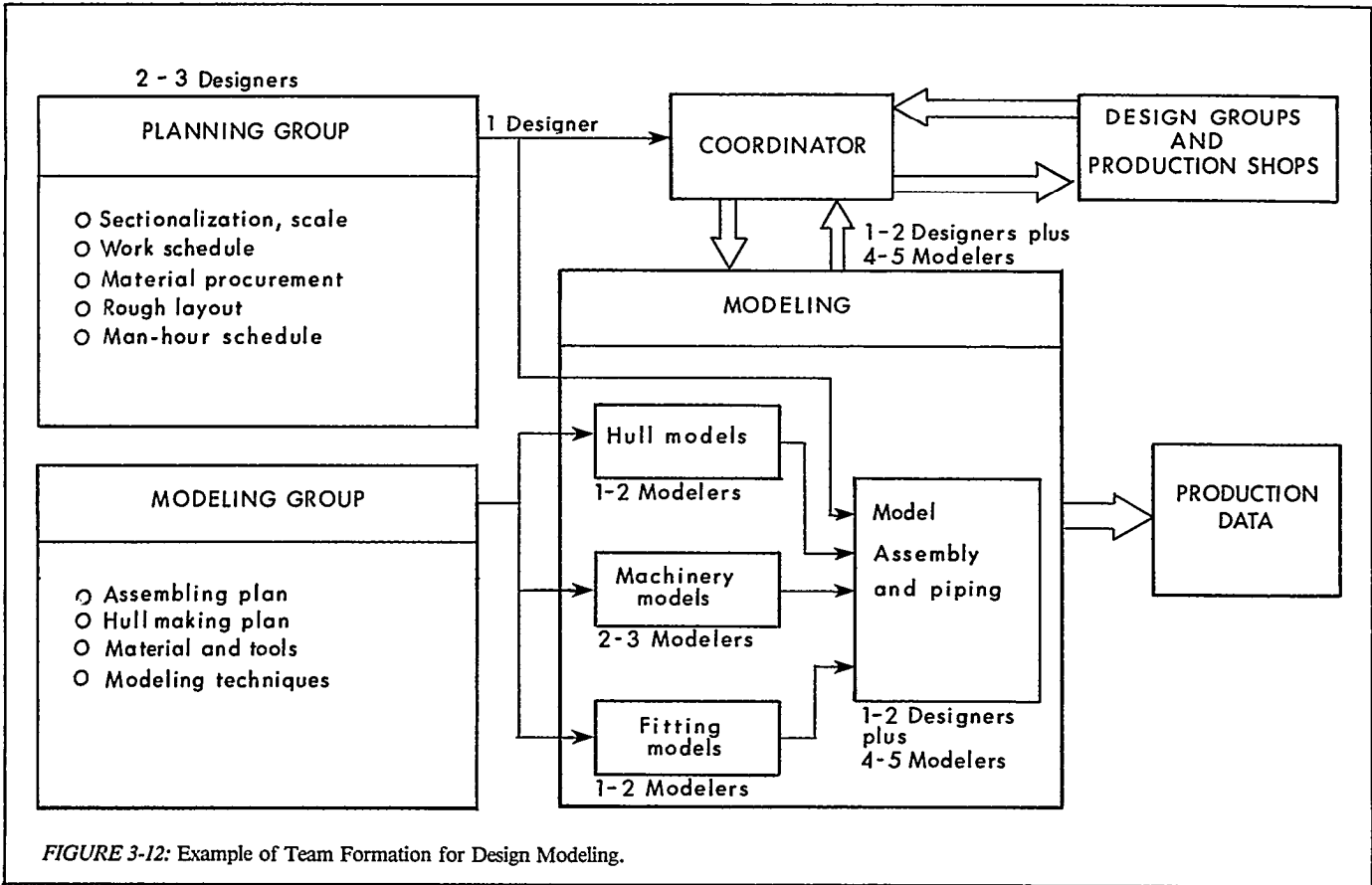

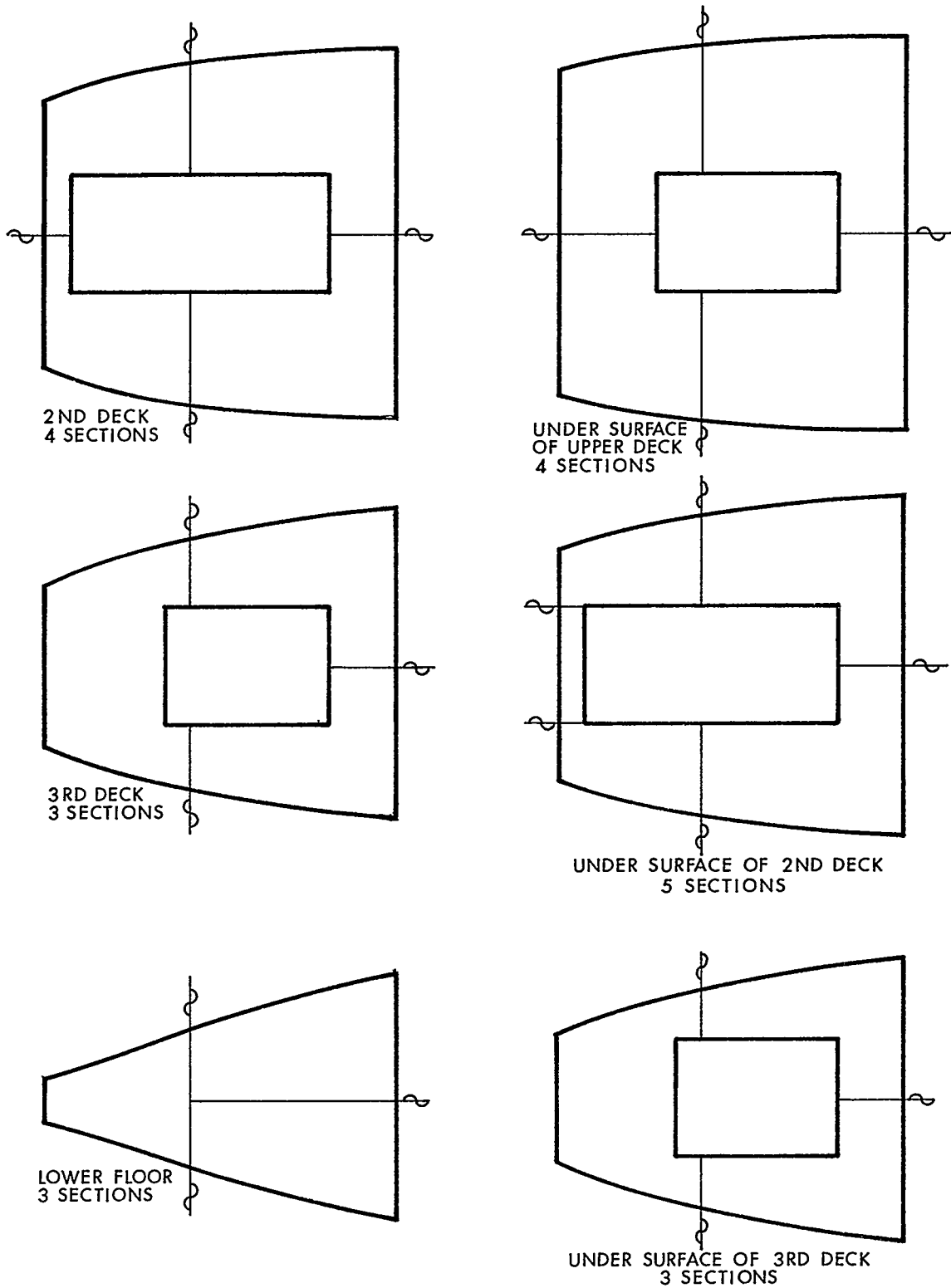

FIGURE 3-14(a): Typical Sectioning Scheme for a Diesel-Powered Engine-Room (Plan View).

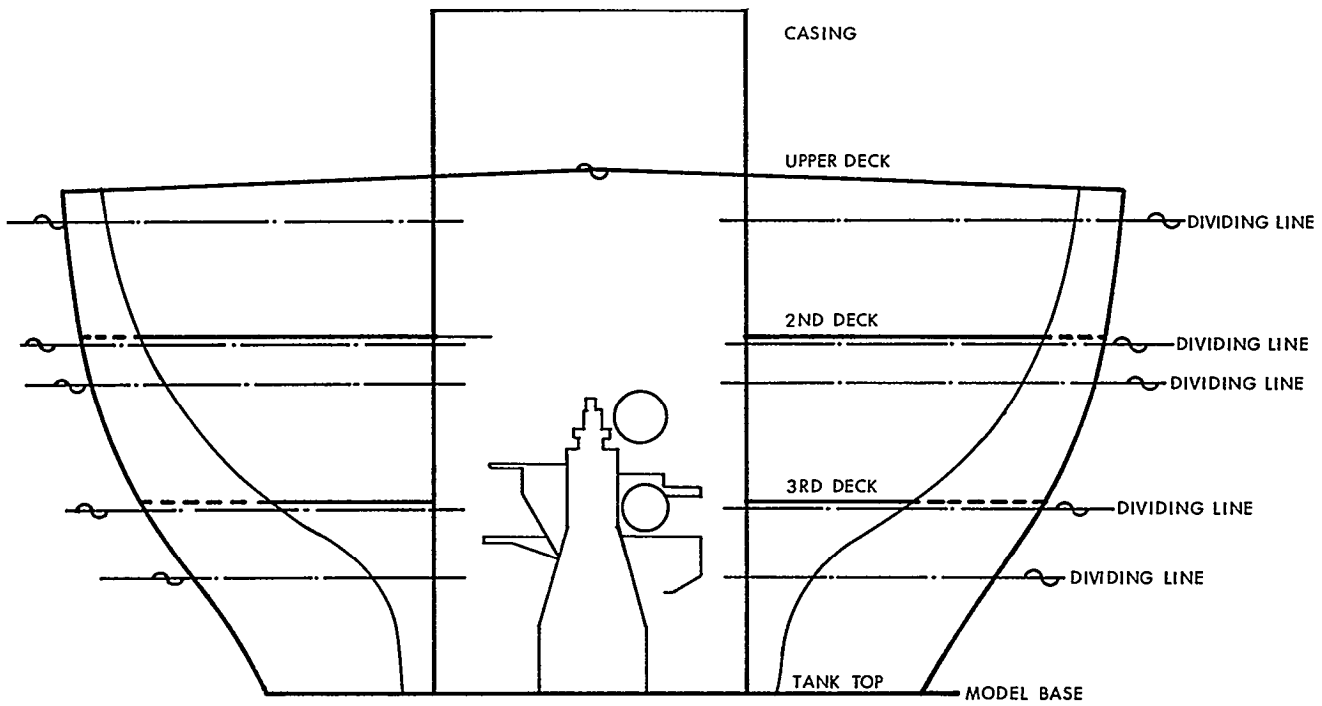

FIGURE 3-14(b): Typical Sectioning Scheme for a Diesel-Powered Engine-Room (Transverse View). The divisions through and between decks enables the model to be separated into sections so that more people can simultaneously participate in design modeling.

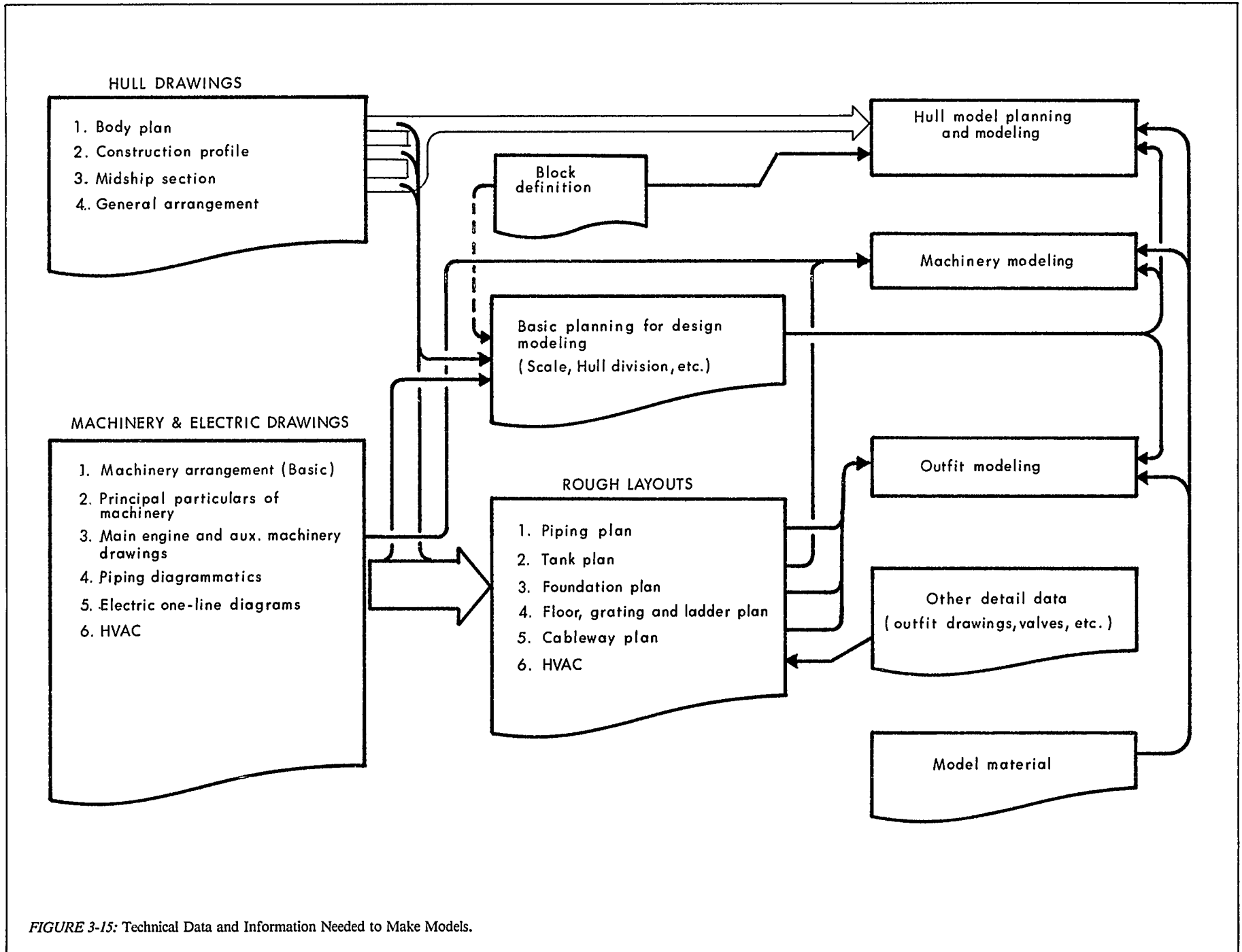

FIGURE 3-15: Technical Data and Information Needed to Make Models.

3.5.4 Required Information

A typical information flow as needed to perform design modeling is shown in Figure 3-15. Classifications are as follows:

- basic planning for design modeling,
- hull modeling,
 - machinery and fittings modeling, and
- model assembly.

Planning for design modeling should start before function design is completed. Therefore, basic-design documents are primarily used for the planning phase. In addition, much of the rough layouts used for modeling are derived from basic design. This information is supplemented by files of technical data and information which describes standard valves, strainers, flanges, pipe bends, elbows, ladders, etc. that are available to the design modeling team.

3.5.5 Selection and Control of Materials

With the exception of model bases which are made of wood, plastics are generally employed throughout a design model. Many plastic model parts are available as standard catalog items offered by model suppliers. Non-standard parts are custom made by model makers; see Figure 3-16. Thus, the collection and filing of up-to-date catalogs of materials available are very important functions that should be assigned to a design modeling team. Control of material starts with procurement of good quality materials at the best prices.

Quantities of each item are estimated from basic planning drawings or from previous design-modeling projects. Materials should be inspected upon receipt and stored in a fashion and location where they are readily accessible, e.g., pigeonholes, cabinets, shelves, etc. in a model-shop space allocated for such storage.

3.5.6 Detail Work Schedule

Performance of a design-modeling team on schedule and within an allocated man-hour budget is of vital importance. A typical detail work schedule for design modeling, as in Figure 3-17, is derived from the schedule for design modeling which was prepared from the shipbuilding schedule. The detail schedule is based on such considerations as:

- duration allocated for design modeling relative to a shipbuilding schedule,
- engine-room plan and space,
 - range of modeling,
- number of team members, and
- number of man-hours.

Inspection and checking are very important steps which should be scheduled just as actual modeling work. Concerned designers and field engineers should begin their inspections during the final stage of model assembly. A model then serves to facilitate discussion and confirm production plans and schedules for work assigned to shops.

Ideally, an owner's check should take place before pipe runs are installed and again at the final stage of design modeling. Designers should be prepared to employ the model for explaining matters concerning the machinery arrangement, pipe runs, etc. An owner's requirements for alteration should be carefully documented, accompanied by photographs, and signed by an authorized owner representative.

3.5.7 Design Modifications During Modeling

Figure 3-18 illustrates a communication system for control of design modifications and for notifying concerned organizations. When modifications are proposed, as a consequence of design development or an owner's request, the coordinator checks their impacts by:

- reviewing rough layouts with designers, and
- consulting with model makers.

Following such evaluations, the coordinator issues authority to effect changes and pertinent notices to concerned organizations.

3.5.8 Man-Hour Estimation

The man-hours needed for design modeling depend on the following:

- structural plan of engine room and space available,
- amounts of engine-room machinery and fittings,
- owner category,¹
- model scale, number of model sections, and number of different items to be modeled,
- degree of available modeling skill,
- coordination between people assigned to a design-modeling team, and
- accuracy required.

¹ Some shipbuilders categorize ships to be designed by the degree that owner preferences impact on costs, e.g., 1st European, 2nd Greek, 3rd Hong Kong, etc.

| MODEL PART | STATUS |
|---|----------------------------|
| HULL | NON-STANDARD |
| MACHINERY, MOTOR | { STANDARD NON-STANDARD |
| VALVE, PIPE, ELBOW, TEE | STANDARD |
| PIPE SUPPORT, TANK WALKWAY, CABLE TRAY } | NON-STANDARD |
| LADDER | STANDARD |
| FOUNDATION | NON-STANDARD |
| MODEL BASE | NON-STANDARD |

FIGURE 3-16: Typical Standard and Non-Standard Model Components. Standard components are available from model-supply firms.

Regarding the latter, accuracy required should be decided beforehand and should be no greater than that actually required as man-hour requirements increase exponentially with accuracy. The same order of accuracy does not have to exist everywhere.

Estimated man-hours for various aspects of design modeling are provided in Figure 3-19. As material accounts for only about 15% of design modeling costs, great attention should be given to reducing man-hours.

3.6 Rough Layouts

3.6.1 General

Performing design modeling from just the end products of function design would be very difficult and costly in time and man-hours. Necessarily, a model of a complex engine-room must be made section by section and completed in a relatively short time. In order to perform modeling work smoothly and efficiently, and also to realize a consistency in design throughout the entire process, rough layouts of pipes, fittings, electric-cable trays, ventilation ducts, walkways, gratings, ladders, etc. prior to model making are very important.

Rough layouts are necessary for:

- enabling designers and model makers to assess an engine room to be built as a total entity,
- preliminary knowledge of an entire engine-room outfit, i.e., knowledge of the kinds, numbers and positions of fittings,
- providing interface guidance to the various model makers who are to produce different model sections simultaneously, and
- investigating alternate arrangements which would be difficult to evaluate in the midst of model making.

A process for preparing layouts is shown in Figure 3-20. An important feature is immediate determination of main piping-routes because they are fundamental. Secondly, layouts of tanks, ventilation ducts, pipe runs, electric-cable trays, walkways, gratings, ladders, etc. are determined. Then, all layouts are compared and adjusted in order to achieve a well balanced distribution of pipe runs, tanks, etc. from a composite viewpoint.

3.6.2 Information Required in Advance

Prerequisite information for design modeling includes:

- Hull Drawings
 - general arrangement
 - midship section
 - construction profile
 - body plan
 - hull piping diagrammatics
- Machinery Drawings
 - basic machinery arrangement
 - machinery principal particulars
 - machinery pipe-connections and outlines
 - shafting arrangement
 - ventilation duct arrangement
 - electric diagrams (routes and sizes)

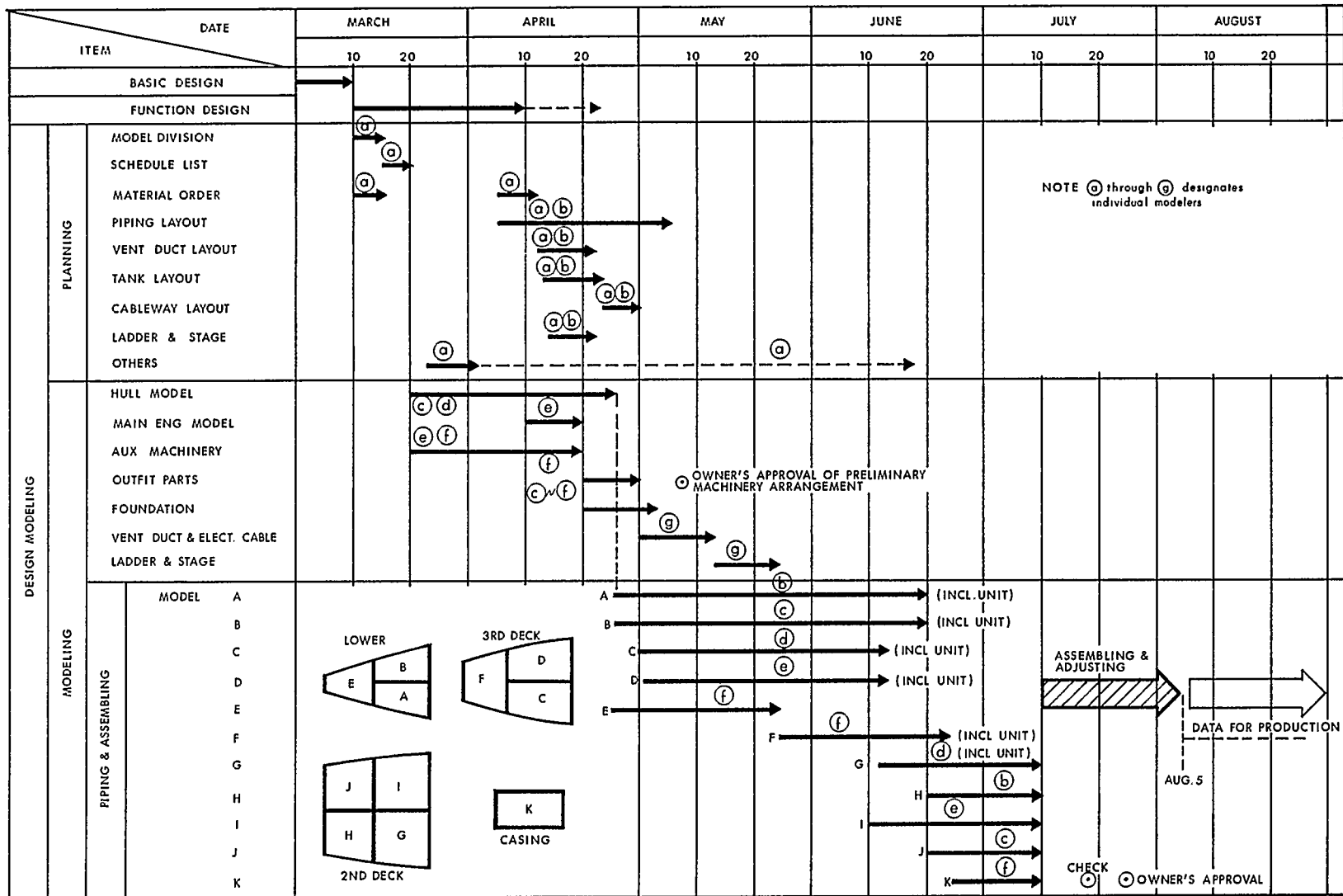

FIGURE 3-17: Detail Work Schedule for Design Modeling.

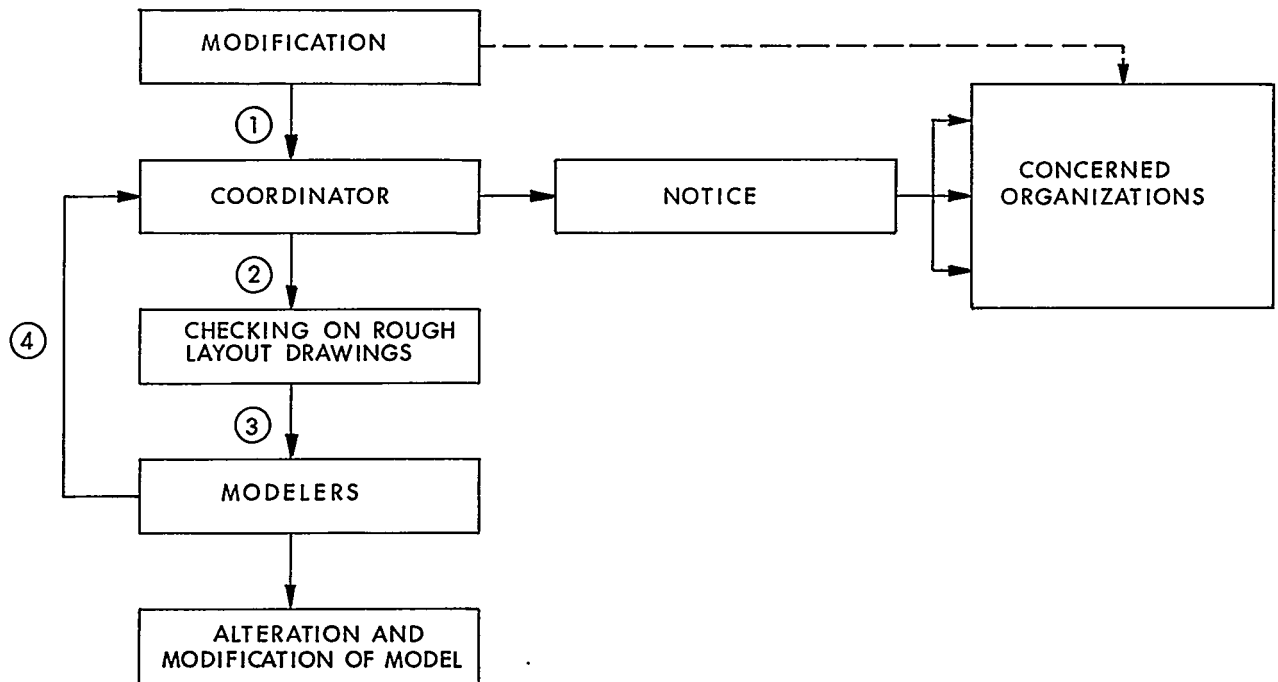

FIGURE 3-18: Communication and Information System for Design Modeling.

References

- tank arrangement (from previous ships)
- piping arrangement (photographs of models and drawings for other ships)
- fitting catalogs (special strainers, valves, etc.)
- lists of standard fittings

The above drawings and references are necessary not only for preparing rough layouts but also for model making. Even when special fittings are not precisely defined, rough-layout work should proceed based on best known catalog or other information.

3.6.3 Auxiliary Machinery Foundations

Foundations for large machinery items, e.g., diesel generator, boiler, etc. are usually designed by hull specialists because such foundations are integral with hull structure. As such structural details are generally not ready in time, models of these foundations are made per drawings from previously built ships having similar engine rooms.

After locations of other auxiliaries are determined, their foundations are roughly designed by members of a design-modeling team. Particular attention is given to pipe pieces and valves that will be immediately attached. A typical preliminary foundation design is shown in Figure 3-21.

Preliminary designs of auxiliary machinery foundations should be made together with rough layouts because regard for fittings, particularly valves attached to auxiliaries, often require alterations in piping layout-work. Foundation design also depends on whether fitting work is to be performed on unit or on block.

Initial foundation designs for auxiliary machinery usually require modification because of various design factors. With the aid of rough layouts, final foundation locations and designs are defined during model making.

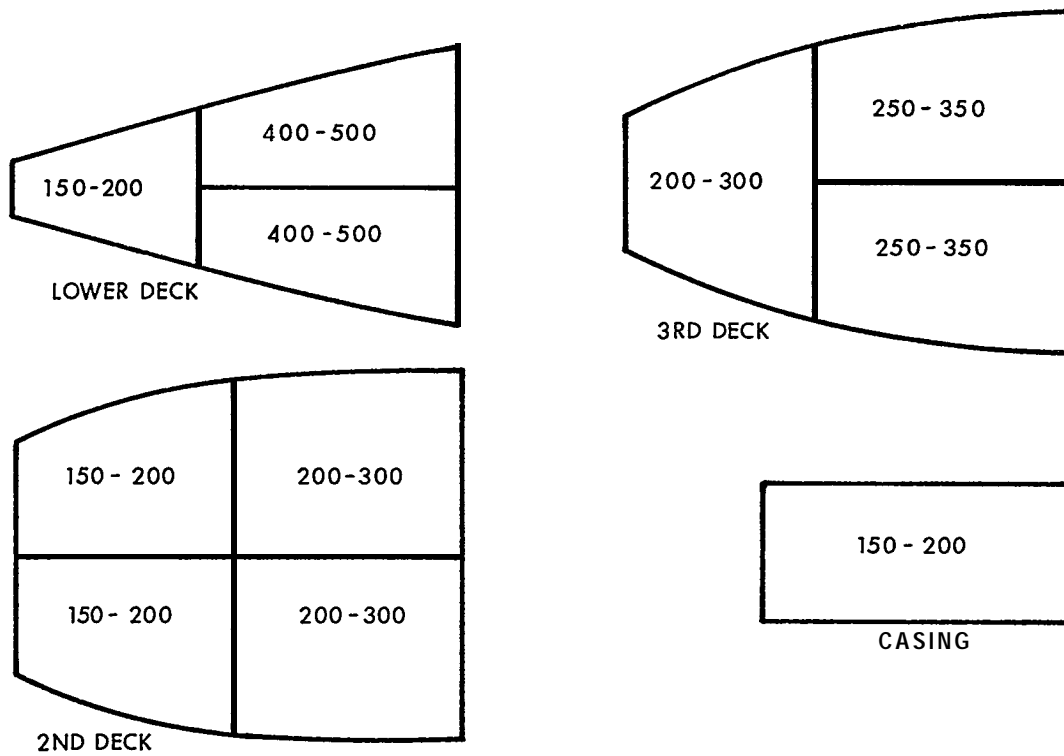

ESTIMATED NUMBERS OF MAN-HOURS BY SHIP SIZE

| <u>Tonnage (D.W.T.)</u> | <u>Planning (hours)</u> | <u>Modeling (hours)</u> |
|--------------------------|-------------------------|-------------------------|
| 20,000-100,000 | 800-1,000 | 3,000-4,500 |
| 100,000-200,000 | 1,000-1,200 | 4,000-5,500 |
| 200,000-400,000 | 1,200-1,600 | 5,000-6,500 |

**ESTIMATED NUMBERS OF MAN-HOURS BY FUNCTION FOR A SHIP OF
30,000-50,000 D.W.T.**

| | |
|-------------------------------|--------------------|
| Basic planning & rough layout | 800-1,000 hours |
| Hull modeling | 500- 600 |
| Machinery modeling | 300- 400 |
| Outfits & foundations | 200- 300 |
| Ducts, cable trays & others | |
| Piping & assembling | 2,000-3,000 |
| Total | 3,800-5,300 |

FIGURE 3-19: Estimated Man-Hours for Various Aspects of Design Modeling. When a design modeling process is accelerated, such as when rapid delivery of a ship is specified, design-modeling costs will increase.

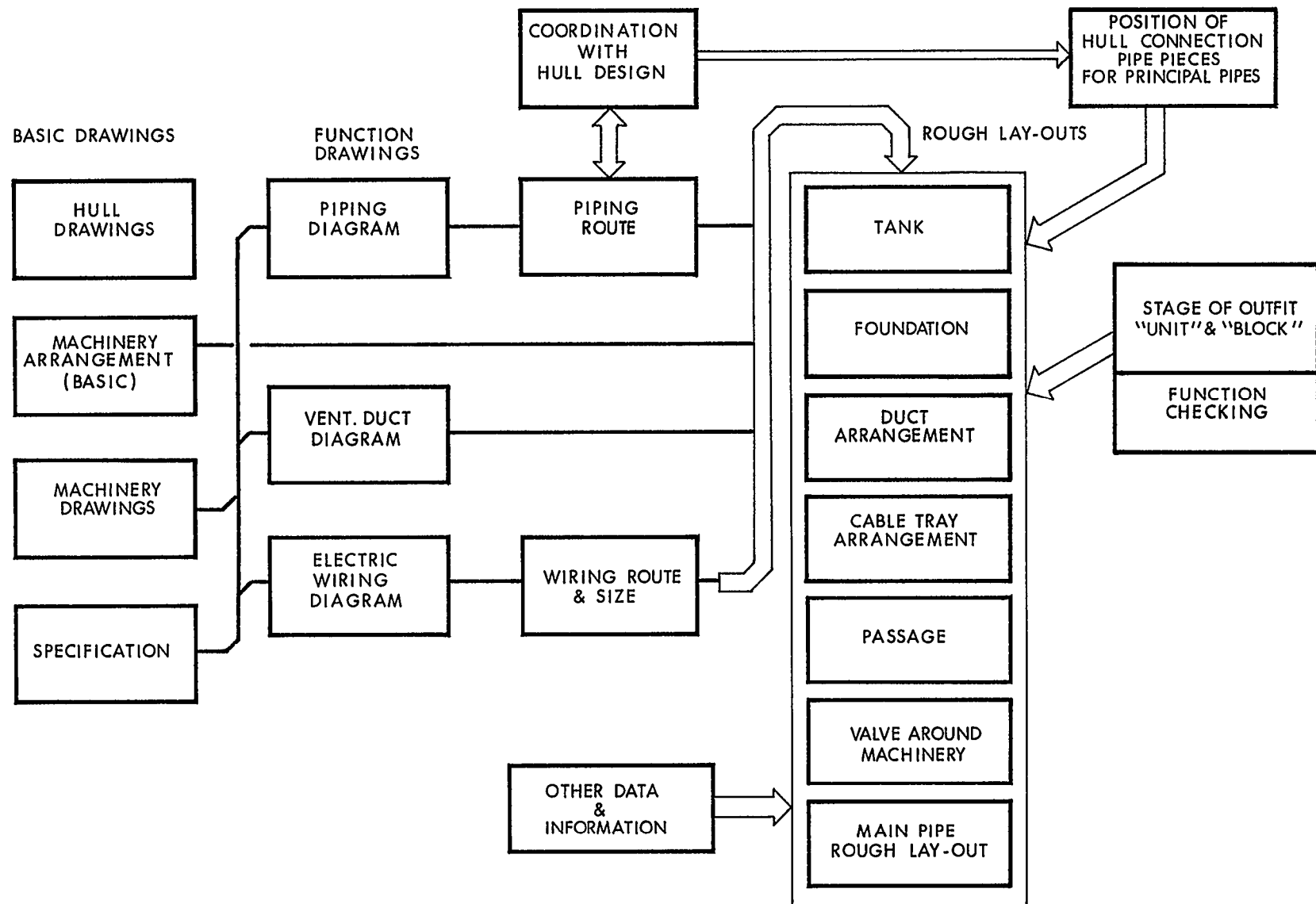

FIGURE 3-20: Process for Preparation of Rough-Layouts.

3.6.4 *Ventilation Ducts*

An approach for design-modeling ventilation ducts is shown in Figure 3-22. Factors to be considered include:

- ***Diagrammatics***

Figure 3-23 shows a typical ventilation-system diagrammatic. Air quantities, duct sizes and locations of outlets are first decided relative to an initial rough layout. Clear definition of outlets is very important. Duct sizes are determined based on calculations of air quantities and pressures. As a design develops, duct sizes and locations require changes. However, there should be a reasonable limit imposed to prevent needless fine tuning of ventilations systems.

- ***Locations***

The locations of relatively large ducts are, in most cases, finally determined in rough layouts. Locating ducts on ceilings requires careful coordination with positioning electric-cable trays and pipe runs. A preferred arrangement sequence for cable trays, pipe, and ducts is illustrated in Figure 3-24. Locating a tray above pipe runs, with ducts beneath or alongside, permits the use of common supports.

As vent ducts significantly affect the appearance of an engine room, they should be smartly arranged. When vent-duct planning is complete, locations, sizes and other dimensions are noted on rough layouts to serve as directions to model makers.

3.6.5 *Walkways, Gratings and Ladders*

Usually passages leading to accommodation spaces and main passages inside an engine room are approximated in basic general arrangements. Such drawings are employed for defining walkways, gratings and ladders. Heights and areas are defined in a design model but outlines and dimensions needed for preparing work instructions are superimposed on a basic general arrangement as shown in Figure 3-25. Particulars, such as for locating stanchions, grating appendages, auxiliary ladders, etc., are also determined during design modeling.

As diamond plate and grating materials are available in only a few standard sizes, walkways should be sized in exact multiple-s or simple fractions of the raw material dimensions. In addition to reducing scrap associated with relatively expensive materials, such standardization simplifies design, fabrication and assembly efforts.

3.6.6 *Tanks*

Approximate locations of tanks are given in basic general arrangements. As tank dimensions are closely related to their locations, both should be decided at the same time while considering factors such as locations of surrounding pipes, machinery, etc. Before final decisions are made regarding tank locations, installation, maintenance, inspection, painting and nearby hull configuration must be considered.

Positions of pipe nozzles on tanks are initially located in a piping rough-layout. They are finally located during model making. A process for locating a tank and producing its design details is shown in Figure 3-26.

3.6.7 *Cableways and Trays*

Routes and sizes for cableways and trays are roughly planned by electrical engineers based on diagrams superimposed on general-arrangement drawings. Next, *piping designers* decide rough positions of cableways together with those for pipe and duct runs. Particulars are determined during model making. See Figure 3-27.

3.6.8 *Piping*

A process for design-modeling pipe is depicted in Figure 3-28. Typical rough layouts are shown in Figures 3-29(a) and (b).

- ***Routes***

A route for each system functionally described in a diagrammatic is drawn freehand on a general arrangement. While dimensions and exact positions are not required at this stage, there must be clear definition concerning whether a pipe run is located at the lower floor, just beneath a specific ceiling, etc. Figure 3-30 is an example of such freehand definition for a lower-floor. Rough locations of pipe runs, their positions relative to other runs, and especially, pipe penetrations of hull structure are decided when such sketches are prepared.

Ž *Pipe and Valves Attached to Auxiliary Machinery*

Auxiliary machinery locations, and sometimes their foundations, are greatly affected by positions of their attached valves and pipe pieces and in the way pipe pieces must be directed toward other machines, etc. Thus, at the very beginning, there must be definition, as in Figure 3-31, of the immediately attached valves and pipe pieces. Afterwards, locations and positions for auxiliary machinery are finally determined.

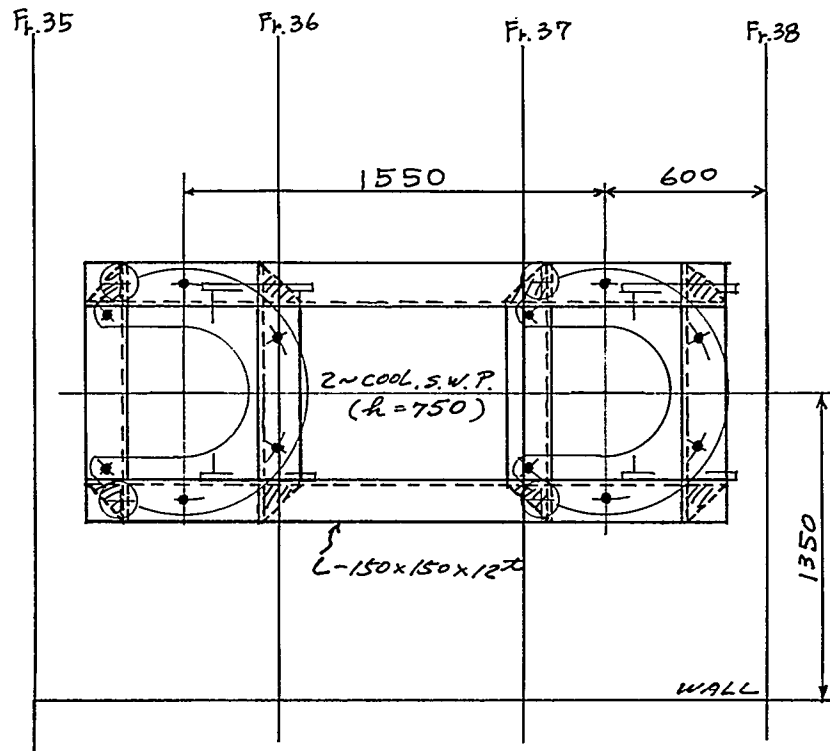

FIGURE 3-21: Typical Preliminary Design for Auxiliary-Machinery Foundations.

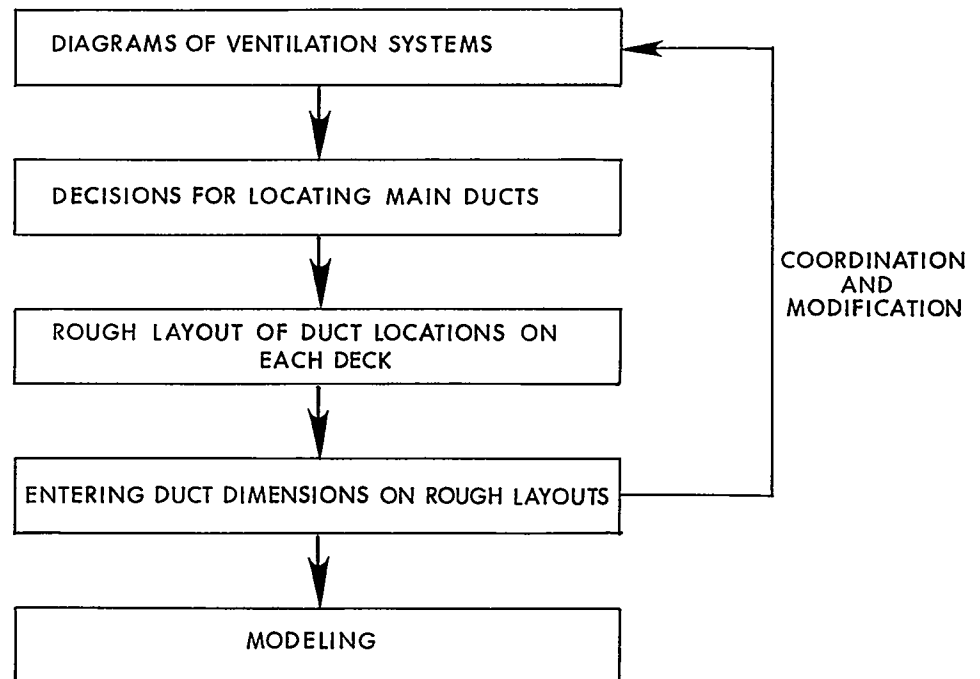

FIGURE 3-22: Approach for Design Modeling Ventilation Ducts.

| PARTICULARS OF FAN | | |
|------------------------------|--|---------|
| TYPE | VERTICAL AXIAL FLOW ELECTRIC DRIVEN | |
| | SUPPLY | EXHAUST |
| VOLUME (M ³ /MIN) | 600 | 360 |
| ST. PRESS. (MM Aq) | 30 | 10.8 |
| INLET DIA (MM) | 1000ϕ | |
| OUTLET DIA (MM) | 1000ϕ | |
| r.p.m. | 1150 | |
| MOTOR (KW) | 7.5 | |

No.1 FAN

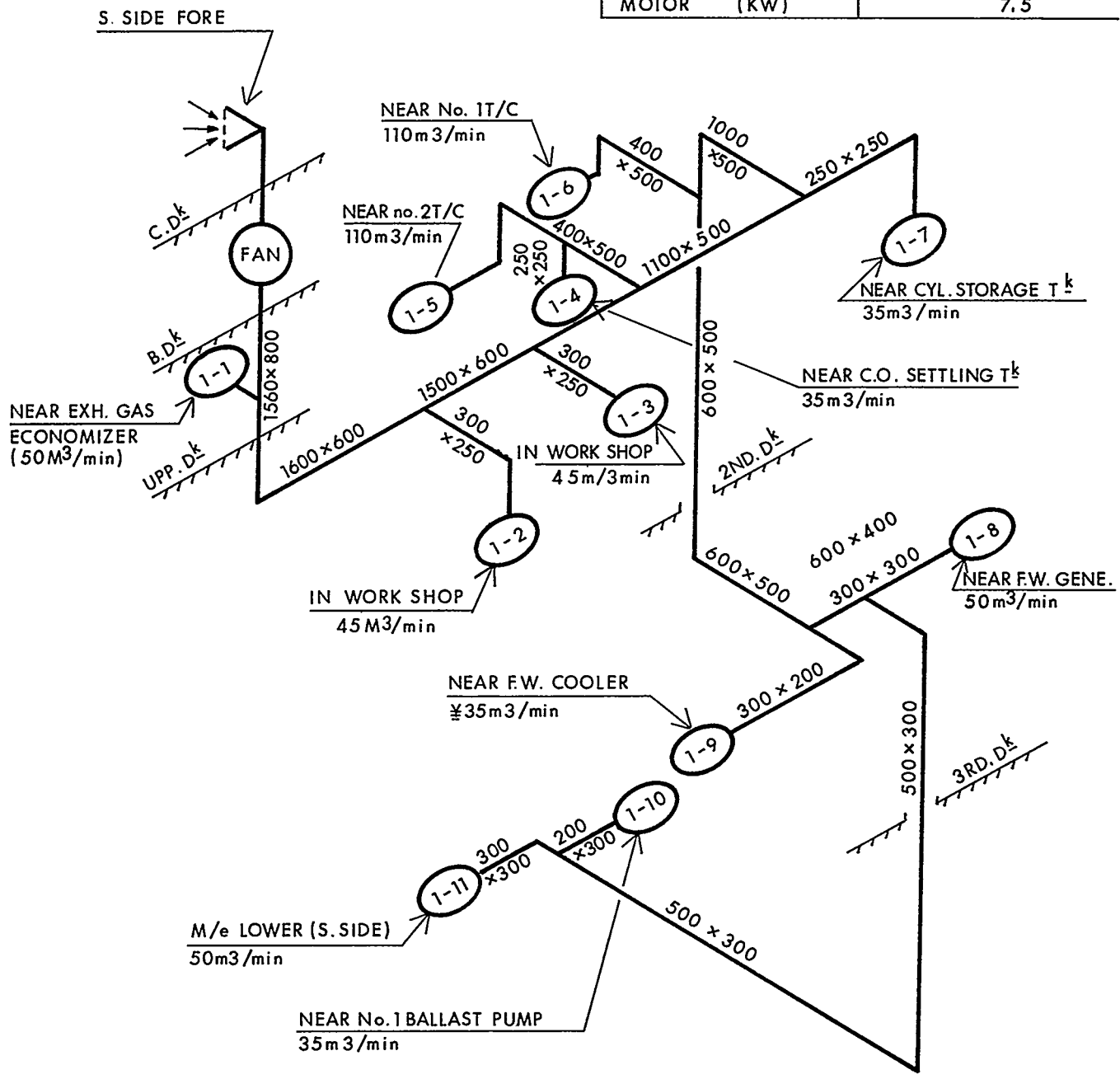

FIGURE 3-23: Diagram for an Engine-Room Ventilation System.

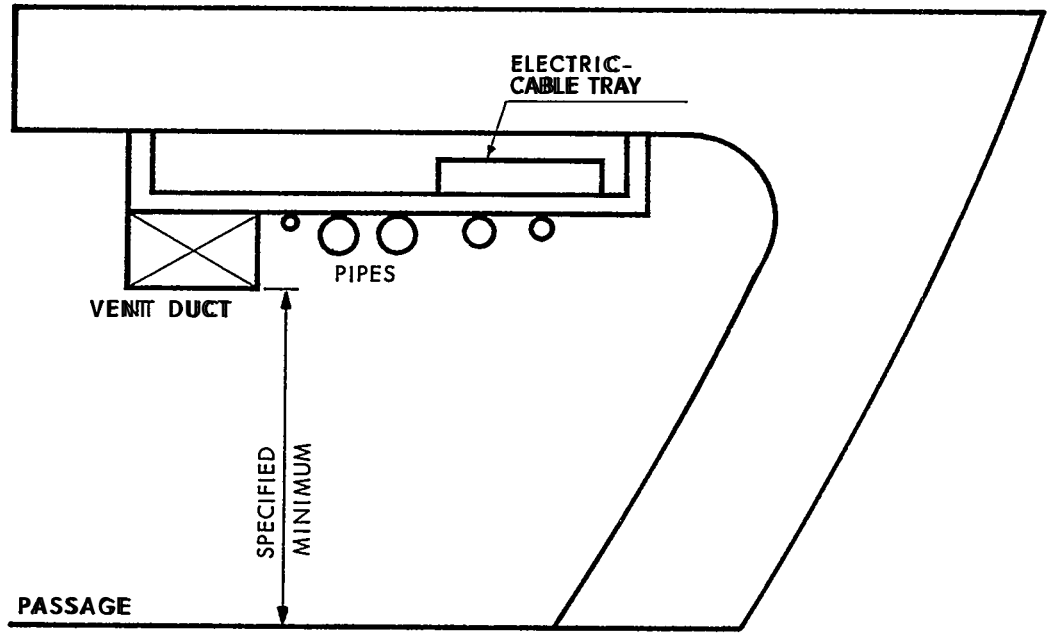
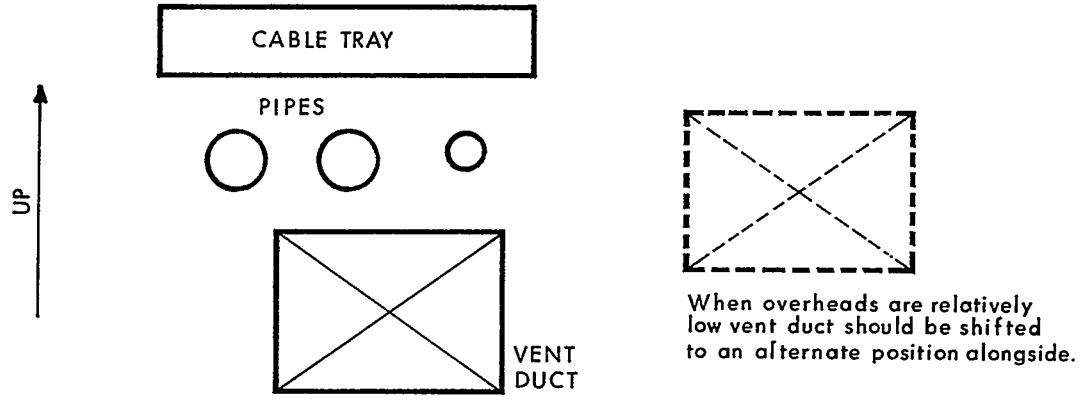

FIGURE 3-24: Locating Ventilation Ducts.

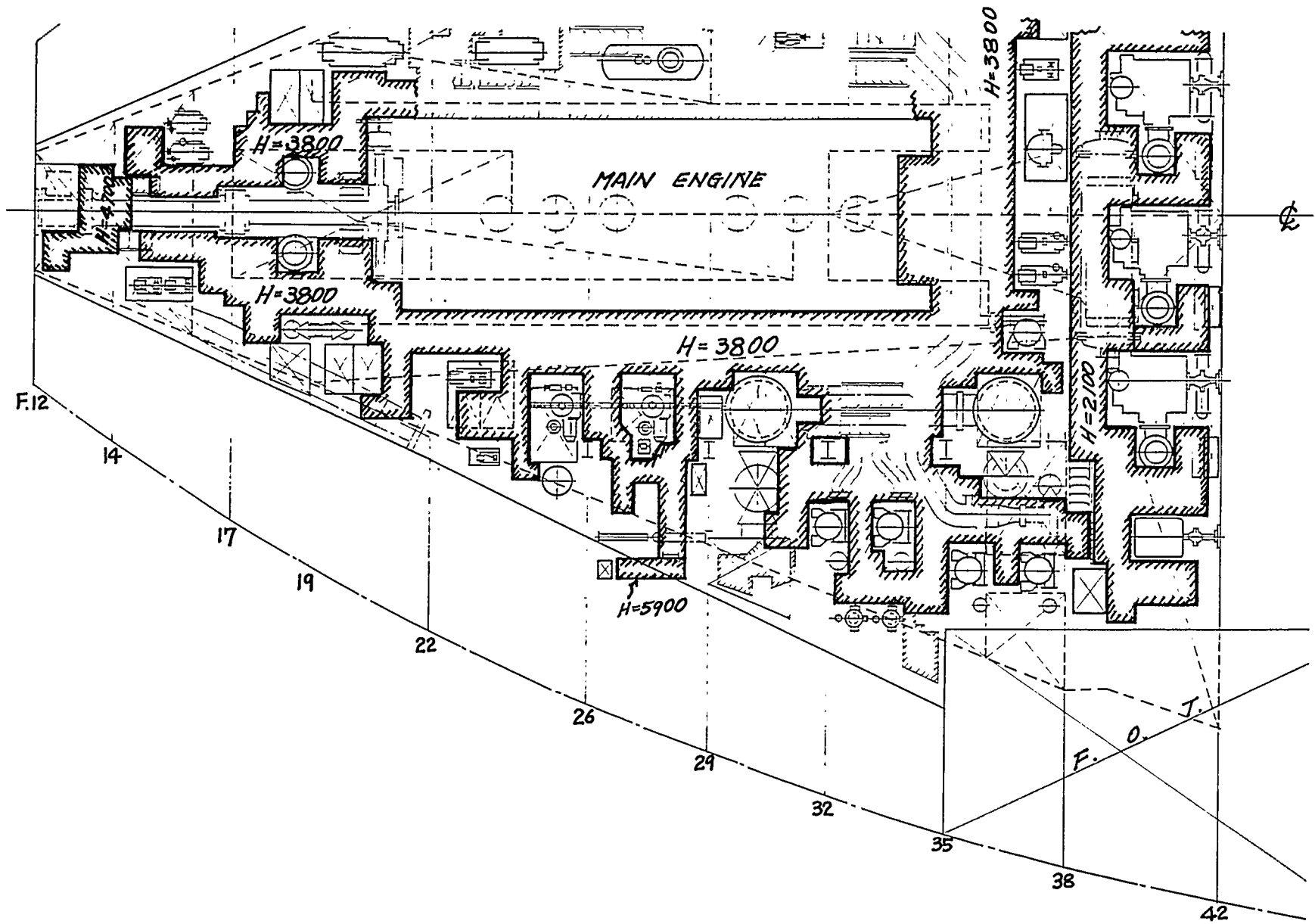

FIGURE 3-25: Walkways Above a Tank Top Superimposed on a Basic Machinery Arrangement. Heights of the various walkway regions are noted, e.g., $H = 3,800$ millimeters.

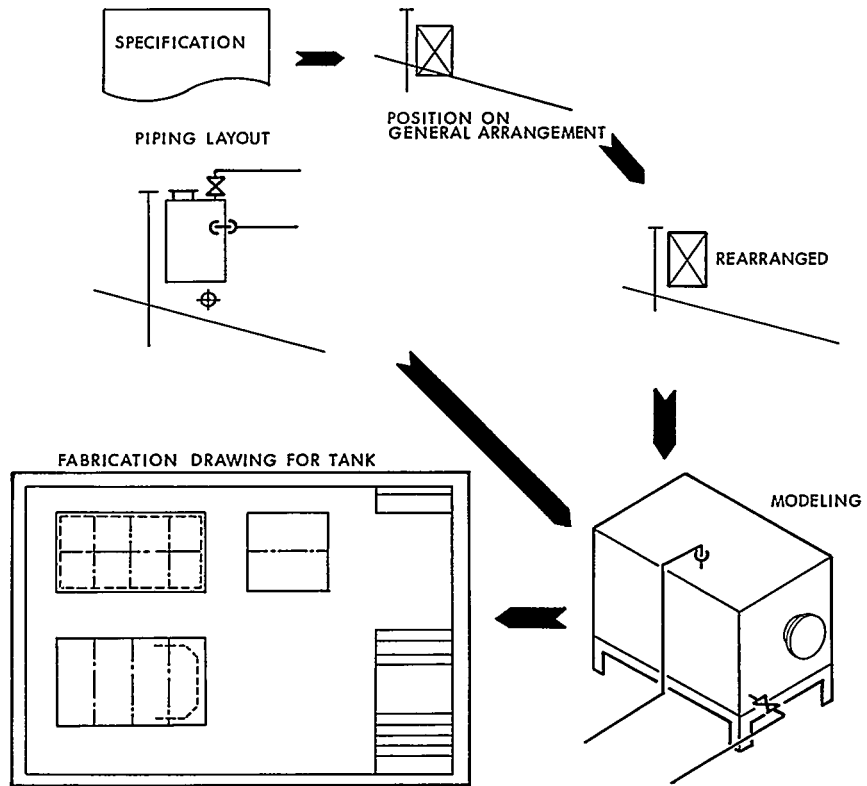

FIGURE 3-26: Design Modeling a Tank.

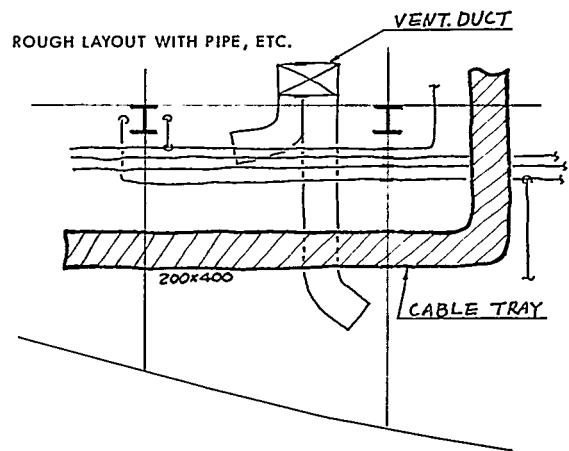
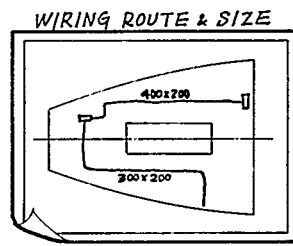
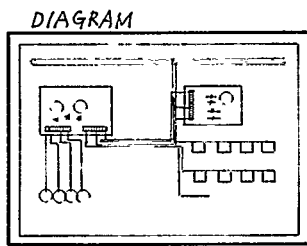

FIGURE 3-27: Freehand Layout for Cableways and Trays.

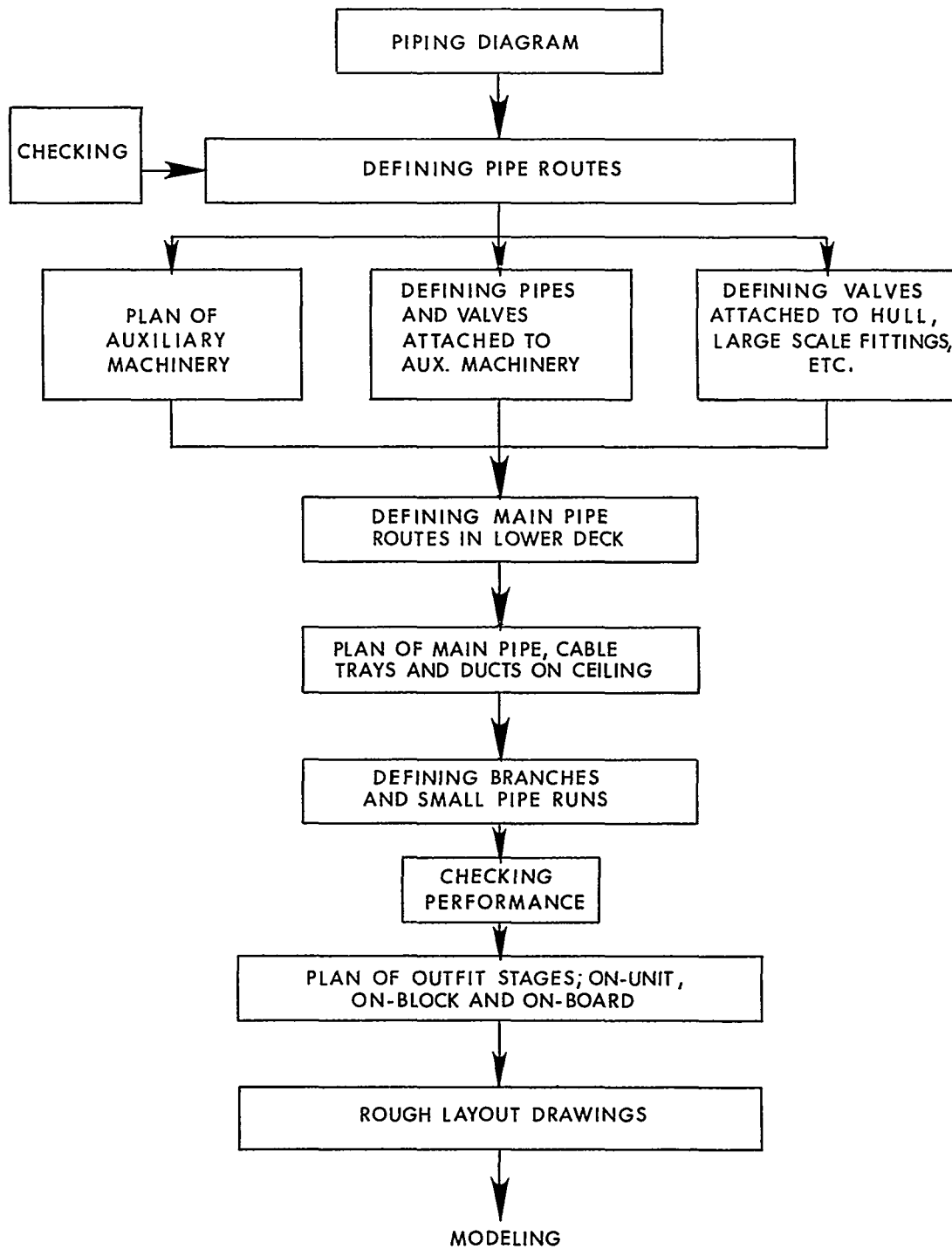
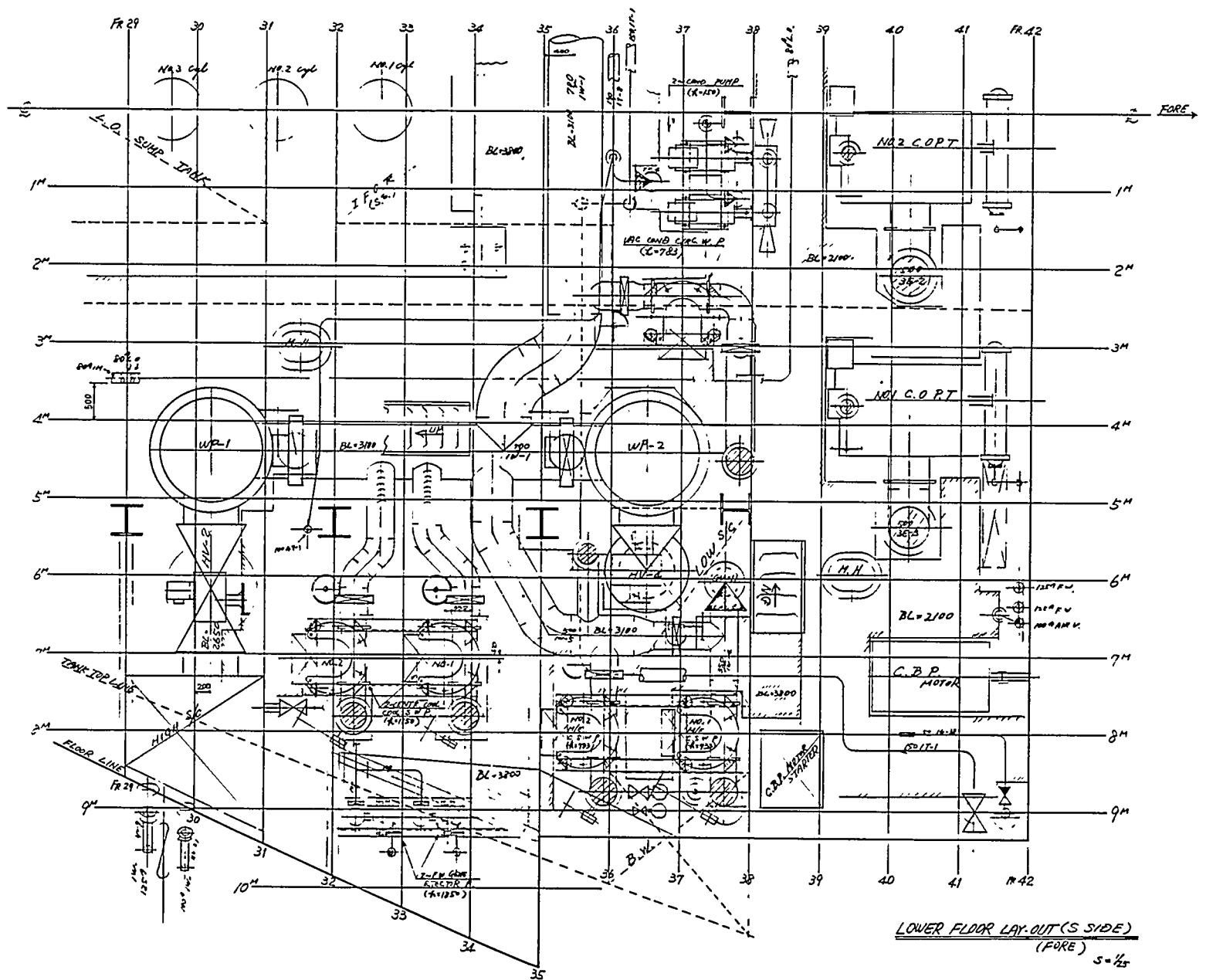

FIGURE 3-28: Design Modeling Pipe Runs.



LOWER FLOOR LAY-OUT (S SIDE)
(FORE)
S = 1/2

FIGURE 3-29(a): Rough Layout for an Engine-Room (Lower Floor).

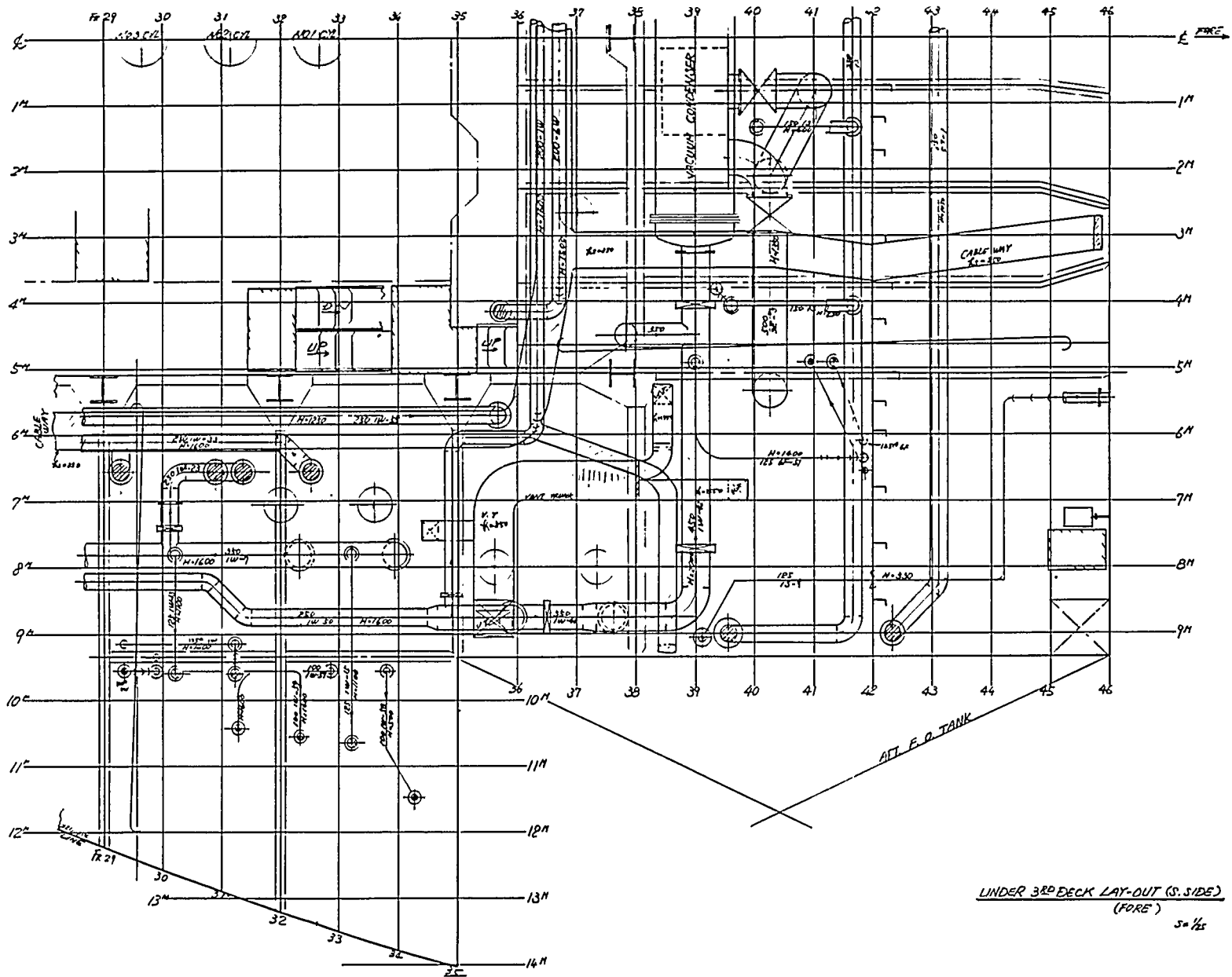

FIGURE 3-29(b): Rough Layout for an Engine-Room (Under 3rd Deck).

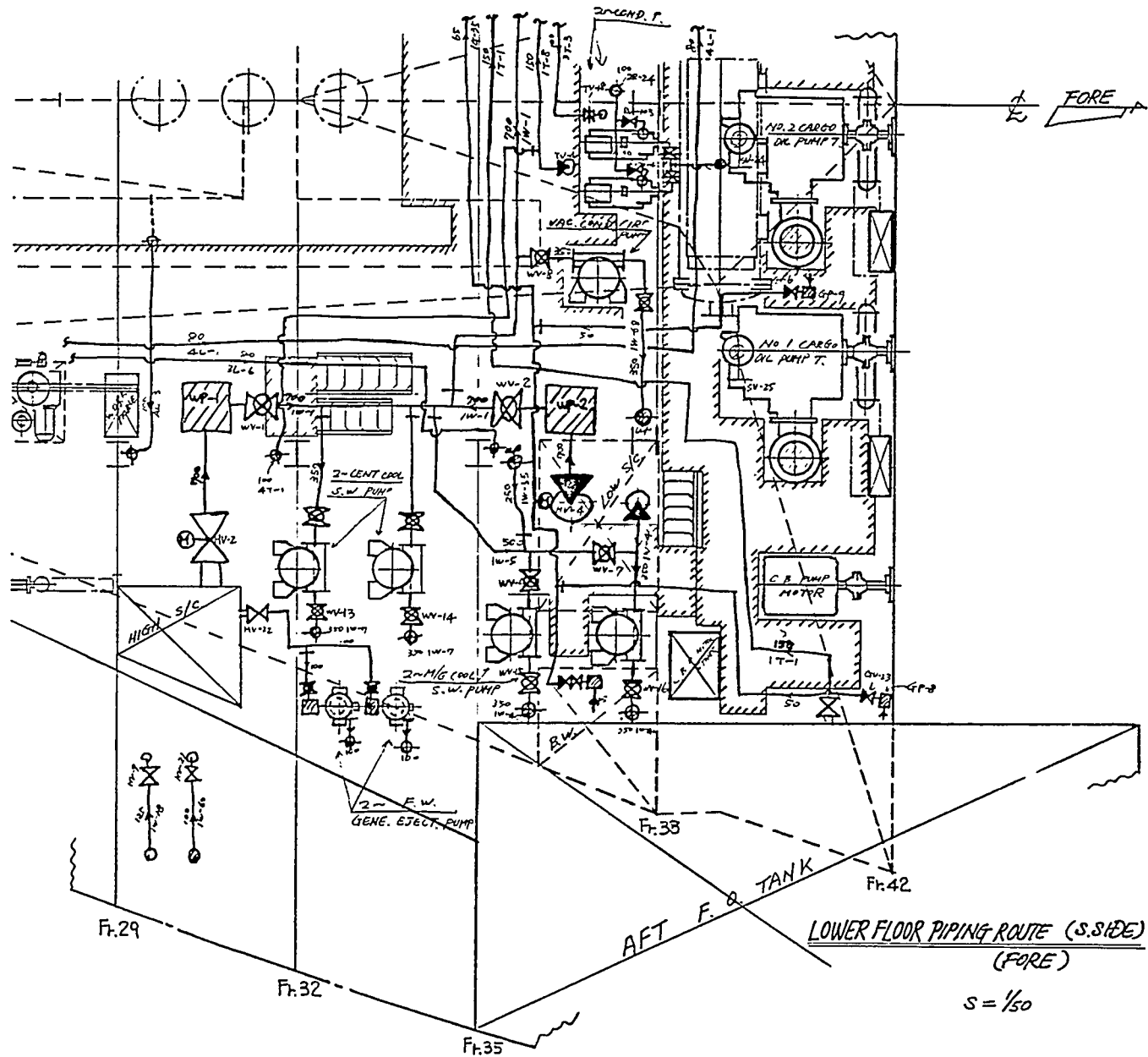

FIGURE 3-30: Defining Pipe Routes.

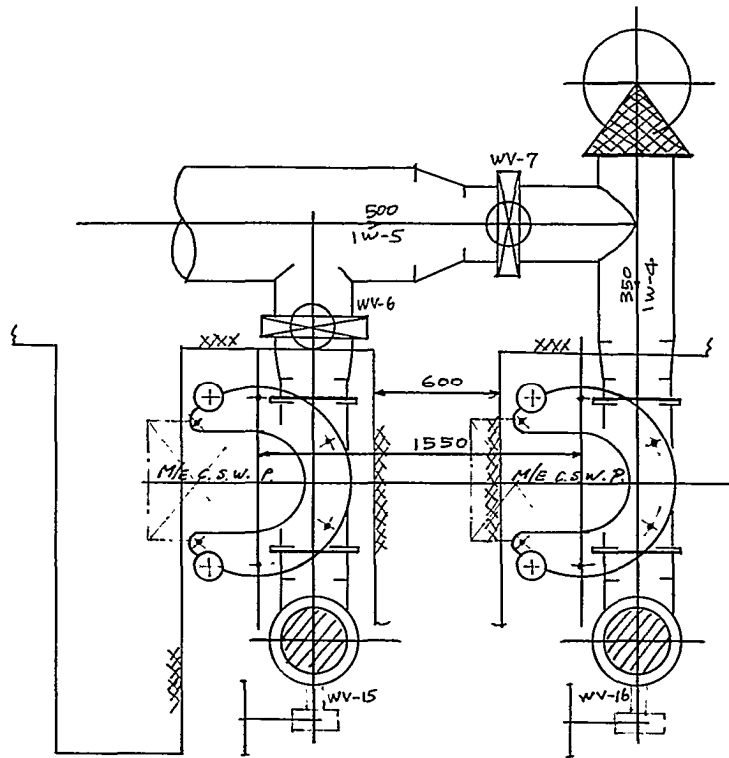

FIGURE 3-31: Defining Pipes and Valves Attached to Auxiliary Machinery.

Maintaining suitable open spaces for operational and maintenance matters in the vicinity of auxiliary machinery is also of prime concern. During such definition, standard machinery and fittings, and arrangements from previous designs can often be directly applied for the purpose of saving design man-hours and enhancing progress.

Along with such activity, rough definition should be made for sea valves, valves for fuel- and lubricating-oil strainers, and valves for bilge and ballast systems, as collectively they occupy a large part of the space available at the lower floor.

This preliminary definition is a great aid for efficient design modeling in a particularly difficult region.

Main Piping

Usually a clear idea of a main-piping arrangement is very useful during definition of pipes and valves attached to machinery. Therefore, main piping should be defined along with other items addressed in rough layouts. Main pipes are those of comparatively large diameter (more than 100 mm) and of functional importance. They should be assigned the same priority during layout work as for auxiliary machinery.

Planning for main piping begins at a tank top and progresses upwards. In other words, a recommended order of planning is:

- 1st - horizontal runs on tank top
- 2nd - vertical runs to first ceiling
- 3rd - horizontal runs under ceiling and so on for remaining engine-room flats

The locations where branch pipes are to join are also indicated on rough layouts.

- **Branch and Small Pipes**

Usually branch and small diameter pipes, particularly if they are of relatively little functional importance, are omitted from rough layouts. They are modeled directly from the route guidance contained in roughly arranged diagrammatics as shown in Figure 3-30. Such diagrams are annotated with information about size and rough dimensions for positioning so that they may be easily modeled.

However, branch and small diameter pipes which are numerous and closely associated so as to require a complicated arrangement, e.g., suction and discharges for lube-oil purifiers, should be planned in rough layouts to facilitate modeling.

Runs of many small pipes in parallel can be simply represented in a model by some means, as for cableways, to show the space reserved.

- **Coordination**

The following should be carefully coordinated with the various design groups during rough-layout work in order to save man-hours and time required for design modeling:

- locations and positions of pipes which penetrate engine-room boundaries, e.g., pipes which penetrate a tank-top, pass through engine-room bulkheads or which enter accommodation spaces,
- design alterations of hull structure,
- laying out manholes, and
- laying out electrical fittings.

- **Checking**

In order to achieve optimum operation and in order to save materials and weight, checks should be made to insure that the lengths of pipe runs are minimized. Simultaneous checks should insure that pipe runs are straight and parallel and that bends other than 90 and 45 degrees are not unnecessarily employed.²

The following items should be checked, particularly during rough layout-work and when apprentice modelers are to participate, in order to minimize man-hours and time spent for implementing changes during modeling:

- exhaust and main-steam pipes including expansion joints and loops and their special supports,
- cooling-water piping (includes fresh water systems),
- fuel-oil piping, and
- lubricating-oil piping.

Special checks should be made for:

- pipe slopes and heights, and
- obstructions and interferences.

Checks to confirm that each piping system will function as prescribed on its diagrammatic should be made after completion of an entire engine-room model. Further, certain high-temperature and pressure systems require system A&D drawings for regulatory approvals.

²In the most effective shipyards, at least 30% of the pipe pieces defined for fabrication are straight or pieces that are fabricated as straight but bent in the final process, i.e., after welding of flanges and finished grinding. Limiting bends to 90 and 45 degrees as much as possible facilitates statistical control of pipe-piece manufacturing.

4.0 HULL MODELING

The various sections of a hull model when assembled comprise the framework on which modeled outfit units and components are assembled and fixed. In order to avoid unnecessary costs:

- parts of the hull which are not imperative for design modeling, e.g., shell plates should not be included except only as needed to fix overboard connections,
- parts of the hull which will be in very close proximity to fittings, e.g., columns and face plates on webs, should be of a different color than other structural members,
- complicated structural details which are not significant for outfitting should be omitted, and
- an accuracy plan and required tolerances should be discriminating, i.e., the same level of accuracy is not required everywhere.

Prerequisites for structural aspects of hull models are

- sufficient strength to bear the weight of fittings and to permit transportation without damage.
- sectionalization to facilitate placing and fitting modeled outfit units and components and to provide good "camera" access.

4.1 Material and Colors

Transparent acrylic-plastic sheets are most suitable for modeling hull structure. Suggested thicknesses and color requirements for various types of structure are given in Figure 4-1.

| | | |
|--|-----------|----------------------------------|
| TANK-TOP PLATE (also serves as model base) | 5 mm | COLORLESS TRANSPARENT |
| DECK CEILING | 3 or 5 mm | COLORLESS TRANSPARENT |
| BULKHEAD | | |
| FRAME | | |
| GIRDER | 3 mm | COLORLESS OR BLUE TRANSPARENT |
| FACE PLATE | 2 mm | BLUE TRANSPARENT |
| BRACKET | | |
| COLUMN | | |
| MANHOLE | | |

FIGURE 4-1: Thickness and Color Schemes for Modeling Hull Structure. Scale 1:15.

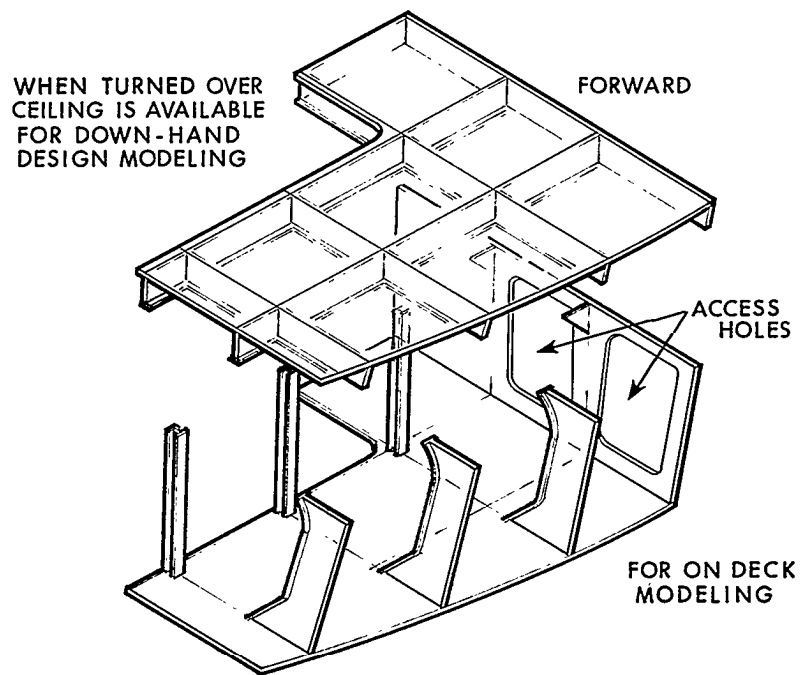

FIGURE 4-2: Separation of an Engine-Room Flat. Such separation facilitates both fitting on the deck below and down-hand fitting on the ceiling when the flat is turned over.

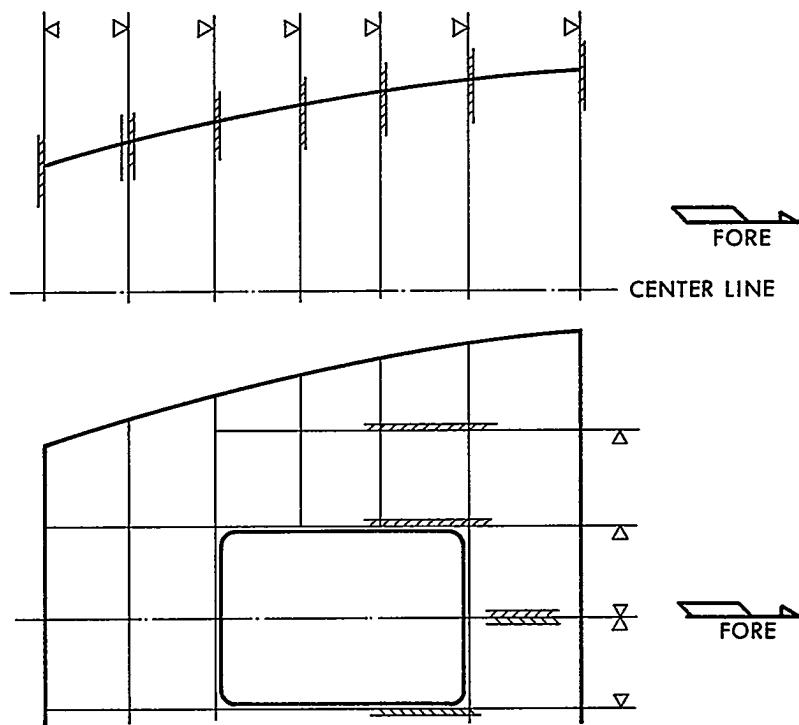

FIGURE 4-3: Reference Lines for Dimensioning (Plan Views).

4.2 Sectioning

Sectioning, typically illustrated in Figures 3-13 through 3-14(b), should:

- achieve section lengths of more than 600 mm and, for stiffness, not more than 800 mm,
- feature ceilings, as shown in Figure 4-2, which can be removed to permit modeling *down-hand* on the deck below, and when the ceiling is turned over, modeling *down-hand* on the ceiling, and
- **if necessary, feature removable bulkheads or access holes in bulkheads.**

In order to facilitate placement of a modeled ceiling when assembling hull-model sections, the columns, webs and bulkhead forward are glued to the deck below as shown in Figure 4-2. In constructing a real ship, columns, webs and enveloping forward bulkhead and side shell are more likely to be welded to the deck above.

4.3 Dimensioning and Accuracy

4.3.1 Dimensioning

Acrylic-plastic sheets of 3 to 5 mm thickness, necessary for model strength, are not representative of actual deck and bulkhead thicknesses. Therefore, a plan for dimensioning within a structural model must be carefully devised beforehand. Typical reference lines and surfaces for dimensioning are shown in Figures 4-3 and 4-4.

4.3.2 Tolerances

During actual-ship construction, tolerances routinely achieved by some shipbuilders are:

length ± 50 mm per 100 m,

width ± 15 mm for 15 m or more, and

depth ± 10 mm for 10 m or more.

Considering the foregoing and for an engine room to be about 30-meters long in full scale, practical hull-model tolerances are:

length ± 1 mm,

width ± 1 mm, and

depth ± 1 mm (above tank top).

4.3.3 Reference Lines

In order to facilitate attaching and assembling modeled parts, reference and stiffener lines should be scribed at scaled distances on modeled hull structure as follows:

- **upper surface of tank top - frame lines and 1-meter apart buttock lines,**
- **each deck - frame lines, longitudinal-stiffener lines and 1-meter apart buttock lines,**
- each bulkhead - stiffener lines and 1-meter apart waterlines which are relative to the upper tank-top surface,
- engine casing - frame lines, stiffener lines and 1-meter apart waterlines which are relative to the upper tank-top surface, and
- engine-casing top - frame lines, longitudinal stiffener lines and buttock lines.

4.4 Model Assembly Drawings.

Isometric assembly sketches and part fabrication sketches, respectively shown in Figures 4-5 and 4-6, should be prepared for each model section in advance of model making. Preferably, part numbers should appear on the assembly sketches so that corresponding numbers on fabrication sketches may be easily related. In addition to part numbers, the part name, quantity required and dimensions should be annotated on fabrication sketches.

Structural details which are frequently omitted or represented in simplified form include:

- shell plates,
- longitudinal deck stiffeners,
- carlings,
- doublers,
- collars,
- lightning holes,
- access holes.

When required, details of the foregoing are sometimes represented on acrylic-plastic surfaces in quick-drying ink. Coamings, the swings of doors, etc. are similarly represented.

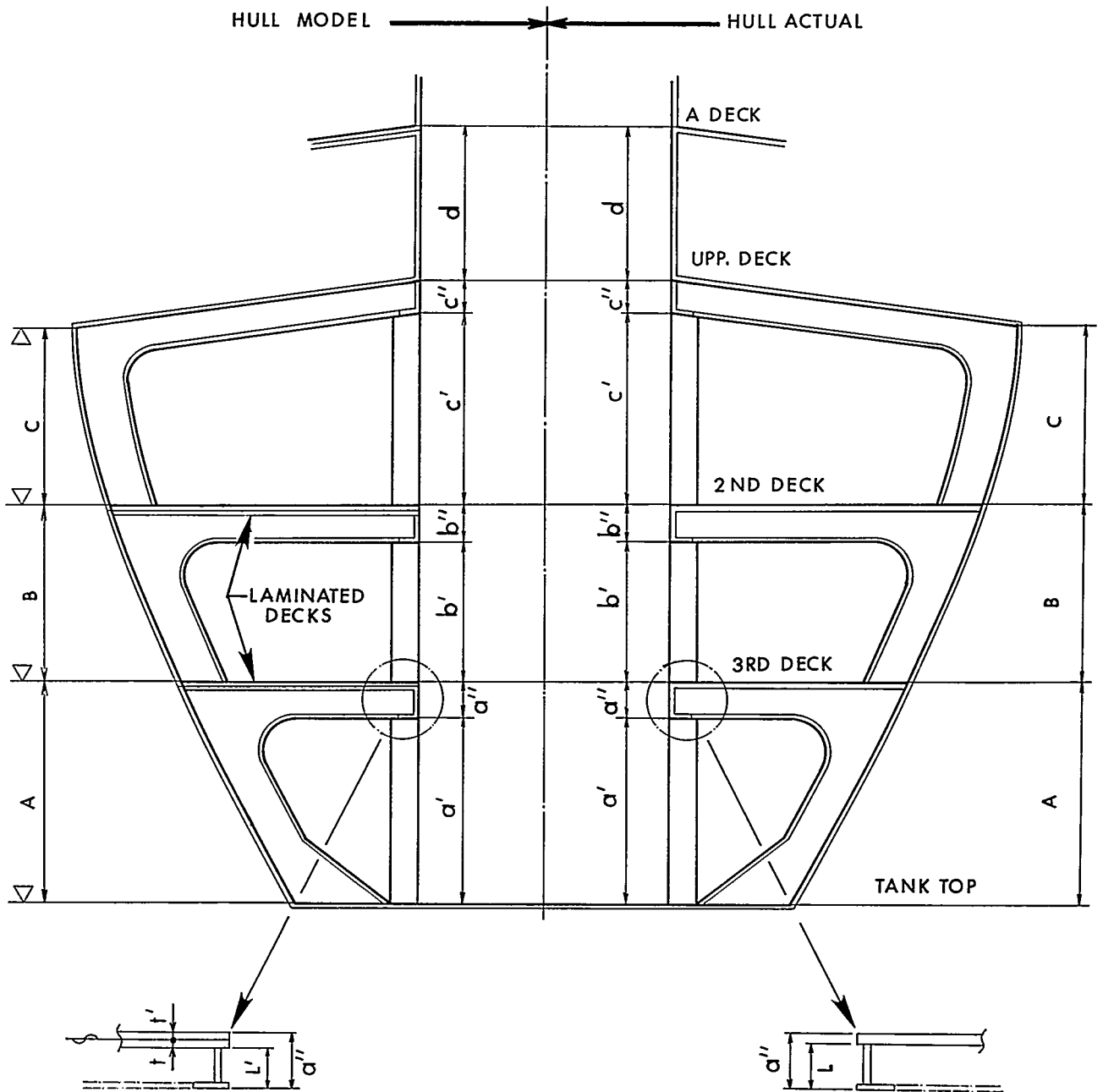

FIGURE 4-4: Dimensioning Heights in a Hull Model. For on-deck modeling, dimensioning is always to the deck surface. For on-ceiling modeling, dimensioning is always to the ceiling surface and supplemented by an allowance because the modeled decks must be considerably thicker than scaled thicknesses. For example, dimensions A, a', and a'' each represent the same dimensions in the actual hull and the model. People making measurements from model ceilings, must maintain awareness that the girder depth L' in the model is necessarily smaller than a scaled version of L for the actual hull. Thus the allowance to be added when measuring from ceilings is represented by L minus L' .

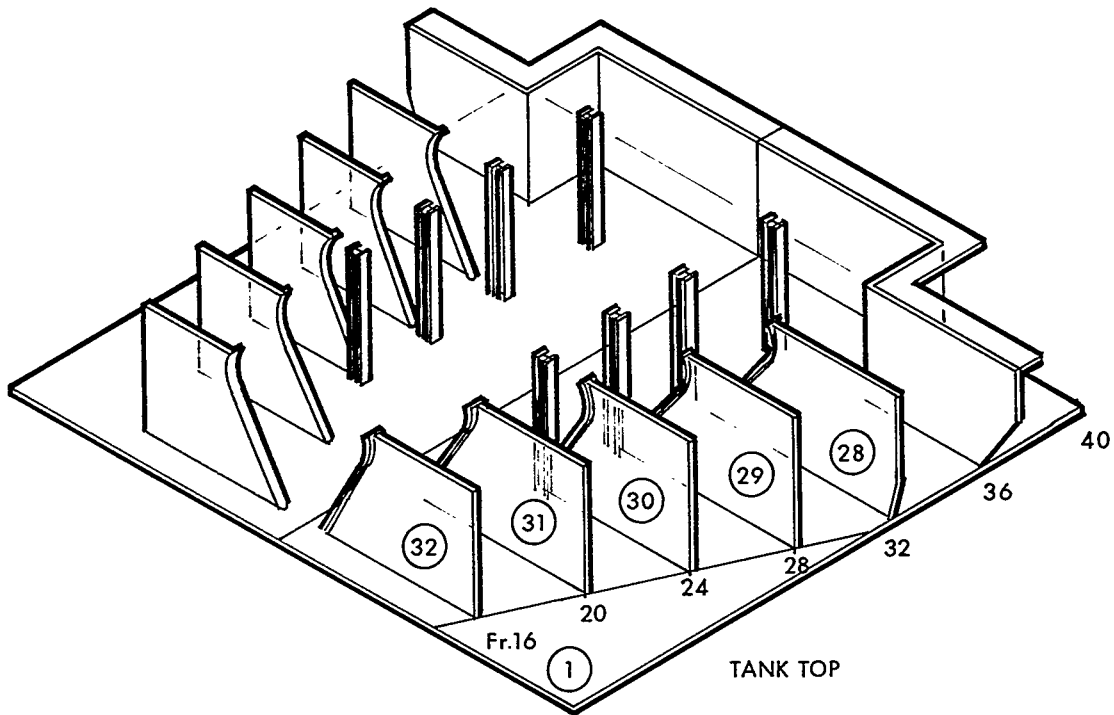
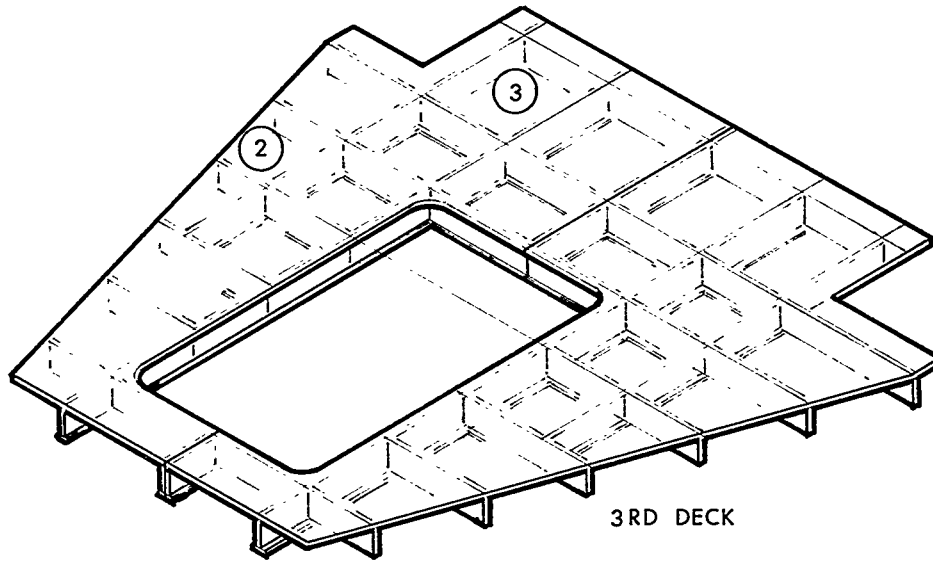
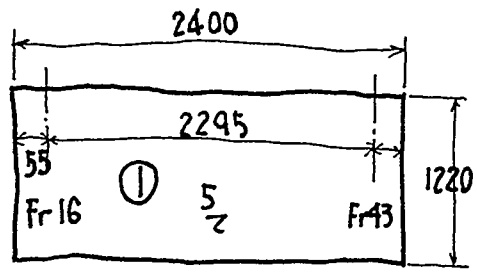
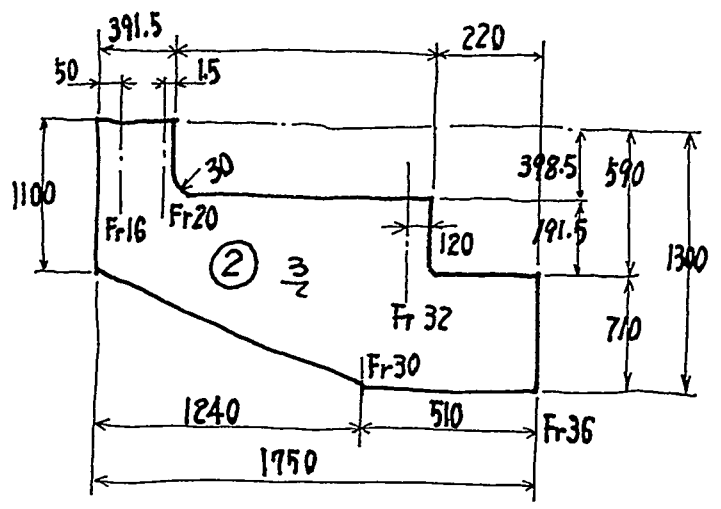

FIGURE 4-5: Isometric Views to Facilitate Assembly.



T. TOP PLATE 2SET



3RD DE PLATE 2SET

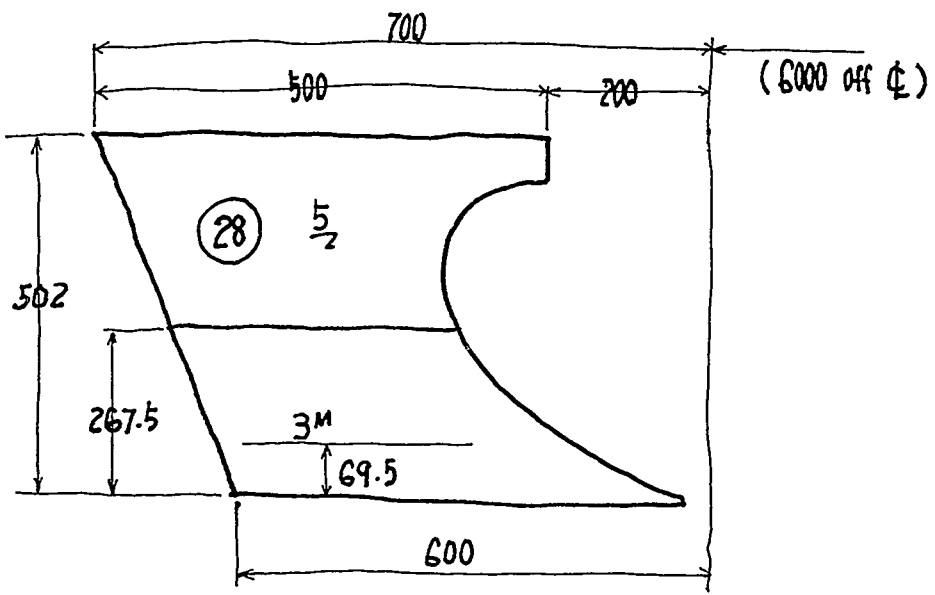

Fr 32 . 2SET

FIGURE 4-6: Freehand Sketches of Hull-Model Parts.

4.5 Construction

4.5.1 Model Bases and Tank Tops

As model bases are foundations on which entire models are assembled, particular care should be given to their accuracy and rectangularity. Usually division of a base into three sections as shown in Figure 4-7 is appropriate for a typical engine room. Sometimes two sections are sufficient. Dimensionally-stable clear pine or equivalent is used for the sides of each base section and a good grade of plywood suffices for the tops.

Acrylic plastic sheets representing a tank top are fixed to the plywood surfaces with screws. The projections of inner-bottom tanks are marked on the tank top as illustrated in Figure 4-8.

4.5.2 Shell Plating

Usually shell plates are not represented in a hull model because they inhibit placement of modeled fittings and photographic access. If not so obstructive, shell plates are sometimes included for reinforcing a hull model.

4.5.3 Frames

The inner contours of web frames with flanges should reflect the real ship-structure. The flanges should be made from different color plastic, light blue is suggested, so that they are readily apparent.

As illustrated in Figure 4-9, the outer contour of a web frame can be simply represented as a scribed line highlighted by a narrow strip of shaded adhesive tape. The plastic sheet from which the web frame is modeled, is allowed to extend beyond the molded shell whenever strength of the assembled model is a consideration. Frames other than web frames are omitted.

4.5.4 Girders, Beams and Sea Chests

All main girders and transom beams are modeled complete with flanges. Generally, ordinary beams and longitudinals are not modeled. Instead, they are marked, as are sea chests, as shown in Figure 4-10. Sea chests, as also shown in the figure, are sometimes represented with a solid block.

4.5.5 Decks

Engine-room flats, as shown for the 2nd and 3rd decks in Figure 4-4, are each modeled with two acrylic-plastic sheets. This technique is advantageous because:

- ceilings are modeled down hand,
- assembly work can progress simultaneously on both a deck and the ceiling beneath, and
- access for obtaining dimensions, e.g., camera access is greatly enhanced.

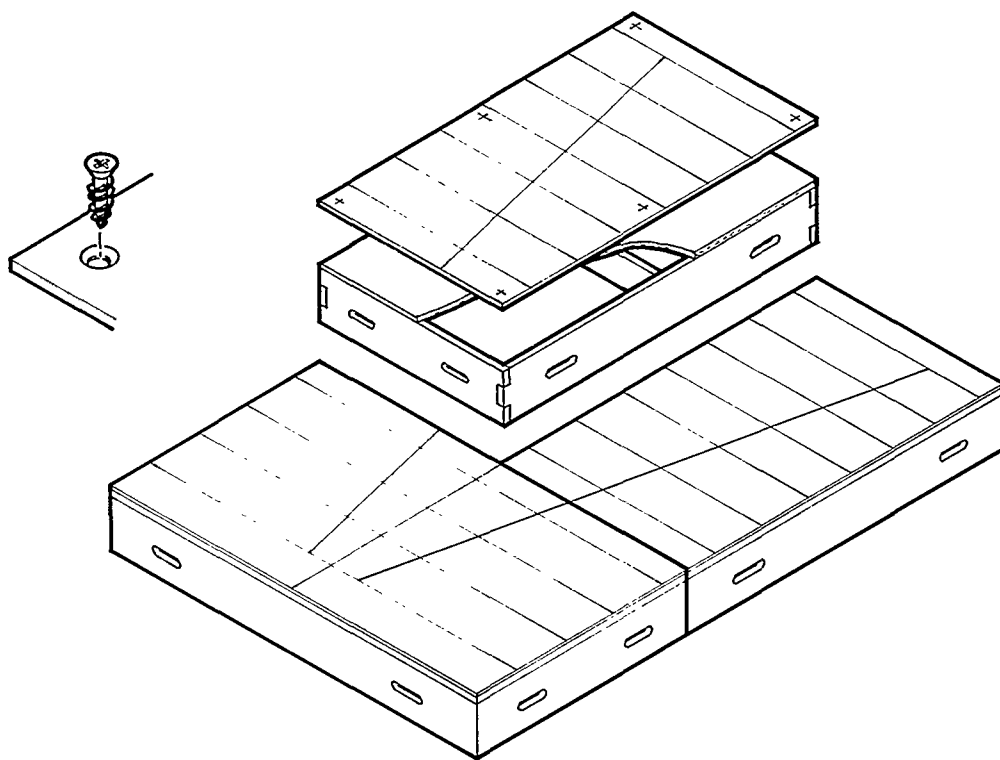
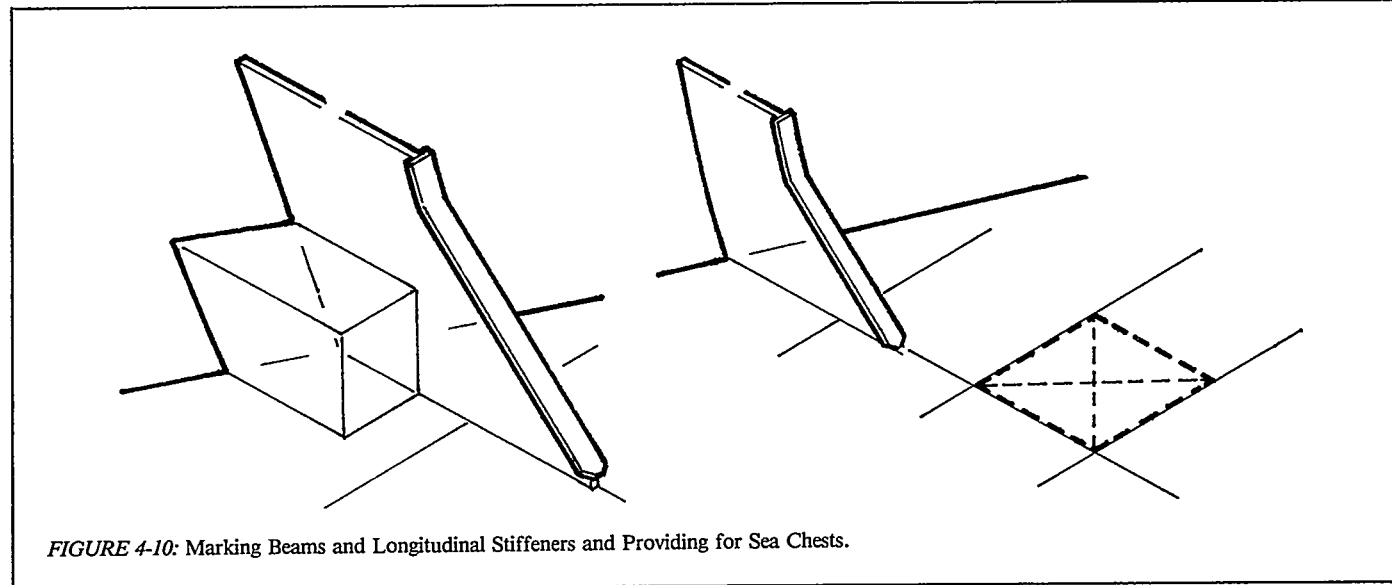
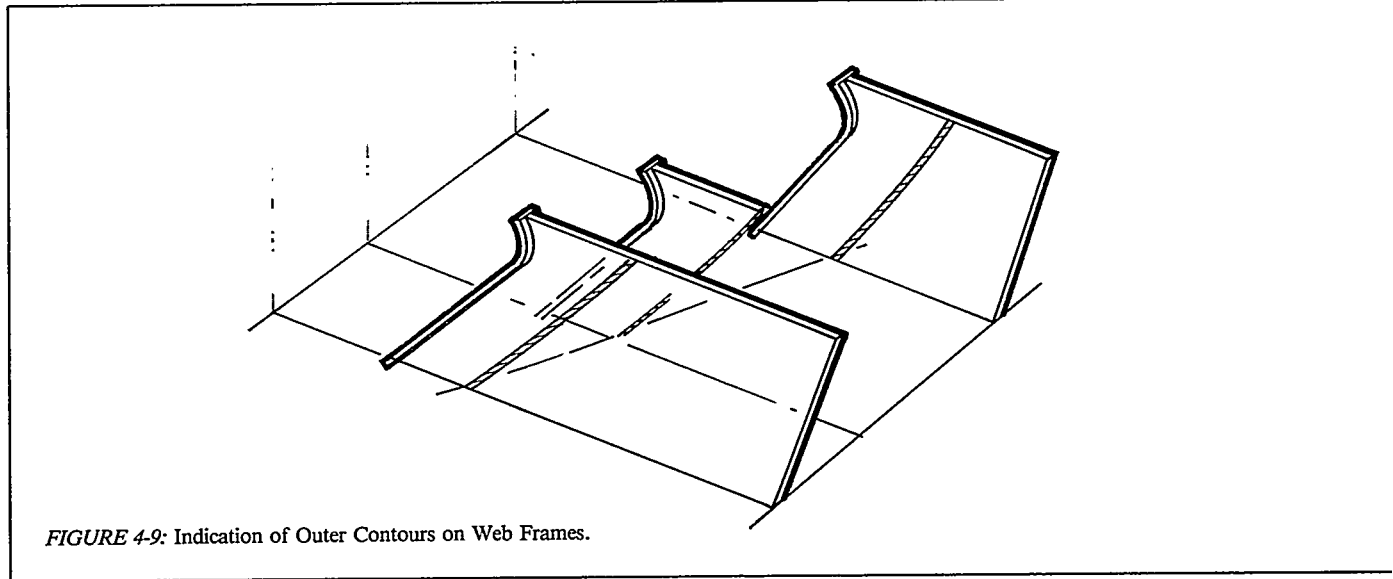
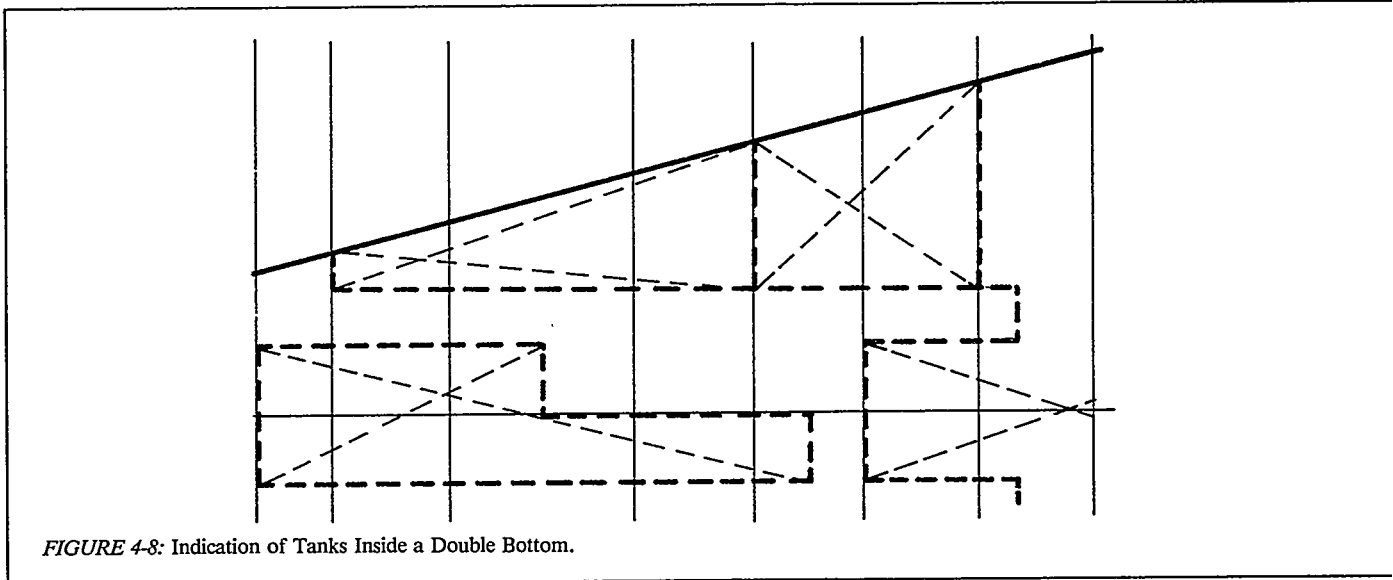

FIGURE 4-7: Model Base in Three Sections.



Regarding an upper deck, camber is not reflected in a model because:

- the effect of camber is represented by the inner curvature of each web frame and its flange, see Figure 4-11, and
- when turned over for modeling a ceiling down hand, each model section representing an upper deck will lie flat.

4.5.6 *Engine Casing*

A number of alternate ways to section an engine casing for modeling are illustrated in Figure 4-12. The sectioning scheme elected should be one that best facilitates the later attachment of modeled fittings.

4.5.7 *Brackets*

Outfitting near brackets can be particularly troublesome as they are frequently omitted from assembly drawings for modeling hull structure. In principle, all brackets should be modeled. The positions of brackets which are not modeled, should be clearly delineated in quick-drying red ink.

4.6 *Web Frame and Column Fabrication and Assembly*

Before any assembly work starts, dimensions of modeled parts and the reference lines incorporated should be checked and, if necessary, marked to show that they have passed inspection.

Figures 4-13 through 4-15 illustrate how model web-frame dimensions are derived from drawings of real structure and how allowances are made for the proportionally thicker model decks. Parts fabrication and various aspects of web-frame assembly are shown in Figures 4-16 through 4-19.

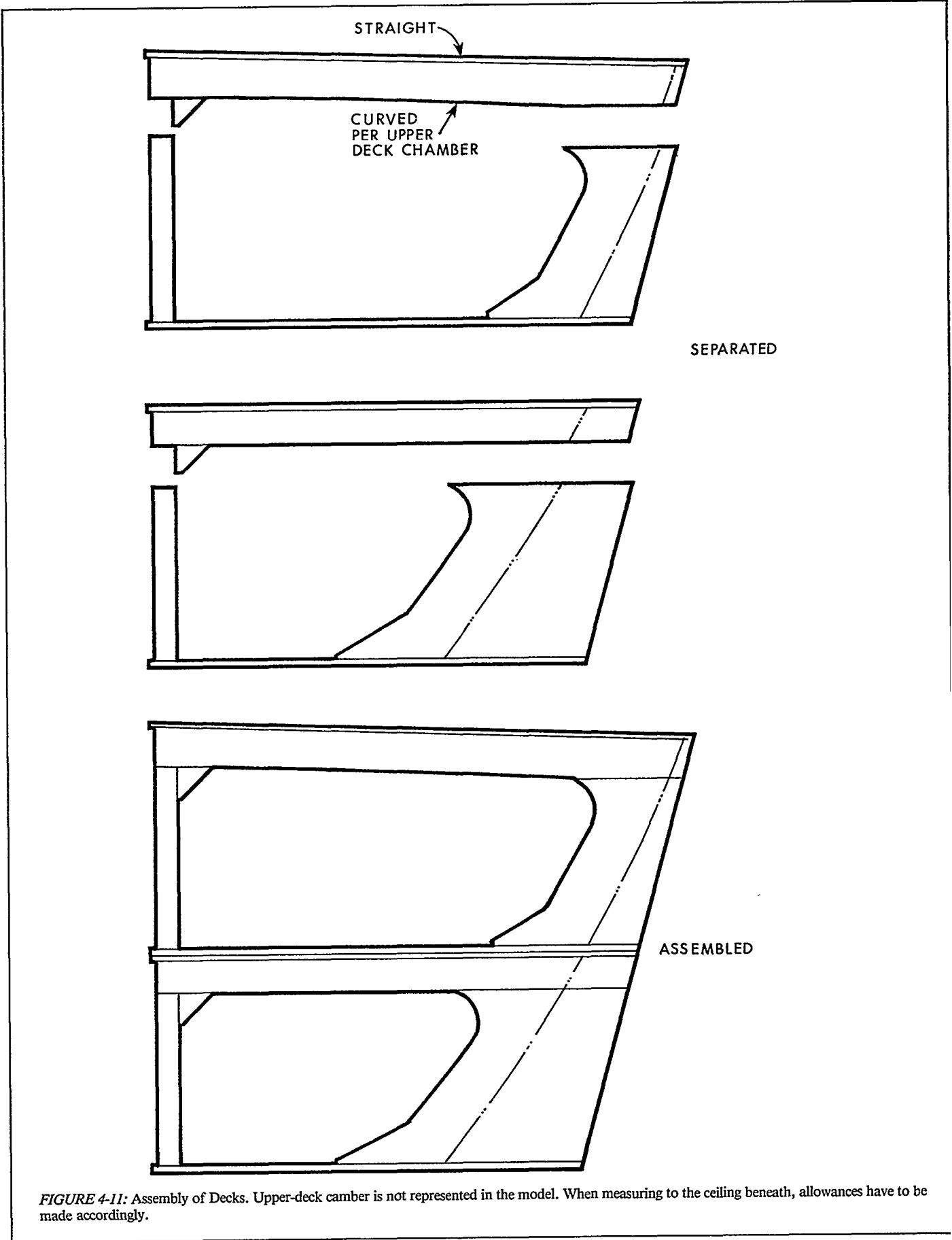
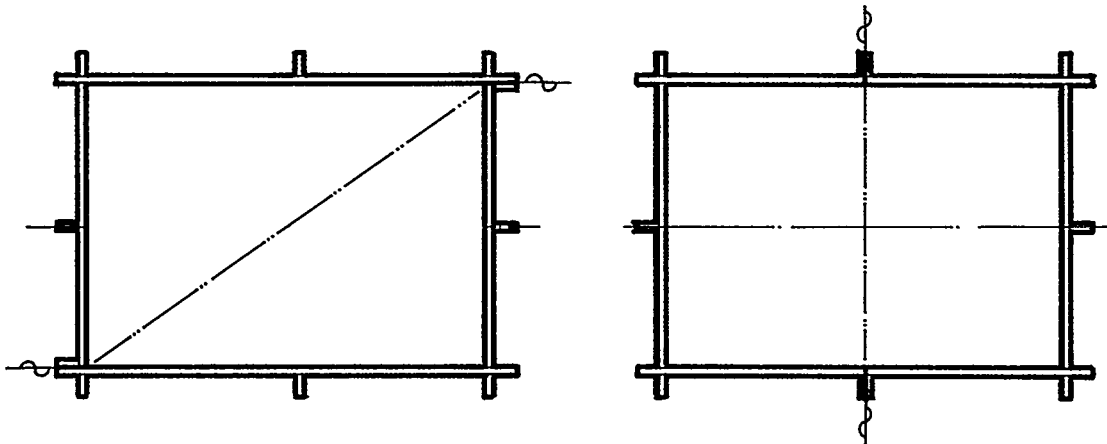
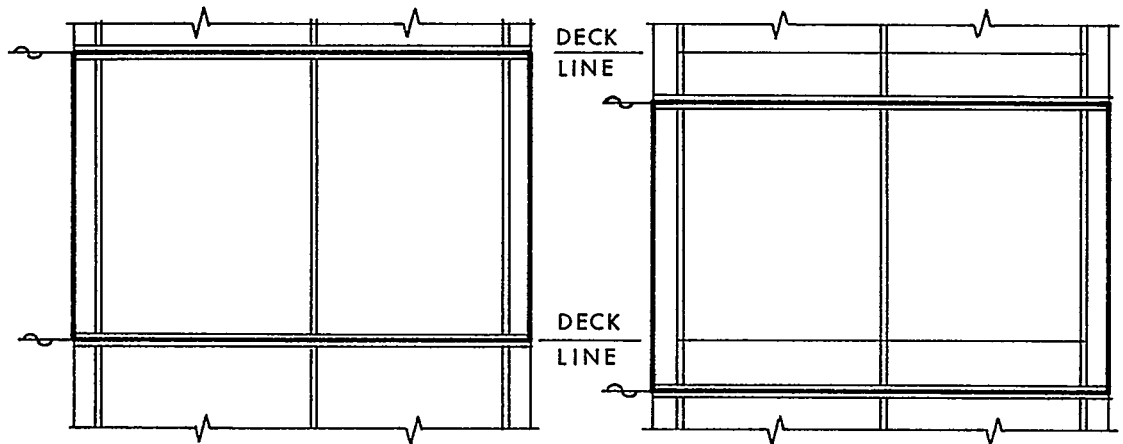
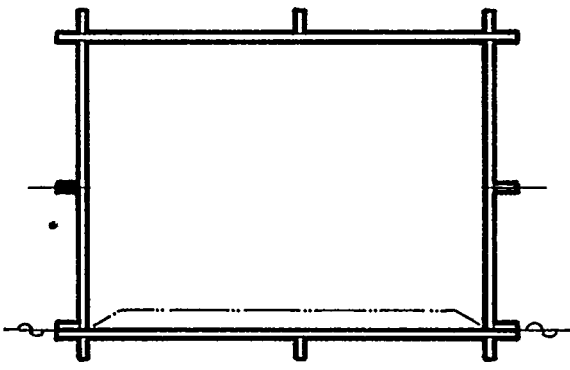

FIGURE 4-11: Assembly of Decks. Upper-deck camber is not represented in the model. When measuring to the ceiling beneath, allowances have to be made accordingly.



PLAN VIEWS



ELEVATIONS

FIGURE 4-12: Alternatives for Dividing an Engine-Room Casing Into Sections.

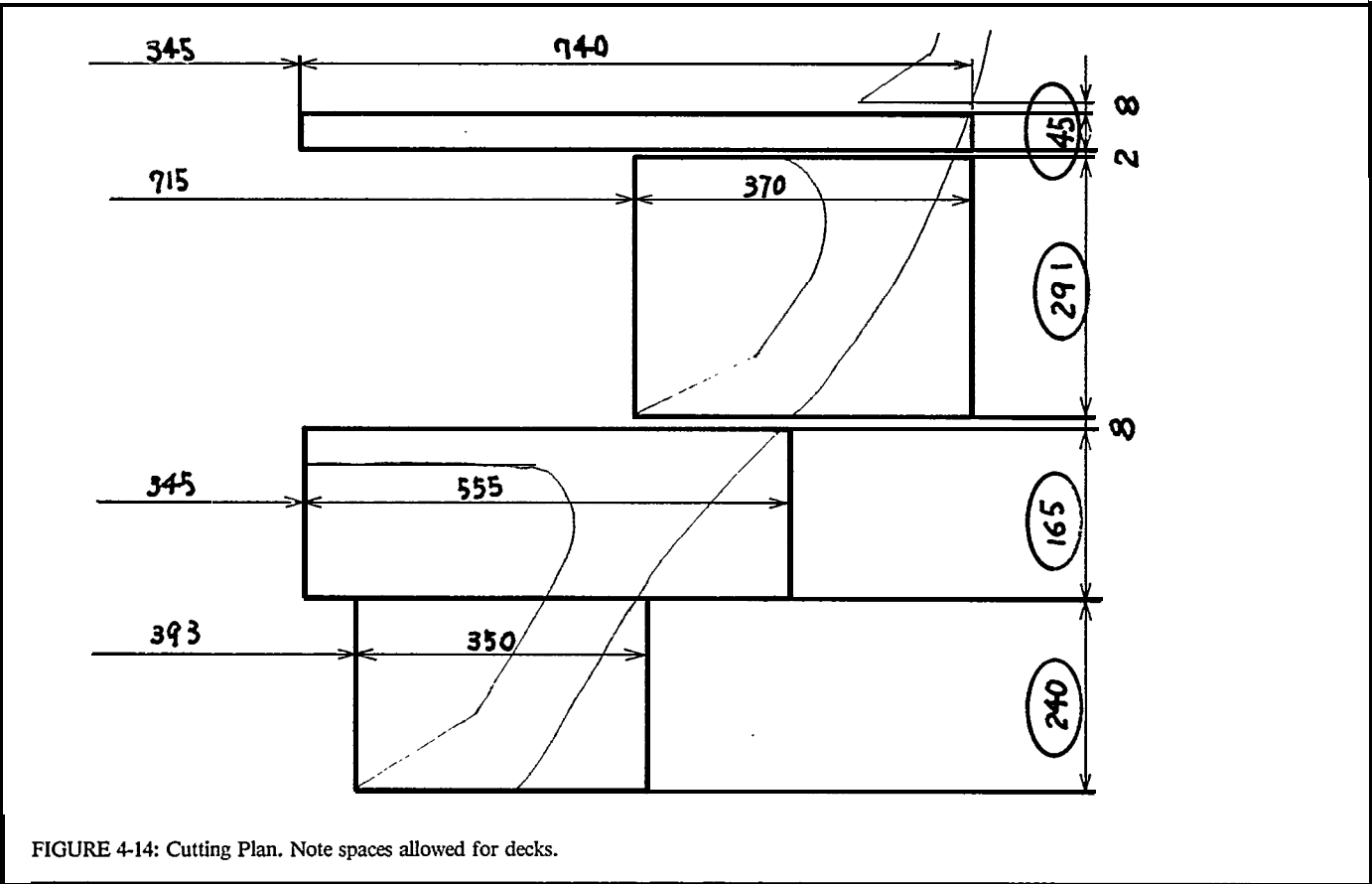

FIGURE 4-14: Cutting Plan. Note spaces allowed for decks.

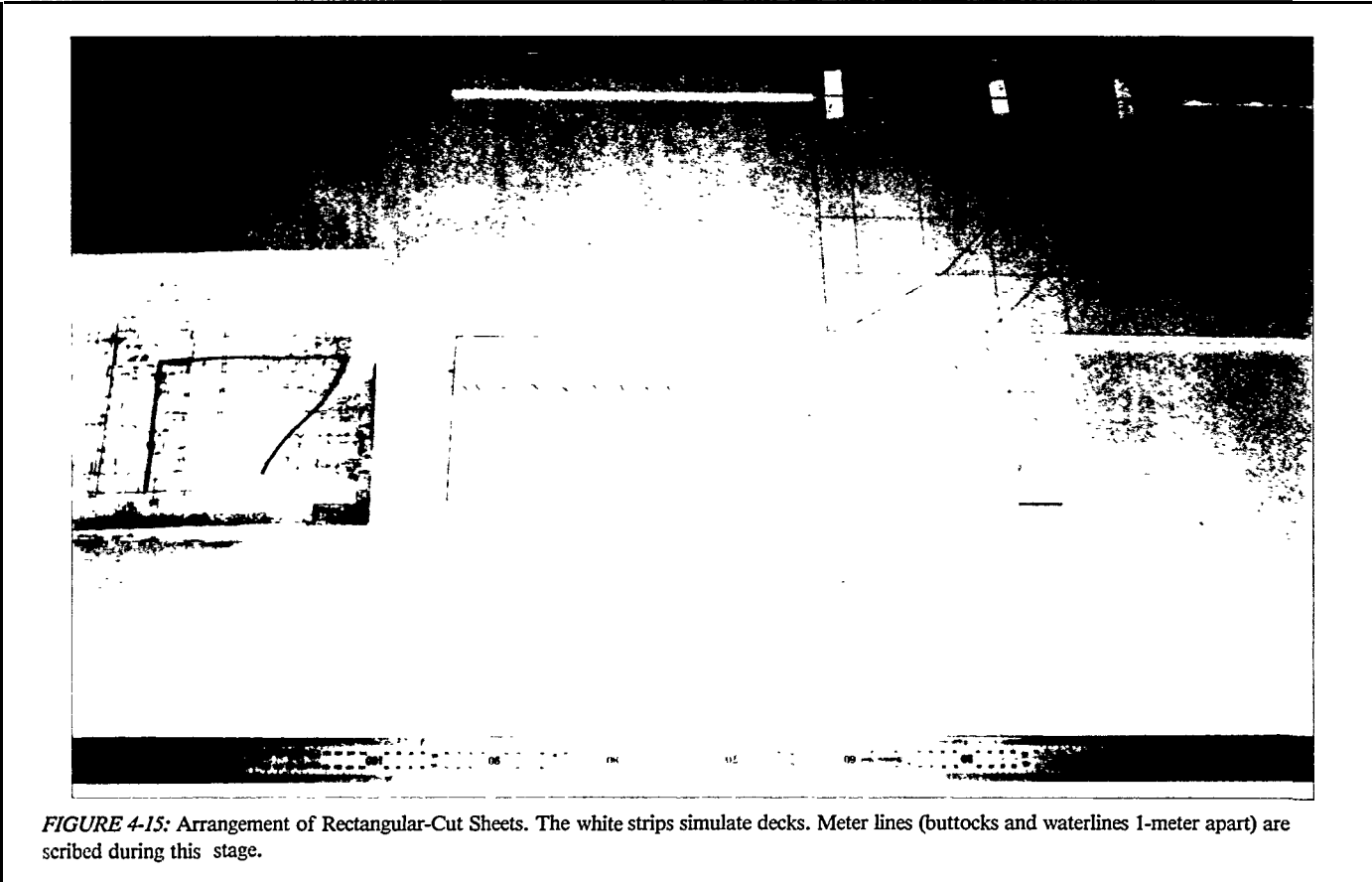

FIGURE 4-15: Arrangement of Rectangular-Cut Sheets. The white strips simulate decks. Meter lines (buttocks and waterlines 1-meter apart) are scribed during this stage.

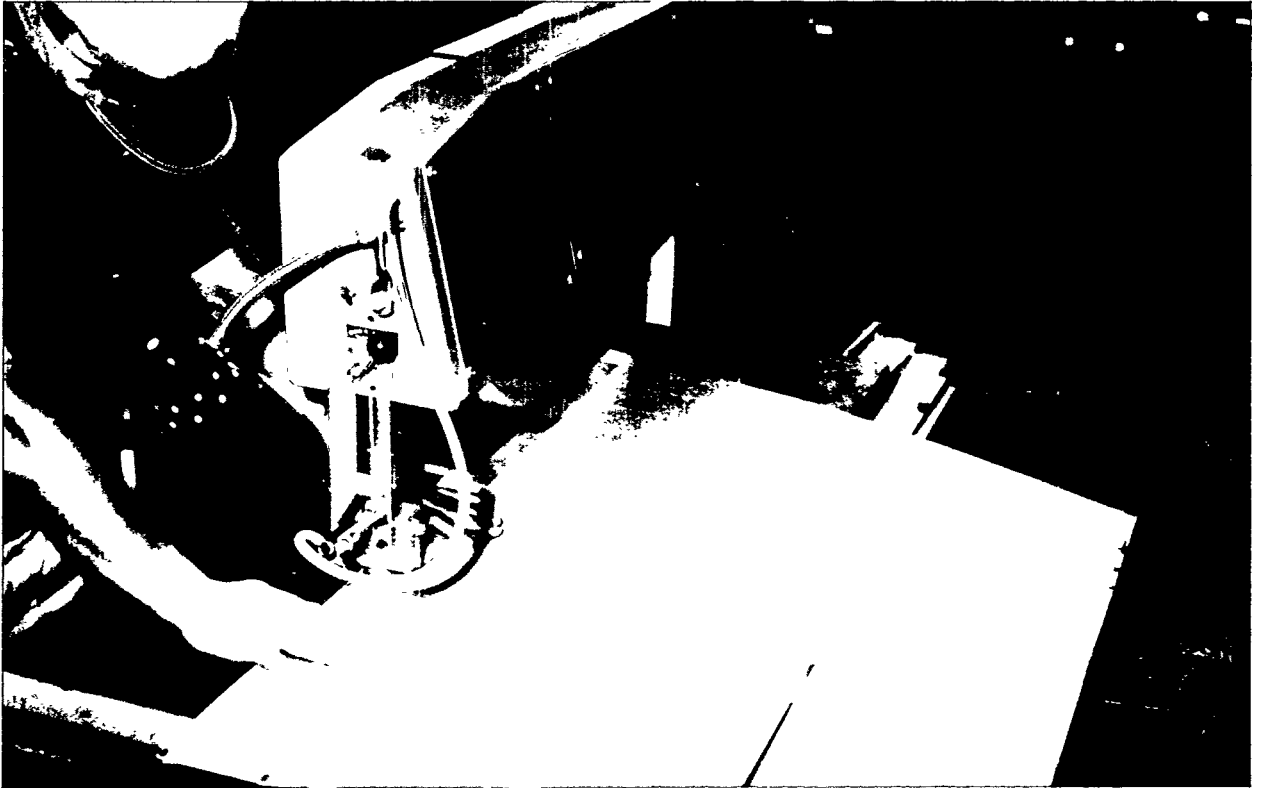

FIGURE 4-16: Band-Saw Cutting Finishing is performed with sandpaper or a file to insure good joints for bonding



FIGURE 4-17: Attaching a Web Frame to a Deck Each web is carefully positioned relative to a reference line A syringe facilitates metering the right amount of adhesive and a square is used for alignment

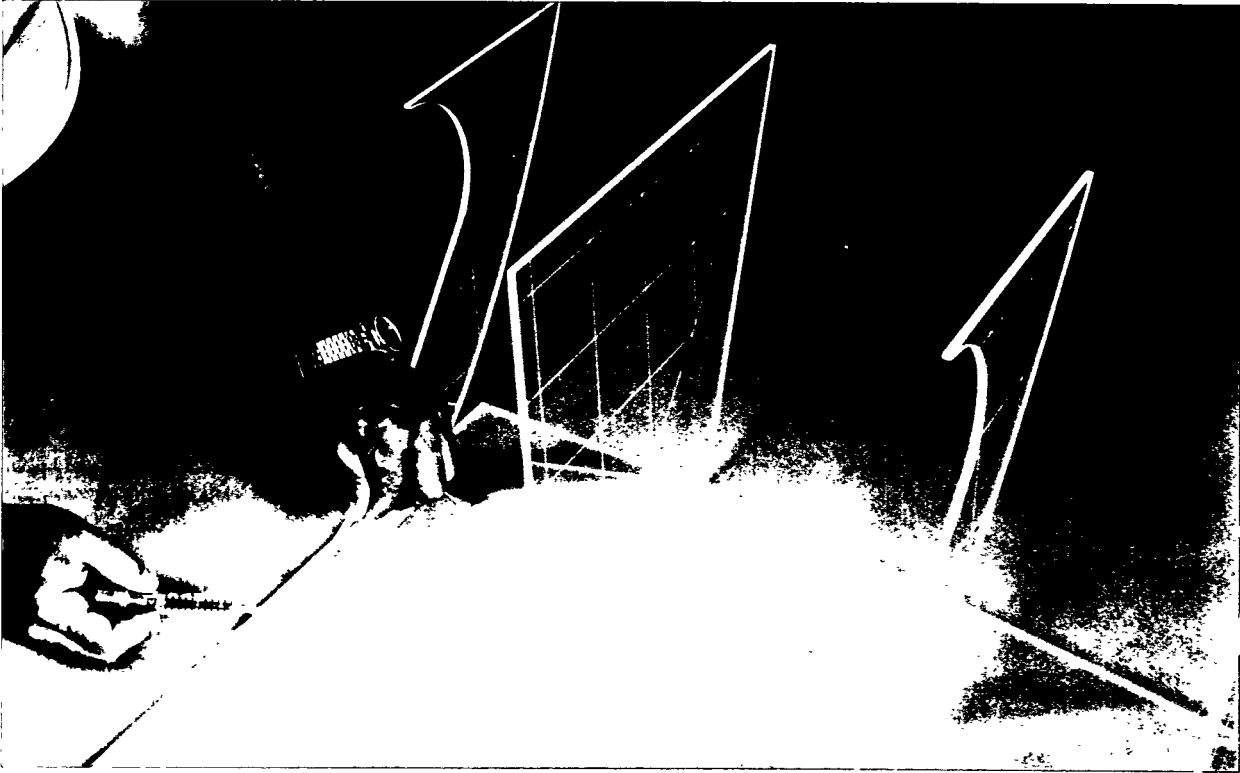

FIGURE 4-18: Attaching a Faceplate to a Web Frame. For small-radius curvatures, faceplates are heated to facilitate bending.

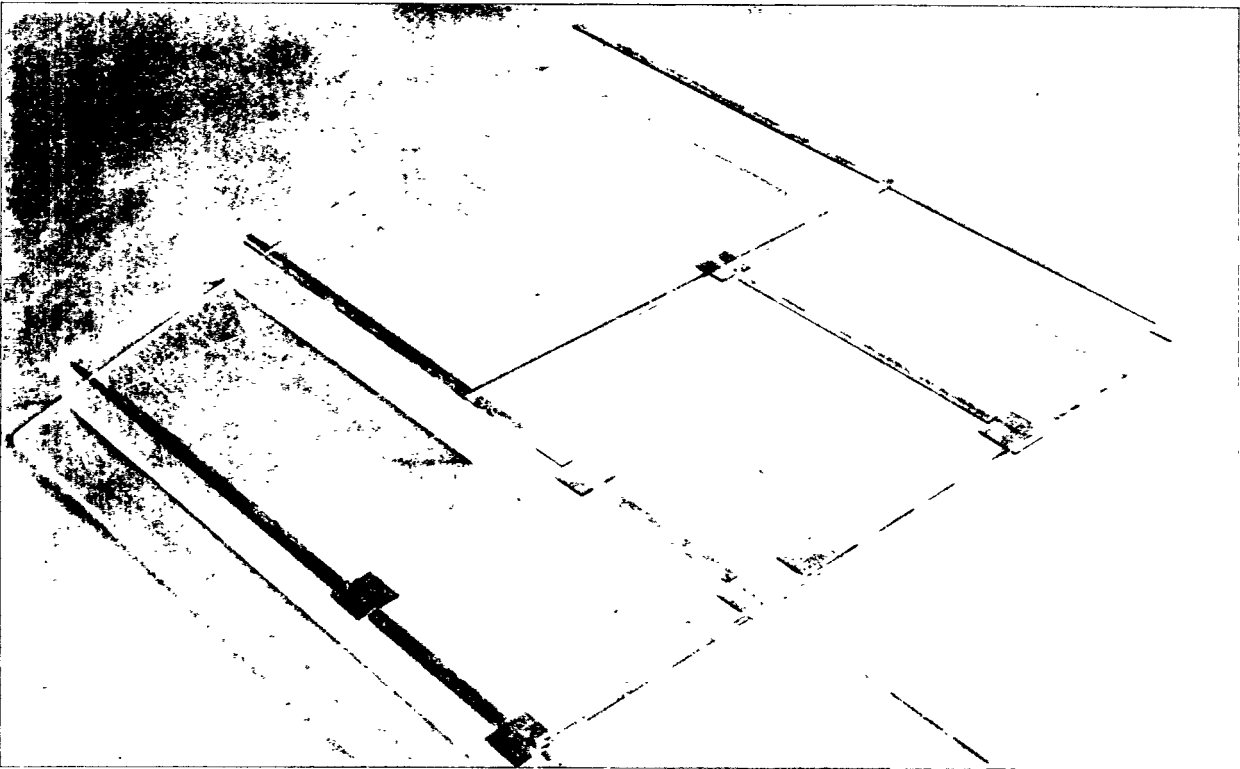

FIGURE 4-19: Completed Underside of a Deck.

Model columns are made as shown in Figure 4-20 with reliance on jigs and in lengths dependent upon available materials. Afterwards, they are cut to required lengths. Figure 4-21 shows a column on a tank top and a web frame divided at approximately mid height between the tank top and third deck. Such divisions should match those planned for erection of an actual hull. Having such butts and seams well above the tank top insures that access for erection welding is not confined by machinery, piping and other components fitted on-block.

On higher levels, columns and web frames are divided near the ceilings as shown for the 3rd and 2nd decks in Figure 4-21. This feature facilitates disassembly and reassembly of model sections but is not likely to match the divisions preferred for actual hull erection which are shown in Figure 4-22.

Model web-frames and columns should be carefully aligned during assembly as depicted in Figure 4-23.

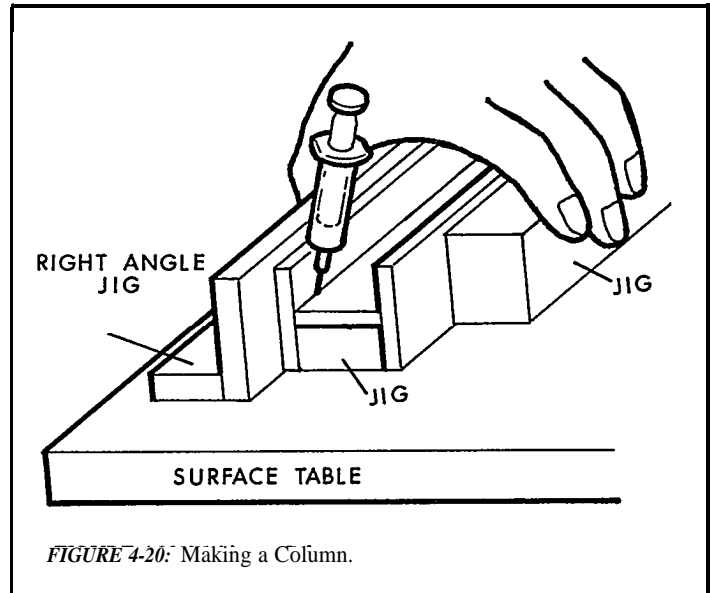

FIGURE 4-20: Making a Column.

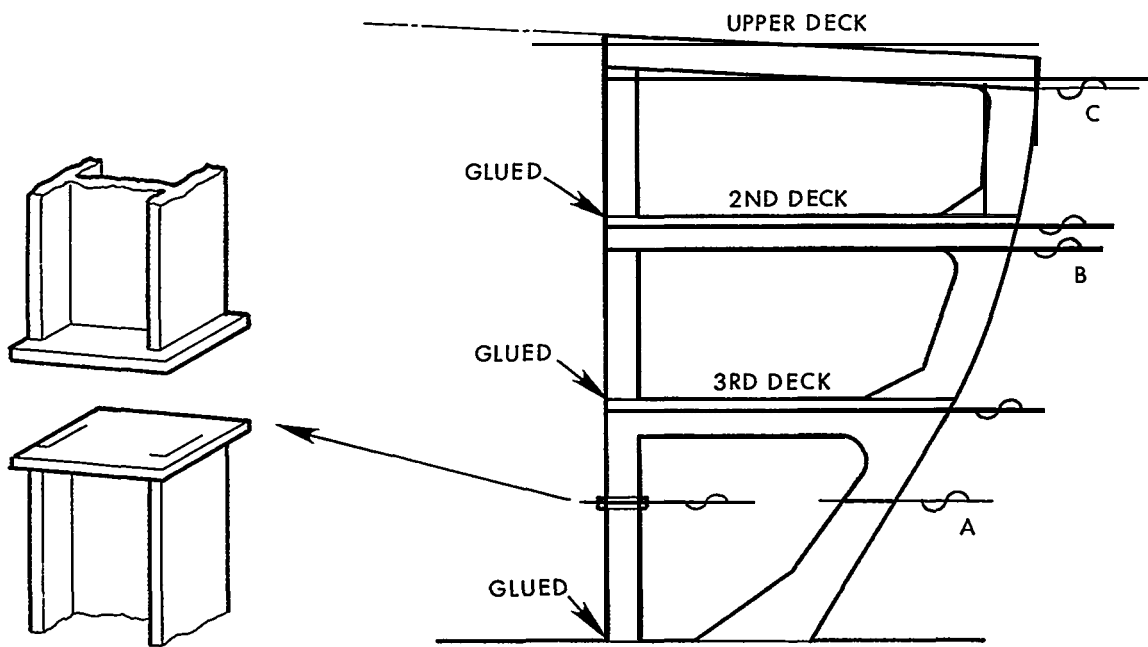

FIGURE 4-21: Attaching Columns. The division shown at A corresponds to that for erection of the actual hull. The divisions at B and C are only to facilitate assembly and disassembly of the model.

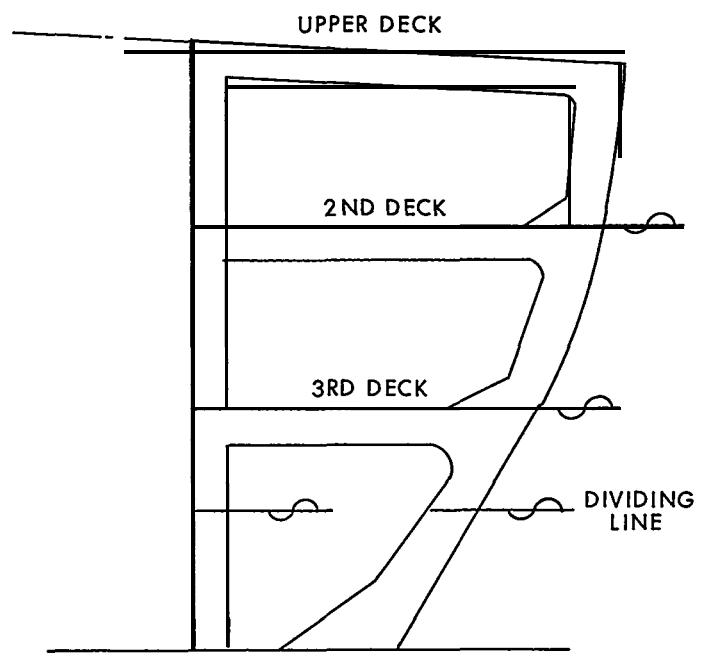

FIGURE 4-22: Hull Block Definition for an Actual Hull. Except for the block incorporating the tank top, blocks are defined so that they are stable when upside down for outfitting on ceilings and also when turned over for outfitting on decks. Further, such stability minimizes the need for stays and shores during the erection process.

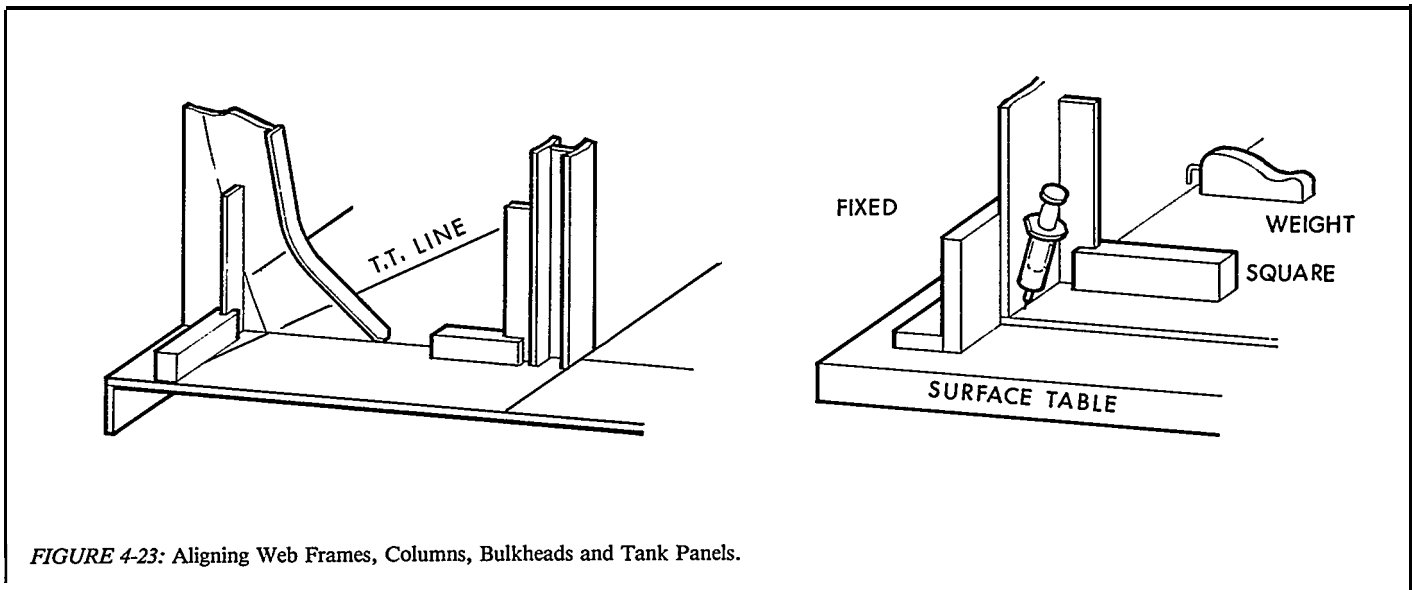

FIGURE 4-23: Aligning Web Frames, Columns, Bulkheads and Tank Panels.

4.7 Connecting and Fastening Model Hull Sections

Before completely assembled hull sections are joined together to form a hull model, each section should be inspected for proper:

- horizontal and vertical alignment,
- overall dimensions,
- dimensions between web frames and their heights, and
- dimensions between reference lines.

During initial assembly of hull sections, various guides are employed to align webs and decks and C-clamps are temporarily employed until final alignment is achieved all over; see Figure 4-24. Afterwards holes are drilled to accommodate bolts. Wing nuts are employed to facilitate disassembly and reassembly as when there is need to implement design changes.

4.8 Adhesives

Two kinds of adhesives are generally employed for assembling modeled hull structure:

- Alphacyanoacrylate:

- is an instant adhesive suitable for temporary adhesion only,
- is adversely affected by climatic circumstances, particularly ultraviolet light and
- hardens in a moment when used with a hardening-quickener which if not carefully applied can cause burns to a modeler's hands.

- Dichloromethane (CH_2Cl_2):

- is not an instant adhesive but will achieve strong long-term adhesion,
- will, when too much is applied, dissolve plastic parts,
- will, when splattered, make unsightly specks, and
- is cheap and seems most suitable.

Any adhesive should be applied with a syringe having a barrel and fitted with a plunger and hollow needle in order to meter required amounts.

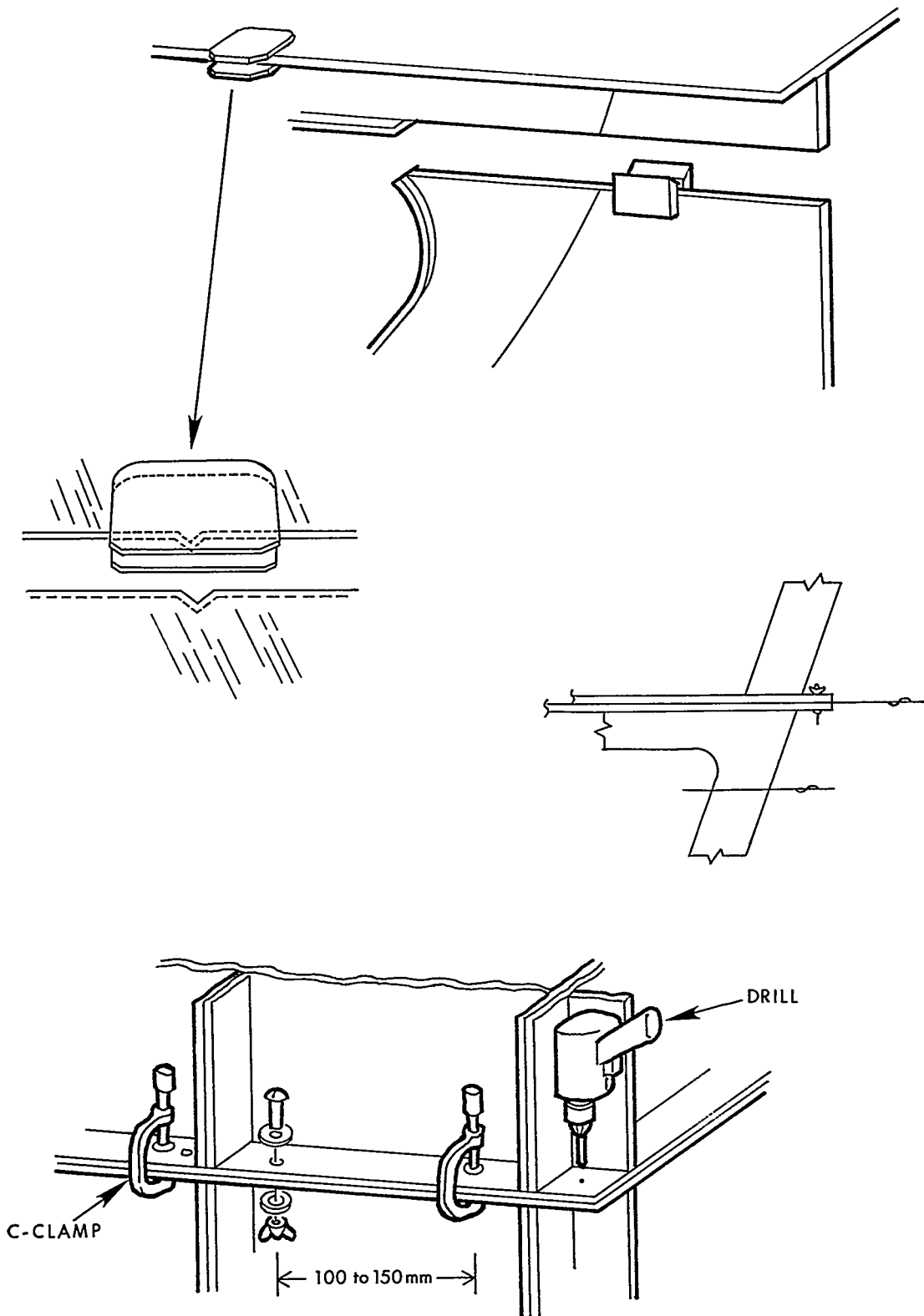

FIGURE 4-24: Connecting and Fastening Hull-model Sections. Bolt-hole diameters are 0.5 millimeter larger than bolt diameters.

4.9 Miscellaneous Items

Simple ways of representing miscellaneous items often included in design models, are illustrated in Figures 4-25 through 4-27.

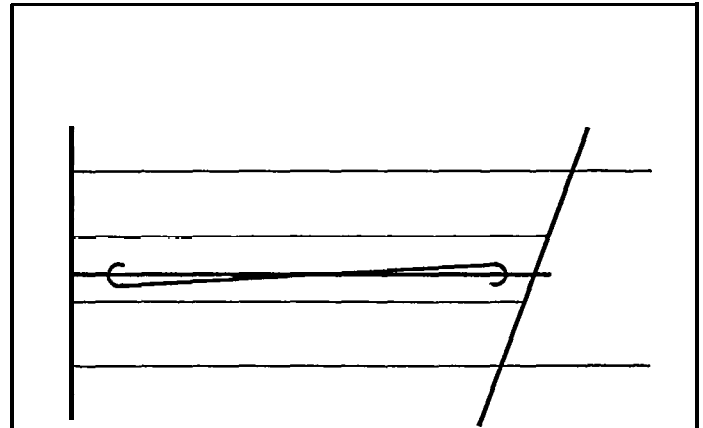

FIGURE 4-25: Marking Block Seams and Butts. Quick-drying black ink is used.

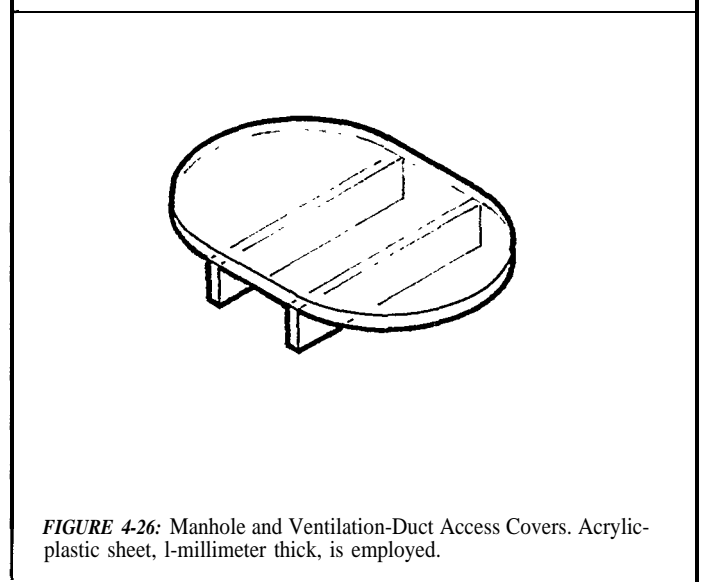

FIGURE 4-26: Manhole and Ventilation-Duct Access Covers. Acrylic-plastic sheet, 1-millimeter thick, is employed.

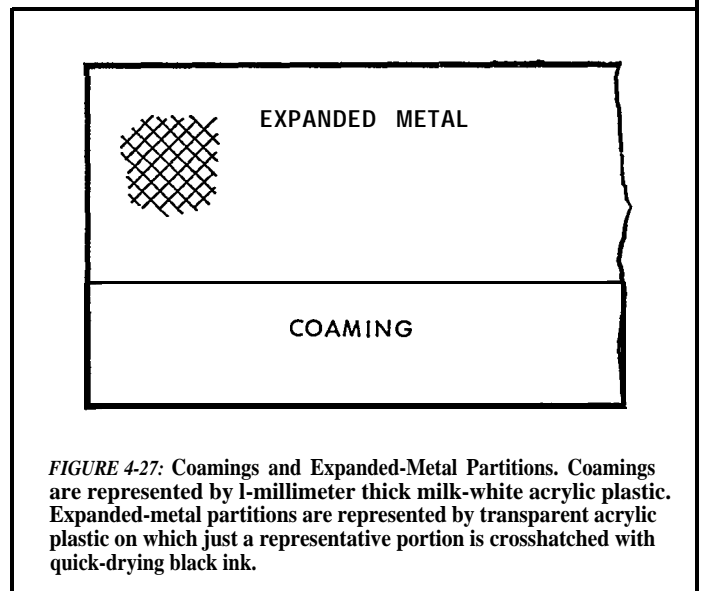

FIGURE 4-27: Coamings and Expanded-Metal Partitions. Coamings are represented by 1-millimeter thick milk-white acrylic plastic. Expanded-metal partitions are represented by transparent acrylic plastic on which just a representative portion is crosshatched with quick-drying black ink.

5.0 MODELING MACHINERY

5.1 General

Very accurate modeling of machinery is expensive. When roughly made, models of machines are cheaper and not very impressive in appearance. Thus, the degree of accuracy to be achieved depends on the purposes of a design model.

Necessary prerequisites for models of machinery needed for a typical engine room are:

- realism sufficient for fixing certain design features,
- enough strength to prevent bending under the weight of modeled piping and steel work,
- light weight to facilitate transportation, and
- designed so as to facilitate attachment of pipes and other fittings.

5.2 Machinery Items

There are many different machinery items arranged in typical engine-rooms. Although some are standardized, most are different from each other. Typical machinery includes:

- diesel, gas-turbine and steam-turbine propulsion engines,
- generators,
- main and auxiliary boilers,
- oil purifiers,
- cargo-pump turbines,
- desalinators,
- pumps,
- heat exchangers,
- air compressors,
- tanks,
- chillers,
- motor controllers,
- switchboards, etc.

5.3 Materials and Colors

5.3.1 Material

Standard machinery items available from model-supply firms should be used as much as possible. Non-standard items are usually made from ABS resin and acrylic-plastic sheets, bars, etc. as these materials are suitable for working, adhering and painting. Plastic sheets of 2-millimeters and less in thickness are preferred because of ease in cutting, forming and finishing. Dichloromethane is the adhesive recommended for such work. Other materials, e.g., plastic foam and wood, impose problems relating to adhesion, weight, painting, dust collection, etc.

5.3.2 Strength

Small-size model components tend to be fragile unless special measures are applied:

- modeled items are made as light as possible to prevent breakage during accidental falls,
- joints should be designed so that surfaces to be adhered are as large as possible; see Figure 5-1, and
- extraneous attachments, insofar as they do not define key interfaces, such as a pipe nozzle, are omitted.

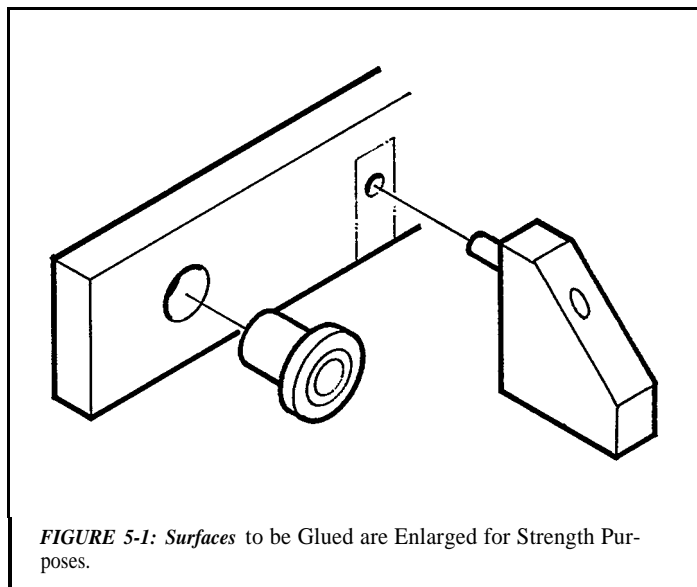

5.3.3 *Colors*

Spray painting is preferred over brush painting for both finish and workability. Color schemes for machinery items are not usually significant. In special cases, the same color scheme is used for modeled machinery as an owner employs in real ships. Other times, a shipyard's standard color scheme for a real engine room is employed. In most cases, light-green is used for all modeled machinery.

5.4 *Accuracy*

The overall size and shape of a modeled machine should be a sufficient, not perfect, representation of its real counterpart. In 1:15 scale, the tolerance for dimensions which fix nozzle positions should be plus or minus 1 millimeter which corresponds to plus or minus 15 millimeters in a real engine-room. However, when such accuracy cannot be maintained during modeling, dimensions extracted from a finished design-model will require adjustment before the preparation of fabrication and assembly work-instructions.

5.5 *How to Model Machinery*

5.5.1 *Shape*

In general, machinery models should be simple so that they just fulfill specific design-modeling needs. There are usually no requirements to reproduce many machinery details. Simplification results in easier work and lower costs. However, for training or display purposes some owners may require more detail than is required for design modeling. In any case, dimensions which fix certain features, e.g., pipe and electric-cable connections and space reserved for maintenance, should be faithfully incorporated.

Some principles which generally apply are:

- dimensions which fix pipe connections shall be accurate,
- complicated shapes should be reduced to simple, or combinations of simple, geometric forms, i.e., cubes, cylinders, etc.
- irregular machinery surfaces should not be represented, and
- attached pipes provided by machinery manufacturers should be represented with precise definition of where they will connect to shipbuilder-responsible pipe runs.

5.5.2 *Cylinders, Cones and Cubes*

Cylinders preferably of ABS resin, are usually cut to length from tubing. Discs cut from sheet plastic are fitted to the ends. Sometimes, when diameters are relatively small, cylinders are shaped on a lathe from round stock. Similarly, ***cones are also*** shaped on a lathe. ***Cubes are*** made from acrylic-plastic sheet, preferably 2-millimeters thick. Usually, remnants that result from constructing a hull model are employed.

5.5.3 *Machinery Models*

Various examples for modeling machinery are illustrated in Figures 5-2 through 5-12. Particular note is made of Figures 5-2 and 5-3 which show simplified models sufficient for design modeling compared to more complex versions as needed for operation training or for display purposes.

5.5.4 *Other Matters*

Centerlines and baselines are required on models of machinery items in order to:

- **confirm positions and dimensions of nozzles,**
- **accurately locate positions of machinery models, and**
- **obtain dimensions required for other fitting work**

Terminal box positions, except for very small motors, should be clearly defined. A large terminal box should be faithfully modeled and attached to its motor. Models for small terminal boxes could be simply represented by noting their positions on motors with quick-drying ink.

Modeled machinery items should bear identifications. Usually, actual names or code numbers from layout drawings are printed on adhesive labels which are fixed to easily seen parts of modeled machinery.

Similarly, the direction of flow in each pipe system is marked in design models. Extreme care must be taken, as incorrect identification of flows could have serious consequences, such as pressure on top of a valve disc.

Adhesive labels are used to identify space reservations for maintenance, such as for heat exchangers. Manholes and test holes are also identified in this manner.

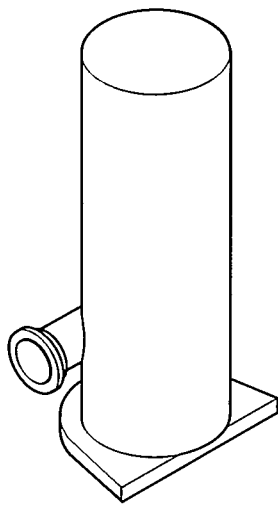

A

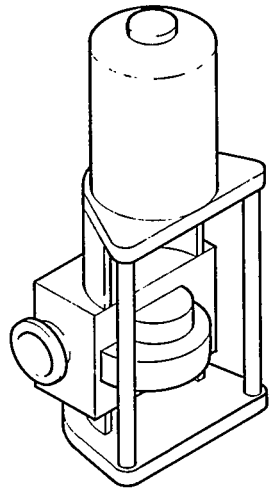
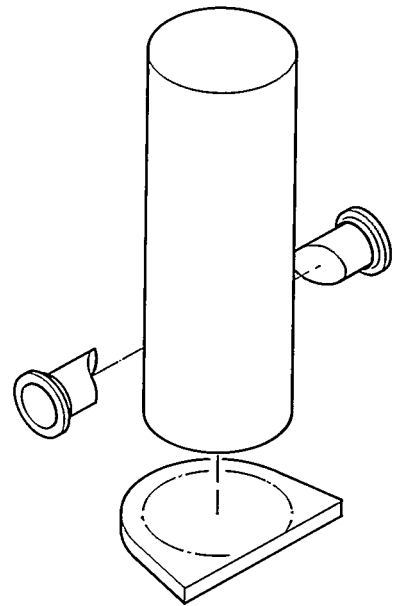

B

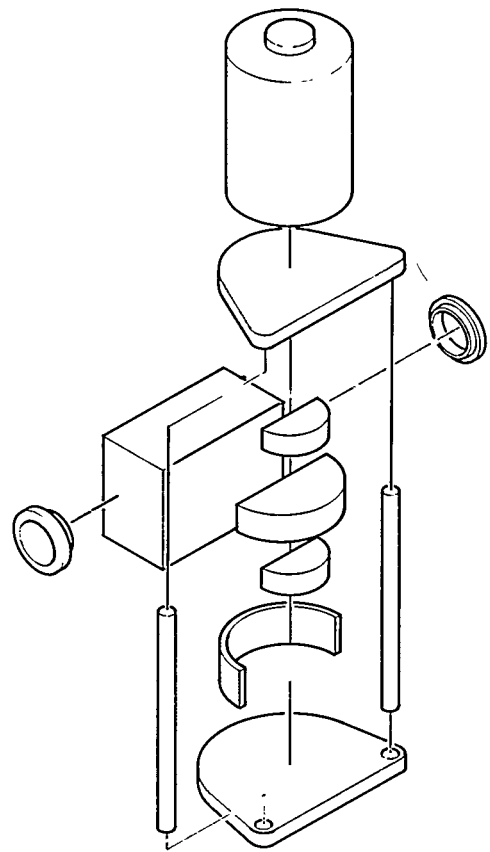

FIGURE 5-2: Modeling a Vertical Pump. The simple version, A, is sufficient for design modeling. Training or display requirements could require more detail, B.

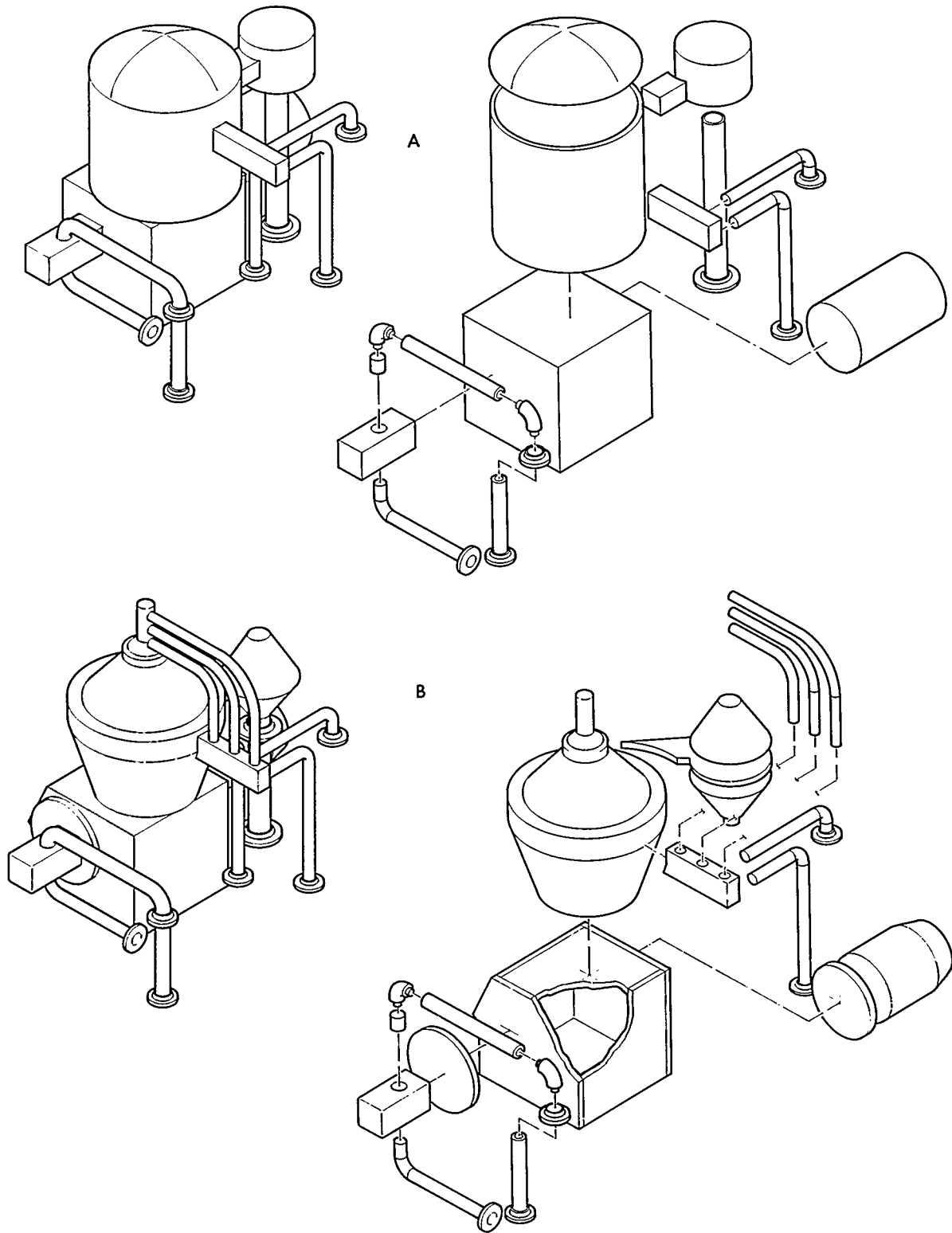
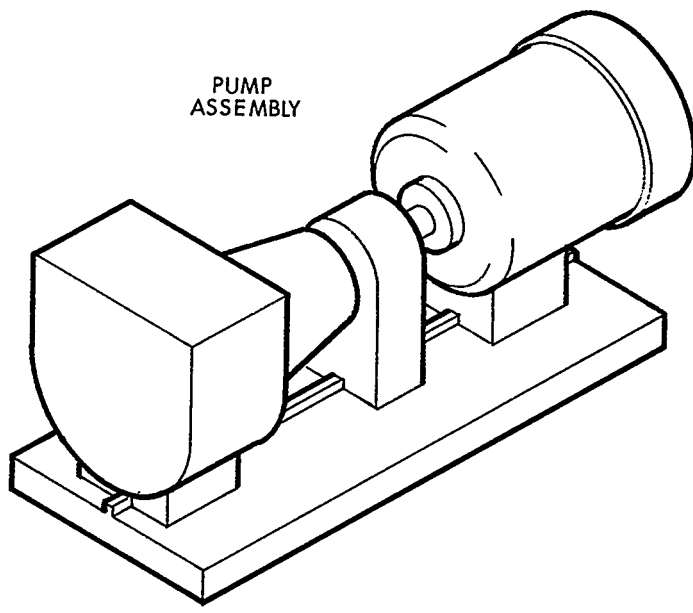
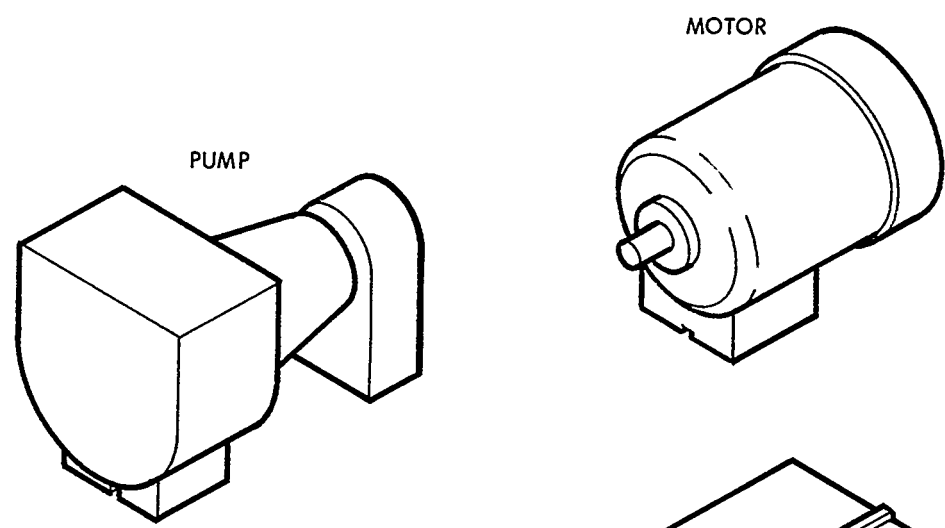

FIGURE 5-3: Modeling a Lube-Oil Purifier. The simple version, A, is sufficient for design modeling. Training or display requirements could require more detail, B.



PUMP
ASSEMBLY



PUMP

MOTOR

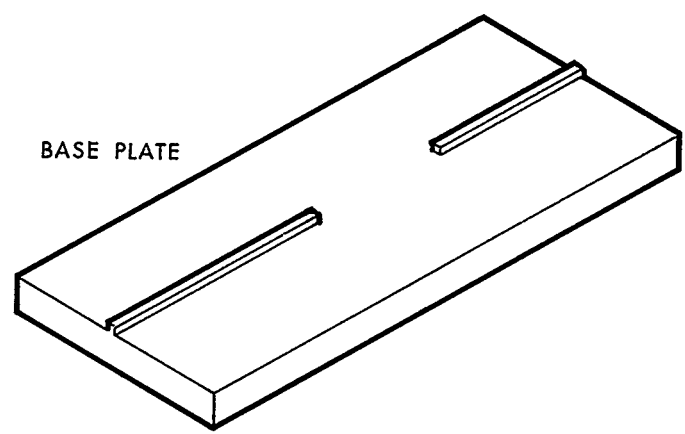

BASE PLATE

FIGURE 5-4: Horizontal Electric-Drive Pump.

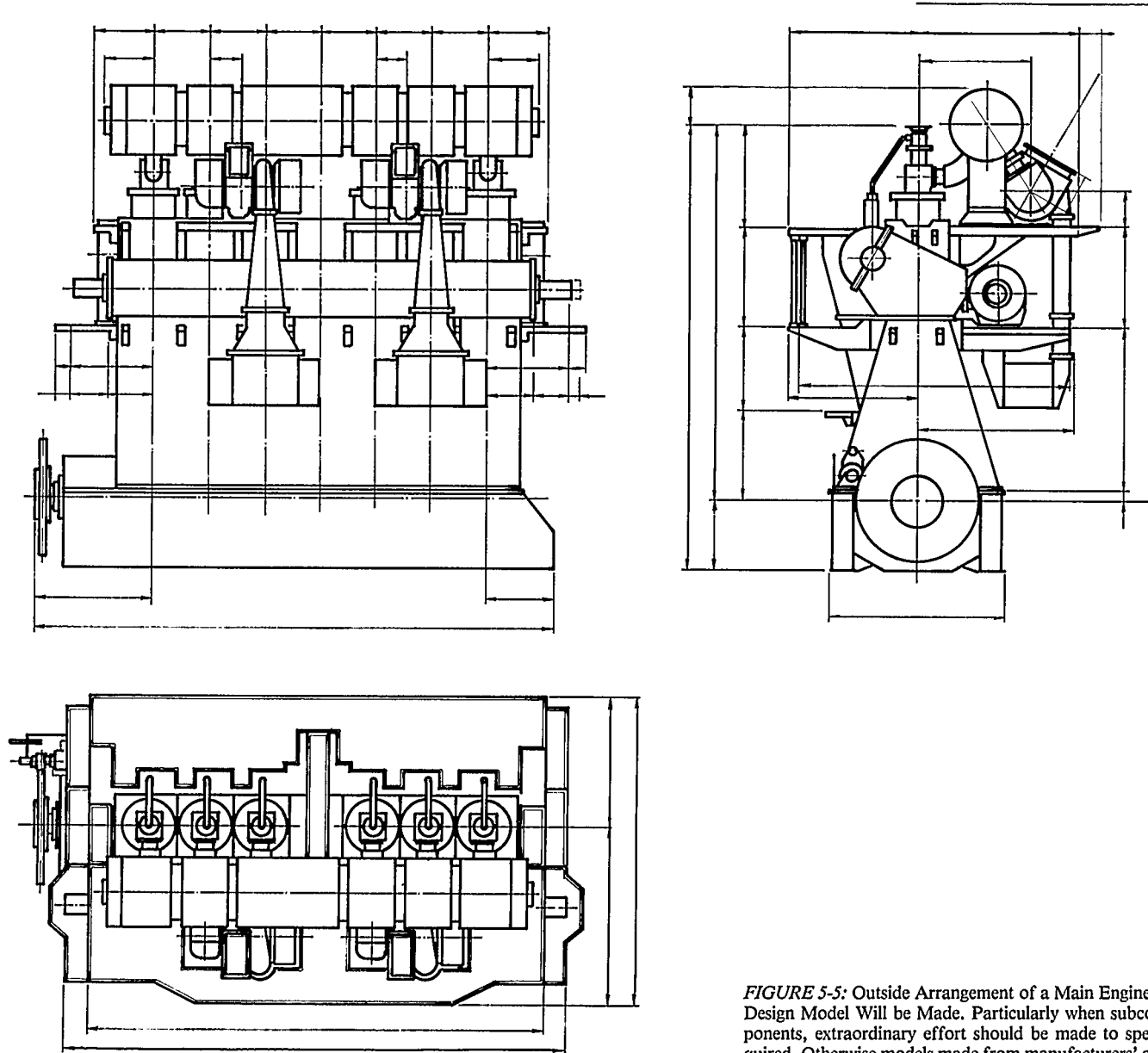

FIGURE 5-5: Outside Arrangement of a Main Engine From Which a Simplified Design Model Will be Made. Particularly when subcontracting for model components, extraordinary effort should be made to specify the level of detail required. Otherwise models made from manufacturers' arrangements, such as for a main engine, could be unnecessarily expensive.

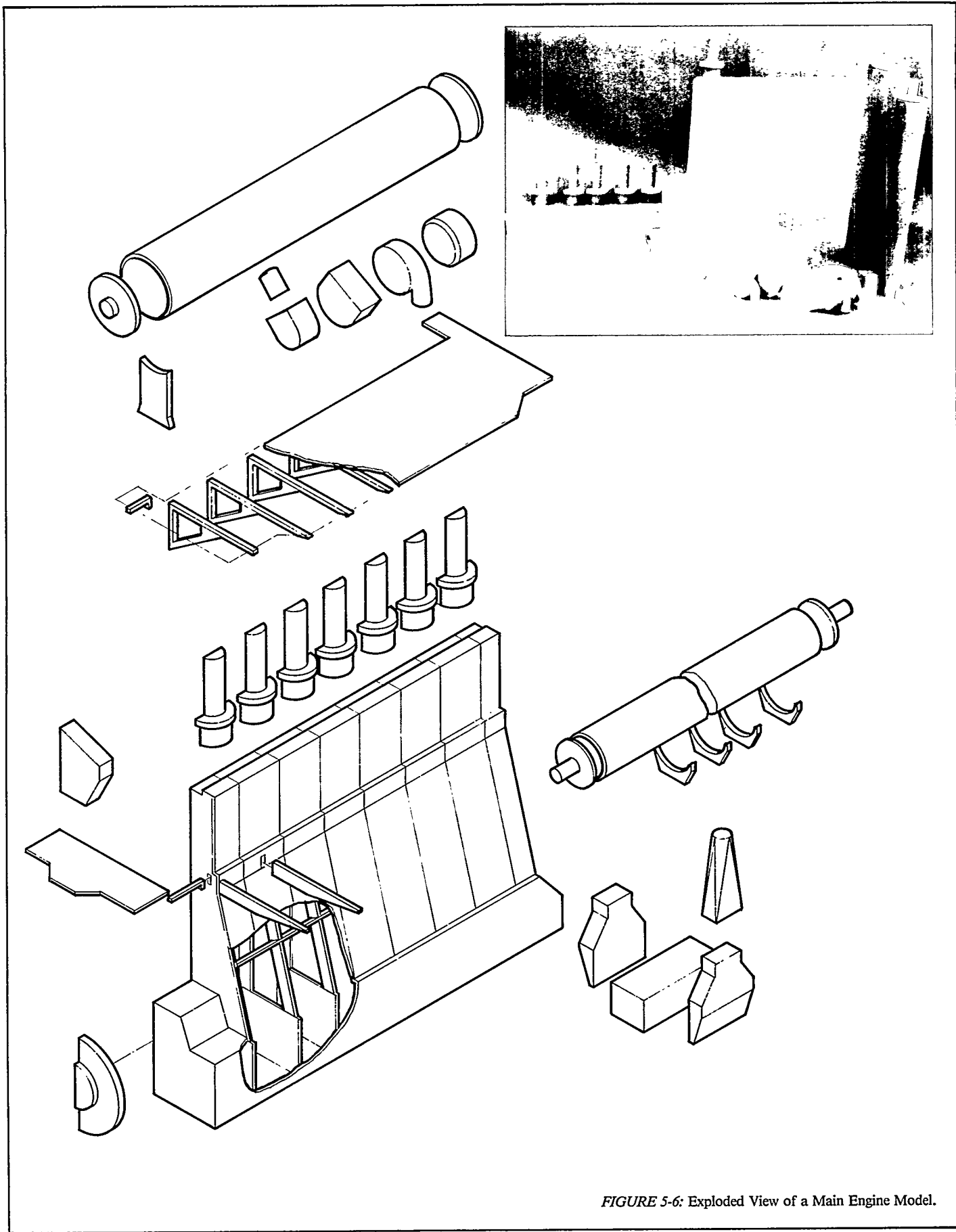

FIGURE 5-6: Exploded View of a Main Engine Model.

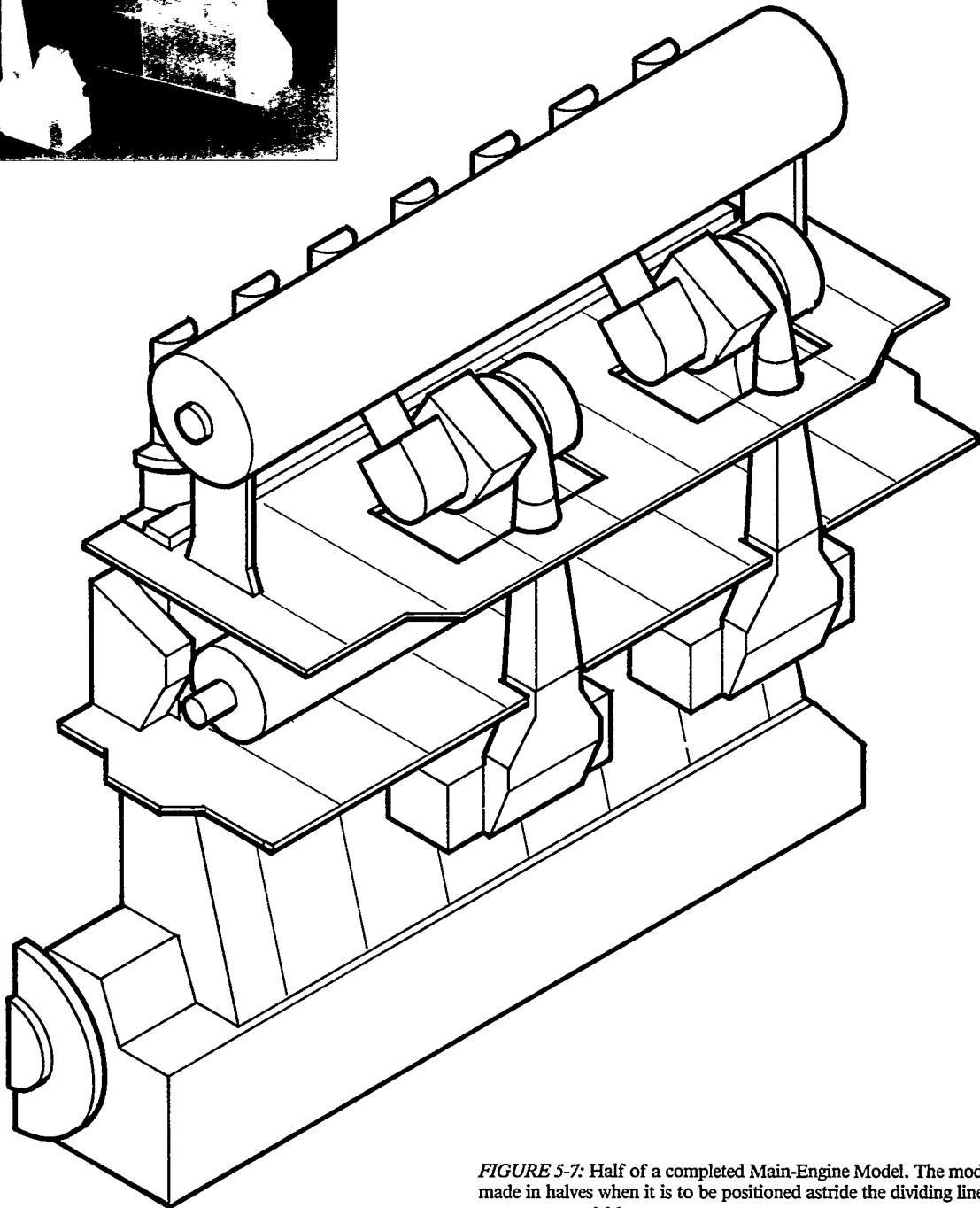
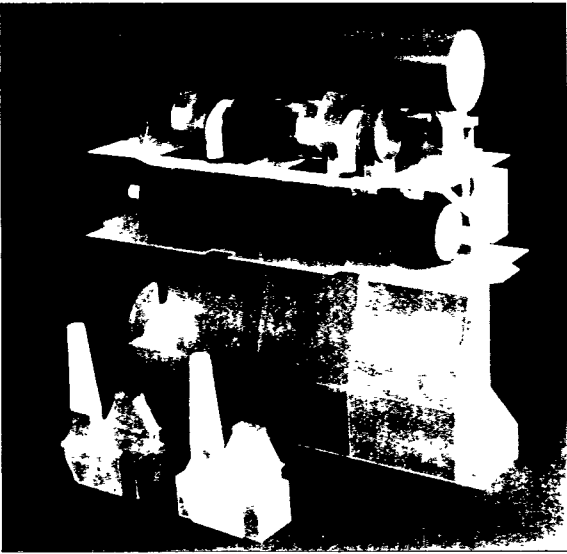

FIGURE 5-7: Half of a completed Main-Engine Model. The model is made in halves when it is to be positioned astride the dividing line between two model bases.



FIGURE 5-8: Air-Compressor Models.

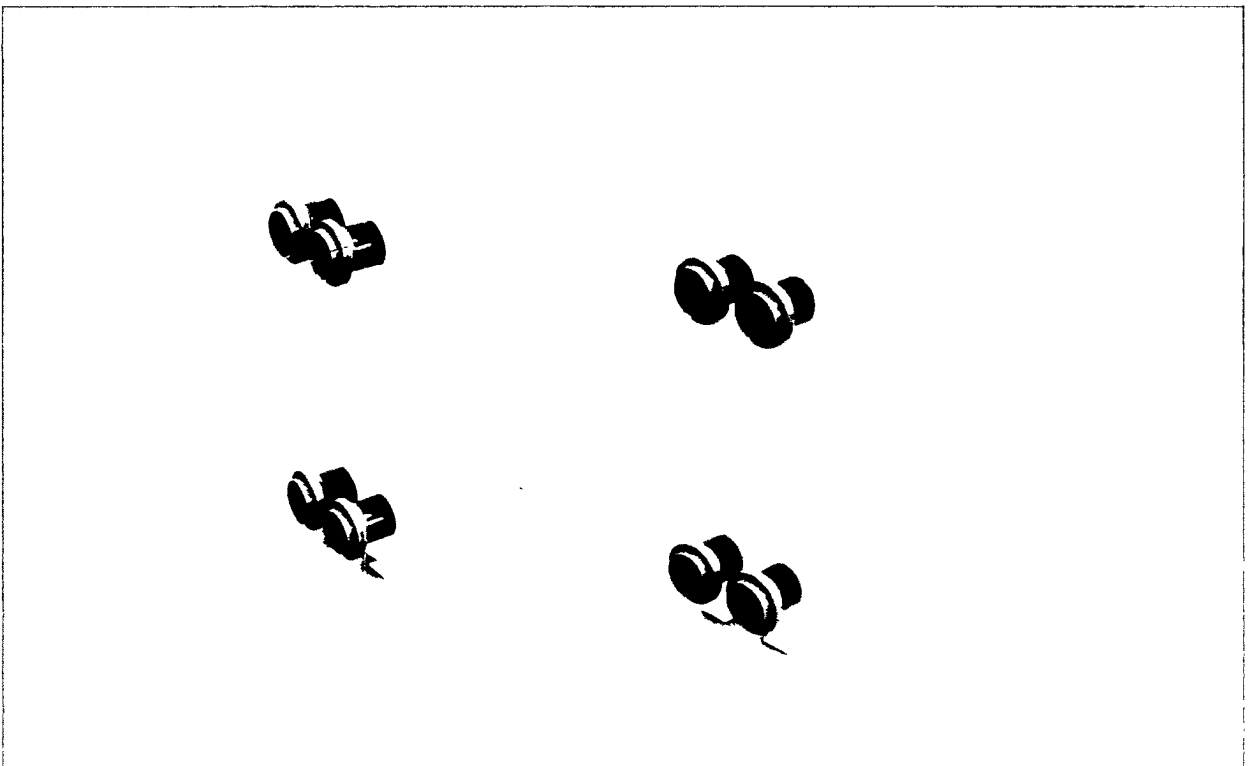

FIGURE 5-9: Plate-Type Cooler Models.

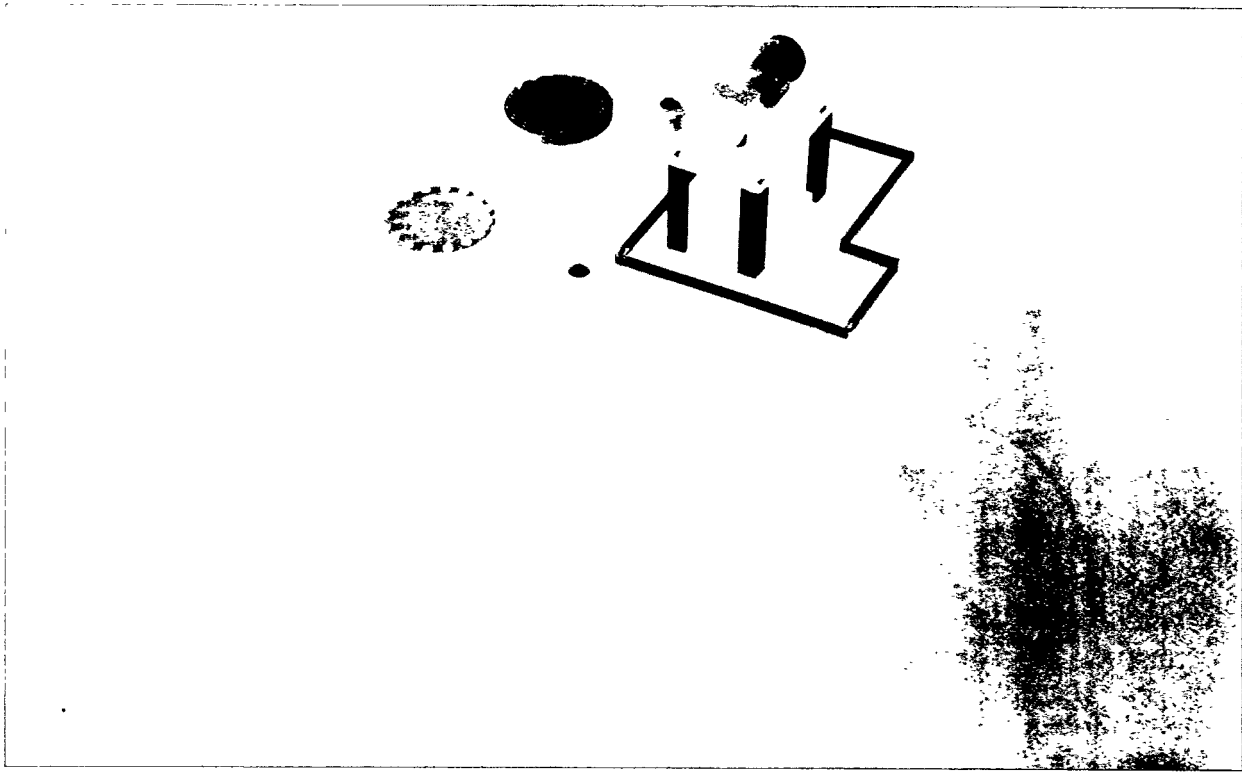

FIGURE 5-10: Model of a Tank With Pump.

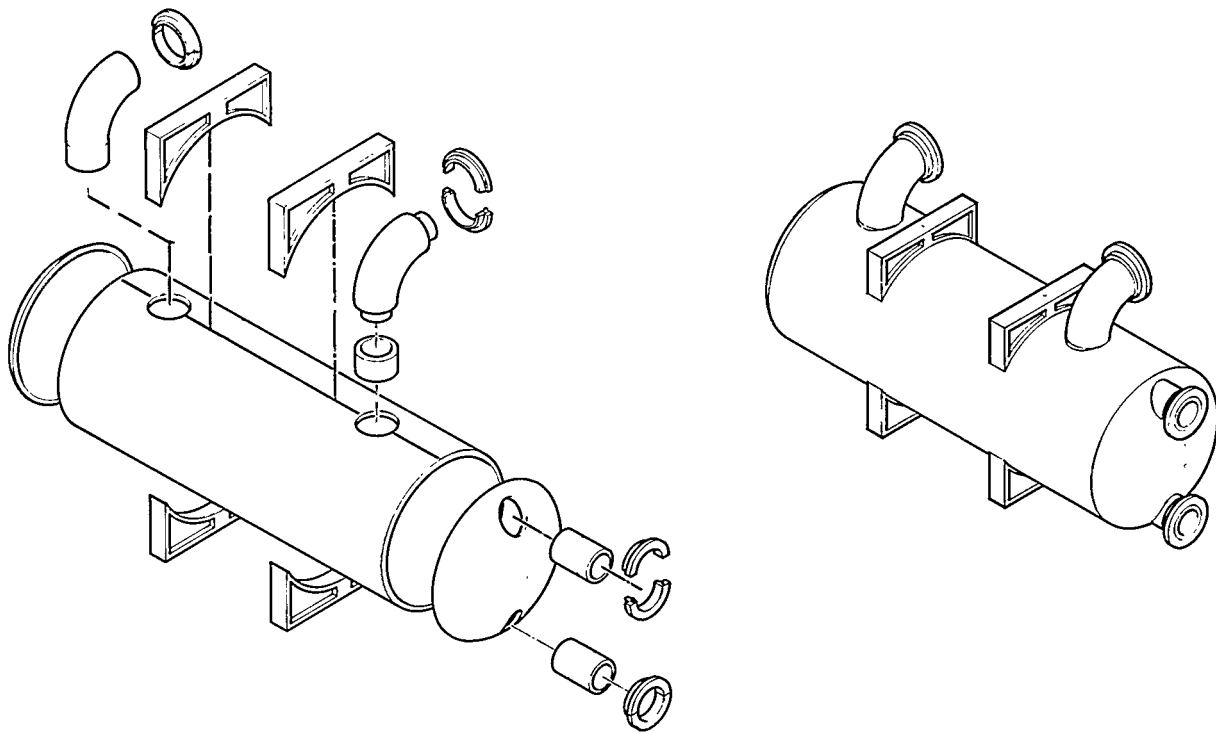
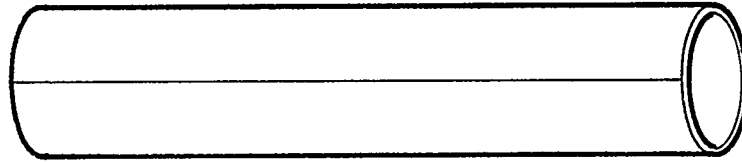
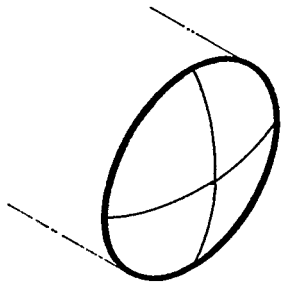

FIGURE 5-11: Tube-Type Heat-Exchanger Model. The parts shown are readily available from model-supply firms. Insulation thickness is included in the dimension for the outside diameter of the shell.

VESSEL TUBING



VESSEL HEADS



EXCHANGER FLANGE

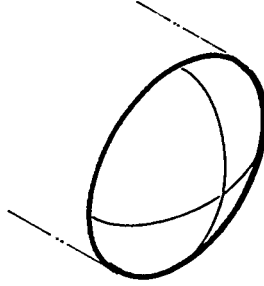

FLANGED HEAD

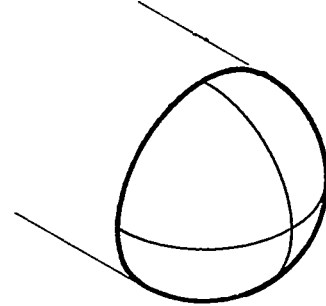

FLAT CAP

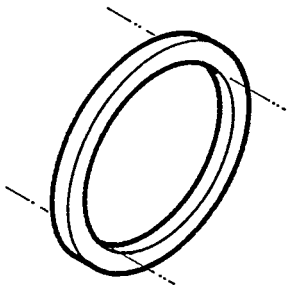

NOZZLE

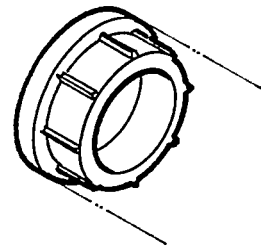
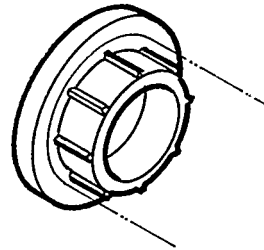

VESSEL SADDLE

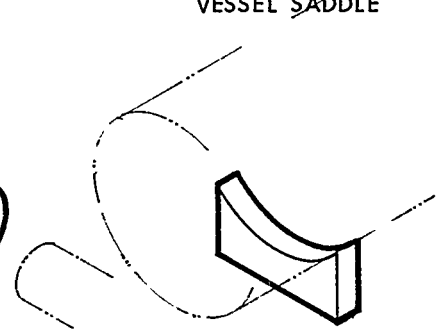
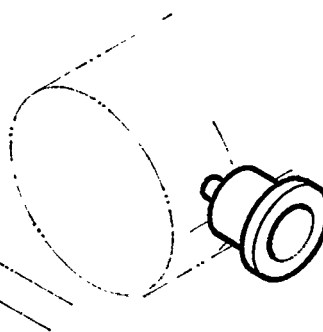
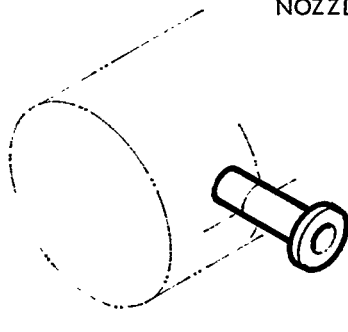

FIGURE 5-12: Standard Parts for Tube-Type Heat-Exchanger Models.

6.0 MODEL FITTINGS

Model fittings for piping, valves, ladders and such items other than machinery, are also important elements for design modeling. One of the keys to successful design modeling is the availability of sufficient types of modeled fittings manufactured to a certain accuracy. Many are standardized and are readily available from model-supply firms. Others are custom made usually by people assigned to assist design modelers.

6.1 Piping

Necessary conditions for materials needed to model pipe are:

- lightweight and strong,
- easy to work and assemble,
- inexpensive, and
- tight adherence to model components.

Such materials are produced in various colors including red, blue, yellow, green, orange, white, brown, black, purple, silver and gray. Advantages of color-coding modeled pipe-systems are:

- ease in identifying pipe runs, finding faults and locating problems,
- during meetings which include people other than modelers, understanding is enhanced,
- ease in assessing design-modeling progress, and
- ease in extracting design information.

Disadvantages of color-coding modeled pipe-systems are

- **more different material items must be procured and stocked,**
- **difficulty in estimating material requirements, and**
- **less flexibility in using materials.**

Accordingly, the numbers of colors employed should be consistent with the specific reasons for making a model.

Standard model parts for some modeled pipe-diameters are not available from model-supply firms. Therefore, design modelers sometimes employ available parts for the next largest modeled-pipe diameter. Appropriate dimensional adjustments are made when data is extracted for preparation of fabrication and assembly work instructions. Typical standard modeled-pipe items are shown in Figures 6-1 through 6-3.

Particular note should be made of the way insulation sleeves are attached as illustrated in Figure 6-3.

Models for non-standard valves and fittings should be custom made. Typical such items which are readily made from conventional model materials are illustrated in Figure 6-4.

6.2 Ventilation Ducts

Ventilation-duct models are made per layout drawings and are usually in ivory color. Round-duct models are made from acrylic tubing and acrylic hard-foam or sheet is used for rectangular duct. Typical sectioning for a vent-duct assembly is shown in Figure 6-5. All duct parts should be made before assembly starts.

Acrylic hard-foam is preferred over styrene foam because it:

- **generates less dust when sawn, and**
- does not dissolve as readily when painted.

Alphacyanoacrylate with a hardening quickner is a suitable adhesive.

6.3 Steel Work

Steel work in design modeling concerns tanks, auxiliary-machinery foundations, walkways, gratings, ladders, pipe supports, lifting beams, etc. Because they vary so much in form and size, their modeled counterparts are usually custom made from standard materials as shown in Figures 6-6 and 6-7.

6.3.1 Tanks

A model for a cylindrical tank is made from large-diameter pipe or by rolling ABS-resin sheet. A procedure for modeling a rectangular tank is given in Figure 6-8. The outside dimensions of an insulated-tank model, should include the insulation thickness. Sometimes, a different color plastic is used to indicate that a tank is insulated.

6.3.2 Foundations

When necessary, foundation models are detailed to the extent shown in Figure 6-9. Parts to be of the same length are bundled with adhesive tape for simultaneous cutting and finishing. Horizontal members are assembled first and the assembly is afterwards inspected for rectangularity. Legs are attached using a surface plate and square to insure perpendicularity. Gray-plastic angle-or square-bars, 9.5-, 6.4-, 4.8- and 3.2-millimeters wide are regularly used.

6.3.3 Walkways and Gratings

Walkways and gratings are made of colorless transparent acrylic-plastic sheet. Just their outlines are marked with blue quick-drying ink. There is no need for finish cutting nor are framework and supports modeled, as necessary details, easily derived from walkway and grating standards, are added during preparation of work instructions. At adequate intervals, vertical members, made from 3.2-millimeter angle, are added to hold the simplified walkways and gratings at their correct heights; see Figure 6-10.

6.3.4 Ladders

Standard ladder-materials of varying widths are available from model-supply firms. These are cut to length and mounted between simplified clear-plastic walkways and gratings as shown in Figure 6-11.

6.3.5 Stanchions and Handrails

Stanchions and handrails, although available as standard components, are not usually incorporated in design models except where there are special concerns as on landings at engine-room entrances. Such details, including those for ladders, are readily developed from standards while preparing work instructions.

6.3.6 Lifting Beams

Lifting beams that cannot be represented by standard plastic I-beams available from model-supply firms, are custom made usually from 3-millimeter thick sheet plastic.

6.3.7 Storeroom Racks

Framework for a storeroom rack is modeled with plastic angle-bars and shelves are made from plastic sheet.

6.3.8 Exhaust Pipes

Straight lengths of exhaust pipes are made from plastic tubing. Bends are created with purchased ells or mitered joints.

6.3.9 Pipe Bands

Pipe bands serve only to hold modeled pipe runs in their positions. They do not represent pipe supports to be fitted in an actual ship. As shown in Figure 6-12, pipe is adhered to pipe bands which are usually made from plastic angle- or square-bar. As also shown, other types are simply made from plastic sheet or are designed so that pipes can be snapped in and easily removed. The numbers of pipe bands used and their spacing should be just sufficient to avoid sagging pipe runs.

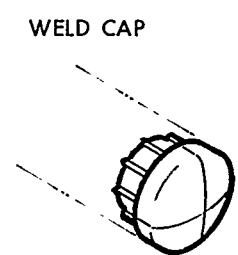
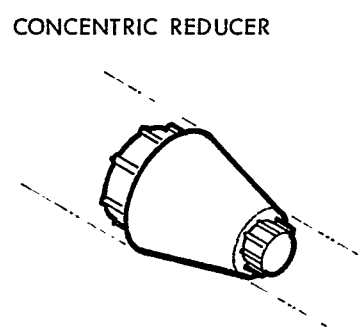
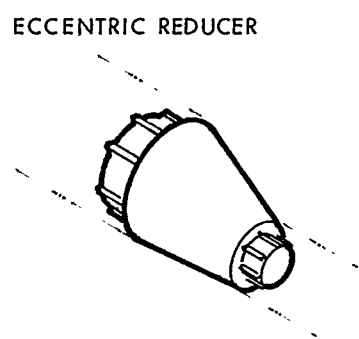
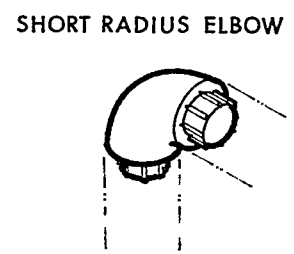
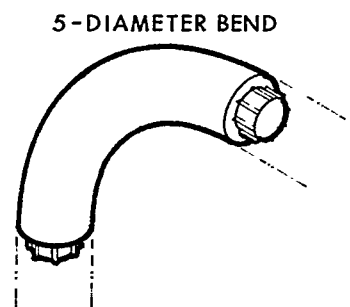
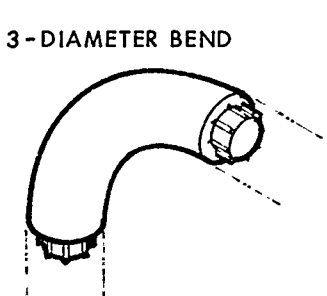
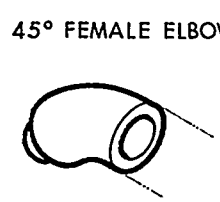
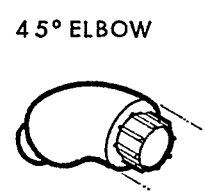
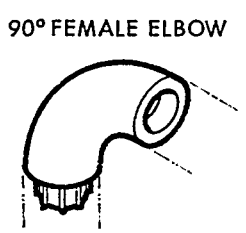
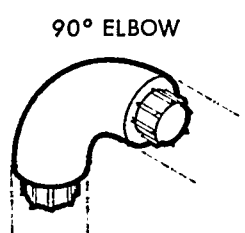
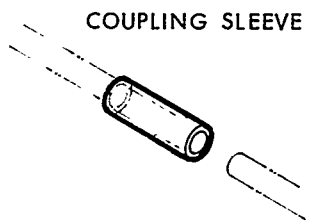
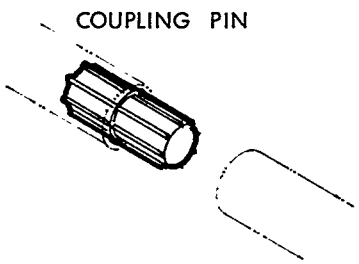
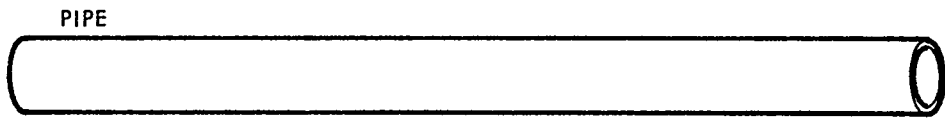

FIGURE 6-1: Standard Items for Pipe Systems

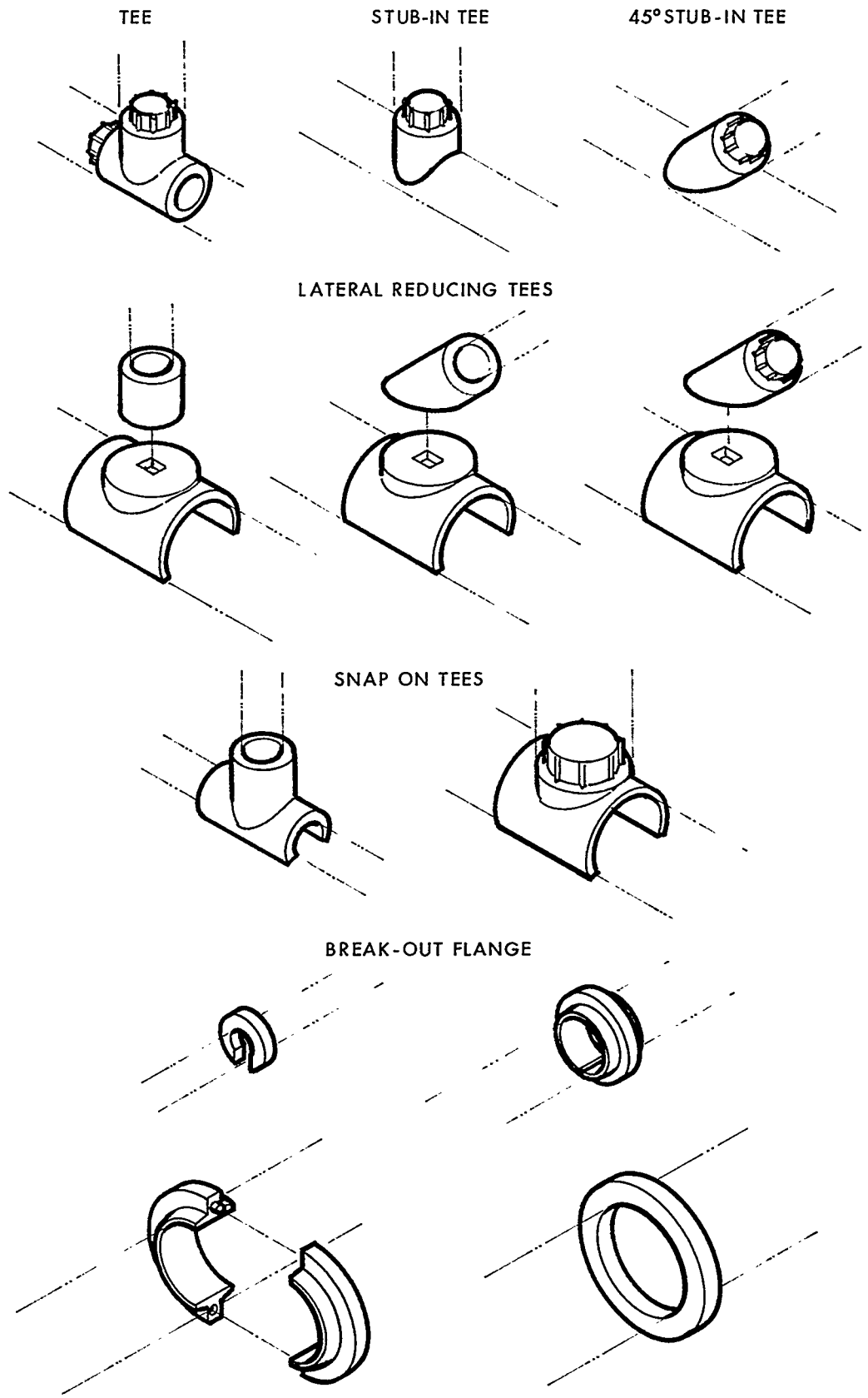
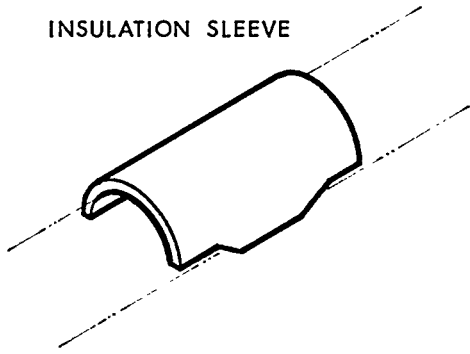
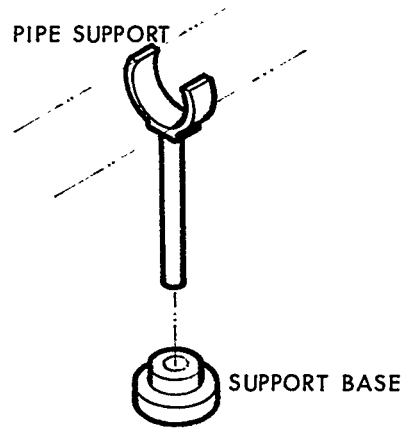

FIGURE 6-2: Standard Items for Pipe Systems.

INSULATION SLEEVE



PIPE SUPPORT



SUPPORT BASE

GATE VALVE

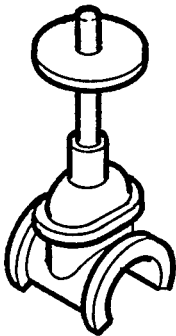

BUTTERFLY VALVE



GLOBE VALVE

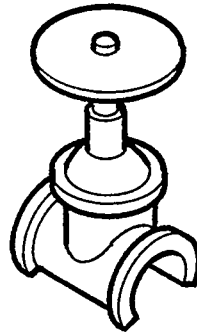

CHECK VALVE



PLUG VALVE

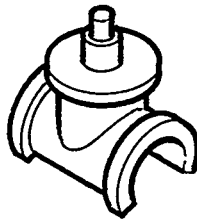

CONTROL VALVE

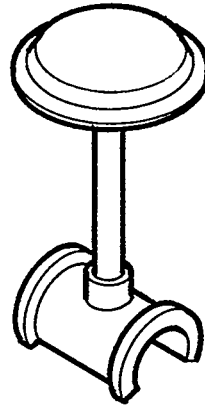

ANGLE VALVE

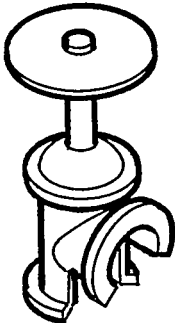

RELIEF VALVE

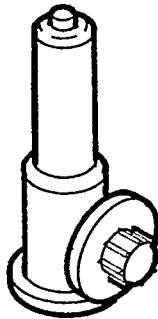

SAUNDERS TYPE VALVE

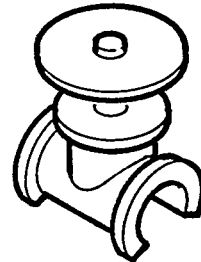
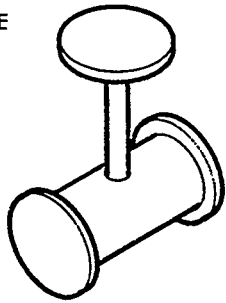
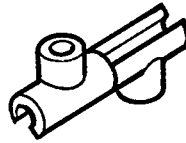

FIGURE 6-3: Standard Items for Pipe Systems.

GLOBE VALVE



DRAIN TRAP



STRAINER

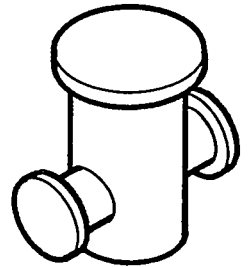

ANGLE VALVE

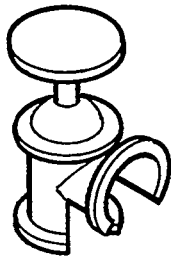

SPECTACLE BLANK FLANGE



THERMOMETERS

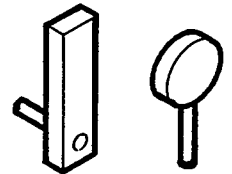

TEMPERATURE CONTROL VALVE

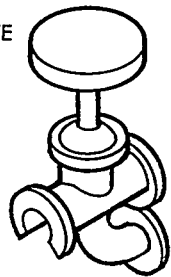

FLOW METER

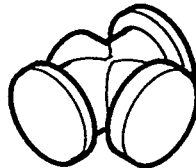

BOSS

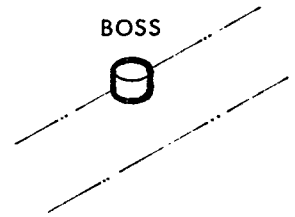

PRESSURE REDUCING VALVE

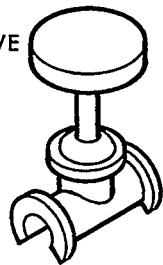

SIGHT GLASS

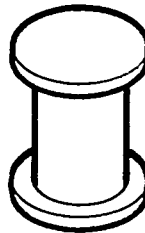

EXPANSION JOINT

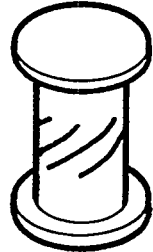

THERMO-WELL PIECE

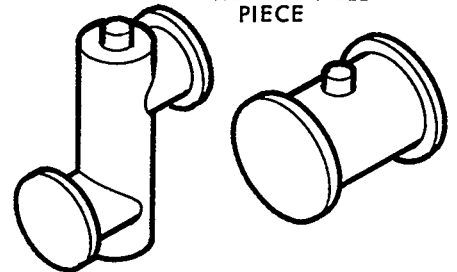
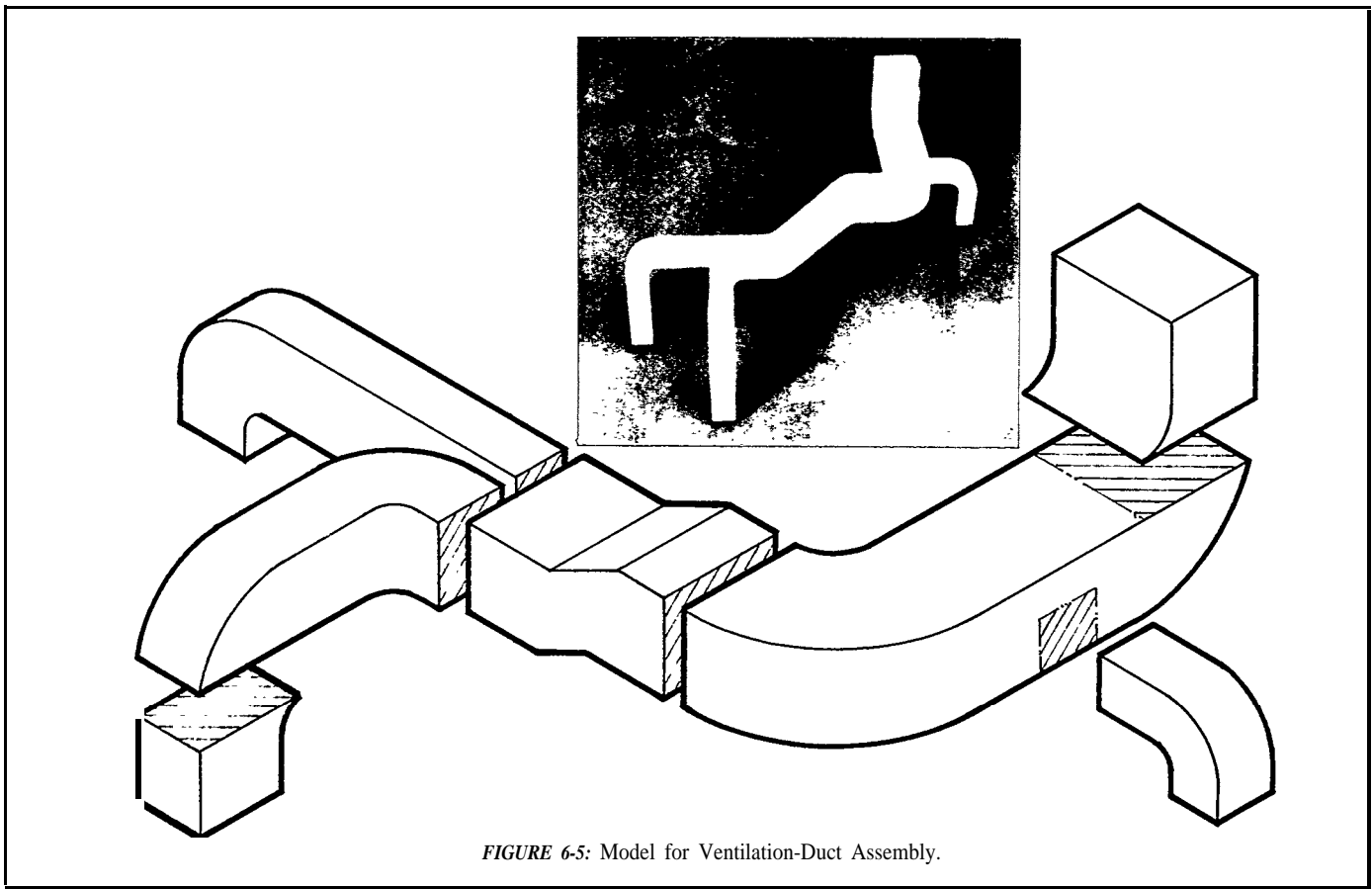
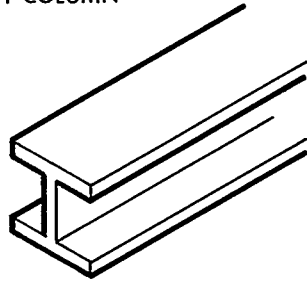

FIGURE 6-4: Typical Custom-Made Pipe System Fittings.



H COLUMN



I BEAM

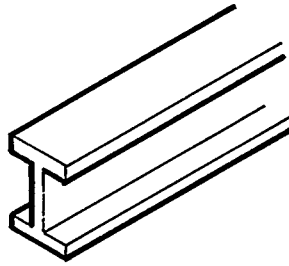

CHANNEL

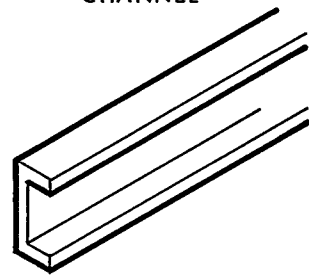

ANGLE

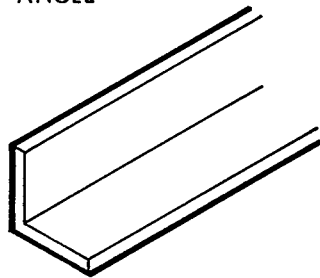

TEE

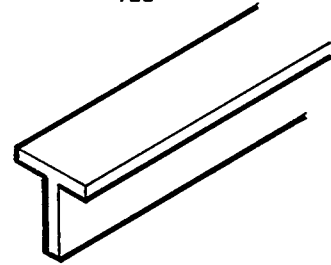

FIREPROOF COLUMN

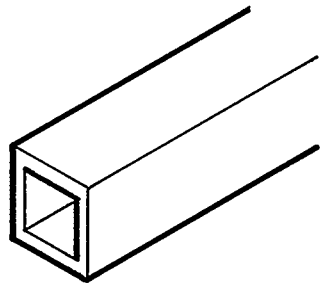

FIREPROOF BEAM

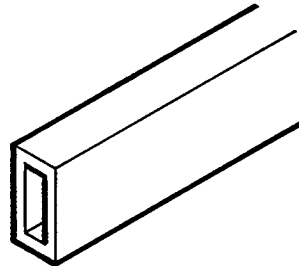

COLUMN BLOCK

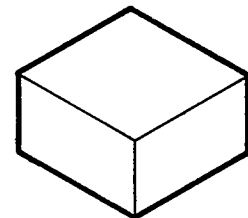

PLATFORM BRACKETS

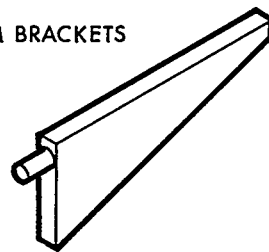
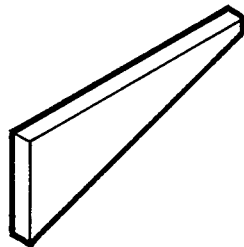
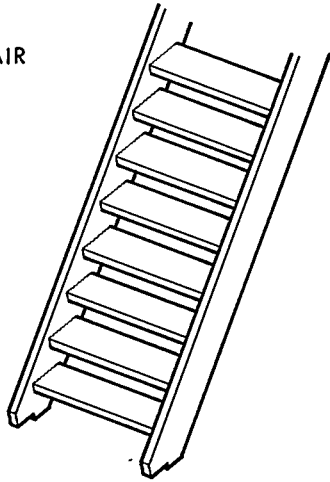
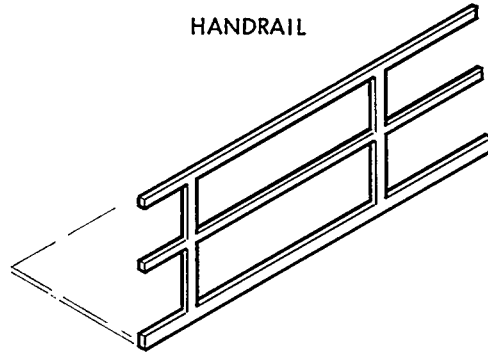

FIGURE 6-6: Standard Steel-Work Parts.

STAIR



HANDRAIL



LADDER

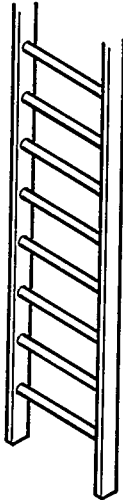

STAIR RAIL

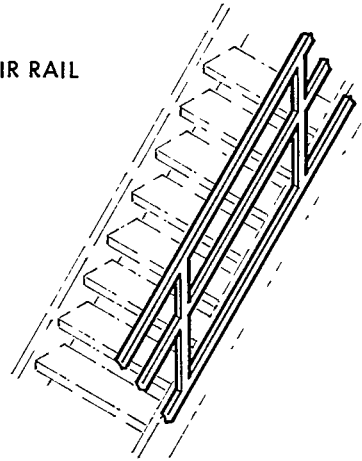

LADDER CAGE

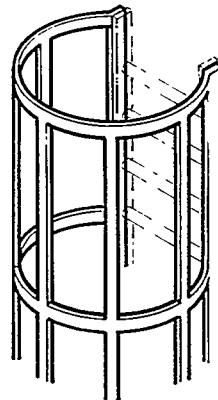

LADDER CLIPS

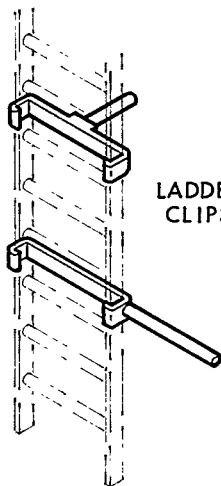
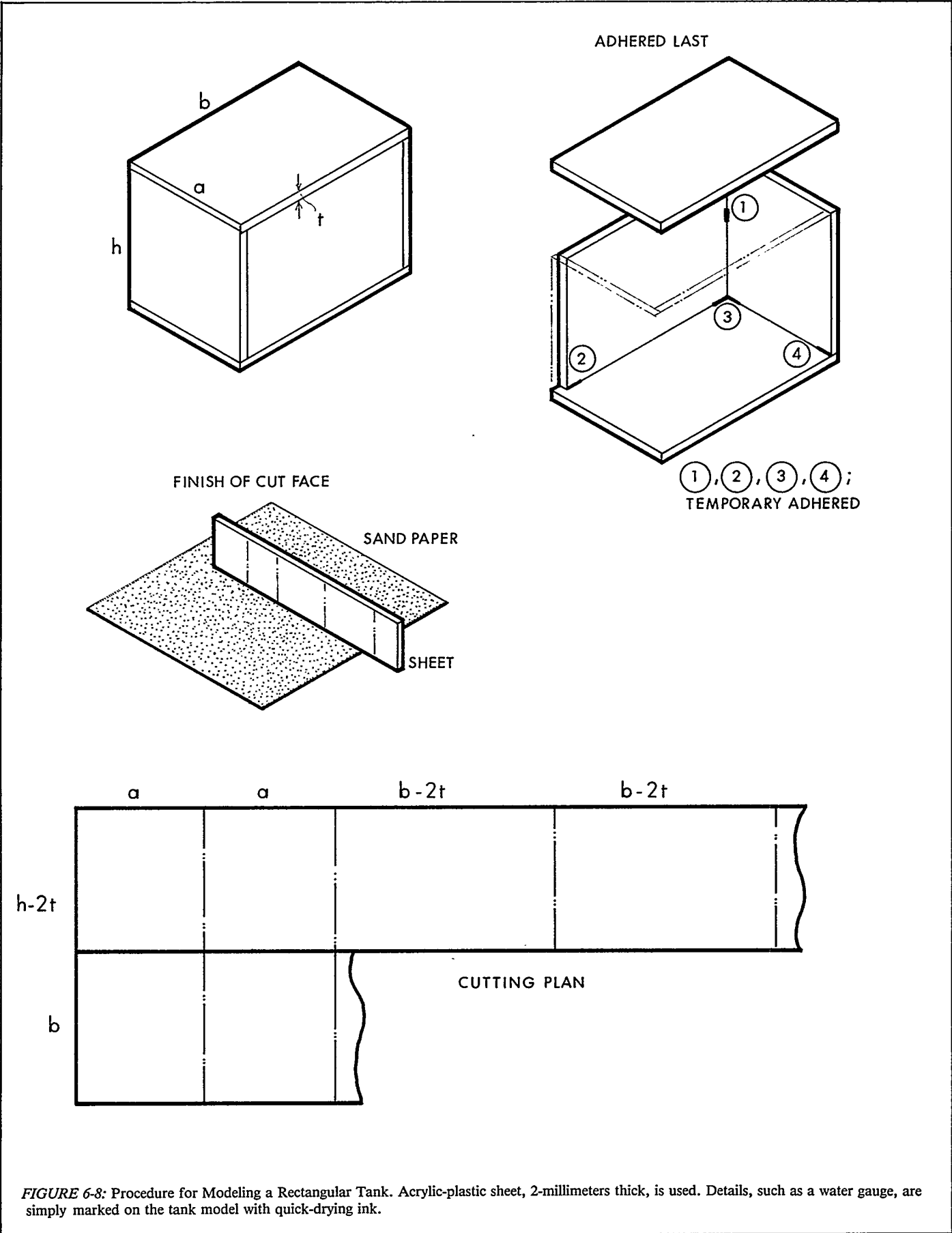

FIGURE 6-7: Standard Steel-Work Parts.



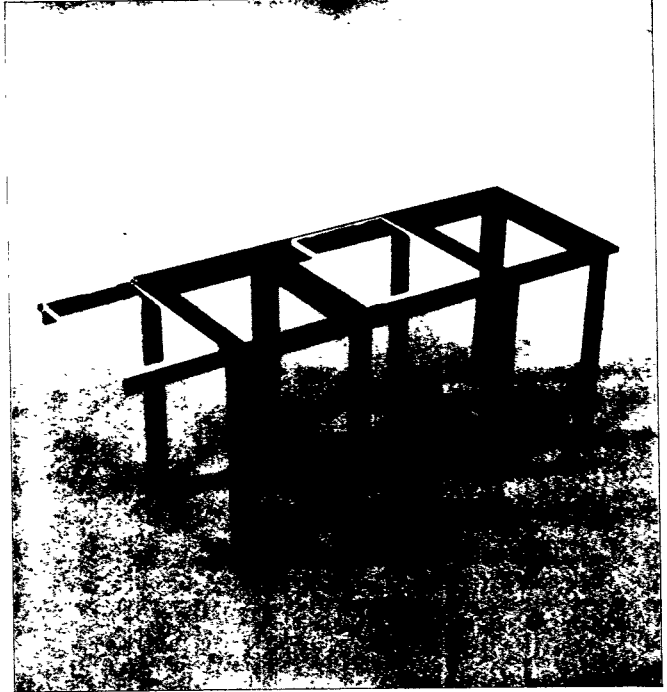

FIGURE 6-9: Typical Models of Foundation. The foundation on the right contains two floor plates which are made from transparent plastic.

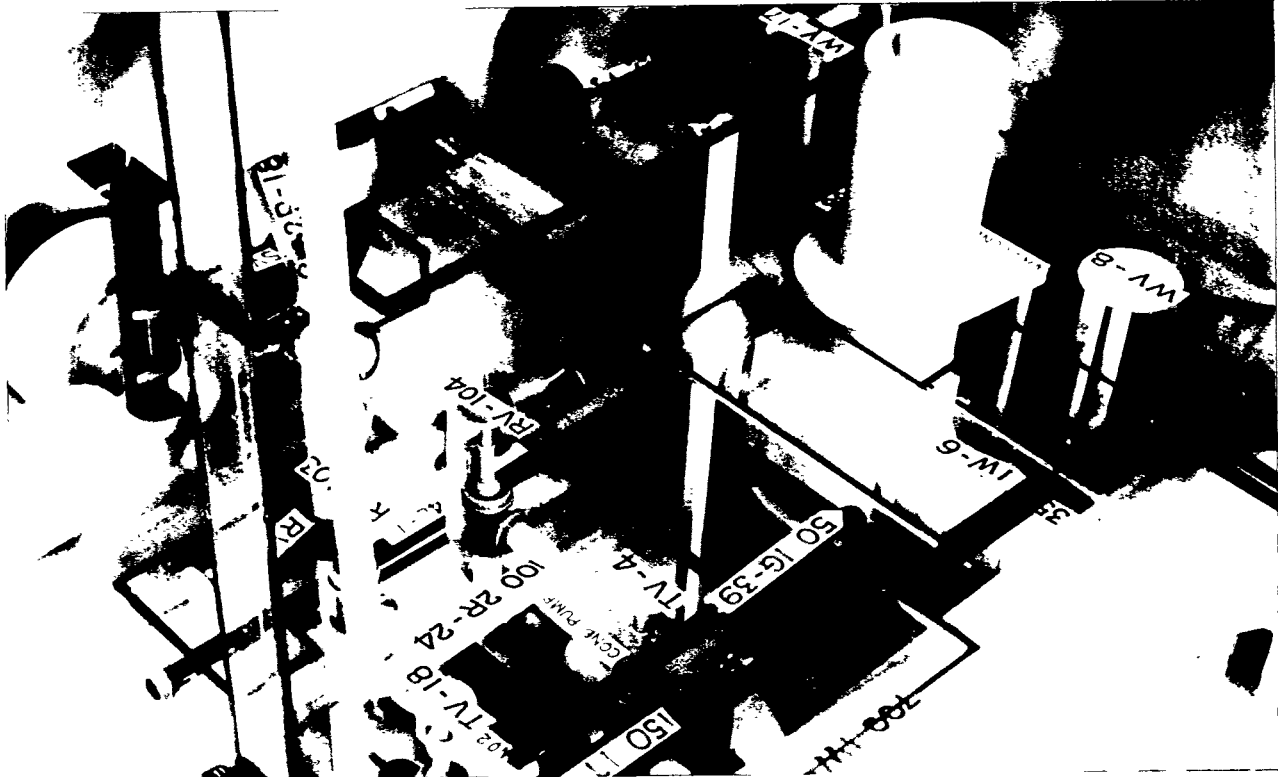

FIGURE 6-10: Walkways.

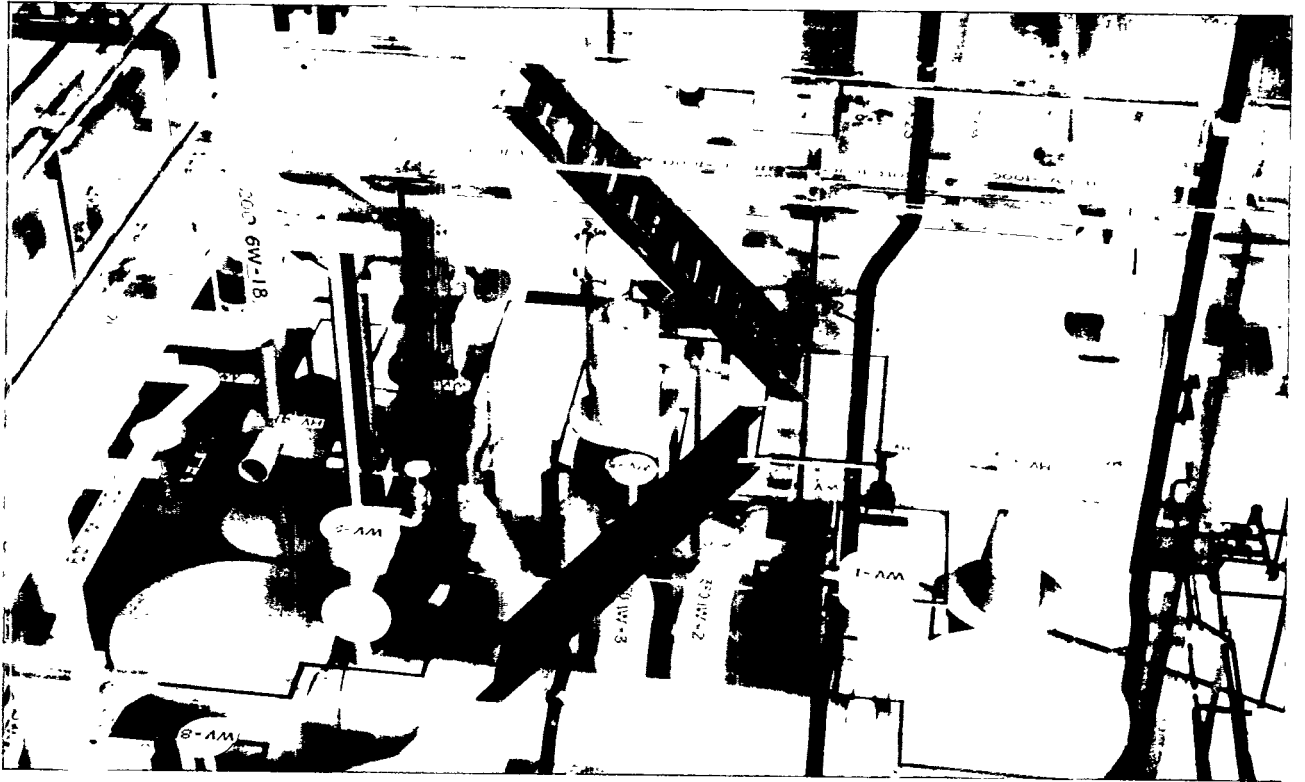

FIGURE 6-11: Ladders.

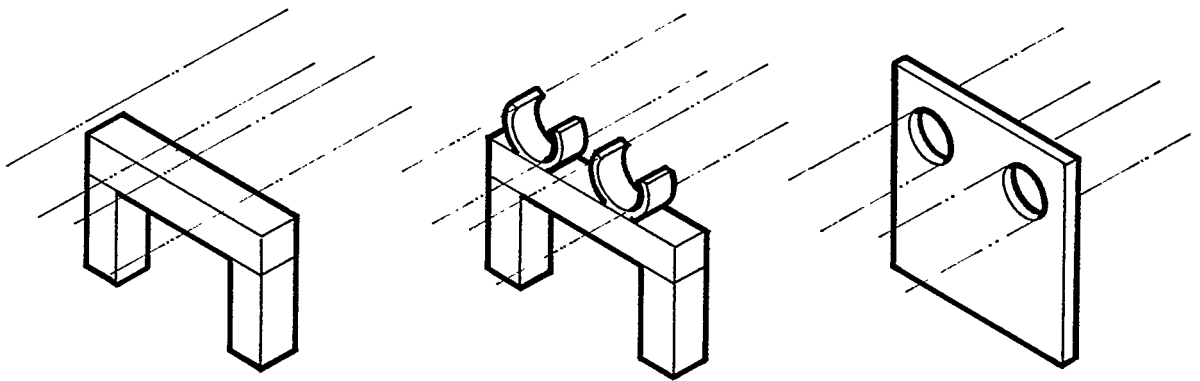

FIGURE 6-12: Various Types of Pipe Bands.

7.0 PIPING WORK

Piping work starts after models of machinery and other fittings are completed and is guided by rough layouts. Exact positions of pipe runs, particularly when not clear on rough layouts, are determined by design modelers within a model which already incorporates arranged machinery.

Piping work is rather easy. Pipe is cut or sawn to length and purchased snap-on elbows and tees are connected as shown in Figure 7-1.

7.1 General

As design models are composite arrangements which represent the final output of transition design, only the following pipe flanges should be represented:

- flanges needed to define interface boundaries for on-unit and on-block outfitting.
- flanges which define pipe runs for which slope is critical, and
- flanges needed for take-down joints.

The following considerations also apply:

- pipe quantities by diameters should be estimated in advance,
- a plan should be devised before start of piping work,
- required accuracy should be maintained,
- functions of pipe runs should be checked,
- care should be exercised for administration of materials, work schedules and man-hours.

7.2 Outfitting On-Unit

Units are classified according to function, e.g., auxiliary units, walkway units, piping units, tank units, etc. and various combinations thereof. Also, they are classified as small and large based on the quantities of fittings that are to be assembled.

Outfitting on-unit in design modeling is performed in accordance with rough layouts. Generally, machinery models are first arranged before foundations are attached. Pipes, valves, and other fittings are then assembled with walkways being last.

Each outfit unit is landed on a tank top, ceiling or deck of a hull-model section. Figure 7-2 show examples of outfitting on-unit.

7.3 Outfitting On-Block

Outfitting on-block consists of assembling individual components on-block, landing outfit units on-block and, more frequently, combinations of both of the foregoing.

Outfitting the ceiling side of a hull model-section, Figure 7-3, is performed as follows:

- a hull model-section is placed in an upside-down position on a work table so that fitting work can proceed down hand,
- outfit units, when they exist, are fitted first, then electric-cableways and trays, pipe and vent-duct runs, and fluorescent-light fixtures, in that order.

7.4 Outfitting On-Board

Outfitting on-board is the work of assembling remaining components after fitting work is completed in the hull model-sections and the sections are assembled together. The work mostly consists of attaching connecting pipes between hull sections and finishing the installations of walkways and ladders; see Figure 6-11. At this stage some modification work is usually encountered.

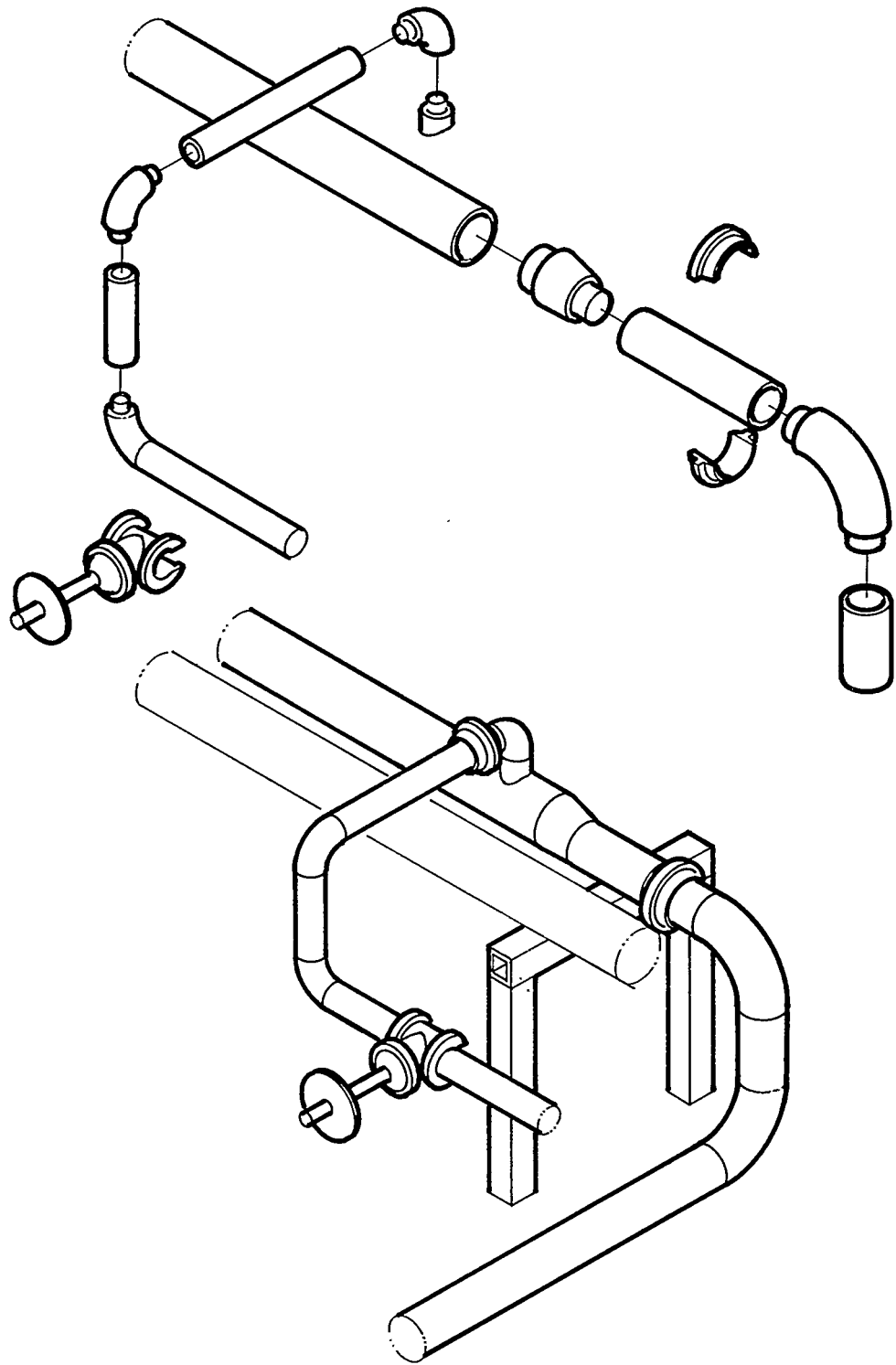

FIGURE 7-1: Piping Assembly.

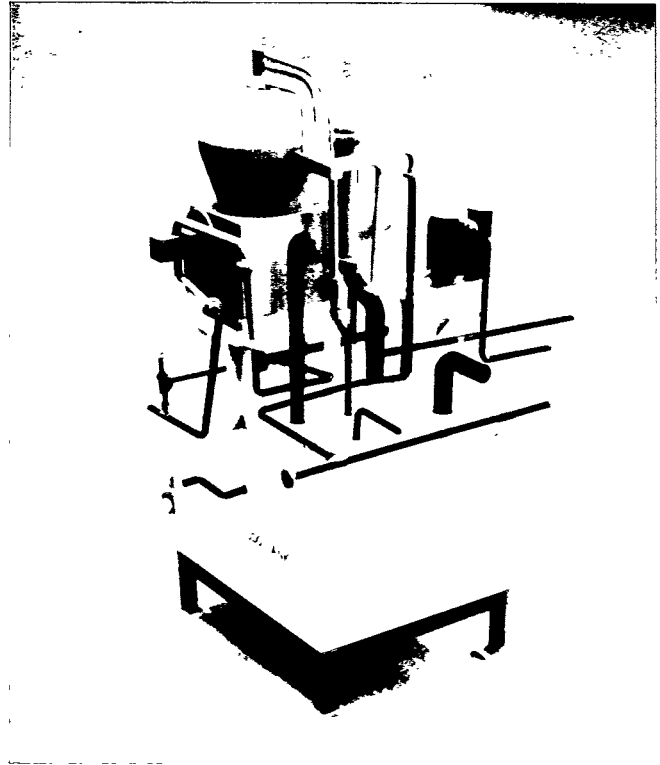

FIGURE 7-2: Outfitting On-Unit.

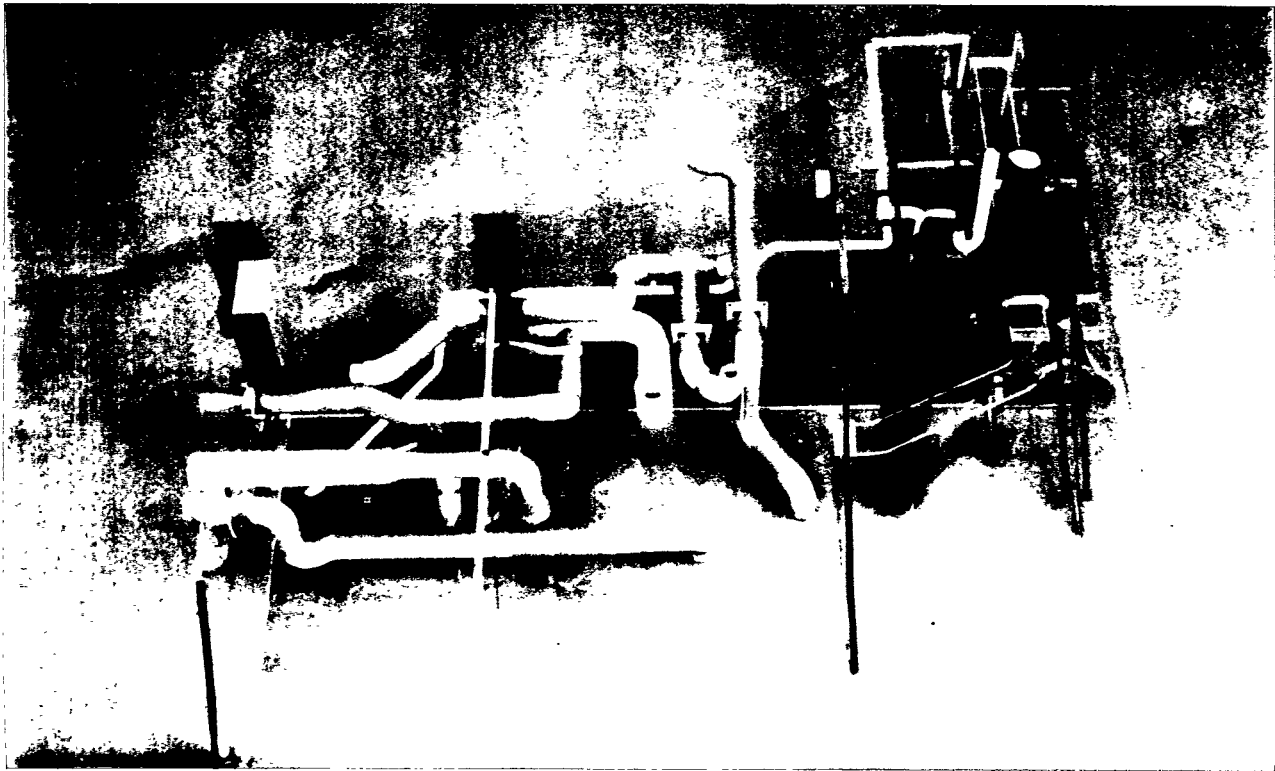

FIGURE 7-3: Outfitting On-Block (Ceiling).

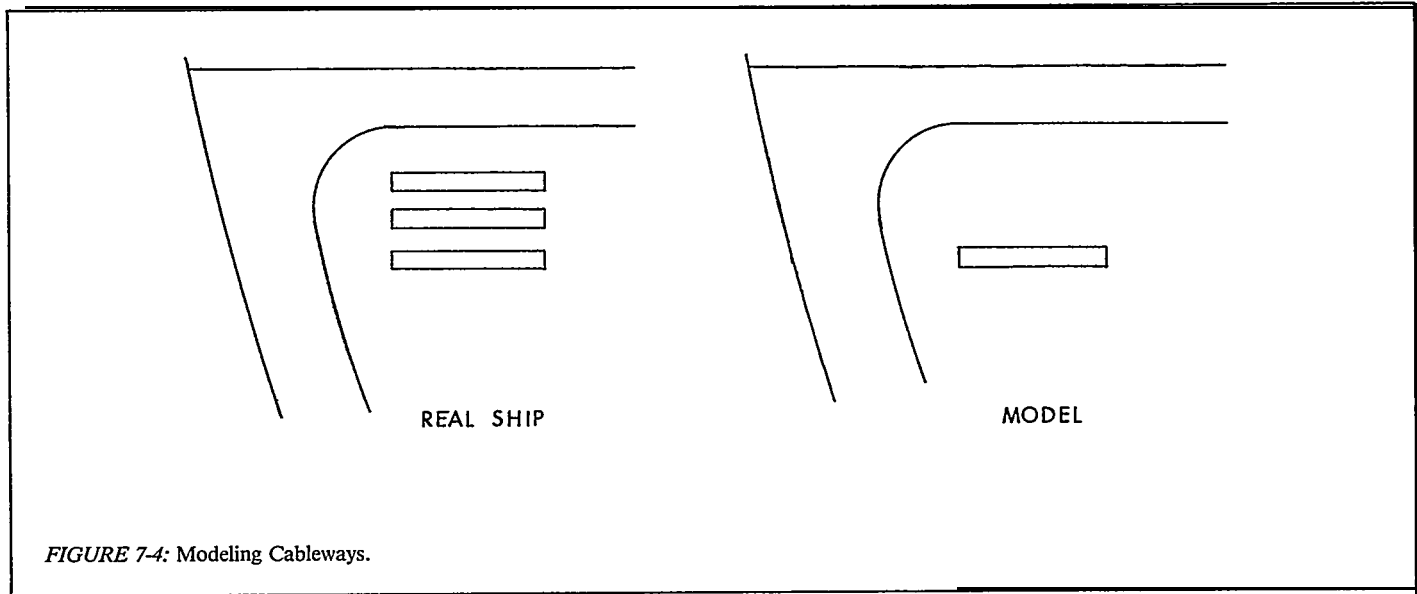

FIGURE 7-4: Modeling Cableways.

7.5 Electrical Equipment

Main cableways are modeled with fluorescent-green acrylic-plastic sheet, 2-millimeters thick, in accordance with rough layouts. Small cableways are usually not modeled as they can be defined during subsequent preparation of work instructions. Although cableways are usually fitted with more than one tray in a real ship, providing for only the lowermost tray is sufficient for design modeling; see Figure 7-4. Sometimes, labels are attached which indicate the actual number of trays.

Large controllers, such as for control centers, are modeled from acrylic-plastic sheet or hard foam. Small panels are deferred for inclusion in work instructions.

Generally only fluorescent-light fixtures to be arranged on engine-room ceilings are modeled. They are simply made from acrylic-plastic sheet and rod as shown in Figure 7-5.

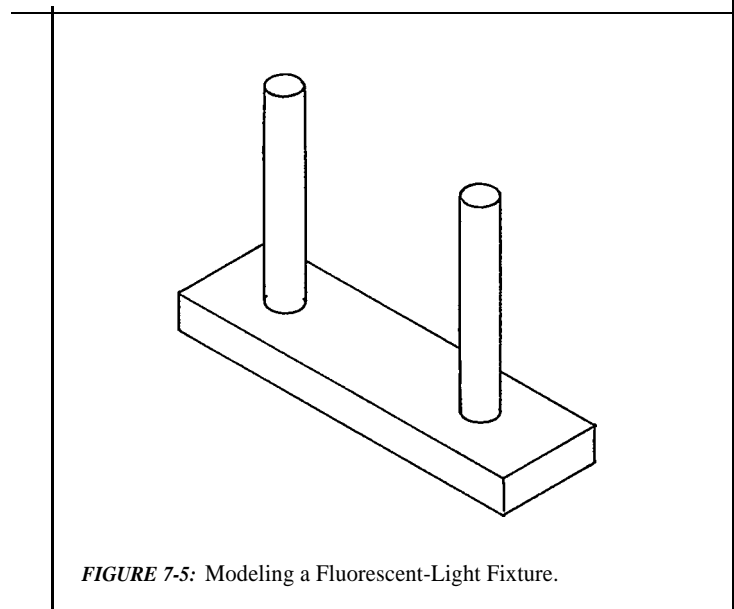

FIGURE 7-5: Modeling a Fluorescent-Light Fixture.

8.0 WORK INSTRUCTIONS DERIVED FROM MODELS

Although a number of sophisticated methods exist for extracting information from models to facilitate use of a computer for preparing fabrication and assembly drawings, they are not yet applied as standard practice. Instead, the method most widely used is manual dimensioning from models and, because of market circumstances requiring many relatively simple ships, even manual preparation of drawings prevails. Typical drawings produced from models are:

- assembly drawings for outfitting on-unit, on-block and on-board, and
- fabrication drawings for pipe and vent-duct pieces, foundations, walkways, ladders, tanks, etc.

8.1 Assembly Drawings

8.1.1 Drawings for Outfitting On-Unit

Two types of drawings are used for providing design details and designating assembly work for outfitting on-unit. The first is a composite for only a specific unit and is appropriate if the unit is to be assembled by relatively inexperienced workers or by a subcontractor. The second is a composite arrangement drawing which typically encompasses much more. Each depicts components for work packages for outfitting on-unit, on-block and on-board, their relationships to each other, and how they are interconnected, i.e., the role of each assembly work package in the overall scheme for outfitting on-unit, on-block and on-board is shown. Where workers are experienced enough, the latter type drawings are preferred. Typical drawings which contain work instructions for outfitting on-unit are shown in Figures 8-1 and 8-2. Such drawings are sufficient for producing pipe-piece fabrication drawings.

8.1.2 Drawings for Outfitting On-Block

The boundaries and number of each hull block are marked on composite drawings as shown in Figures 8-3 and 8-4. Locations and piece numbers of fittings to be assembled on-block must be the same in both fabrication and assembly drawings. And, the number of a destination hull block must appear on each fabrication drawing.

8.1.3 Drawings for Outfitting On-Board

Fittings to be assembled on-board are needed during hull erection to join together the various outfit units which have been “blue sky” landed and outfitted blocks. Such fittings are shown and designated for on-board fitting work on composite drawings such as those described in Part 8.1.1. Thus, no special assembly drawings are required. Further, designation for on-board assembly appears on the fabrication drawings for such fittings.

8.1.4 Other Assembly Drawings

Positions of independent tanks, walkways and vent ducts are usually superimposed on the composite drawings and could be designated for outfitting on-unit, on-block or on-board. Sometimes a separate drawing can be effectively employed for both fabrication and assembly of a number of walkway or vent-duct components.

8.2 Fabrication Drawings

8.2.1 Pipe Pieces

Methods for obtaining pipe-piece dimensions from design models include:

- direct use of 3-dimensional digitizers,
- digitizing from composite drawings based on the model, and
- manual take-off of dimensions directly from the model.

Figure 8-5 shows a typical pipe-piece fabrication drawing, i.e., work instruction, resulting from computer processing of the dimensions obtained by any of the methods noted. In addition to required dimensions, such work instructions include material lists, flange ratings, fabrication instructions, etc. All necessary information for a shipyard's or subcontractor's pipe shop to make a specific pipe piece is included.

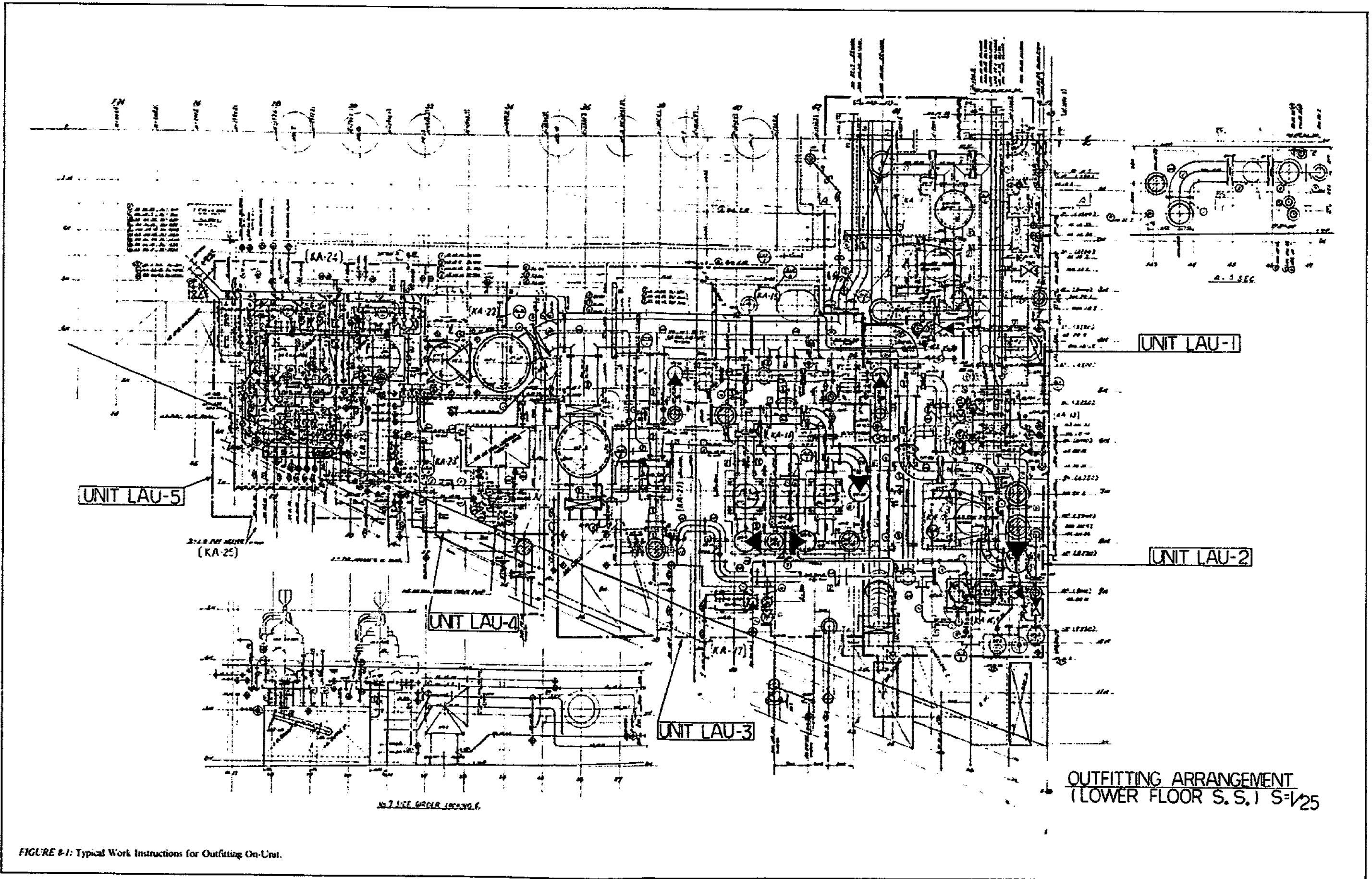
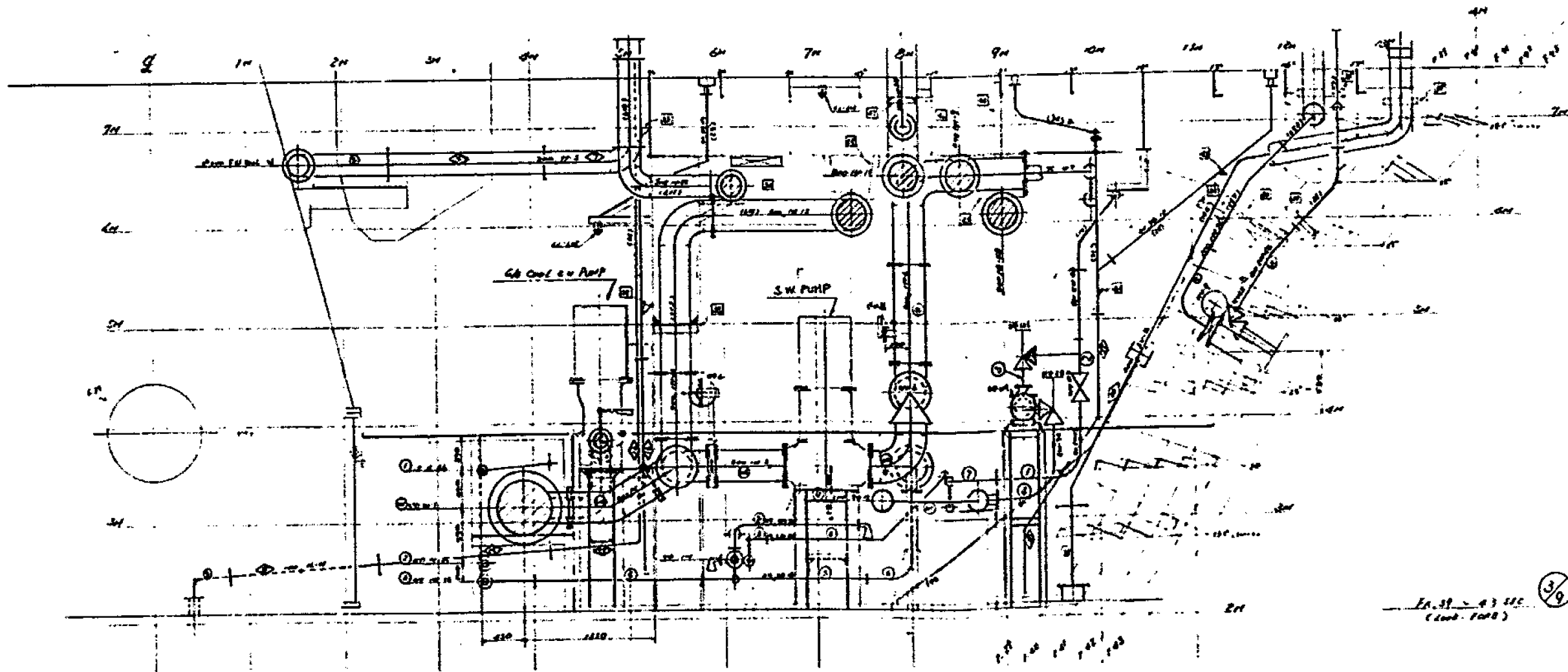

FIGURE 8-1: Typical Work Instructions for Outfitting On-Unit.



OUTFITTING ARRANGEMENT
(LOWER FLR S.S. SECT. VIEW)

FIGURE 8-2: Typical Work Instructions for Outfitting On-Unit.

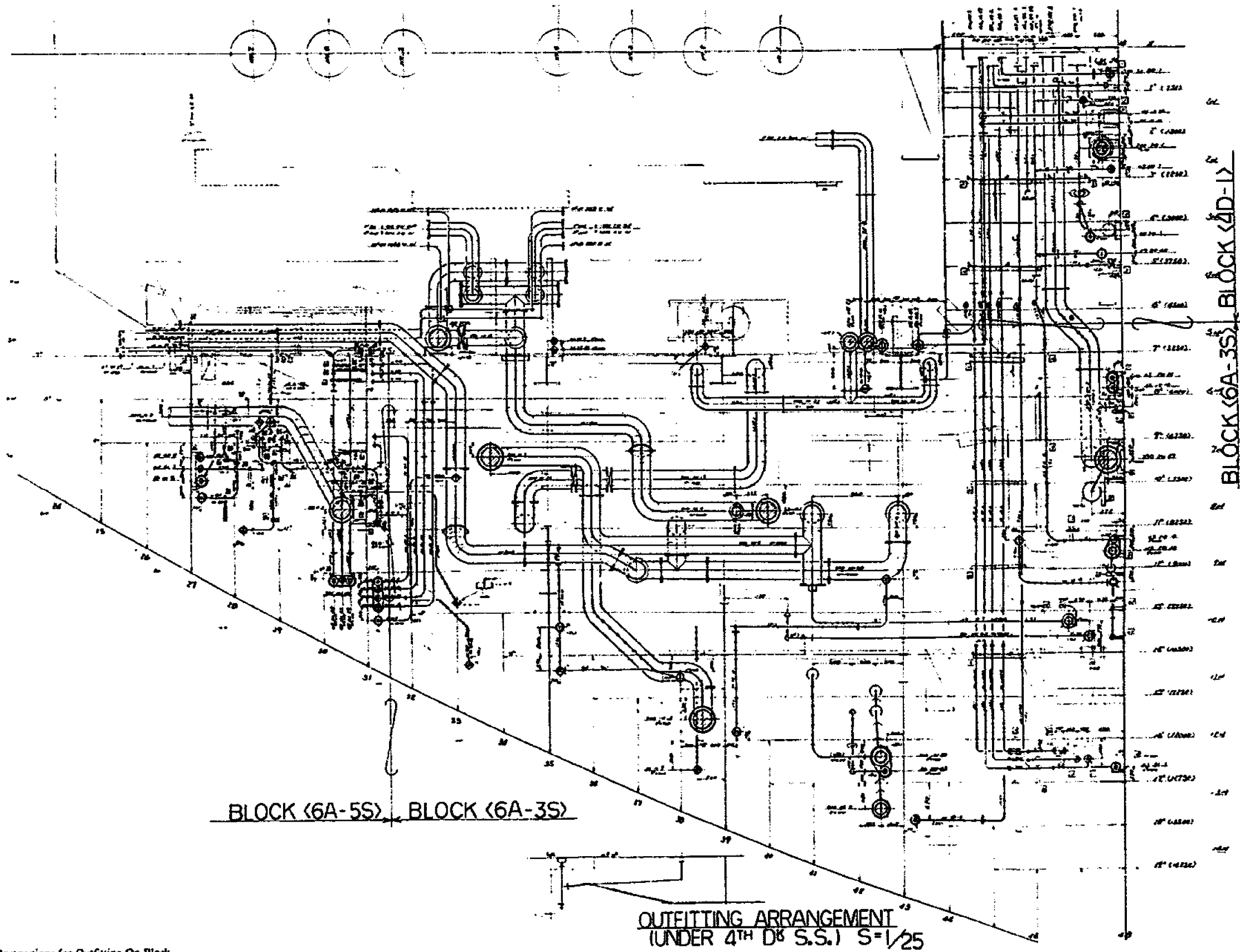

FIGURE 8-3: Typical Work Instructions for Outfitting On-Block.

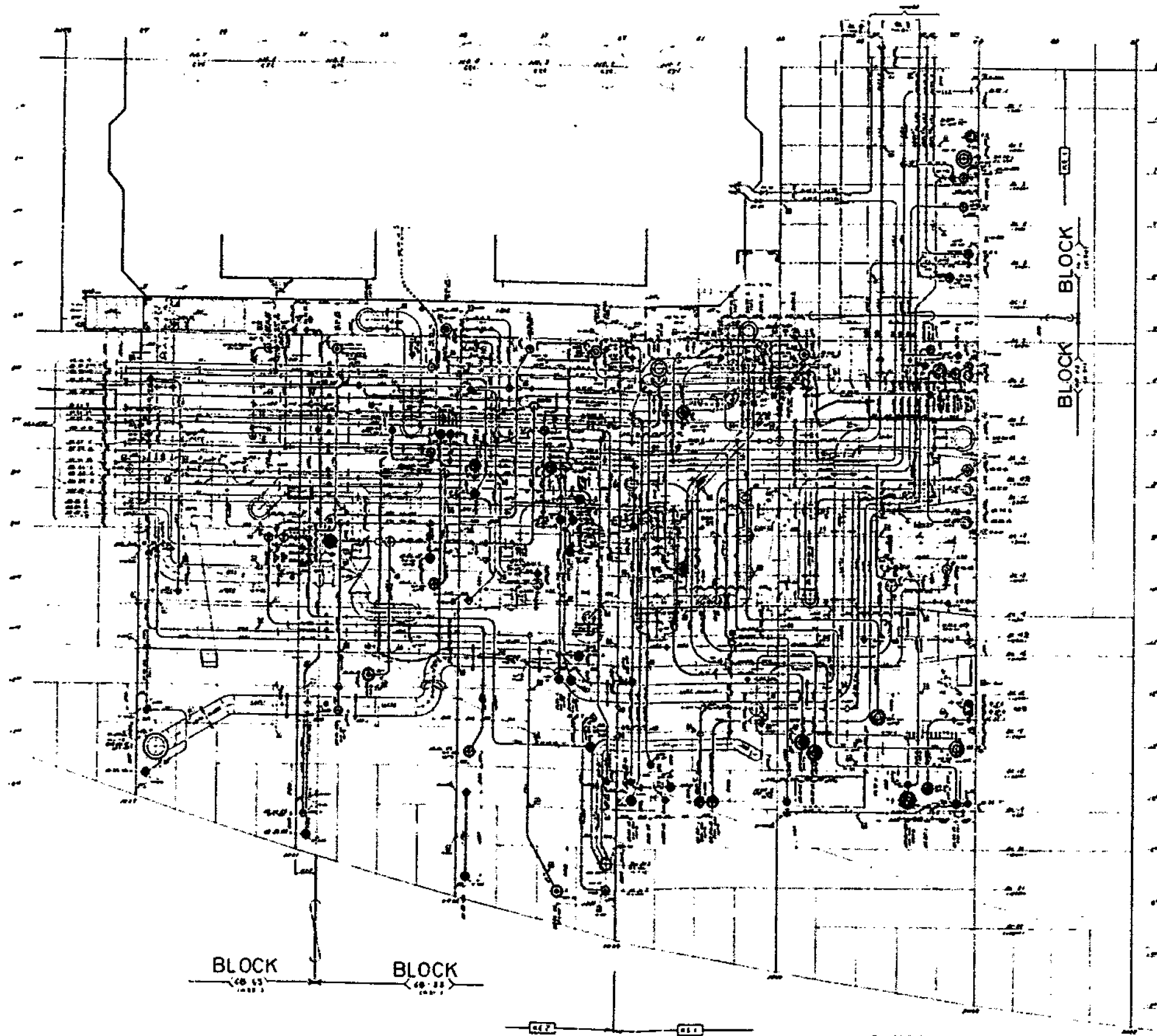

FIGURE 8-4: Typical Work Instructions for Outfitting On-Block.

OUTFITTING ARRANGEMENT
(UNDER 3RD DB S.S.) S-1/25

S-NO. 9801 (M) SHEET NO. 77A50321 (REV-) DATE: 83-09-13 PAGE: 227 ()
 AREA: M32 BLOCK: 6-1BP UNIT: STAGE: B
 <PIPE NO. > < TREATMENT >
 LINE No. REQ'D HYD. PRESS X LAY IN-PAINT OUT-PAINT
 OX- 1-05- - (REV-) 1 - I -2

| < MATERIAL TBL. > | | | | < PRODUCT TBL. > | | | |
|-------------------|------------|-------------|-------|------------------|--------|--------|-------|
| No. | RATING. | SYMBOL | REQ'D | CUT. L | FL. W. | R-ANG. | BR. L |
| 1- 4 | JE4- - 40- | STPG38-E#40 | 1 | 3960 | | | |
| 4 | F - 5- 40- | SS41 | 1 | | 10K | 0. 0 | 0. 8 |
| 1 | F - 5- 40- | SS41 | 1 | | 10K | 0. 0 | 0. 8 |

| < BENDER TBL. > | | | |
|-----------------|-------------|--------|-----------------------------------|
| START L | NC-L | FA | A : L NC-L RA |
| 1 | 3782 (3282) | +45. 0 | 90. 0 : 3356 (196) +180. 0 90. 0 |

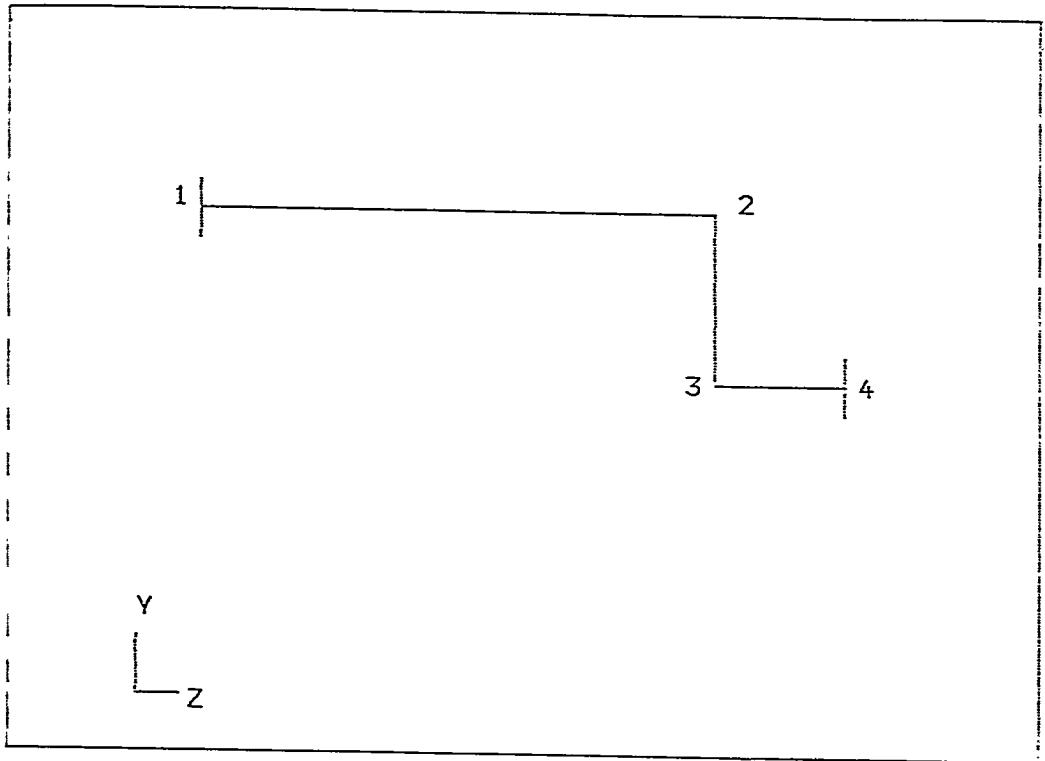

| FM TO | NAME | ANG. | RATING. | ASS. | DIM. X | TBL. Y | Z | N | AL&L |
|-------|------|------|---------|------|--------|--------|------|---|------|
| - 1 | FL | | F - 5- | 40- | | | | | |
| 1- 2 | BR | 90 | | 40 | | | 3276 | | 3276 |
| 2- 3 | BR | 90 | | 40 | | -496 | | | 496 |
| 3- 4 | FL | | F - 5- | 40- | | | 336 | | 366 |

* TOTAL LENGTH: X= Y= 496 Z=3612 *** TOTAL WEIGHT: 18KG ****

M: / IC: / IB: / IF: / IN: / IG: / IS: / IE: / IH: /

FIGURE 8-5: Typical Work Instruction for Fabricating a Pipe Piece.

8.2.2 *Auxiliary Machinery Foundations*

As previously noted, models of foundations are highly simplified. Hence, drawings for actual foundations must take into account many more considerations, such as, strength, size, space requirements, etc. Attachment details and designation for on-unit or on-block assembly must be shown on each fabrication drawing. Figures 8-6 and 8-7 are examples of fabrication drawings for auxiliary machinery foundations. In general, they are nearly identical to traditional practice.

8.2.3 *Walkways and Ladders*

Drawings for walkways and ladders are usually made by manual dimensioning from models and manual drawing preparation. Walkway fabrication and assembly details generally appear on the same drawing. See Figure 8-8 through 8-11.

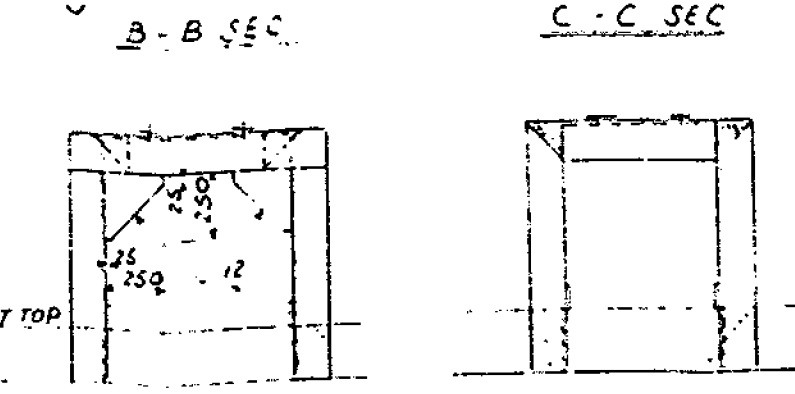
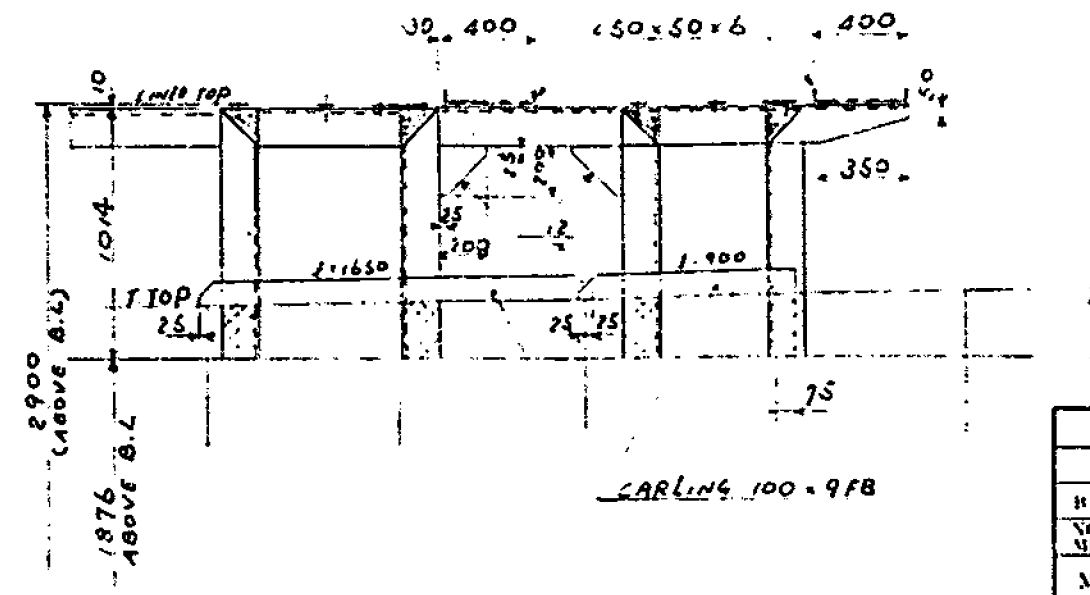
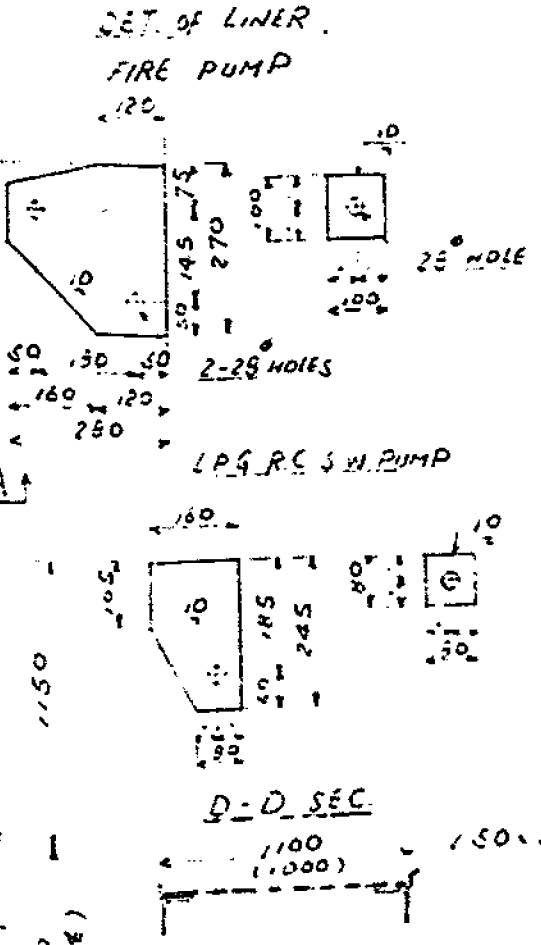
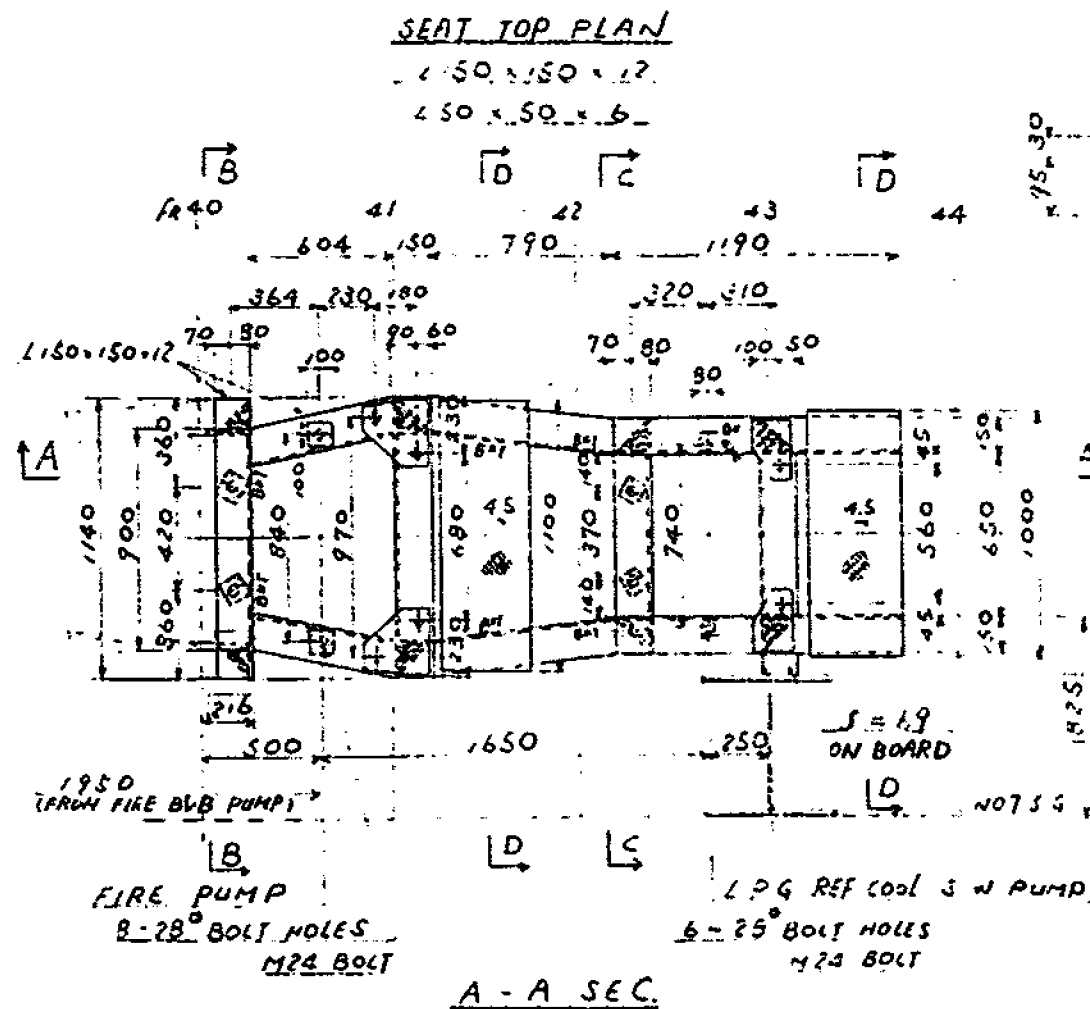

| NOTE | | |
|------------|------|--------|
| MANUF. NO. | DATE | REMARK |
| | | |

| MATERIAL | | | STAGE |
|----------------------|------|-------|---------|
| 150 x 150 x 12 | 17.0 | 262.1 | UNIT |
| 50 x 50 x 6 | 5.8 | 25.7 | (KB13) |
| CARLING 100-9FB | 5.1 | 36.0 | BLOCK |
| 24 PL 45° | 0.86 | 31.1 | (IB-3P) |
| LINER 270 x 290 x 10 | 2 | 11.9 | AREA |
| 100 x 100 x 10 | 4 | 3.1 | KBI |
| 245 x 160 x 10 | 2 | 6.2 | |
| 80 x 80 x 10 | 4 | 2.0 | |
| 6KT. 250 x 250 x 12 | 2 | 11.8 | |
| 200 x 200 x 12 | 4 | 15.8 | |
| TW-607.7 | | | |

FIRE PUMP SEAT
 LPG REF COOL
 S.W. PUMP SEAT
 S = 1/25

| B | A | PA | NAME OF PART | NOMINAL OR DIMENSION | MATERIAL | UNIT WEIGHT | REMARK |
|-------|----|----|--------------|----------------------|----------|-------------|--------|
| NO OF | NO | RT | | | | | |
| | | | | | | | |
| | | | | | | | |

FIGURE 8-7: Typical Work Instruction for Fabricating an Auxiliary-Machinery Foundations.

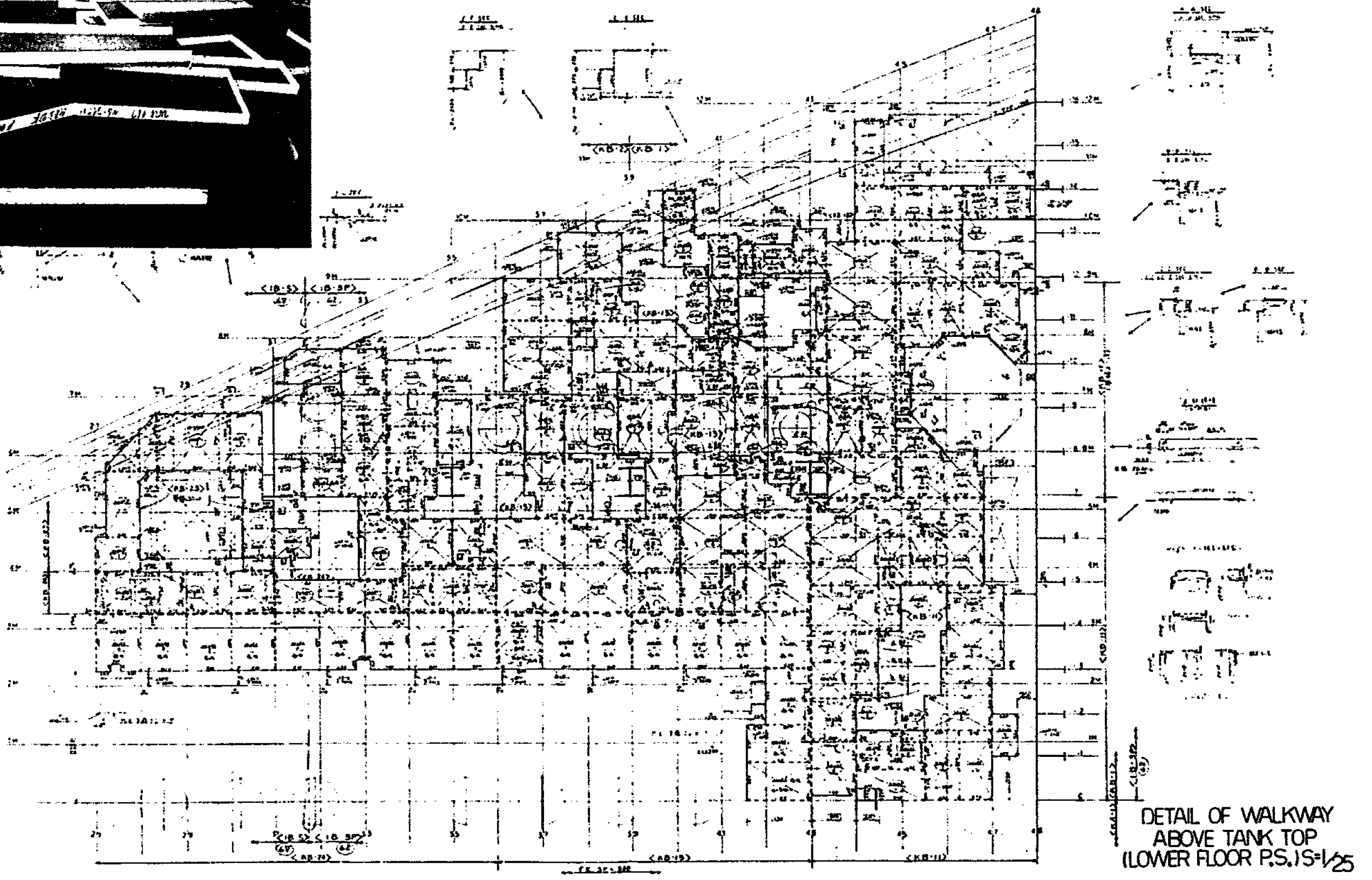

FIGURE 8-8: Typical Work Instruction for Fabricating and Assembling Walkways.

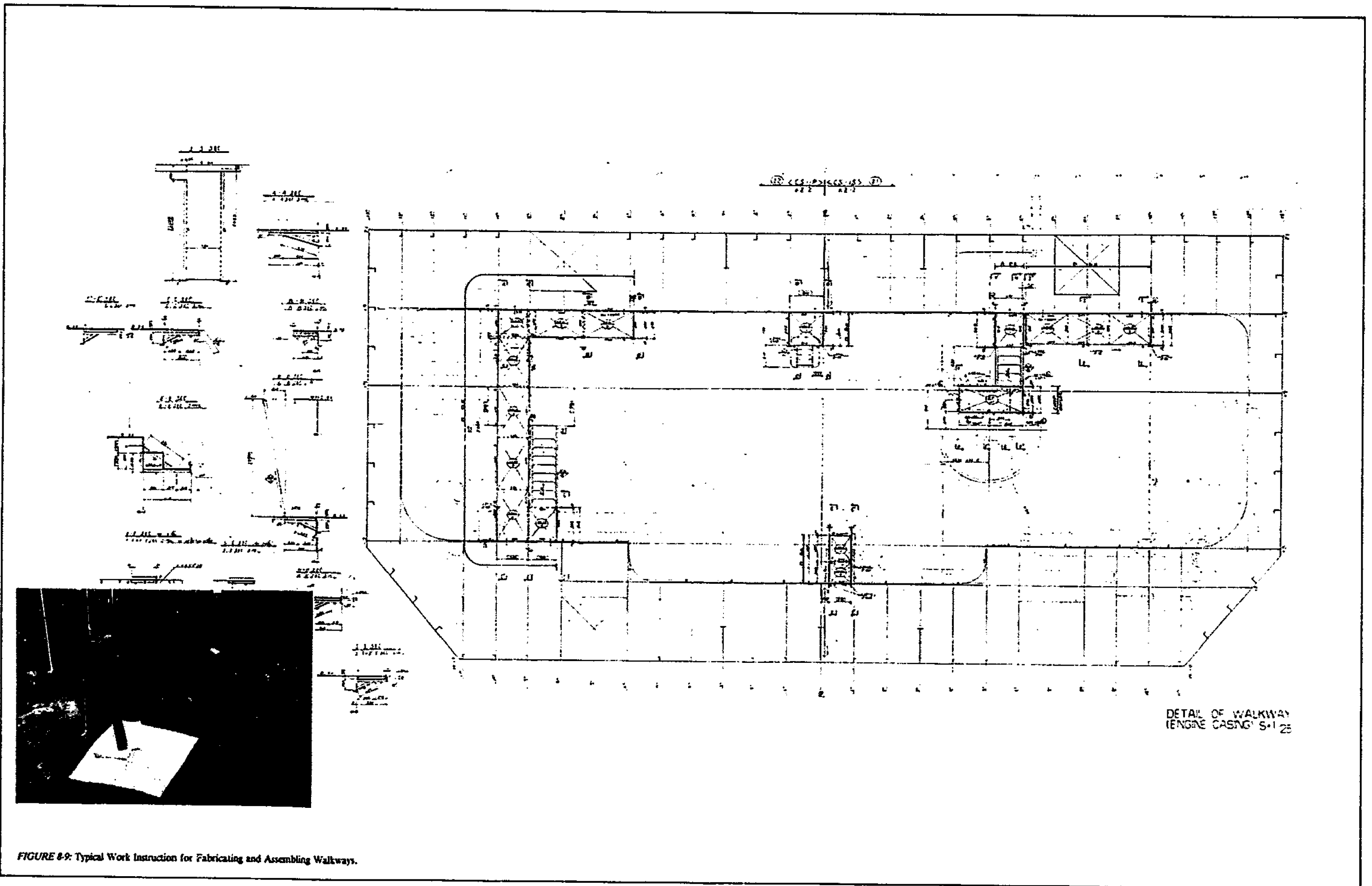

FIGURE 8-9: Typical Work Instruction for Fabricating and Assembling Walkways.

S.NO.5607

MANUFACTURING LIST OF LADDER

ENG. ROOM

| LADDER No. | INSTALL. AREA | APPLIED STD. SYMBOL | REQ'D | DIMENSION | | | | | | | | |
|---------------|------------------|------------------------|-------|-----------|------|------|------|-----|-----|-----|-------|--|
| | | | | H | L | A | ANG. | P | P1 | P2 | STP . | |
| FLH001 | KF2 | KLA 600 | 1 | 2715 | 3015 | 1855 | 55 | 250 | 250 | 215 | 1.0 | |
| FLH002 | KF2 | KLA 600 | 1 | 2365 | 2588 | 1610 | 55 | 250 | 200 | 165 | 9 | |
| FLH003 | KF2 | KLA 600 | 1 | 620 | 458 | 390 | 55 | 250 | 190 | 180 | 2 | |
| FLH004 | KF2 | KLA 600 | 1 | 545 | 366 | 335 | 55 | 0 | 275 | 270 | 1 | |
| FLH005 | KF2 | KLA 600 | 1 | 650 | 494 | 410 | 55 | 250 | 200 | 200 | 2 | |
| FLH006 | KF2 | KLA 600 | 1 | 650 | 494 | 410 | 55 | 250 | 200 | 200 | 2 | |
| FLH007 | KF2 | KLA 600 | 1 | 820 | 702 | 530 | 55 | 250 | 300 | 270 | 2 | |

FIGURE 8-II: Typical Manufacturing List for Ladders.

8.2.4 Tanks

There are two types of tanks, i.e., integral with hull structure and independent. The former is necessarily incorporated as part of hull-block assembly. Details of connecting pipe pieces, nozzles, etc. are produced as described for outfitting on-block. Fabrication drawings for independent tanks, typically shown in Figure 8-12, are made per dimensions obtained from tank models. As for other fabrication drawings, an on-unit or on-block outfitting stage must be designated.

8.2.5 Ventilation Ducts

Drawing for ventilation-duct runs may be:

- superimposed on composites in sufficient detail so that separate fabrication drawings can be prepared for each duct piece, or
- a separate drawing, as shown in Figure 8-13, for both fabrication and assembly of a portion of a ventilation-duct run.

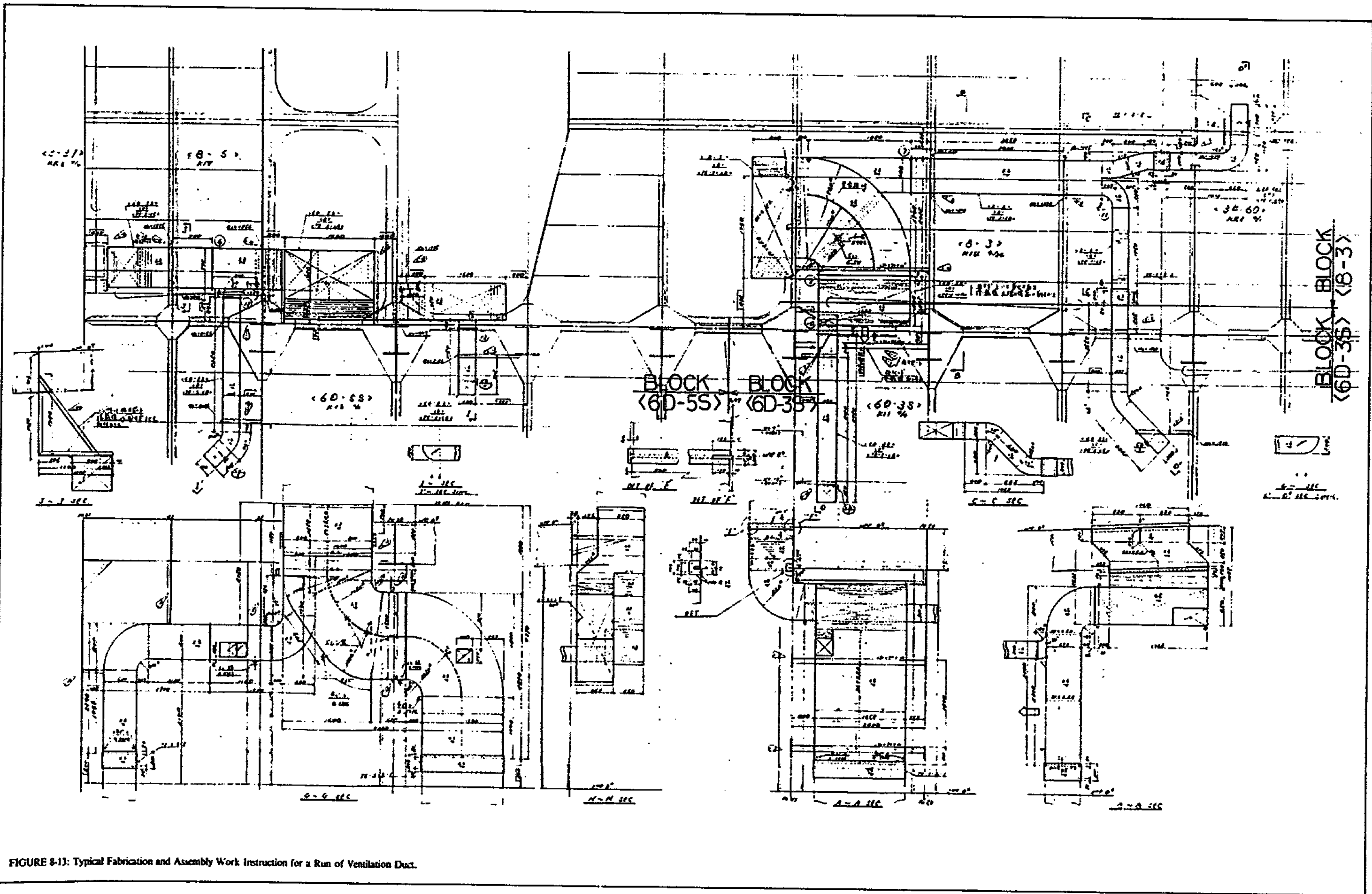

FIGURE 8-13: Typical Fabrication and Assembly Work Instruction for a Run of Ventilation Duct.

9.0 MODEL SHOP FACILITIES AND REQUIREMENTS

9.1 Location and Space

A model shop should be located near the room assigned for outfit-design. This close proximity is needed because design phases are intentionally overlapped and designers have need to constantly interact with both design modeling and drawing processes. Although close, distinct separation is required because of noise and dust associated with modeling work. Depending on a yard's shipbuilding capacity, the space allocated for a model shop should permit 6 to 15 hull-block models to be assembled simultaneously.

9.2 Conditions for Modeling Work

9.2.1 Environment

In order to prevent plastic materials from sagging and also for the comfort of design modelers, the model shop should be air conditioned and kept at about 25-degrees Centigrade. Lighting should be equivalent to that provided for conventional drafting, i.e., about 500 lux. Adequate ventilation is required as sawing and joining processes for plastics produce toxic gases. Provision must also be made for dust collection.

9.2.2 Furniture, Equipment and Tools

A typical model-shop arrangement is shown in Figure 9-1. The furniture required includes cabinets and wood-top work tables as illustrated in Figure 9-2. The furniture should be supplemented with fire extinguishers, photographic equipment, trash cans, etc.

Safe, efficient and effective machine tools are important as, in addition to use by experienced modelers, they could be operated by people who have primarily design or some other expertise. Typical machine tools for model shops include, large and small circular and band saws, and a circular-saw cutter, planer, belt sander, combination bench grinder and buffer, and drill press. See Figure 9-3.

Typical other tools required include:

- bench vises (large and small),
- hacksaws (large and small),
- C-clamps,
- surface gages,
- vernier calipers,
- steel rules,
- steel tapes,

- squares,
- inside and outside calipers,
- protractors,
- screwdrivers,
- adjustable wrenches,
- side-cutting pliers,
- needle-nose pliers,
- chisels,
- hammers,
- wood mallets,
- planes,
- scissors,
- knives,
- files,
- cast-iron weights,
- levels,
- whetstones,
- nail pullers,
- drills, and
- wire brushes.

1 Miscellaneous equipment and supplies needed include:

- face masks,
- goggles,
- syringes for applying adhesives,
- adhesives,
- "Dymo" tapewriter,
- sandpaper,
- adhesive tape (one-side and double-side)
- pens and quick-drying ink.

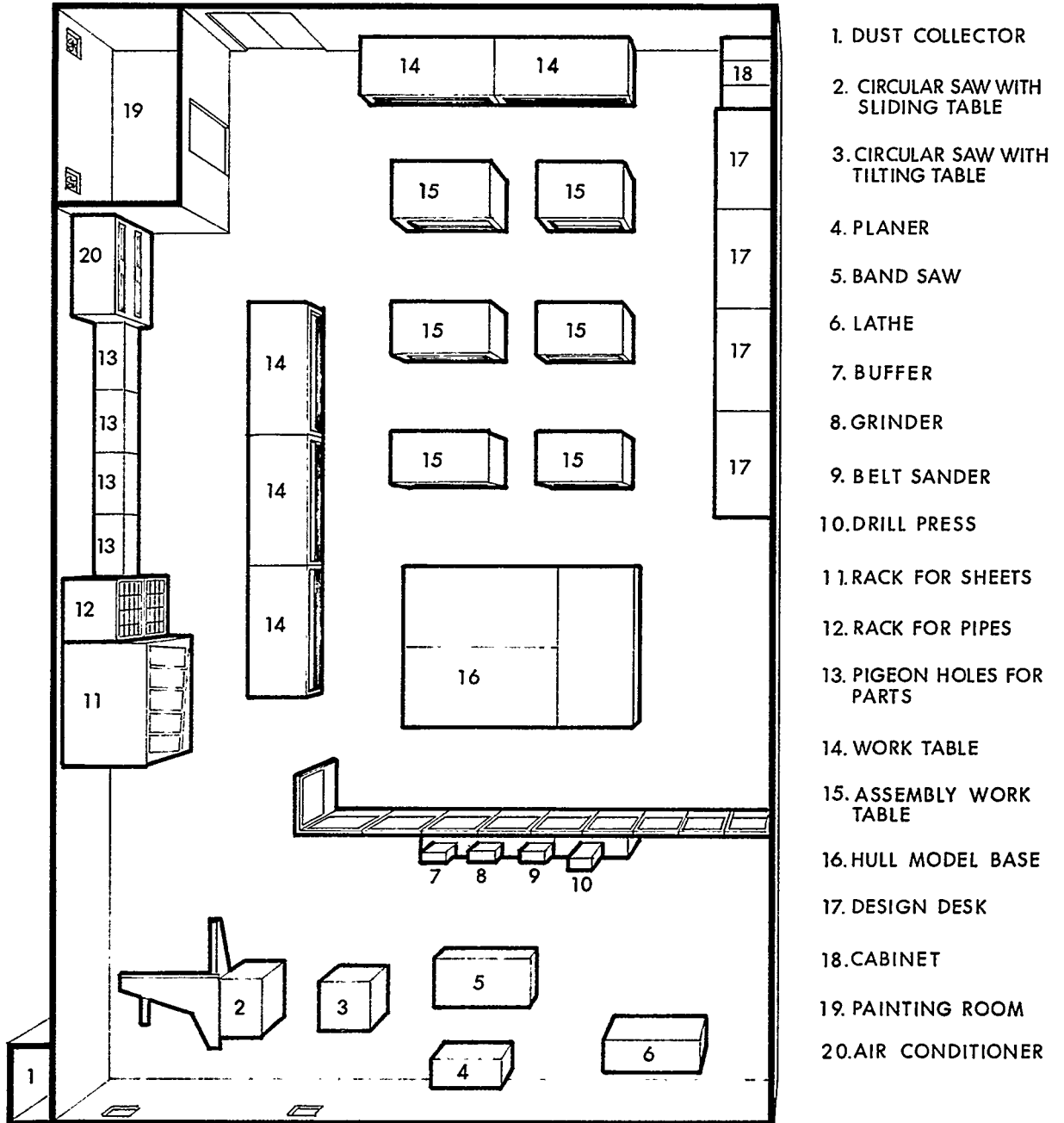

FIGURE 9-1: Typical Model-Shop Arrangement.

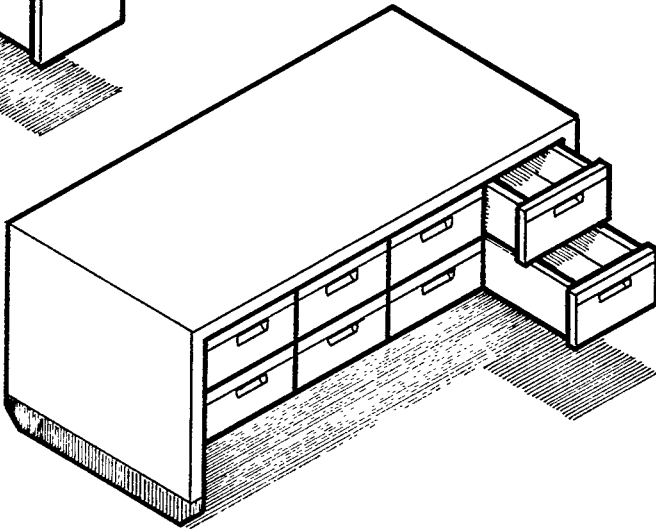
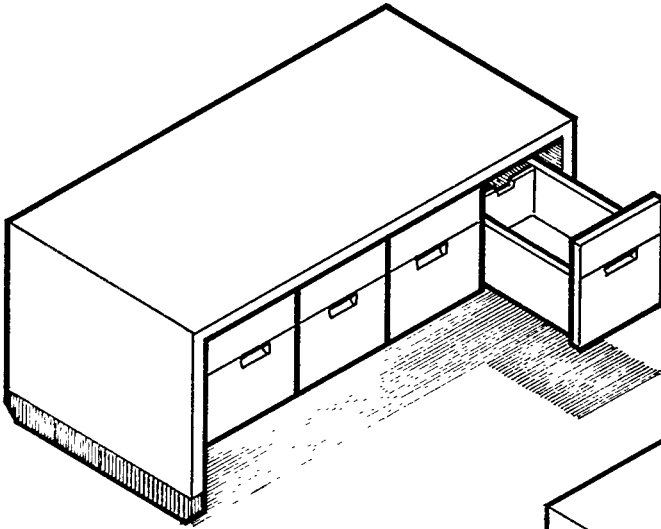
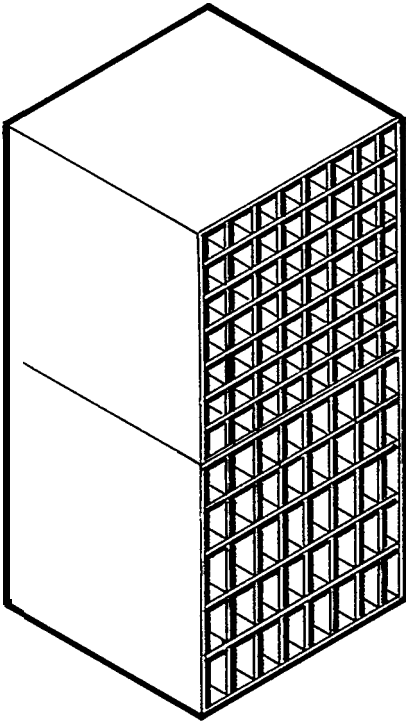
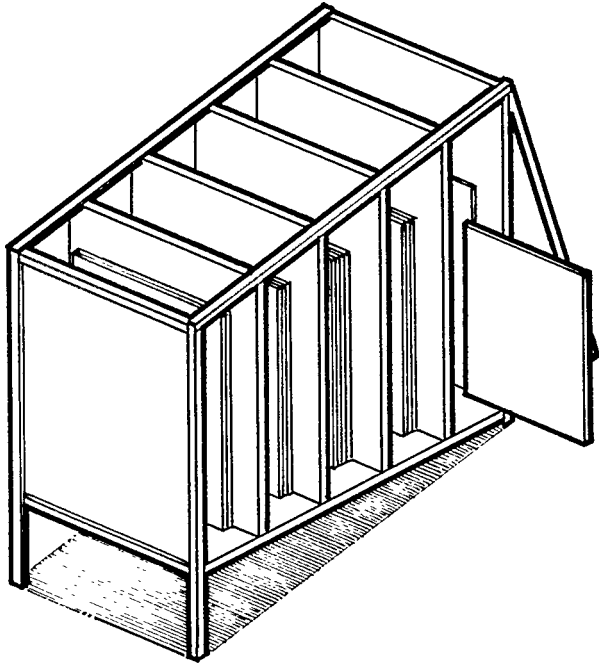
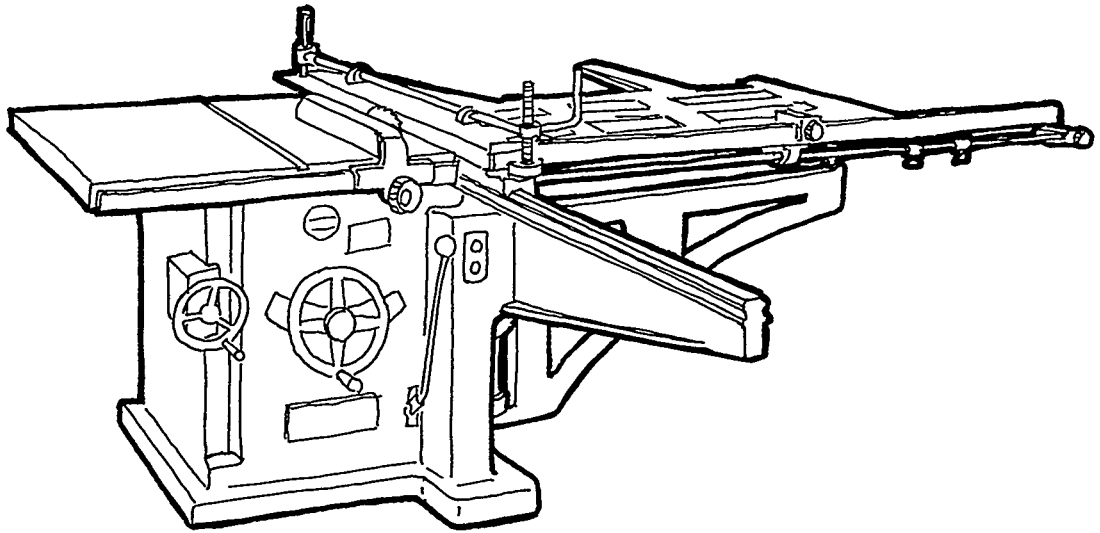
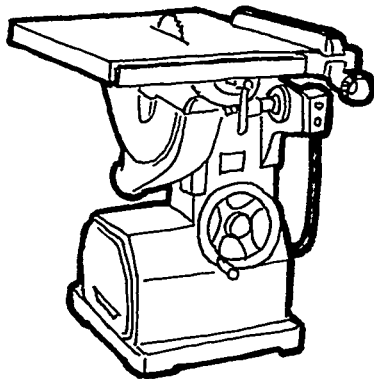

FIGURE 9-2: Sheet-Material and Pigeon-Hole Cabinets and Work Tables.

CIRCULAR SAW WITH SLIDING TABLE



CIRCULAR SAW WITH TILTING TABLE



MITER CUTTER

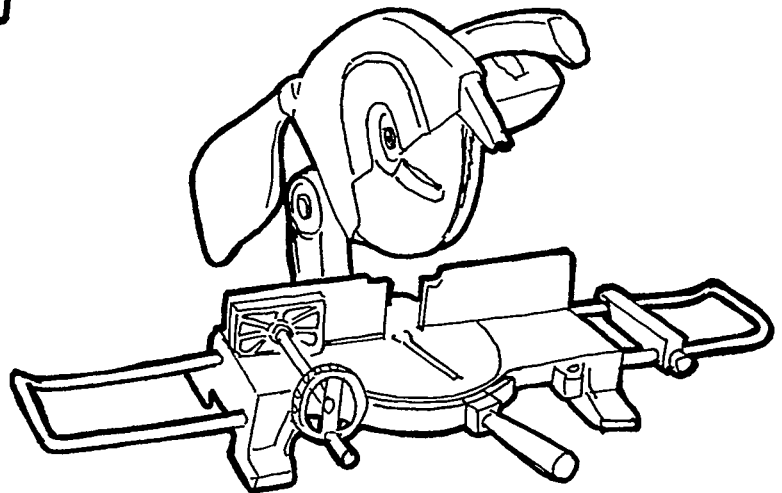

FIGURE 9-3: Typical Machine Tools.

10.0 DESIGN MODELING FOR OTHER THAN SHIPS

Figures 10-1 through 10-5 show various aspects of design-model sections for a phosphoric-acid and by-products plant constructed by Hitachi Zosen (Shipbuilding) Corporation.

The design model was made in accordance with process-data sheets, mechanical-data sheets, arrangement plans and other reference drawings to achieve a plant that is safe, economical, and easy to operate and maintain. Further, the model was also intended to be used for education and training of the customer's people. Immediately after use for creative design purposes, the model was transported to the construction site where it was widely used to facilitate scheduling discussions and to plan post-delivery maintenance procedures.

The model was built to 1:30 scale, had 52 separate bases (each 1.5 by 0.75 meters), and occupied a total area of about 60 square meters. Approximately 7,000 man-hours were required for structures, platforms and machinery and about 13,000 for assembling piping and electric-cable runs. The number of man-hours required for such design modeling is relatively high compared to that for a ship's engine-room because the design of large industrial plants entails much more design alteration and modification of details.

Usually for a large industrial plant, an overall layout model is made to 1:1,000 scale see Figure 10-6.

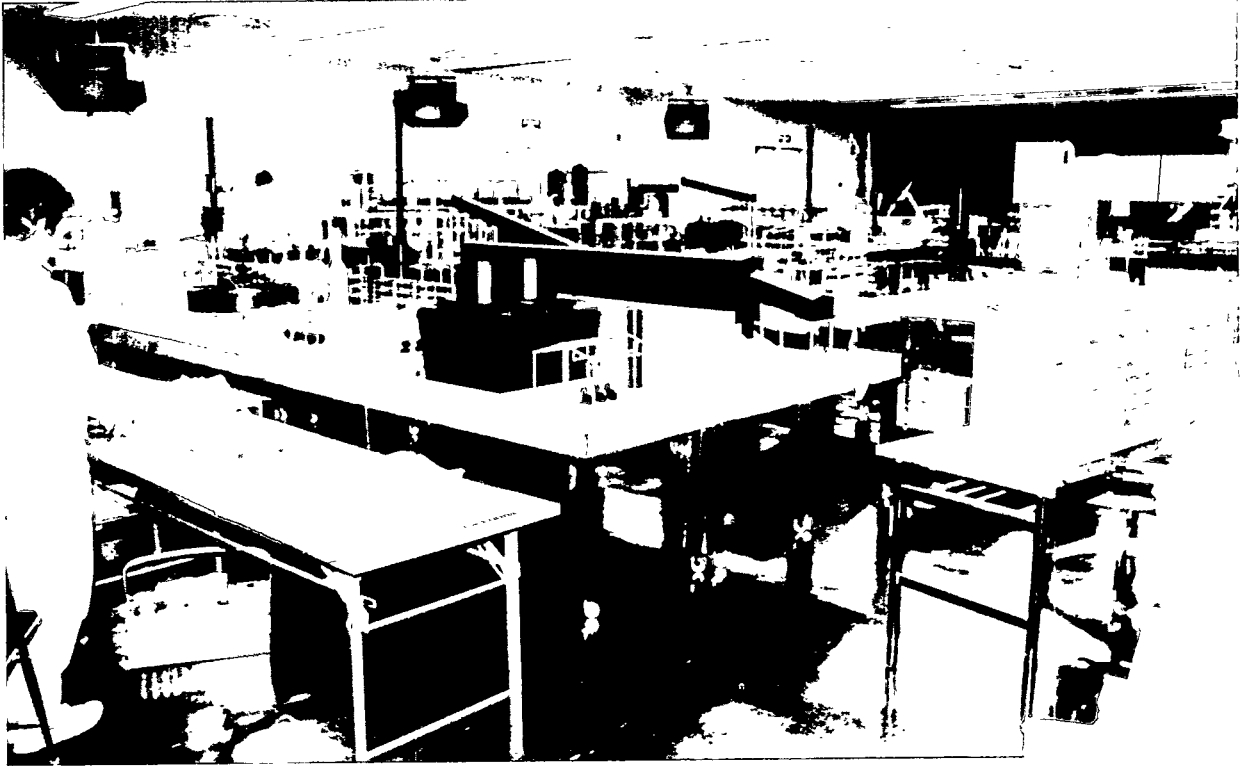

FIGURE 10-1: Design-Model Sections for a Chemical Plant.

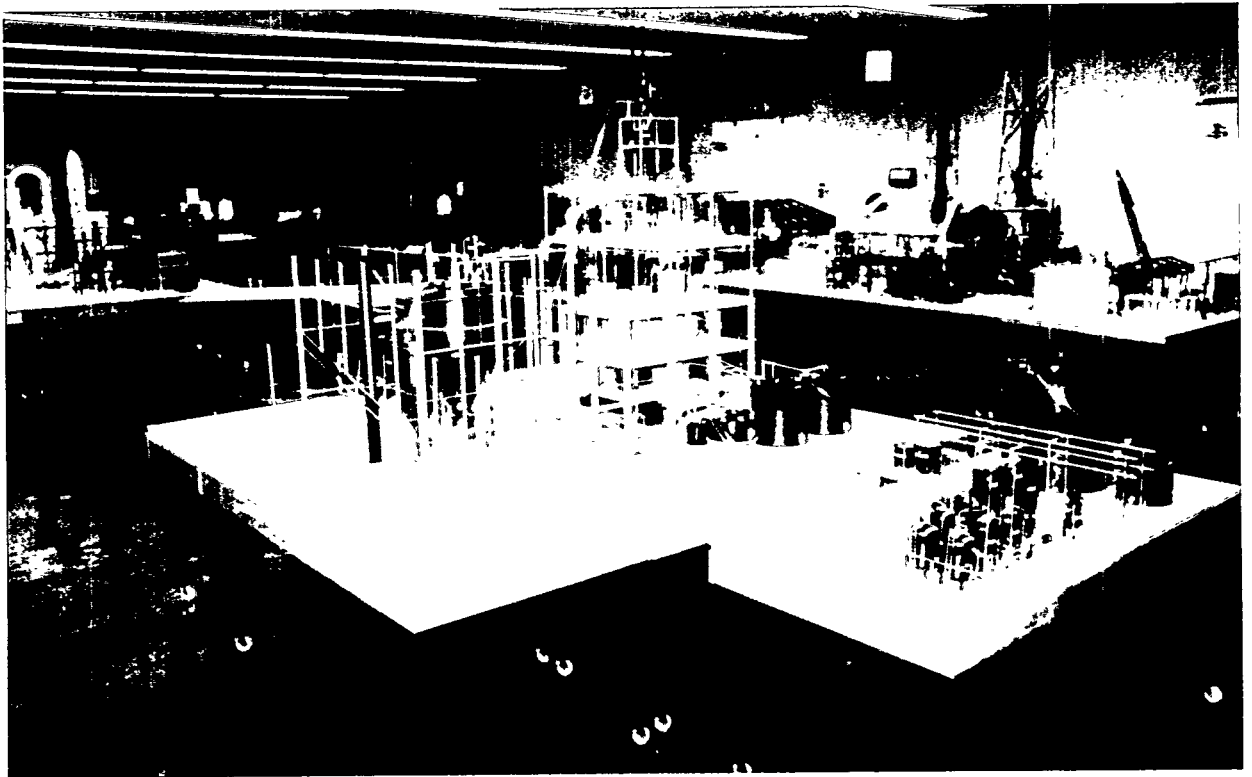

FIGURE 10-2: Design-Model Sections for a Chemical Plant.

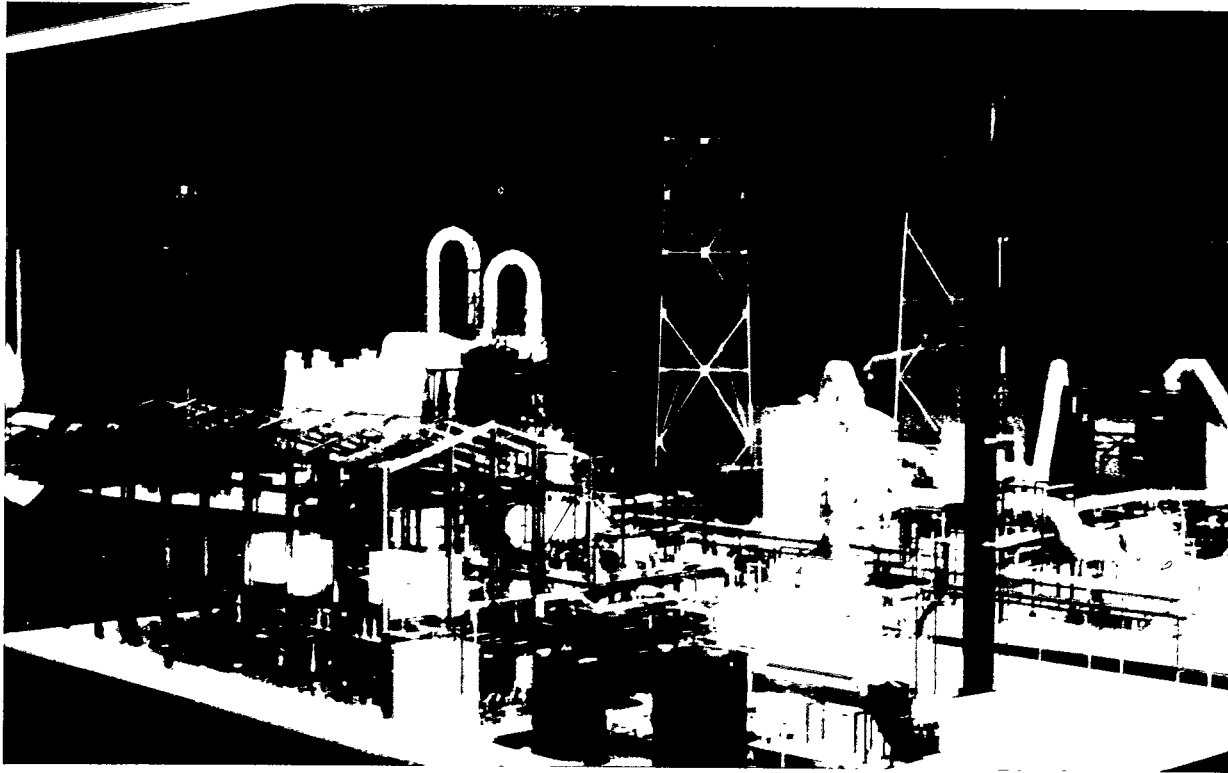

FIGURE 10-3: Design-Model Sections for a Chemical Plant.

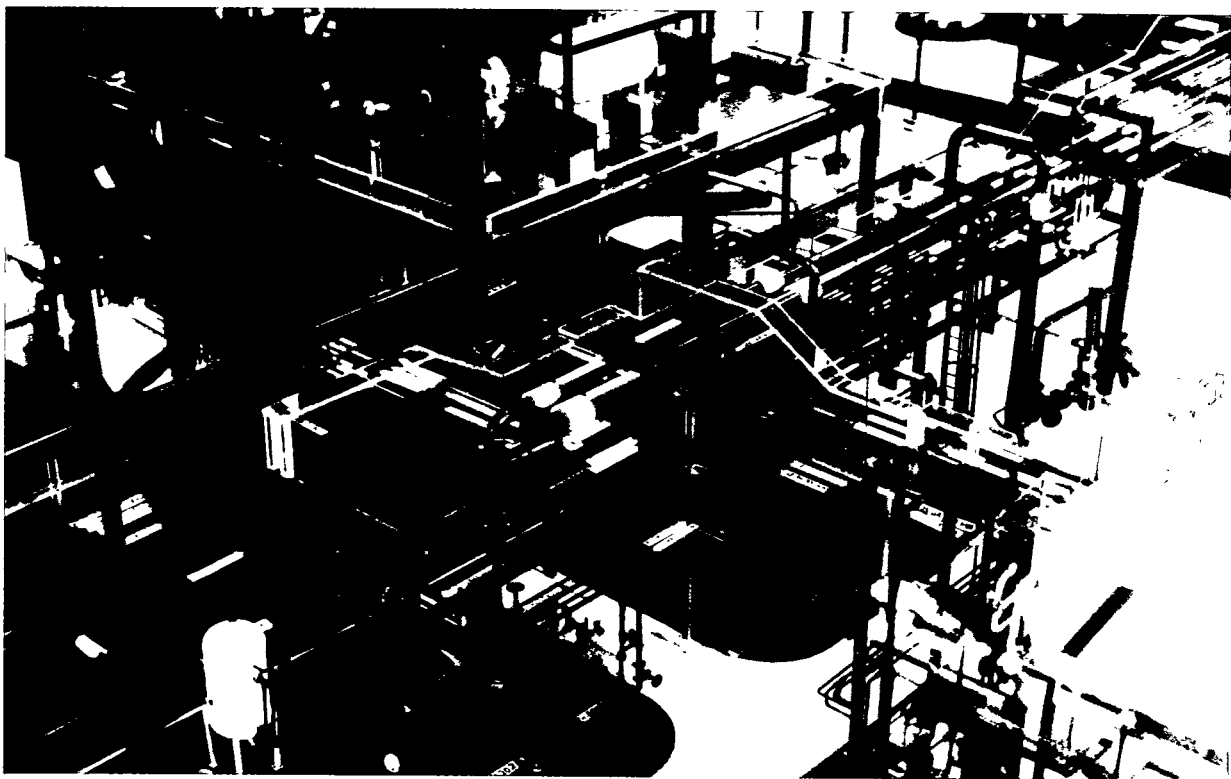

FIGURE 10-4: Details of a Chemical-Plant Design-Model.

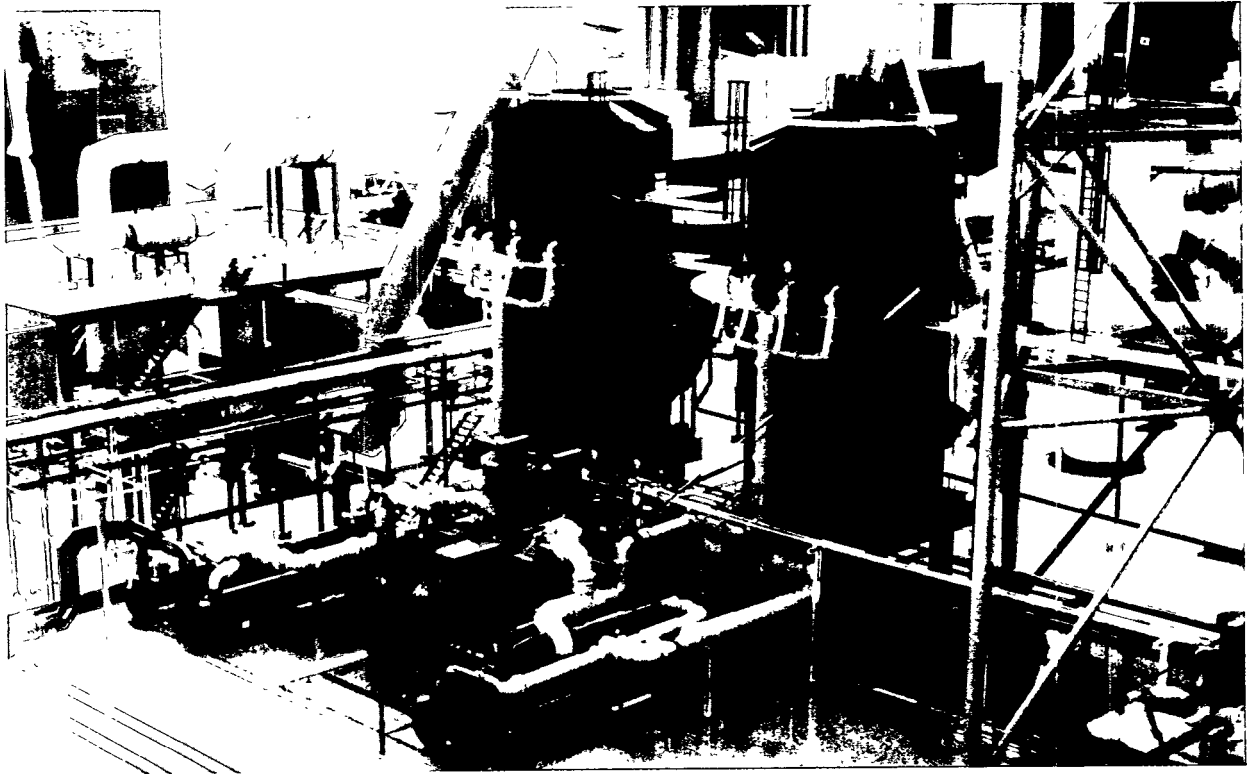

FIGURE 10-5: Details of a Chemical-Plant Design-Model.

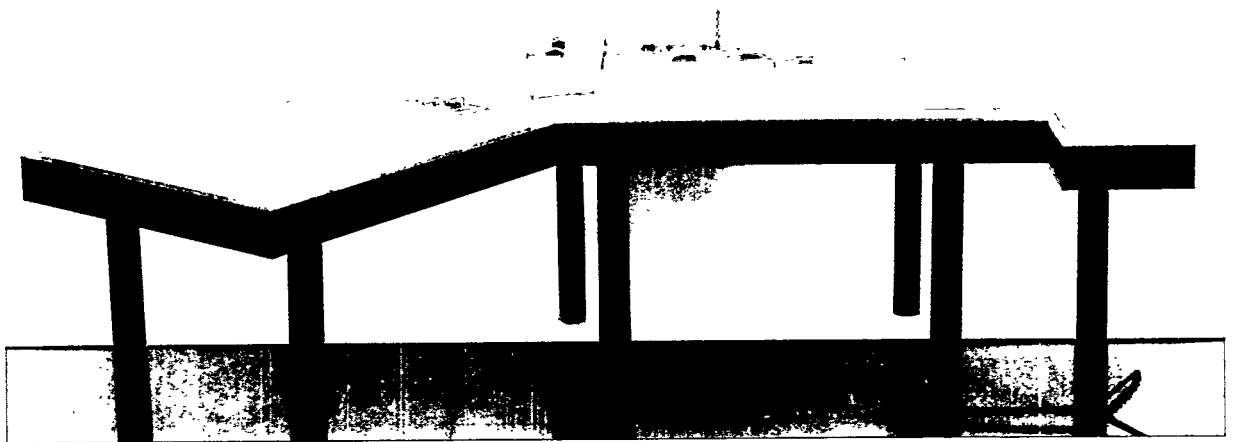

FIGURE 10-6: Layout Model for a Chemical Plant. Scale 1:1,000.