

**THE NATIONAL
SHIPBUILDING
RESEARCH PROGRAM**

**EVALUATION OF
THE USABILITY AND BENEFITS OF
TWIST WIRE GMAW AND FACW NARROW
GAP WELDING**

U.S. DEPARTMENT OF TRANSPORTATION MARITIME ADMINISTRATION
IN COOPERATION WITH PUGET SOUND NAVAL SHIPYARD, INGALLS
SHIPBUILDING, INC., AND NEWPORT NEWS SHIPBUILDING AND
DRYDOCK COMPANY

Report Documentation Page

*Form Approved
OMB No. 0704-0188*

Public reporting burden for the collection of information is estimated to average 1 hour per response, including the time for reviewing instructions, searching existing data sources, gathering and maintaining the data needed, and completing and reviewing the collection of information. Send comments regarding this burden estimate or any other aspect of this collection of information, including suggestions for reducing this burden, to Washington Headquarters Services, Directorate for Information Operations and Reports, 1215 Jefferson Davis Highway, Suite 1204, Arlington VA 22202-4302. Respondents should be aware that notwithstanding any other provision of law, no person shall be subject to a penalty for failing to comply with a collection of information if it does not display a currently valid OMB control number.

1. REPORT DATE 1985	2. REPORT TYPE	3. DATES COVERED 00-00-1985 to 00-00-1985	
4. TITLE AND SUBTITLE The National Shipbuilding Research Program. Evaluation of the Usability and Benefits of Twist Wire GMAW and FACW Narrow Gap Welding		5a. CONTRACT NUMBER	
		5b. GRANT NUMBER	
		5c. PROGRAM ELEMENT NUMBER	
6. AUTHOR(S)		5d. PROJECT NUMBER	
		5e. TASK NUMBER	
		5f. WORK UNIT NUMBER	
7. PERFORMING ORGANIZATION NAME(S) AND ADDRESS(ES) Naval Surface Warfare Center CD, Code 2230 -Design Integration Tower, 9500 MacArthur Blvd Bldg 192 Room 128, Bethesda, MD, 20817-5700		8. PERFORMING ORGANIZATION REPORT NUMBER	
9. SPONSORING/MONITORING AGENCY NAME(S) AND ADDRESS(ES)		10. SPONSOR/MONITOR'S ACRONYM(S)	
		11. SPONSOR/MONITOR'S REPORT NUMBER(S)	
12. DISTRIBUTION/AVAILABILITY STATEMENT Approved for public release; distribution unlimited			
13. SUPPLEMENTARY NOTES			
14. ABSTRACT			
15. SUBJECT TERMS			
16. SECURITY CLASSIFICATION OF:			17. LIMITATION OF ABSTRACT
a. REPORT unclassified	b. ABSTRACT unclassified	c. THIS PAGE unclassified	
			18. NUMBER OF PAGES 79
			19a. NAME OF RESPONSIBLE PERSON

**THE NATIONAL
SHIPBUILDING
RESEARCH PROGRAM**

**EVALUATION OF
THE USABILITY AND BENEFITS OF
TWIST WIRE GMAW AND FACW NARROW
GAP WELDING**

**U.S. DEPARTMENT OF TRANSPORTATION MARITIME ADMINISTRATION
IN COOPERATION WITH PUGET SOUND NAVAL SHIPYARD, INGALLS
SHIPBUILDING, INC., AND NEWPORT NEWS SHIPBUILDING AND
DRYDOCK COMPANY**

DISCLAIMER

This report was prepared as an account of government-sponsored work. Neither the United States, nor the Maritime Administration, nor any person acting on behalf of the Maritime Administration (A) makes any warranty or representation, expressed or implied, with respect to the accuracy, completeness or usefulness of the information contained in this report/manual, or that the use of any information, apparatus, method, or process disclosed in this report may not infringe privately owned rights; or (B) assumes any liabilities with respect to the use of or for damages resulting from the use of any information, apparatus, method, or process disclosed in the report. As used in the above, "Persons acting on behalf of the Maritime Administration" includes any employee, contractor, or subcontractor to the contractor of the Maritime Administration to the extent that such employee, contractor, or subcontractor to the contractor prepares, handles, or distributes, or provides access to any information pursuant to his employment or contract or subcontract to the contractor with the Maritime Administration. ANY POSSIBLE IMPLIED WARRANTIES OF MERCHANTABILITY AND/OR FITNESS FOR PURPOSE ARE SPECIFICALLY DISCLAIMED.

FOREWORD

This report presents the results of a project initiated by SP-7, the Welding R&D panel of the Ship Production Committee of the Society of Naval Architects and Marine Engineers. The project was financed through a cost sharing contract between the U.S. Maritime Administration, Puget Sound Naval Shipyard, Newport News Shipbuilding and Drydock Corporation and Ingalls Shipbuilding, Incorporated. The principle objective was to evaluate the application of twisted wire Gas Metal Arc and Flux Cored arc welding of plates with Narrow Gap fit-ups to minimize welding.

The project was conducted under the SP-7 panel Chairmanship of Ben Howser of Newport News Shipbuilding and Drydock Corporation and Lee Kvidahl of Ingalls Shipbuilding, Inc. and the Program Management of Mark Tanner of NNS and O. J. Davis of Ingalls Shipbuilding, Inc.

The project was carried out by the Welding Engineering group of Puget Sound Naval Shipyard under the leadership of Douglas Coglizer, Head of the Welding Engineering Division and Frank Gatto, Head, Piping, Machinery, and Pressure Vessel Branch and member of the SP-7 Panel. The report was prepared by Derek Mortvedt of Puget Sound Naval Shipyard.

EXECUTIVE SUMMARY

Butt welding of thick plates with narrow gap fit-ups in lieu of conventional U-groove and V-bevel angles is recognized as one approach to reducing the time and cost of welding in shipbuilding. The use of multiple twisted filler wires as electrodes is found to overcome some of the problems of lack of side wall fusion and slag entrapment associated with single wire arc welding of narrow gap butt welds.

To date there are numerous articles written which show a tremendous potential cost savings of various narrow gap welding processes including twist wire welding. These articles very adequately address other important productivity factors such as a comparison of reduced joint geometry, arc time, deposition rate and mechanical properties. No attempt is made in this report to verify or duplicate these issues.

The main objectives of this project are:

- a) Identify known problems which have caused other narrow gap processes to be nonproductive as well as new problems unique to the twist wire process or the shipbuilding industry.
- b) Identify the welding conditions that cause these problems so that the operating range which provides defect free welds can be identified.
- c) Once the operating range is known, evaluate whether this range will be adequate to provide cost effective welds in the non-optimum conditions found in the shipbuilding industry.

The problems causing narrow gap processes to fail are:

- a) Solidification cracking
- b) Lack of sidewall fusion
- c) Lack of fusion between two weld beads
- d) Undercut of the sidewall
- e) Equipment problems.

The cause of these problems are the inability of narrow gap processes to operate outside a set of conditions easily maintained in lab testing but which are unrealistic for production welding:

- a) Close joint fitup tolerance
- b) Narrow welding parameter range
- c) Precise electrode positioning
- d) Easily lost shielding gas
- e) Inability to repair visual defects
- f) Inability to weld over stops and starts
- g) Arcing the contact tip against the sidewall
- h) Complicated, expensive equipment which does not hold up.

To evaluate various wire sizes a wire twister was developed to produce limited quantities for testing. This testing concluded that only specific wire sizes will reliably produce defect free welds in a production environment.

Having a wire twisting machine resulted in two major unexpected benefits. First, invaluable lessons were learned about wire quality requirements. The two major problems with wire quality are helix and wrapping. Helix in the wire well causes the wire to wander in the joint after leaving the contact tip. If one wire is intermittently wrapped around the other rather than being equally intertwisted the resulting change in overall diameter hesitates or even stops in the feed coise or contact tip. The second major spin-off was the ability to develop the flux cored twist wire process which was found to be even more forgiving in a production environment than solid twist wire.

CONCLUSIONS

Welding parameters for both twisted solid wire (2mm) and twisted flux-core (3/32") have been developed on up to 3" thick plate. Significant improvements in welding productivity have been achieved by use of the process.

TABLE OF CONTENTS

	Page
1. Introduction	1
2. Weld Defects and Causes	2
2.1. Lack of Sidewall Fusion	2
2.1.1. Bead Shape	3
2.1.2. Bead Surface	3
2.2. Solidification Cracking	4
2.2.1. Depth-to-Width Ratio Versus Gap Width	5
2.2.2. Depth-to-Width Ratio Versus Amperage	5
2.3. Effects of Travel Speed	6
2.3.1. Solidification Cracking Versus Travel Speed	6
2.3.2. Lack of Fusion Versus Travel Speed	7
2.3.3. Undercut Versus Travel Speed	8
3. Equipment	9
3.1. Wire Twister and Wire Quality	9
3.2. Welding Equipment	11
4. Useability	13
4.1. Useability of Process	13
4.1.1. Definition	13
4.1.2. Evaluation Method	14
4.1.3. Wire Size and Type	17
4.1.3.1. Conclusions on Wire Size and Type	17
4.1.4. Parameter Ranges	19
4.1.5. Electrode Centering Tolerance	22
4.1.6. Welding over Sidewall Defects	22
4.1.7. Joint Design	23
4.2. Useability of Welding Equipment	25
4.2.1. Welding of 20 foot Plate	25
4.2.2. Kobe System	27
4.2.3. Vision System	27
5. Conclusions	28
6. List of References	30
7. Charts	
I. Usable Range of Amperage and Gap Width for 2x1/16" Solid Electrode	31
II. Usable Range of Amperage and Gap Width for 2x2mm Solid Electrode	32
III. Usable Range of Amperage and Gap Width for 2x1/16" Flux Cored Electrode	33
IV. Usable Range of Amperage and Gap Width for 2x3/32" Flux Cored Electrode	34
V. Effects of Travel Speed for 2x2mm Solid Electrode	35

TABLE OF CONTENTS (Continued)

	Page
VI. Effects of Travel Speed for 2x3/32" Flux Cored Electrode	36
VII. Effects of Voltage for 2x3/32" Flux Cored Electrode	37
 List of Figures	
1. Arc Deflections	2
2. Bead Shape	3
3. Bead Surface	4
4. Bead Width	4
5. Depth/Width Ratio Versus Gap Width	5
6. Depth/Width Ratio Versus Amperage	6
7. Solidification Pattern of Bead Surface Versus Travel Speed	7
8. Slow Travel Speed as Cause of Slag Inclusions	8
9. Methods for Measuring Degree of Wire Wrapping	11
10. Schematic of Weld Test Plate	14
11. Measurement of Electrode Offset	22
12. Joint Design	24
 List of Tables	
I. Summary of Defect Types and Causes	15
II. Comparison of Two Usable Twist Wire Electrodes	19
III. 2x5/64" Solid Wire Electrode, Fit-up and Welding Parameters	20
IV. 2x3/32" Flux Cored Electrode Fit-up and Welding Parameters	21
 Photographs	
1. First Prototype PSNS Wire Twister	38
2. Second Prototype PSNS Wire Twister	39
3. Tension Equalizer	40
4. Cross Sections of 2x1/16" Solid Electrode Welds	41
5. Cross Sections of 2x2mm Solid Electrode Welds	42
6. Cross Sections of 2x1/16" Flux Core Welds	43
7. Cross Sections of 2x3/32" Flux Core Welds	44
8. Wrapping Defects in 2x3/32" Flux Cored Electrode	45
9. Macros of Completed Narrow Gap Joints	46
10. Welding Over Centerline Cracks with the 2x2mm Solid Electrode	47
11. Crack-free 2x3/32" Flux Core Weld in a 20° Bevel	48
12. 2x3/32" Flux Core Weld in a 45° Bevel, 2" Plate	49
13. 2x3/32" Flux Core Weld in a 35° Bevel, 2" Plate	50
14. Contact Tip Life Versus Size of Threaded Connection	51
15. Thicker Torch to Accommodate Larger Contact Tip Threads	52
pendix I. Welding Procedure Qualification/Test Data	A-I
pendix II. Flux Cored Twist Wire Weld Procedure Specification For Manganese Molybdenum Tanks and Joint Designs	A-II
pendix III. KOBE TW-1 Equipment	A-III

1. Introduction.

Puget Sound Naval Shipyard has evaluated twist wire narrow gap welding for applications in the shipbuilding industry. This evaluation was accomplished for the Ship Production Committee Welding Panel, SP-7, of the National Shipbuilding Research Program. The work has included the evaluation of both twist solid electrode and twist flux cored electrode. At the present time there is no routine, satisfactory welding technique in use in the United States for narrow gap welding of 1" to 3" thick marine steels. As compared to what could be achieved with twist wire narrow gap welding, the conventional welding processes in use today require large amounts of flame cutting for joint preparation, longer arc times, more filler metal and result in greater weld distortion. Currently heavy fabricated metal for ship hulls, decks, inserts, foundations, etc. requires large bevel angles for equipment access and electrode manipulation to obtain high quality welds.

2. Weld Defects And Causes.

2.1. Lack Of Sidewall Fusion. To evaluate the useability of the twist wire welding process it is first important to understand the causes of weld defects which are unique to one pass per layer narrow gap welding. As expected with the narrow gap joint configuration, a major problem is lack of sidewall fusion. The twist wire process eliminates lack of fusion by using magnetic arc deflections and arc rotation to direct the arc force more toward the joint sidewalls. Figure 1 schematically shows how the arc is alternately generated from two solid wires of the conventional twist wire process and the resulting intermittent arc rotation. Arc stabilizers in flux cored twist wire allows an arc to be generated from both wires at all times resulting in continuous arc rotation and a dramatically lower weld bead depth-to-width ratio D/W.

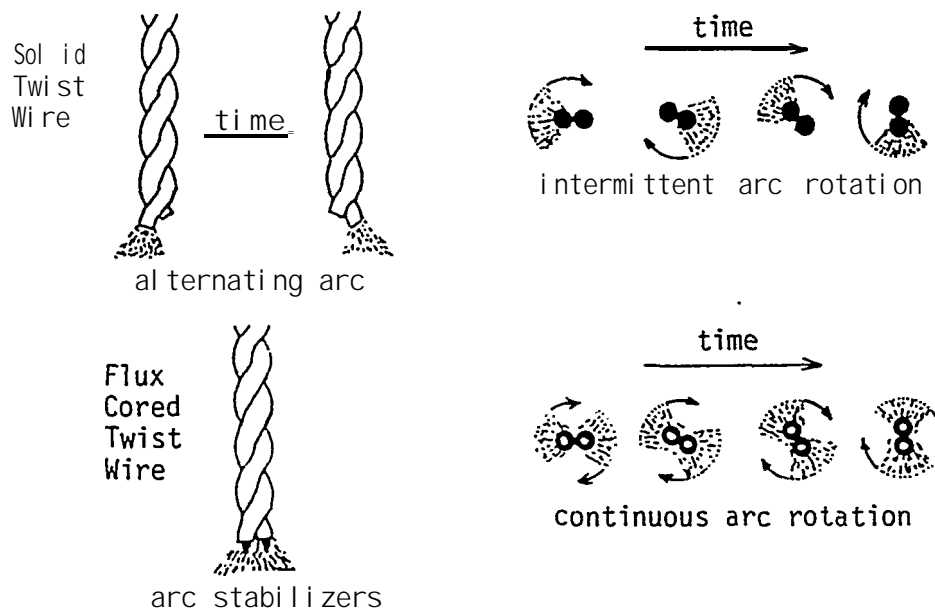

Figure 1. Arc deflections

2.1.1. Bead Shape. The weld cross sectional bead shape is a very important factor to consider in eliminating sidewall lack of fusion. Figure 2 shows how a more uniform bead shape eliminates lack of fusion. The desired bead shape of Figure 2b, as achieved by the twist wire welding process, has a deeper sidewall penetration throughout the weld cross section and a more uniform penetration depth-wise than the bead shape of Figure 2a for single wire GMAW narrow gap welding. Even if the bead shape of Figure 2a has a greater penetration in the location W, the bead shape of Figure 2b is more desirable since it eliminates lack of fusion by increasing the sidewall penetration in the critical location W_1 .

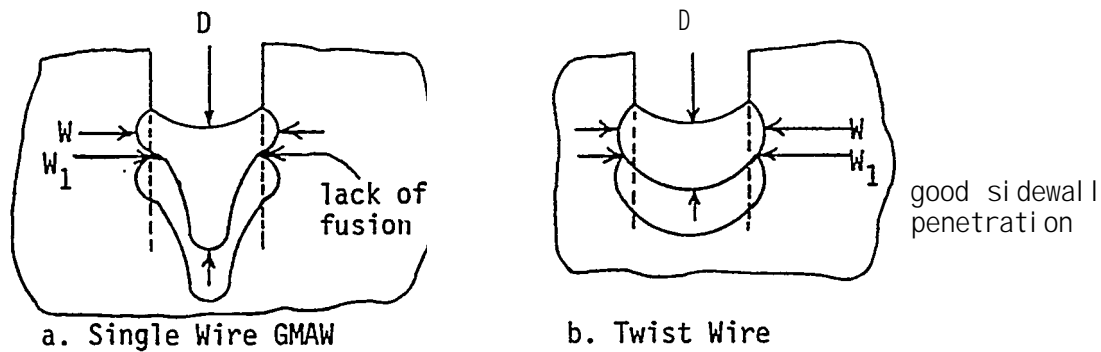

Figure 2. Bead shape

2.1.2. Bead Surface. A concave bead surface is also necessary to eliminate lack of fusion at the weld joint interface of the subsequent weld layer. Once the proper cross-sectional bead shape of Figure 2b is obtained, developing the flat at bead surface of Figure 3b by increasing the gap width becomes the factor which limits how wide the gap width G can be. The flat bead surface of Figure 3b will cause lack of sidewall fusion at the bottom of the next weld bead.

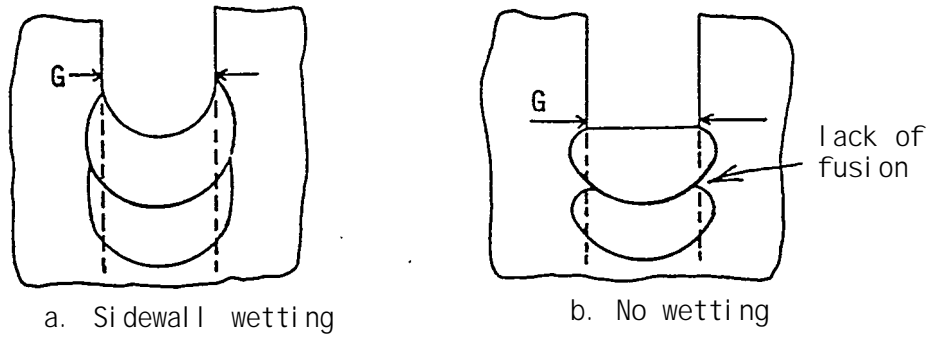

Figure 3. Bead surface

2.2. Solidification Cracking. Figure 4 shows the relationship between solidification cracking and the depth-to-width ratio D/W of mild steel weld beads deposited under the high restraint conditions of narrow gap welds in thick plate.

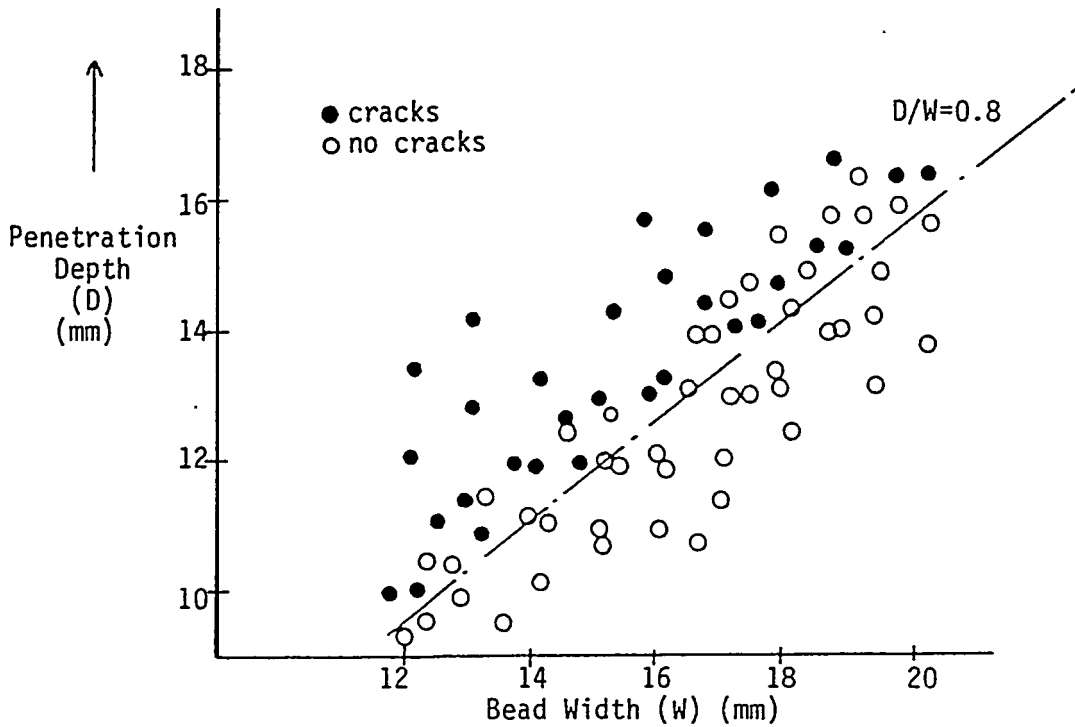

Figure 4¹. Conditions causing solidification cracking

Figure 4 shows that when D/W is greater than 0.8 there is a high chance of solidification cracking. Experience has shown that when the base material or

¹ref. 2

filler metal is manganese molybdenum or in general has a higher carbon equivalent than mild steel, solidification cracking may occur at a lower D/W ratio. On the other hand, when twist MIL-100S-1 electrode (Mn, Ni, MO) is used or when a plate with less restraint is welded the D/W ratio can be higher without cracking. For the sake of analysis, 0.8 was used as the maximum acceptable D/W ratio with the understanding that this value may need to be adjusted for the specific material type and weld restraint conditions.

2.2.1. Depth-to-Width Ratio Versus Gap Width. The dendritic grain growth and segregation pattern versus the gap width is shown in Figure 5. Obviously, the D/W ratio becomes higher as the gap width G reaches the narrow end of the acceptable gap width range. D/W = 0.8 is therefore the criteria that is used to determine the minimum gap width that can be welded without centerline cracking.

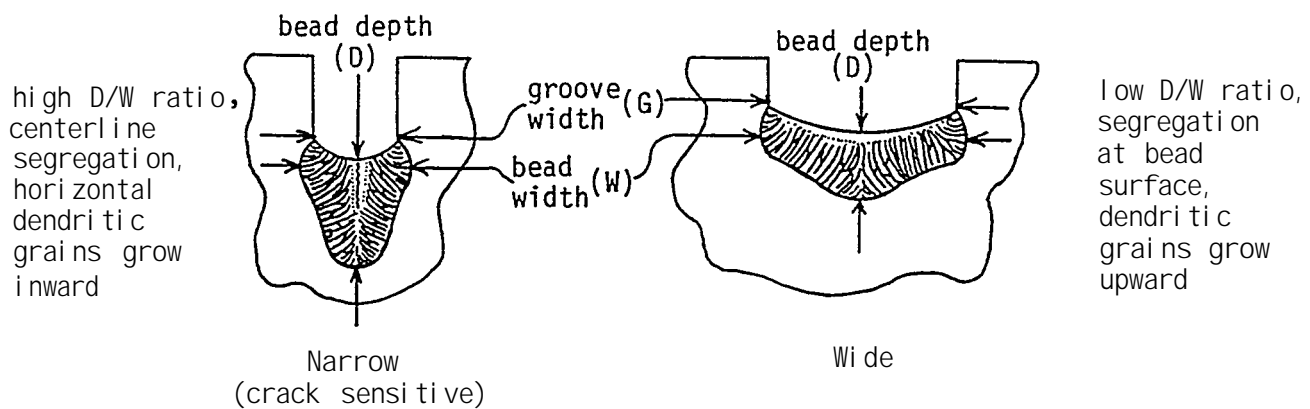

Figure 5. Depth/width ratio versus gap width

2.2.2. Depth-To-Width Ratio Versus Amperage. Testing has shown that the arc rotation mechanism described in Figure 1 works best at low current density for solid wire. If the amperage is raised too high, the two wires appear to produce a single steady arc and the weld cross section begins to take the shape of conventional GMAW. Figure 6 shows the penetrating spike

that occurs when the arc becomes columnated and stiff at higher amperage. This increases the D/W ratio and thus the weld becomes more crack sensitive. The bead cross sections outlined in Figure 6 are approximately to scale and were obtained with two twisted 1/16" dia. (2x1/16") solid electrodes and a gap width of 5/8". Although the maximum sidewall penetration W and the downward penetration D are increased with increasing amperage, the critical penetration W_1 changes very little. The D/W ratio is drastically reduced at lower amperage, reducing the chance of solidification cracking. The lower amperage limit is reached when the arc becomes unstable. An unstable arc causes spatter which collects in the shielding gas hardware and blocks shielding gas flow. Excessive spatter will also collect on the **groove walls and cause an undesirable bead surface** as shown in Figure 3b.

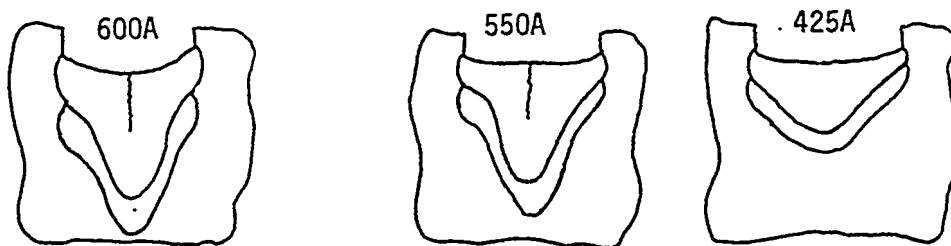

Figure 6. Depth/width ratio versus amperage

2.3. Effects of Travel Speed.

2.3.1. Solidification Cracking Versus Travel Speed. Although there is no apparent trend in D/W versus travel speed, faster travel speeds will increase the chance of solidification cracking. As shown in Charts V and VI changes in travel speed cause very little change in the D/W ratio although the **sidewall penetration (W_1-G) changes dramatically. The D/W ratio changes very little** because the change in sidewall penetration is compensated for by change in the depth of fill. This may not be true for a joint with a substantial bevel since an increase in fill will also increase the gap width.

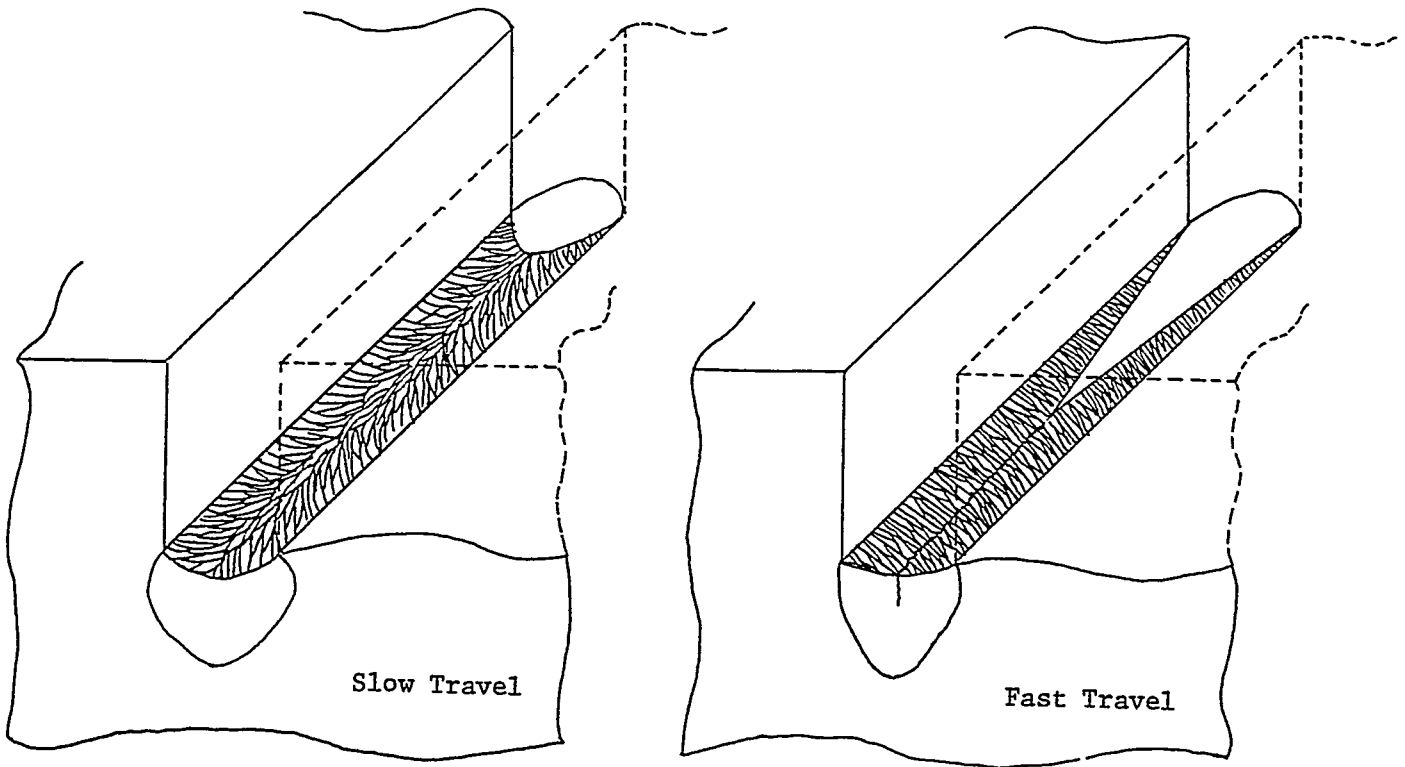

Figure 7. Solidification pattern of bead surface versus travel speed

The mechanism by which a fast travel speed causes solidification cracks is illustrated in Figure 7. Fast travel speed imparts a sharp chevron pattern to the weld puddle and weld ripples. The sharp chevron pattern of Figure 7b indicates the surface grains are growing inward toward each other thus increasing the chance of solidification cracking. A high D/W ratio is usually accompanied by a pattern as in Figure 7b. The D/W ratio is the dominant factor in causing solidification cracks, but with all other factors being equal the bead produced at a higher travel speed is more crack prone.

2.3.2. Lack of Fusion Versus Travel Speed. Charts V and VI show that when the gap is wide a fast travel speed will lead to lack of sidewall fusion at the bottom of the weld bead such as sketched in Figure 2a or 3b. Slow travel speeds have a dramatic advantage at wide gap widths because of the increased sidewall penetration in the critical location (W_1). When the gap

width is small a slow travel speed will cause lack of fusion between weld beads because:

- a) The downward penetration is decreased when the arc force is cushioned by a large weld puddle.
- b) The weld puddle becomes so large that the leading edge rolls ahead of the arc causing incomplete fusion or slag inclusions. An Examples of underbead slag are shown in Figure 8.



Figure 8. Slow travel speed that causes underbead slag inclusions, increased sidewall penetration, and undercut

2.3.3. Undercut Versus Travel Speed. Undercut due to slow travel speed has been observed with flux cored wires. The reason undercut occurs more readily with flux cored wires can be explained by comparing Chart V with Chart VI. The increase in sidewall penetration with slower travel speed is much more dramatic in Chart VI than the increase in Chart V. The dramatic increase of arc energy into the sidewalls goes hand in hand with undercut. The undercut and the dramatic increase in sidewall penetration with slow travel speed is shown in Figure 8.

3. Equipment.

3.1. Wire Twister And Wire Quality. A machine capable of twisting weld quality electrode is essential for evaluating the twist wire welding process. The development of a successful wire twister has allowed the twisting of various sizes and types of electrode with major gains in the area of the flux cored twist wire development, and knowledge of the potential problems with wire quality. Without proper knowledge of wire quality and adequate manufacturing steps quality welds are impossible. Photo 1 shows the first wire twisting machine developed at Puget Sound Naval Shipyard. From this machine we learned that the twist wire must have the following properties to obtain quality welds:

- a.) 25 - 30 degree twist angle.
- b.) wires must not untwist.
- c.) wires must not be serrated or gouged.
- d.) wires must not be more than 20% wrapped.
- e.) must not have residual torque after it is spooled.
- f.) must be properly level wound.

The second prototype wire twister shown in Photo 2 was developed with an emphasis on eliminating electrode helix. Normally, after the wire is twisted it is at residual yield point torsion. When the wire at yield point torsion is bent over the curved surfaces of the drive wheels or the wire take up spool it exceeds the yield point and is plastically deformed into a permanent helix.

The .045" diameter twist wire with helix will weave from side to side in the joint during welding causing lack of fusion when the wire wanders too far from the centerline of the joint.

The second wire twister eliminated helix by backspinning the take-up spool end of the wire so that it rotates in the grooves of the drive wheel. In this

way the torque is relieved at the same time the wire is bent over the surface of the drive wheels. When the torque is lowered below the yield point, the added bending force over the drive wheels will not result in excessive plastic flow and a helix. For backspinning to be effective, the drive wheel must be large enough to transmit torque over the curved surface and the wire must be free to turn axially.

The backspinning also eliminates the residual torque in the as-spooled wire. Residual torque in the spooled wire produces a strong tendency for the wire to spring off the spool and tangle. Too much backspinning will cause reverse helix and may cause the wire to untwist. The wire will also untwist when torque is relieved, if the material has a high elastic limit. If the wire untwists, a larger composite wire diameter is created which causes the wire to hang up in the contact tip resulting in an erratic arc or burn back.

The tension equalizer, shown in Photo 3, attached to the end of the spinning arbor is an important part of the wire twisting machine. This device equalizes the feed rate of the two wires as they are intertwisted.

The tension equalizer is made up of four wheels keyed together. When one wire is pulled from the arbor, torque is transferred to the other wheels. This forces the second wire to feed at the same rate, producing equal twisting.

Without the tension equalizer, a small differential change in the tension of the wires will cause them to twist unequally around each other. This unequal twisting or wrapping, even when difficult to detect visually, will cause the electrode to hang up in the contact tip due to the increase in the combined twist wire diameter.

Photo 8 shows a sample of wire with some areas where wrapping is readily visible and other areas where wrapping is not easily visible. Since wrapping

is a major problem the method shown in Figure 9. was devised to measure the degree of wrapping.

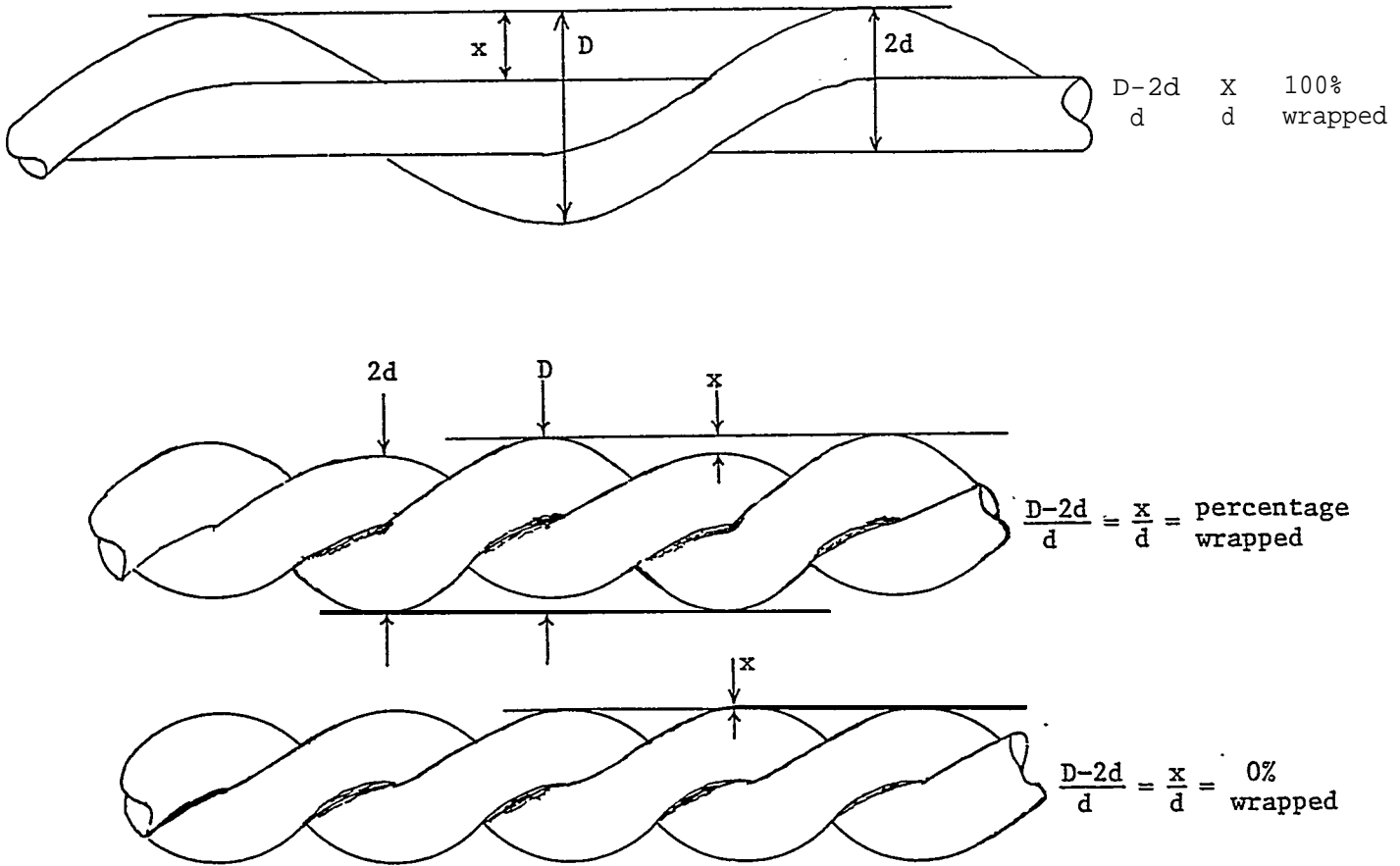

Figure 9. Method for measuring the degree of wrapping

3.2. Welding Equipment. The gas shielding device and the welding torch must be designed specifically for narrow gap twist wire welding. The remaining equipment is similar to conventional Gas Metal Arc Welding (GMAN) or Submerged Arc Welding (SAW) equipment. Currently, the only twist wire welding equipment available on the market is the TW-1 system made by Kobe Steel, the pioneer of twist wire welding. The TW-1 system is a well designed complete equipment package that was made specifically for twist wire welding. A complete list of system components is included in Appendix 1.

Two special features of the TW-1 are a remote control adjustment for centering the electrode and an excellent shielding gas system. The centering device is a small, remote, hand held pendant on a four foot cable with two buttons to move the electrode left or right to center the electrode in the gap. Currently, the travel speed can not be adjusted during welding because a small turn of the knob will set the travel speed beyond the acceptable range. It would be beneficial to have a fine travel speed adjustment knob which could be turned at least 90 degrees to vary the travel speed smoothly within an acceptable range of set travel speed limits. The TW-1 shielding system is made up of two separate, interchangeable devices for different base metal thicknesses. For joint depths 2" to 11", a shielding gas nozzle is attached to the torch so that the shielding gas ports are inside the groove. For weld passes 2" deep up to the cover pass, the shielding gas nozzle is replaced by a shielding gas box which forces and floods shielding gas into the joint from above the plate surface.

4. Usability.

4.1. Usability of Process.

4.1.1. Definition. One of the primary objectives of this study was to evaluate the useability of the twist wire process. Usability is defined as the ability to reliably produce high quality cost effective welds, over a wide range of gap widths and welding parameters, even when the joint contains gouges or other local defects.

Because of the configuration of narrow gap joints, repair of weld defects such as lack of fusion, undercut or porosity during welding is difficult due to the limited accessibility. Also, the repair may cause damage to the side wall of the joint which will in turn lead to more defects during subsequent welding. Because of this accessibility problem, repairs during welding may eliminate the cost advantage of this process if they happen too frequently.

The useability must also be based on the ability of the final weldment to pass nondestructive testing with a low reject rate. As with other narrow gap welding methods, the biggest hurdles are lack of sidewall fusion, reasonable production weld joint fit-up tolerances and weld parameter tolerances. Many previous narrow gap welding methods have failed to be usable because lack of sidewall fusion is obtained when:

- 1) tight weld joint fit-up tolerances can not be met in production,
- 2) the welding parameter range is too restrictive to be realistically maintained,
- 3) the parameters must be changed during welding to allow for fluctuations in joint fit-up and
- 4) seam tracking tolerance requirements are too restrictive and cannot be met.

4.1.2. Evaluation Method. To evaluate useability, test plates as shown in Figure 10 were run at different amperage voltage, travel speed, and stickout. The parameters were varied to determine allowable ranges for making sound welds (i.e., good sidewall fusion, no centerline cracking, no undercut, and very little spatter). A summary of defect types and causes is shown in Table I.

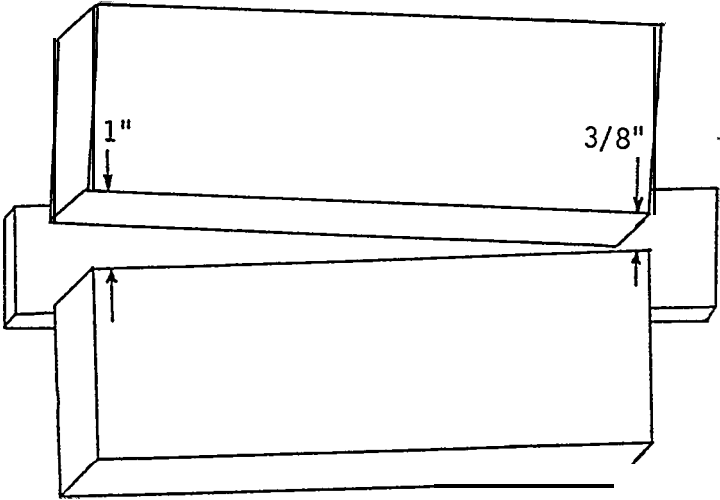

Figure 10. Schematic drawing of weld test plate

Defect Type	Causes				
	Gap Width	Travel Speed	Amperage	Voltage	Stickout
SOLIDIFICATION CRACKING (Depth/width >0.80)	too narrow (a)	too fast	too high (e)	too low (j)	
LACK OF SIDEWALL FUSION at bottom of bead	too wide (b)	too fast (c)	too low (g)	too low (k)	
LACK OF FUSION BETWEEN TWO WELD BEADS caused by an excessively large weld puddle rolling in front of the arc	too narrow	too Slow (d)	too high (f)		
UNDERCUT (causing lack of fusion on the next pass)	too narrow	too Slow		too high (i)	
EXCESSIVE SPATTER, unstable arc			too low (h)	too low	too short (l) too long (m)

Table 1. Summary of Defect Types and Causes

- (a) The depth-to-width ratio is labeled D/W on Charts I-VI. Freedom from solidification cracking was assured by $D/W < 0.8$. Charts I-VI show that D/W increases as the gap width G decreases, therefore $D/W = 0.8$ determines the minimum reliable gap width.
- (b) The "lack of sidewall fusion at bottom of bead" factor is labeled Freedom from, lack of sidewall fusion at bottom of bead was assured by $W-G > 2/64"$. Charts I-VI show that $W-G$ decreases as the gap width G increases, therefore $W-G = 2/64"$ determines the maximum reliable gap width.
- (c) The upper travel speed limit is best found by measuring the critical sidewall penetration minus the gap width (W_1-G) at the maximum gap to be welded. $W_1-G = 2/64"$ is the minimum allowable value.

- (d) The lower travel speed limit is best found by observing the weld puddle and weld stops at the smallest gap to be welded. If the leading edge of the puddle builds up ahead of the arc then the travel speed is too slow.
- (e) The upper amperage limit for the solid 2x2 mm electrode is found by using the $D/W = 0.8$ limit of Chart II. As shown in Chart II the upper amperage limit depends on the minimum gap width and vice versa.
- (f) The upper amperage limit for the 2x3/32" flux cored electrode is reached when the increase in travel speed (required to compensate for a larger weld puddle at high amperage) causes solidification cracking by the mechanism described in figure 7.
- (g) When $G > 3/4"$ for the 2x3/32" flux cored electrode the lower amperage limit is determined by the $W_1-G = 2/64"$ limit of Chart IV.
- (h) When $G < 3/4"$ for the 2x3/32" flux cored electrode, and in all gases for the 2x2 mm solid electrode the lower amperage limit is reached when the arc becomes unstable.
- (i) The upper voltage limit is reached when undercutting becomes deeper than $1/64"$ into the sidewalls.
- (j) At the smallest gap width welded, the lower voltage limit is reached when the D/W ratio becomes greater than 0.8. Low voltage dramatically reduces penetration into the sidewalls and thereby causes solidification cracking. For example, on Chart VI, 30V is too low at 700A and drives the D/W ratio above 0.8. To correct this situation the voltage should be raised to lower the D/W ratio.
- (k) At the widest gap width welded, the lower voltage limit is reached when W_1-G becomes less than $2/64"$.
- (l) The minimum urn stickout is the stickout used when the minimum amperage is determined. For example, the 2x2 mm solid wire has a minimum stable amperage of 500A at a stickout of $1\ 3/8"$. If 500A is used with an appreciably shorter stickout the arc becomes unstable **because the I²R wire preheating is lowered. Long stickouts are** important in the twist wire process for three reasons: 1) The deposition rate is increased for a given amperage. Since a long stickout will tend to lower the amperage the wire speed must be increased to maintain the given amperage level, 2) a long stickout keeps the contact tip away from the weld puddle to reduce spatter buildup and overheating problems, 3) a long stickout must be used to have a spray transfer at low current density. The solid wire works best with a spray transfer at low current density (see section 2.2.2).

- (m) when the amperage is set near the minimum required for a stable arc and the stickout is increased, the amperage will drop below the level required for a stable arc. The best way to avoid this is to set the desired parameters with the desired stickout. When a low spot in the joint is welded the stickout will increase, the voltage will slightly increase, and the amperage will noticeably decrease. Thus, when the operator sees a drop in amperage on the meter, the stickout should be shortened. Similarly, when the operator sees the amperage rise, the stickout should be increased.

4.1.3. Wire Size and Type. The results of useability tests with various electrode sizes (2x.045", 2x1/16", 2x2 mm, 2x3/32 ") and electrode types (solid, and flux cored) are shown in Charts I through IV. Macro-etched bead cross sections using the various electrodes and parameters in Charts I thru IV are shown in Photos 4 thru 7. D/W vs G (probability of solidification **cracking versus gap width**) and W_1-G vs. G (sidewall penetration in the critical location versus gap width) were chosen for comparison on each Chart I-IV because these factors will indicate the fit-up tolerances. The chances of centerline cracking at narrow groove widths and probability of lack of fusion at wide groove widths define the total acceptable gap width range. For the sake of comparison a travel speed of 10 ipm was used in Charts I-IV. A travel speed of 10 ipm was within the optimum range for all electrodes tested. The voltages varied to correspond to the amperage ranges tested. The stickouts varied according to the optimum arc characteristics for each wire tested.

4.1.3.1. Conclusion on Wire Size and Type. Conclusions on acceptable wire size and amperage ranges can be made from Charts I-IV based on a plus or minus 1/8" fit-up tolerance requirement. As a practical matter, the ideal joint width range is 1/2"-3/4". Below 1/2" joint accessibility and visibility become more of a problem. Defects which occur in a groove less than 1/2" wide are more difficult to remove than defects in grooves with wider

gaps. The conclusions from Chart **I-IV** for the wire sizes tested are as follows:

a) 2x1/16" solid twist wire is unacceptable. The D/W ratio versus G curves of Chart **I** are too high and intersect the $D/W = 0.8$ limit at a high gap width value. **The sidewall penetration in the critical location W_1-G versus gap width G curves of Chart I are low, thus intersecting the $W_1-G = 1/32$ "** limit at a low value of G. Thus, the minimum gap width is too wide, the maximum gap width is too narrow, and the gap width range is not broad enough to allow for the required fit-up tolerances necessary in the shipbuilding industry. The usable gap width range is marginally acceptable at 425A; however, the current density is too low at 425A for reliable arc stability.

b) 2x2 mm solid twist wire provides a sufficiently broad gap width range between 500A and 550A. The D/W ratio is lowest at 500A, thus the gap width can be narrower and still avoid solidification cracking. Below 500A the arc becomes unstable. Above 550A the D/W ratio is too high to reliably produce a crack-free weld pass over a sufficiently wide gap width range.

c) 2x1/16" flux cored twist wire is unacceptable. The usable gap width is broad enough at 450A, however the range falls below the 1/2" minimum gap width necessary for joint accessibility. The D/W ratio versus gap width curve is acceptable over a broad amperage range of 350A to 550A. The low D/W ratios are typical of flux cored twist wire with arc stabilizers producing continuous arc rotation.

d) 2x3/32" flux cored twist wire has an extremely wide range of usable gap widths, very high sidewall penetration curves, extremely low D/W ratio curves and a broad amperage range.

Table II below shows the values for D/W and W_1-G at 1/8" intervals within the desirable gap width range of 1/2" - 3/4".

	Amperage	G range		D/W (0.8 max)			W_1-G (.03" min)		
		min.	max.	G= 1/2"	G= 5/8"	G= 3/4"	G= 1/2"	G= 5/8"	G= 3/4"
2x2 mm solid	500	.47	.83	.78	.63	.53	.07	.05	.04
	550	.56	.83	.88*	.75	.60	.07	.05	.04
	650	.68	.83	.97*	.85*	.74	.10	.08	.06
2x3/32" flux cored	550	.37	.86	.60	.48	.38	.14	.07	.03
	650	.37	1.0	.62	.56	.50	.19	.15	.13

* D/W is unacceptable (see footnote a of Table 1).

Table II. Comparison of Two Usable Twist Wire Electrodes

4.1.4. Parameter Ranges. Tables III and IV show the parameter ranges for various fit-up tolerances with the 2x2 mm solid and 2x3/32" flux cored electrodes. The obvious trend of Tables III and IV is that the tighter the fit-up tolerance the broader the parameter range will be.

The 2x2 mm solid electrode has a wide parameter range when the fit-up is between 5/8" and 3/4". When the gap range falls below 5/8" (1/2" - 5/8" and 1/2" - 3/4") lower amperage should be used to avoid solidification cracks; and the travel speed should be 10ipm minimum to avoid an excessively large weld puddle which rolls ahead of the arc.

With the 2x3/32" flux cored electrode a fit-up tolerance of 3/8" is possible, however, the parameter range becomes very restrictive. At 1/8" and 1/4" fit-up tolerance the parameter ranges are extremely wide.

Fitup	Pass	Gap Width	Amperage	Volt	Travel Speed (ipm)	Stick out (inches)
Fitup Within 1/8"	Root and fill	1/2" - 5/8"	500-525	30-32	10-12	1 3/8
		5/8" - 3/4"	500-525	30-32	9-11	1 3/8
			526-550	30-32	9-11	1 3/8
			551-575	30-32	9.5-11.5	1 3/8
Fitup Within 1/4"	Root and fill	1/2" - 3/4"	500-525	30-32	10-11	1 3/8
Cover Passes or 2 Pass per Layer Fill Passes		3/4" Wide or greater	500-525	30-33	10-14	1 3/8
			526-550	30-33	10-14	1 3/8
			551-600	30-33	10-14	1 3/8
			601-625	30-33	10-14	1 3/8

Table III. 2x5/64" Solid Wire Electrode, Fit-up and Welding Parameters

Fitup)	Pass	Gap Width	Amperage	Vol t	Travel Speed (i pm)	Stick-Out (i nches)
Fitup Within 1/8 "	Root	1/2" -3/4"	550-575	26-29	9-10	1 1/2
	One pass per layer fill pass	1/2" -5/8"	550-575	26-29	10-10.5	<u>1 1/2</u>
			576-600	26-29	10-10.5	<u>1 1/2</u>
		5/8" -3/4"	<u>550-575</u>	<u>26-29</u>	<u>9.5-10.5</u>	<u>1 1/2</u>
			<u>576-600</u>	<u>26-29</u>	<u>9.5-10.5</u>	<u>1 1/2</u>
			<u>601-625</u>	<u>26-30</u>	<u>10-11</u>	<u>1 1/2</u>
			<u>626-650</u>	<u>27-31</u>	<u>10-11.5</u>	<u>1 1/2</u>
		3/4" -7/8"	576-600	27-30	9.5-10	1 1/2
			601-625	27-31	10-10.5	1 1/2
	626-650		28-32	10-11	1 1/2	
	651-675		29-33	10-11	1 1/2	
	Fitup Within 1/4"	Root	1/2" -3/4"	550-575	26-29	9-10
One pass per layer fill pass		1/2" -3/4"	550-575	26-29	10-10.5	<u>1 1/2</u>
			576-600	26-29	10-10.5	<u>1 1/2</u>
		5/8" -7/8"	<u>576-600</u>	<u>27-29</u>	<u>9.5-10</u>	<u>1 1/2</u>
			<u>601-625</u>	<u>27-30</u>	<u>10-10.5</u>	<u>1 1/2</u>
<u>626-650</u>	<u>28-31</u>		<u>10-11.5</u>	<u>1 1/2</u>		
Fitup Within 3/8"	All	1/2" -7/8"	580-620	28-29	10-10.5	1 1/2
Cover Passes or 2 Pass per Layer Fill Passes	7/8" Wide or greater	<u>600-625</u>	<u>28-31</u>	<u>13-20</u>	<u>1 1/2</u>	
		<u>626-650</u>	<u>28-32</u>	<u>13-20</u>	<u>1 1/2</u>	
		<u>651-675</u>	<u>29-33</u>	<u>14-20</u>	<u>1 1/2</u>	
		<u>676-700</u>	<u>30-34</u>	<u>14-20</u>	<u>1 1/2</u>	

Table IV. 2x3/32" Flux Cored Electroded Fit-up and
Welding Parameters

4.1.5. Electrode Centering Tolerance. To determine the maximum distance the electrode can be offset from the groove centerline, three test plates such as in Figure 10 were welded with 1/16", 3/32" and 1/8" electrode offset using the 2x2mm electrode. Cross sections were cut at 1/8" increments in gap widths along the plate. Measurements were taken from the cross sections as shown in Figure 11.

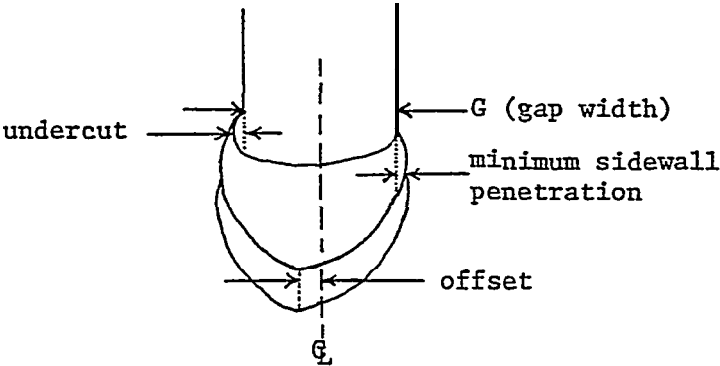

Figure 11. Measurements for electrode offset

These tests show that the maximum allowable electrode offset is 1/16". When the offset is greater than 1/16", lack of fusion or slag inclusion may occur for gap widths of 3/4" or greater; and undercut deeper than 1/64" will be likely when $G < 1/2$ ".

4.1.6. Welding over Sidewall Defects. Test plates with sidewall gouges of varying depth and radius were welded to determine the maximum depth and minimum radius that can be tolerated. These tests indicate that quality welds can be obtained in joints with sidewall defects providing:

- (a) The defects are faired into 1/2" minimum radius.
- (b) The local gap width at the deepest point of the defect does not exceed the allowable range of Table III and Table IV.

4.1.7. Joint Design. Figure 12 shows the various joint designs that can be used with the twist wire process. The joints shown in Figure 12c, d and e are **the most efficient with regard to joint preparation and fit-up since** they only require two flame cuts and have a positive reference to fit against during assembly.

Photo 9 shows two joints of the type shown in Figure 12e. Photo 9a was welded using the 2x3/32" flux cored electrode. Photo 9b was welded using the 2x2mm electrode. Photos 10 and 11 show welds of the joint design type shown in Figure 12c. Joint design type 12c has better accessibility to reduce the chances of the torch and contact tip arcing out on the sidewall, and allows easier repair of visual defects during welding. Photo 10 shows the centerline cracking that can be expected on the first and second pass when solid 2x2mm electrode is used. The crack depths are .190" and .185" for the first and second pass respectively. The depth of penetration of the second pass into the first pass is .350". Photo 11, 12, and 13 show the crack-free welds resulting from the low D/M ratio of flux cored wires.

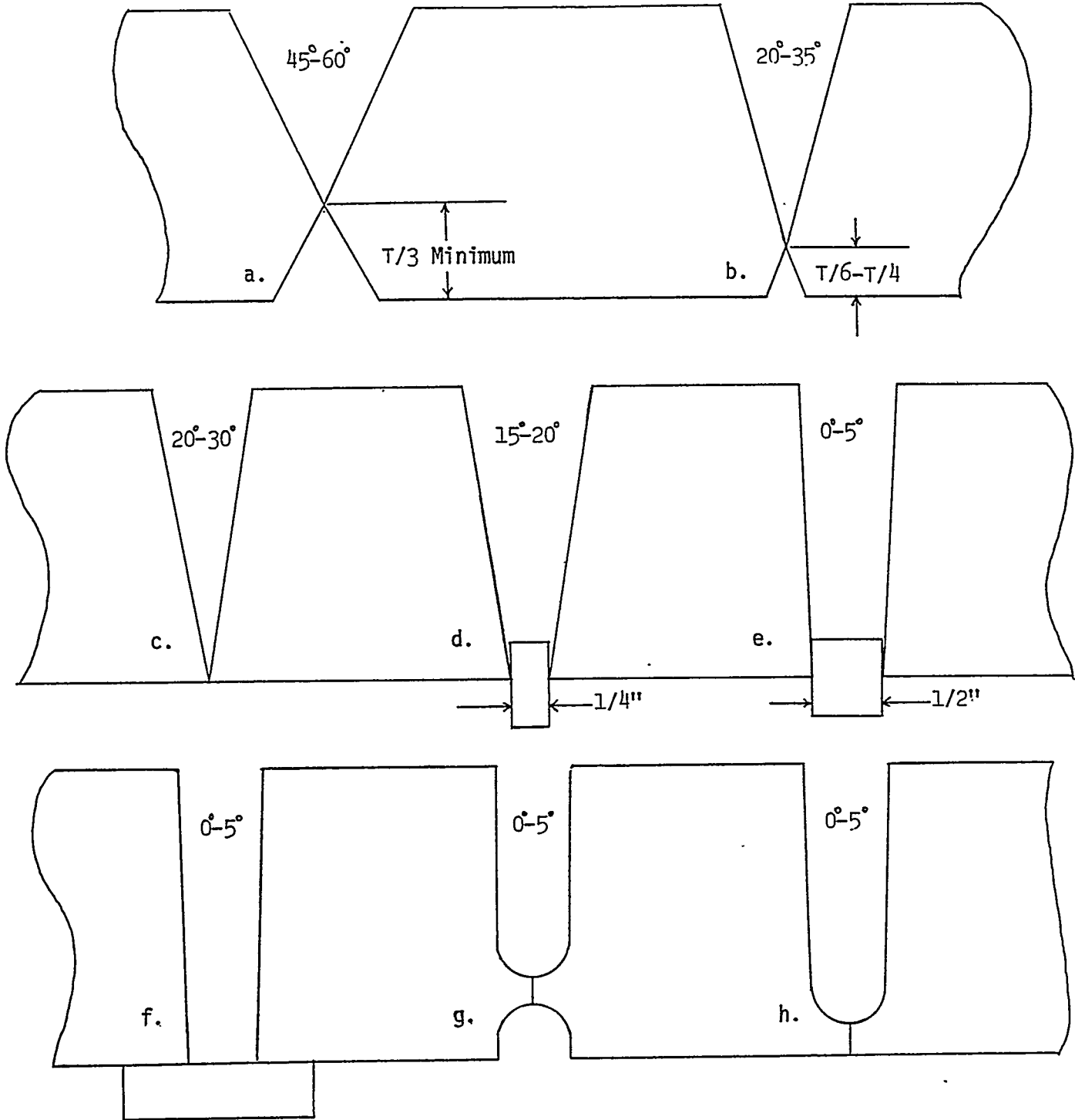

Figure 12. Joint design

4.2. Usability of Welding Equipment.

4.2.1. Welding of 20' Plate. One of the main objectives of this study was to test the durability of the twist wire welding process and equipment by using a full scale production mock-up. To accomplish this a 20' x 5' x 2 1/2" carbon steel plate was prepared and welded during a demonstration to the SP-7 panel on January 28, 1986.

The joint design was a 2 degree included angle with a 5/8" backing bar inserted into the joint. Only two problems were encountered during welding both of which were not related to the weld process: 1) the wire feed motor rolls were loose on the root pass causing 7 intervals of lack of sidewall wetting 1/4" - 5/8" long where the feed rolls slipped on the wire. 2) On the third pass the power cables caught on a fairing device (dog) stopping the weld carriage and causing gross undercut and cold lap. Since the demonstration was in progress time was not taken to remove these defects. Except for the above defects the weld had excellent visual appearance. No lack of sidewall wetting, undercut, solidification cracking or porosity was found. The slag was removed by tapping with a slag hammer once every 2" and blowing out the joint with compressed air. The joint was filled in 12 passes including the single 1 1/2" wide cover pass. The backgouge was made in 3 passes with an automatic carbon arc machine. No porosity was seen during backgouge.

The backgouge side was welded with one pass per layer up to 7/8" gap width followed by two passes per layer up to flush and then a 3 pass cover. The travel speed was increased to 16 inches per minute for the two pass per layer beads to give a smooth bead tie in.

The equipment held up extremely well during welding. The shielding gas system design eliminated porosity and problems with weld spatter buildup. The cooling system withstood the heat of cover pass welding (when the gas shielding system is closest to the weld puddle and most likely to overheat).

The first time the 20 foot plate was welded there was a problem with overheating of the contact tip. Photo 14a shows an overheated contact tip used for 2 passes in the 20 foot plate. The overheating was caused by insufficient heat transfer to the torch. Since the Kobe torch was made for a smaller wire size (2x2mm) very little wall thickness is left when the threaded end is bored out for the 2x3/32 flux cored wire. A thicker torch as shown in Photo 15 was made which could be tapped with a larger thread size (3/8"). With a larger thread the contact tip in Photo 14b did not have the problems of accelerated wear, melting, and spatter buildup.

The torch pictured in Photo 15 consists of a copper contact bar brazed between two pieces of Monel for extra stiffness, and two internal cooling loops; one on each side of the wire bore. The durability of the cooling system and the heat transfer across the threads to the contact tip was proved by the fact that the contact tip in Photo 14b was used to fill the entire 20' plate.

The 20 foot plate was radiographically inspected and found to have 2 slag inclusions totaling 1", 1 area of lack of fusion totalling 1 3/4" and one transverse crack 5/8" long. The crack was discovered during backgouge at the exact location where the two backing bars butt together. The crack location was marked prior to radiography. It is probable that the crack was due to hydrogen embrittlement since: a) no preheat was used, c) the crack was transverse and occurred at a pre-notched location, d) it propagated only in the high strength weld metal, and e) it was allowed 4 days to develop before backgouge.

The total length of rejectable weld in 240 inches was 3 3/8" or 1.4%.

4.2.2. Kobe System. The Kobe system was also **demonstrated to the SP-7** panel on January 28th. A 5'x5'x2" plate was **welded using a 2° level** and a 5/8" backing **insert. The solid 2x2mm twist wire** also worked very well with no visible defects. The plate was filled in 9 passes including a single cover pass. The equipment held up well and is production ready.

The Kobe System has the advantage that the direction of welding can be reversed in the runoff tabs without stopping the machine since slag only needs to be removed every third pass. When the travel speed is reversed without stopping, the stickout is adjusted by raising the torch approximately 1/4" until the amperage meter again reads the proper value. Contact tip life was excellent and the equipment proved to be durable and production ready.

4.2.3. Vision System. The Kobe fiber-optic vision system arrived on Jan. 28 so it was not used during the demonstration but was used during completion of the 20 foot plate. The system consists of a viewing lens of excellent quality with a 6' fiber-optic cable leading to a 2 1/2" diameter gun-sight type viewing screen with graduated cross-hairs. The lens can focus from 6" up to 24" from the arc so that it can be kept away from smoke and spatter. The image shows wire, arc, weld puddle and side walls as clearly as a welder could see with a hood. This vision system gives the operator freedom of movement and takes the fatigue out of the process.

Since the twist wire electrode must be centered $\pm 1/16"$ in a narrow groove it is very important to have a guidance system to avoid operator fatigue. The twenty foot test plate was welded most the way with the operator on hands and knees and using a welding hood, proving that it can be done without a vision system. However, when the Kobe fiber-optic system was used for the final passes it had instant operator approval.

5. Conclusions.

The twist wire welding process provides an excellent alternative to expensive and time consuming conventional welding processes. The twist wire **welding** process gives good sidewall fusion in narrow gap weld joints by the inherent weaving or rotating arc. Also, the necessary equipment for twist wire welding is not complicated.

The basic requirements that must be complied with for successful narrow gap welding include the following:

- 1) Quality control of wire twisting is very important.
Details such as twist angle, wrapping, helix, residual torsion stress, serrations and tightness of twists must be monitored.
- 2) Weld joints that are too narrow will lead to solidification cracking and weld joints that are too wide will cause lack of fusion.

Both large diameter solid wire (2mm) and large diameter flux cored wire (3/32") will produce high quality welds in thick material. Other wire sizes and types failed the useability test of section 4.1.3. Both the 2x2mm solid and the 2x3/32" flux cored wires exceeded the strict useability requirements of section 4. including:

- a) a wide range of welding parameters
- b) a wide joint fit-up tolerance
- c) a wide electrode centering tolerance
- d) an acceptable contact tip life
- e) ability to weld over sidewall defects
- f) low reject rate

The end-of-project demonstration on January 28, 1986 proved the useability of both the KOBE TW-1 system using the 2x2mm solid electrode and the 2x3/32" flux cored electrode using PSNS equipment. The reject rate using the 2x3/32" electrode was 1.4% in 240" of weld.

A tracking system is required to avoid operator fatigue when maintaining the $\pm 1/16$ " electrode centering tolerance. The fiber-optic vision system used gives the operator freedom of movement and eliminates fatigue.

LIST OF REFERENCES

- 1) Kimura, S., Ichihara, I., and Nagai, Y., "Narrow-Gap, Gas Metal Arc Welding Process in Flat Position", *Welding Journal*, July 1979, pages 44-52.
- 2) Yasuhiro Nagai, Chigasaki; Toshisada Kashimura, Kamakura; Kuni o Kaita, Kamakura; Tetsuro Kawaberi, Kamakura, all of Japan; assignors to Kabushiki Kaisha Kobe Seiko Sho, Kobe, Japan; "Arc Welding Process Using a Consumable Stranded Wire Electrode", United States Patent Publication No. 4,386,259, filed March 31, 1981.

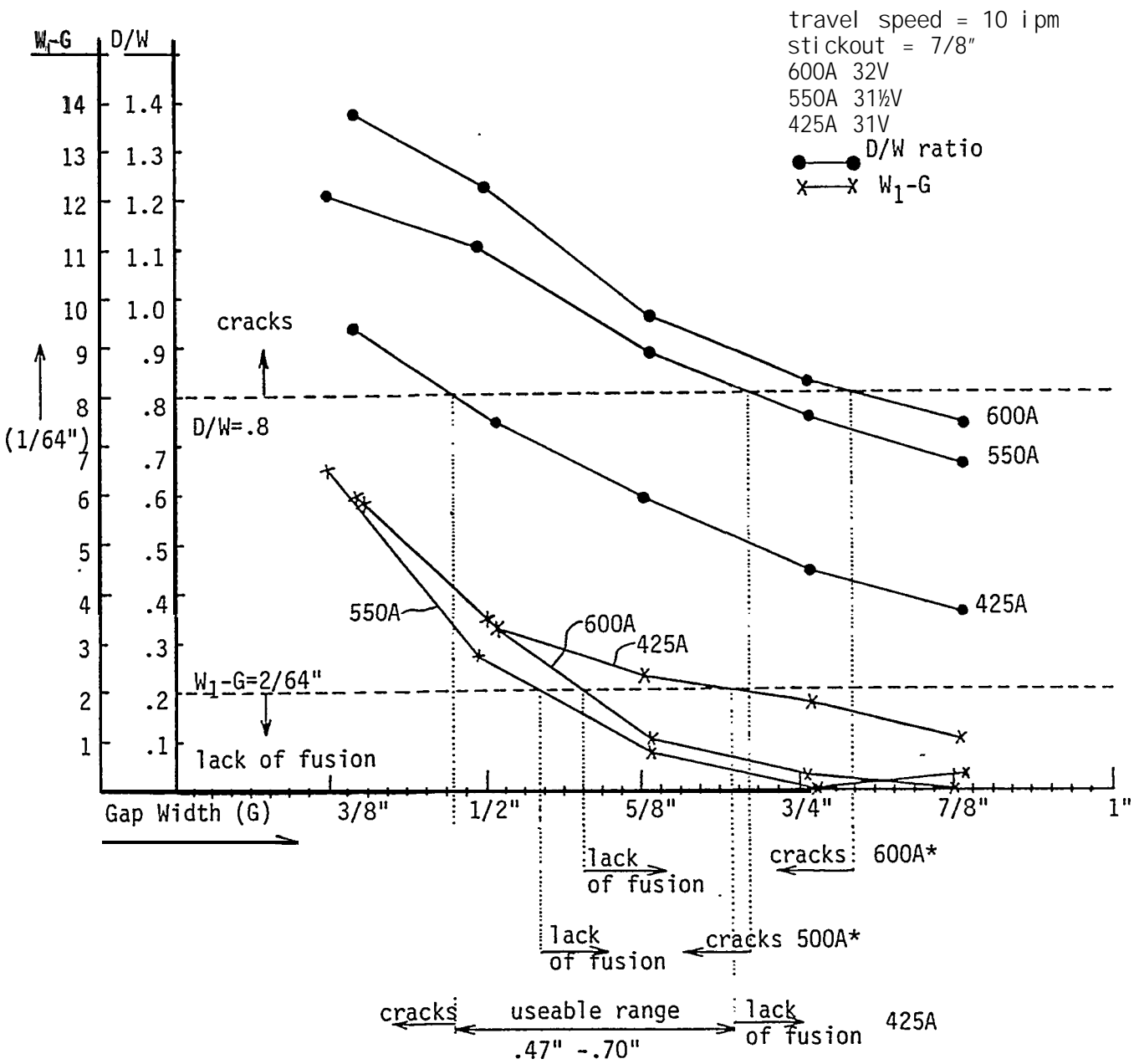

* No useable range at high amperage because of a high risk of cracks or lack of fusion at any value of G.

See footnotes a&b of Table 1.

Chart I. Usable Range of Amperage and Gap Width for 2x1/16" solid Electrode

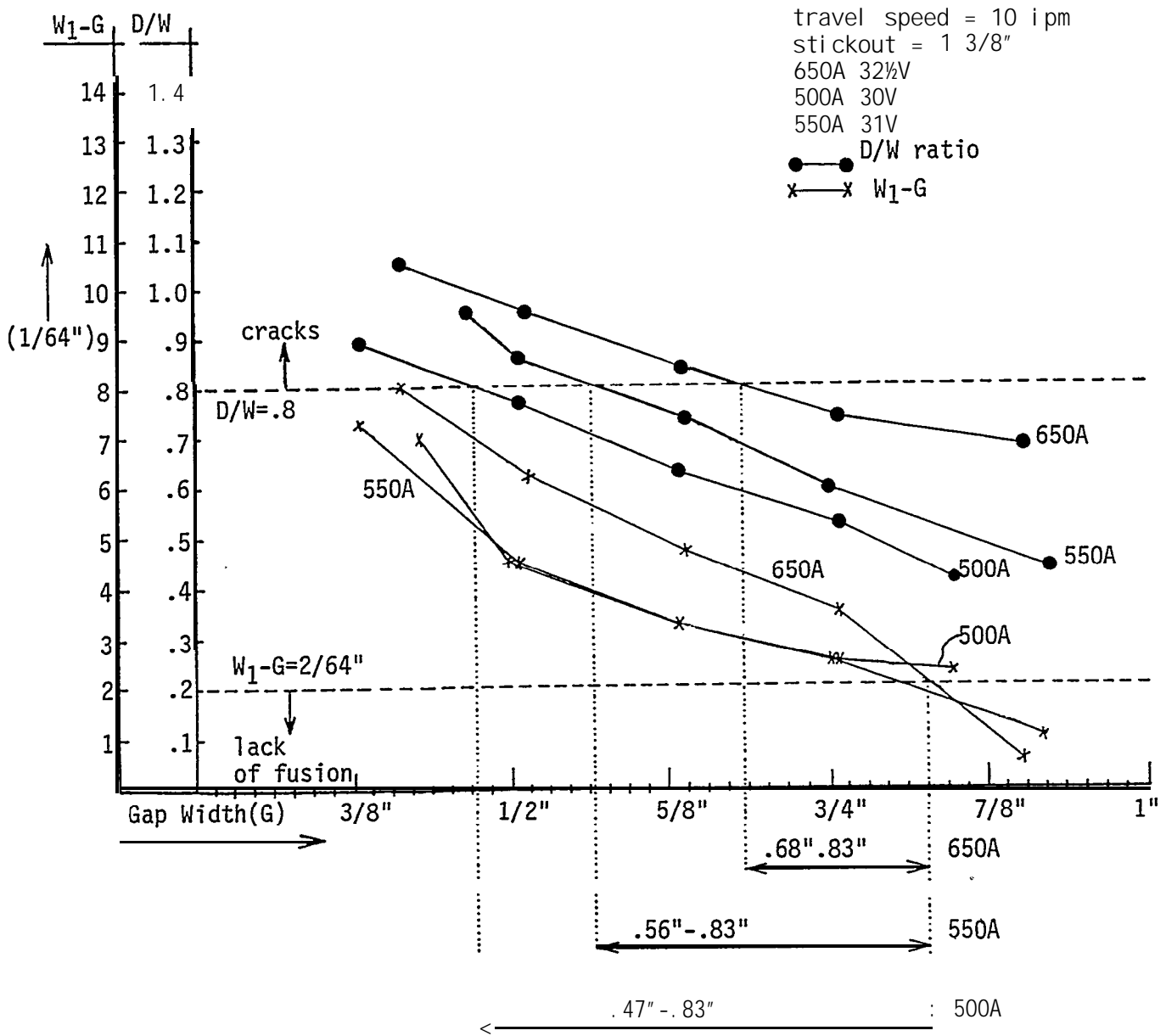

See footnotes a&b of Table 1.

Chart II. Usable Range of Amperage and Gap Width for 2x2mm Solid Electrode

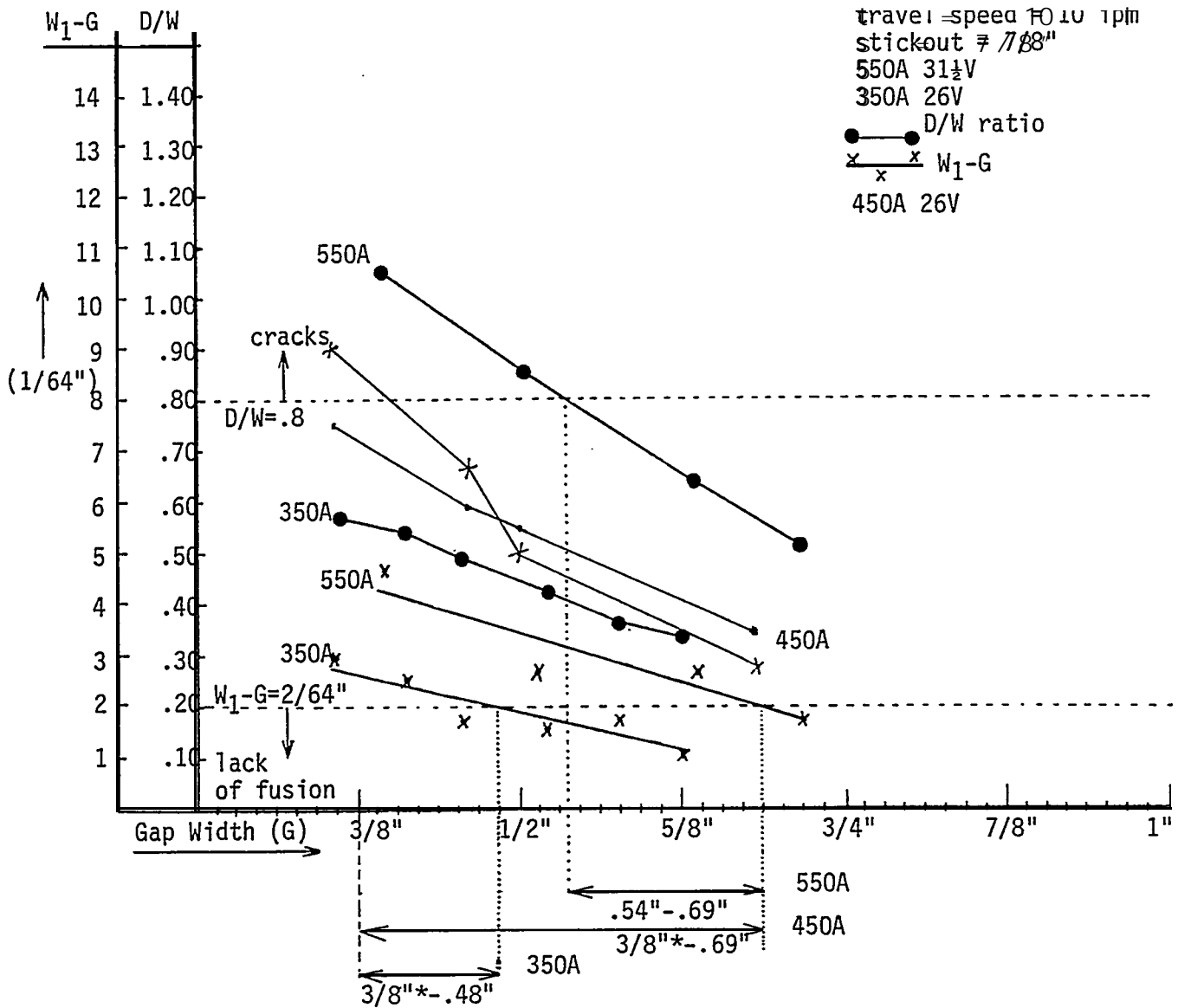

See footnotes a&b of Table 1.

* The D/W ratio is so low with **flux cored** wires that the D/W ratio curves only intersect the D/W = 0.8 limit at high amperage. At low Amperage the lower gap width limit is set at 3/8". Below 3/8" the gap width is too narrow to accommodate the contact tip.

Chart III. Usable Range of Amperage and Gap Width for 2x1/16"
Flux Cored Electrode

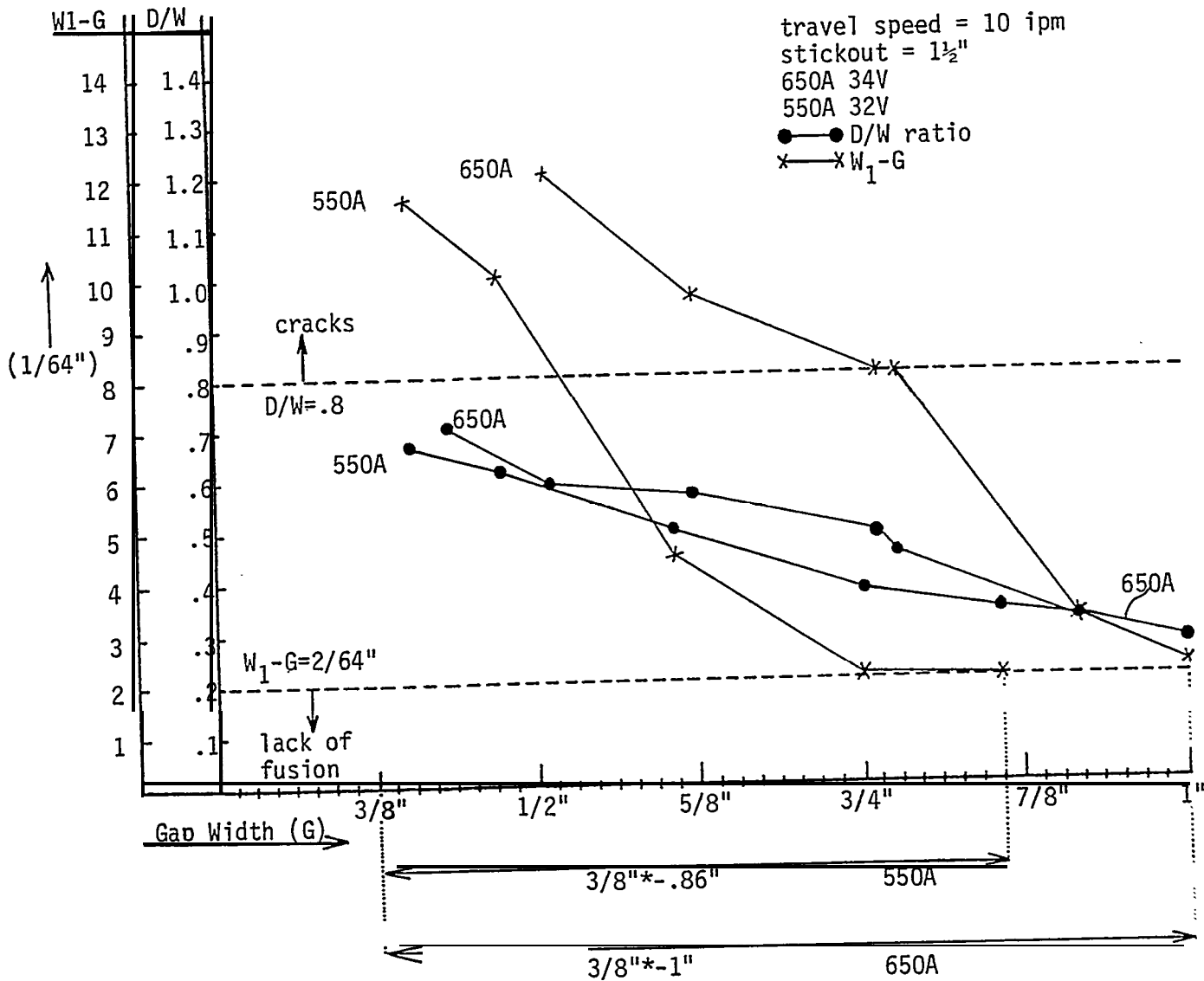

See footnote b of Table 1 for explanation of upper gap width limit.

* The D/W ratio is so low with flux cored wires that the D/W ratio curves do not intersect the D/W = .8 limit. The lower gap width limit is set at 3/8". Below 3/8" the gap width is too narrow to accommodate the contact tip.

Chart IV. Usable Range of Amperage and Gap Width for 2x3/32" Flux Cord Electrode

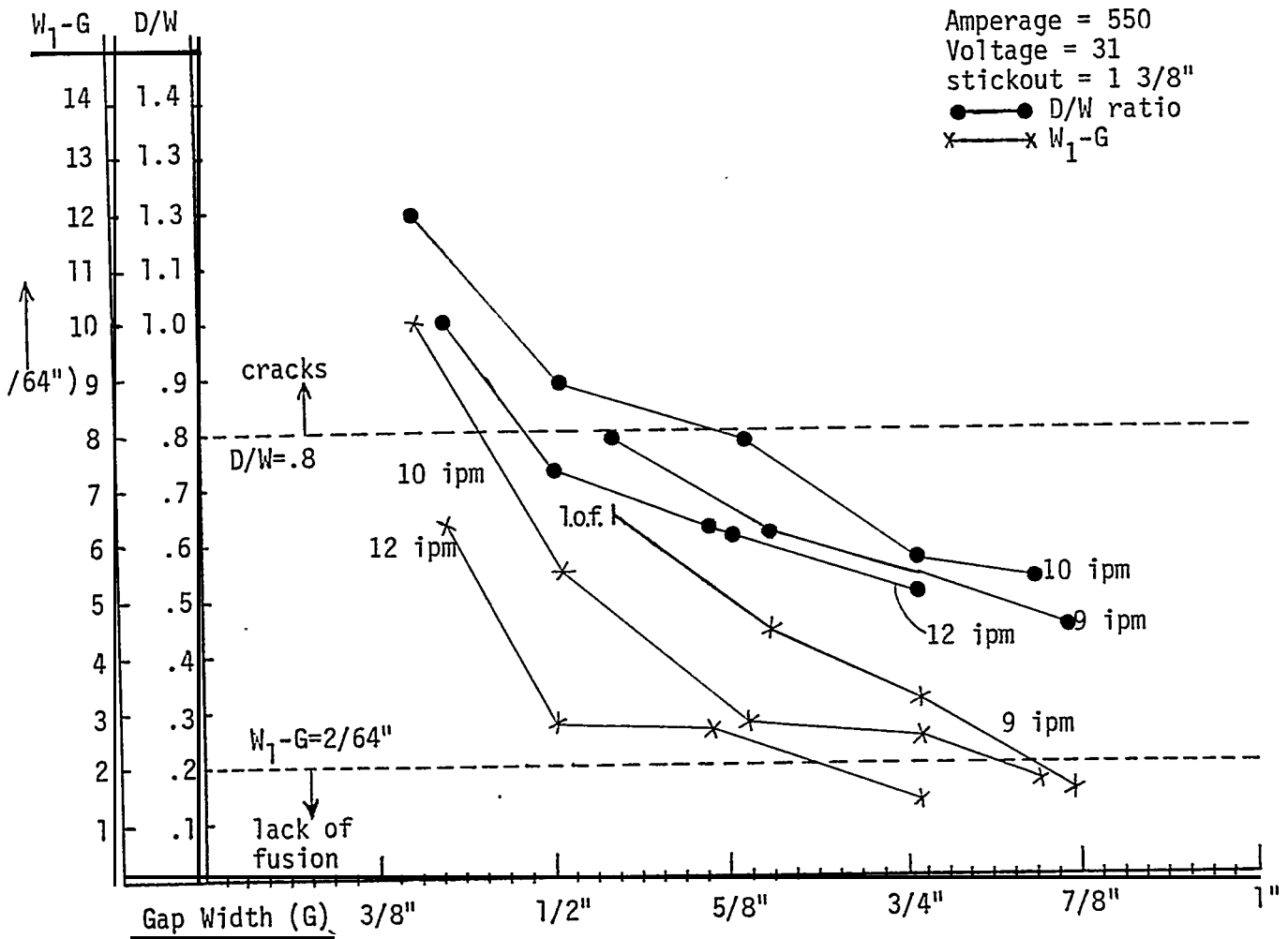

Chart V. Effects of Travel Speed for 2x2 mm Solid Electrode

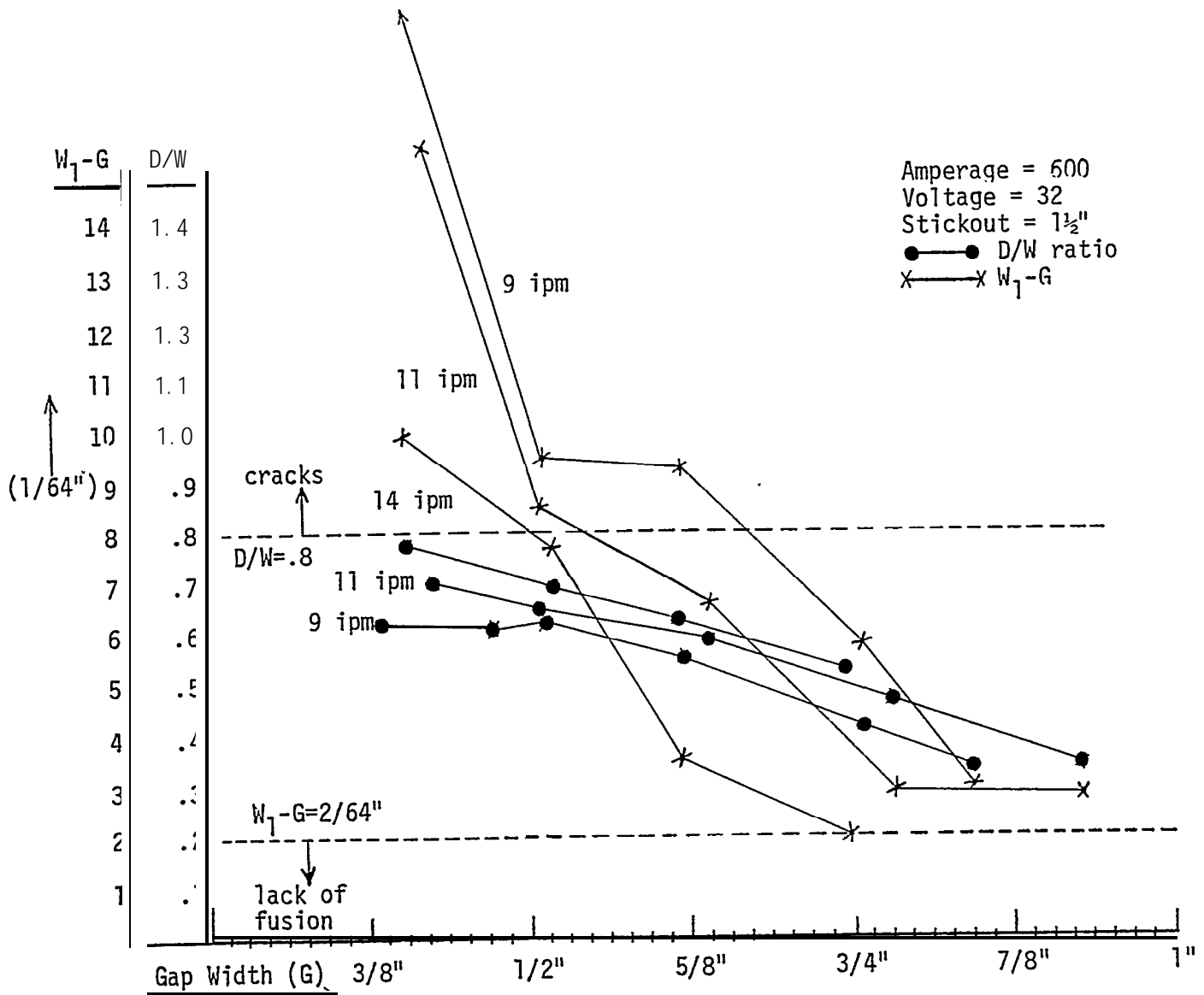

Chart VI. Effects of Travel Speed for 2x3/32" Flux Cored Electrode

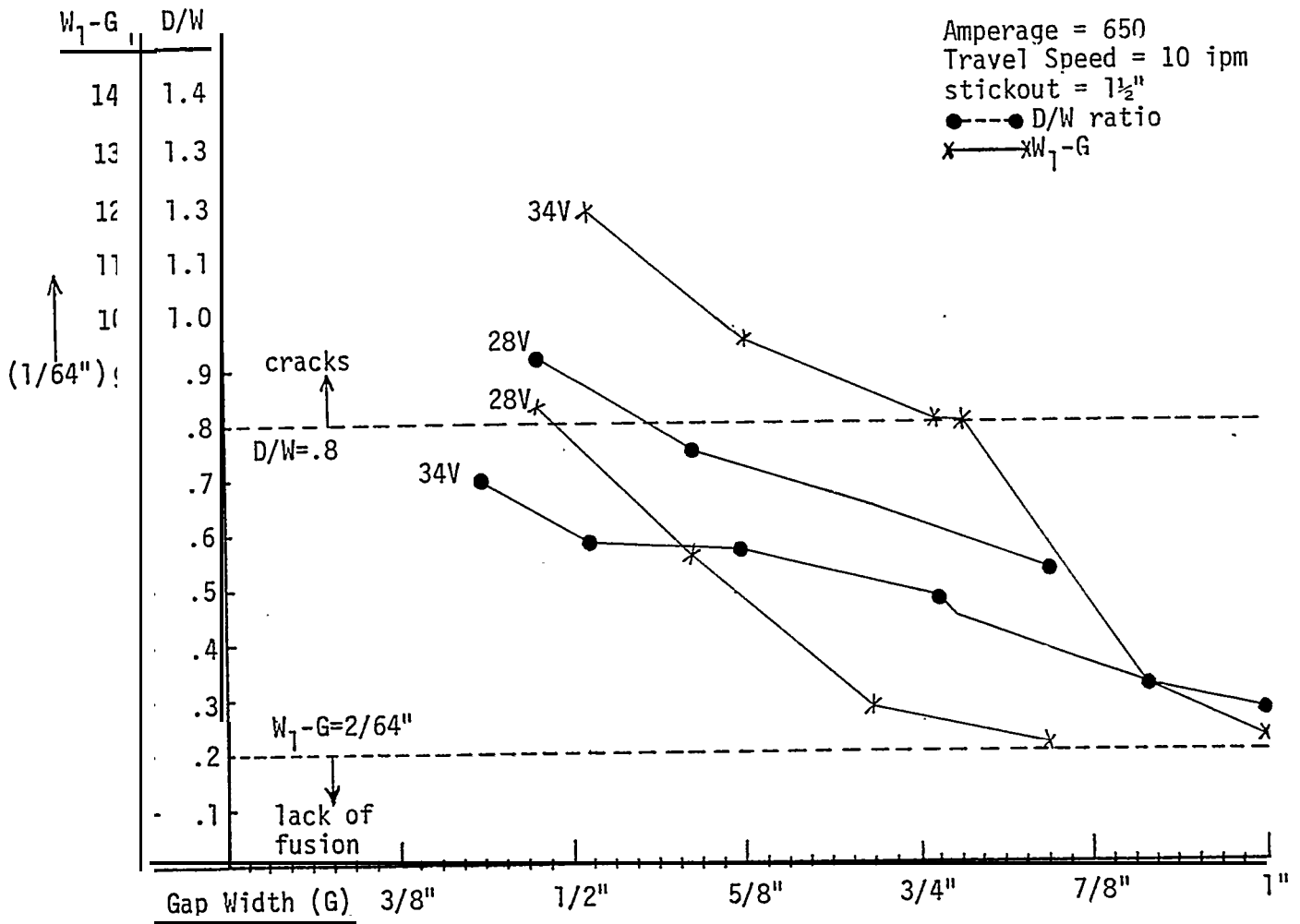
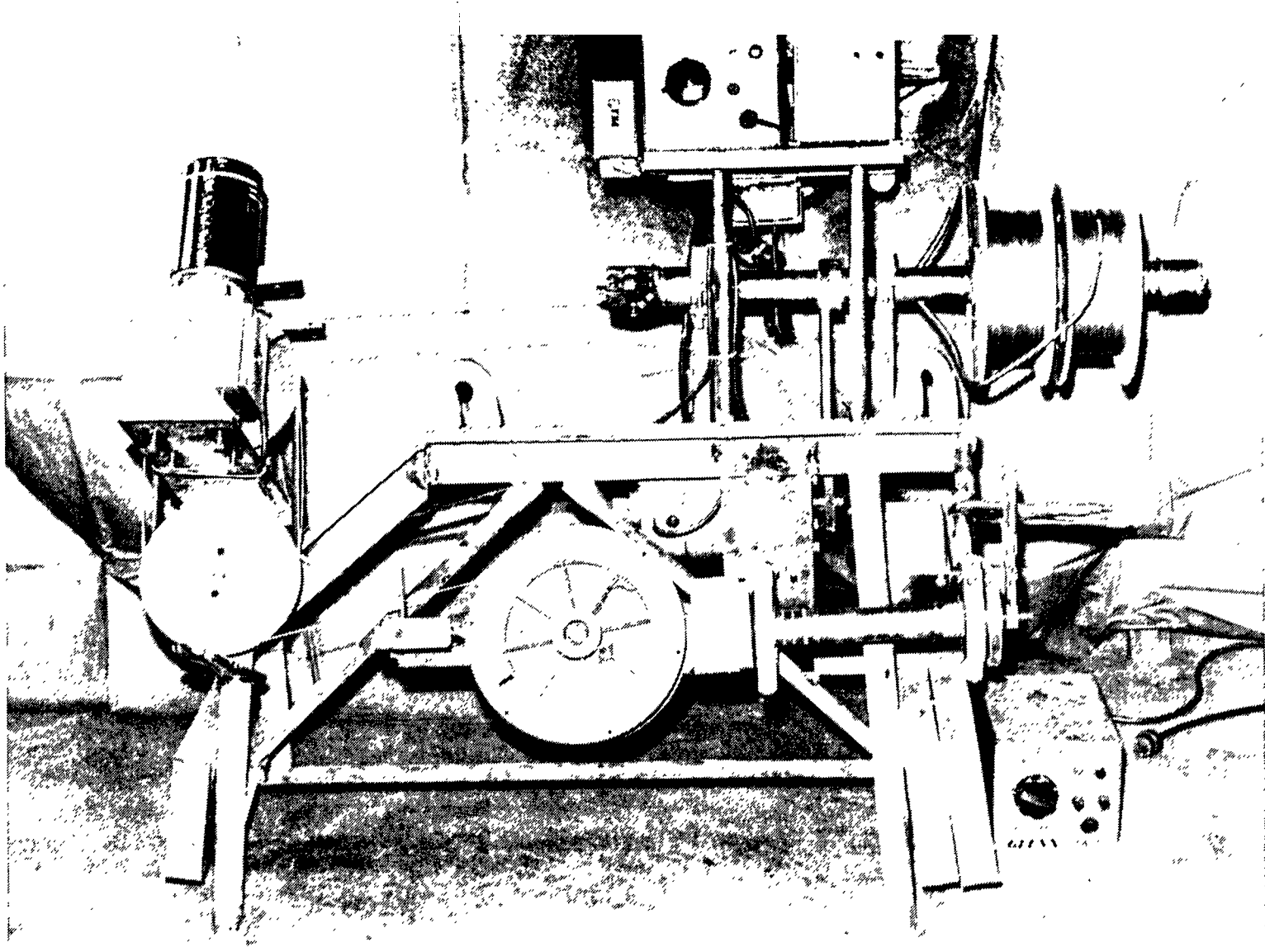
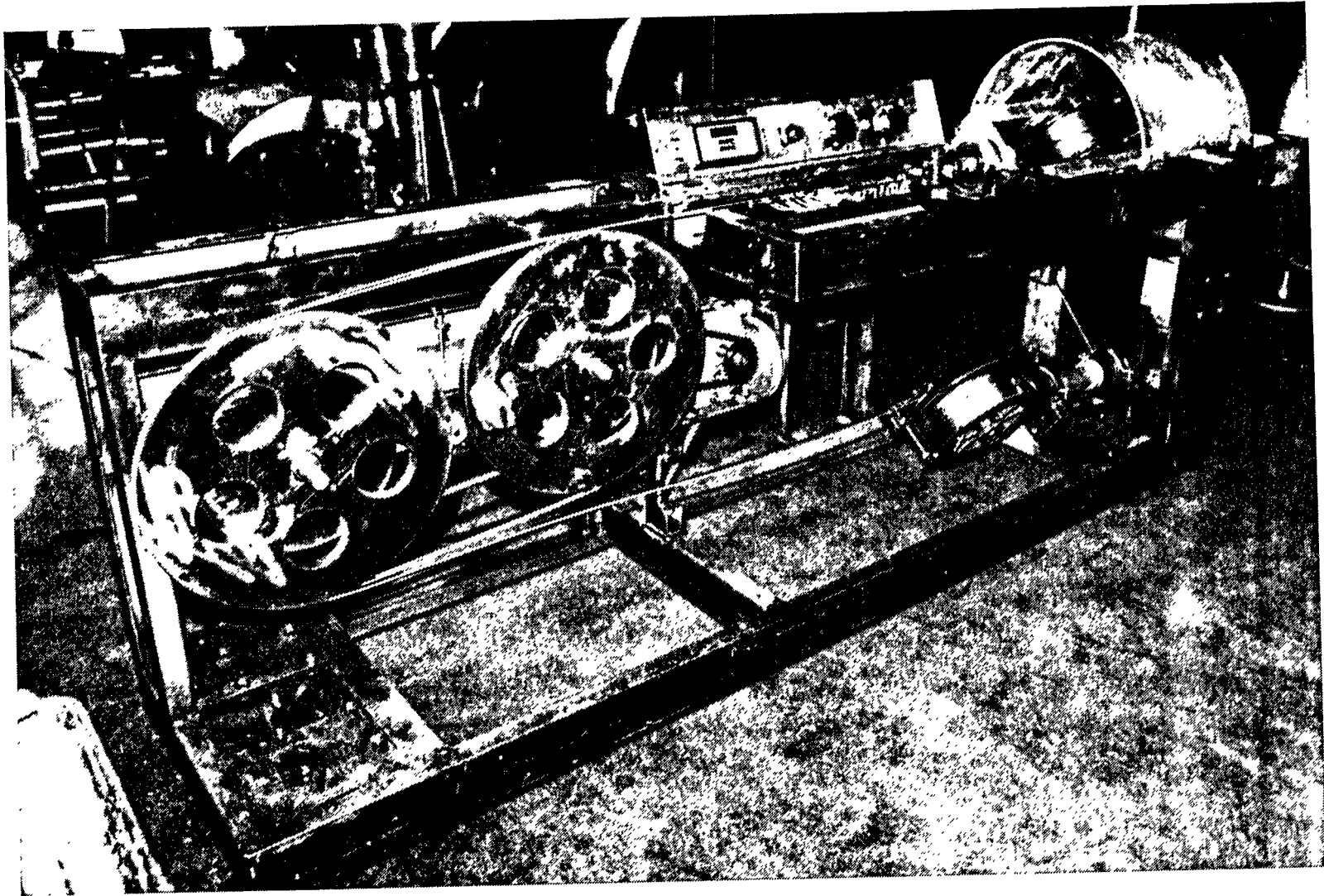

Chart VII. Effects of Voltage for 2x3/32" Flux Cored Electrode



Photograph 1. First Prototype PSNS Wire Twister



Photograph 2. Second Prototype PSNS Wire Twister

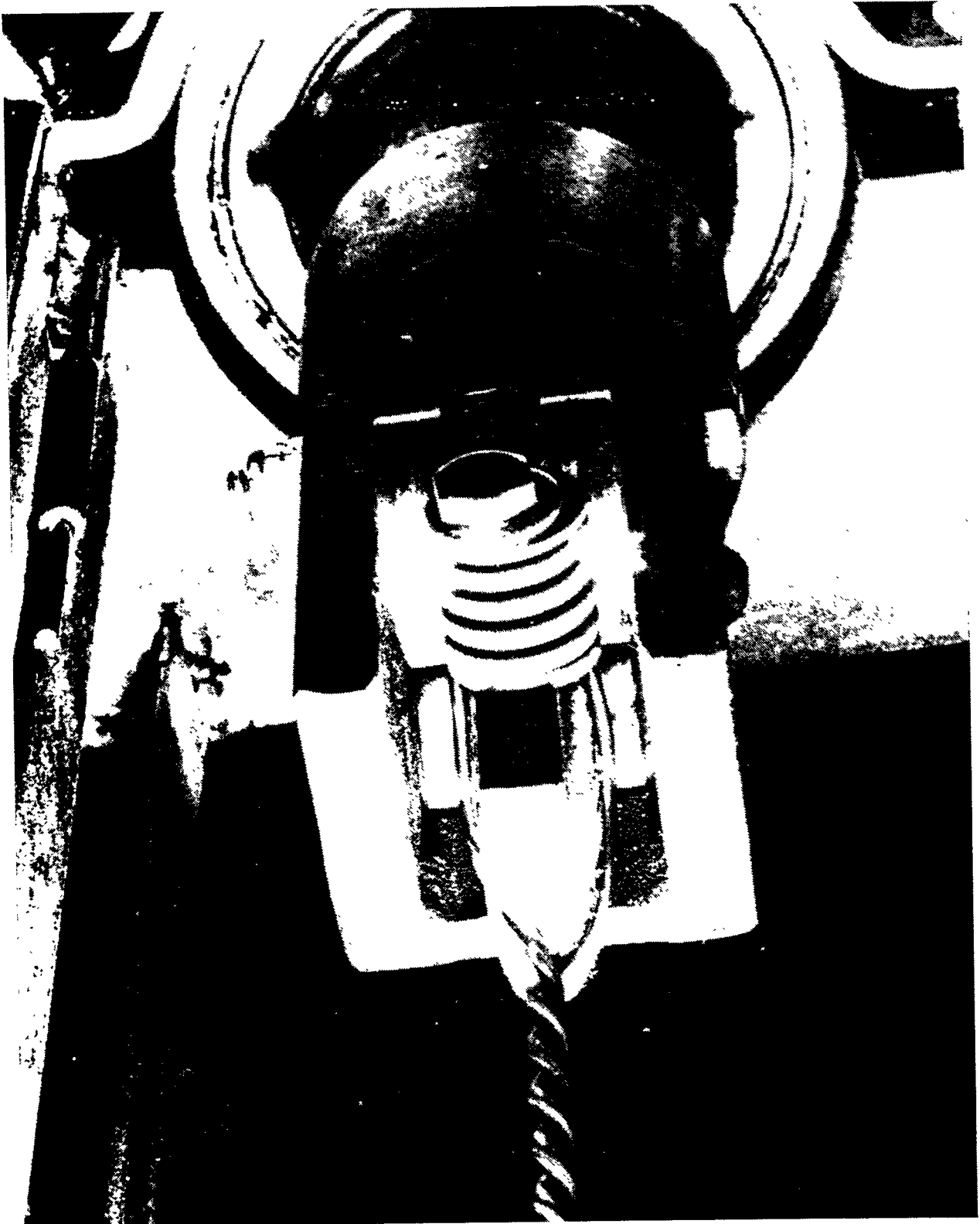

Photograph 3. Tension Equalizer

Twisted 1/16" Diameter Solid Wire Electrode

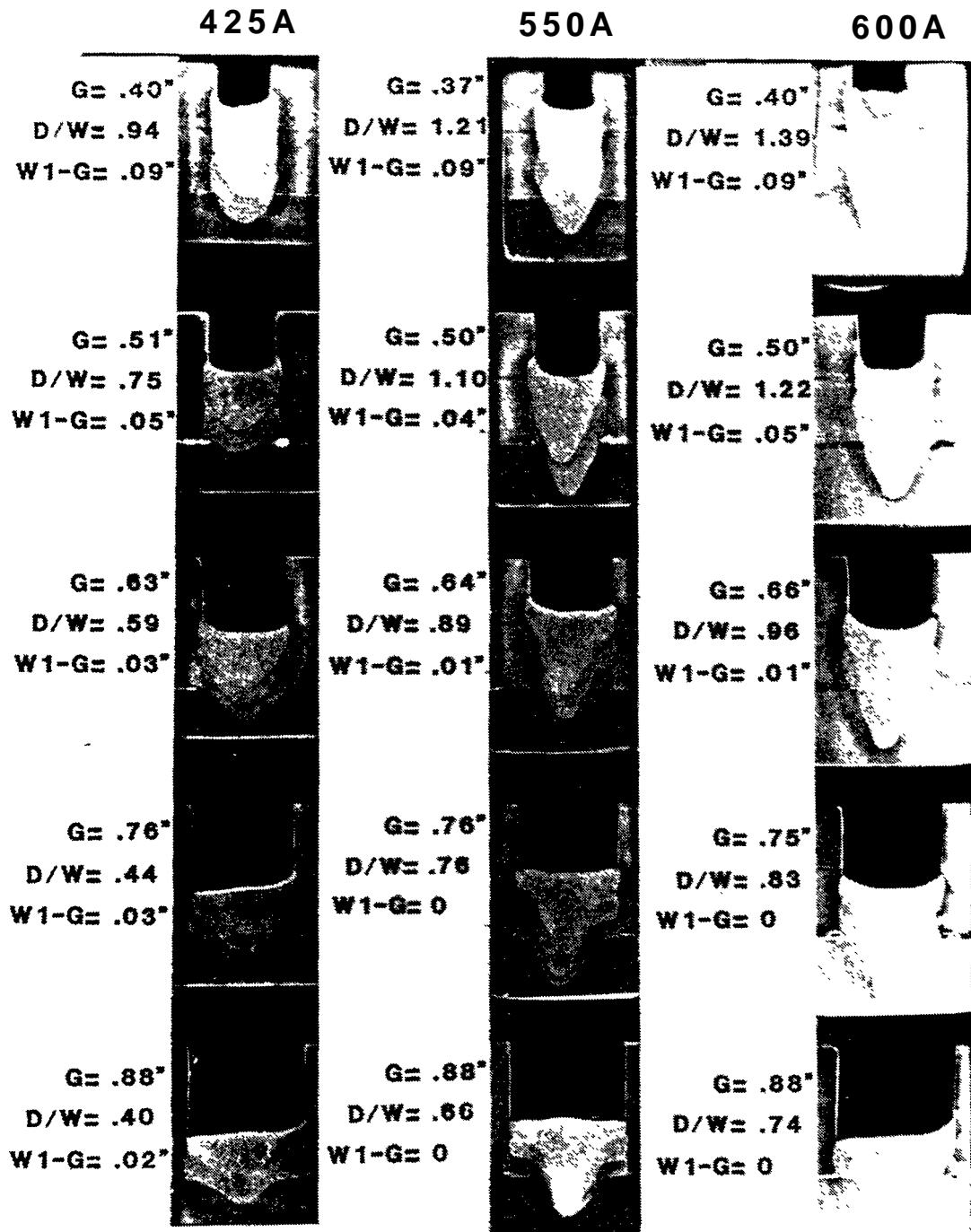

Photograph 4. Cross Sections of 2x1/16" Solid Electrode Welds

Twisted 2mm Diameter Solid Electrode

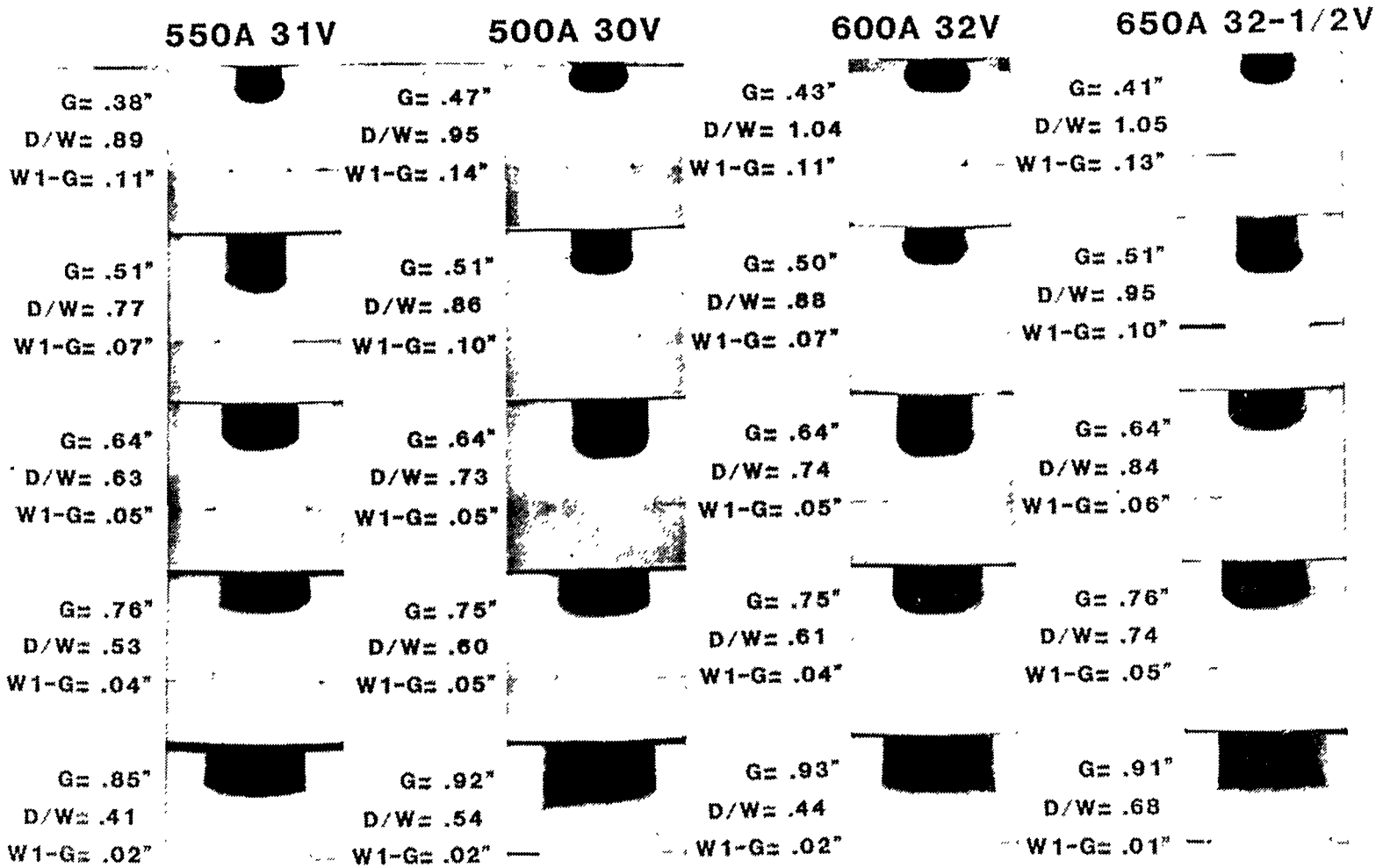

42

Photograph 5. Cross Sections of 2x2 mm Solid Electrode Welds

Twisted 1/16" Diameter Flux Cored Wire Electrode

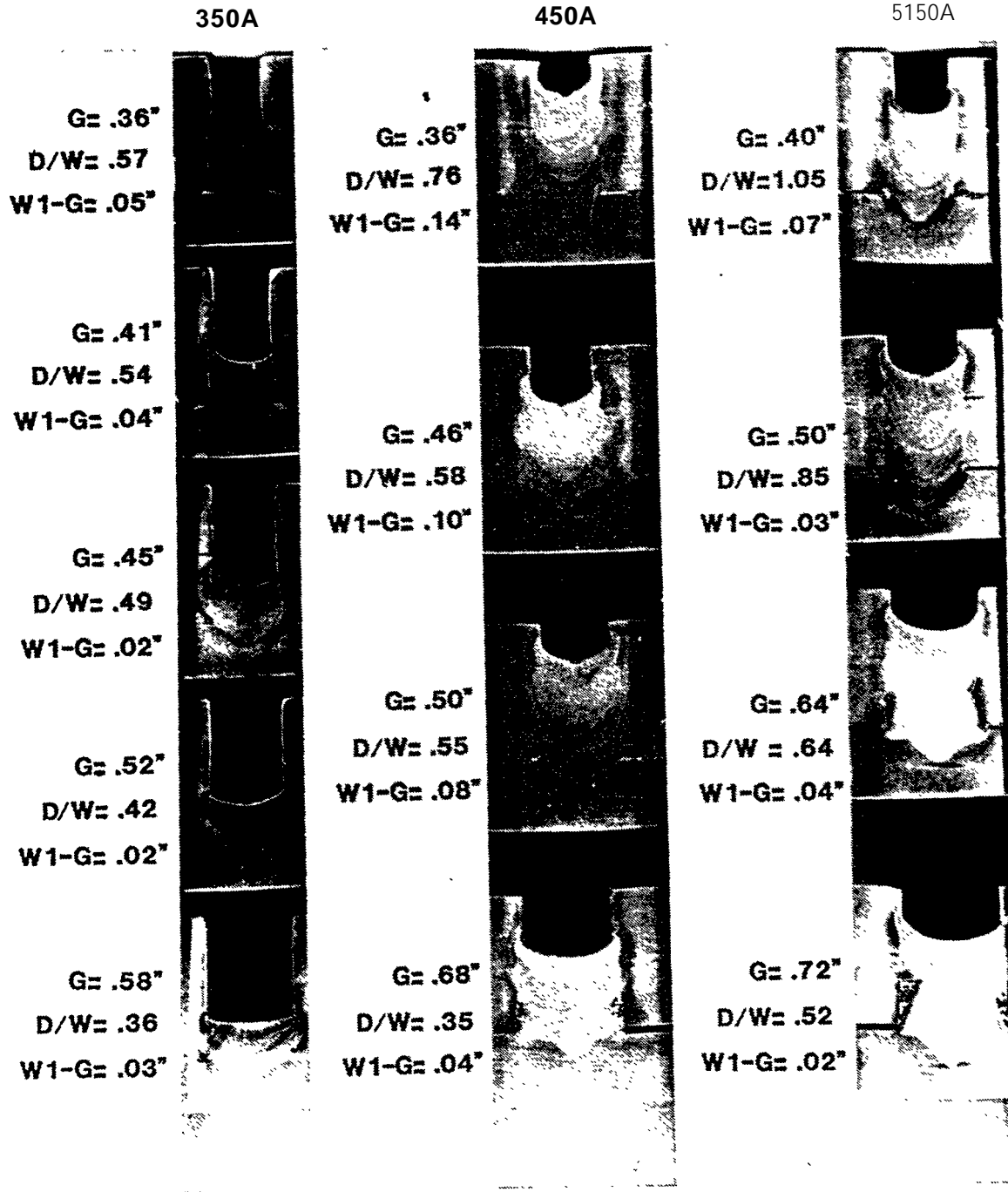

Photograph 6. Cross Sections of 2x1/16" Flux Core Welds

Twisted 3/32" Diameter Flux Cored Electrode

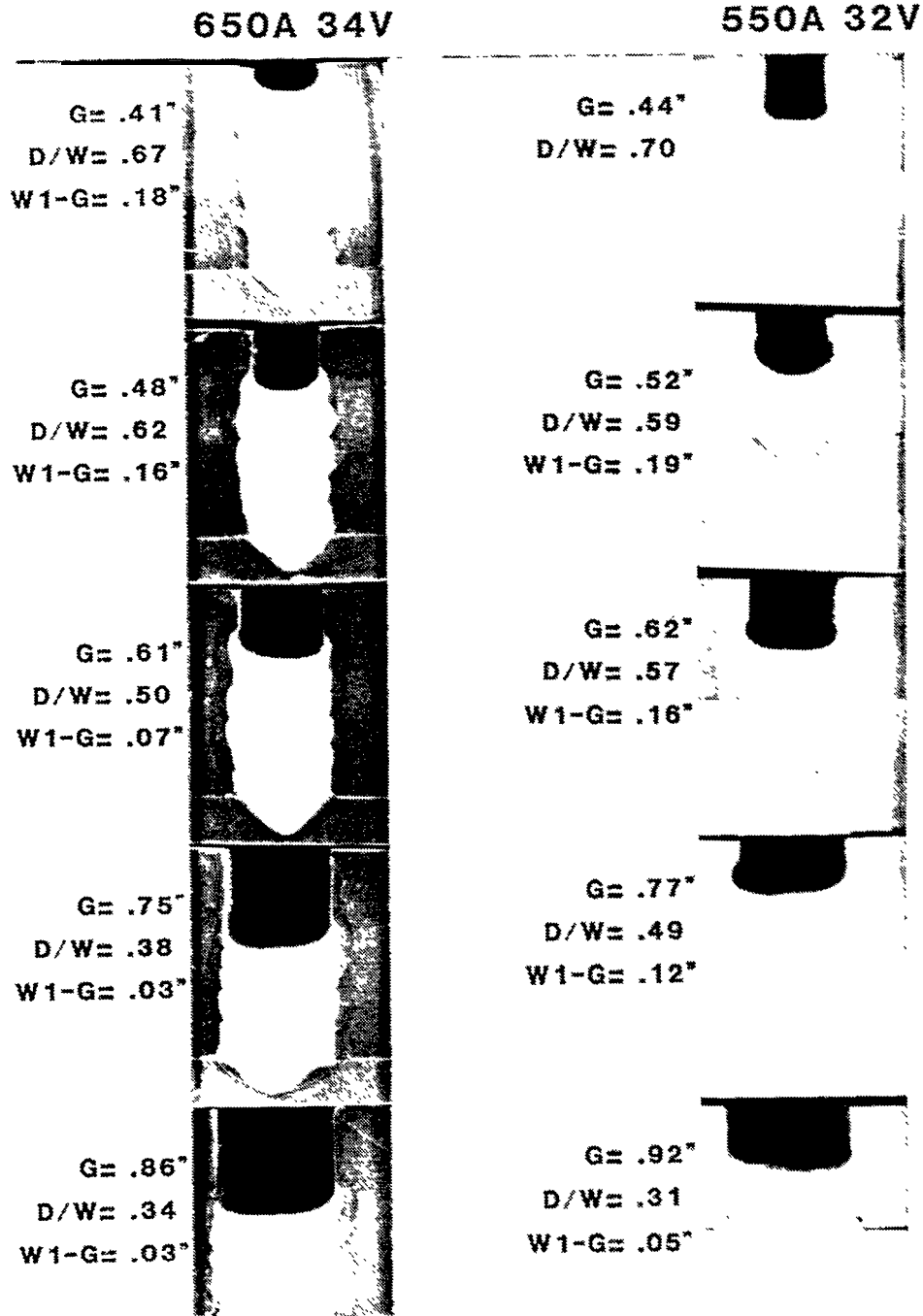

Photograph 7. Cross Sections of 2x3/32" Flux Core Welds

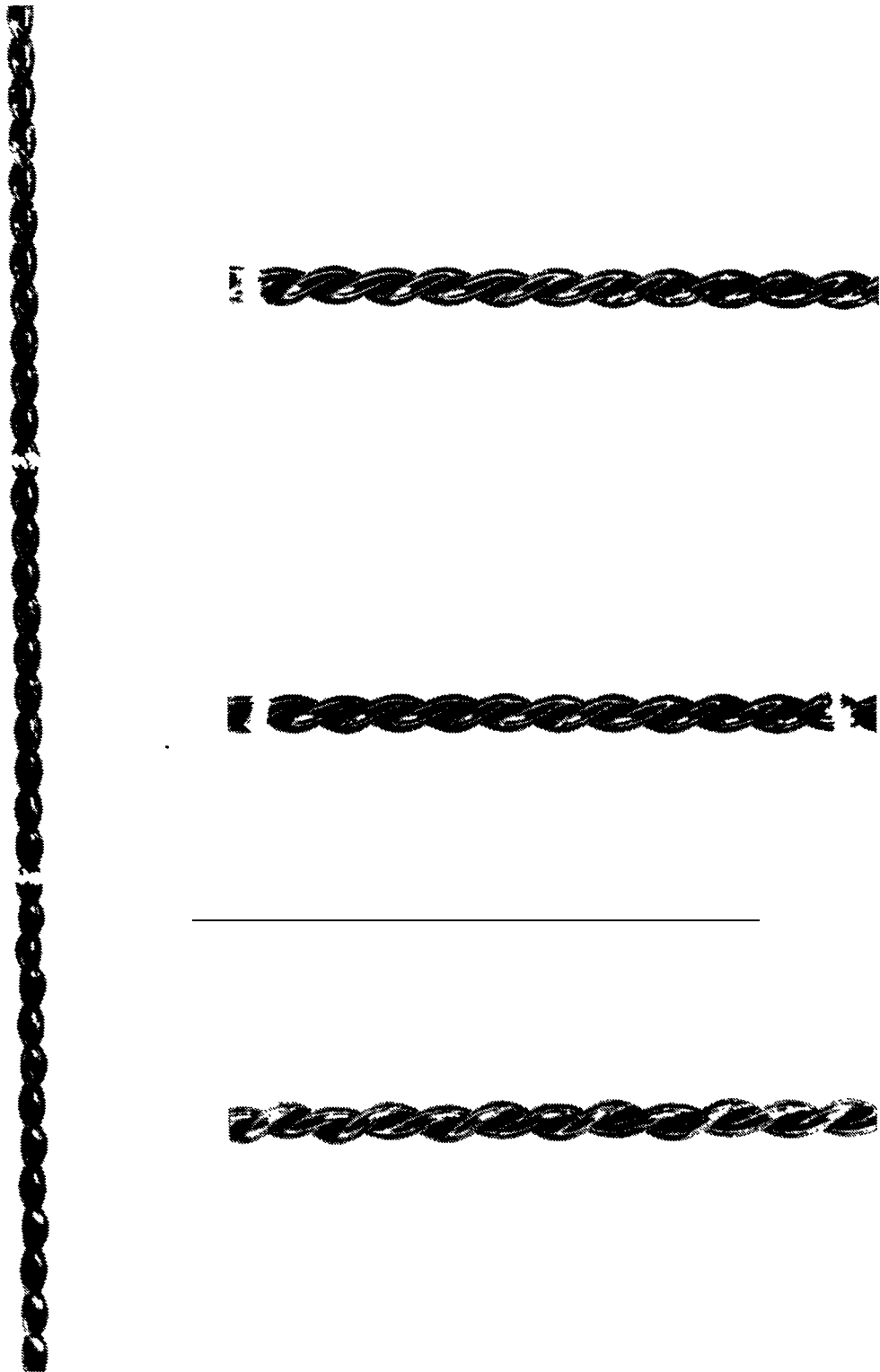

Photograph 8. Wrapping Defects in 2x3/32" Flux Cored Electrode

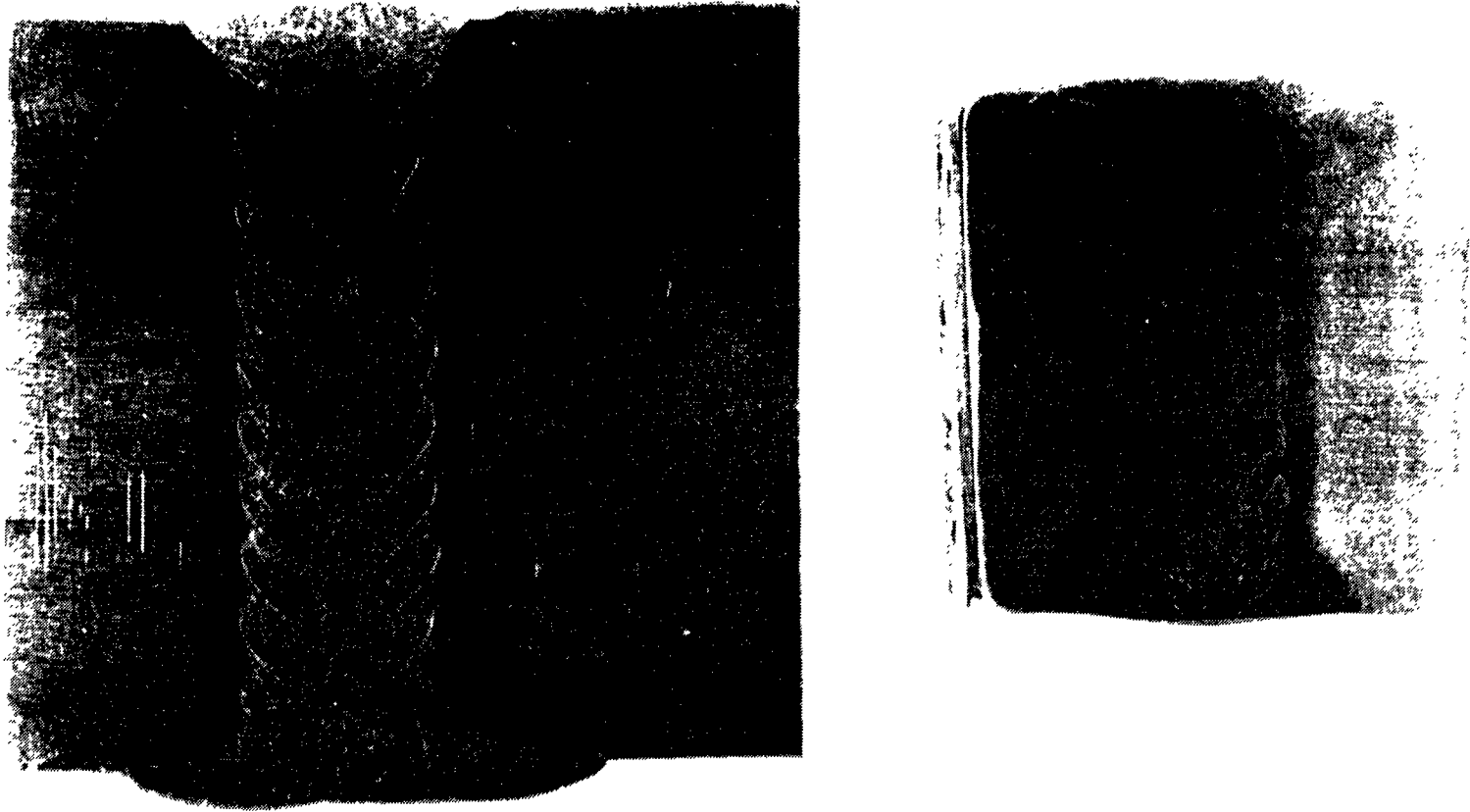

Photograph 9. Macros of Completed Narrow Gap Joints

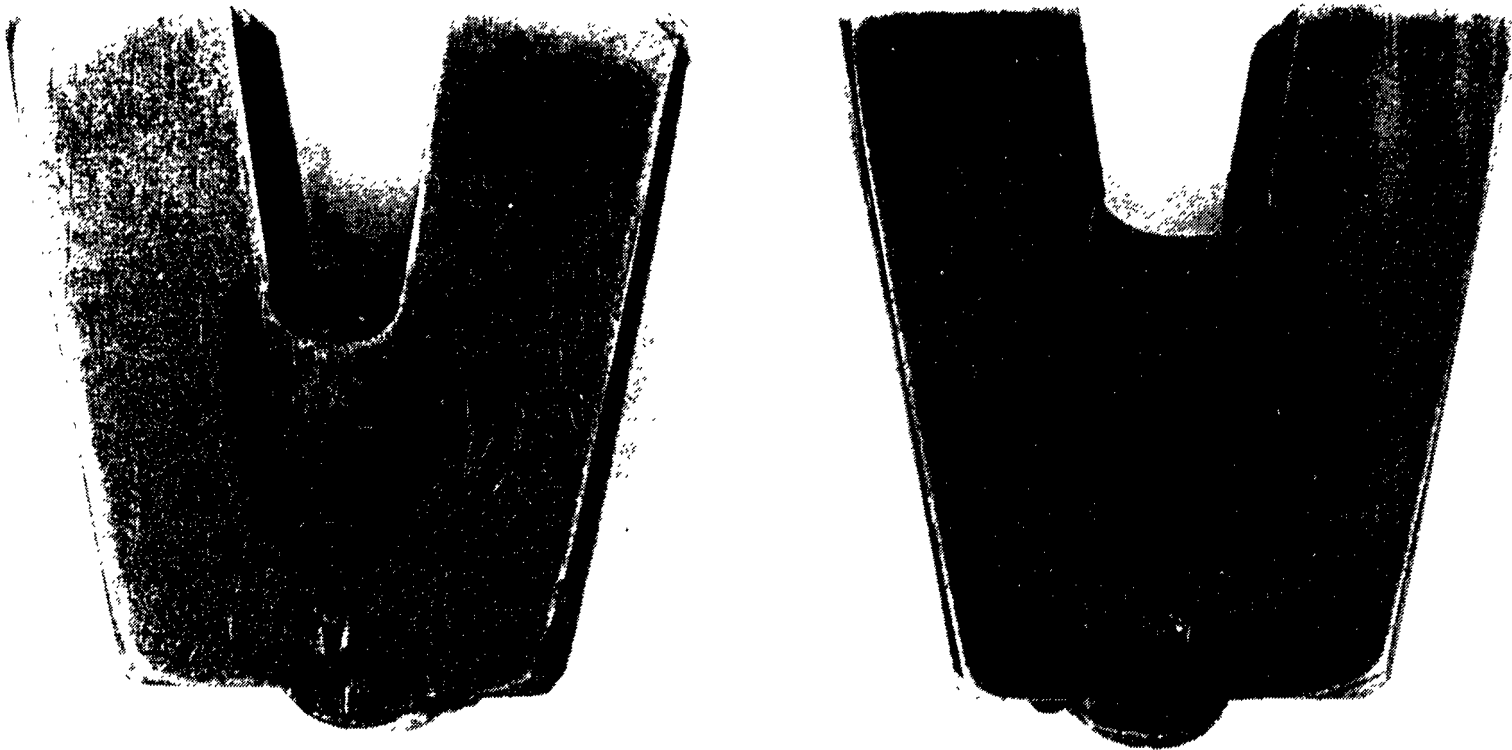

Photograph 10. Welding Over Centerline Cracks with the 2x2mm Solid Electrode.



Photograph 11: Crack-free 2x3/32" Flux Core Weld in a 20° Bevel

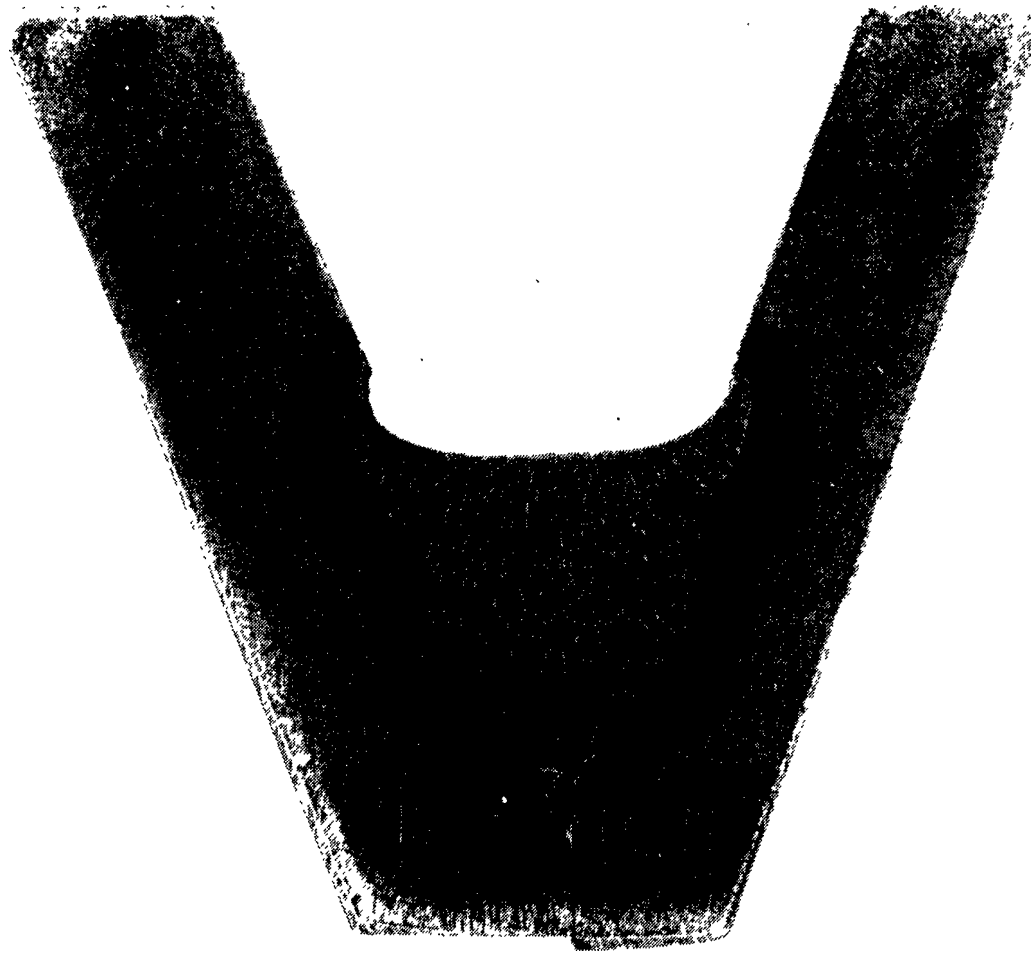

Photograph 12. 2x3/32" Flux Core Weld in a 45° Bevel, 2" Plate

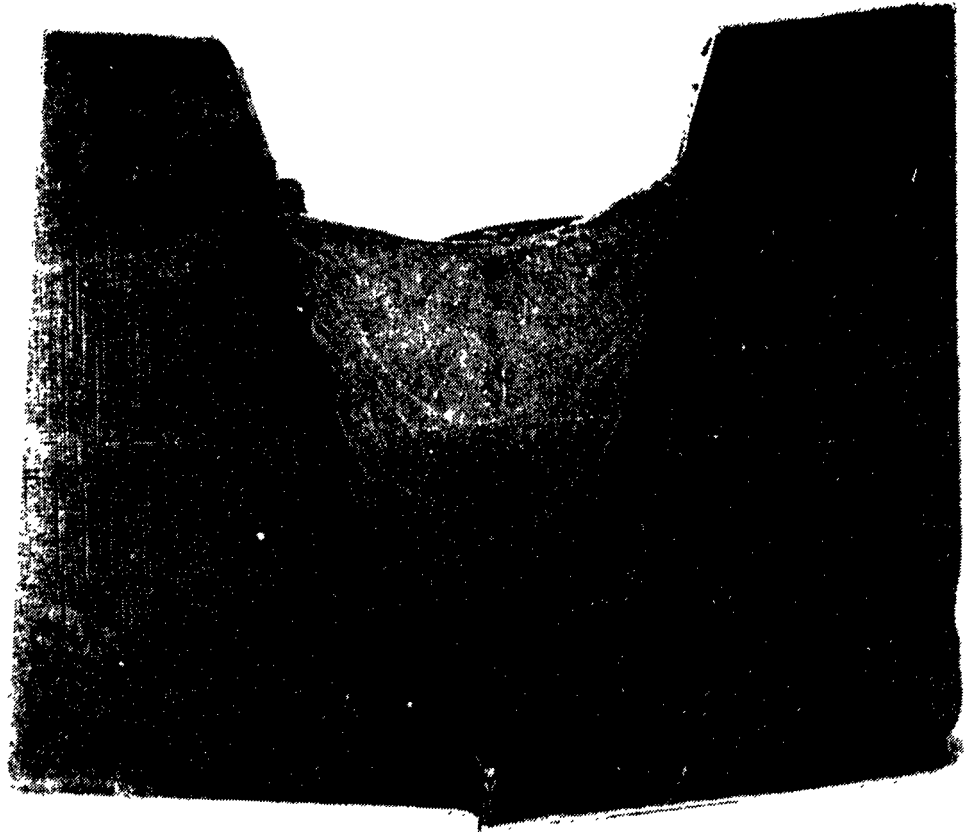

Photograph 13. $2 \times 3/32$ " Flux Core Weld in a 35° Bevel, 2" Plate

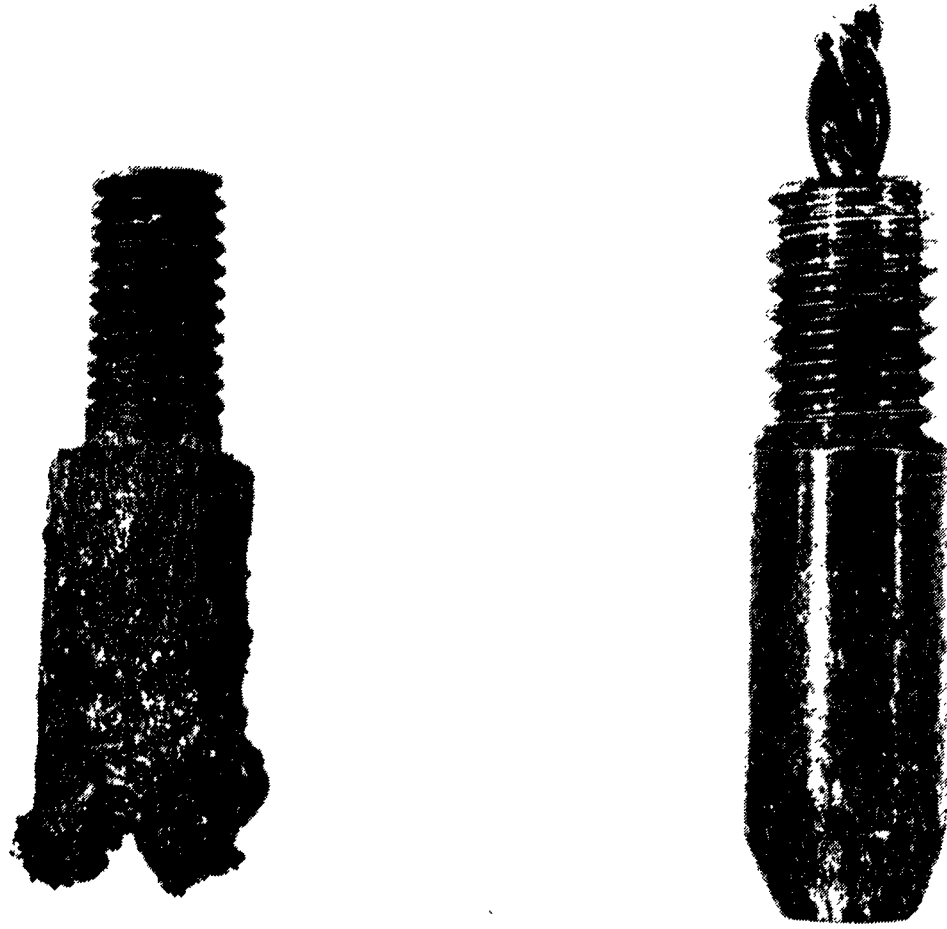

Photograph 14. Contact Tip Life Versus Size of Threaded Conne

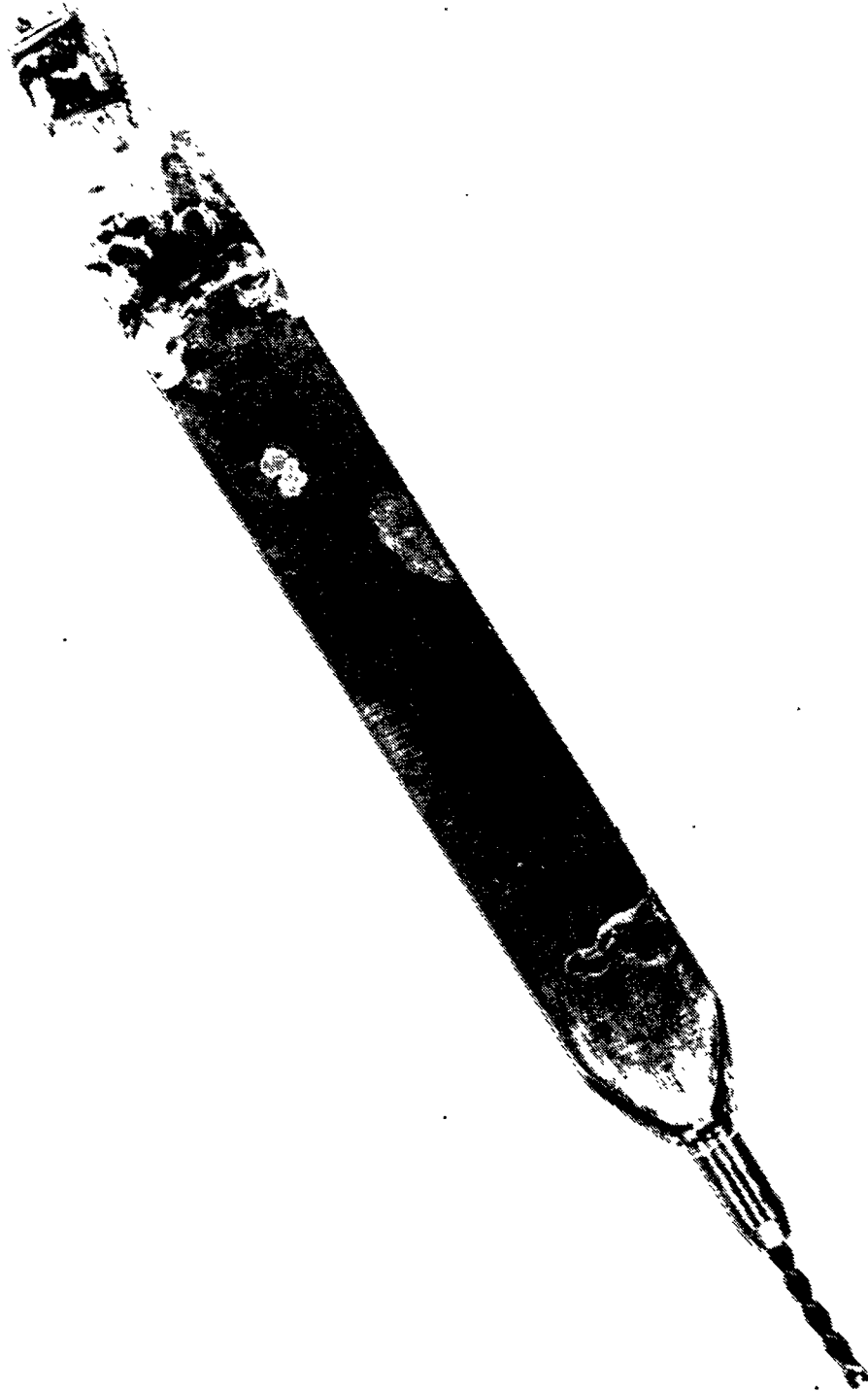

Photograph 15. Thicker Torch to Accommodate Larger Contact Tip Threads

APPENDIX I

WELDING PROCEDURE QUALIFICATION/TEST DATA

1. BASE MATERIAL:

GROUP S3a TO S3a
 PLATE PIPE OTHER
 SPECIFICATION ASTM A 302B TO ASTM A 302B
 GRADE OR CLASS B
 ALTERNATE NA
 LENGTH 42" TO 42"
 WIDTH 124 TO 12"
 THICKNESS 3" TO 3"
 QUENCHED & TEMPERED OR ANNEALED normalized
 HEAT NO. NA

2. FILLER METAL:

Alloy Rods Dual Shield II
 SPECIFICATION AWS A 5.29-80 TYPE E 91 T1-G
 SIZE 2 x 3/32" QC NO. (two intertwined 3/32" dia. wires, 30° twist angle)
 SIZE NA QC NO. NA
 SIZE NA QC NO. NA
 GROUP NO. NA
 CONSUMABLE INSERT SPEC. NA
 TYPE NA SIZE NA
 QC NO. NA

3. FLUX:

TYPE NA GRADE NA
 PARTICLE SIZE NA
 OTHER NA

4. CURRENT

AC DCRP DCSP

5. INERT GAS:

85% Ar 15% CO₂
 SHIELD FLOW 165 CFH
 PURGE NA FLOW NA CFH
 SPECIFICATION

6. BASE METAL CLEANING METHOD:

grind to bright metal

PROCEDURE & NO. 4215

THIS PROCEDURE MEETS THE REQUIREMENTS OF:
MIL-STD-248c

7. WELDING PROCESS:

SINGLE PROCESS MULTIPLE PROCESS
 GMAW SAW
 GTAW SMAW
 FCAW OTHER (SPECIFY) Flux Cored Twist Wire
 MANUAL SEMI-AUTO. AUTO. Narrow Gap

8. POWER SOURCE:

Miller Delta-Weld 650

9. JOINT DESIGN

WELD ONE SIDE ONLY FILLET BUTT
 INSERT BACKING RING REMOVABLE BACKING
 DOUBLE WELDED JOINT
 CLADDING: THICKNESS REQUIRED
 OTHER (SPECIFY) Narrow Gap
 EDGE PREP. METHOD Flame cut

10. WELDING POSITION:

FLAT ROLLED
 HORIZONTAL FIXED
 VERTICAL PROGRESSION
 OVERHEAD RESTRICTION

NO. OF TEST ASSEMBLIES EACH POSITION one

11. TORCH:

MODEL & TYPE Kobe TW-1
 SINGLE, TANDEM ARC single
 OSCILLATION RATE NA CPH, DWELL NA SEC
 AMPLITUDE NA TORCH ANGLE NA
 TORCH OFFSET NA
 TUNGSTEN SIZE NA TYPE NA
 TUNGSTEN EXTENSION NA
 CUP SIZE Kobe TW-1

11/5/85 | FCTW

12. HEAT TREATMENT

PREHEAT TEMP. *300°F* INTERPASS TEMP. *500°F*

MAXIMUM RATE OF HEATING OR COOLING *NA*

PREHEAT DROPPED AFTER WELDING

ANNEAL STRESS RELIEVE, TEMP. *1150 °F*

COOLING: FURNACE AIR OIL WATER

SOLUTION TREAT, SPECIFY:

.505 WELD METAL LONGITUDINAL *NA*

OTHER *NA*

IMPACTS: CHARPY V NOTCH

WELD METAL (LOCATION) *Top - 43, 42 ft-lbs*
Middle - 31, 49, 30, 37, 36; Bottom - 39, 39 ft-lbs

HEAT AFFECTED ZONE (LOCATION) *NA at 520°F*

BASE MATERIAL (LOCATION) *NA*

BASE MATERIAL PRIOR TO WELDING *NA*

TEMPER *NA* OF *NA*

HOLD TIME *3 hrs*

COOLING MEDIUM *furnace cooled above 600°F*

RATE OF HEATING ABOVE 600 °F/H *130 °F*

RATE OF COOLING ABOVE 600 °F/H *200 °F*

13. NONDESTRUCTIVE TESTING:

METHOD	STANDARD	CLASS
<input type="checkbox"/> PT		
<input checked="" type="checkbox"/> RT	<i>N/S 0900-003-9000</i>	<i>1</i>
<input checked="" type="checkbox"/> MT	<i>N/S 0900-003-9000</i>	<i>1</i>
<input type="checkbox"/> UT		
<input checked="" type="checkbox"/> VISUAL	<i>N/S 0900-003-9000</i>	<i>1</i>

LOCATION	METHOD	RESULTS
<input checked="" type="checkbox"/> WELD PREP	<i>visual</i>	<i>sat</i>
<input checked="" type="checkbox"/> ROOT	<i>visual, MT</i>	<i>sat</i>
<input checked="" type="checkbox"/> EACH LAYER	<i>visual</i>	<i>sat</i>
<input type="checkbox"/> 1/2 THICKNESS		
<input checked="" type="checkbox"/> BACKGOUGE	<i>visual, MT</i>	<i>sat</i>
<input checked="" type="checkbox"/> FINAL	<i>visual, MT, RT</i>	<i>sat</i>

METALLOGRAPHIC: *NA*

MACRO MICRO MAGNIFICATION *10X*

NO. OF SAMPLES EACH ASSEMBLY *three no discontinuities found*

CHEMICAL ANALYSIS:

BASE MATERIAL

WELD MATERIAL (LOCATION)

CLADDING (LOCATION) *NA*

ANALYZED FOR: *NA meets specification*

14. DESTRUCTIVE TESTING:

TYPE	NUMBER	RESULTS
<input type="checkbox"/> FACE, TRANSVERSE		
<input type="checkbox"/> FACE, LONGITUDINAL		
<input type="checkbox"/> ROOT		
<input checked="" type="checkbox"/> SIDE, TRANSVERSE	<i>3</i>	<i>sat. (no fissures or open defects)</i>
<input type="checkbox"/> SIDE, LONGITUDINAL		

TENSILE:

REDUCED SECTION (TRANSVERSE) *two sat.*

tensile, psi - 100,000; 94,200 fractured in base metal

15. WELDER/WELDING OPERATOR:

NAME	BADGE
<i>Van Ginke/157863 + McElwee 156677</i>	

REMARKS

in base metal

11/7/85 FCTW

SKETCH OF JOINT

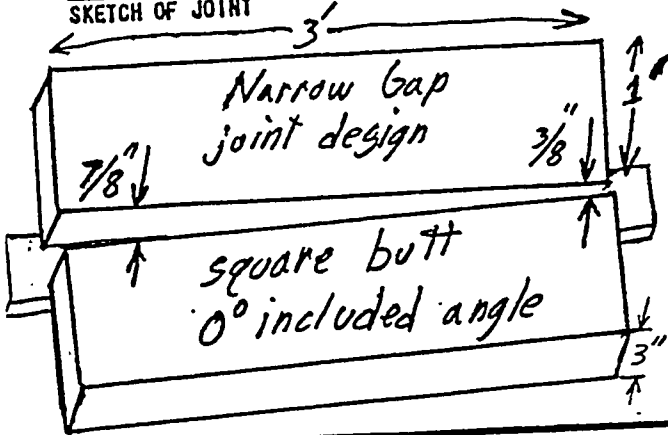

BEAD SEQUENCE

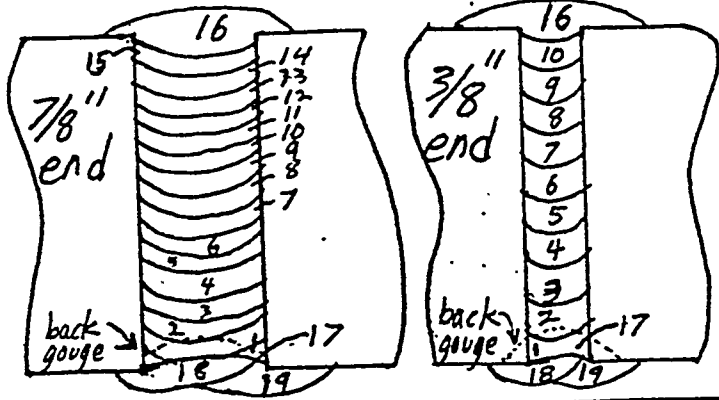

PARAMETERS

Shielding Gas

PASS NO.	ELECTRODE SIZE	FILLER SIZE	AMPS	VOLTS	WIRE FEED	TRAVEL SPEED	Shielding Gas	
							inner	outer
1	2 x 3/32"	NA	600	28		9 ipm	65 cph	100
2	2 x 3/32"	NA	625	29		9	65	100
3	2 x 3/32"	NA	600-625	28 1/2		9	65	100
4	2 x 3/32"	NA	600-625	29-29		9	65	100
5	2 x 3/32"	NA	600-625	28-29		9	65	100
6	2 x 3/32"	NA	600-625	25		9	55	110
7	2 x 3/32"	NA	600-625	26		9	55	110
8	2 x 3/32"	NA	600-625	26 1/2		9	55	110
9	2 x 3/32"	NA	600-625	26 1/2		9	55	110
10	2 x 3/32"	NA	600-625	26-27		9 10	55	110
11	2 x 3/32"	NA	600-625	26-27		9 10	55	110
12	2 x 3/32"	NA	600-625	26		9 10	50	80
13	2 x 3/32"	NA	600-625	26		9 10	50	80
14	2 x 3/32"	NA	600-625	26-27		9 10	50	80
15	2 x 3/32"	NA	600-625	26-27		9 1/2	50	80
16	2 x 3/32"	NA	600-625	26-27		9 1/2	50 NA	80 NA
17	Back gouge	NA	NA	NA	NA	9 1/2	50	80
18	2 x 3/32"	NA	575-675	28		12	50	80
19	2 x 3/32"	NA	575-675	26-27		12	50	80

3/8" end filled

7/8" end filled (cover pass)

(cover pass)

NOTES/REMARKS

THE ACTION TO BE VERIFIED IS THAT THE REQUIRED OPERATIONS HAVE BEEN COMPLETED WITH SATISFACTORY RESULTS. IT IS NOT INTENDED THAT THE DESIGNATED PERSON NECESSARILY OBSERVE ALL THE WORK, BUT HE SHOULD HAVE OBJECTIVE EVIDENCE, SUCH AS DATA SHEETS, INSPECTION REPORTS, CERTIFICATION STICKERS OR TAGS, WELD RECORDS, ETC. THAT WORK WAS DONE PROPERLY.

TEST DATA VERIFIED BY
Sarah A. Montfort 11/7/85
 APPROVED HEAD WELDING ENG. DIV.
Frank B. Gatta for 12/5/80
 PAGE 3 OF 3

TO	CODE/SHOP 138.2	NAME Mortvedt/Hatto	JOB ORDER 81452-10001-000
SUBJECT Charpy Impact Test			
SUBJECT MATERIAL Gleed Pored Twisted Wire			
DRAWING NO. NA	PIECE NO. M-T-B	ACCEPTANCE SPECIFICATION	PROCEDURE AGAINST 4730.26
TESTS	<input type="checkbox"/> CHEMICAL	<input type="checkbox"/> SPOT TEST	<input type="checkbox"/> HARDNESS
	<input type="checkbox"/> MICRO	<input type="checkbox"/> SPRING LOAD	<input type="checkbox"/> PROOF LOAD
		<input type="checkbox"/> TENSILE	<input type="checkbox"/> BEND
		<input type="checkbox"/> BREAKING LOAD	<input checked="" type="checkbox"/> OTHER CHARPY

DESCRIPTION AND/OR SKETCH

Few Charpy impact specimens were tested as requested by Code 138.2. Values are listed below.

TEST RESULTS AND REMARKS

ACCEPT REJECT INFORMATION

Tests were conducted at -20°F.

<u>M</u>		<u>B</u>		<u>T</u>	
1.	31	1.	39	1.	43
2.	49	2.	39	2.	42
3.	30	3.	39		
4.	37				
5.	36				

Values recorded are stated in ft. lbs.

OPERATOR (SIGNATURE) Judith McKinney	DATE 11/21/85	REVIEWER (SIGNATURE) L.S. Decker	DATE 11-21-85
DISTRIBUTION:			



DEPARTMENT OF THE NAVY
NAVAL SEA SYSTEMS COMMAND
WASHINGTON, D.C. 20362-5101

IN REPLY REFER TO
9074
OPR:05M2
Ser 05M2/395
18 DEC 1987

From: Commander, Naval Sea Systems Command
To: Puget Sound Naval Shipyard (Code 138)

Subj: QUALIFICATION DATA FOR TWISTED WIRE WELDING PROCEDURE

Ref: (a) Puget Sound Ltr, 9074, Ser 138/201-85

1. The qualification data for the subject procedure submitted in reference (a) is considered acceptable using the procedure specifically developed for this process.
2. The narrow gap twisted wire procedure is considered acceptable for weld, subject to 100 percent radiographic inspection. Use on other welds would be subject to separate approval by the Naval Sea Systems Command.

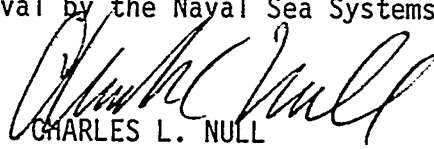
CHARLES L. NULL
By direction

APPENDIX II

FLUX CORED TWIST WIRE WELD PROCEDURE SPECIFICATION FOR
MANGANESE MOLYBDENUM TANKS AND JOINT DESIGNS

1. THIS SPECIFICATION CANCELS AND SUPERSEDES WELDING PROCEDURE SPECIFICATIONS NO. 4215 REV. orig.

WELDING PROCEDURE SPECIFICATION
 2. DATE 5/22/86 3. NO. 4215 rev. 1

4. SUBJECT MANGANESE MOLYBDENUM STEAM ACCUMULATOR TANKS (FLUX CORED TWIST WIRE)

5. WELD PROCESS FCTW 6. POWER SOURCE D.C. Rectifier or equiv. 7. WELD POSITION & PROGRESSION Flat

8. BASE METAL (SPECIFICATION & THICKNESS) ASTM-A-302 gr. B or -508 cl.2 or equiv. 3/16" to 4" 9. SHIELDING GAS/FLOW RATE RANGE 50 cfh minimum

10. FILLER METAL (SPECIFICATION & DIAMETER) 2x1/16" and Alloy Rods Dual Shield II 100D-1 2x3/32" Twisted 11. PURGING GAS/FLOW RATE RANGE N/A

12. ELECTRICAL CHARACTERISTICS			POLARITY	DCRP	13. TUNGSTEN (TYPE & SIZE)
PASS NO.	ELEC. SIZE	AMPERAGE		VOLTAGE	
					N/A
					14. TORCH
					ST-12 or equivalent
					15. CUP SIZE
					3/4" minimum
					16. TRAVEL SPEED
					see page 3

17. PREHEAT & INTERPASS TEMPERATURE 300 °F MIN. 500 °F MAX. 18. WIRE FEED RANGE N/A

19. POST WELD HEAT TREATMENT Wet Accumulator Fabrication and Heat Treat Procedure 20. WELDER QUALIFICATION Per Procedure 4155

21. CLEANLINESS.
 THE WELD JOINT AREA, PLUS 1/2" OF SURROUNDING BASE METAL SHALL BE FREE OF ANY FOREIGN MATERIAL, SUCH AS OIL, GREASE, MOISTURE, PAINT, LAY-OUT DYE, ETC. APPROVED CLEANERS SUCH AS ALCOHOL, FREON 13 OR 11 MAY BE USED TO REMOVE GREASE AND OIL. MECHANICAL CLEANING MAY ALSO BE USED.

22. JOINT DESIGN, FIT-UP AND PREPARATION

 see page 2

23. TYPICAL BEAD SEQUENCE

 see page 2

24. INSPECTION:
 A. PRIOR TO WELDING: VISUALLY INSPECT FIT-UP JOINT FOR CLEANLINESS AND JOINT DESIGN COMPLIANCE.
 B. DURING WELDING: VISUALLY INSPECT EACH PASS. TEMPERATURE INDICATING CRAYONS SHALL NOT BE USED ON WELD OR BASE MATERIAL WHICH WILL BE WELDED OVER. ALL WELD DEFECTS SHALL BE REMOVED.
 C. AFTER WELDING: VISUALLY INSPECT THE FINISHED WELD.
 D. VISUAL INSPECTION: ALL VISUAL INSPECTIONS SHALL BE IN ACCORDANCE WITH NAVSHIPS 0900-003-8000 CLASS 1
 E. ADDITIONAL INSPECTIONS SHALL BE AS REQUIRED BY PDM, NPEI, OR OTHER AUTHORIZED INSTRUCTIONS.

25. REMARKS AND/OR NOTES:

 All requirements not covered by this procedure shall be as specified in Weld Procedure 4155.

PREPARED BY (SIGNATURE) <i>Joseph A. Montvett</i>	BRANCH HEAD REVIEW (SIGNATURE) <i>Frank B. Gath</i>	DISTRIBUTION C/138, C/280.3, S/26
APPROVED BY WELDING ENGINEERING DIVISION HEAD (SIGNATURE) <i>Ed. Calvez</i>		WELDING PROCEDURE SPECIFICATION
WELDING PROCEDURE SPECIFICATION 13ND PSNS 10310/3 (REV. 4-75)		DATE <u>5/22/86</u> NO. <u>4215 rev.1</u>

JOINT DESIGN

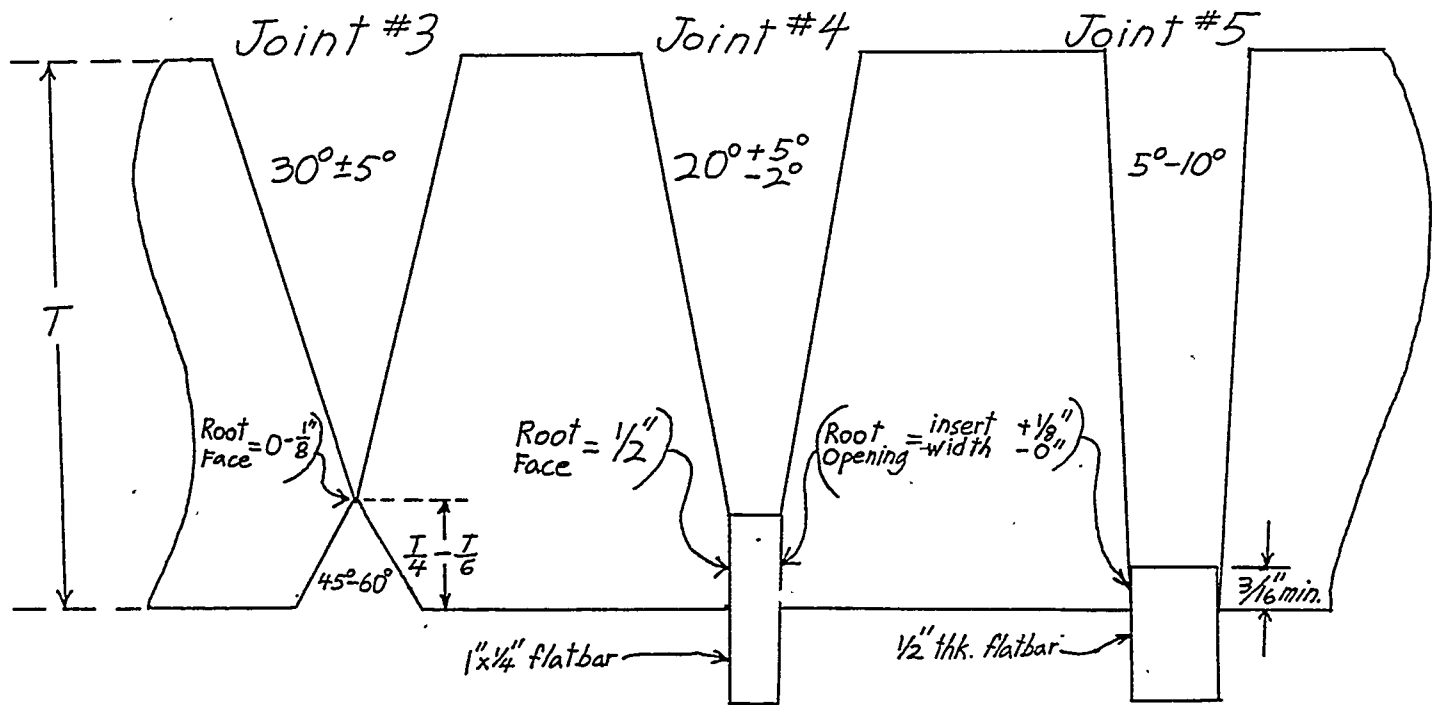
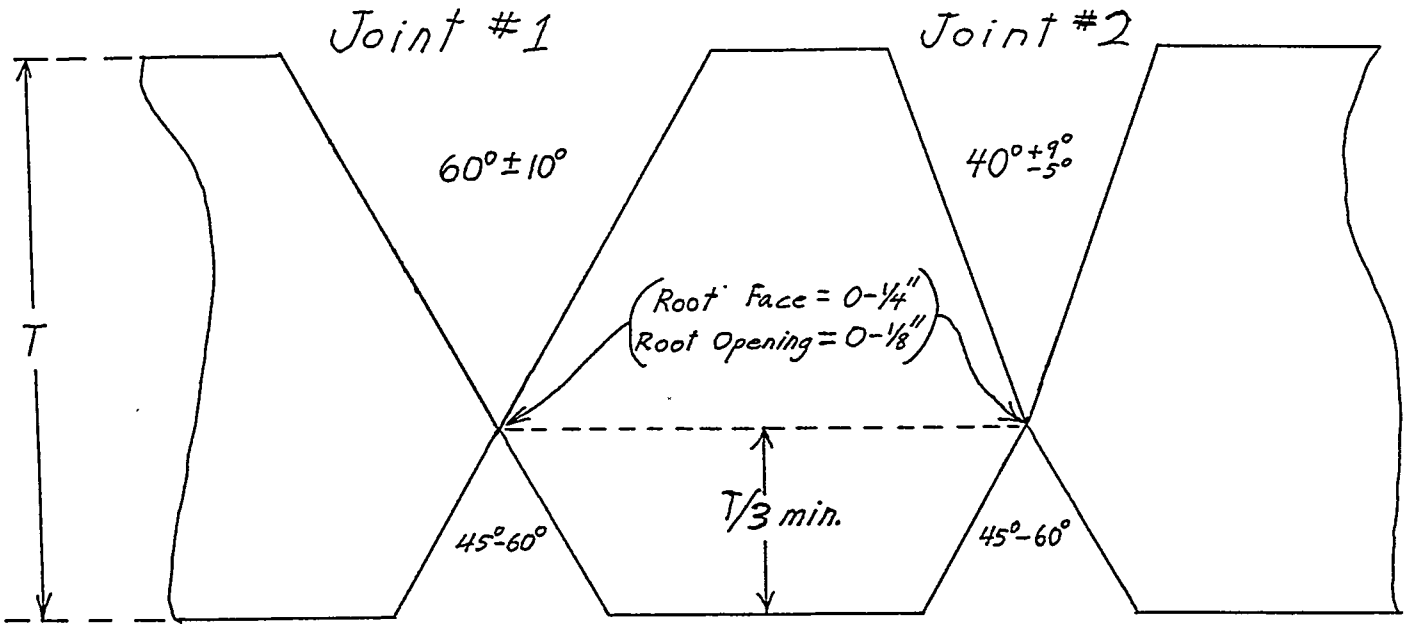

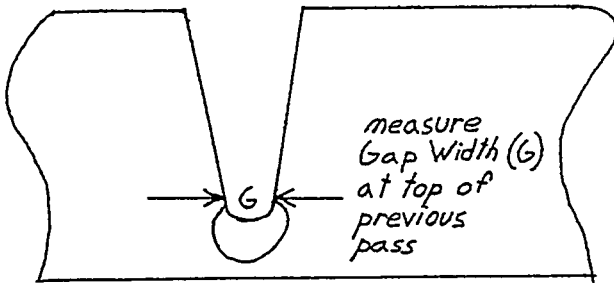

PARAMETER RANGES FOR 2x1/16" TWIST WIRE

Gap Width (G)	Amperage	Voltage	Travel Speed (ipm)	Stickout
root pass	425 max	25 min	8-11	1"-1 3/8"
1/4"-1/2"	350-375	25-27	10-12	
1/4"-1/2"	376-400	25-28	10-12	
3/8"-5/8"	401-425	26-29	10-12	
3/8"-5/8"	426-450	26-29	10-12	
1/2"-11/16"	451-475	26-30	10-11	
1/2"-11/16"	476-500	27-30	10-11	
1/2"-11/16"	501-525	27-31	10-11	
9/16"-11/16"	526-550	28-32	10-11	

PARAMETER RANGES FOR 2x3/32" TWISTED WIRE

Gap Width (G)	Amperage	Voltage	Travel Speed (ipm)	Stickout
root pass	575 max	26 min	10-11	1 1/4"-1 7/8"
3/8"-3/4"	550-575	26-29	10-12	
1/2"-3/4"	576-600	27-30	10-12	
1/2"-7/8"	601-625	28-31	10-11	
5/8"-7/8"	626-650	28-32	10-11	
5/8"-7/8"	651-675	29-33	10-11	
3/4"-7/8"	676-700	30-34	10-11	
Cover Passes or 2 Pass per Layer Fill Passes	600-625	28-31	13-20	
	626-650	28-31	13-20	
	651-675	29-33	14-20	
	675-700	30-34	14-20	

APPENDIX III

KOBE TW - 1 EQUIPMENT

TW-1

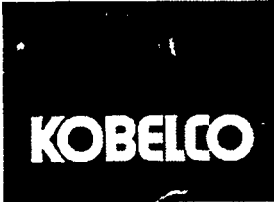
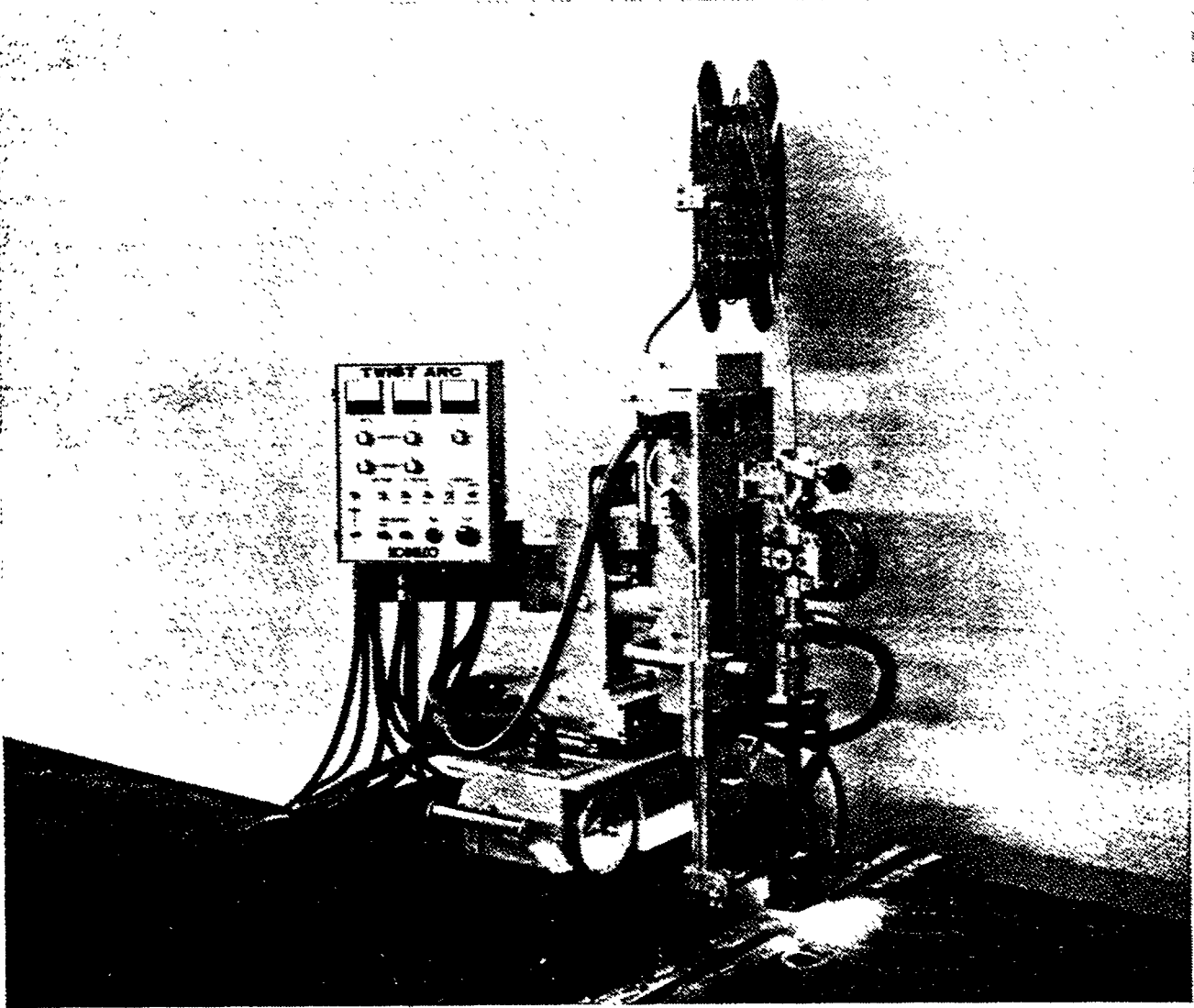

TW-1

TWIST ARC Welding Equipment "T W - 1" demonstrates the best reliability and economy in the TWIST ARC welding process.

Features

Easy operating welding equipment because of its simple structure.

For conventional narrow gap welding equipment it is necessary to bend the wire and to have oscillation in order to penetrate a narrow gap wall. But, with this equipment using a special wire of two threaded wires, such a function is not required and by simply feeding the wire into the center of the narrow gap, narrow gap welding can be performed at a high reliability.

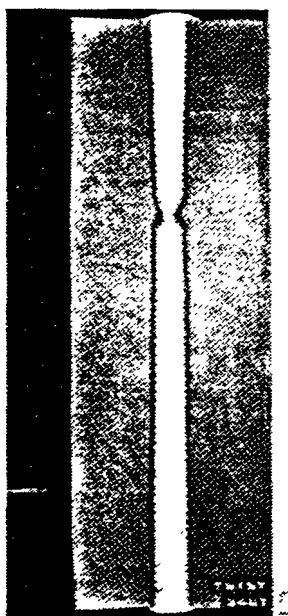

- Up to 300mm thick welding is available because the location of the long stroke torch can be adjusted up and down.
- Torch location can easily be adjusted in the narrow gap with just observing the arc by a remote pendant box which can be held in one hand.
- Being removable from the travel carriage, the welding head of TW-1 can be easily mounted on the manipulator.

TWIST ARC Welding Method means

This is a method which naturally causes swing and rotation movement of the welding arc generated from the ends of two intertwined wires, thus assuring sufficient penetration into the narrow gap wall, assuring attainment of concaved bead surface shape and preventing blow holes inherently occurring in MIG welding, because of the effects of active convection and mixture of molten metal characteristic of the above-mentioned movement.

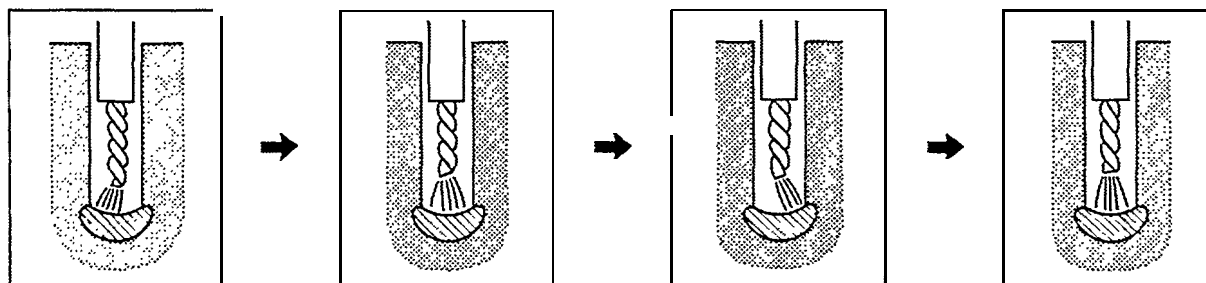

Swing and rotation of welding arc

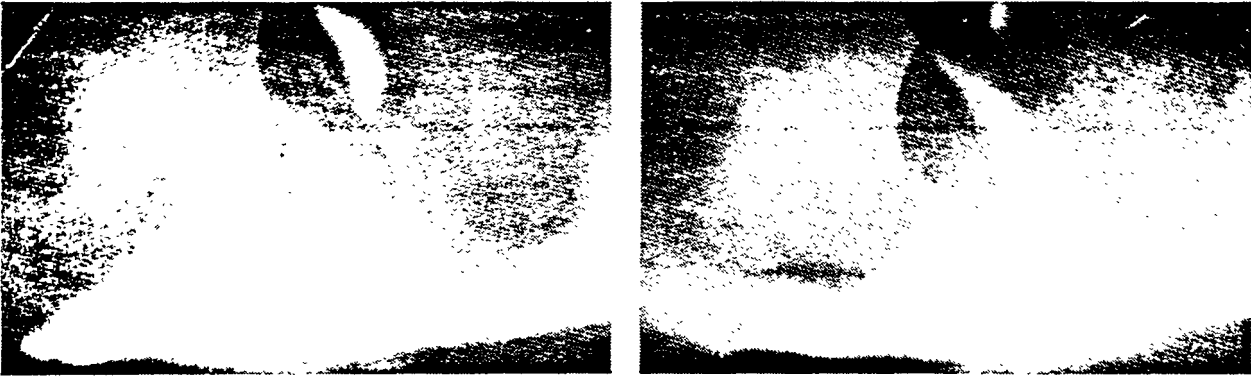

Generating status of welding arc
(as shown by high-speed film)

Features of the TWIST ARC Welding Method

- o Highly Efficient and Economical

Because the cross-section of a gap welded by the TWIST ARC is smaller than that welded by Submerged Arc, this method is economical as well as highly efficient.

- o High Reliability with a Simple Operation

Because of the above mentioned features of TWIST wire, sufficient penetration into the narrow gap wall easily be obtained, and by roughly adjusting the wire feeded point to the center of the narrow gap, highly reliable welding can be performed.

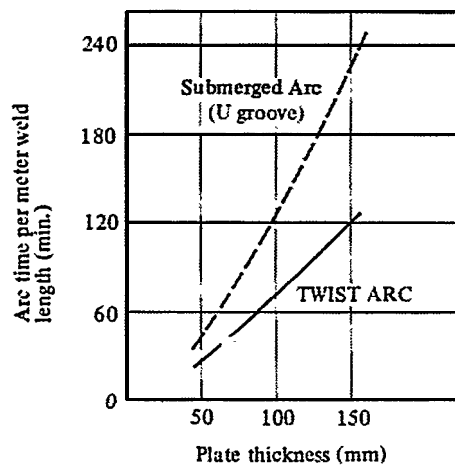

A comparison of welding arc time

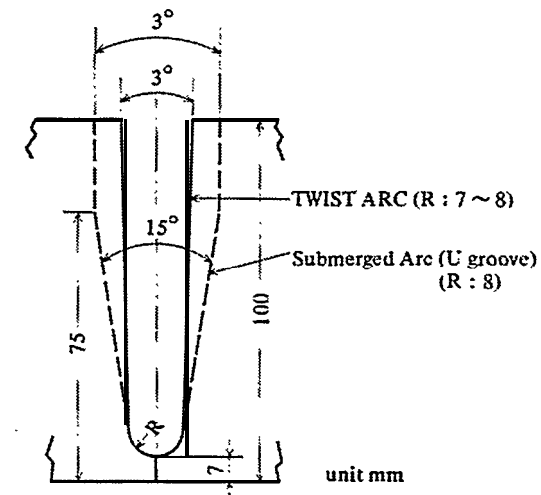

An example of narrow gap shape

Application

- Applicable position Flat position
- Applicable plate thickness Max. 300 mm
- Applicable material Mild steel ~ 80 kg/mm² class high tensile steel. low-alloy steel for boiler and pressure vessel application
- Groove width 14 $\begin{matrix} +4 \\ -5 \end{matrix}$ mm (I, J and U form)
- Applicable joints Circumferential and longitudinal butt joints for boiler and pressure vessel.
Butt joints of thick plate for hydraulic power generator, heavy machinery. etc.

Typical Welding Conditions

- Welding current : 500~550A
- Welding voltage : 29~32V
- Welding speed : 20~40 cm/min.
- Shield gas : 80% Ar + 20% CO₂
 - For shield gas nozzle
 - Primary gas : 5 ~ 10 ℓ/min.
 - Secondary gas : 50 ℓ/min.
 - For shield gas box
 - Primary gas : 50 ~ 60 ℓ/min.
 - Secondary gas : 50 ~ 60 ℓ/min.

Components and Specifications

Components		Specifications
Travel Carriage	Travelling method	Rail guide friction method
	Travel speed	1.5 ~ 85 cm/min. (5.9 ~ 33.5 inch/min.)
	Clutch	A manual clutch
	Dimensions and weight	330W × 760D × 175H mm 39Kgf (13.0W × 29.9D × 6.9H inch, 86 lbs)
Mounting Assembly	Cross-steam adjustment	Stroke: 80mm (3.2 inch) electric inching method Slide speed: 12/14 cm/min. (4.7/5.5 inch/min.) (50/60 Hz)
	Vertical Head adjustment	Stroke: 350mm (13.8 inch) electric inching method Slide speed: 24/28 cm/min. (9.4/11 inch/min.) (50/60 Hz)
	Torch angle adjustment	±10° (to the level) by manual hand knob
	Dimensions and weight	570W × 300D × 700H mm, 75Kgf (22.4W × 11.8D × 27.6H inch, 165 lbs)
Wire Feed Unit	Wire feed speed	Max. 6 m/min. (19.7 ft/min.)
	Applicable wire size	2.0 × 2.0φ mm (0.079 × 0.079 inch)
	Dimensions and weight	260W × 280D × 500H mm, 10Kgf (10.2W × 11.0D × 19.7H inch, 22 lbs)
Shield Gas Box and Vertical slide	Shield gas box	Dual shielding, water cooled type
	Vertical slide	by manual hand knob
	Weight	6 Kgf (13.2 lbs)
Shield Gas Nozzle	Shield gas nozzle	Dual Shielding, water cooled type
	Weight	4 Kgf (8.8 lbs)
Torch	Applicable wire size	2.0 × 2.0φ mm (0.079 × 0.079 φ inch)
	Weight	2 Kgf (4.4 lbs)
Tip	Applicable wire size	2.0 × 2.0φ mm (0.079 × 0.079φ inch)
Wire Reel	Applicable wire weight	20 Kgf (44 lbs)
	Dimensions and weight	500φ × 240D mm 9 Kgf (19.7φ × 9.4D inch, 19.8 lbs)
Control Box	Controlling items	<ul style="list-style-type: none"> ◦ Weld start ◦ Weld stop ◦ Welding current rheostat (with meter) ◦ Welding voltage rheostat (with meter) ◦ Travel speed rheostat (with meter) ◦ Gas test ◦ Wire inching (up/down) ◦ Cross-steam adjustment inching ◦ Vertical head adjustment inching ◦ Travel (forward/backward) ◦ Travel (automatic/manual) ◦ Crater current rheostat ◦ Crater Voltage rheostat
	Dimensions and weight	310W × 220D × 520H mm, 28 Kgf (12.2W × 8.7D × 20.5H inch, 61.7 lbs)
Remote Pendant Box	Controlling item	Cross-seam adjustment inching
Cables	Control cable	Welding power supply-Control box 20 m (65.6 ft)
	Electrode cables	80 mm ² × 1 m × 2 pcs. (with cable connectors) (0.12 inch ² , × 4.3 f)
	Arc voltage detection cable	10 m (with a permanent magnet) (32.8 ft)
Sub-control Box	Controlling items	Control power source ON/OFF Control power source indication lamp
	Dimensions and weight	300W × 400D × 210H mm, 20Kgf (11.8W × 15.7D × 8.3H inch, 44 lbs)
	Note: Characteristic of D.C. welding power supply and specification of output control rheostat should be noticed in advance.	
Rail	Dimensions and weight	250W × 1,800L × 60H mm, 30 Kgf (9.8W × 70.9L × 2.4H inch, 66 lbs)

Connection Diagram

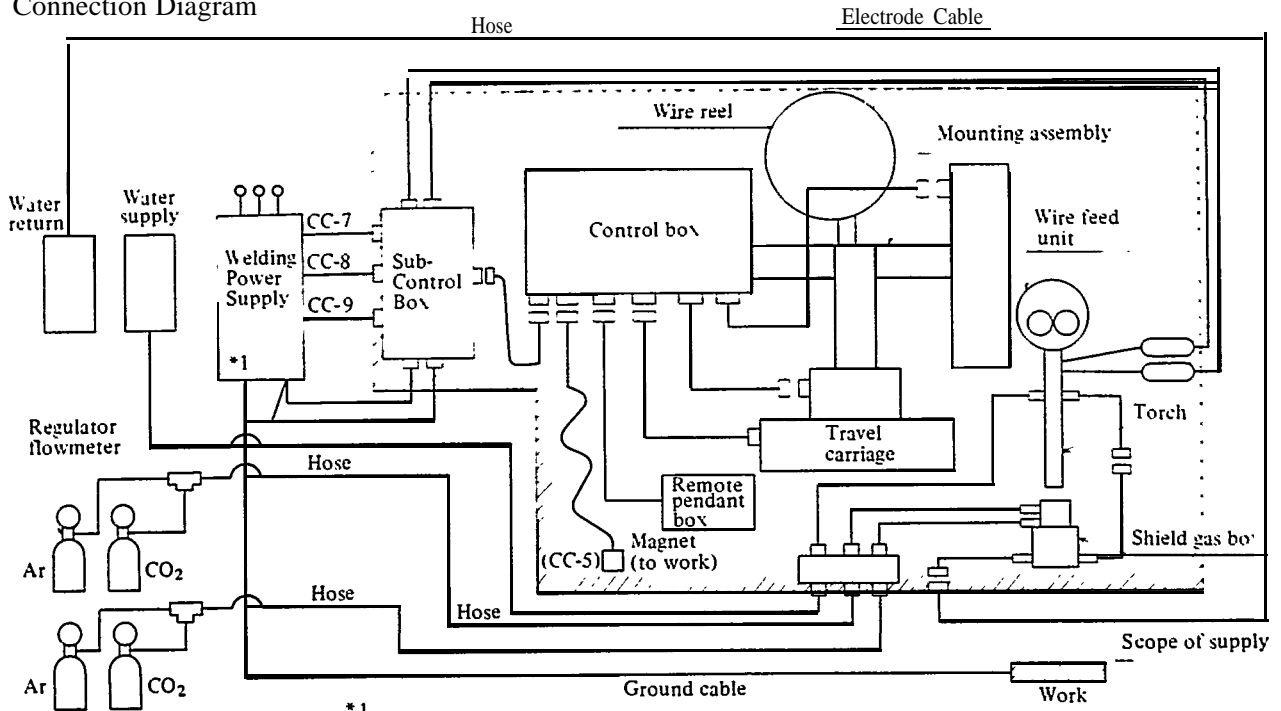

Specification	
Type	SCR output controlled three phase D.C. power SUPPLY
Characteristic	Dropping/constant voltage Characteristic should be noticed in advance.
Capability	Above 550 Amperes 34 volts 100% duty cycle

General Drawing

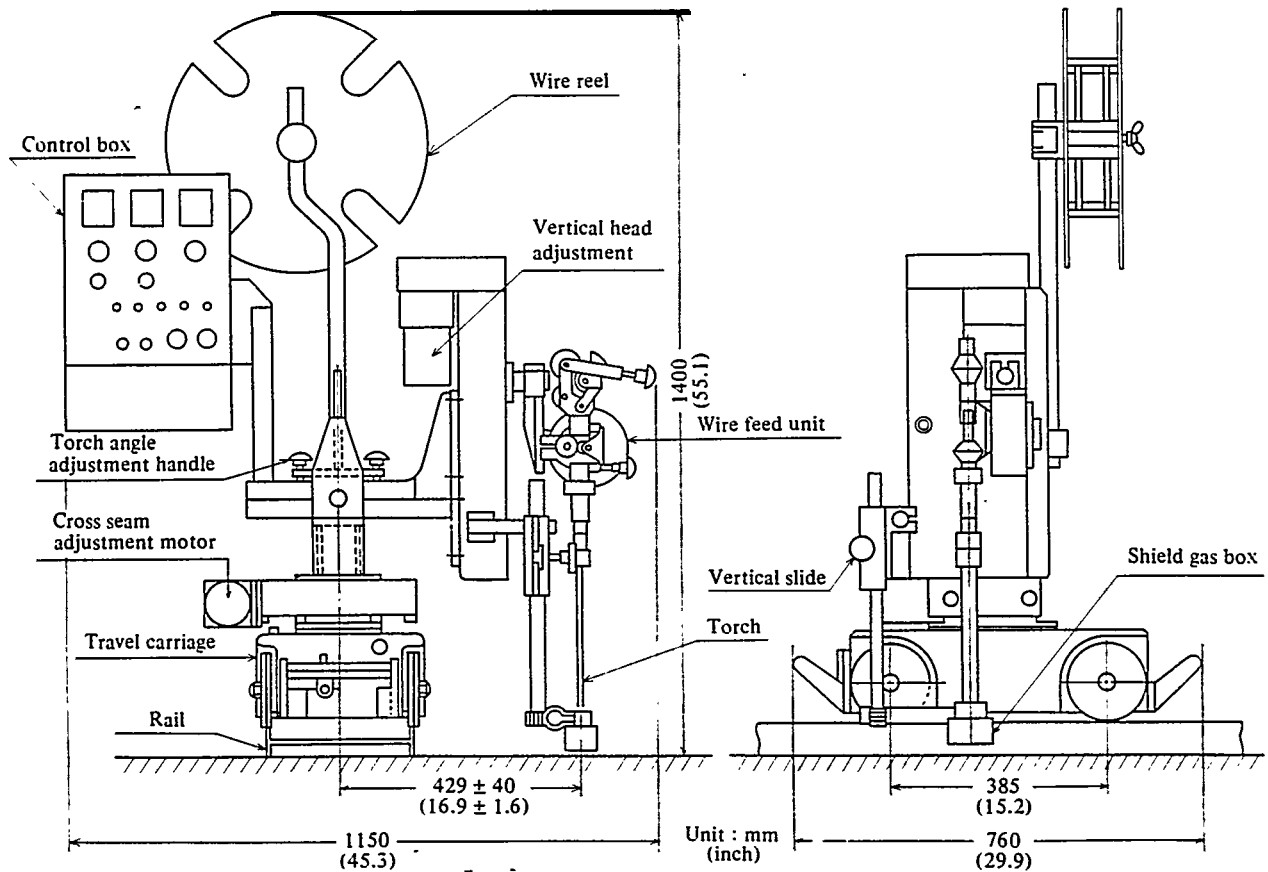

KOBELCO



KOBE STEEL, LTD.

WELDING DIVISION

Tokyo Office: Ishizuka-Yaesu Bldg., No. 5-20, Yaesu 1-chome,
Chuo-ku, Tokyo, Japan
TEL. (03) 218-7111 TELEX 222-3601 KOBSTL
Cable Address: "KOBESTEEL TOKYO"

New York Office: 529, Fifth Avenue, New York, N. Y., 10017, U.S.A.
TEL. 212-751-9400
TELEX 222341,420781

Diisseldorf Office: 10, Immermann Str. Dusseldorf, West Germany
TEL. 353891 TELEX 858-7514

Los Angeles Office: 707 Wilshire Blvd., Suite 4300,
Los Angeles, California 90017, U.S.A.
TEL. (213) 628-8480,8481 TELEX 0677392

Singapore Office: Tower 2102, 21 Floor, DBS Bldg.,
6, Shenton Way, Singapore-1.
TEL. 221-6177,6178 TELEX 23338