

**JULY 1986**

STUDY OF THE MECHANISED MANUFACTURE AND WELDING  
OF REINFORCED SHELL UNITS FROM ROLLED SHELL  
PLATE AND TEE BAR SEGMENTS

BY

ROGGENDORFF AND PARTNERS CO., LTD.  
WEST SUSSEX, ENGLAND

Done In Cooperation With:

AVONDALE INDUSTRIES, INC.  
NEW ORLEANS, LA

and

THE MARITIME ADMINISTRATION  
WASHINGTON, DC

# Report Documentation Page

Form Approved  
OMB No. 0704-0188

Public reporting burden for the collection of information is estimated to average 1 hour per response, including the time for reviewing instructions, searching existing data sources, gathering and maintaining the data needed, and completing and reviewing the collection of information. Send comments regarding this burden estimate or any other aspect of this collection of information, including suggestions for reducing this burden, to Washington Headquarters Services, Directorate for Information Operations and Reports, 1215 Jefferson Davis Highway, Suite 1204, Arlington VA 22202-4302. Respondents should be aware that notwithstanding any other provision of law, no person shall be subject to a penalty for failing to comply with a collection of information if it does not display a currently valid OMB control number.

1. REPORT DATE <b>JUL 1986</b>		2. REPORT TYPE <b>N/A</b>		3. DATES COVERED <b>-</b>	
4. TITLE AND SUBTITLE <b>Study of the Mechanised Manufacturing and Welding of Reinforced Shell Units From Rolled Shell Plate and Tee Bar Segments</b>				5a. CONTRACT NUMBER	
				5b. GRANT NUMBER	
				5c. PROGRAM ELEMENT NUMBER	
6. AUTHOR(S)				5d. PROJECT NUMBER	
				5e. TASK NUMBER	
				5f. WORK UNIT NUMBER	
7. PERFORMING ORGANIZATION NAME(S) AND ADDRESS(ES) <b>Naval Surface Warfare Center CD Code 2230 - Design Integration Tools Building 192 Room 128 9500 MacArthur Blvd Bethesda, MD 20817-5700</b>				8. PERFORMING ORGANIZATION REPORT NUMBER	
9. SPONSORING/MONITORING AGENCY NAME(S) AND ADDRESS(ES)				10. SPONSOR/MONITOR'S ACRONYM(S)	
				11. SPONSOR/MONITOR'S REPORT NUMBER(S)	
12. DISTRIBUTION/AVAILABILITY STATEMENT <b>Approved for public release, distribution unlimited</b>					
13. SUPPLEMENTARY NOTES					
14. ABSTRACT					
15. SUBJECT TERMS					
16. SECURITY CLASSIFICATION OF:			17. LIMITATION OF ABSTRACT <b>SAR</b>	18. NUMBER OF PAGES <b>73</b>	19a. NAME OF RESPONSIBLE PERSON
a. REPORT <b>unclassified</b>	b. ABSTRACT <b>unclassified</b>	c. THIS PAGE <b>unclassified</b>			

STEPHEN L. ROGGENDORFF D.Sc. - AUTHOR

C.J. WALKER, Chartered Engineer . . . . .CONTRIBUTOR  
F.I. Mech. E.

DIPL. ING. H. HONIG . . . . .CONTRIBUTOR

S. ROGGENDORFF, B.Sc . . . . .CONTRIBUTOR

MECHANISED MANUFACTURE AND WELDING OF REINFORCED UNITS (SHELL RINGS)  
U.S. Patent No : 4,371,108

Simple Stage by Stage Production with Step by Step Monitoring and Time Recording Control establishes a system eminently suitable for the accurate handling and positioning of a workpiece relative to the operation to be performed.

A balanced distribution of the workload between Stages maintains an inbuilt flexibility throughout the complete operational sequence. In other words the end product is without restraint successively built up through selective positioning with fully balanced heat in-put control throughout a Stage by Stage Production System.

Loading, unloading and transportation of components, sub-assemblies and final product is so planned as to prevent any possible damage to work already completed.

This Study attempts to describe two mechanised methods of Shell Ring manufacture; both are according to a Stage by Stage Production Method.

Alt. 1: Carried out without the use of Shop Crane for Shell Rings up to 34 ft. in diameter, 75 U.S. Tons in weight and 12 ft. in length.

Alt. 2: Carried out with the partial use of Shop Crane for Shell Rings up to 44 ft. in diameter, 100 U.S. Tons in weight and 10 ft. in length.

Ground Transportation for Alternative 1 is by Self-Propelled Carriages of single or split construction on Tracks. All vehicles are equipped with Hydro-Mechanical lifting, lowering, and support mechanism for transporting, loading or unloading operation forming an integral part of the Production Line.

It must be stressed that in order to achieve an acceptable end product, the Components, i.e. Shell Plates and Tee Bar Segments, from which such end product is made, must conform to the following requirements:-

#### SHELL PLATE SEGMENTS

- a. The long edges of the Plate that will ultimately be the circumferential edges of the Segment are to be provided with the required edge preparation to suit the welding system used to join Ring-to-Ring.
- b. After edge setting both short sides (ends) of the plate to be rolled, the flat end must be removed and provided with the required edge preparation to suit the Longitudinal Seam Welding procedure.
- c. The Plate to be rolled into Shell Segment must be correct in all respects to produce a ring to the desired 'as-built' dimension.
- d. Initial weld tests will have established any shrinkage allowances that will be required by the chosen weld procedure and this data will be used to establish the dimensions referred to in para (c) above.

TEE BAR SEGMENTS AND MAKE-UP PIECES

- a. The Tee Bar should be rolled with Toe-outwards and to a diameter that will permit the Toe to be machined to the appropriate dimension and provided with suitable weld preparation.
  
- b. The ends OF Tee Bar Segments should be provided with a weld preparation for butt-to-butt welding at a later stage.

NOTE :

In case no suitable Tee Bar rolling facility is available, use standard method in preparation of Segments by rolling Flange, flame cutting Web, welding Web to Flange and machining all edges subject to welding to correct dimensional requirement.

REINFORCED SHELL UNIT [SHELL RING]

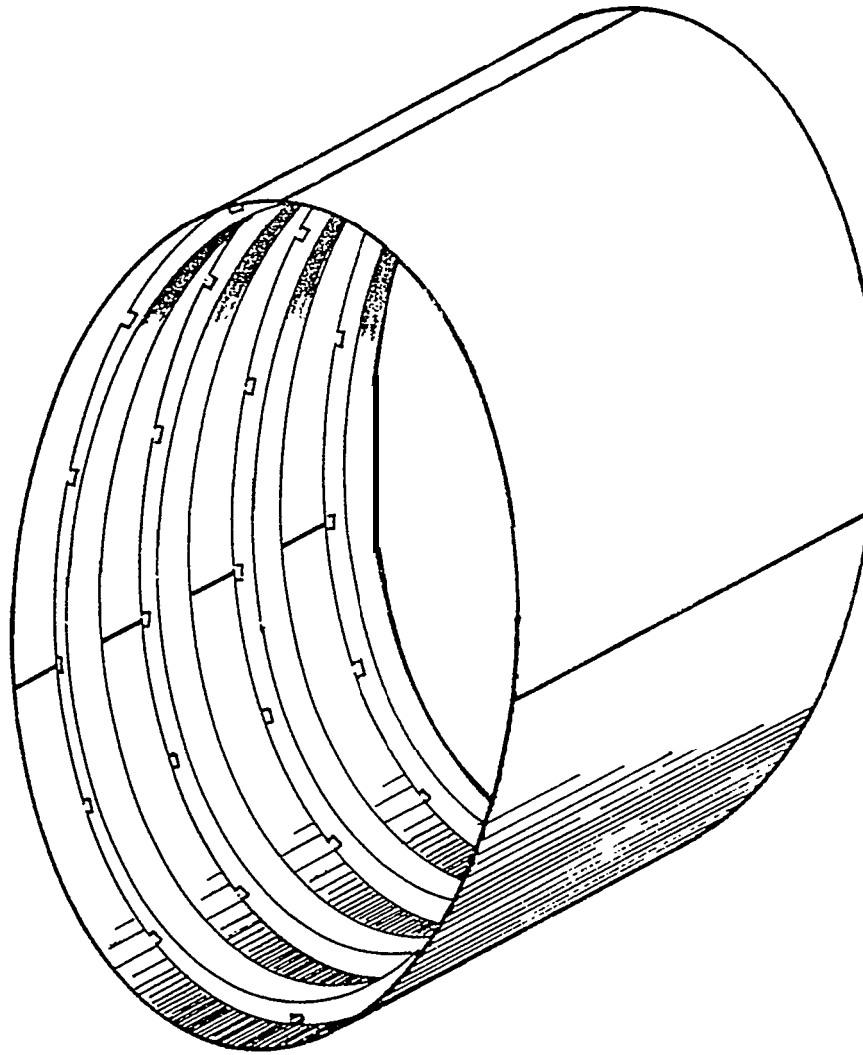

Alternative 1 : Up to 33Ft. in diameter, 75 US Tons in weight  
and 12ft. Shell Unit length

Alternative 2 : Up to 44ft. in diameter, 100 US Tons in weight  
and 10ft. Shell Unit length.

MECHANISED MANUFACTURE AND WELDING OF REINFORCED  
SHELL UNITS (SHELL RINGS)

PRODUCTION LINE : ALTERNATIVE 1

A Four stage Production Line for Shell Rings up to 34ft. in diameter,  
75 US Tons in weight and 12ft. in length, and as described hereafter.

A:	PRODUCTION EQUIPMENT - under pages	19 - 13
B:	PRODUCTION SEQUENCE - under pages	14 - 18
C:	ILLUSTRATIONS under pages	19 - 25
D:	PHOTOGRAPHS under pages	65 - 72

TECHNICAL DATA OF A MELDING METHOD FOR THE PRODUCTION OF LARGE DIAMETER REINFORCED RINGS (SHELL RINGS) (3 SHELL SEGMENTS PER SHELL RING WITH 4 TEE-SEGMENTS IN EACH)

---

All data herein is based on a maximum heat input during welding of 55,000 joules per inch. This data should be adjusted if a different heat input is required.

Further, the figures herein are based on Shell Rings 33ft. diameter x 12ft. wide and 1½ inch wall thickness with 4 Tee Bar Stiffening Rings per Shell Ring.

Tack and Welding Operations are carried out in pre-heated conditions at a temperature to the requirement of the Specification.

STAGE I M.I.G. for continuous Tack Welding Tee Bar Segments into Shell Plate-Segments (Root only)

STAGE II M.I.G. for temporary Internal Tack Welding Shell Plate Segments to Shell Plate Segments

M.I.G. for External Longitudinal Root Welding

Back Gouging of Internal Tacks if so required.

SUBMERGED ARC for Internal Long Seam  
for External Long Seam

STAGE III M.I.G. for Tack Welding Tee Bar Make-up Pieces into position.

SHIELDED METALLIC ARC (Manual) for Welding Butt-to-Butt joints on a number of Tee-Bars. The rest are completed in Stage IV.

STAGE IV SUBMERGED ARC for Circ-welding Tee Bar Stiffener Rings into Shell, both sides simultaneously where possible and 2 Rings at a time.

SHIELDED METALLIC ARC (Manual) for Welding Butt-to-Butt joints completing the rest of Tee-Bars.

ESTIMATED THROUGH-PUT HOURS AND NUMBER OF OPERATORS PER SHELL RING (3 SHELL SEGMENTS PER SHELL RING WITH 4 TEE-SEGMENTS IN EACH)

---

STAGE I	57 Hours	5 Operators
STAGE II	54 Hours	5 Operators 1 Manual Welder
STAGE III	56 Hours	4 Operators 4 Manual Welders
STAGE IV	58 Hours	5 Operator 4 Manual Welders

The above excludes X-Ray if required

Maintenance

Supervision

Connected Power for all Machinery and Transportation and Welding Power source employed in above Stage I to Stage IV inclusive - in the region of 1000 kW.

A : PRODUCTION EQUIPMENT

## STAGE I

### VERTICAL ADJUSTABLE POSITIONER ON TURNTABLE

is a sturdy, all welded steel construction of amply dimensioned sections and is designed and built to give vibration Free rotation of the face plate to which a Cradle with electro-hydraulic Clamping mechanism has been fitted to receive the shell segments. Vertical adjustment of 5ft. 6 inches is provided to cope with shell segments radii between 12ft. and 17ft. Shell segment width between 6ft. and 12ft. Total load carrying capacity 25 US Tons.

The Positioner is mounted on a Turntable which allows it to rotate through 180° providing three working positions as follows:

- 1: at 0° for loading shell segment onto Cradle
- 2 : at 90° for inserting and tacking Tee Bar segments
- 3 : at 180° for unloading shell segment completed with Tee Bar segments onto Transporter

### 814 S ASSEMBLING + TACKING MACHINE

'The Crocodile' is of hydro-mechanical design, of extra heavy, robust welded steel construction which is self-propelled on tracks. It is fitted with Grab and Clamping Mechanism to deliver and hold Tee Bar segments firmly to shell segment ready for tack welding. It can be equipped with suitable welding head or heads for single or twin tacking operation.

The Grab and Clamping Mechanism is designed to cope with Tee Bar segment radii between 12ft. and 17 ft. However, the Clamping Rollers and Grab jaws are interchangeable to suit flange dimensions.

### TEE BAR LOADER

is suitably designed to collect Tee Bar segments, one after the other, from adjacent Buffer Station and to present them to the 8145 'The Crocodile' Assembling and Tacking Machine in such a manner that the 814 Grab Mechanism can freely and safely take hold of the segment and allow the Loader to withdraw.

### TRANSPORT VEHICLE 'A' (TRANSPORTER)

of hydro-mechanical split type construction, self-propelled on two sets of tracks. Suitably designed to drive under plate segments in Buffer Zone, lift segment and deliver it into Cradle of Positioner, retract and return to Buffer Zone. Load carrying capacity 15 US Tons.

This Vehicle also carries out re-positioning of Workpieces on Buffer itself to ensure continuous supply and prevent bottle necks occurring.

## STAGE II

### VERTICAL ADJUSTABLE POSITIONER ON TURNTABLE

is a sturdy, all welded steel construction of amply dimensioned sections and is designed and built to give vibration free rotation of the face plate to which a Centralized Upright with electro-hydraulic Clamping mechanism has been fitted to receive the shell segments and assemble them into a complete Shell Ring. Vertical adjustment of 5ft. 6 inches is provided to cope with shell segments radii between 12ft. and 17 ft. Shell segment width between 6ft. and 12ft. Total load carrying capacity 75 US Tons. In addition to the above described function, the Positioner is also suitably constructed to carry out External Longitudinal Seam Welding operation in accordance to Specification.

The Positioner is mounted on a Turntable which allows it to rotate through 180° providing three working positions as follows:

- I : at 0° for loading Shell Ring Segments
- 2 : at 90° for Tacking and Long Seam Welding
- 3 : at 180° for unloading Shell Ring into Transport Carriage

### 814 S ASSEMBLING + TACKING MACHINE

'The Crocodile' is of hydro-mechanical design, of extra heavy, robust welded steel construction which is self-propelled on tracks. It is equipped with hydro-mechanical sub-presses suitably constructed to align plate edges of Shell Segments prior to tacking. Following Tacking and External Longitudinal Seam Welding operation, this machine will carry out the following additional work:

- a : Back Gouging
- b : Internal Longitudinal Seam Welding
- c : Remove weld reinforcement

### TRANSPORT VEHICLE 'B' (TRANSPORTER)

of hydro-mechanical construction, self-propelled on track. Suitably designed to drive under Shell Ring Segment in Buffer Zone, lift, deliver and radially position same under Clamping Mechanism of Positioner. Following clamping, Carriage retracts and returns to Buffer Zone. Load carrying capacity 25 US Tens.

This Vehicle also carries out re-positioning of Workpieces on Buffer itself to ensure continuous supply and prevent bottle necks occurring.

## STAGE III

### VERTICAL ADJUSTABLE POSITIONER ON TURNTABLE

is a sturdy, all welded steel construction of amply dimensioned sections and is designed and built to give vibration free rotation of the Face plate to which an external hydro-mechanical clamping mechanism has been Fitted to receive and clamp complete Shell Ring for fitting and tacking of Tee Bar Segment Make-up pieces. Vertical adjustment of 5Ft. 6 inches is provided to cope with shell diameters between 24t. and 34ft. at a width of between 6ft. and 12ft. Total load carrying capacity 75 US Tons.

The Positioner is mounted on a Turntable which allows it to rotate through 180° providing three working positions as follows:

- 1: at 0° for loading complete Shell Ring
- 2 : at 90° for inserting and tacking Make-up pieces
- 3 : at 180° for unloading fitted Shell Ring

### 814 S ASSEMBLING + TACKING MACHINE

'The Crocodile' is of hydro-mechanical design, of extra heavy, robust welded steel construction which is self-propelled on tracks. It is fitted with Grab and Clamping Mechanism to deliver and hold Tee Bar segments Make-up pieces firmly to shell ready for tack welding. It can be equipped with suitable welding head or heads for single or twin tacking operation

The Grab and Clamping Mechanism is designed to cope with Tee Bar segment Make-up piece radii between 12ft. and 17ft. However, the Clamping Rollers and Grab Jaws are interchangeable to suit flange dimensions.

### TRANSPORT VEHICLE 'C' (TRANSPORTER)

of hydro-mechanical construction, self-propelled on track. Suitably designed to drive under Shell Ring in Buffer Zone, lift and deliver same into External Clamping Mechanism of Positioner. Following clamping, Carriage retracts and returns to Buffer Zone. Load Carrying capacity 75 US Tons.

This Vehicle also carries out re-positioning of Workpieces on Buffer itself to ensure continuous supply and prevent bottle necks occurring.

## S T A G E    I V

VERTICAL ADJUSTABLE POSITIONER ON TURNTABLE

This Positioner is identical in construction and dimensions to that described in STAGE III, and is designed for the following operations.

- I:    at    0° for loading complete Shell Ring
- 2 : at 90° for circumferential welding  
          operation of Tee Bar into Shell
- 3 : at 180° for unloading complete Shell Ring

INTERNAL CIRC-WELDING MANIPULATOR

Suitably designed to move into and out of Shell Ring Assembly and carry out Internal Circ-welding operation of Tee Bar Webs into Shell.

It is equipped with Twin Welding Heads for the simultaneous welding operation on both sides of a Tee Bar Web to the Shell. This can be duplicated to carry out welding operation jointly on two Tee Bar segments.

The Manipulator can be equipped with an Auxilliary Back Gouging Mechanism if required by the specification according to which the work is carried out.

TRANSPORT VEHICLE 'D' (TRANSPORTER)

of Hydro-mechanical construction, self propelled on track. Suitably designed to drive under Shell ring in Buffer Zone, lift and deliver same into External Clamping mechanism of Positioner. Following clamping, Carriage retracts and returns to Buffer Zone. Load carrying capacity 75 US Tons.

This Vehicle also carries out re-positioning of Workpieces on Buffer itself to ensure continuous supply and prevent bottle necks occuring.

TRANSPORT VEHICLE 'E' (TRANSPORTER)

as described above, but for unloading complete Shell Ring and deliver same onto Buffer.

This Vehicle also carries out re-positioning of Workpieces on Buffer itself to ensure continuous supply and prevent bottle necks occuring.

B : PRODUCTION SEQUENCE

## STAGE I

WORK PERFORMED

Assembling and Tack Welding Tee Bar Segments into Shell Plate Segments.

PRODUCTION SEQUENCE

- a. Vertical Adjustable Positioner on Turntable
- b. 814 S Assembling plus Tacking Machine
- c. Tee Bar Loader
- d. Transport Vehicle 'A' (Transporter)

PRODUCTION SEQUENCE

- Position : 1.1      Buffer for Shell Segments for Rolling Station
- Position : 1.2      First Shell Segment collected and loaded by Transport Vehicle 'A' onto Cradle of Rotary Positioner at 0° angle.
- Position : 1.3      Assembling Machine Type: 814 s 'The Crocodile' receives from Loader, delivers, inserts, clamps and tack welds Tee Bar Segments into Shell Segments when Cradle on Positioner is at 90° angle.
- Position : 1.4      Loader to transfer Tee Bar Segment from Rack onto Grab Mechanism of 'The Crocodile'.
- Position : 1.5      Tee Bar Rack with Pre-heating Facility.
- Position : 1.6      On completion of above, Positioner turns to 180° angle for unloading Shell Ring Segment from Cradle onto Transport Vehicle 'B'.

## STAGE II

### WORK PERFORMED

Assembling, Aligning and Longitudinal Seam Welding Shell Ring Segments produced in STAGE 1.

### PRODUCTION EQUIPMENT

- a. Vertical Adjustable Positioner on Turntable.
- b. 814 S Assembling plus Tacking Machine
- c. Transport Vehicle 'B' (Transporter)

### PRODUCTION SEQUENCE

- |                |   |
|----------------|---|
| Position : 2.1 | Buffer Zone for Shell Ring Segments from Stage I, collected by Transport Vehicle 'B'  |
| Position : 2.2 | First Shell Ring Segment collected by Transport Vehicle 'B' and transferred into electro-hydraulic Clamping Mechanism fitted to Face Plate OF Positioner when at 0° angle. Rotate Face Plate suitably to receive second and subsequent third Shell Ring Segment to form a complete clamping Shell Ring. |
| Position : 2.3 | Assembling Machine Type: 814 S 'The Crocodile' with hydro-mechanical Sub Presses, aligns and tacks Shell Segment to Shell Segment when Positioner at 90° angle.   |
| Position : 2.4 | External Longitudinal Seam Welding Operation, performed by Manipulator part of Positioner when Cradle is at 90° angle.  |
| Position : 2.5 | 'The Crocodile' to Back Gouge, complete Internal Longitudinal Seam and remove Weld Reinforcement, if required.  |
| Position : 2.6 | On completion of above, Positioner Turns to 180° angle for unloading Shell Ring Assembly from Positioner to Transport Vehicle 'C'.  |

## STAGE III

### WORK PERFORMED

Assembling and Tack Welding Tee Bar Make-up Pieces into Shell Ring.

### PRODUCTION EQUIPMENT

- a. Vertical Adjustable Positioner on Turntable.
- b. 814 S Assembling plus Tacking Machine
- c. Transport Vehicle 'C' (Transporter)

### PRODUCTION SEQUENCE

- |                |   |
|----------------|---|
| Position : 3.1 | Buffer Shell Ring Assembly from Stage II collected by Transport Vehicle 'C'   |
| Position : 3.2 | Shell Ring Assembly collected by Transport Vehicle 'C' and transferred into External Hydro-mechanical Clamping Mechanism when at 0° angle.  |
| Position : 3.3 | Assembling Machine Type: 814 S 'The Crocodile' receives from Loader, delivers, inserts, clamps and tack welds Tee Bar Segment Make-up Pieces into Shell Rings on Positioner at 90° angle. |
| Position : 3.4 | Loader to transfer Tee Bar Segment Make-up Pieces from Rack onto Grab Mechanism of 'The Crocodile'.   |
| Position : 3.5 | Tee Bar Rack  |
| Position : 3.6 | On completion of above, Positioner turns to 180° angle for unloading Shell Ring from Positioner onto Transport Vehicle 'D'.   |

## STAGE IV

### WORK PERFORMED

Circ-welding operation Reinforcing Rings into Shell.

### PRODUCTION EQUIPMENT

- a. Vertical Adjustable Positioner on Turntable
- b. Internal Circ-Welding Manipulator
- c. Transport Vehicle 'D' (Transporter)
- d. Transport Vehicle 'E' (Transporter)

### PRODUCTION SEQUENCE

- Position : 4.1 Buffer for Shell Ring from Stage III collected by Transport Vehicle 'D'
- Position : 4.2 Shell Ring Collected by Transport Vehicle 'D' and transferred into External Hydro-mechanical Clamping Mechanism on Face Plate of Positioner at 0° angle.
- Position : 4.3 Internal Circ-welding Manipulator, with Multiple Welding Heads to carry out Tee Bar Web welding simultaneously for one or two Tee Bar Rings (2 or 4 Heads) when Positioner at 90° angle.
- An Auxilliary Back Gouging mechanism can be incorporated if welding specification so requires.
- Position : 4.4 On completion of above, Positioner turns to 180° angle for unloading completed Shell Ring onto Transport Vehicle 'E'

C : ILLUSTRATIONS

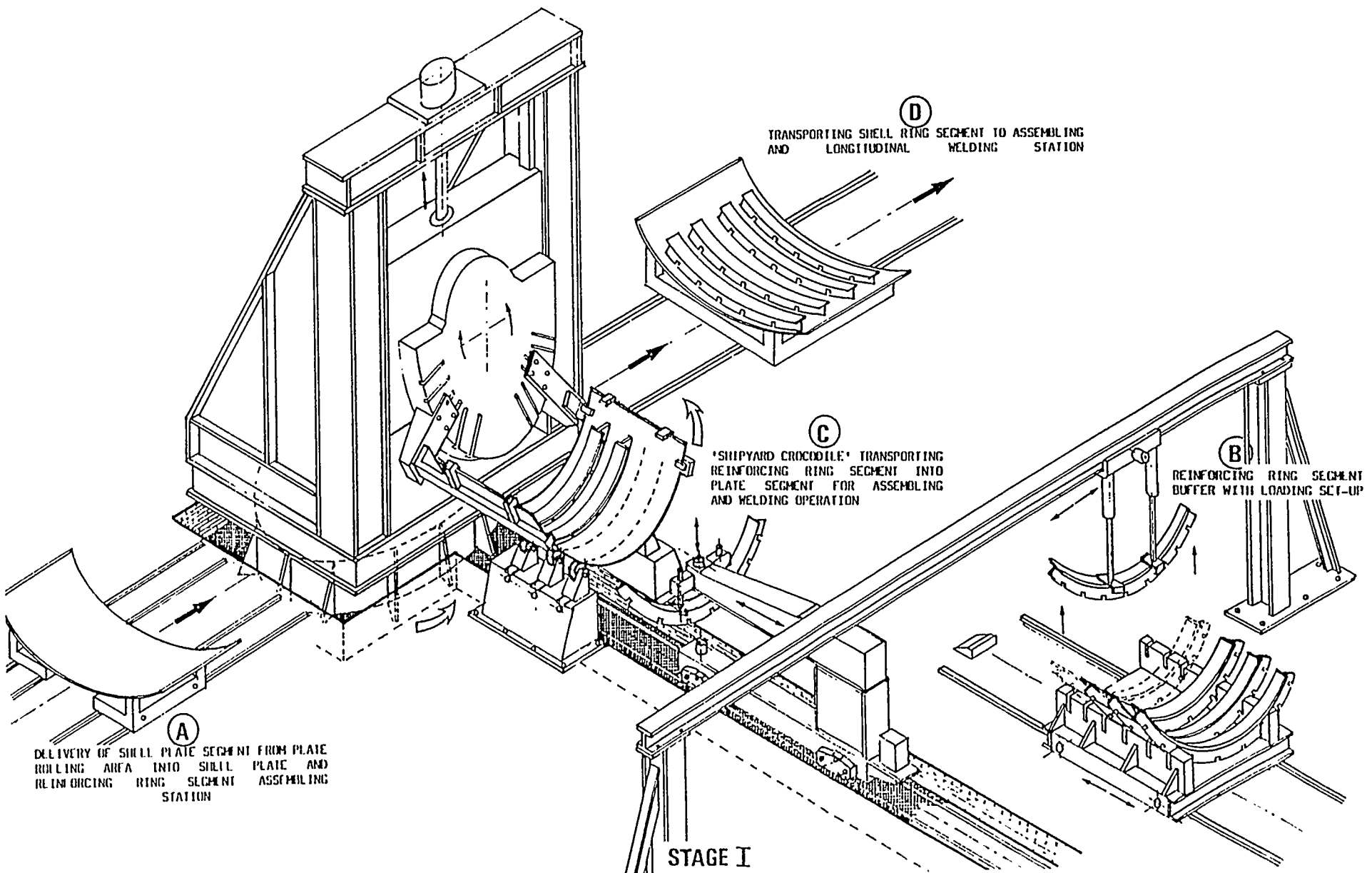

(A) DELIVERY OF SHELL PLATE SEGMENT FROM PLATE ROLLING AREA INTO SHELL PLATE AND REINFORCING RING SEGMENT ASSEMBLING STATION

(C) \*SHIPYARD CROCODILE\* TRANSPORTING REINFORCING RING SEGMENT INTO PLATE SEGMENT FOR ASSEMBLING AND WELDING OPERATION

(D) TRANSPORTING SHELL RING SEGMENT TO ASSEMBLING AND LONGITUDINAL WELDING STATION

(B) REINFORCING RING SEGMENT BUFFER WITH LOADING SET-UP

STAGE I

ASSEMBLING AND WELDING THE BAR SEGMENTS INTO SHELL PLATE SEGMENTS

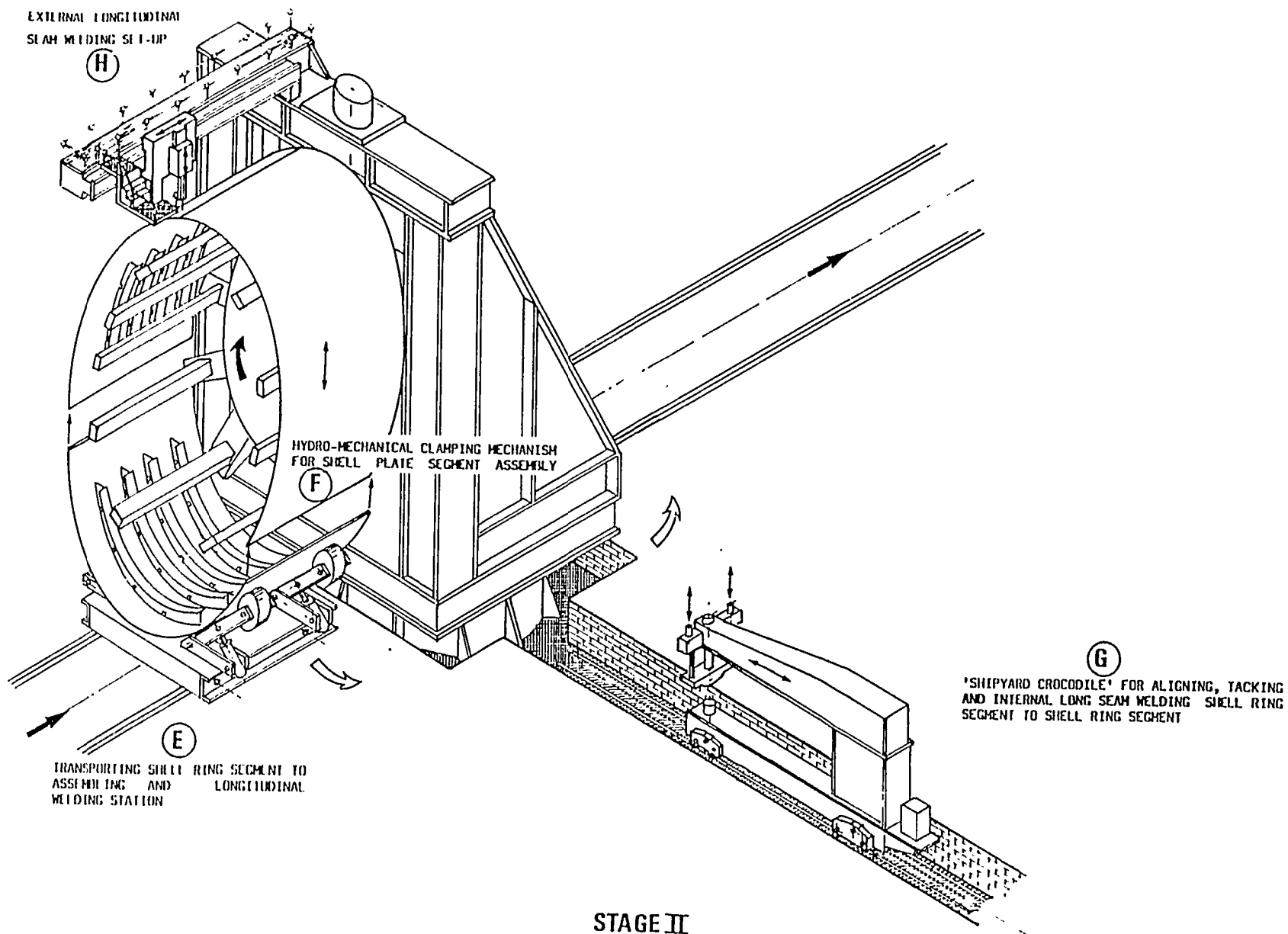

STAGE II  
 ASSEMBLING AND WELDING OF REINFORCED SHELL SEGMENTS TO SHELL RINGS - 1

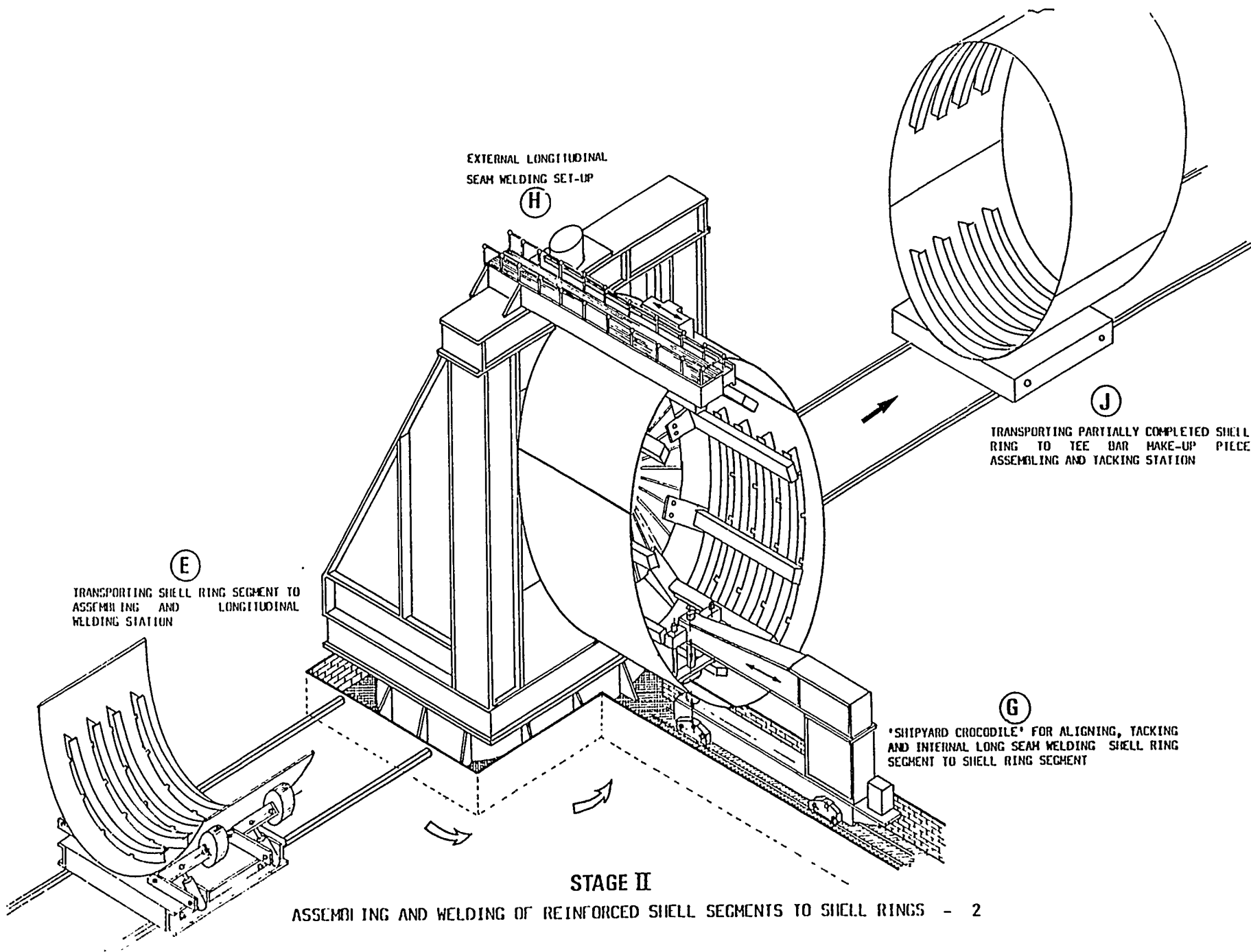

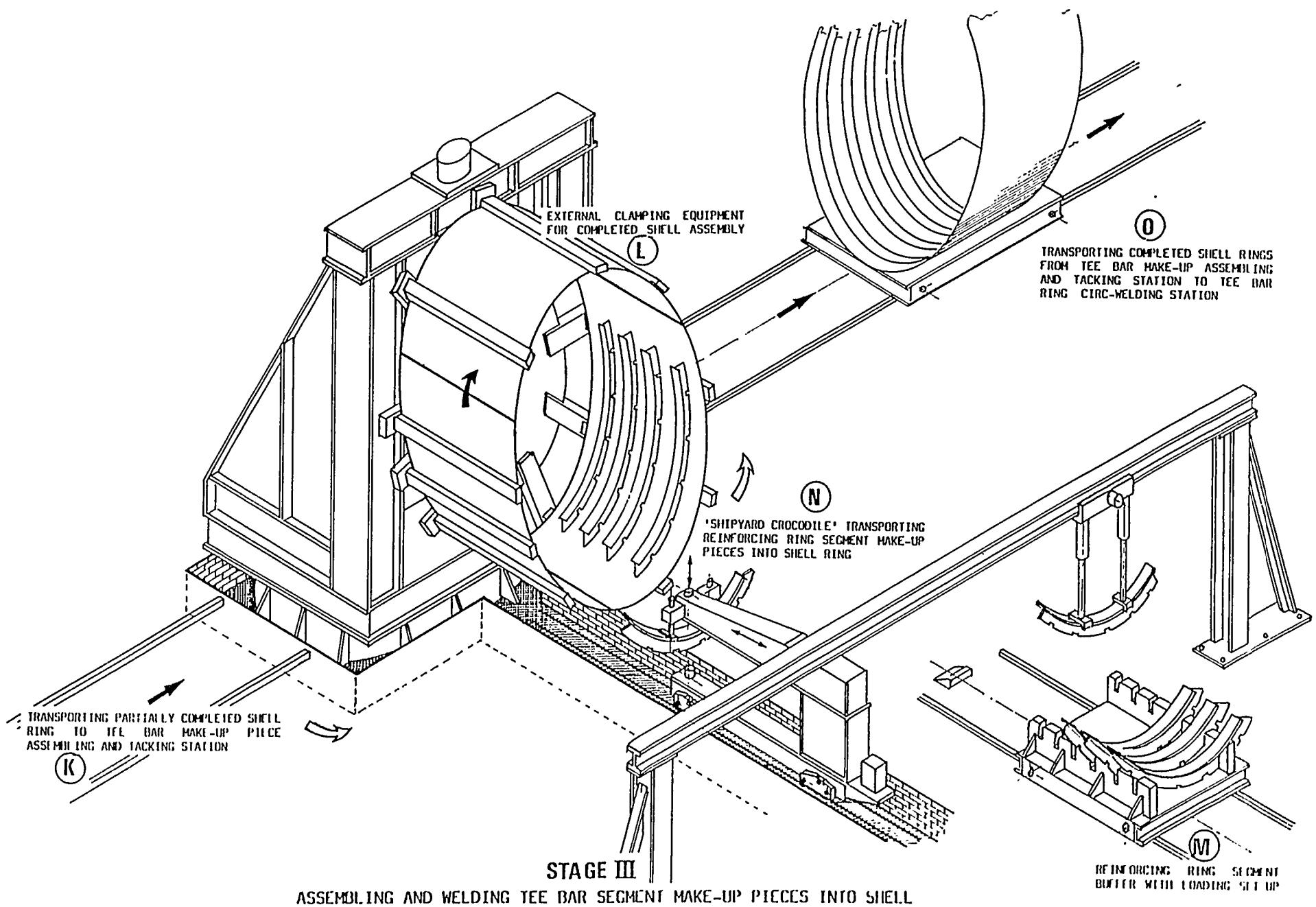

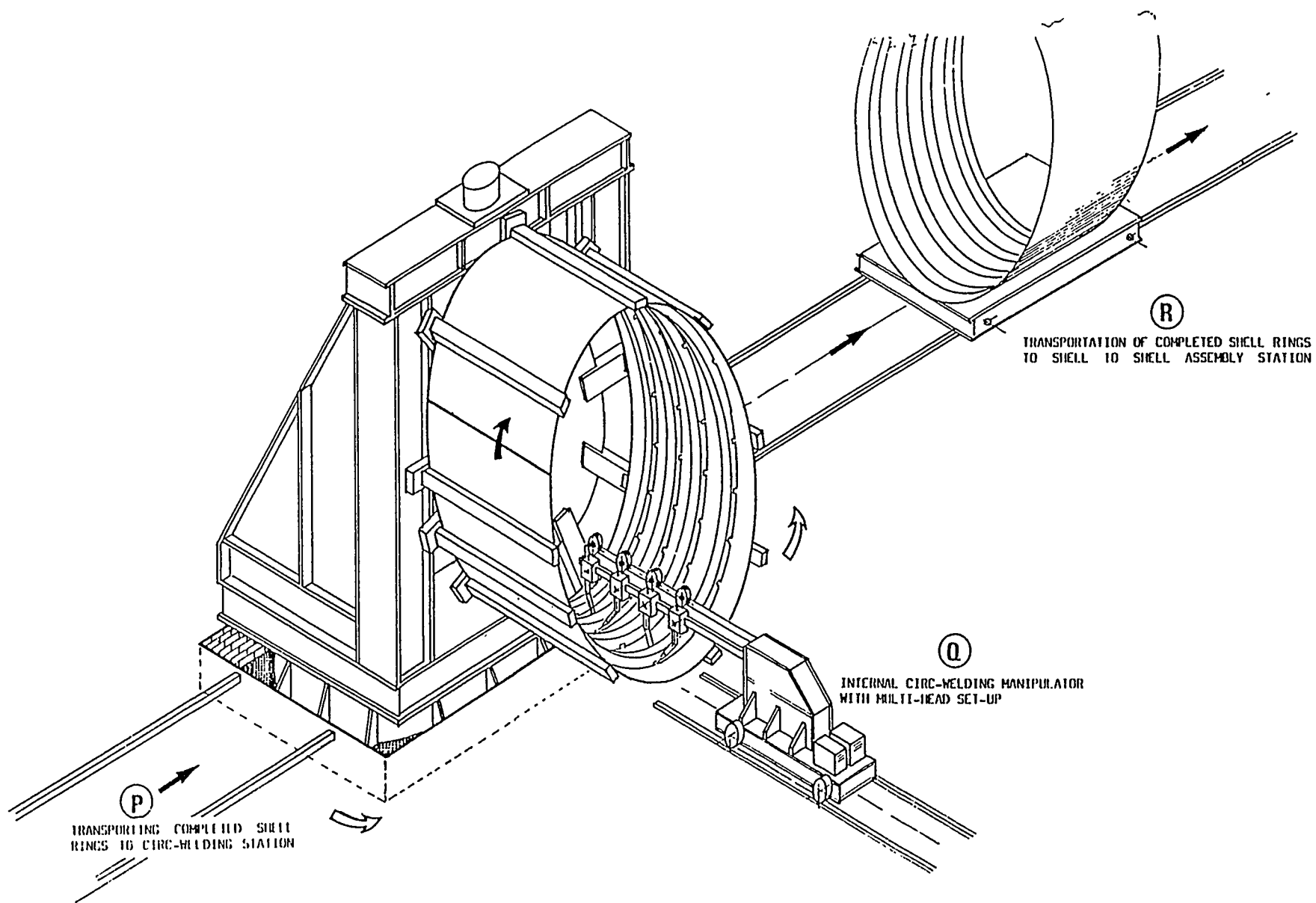

**STAGE IV**  
CIRC-WELDING TEE BAR RINGS INTO SHELLS

**MECHANISED MANUFACTURE & WELDING OF REINFORCED UNITS. (SHELL RINGS) ----- ALTERNATIVE-1**  
 U.S. PATENT No 4,371,108.

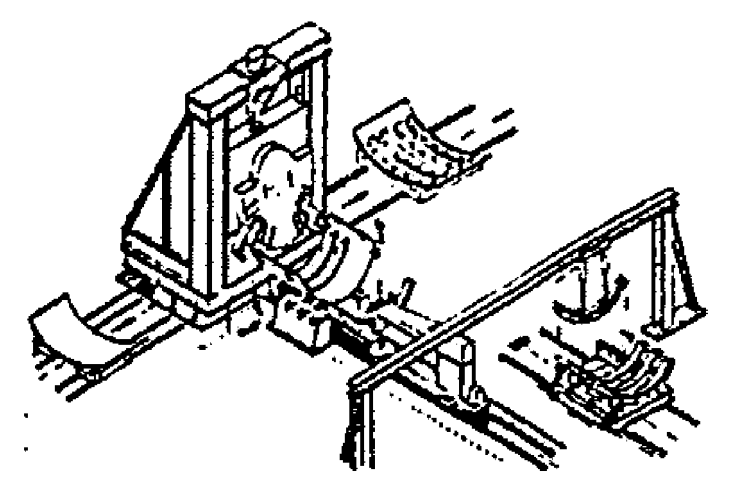
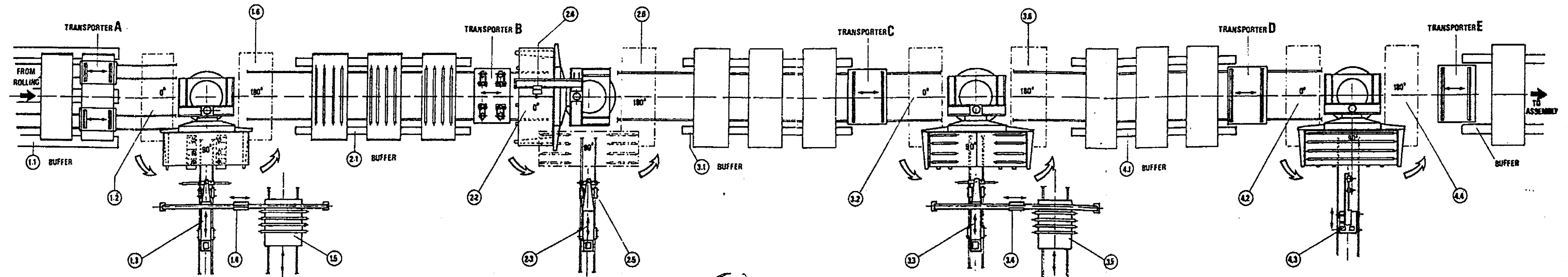

STAGE I

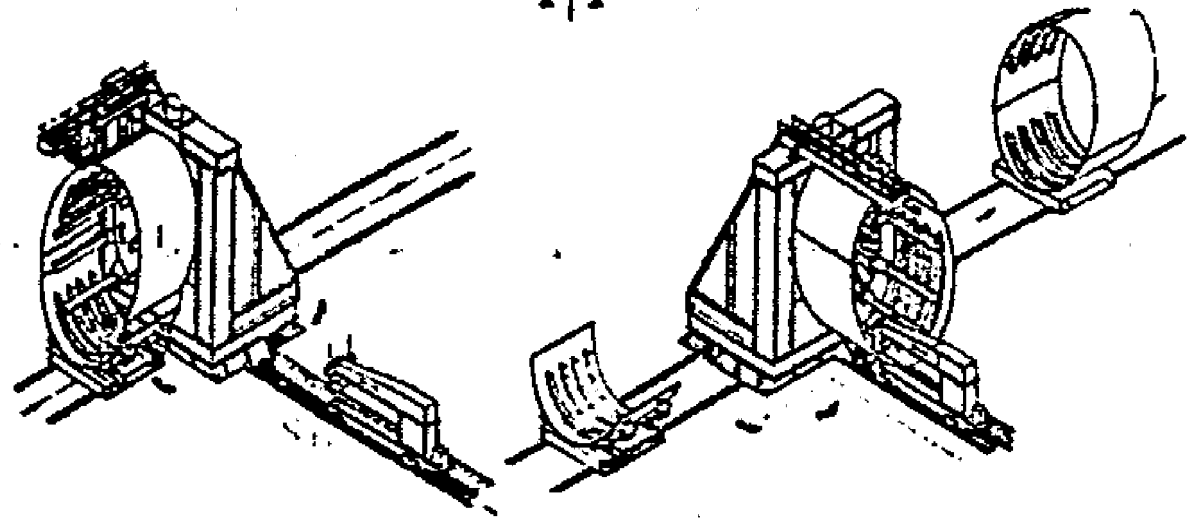

STAGE II

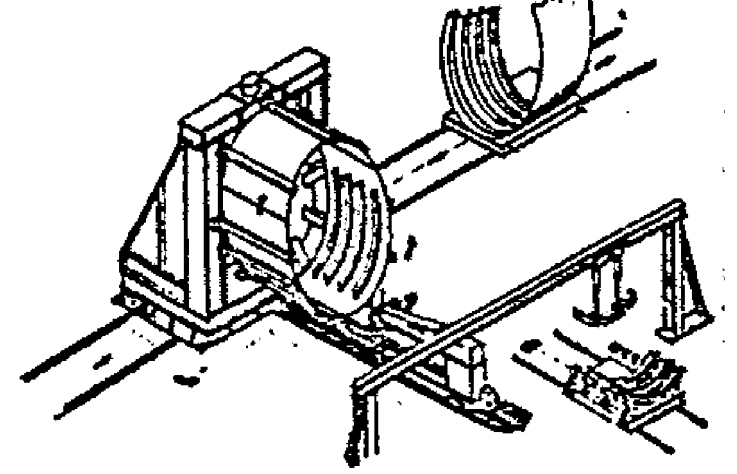

STAGE III

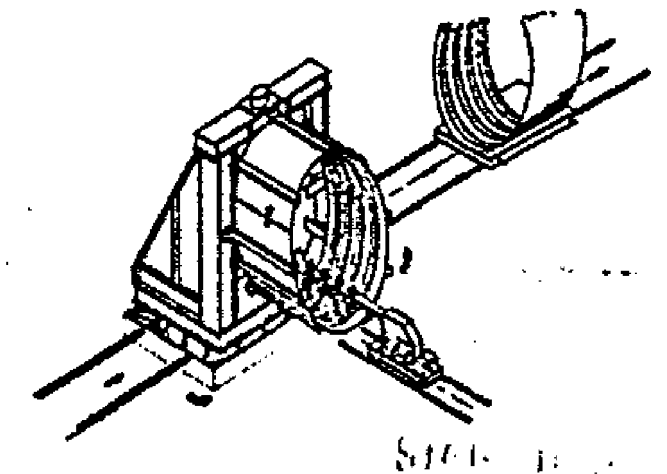

STAGE IV

MECHANISED MANUFACTURE AND MELDING OF REINFORCED  
SHELL UNITS (SHELL RINGS)

PRODUCTION LINE : ALTERNATIVE 2

A Four stage Production Line for Shell Rings up to 44ft. in diameter,  
100 US Tons in weight and 10ft. in length, and as described hereafter.

A:	PRODUCTION EQUIPMENT	- under pages	29 - 35
B:	PRODUCTION SEQUENCE	- under pages	36 - 41
C:	ILLUSTRATIONS	under pages	42 - 64
D:	PHOTOGRAPHS	- under pages	65 - 72

TECHNICAL DATA OF A WELDING METHOD FOR THE PRODUCTION OF LARGE DIAMETER REINFORCED RINGS (SHELL RINGS) (4 SHELL SEGMENTS PER SHELL RING WITH 4 TEE-SEGMENTS IN EACH)

---

All data herein is based on a maximum heat input during welding of 55,000 joules per inch. This data should be adjusted if a different heat input is required.

Further, the figures herein are based on Shell Rings 44ft. diameter x 10ft. wide and 1½ inches thick with 4 Tee Bar Stiffening Rings.

Tack and Welding Operations are carried out in pre-heated conditions at a temperature to the requirement of the Specification.

STAGE I            M.I.G. for continuous Tack Welding Tee Bar Segments into Shell Plate Segments (Root only)

STAGE II           M.I.G. for Tack Welding Shell Plate Segments to Shell Plate Segments.

PULSE ARC upwards for Internal Longitudinal Welding of Shell Plate Seam

followed by Back Gouging External Tack Welds if so required.

External and Internal Welding Simultaneously of Shell Plate Seams

STAGE IIIA        M.I.G. for Tack Welding Tee Bar Make-up Pieces into position.

SHIELDED METALLIC ARC (Manual) for Welding Butt-to-Butt joints in Tee Bars on one side only.

STAGE IIIB        SHIELDED METALLIC ARC (Manual) for finishing Welds of the Tee Bar Butt Joints on the second side.

STAGE IIIC        SUBMERGED ARC for Circ-welding Tee Bar Stiffener Rings into Shell, both sides simultaneously where possible and 2 Rings at a time.

ESTIMATED THROUGH-PUT HOURS AND NUMBER OF OPERATORS PER SHELL RING (4 SHELL SEGMENTS PER SHELL RING WITH 4 TEE-SEGMENTS IN EACH)

---

STAGE I	60 Hours	5 Operators
STAGE II	64 Hours	5 Operators
STAGE IIIA	66 Hours	5 Operators 8 Manual Welders
STAGE IIIB	48 Hours	2 Operators 8 Manual Welders
STAGE IIIC	68 Hours	4 Operators

The above excludes Crane Operators  
 Slings  
 Maintenance Work  
 Supervision  
 X-Ray if required

Connected Power for all Machinery and Transportation and Welding Power source employed in above Stage I to Stage IIIC inclusive - in the region of 900 kW.

A : PRODUCTION EQUIPMENT

## STAGE I

### VERTICAL ADJUSTABLE POSITIONER ON TURNTABLE

is a sturdy, all welded steel construction of amply dimensioned sections and is designed and built to give vibration free rotation of the face plate to which a Cradle with electro-hydraulic Clamping mechanism has been fitted to receive the shell segments. Vertical adjustment of 7ft. 6 inches is provided to cope with shell segments radii between 15ft. and 22ft. Shell segment width between 7ft. and 10 ft. Total load carrying capacity 25 US Tons.

The Positioner is mounted on a Turntable which allows it to rotate through 180° providing three working positions as follows:

- 1: at 0° for loading shell segments
- 2 : at 90° for inserting and tacking Tee Bar segments
- 3 : at 180° for unloading shell segments completed with Tee Bar segments.

### 814 S ASSEMBLING + TACKING MACHINE

'The Crocodile' is of hydro-mechanical design, OF extra heavy, robust welded steel construction which is self-propelled on tracks. It is fitted with Grab and Clamping Mechanism to deliver and hold Tee Bar segments firmly to shell ready for tack welding. It can be equipped with suitable welding head or heads for single or twin tacking operation.

The Grab and Clamping Mechanism is designed to cope with Tee Bar segment radii between 15ft. and 22 ft. However, the Clamping Rollers and Grab Jaws are interchangeable to suit flange dimensions.

### TEE BAR LOADER

is suitably designed to collect Tee Bar segments, one after the other, from adjacent Buffer Station and to present them to the 814S 'The Crocodile' Assembling and Tacking Machine in such a manner that the 814 Grab Mechanism can freely and safely take hold of the segment and allow the Loader to withdraw.

### TRANSPORT VEHICLE 'A' (TRANSPORTER)

of hydro-mechanical construction, self-propelled on track. Suitably designed to drive under plate segments in Buffer Zone, lift segment and deliver it into Cradle of Positioner, retract and return to Buffer Zone. Load carrying capacity 15 US Tons.

## STAGE II

### VERTICAL ASSEMBLING CAROUSEL

is a sturdy, welded steel construction capable of accommodating segments between 60° and 720° depending on shell diameter. (If it is essential to cover 30° - 180° this can be accommodated, but it should be considered that 180° segments will pose substantial handling and safety problems).

A heavy central upright of tubular construction forms an integral part of the face-plate OF a Turntable which itself is the base construction of the Carousel. The Turntable is fitted with extension arms on which the shell segments are positioned. The upright is suitably machined to take bolster plates equipped with two rows of hydro-mechanically actuated radially arranged clamping arms. These arms are interchangeable according to shell diameter and number of segments to be assembled.

Once the arms have clamped securely onto the Tee Bars they pull the shell segments against Multiple stop Mechanism into butt-to-butt situation for final alignment by the Edge Aligning Device, ready for tacking and longseam welding.

The Equipment is designed to cope with shells between 30 - 44 ft. in diameter and 7 - 10ft., in height (width) with a total assembled weight of not more than 100 US Tons.

### SELF-PROPELLED TILTABLE TRANSPORT VEHICLE 'B'

a robust welded steel construction, consisting of a chassis on wheels and a Platform carrying Clamping Equipment. This Platform can be elevated and pivoted through 90° about its leading edge.

The Vehicle travels underneath the nearest plate segment on Buffer, the Platform is raised so that the segment can be securely clamped and then lifted off the Buffer Rails. When Vehicle approaches Assembling Carousel its leading edge engages with fixed stops on track. Shop Crane hooks into rear edge of Platform and tilts it to vertical position, with segment still securely clamped. At this point the outer parts of the segment come to rest on the Support Carriages. These are suitably designed to allow longitudinal, lateral and vertical adjustment of the segment before it is placed on the Assembling Carousel.

Load carrying capacity of Transport Vehicle 'B' is 25 US Tons.

STAGE II  
(continued)

EXTERNAL LONGSEAM WELDER

consists of a sturdy Upright on Motorised Carriage carrying a horizontal Boom with vertical infinitely variable speed stroke. The Boom is equipped for suitable Staging for the Operator to have full control over welding.

The time in this Stage will also allow for the full or partial INTERNAL LONGSEAM WELDING operation if heat in-put balance is required and the facility for same is given therein, in which case, Stage III A will be freed partially or fully from internal longseam welding and the time gained can be used for Tee Bar Stiffener segment flange welding operation (butt-to-butt).

## STAGE IIIA & B

### TILTABLE ROTARY POSITIONER

is of welded steel construction with amply designed sections. It consists of two uprights fitted with Twin Guide tracks in which the slides of a cross-beam travel up and down. A Turntable with infinitely variable speed drive and adjustable power mechanism for external clamping of shells, is mounted on the cross-beam. The Turntable rotates and tilts through 360° to allow the workpiece to be positioned as required. The Turntable has a vertical stroke of 20ft. and a load carrying capacity of 120 US Tons at a centre of gravity of 8ft. from face-plate.

Shell having been loaded with Turntable in horizontal face-up position, it is tilted through 90° anticlockwise for internal longseams to be welded and Tee Bar make-up segments to be inserted and tacked. For partial manual welding of Tee Bar web butt joints it is returned to horizontal position, then tilted through 180° into horizontal facedown position for loading onto Transport Vehicle 'C'. This way the other side of Tee Bar web butt joints are now upwards facing and together with the Tee Bar flange edges, can be manually welded in Buffer Zone.

For Internal longseam welding - see remarks in Stage II.

### THE 814 SA ASSEMBLING + TACKING MACHINE (As illustrated Under Stage I)

'The Crocodile' of hydro-mechanical design, is an extra heavy, robust, welded steel construction which is self-propelled on track. It is fitted with Grab and Clamping Mechanism to deliver and hold Tee Bar make-up segment firmly to shell in-between Tee Bar segments already tack welded on Stage I. It can be equipped with suitable Welding Head or Heads for single or twin tacking operation, or use manual Tack Welding.

The Grab Clamping Mechanism is designed to cope with Tee Bar segment with radii of between 15ft. and 22ft., however, the Clamping Rollers and Grab Jaws are interchangeable to suit flange dimensions.

Height adjustment in the region of 7ft. is provided to compensate for radial difference of shell.

STAGE IIIA & B  
(continued)

TEE BAR LOADER (As illustrated under Stage I)

is suitably designed to collect Tee Bar make-up segments, one after the other, from adjacent Buffer Station and to present them to the 814 SA 'The Crocodile' Assembling and Tacking Machine in such a manner that the 814 Grab Mechanism can freely and safely take hold of the segment and allow the Loader to withdraw.

TRANSPORT VEHICLE 'C' (Positioned under 9.3)

of hydro-mechanical construction, self-propelled on track. Suitably designed to drive underneath Positioner, collect shell and deposit it in Buffer Zone. Load carrying capacity 80 US Tons.

BUFFER ZONE WITH STAGING (Illustrated under Stage IIIB Position 9.4)

For Manual Welding Tee Bar make-up pieces (one side only)

## STAGE IIIC

### TILTABLE ROTARY POSITIONER (No. 2)

is identical to the one described in Stage III A.

### INTERNAL CIRCWELDING MACHINE (Standard Equipment)

consists of a sturdy upright on Motorised Carriage, carrying a horizontal Boom with height adjustment. The Boom is equipped with suitable staging for two operators having full control over two pairs of Welding Heads.

### SIDE TRANSFER BRIDGE

To allow the withdrawal of Longitudinal Seam Welding machine when Transporter 'C' moves into loading position (free passage)

### TRANSPORT VEHICLE 'D'

of hydro-mechanical construction self-propelled on track. Suitably designed with necessary height adjustment to unload shell from Positioner and deposit it in Buffer Zone.

B : PRODUCTION SEQUENCE

## STAGE I

### WORK PERFORMED

Assembling and Tack Welding Tee Bar Segments into Shell plate Segment.

### PRODUCTION EQUIPMENT

- a. Vertically adjustable Rotary Positioner on Turntable.
- b. Shipyard Crocodile with Transport Grab and frictionless Clamping Mechanism.
- c. Tee Bar Loader (from Tee Bar Rack to Shipyard Crocodile)
- d. Transport Vehicles (A) & (B).

### SEQUENCE

- |                |   |
|----------------|---|
| Position : 1.1 | Buffer Zone for Shell Segments from Rolling Station, for . . .  |
| Position : 1.2 | Shell Segment No. 1 loaded by Transport Vehicle A onto Rotary Positioner. At the same time. . .   |
| Position : 1.3 | Assembling Machine Type: 814 S 'The Crocodile' takes Segment from Tee Bar Loader operating between Tee Bar Rack and the Crocodile. Simultaneously . . . |
| Position : 1.4 | turn Positioner clockwise through 90° for the loading of Tee Bar Segment into Shell Segment using . . .   |
| Position : 1.5 | the Crocodile to Insert, Clamp and Tack Weld Tee Bar Segment into Shell Segment. On completion of loading all required Tee Bars Segments . . .          |
| Position : 2.1 | turn Positioner clockwise through 90° for . .   |
| Position : 2.2 | Transport Vehicle 'B' to collect Shell Segment (with tacked-in Tee Bar segments) from Positioner, deliver and deposit same into Buffer Zone.            |

## STAGE II

### WORK PERFORMED

Assemble, Externally Tack and Internally Root Weld Shell Plate Segments to Shell Rings. Following External Back Gouging, if required, complete Longitudinal Seams Externally and Internally within the most suitable sequence.

### PRODUCTION EQUIPMENT

- a. Vertical Assembling Carousel.
- b. Self Propelled Tilttable Loading Carriage.
- c. External and Internal Longitudinal Seam Welding Facility.
- d. External Back Gouging Equipment.
- e. The Shipyard Crocodile vertically applied.

### SEQUENCE

- |                |  |
|----------------|--|
| Position : 3.1 | Transport Vehicle '8' picks up Shell Segments from Buffer Zone to . . .  |
| Position : 3.2 | transport and load Segments onto Vertical Assembling Fixture until Shell Ring is completed in a suitable manner to . . .   |
| Position : 4.1 | Align, Tack Weld (externally) Plate edge to Plate edge and . . .   |
| Position : 5.1 | weld Internal Seam in Vertical Up-Mode (say 3 runs only) Back Gouge external tacks, if required, and carry out Internal and External Seam Welding operation in the most suitable sequence. |
| Position : 5.2 | Lift Shell Ring out of Assembly Fixture by Shop Crane and transfer same onto Positioner in Stage IIIA.   |

# STAGE IIIA

## WORK PERFORMED

Clamp Shell Ring onto Positioner, grind Internal Longitudinal Seams flush with Shell surface, load and tack Tee Bar make-up pieces into gaps between Tee Bar Segments already installed at Stage I. Weld Tee Bar Flanges on one side of Web Joints. Load Shell Ring onto Transport Vehicle (C) for transfer into Stage IIIB.

## PRODUCTION EQUIPMENT

- a. Vertically adjustable Positioner with tiltable (360°) Rotary Table.
- b. Shipyard Crocodile.
- c. Tee Bar Loader.
- d. Portable Staging for Welders.
- e. Transport Vehicle (C)

## SEQUENCE

- |                |  |
|----------------|--|
| Position : 6.1 | Lower Turntable within its horizontal plane to loading position and load Shell by Shop Crane.  |
| Position : 6.2 | Clamp Shell externally, raise Turntable to turning height and tilt anti-clockwise through 90° to vertical plane.   |
| Position : 7.1 | With Grinder mounted on 'Crocodile' grind all internal welds flush. On completion of Grinding Operation use . . .  |
| Position : 7.2 | the Crocodile to take Tee Bar make-up Segments from Tee Bar Loader and deposit same into gaps between Tee Bar Segments previously installed in Stage I. On completion of depositing and tacking the make-up Segments . |

/contd.

STAGE IIIA  
(Continued)

SEQUENCE (contd. )

- Position : 8.1      tilt Turntable clockwise through 90° to face-up horizontal position and lower to working height.
- Position : 8.2      Mount staging for welders onto Turntable and weld manually one side of Tee Bar joints and some Flange joints.      On completion remove staging.
- Position : 9.1      Raise Turntable to tilting height and tilt clockwise through 180° to horizontal face-down position.
- Position : 9.2      Drive Transport Vehicle 'C' underneath Shell, lower Turntable until Shell rests in Vehicle and release clamping.
- Position : 9.3      Raise Turntable to give free passage to Vehicle 'C' and transport Shell to Buffer Zone.

STAGE IIIB

SEQUENCE

- Position : 9.4      Transport Shell Ring from Stage IIIA and deposit same onto Buffers. Mount staging for Welders onto Buffer Zone and weld manually second side of Tee Bar joints.      On completion remove staging.

## STAGE IIIC

### WORK PERFORMED

Continuously Weld Toe of Tee Bars to Shell Plates from both sides simultaneously and two Tee Bars at a time. Unload onto Buffer Zone on completion.

### PRODUCTION EQUIPMENT

- a. Vertically Adjustable Positioner with Tilttable Rotary Table.
- b. Multi-Head Welding Manipulator.
- c. Transport Vehicle D.

### SEQUENCE

- |                 |   |
|-----------------|---|
| Position : 10.1 | Move Internal Circwelder into side parking place (X) to give free passage for . . .   |
| Position : 10.2 | Transport Vehicle 'C' transferring and mounting Shell Ring from Buffer Zone B to Positioner with Table face down.   |
| Position : 10.3 | Withdraw Transport Vehicle 'C' into Buffer Zone in Stage IIIB.  |
| Position : 11.1 | Raise Turntable holding Shell Ring up to tilting position and tilt same 90° anti-clockwise to face Buffer Zone in Stage IIIB.                             |
| Position : 11.2 | Move Internal Circwelding Machine of multiple head construction (2 x tandem) into welding position and finish welding Tee Bar Stiffeners into Shell Ring. |
| Position : 11.3 | Transfer Internal Circwelding into side parking place (X).  |
| Position : 12.1 | Tilt Turntable clockwise through 180° to face opposite direction.   |
| Position : 12.2 | Drive Transport Vehicle 'D' underneath Shell Ring, release clamping and unload Shell Ring onto Transport Vehicle 'D'.                                     |
| Position : 12.3 | Transport Shell by Vehicle 'D' to Buffer Zone for Shell Ring to Shell Ring assembly using Shop Crane to hold Shell for safety reasons.                    |
| Position : 13.1 | Buffer Zone with Transport Vehicle 'D'.   |

C : ILLUSTRATIONS

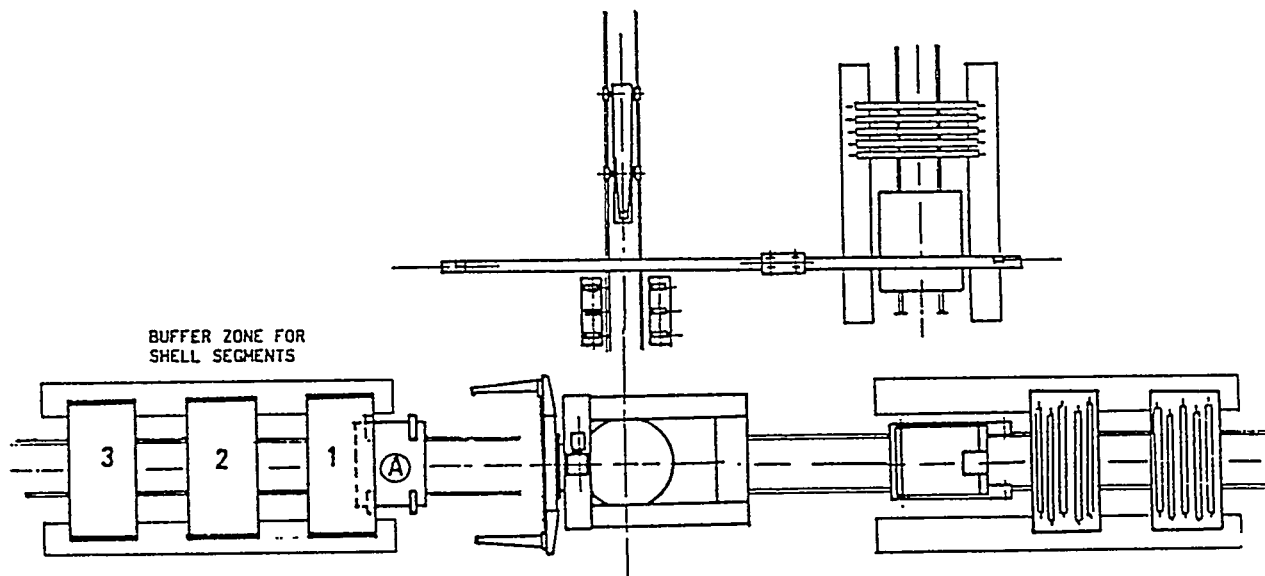
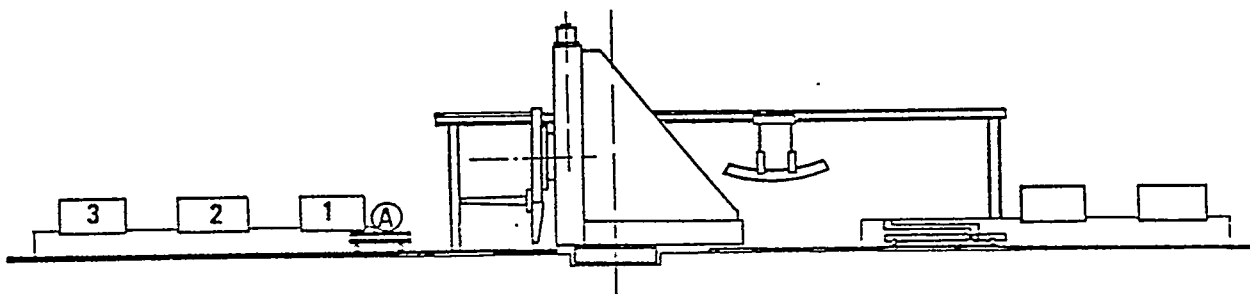
STAGE IPOSITION 1.1.

Buffer Zone for Shell Segments.

STAGE I

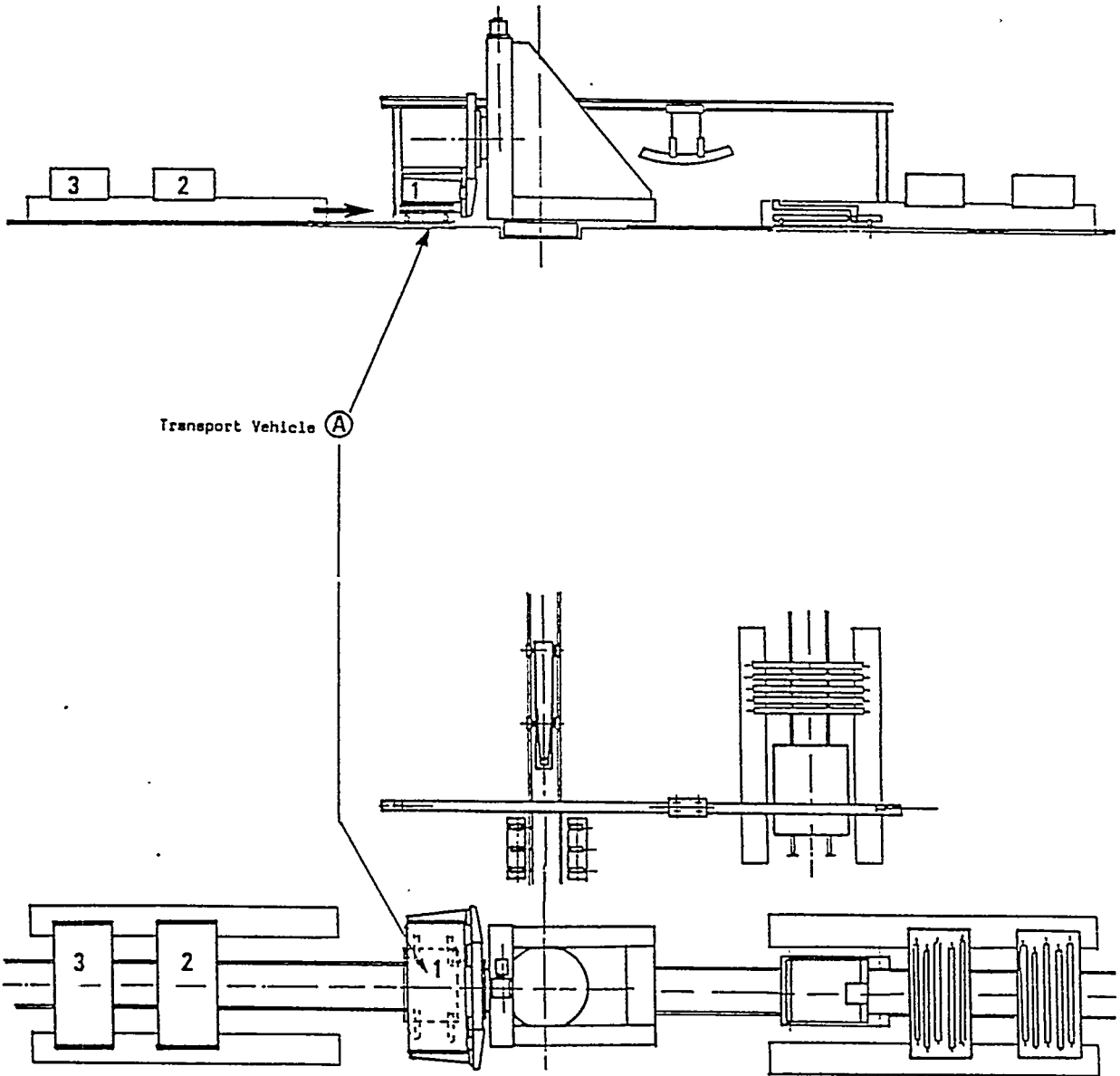

POSITION 1.2.

Shell segment No. 1 loaded by Transport Vehicle A onto Rotary Positioner

STAGE I

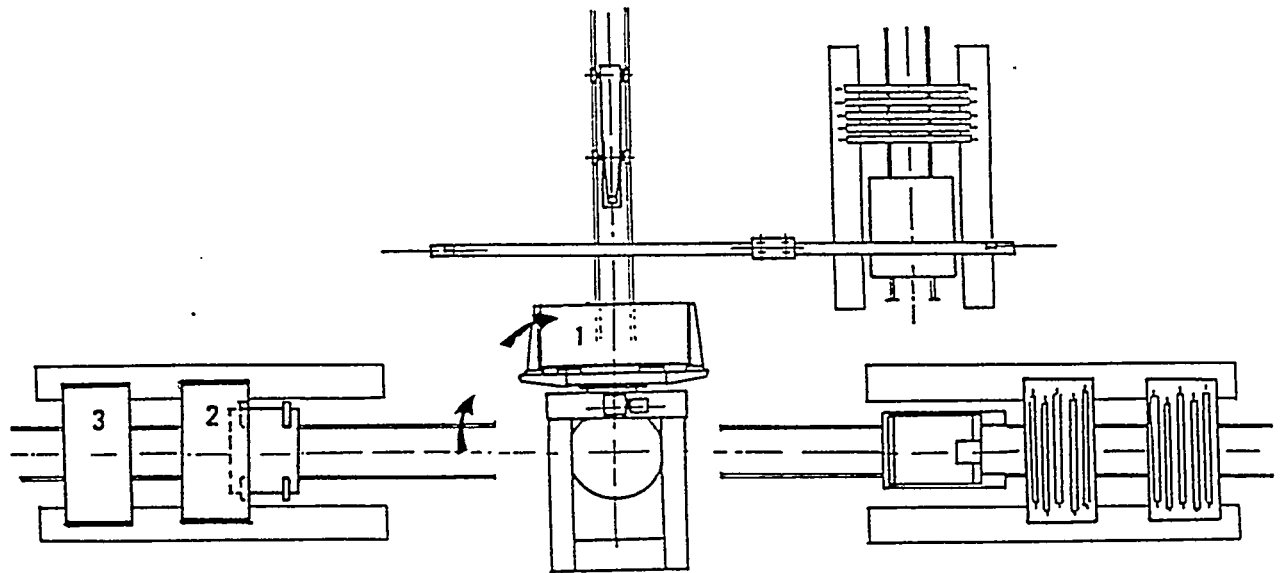
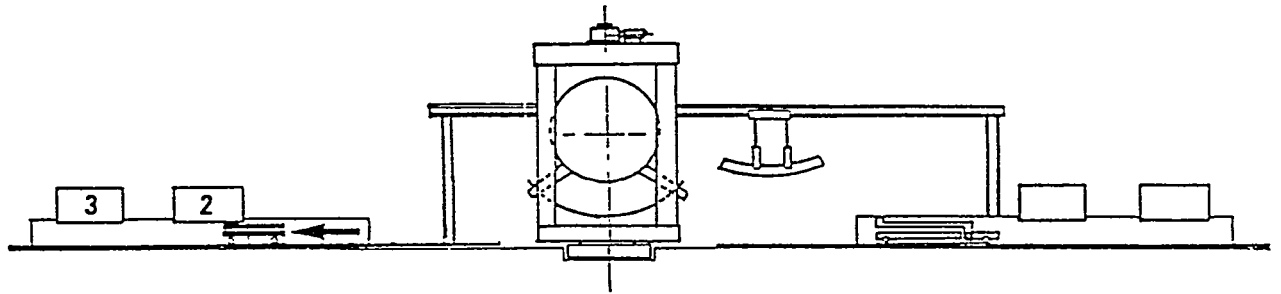

POSITION 1.3.

Turn Rotary Positioner clockwise through 90°  
for Tee Bar segment loading

STAGE I

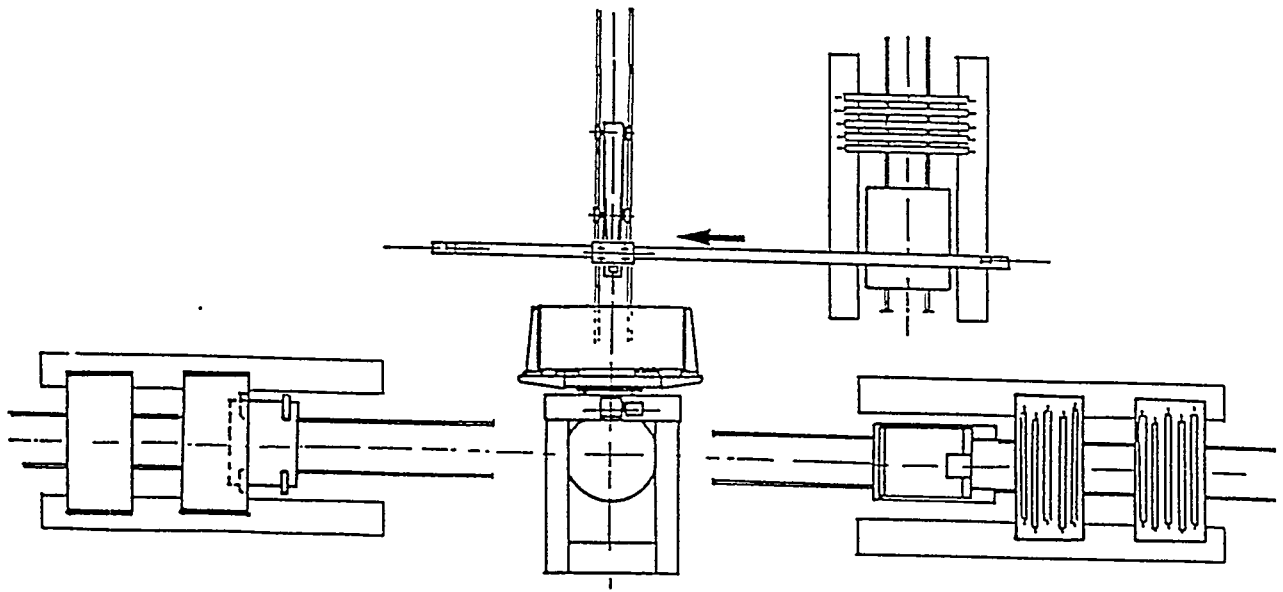
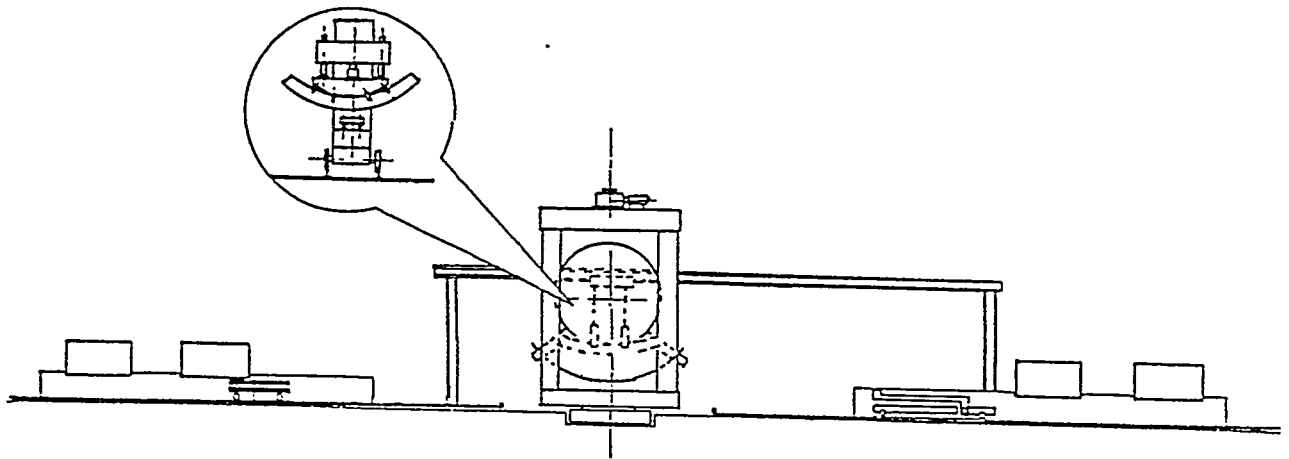

POSITION 1.4.

Assembling machine, Type: 814 S 'The Crocodile' to take segments from T-Bar Loader.

## STAGE I

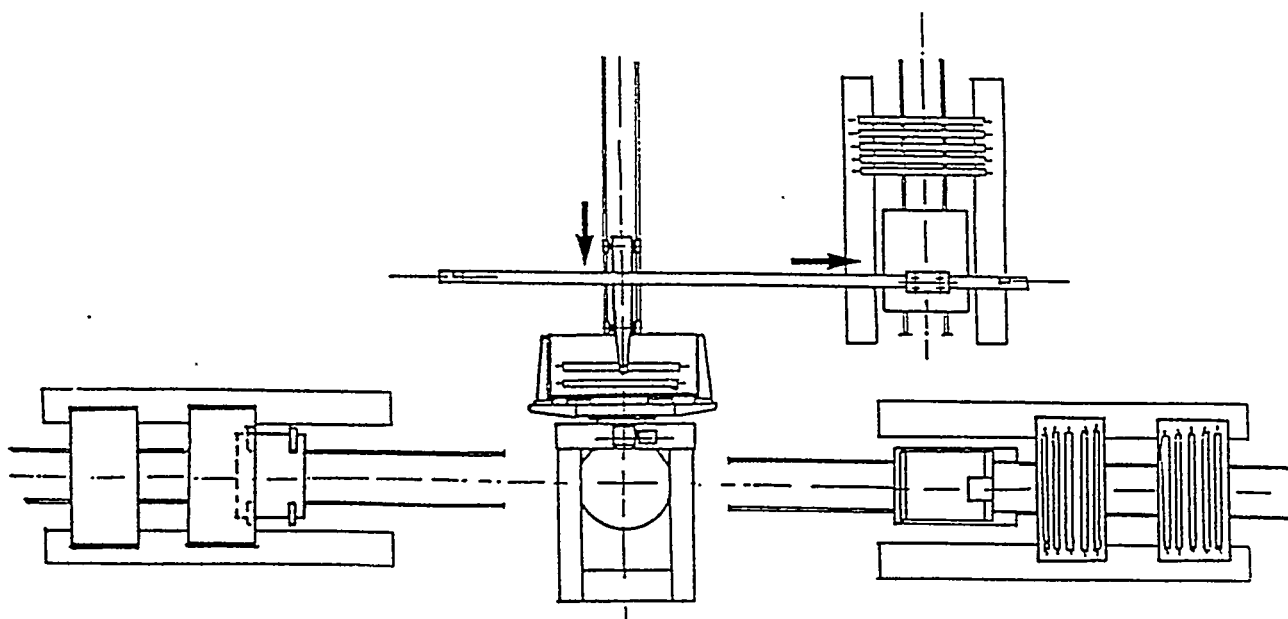
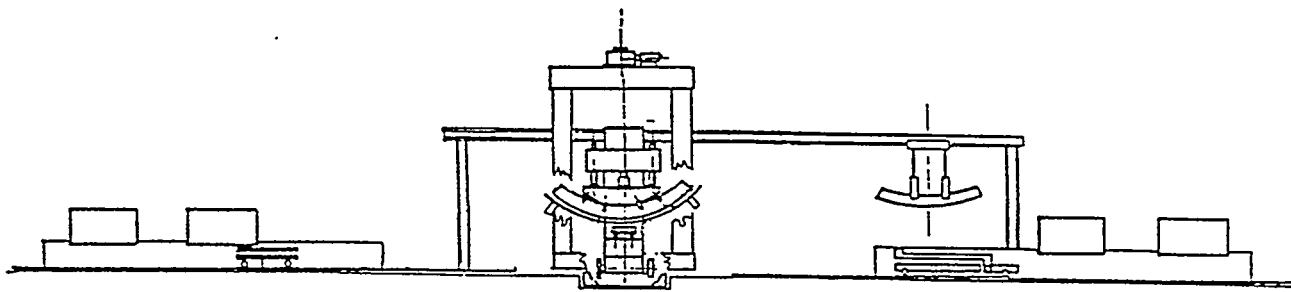

### POSITION 1.5.

Crocodile to insert, clamp and tack weld Tee Bar segments  
into shell segment (number according to requirement)

## STAGE I

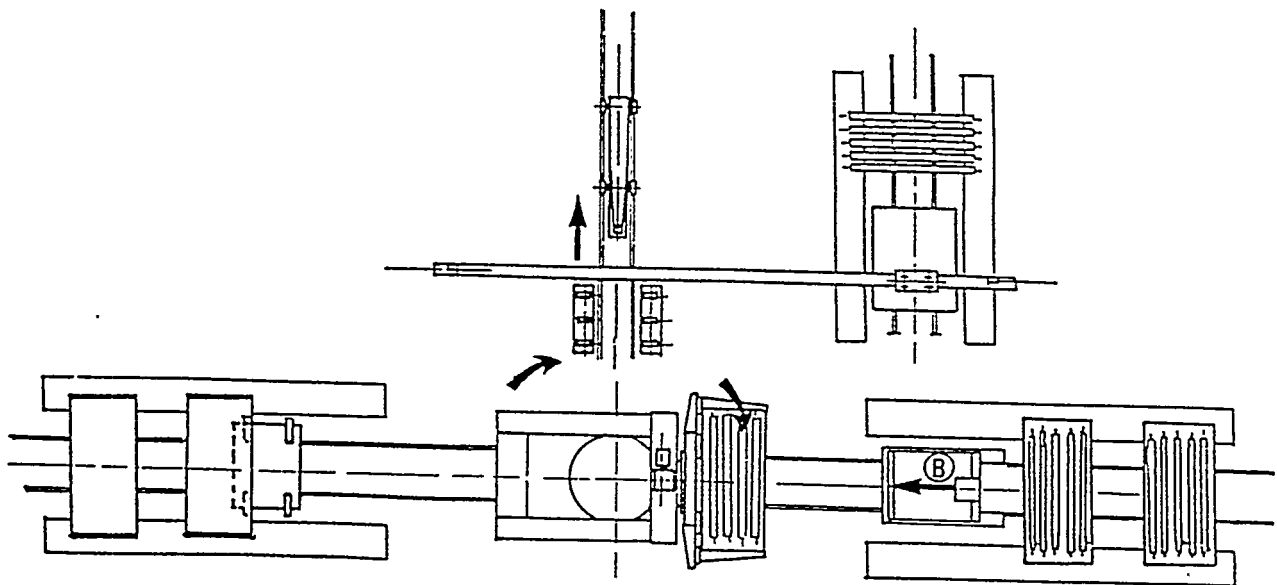
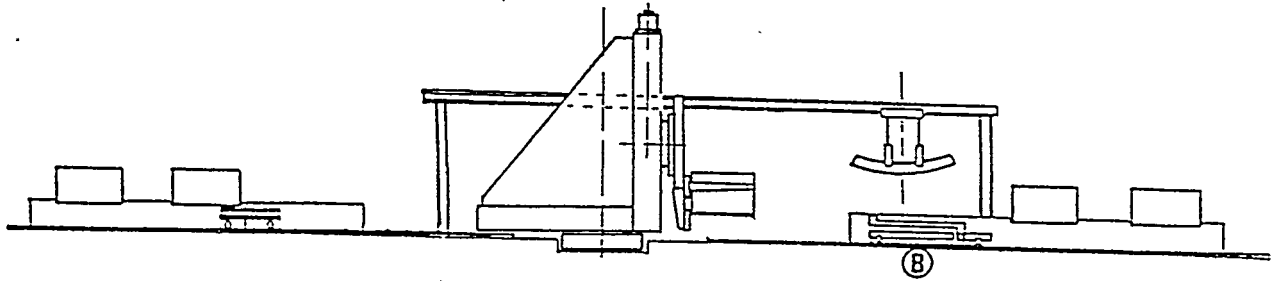

### POSITION 2.1.

Turn Positioner Clockwise through 90° for discharge Shell Segment with Ice Bar Segments onto Transport Carriage 'B', deliver into Buffer Zone

## STAGE I

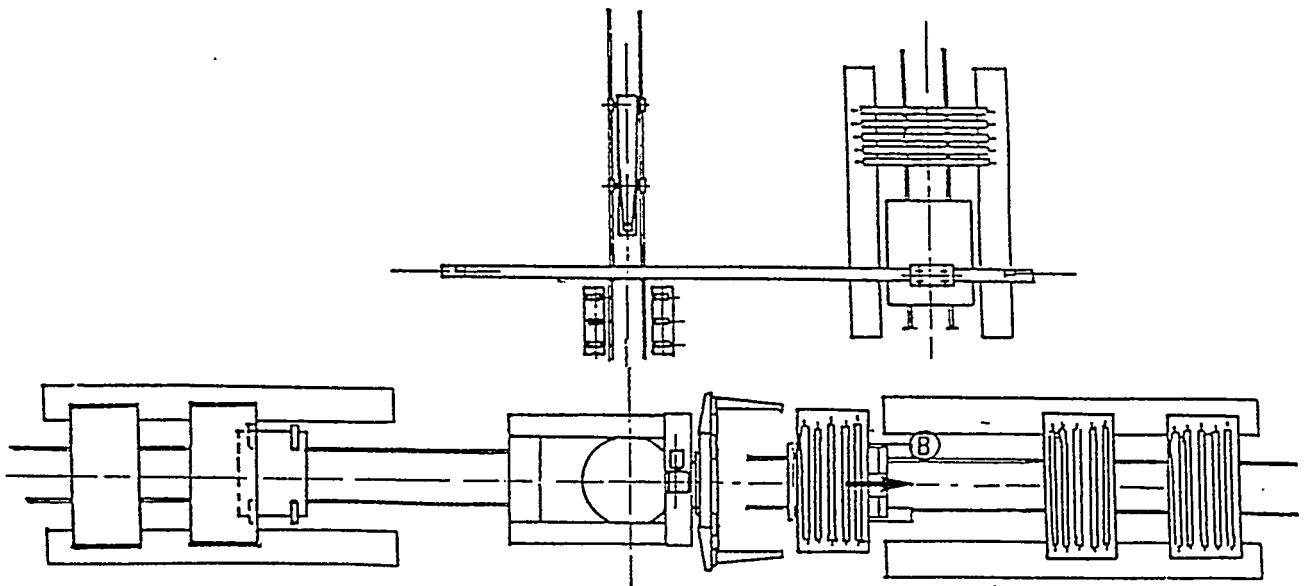
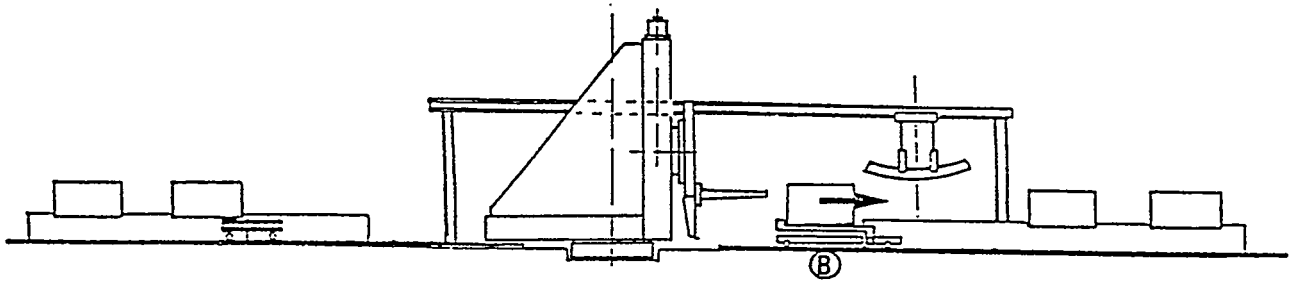

### POSITION 2.2.

Transport Vehicle (B) to collect shell segments.  
(with tacked-in T-Bar segments)  
from Cradle and deposit them in Buffer Zone.

## STAGE II

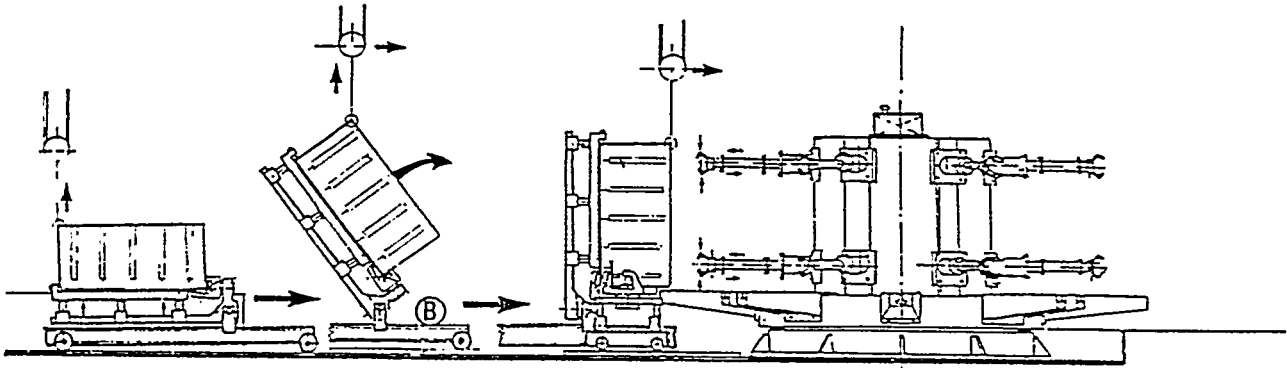

### POSITION 3.1.

Transport Vehicle (B) to pick up shell segments from Buffer Zone.

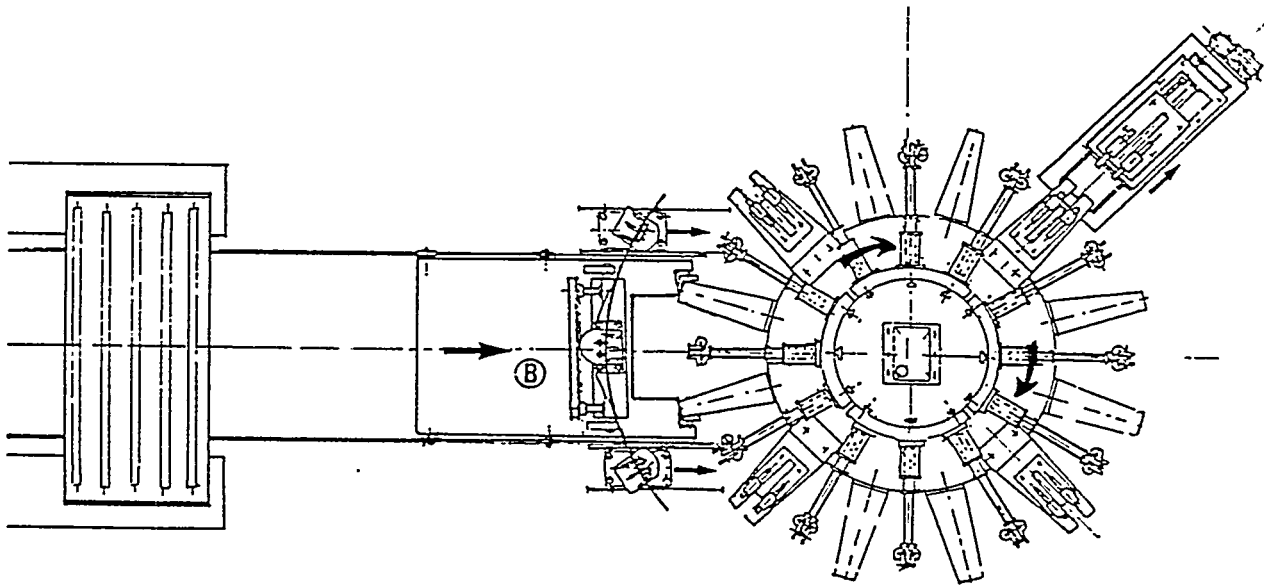

### POSITION 3.2.

Transport shell segments on Vehicle (B) and load onto Vertical Assembling Fixture [ 4 times]

STAGE II

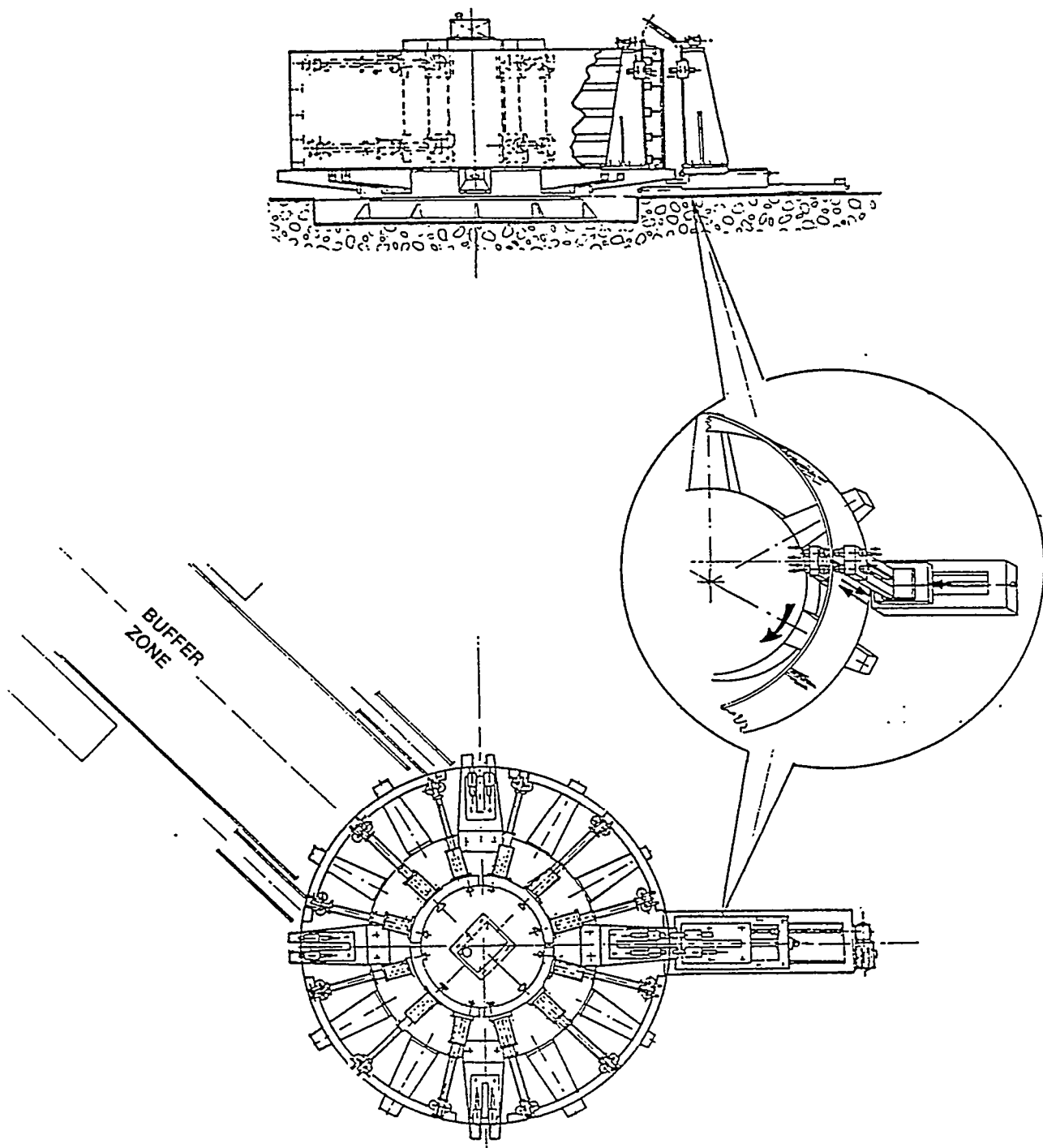

POSITION 4.1.

Align and Tack Weld Longitudinal Seam Externally

STAGE II

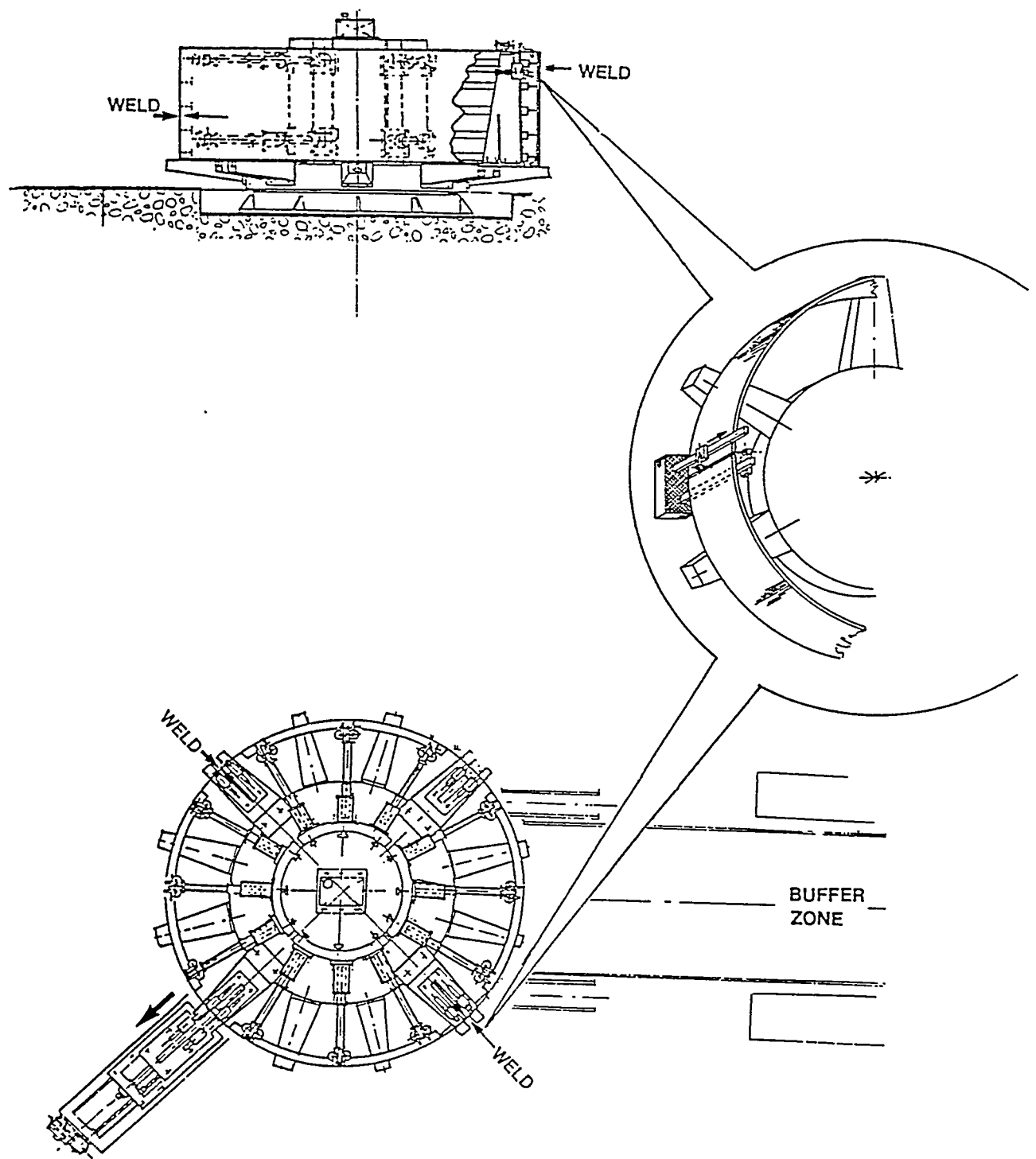

POSITION 5.1.

Weld Internal Seam in Vertical Up-Mode (3 Runs only)  
Carry out External Back Gouging.  
Carry out Internal and External Seam Welding  
simultaneously.

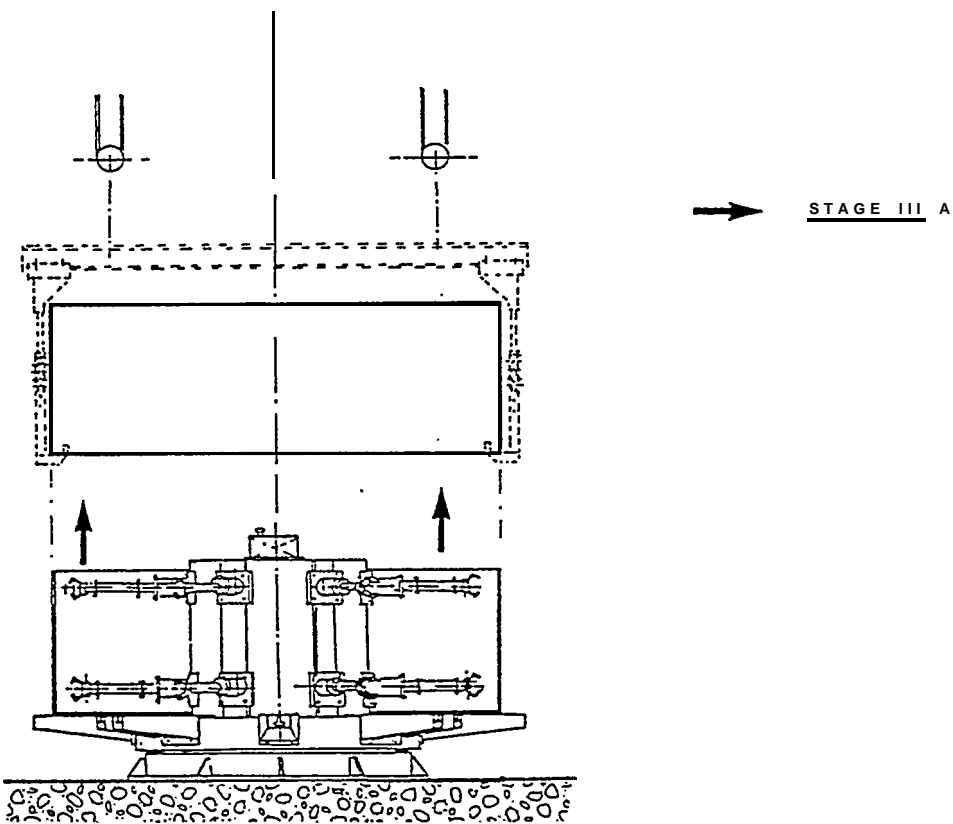
STAGE IIPOSITION 5.2.

Lift shell assembly out of Assembly Fixture by Shop Crane.

## STAGE IIIA

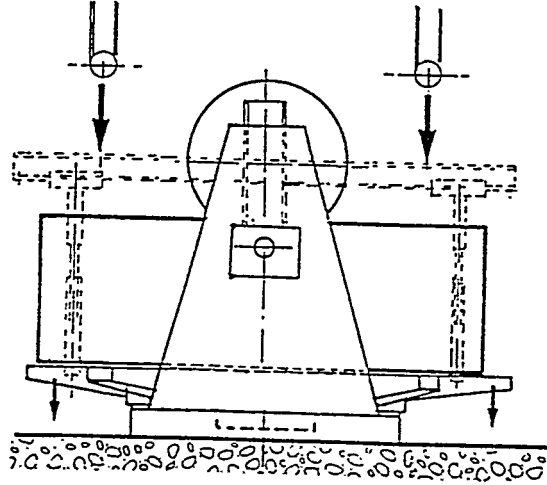

### POSITION 6.1.

Lower Turntable to loading position [1 m height above floor level] within horizontal plane and load shell by Shop Crane.

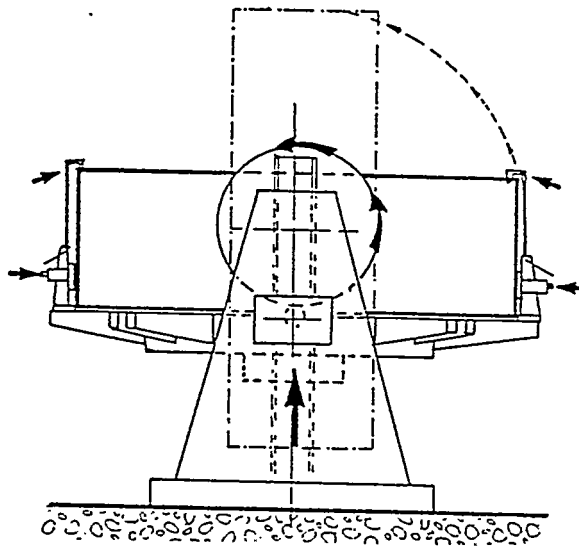

### POSITION 6.2.

Clamp shell externally, raise Turntable to turning height and tilt anti-clockwise through 90° to vertical plane.

### STAGE IIIA

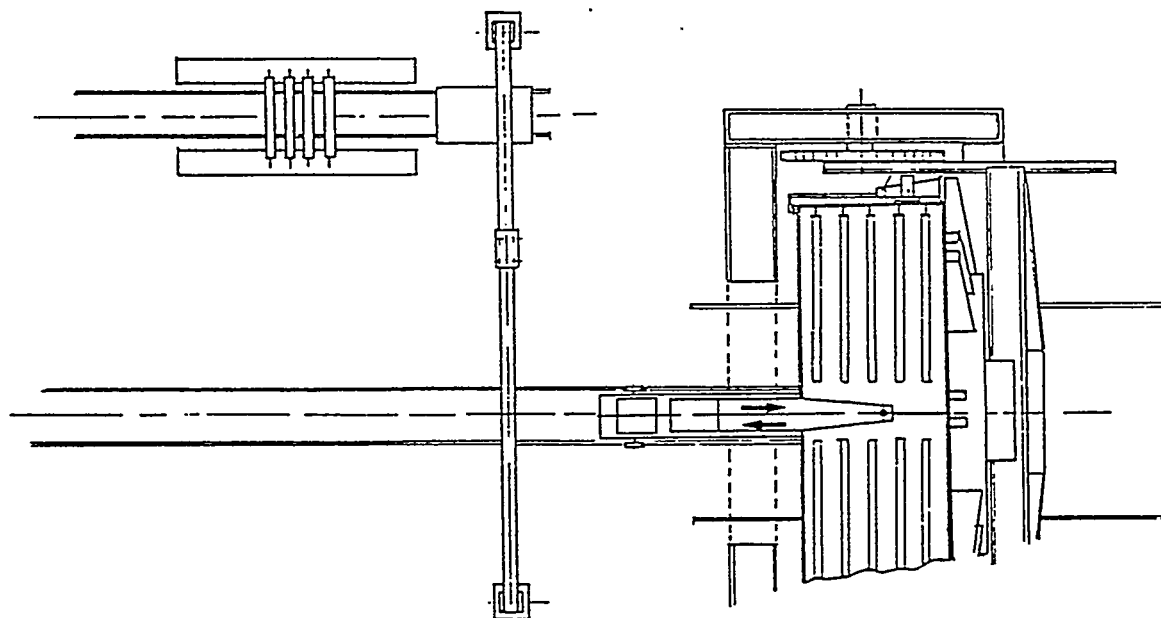
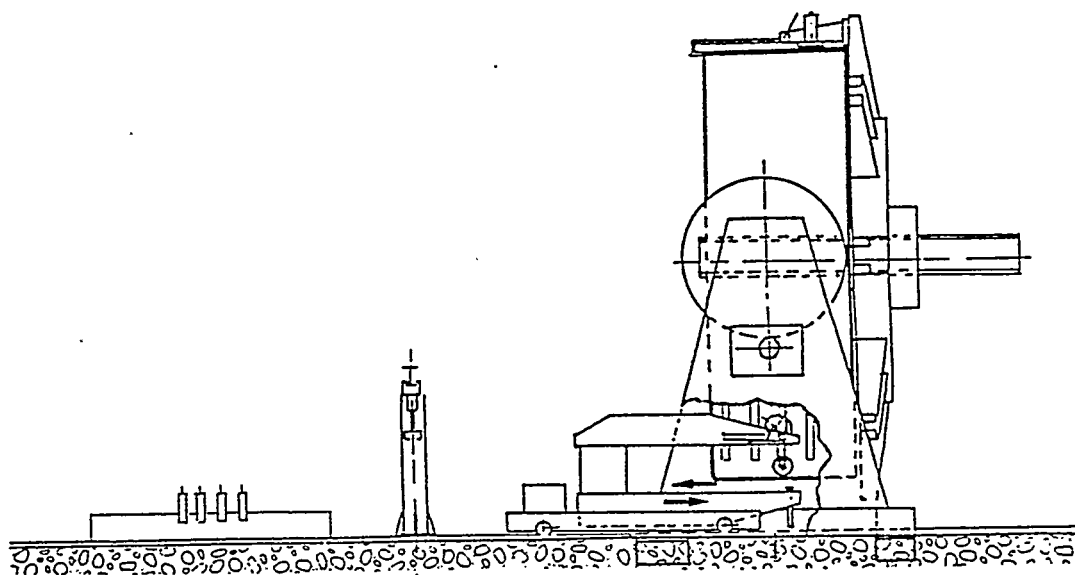

### POSITION 7.1.

With Grinder mounted on 'Crocodile' grind internal welds flush.

STAGE IIIA

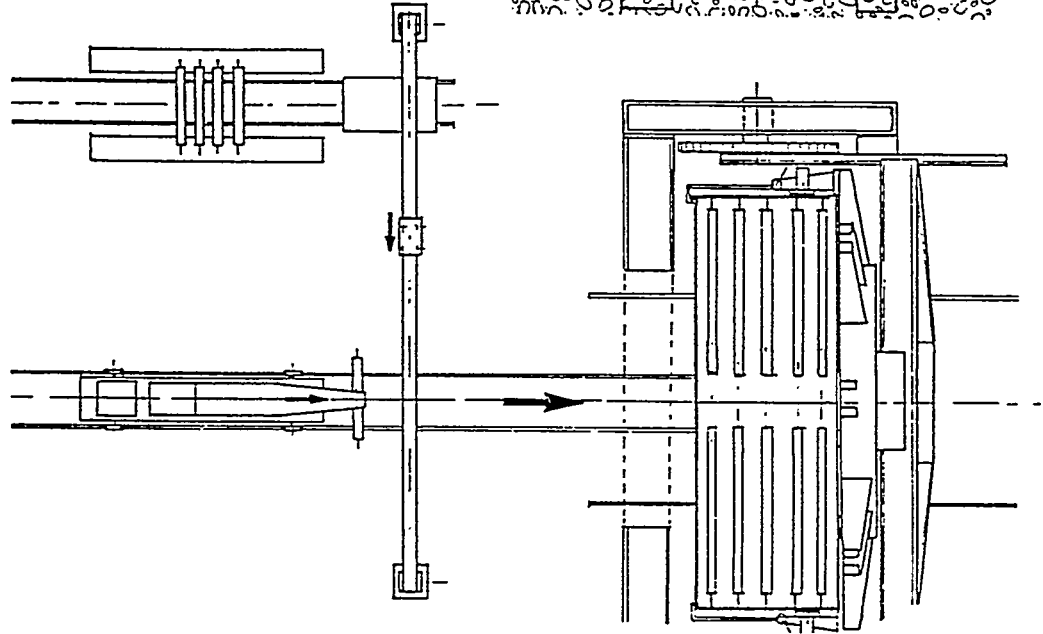
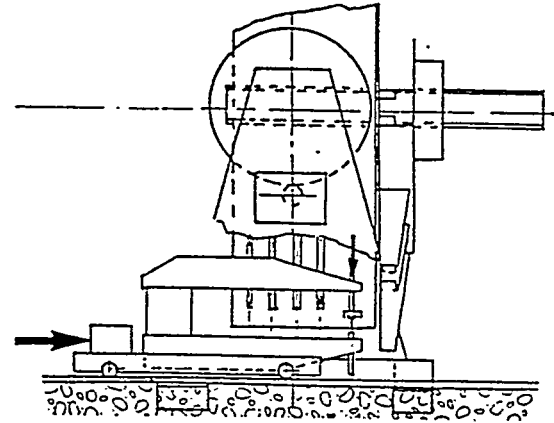
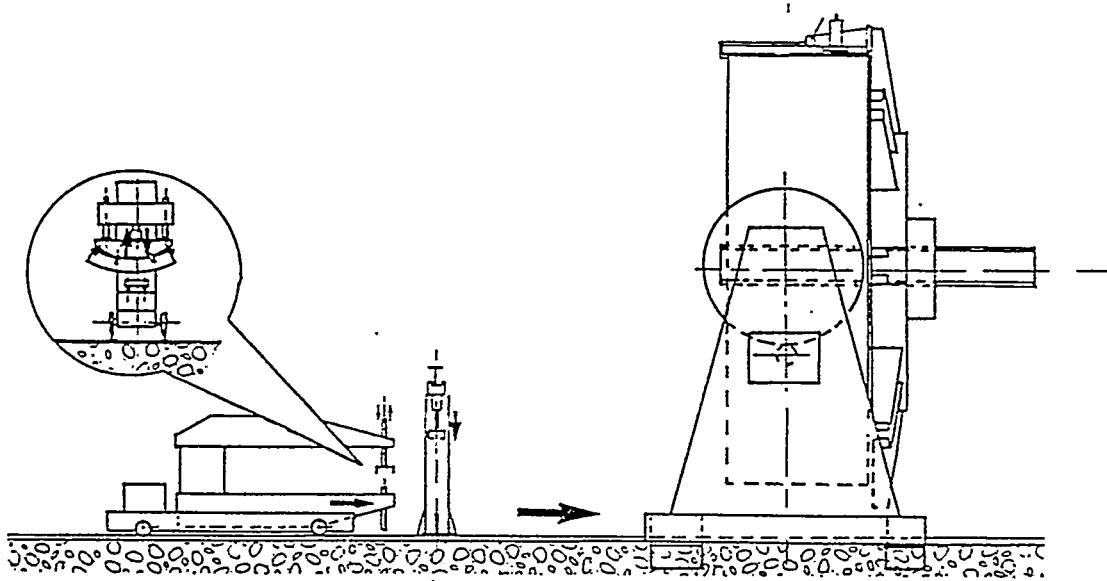

POSITION 7.2.

The Crocodile to take T-Bar make-up segments from T-Bar Loader.

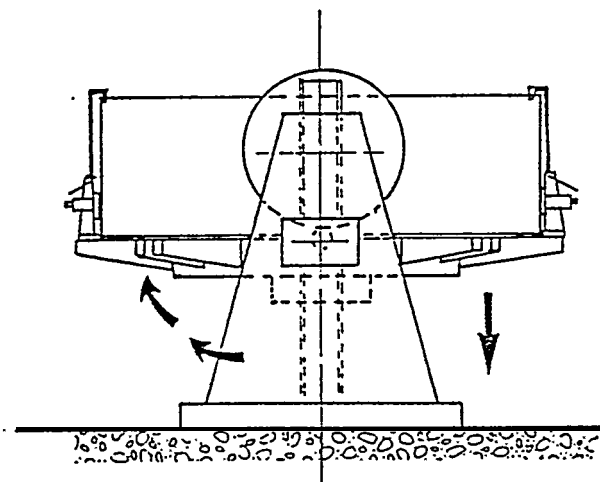
STAGE IIIAPOSITION 8.1.

Tilt Turntable clockwise through 90° to face-up horizontal position and lower to working height.

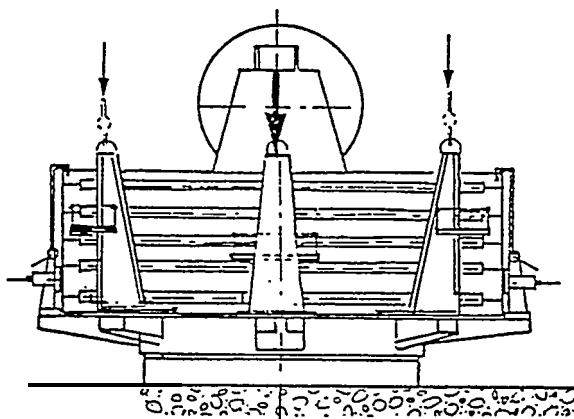
POSITION 8.2.

Instal work platforms for Welders by Shop crane. Weld manually part of T-bar Butt Welds.

### STAGE IIIA

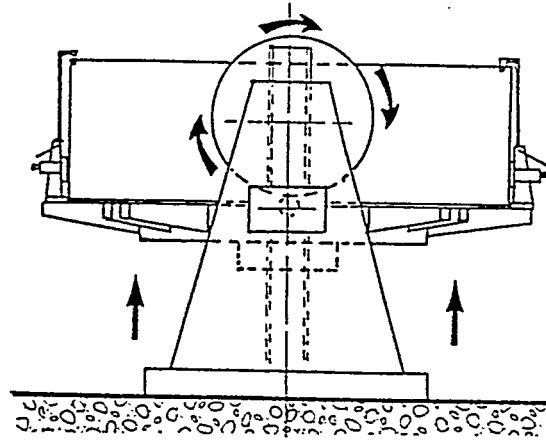

**POSITION 9.1.**

Remove work platforms, raise Turntable to tilting height and tilt clockwise thro' 180° to horizontal face-down position.

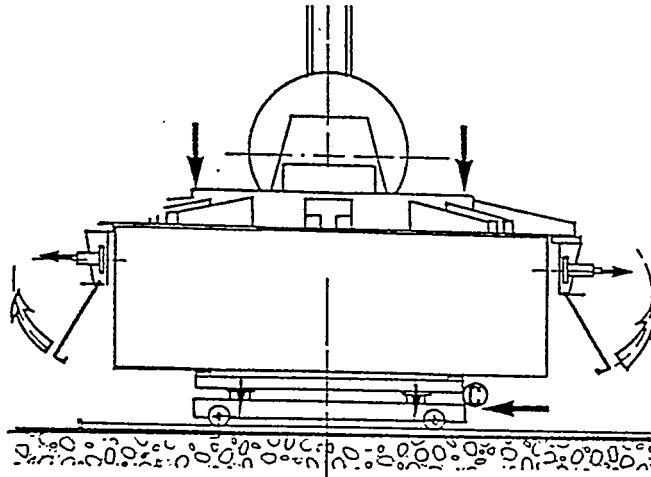

**POSITION 9.2.**

Drive Transport Vehicle © underneath shell, lower Turntable until shell rests on Vehicle and release clamping.

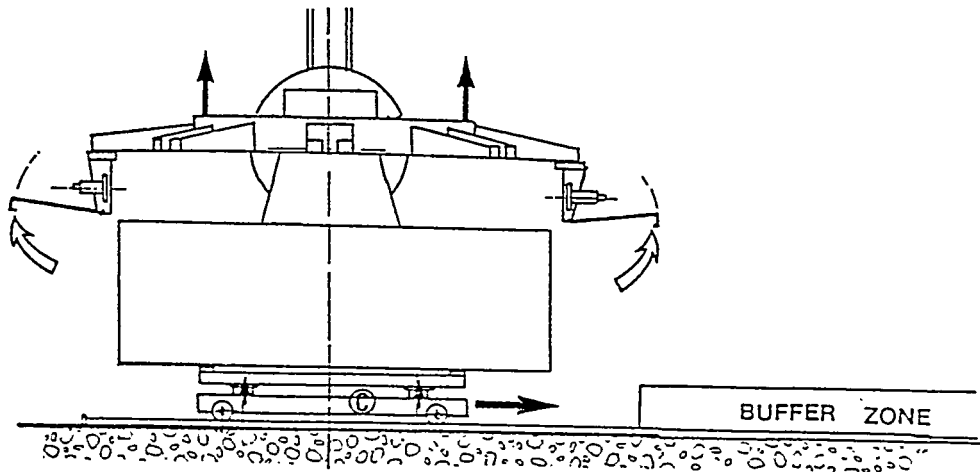

**POSITION 9.3.**

Raise Turntable to give free passage to Vehicle © and transport shell to Buffer Zone.

STAGE III B

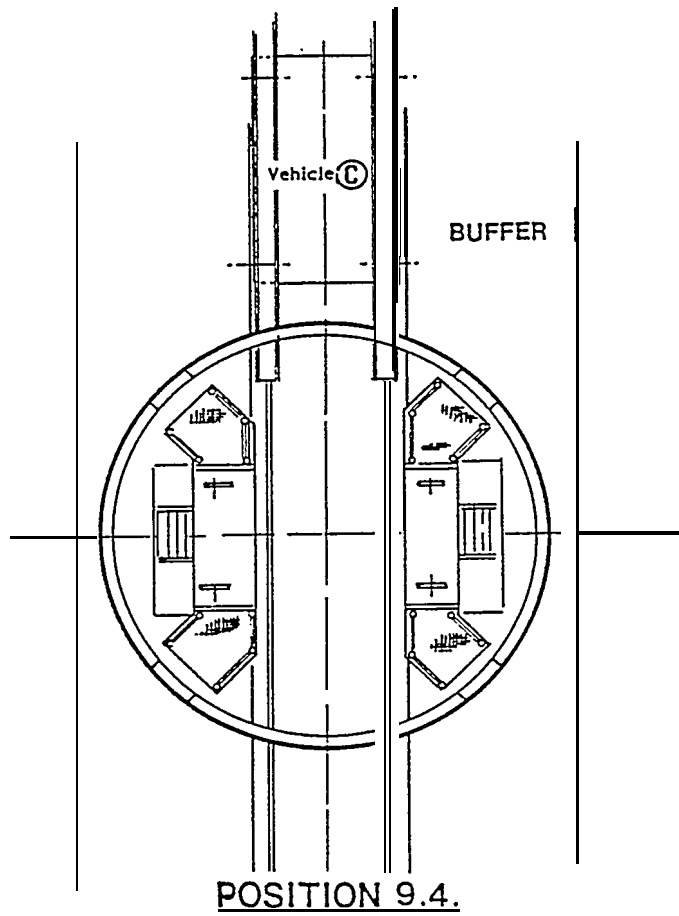
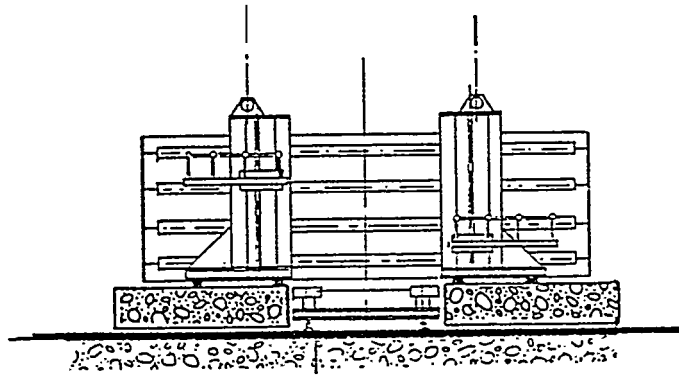

- Instal Welders works Platforms by Shop Crane.
- Weld manually second side of T-bar Butt joints.
- Remove Platforms on completion of welds.

STAGE III C

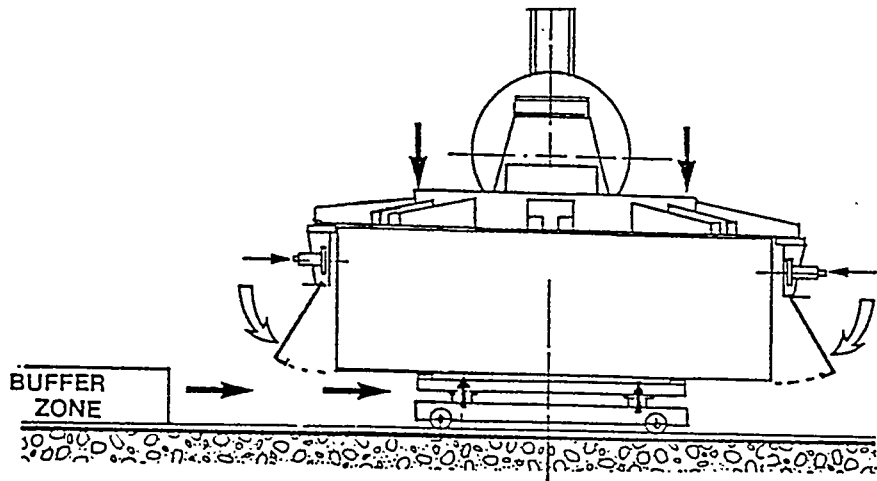

POSITION 10.2.

Lift Shell from Buffer with Transport Vehicle 'C' and mount shell on Positioner with table face down.

### STAGE III C.

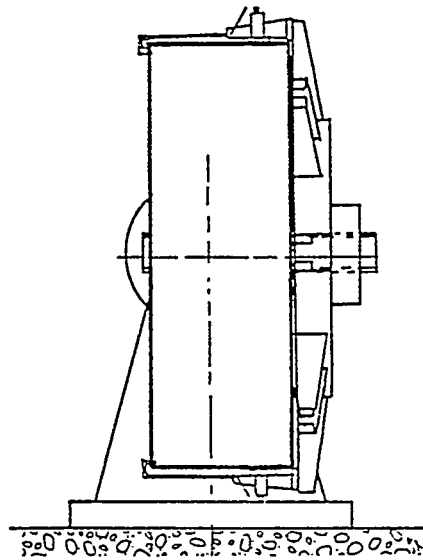
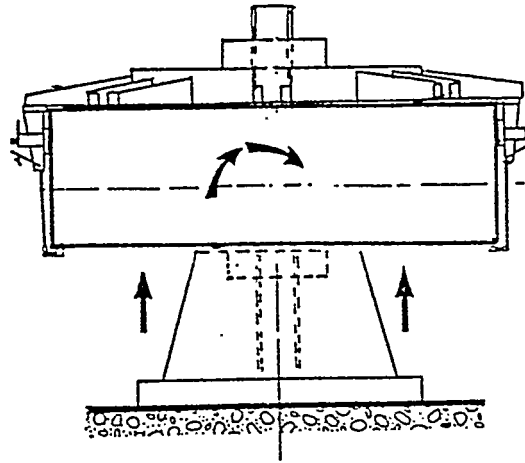

### POSITION 11.1.

Raise Turntable to tilting height and tilt clockwise through 90° into vertical plane.

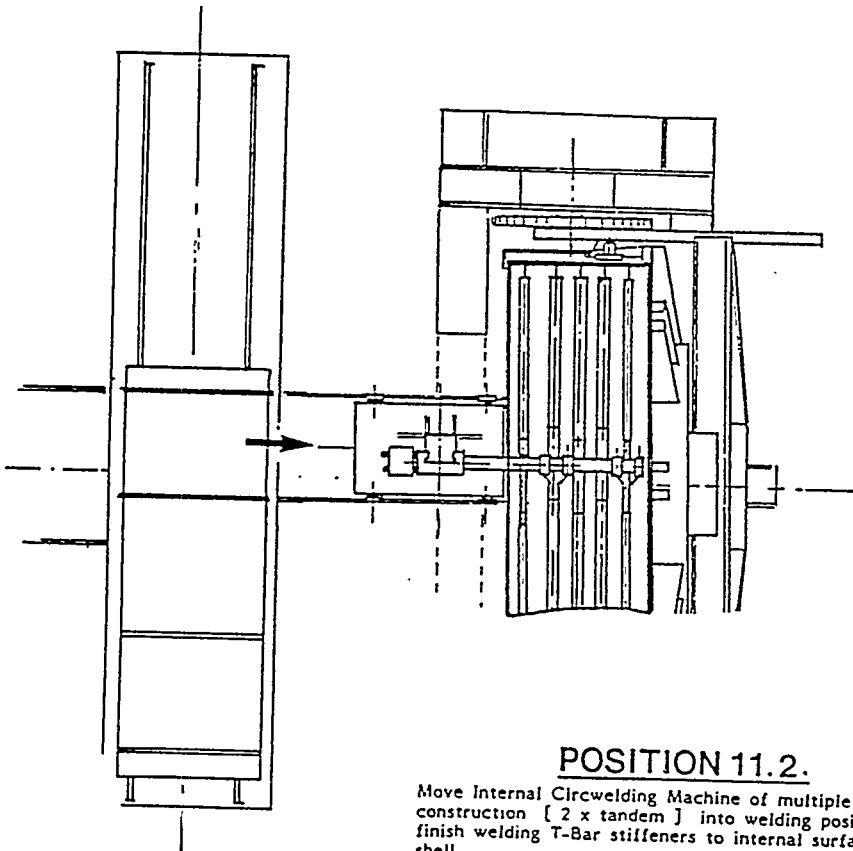
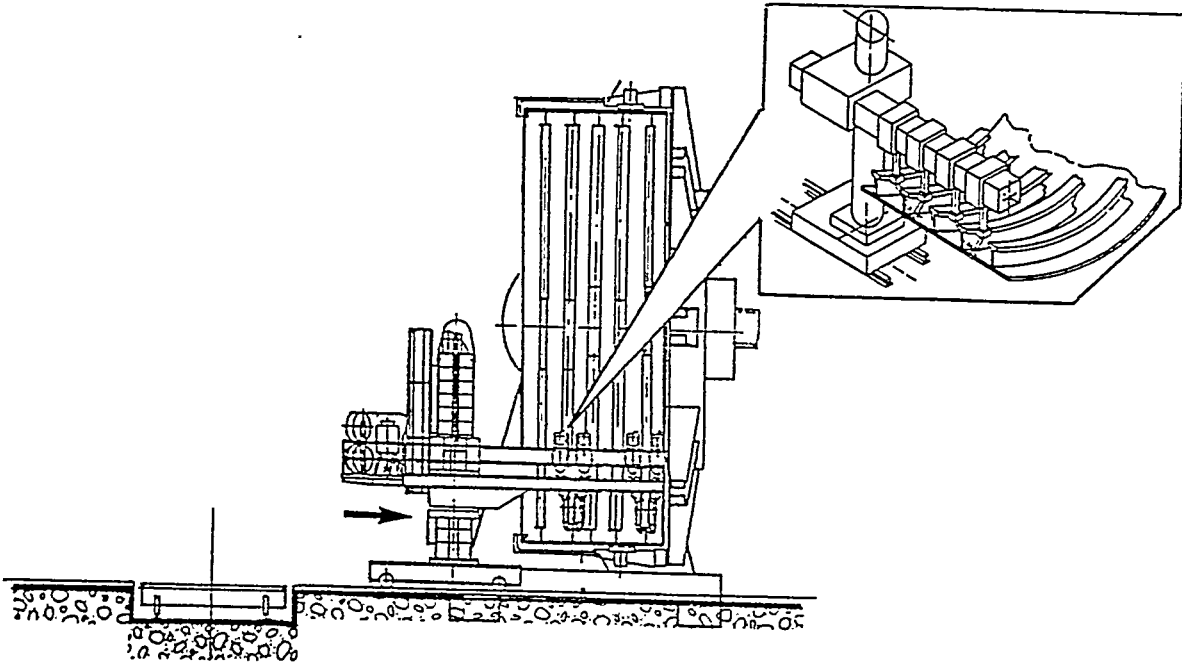
STAGE III CPOSITION 11.2.

Move Internal Circuwelding Machine of multiple head construction [ 2 x tandem ] into welding position and finish welding T-Bar stiffeners to internal surface of shell.

STAGE III C

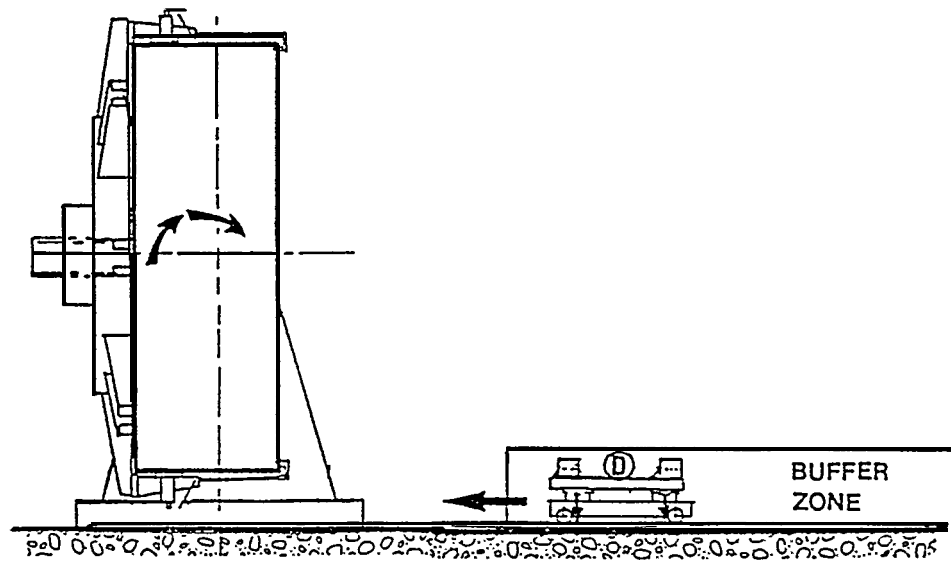

POSITION 12.1

Tilt Turntable clockwise through 180° to face in the opposite direction (vertical plane).

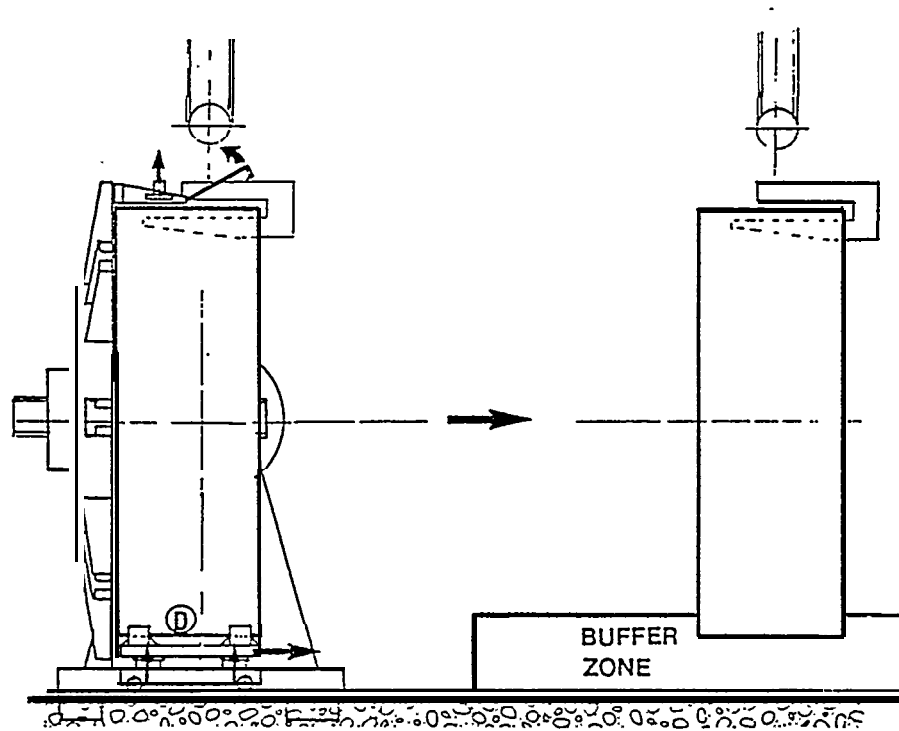

POSITION 12.2

Drive Transport Vehicle (D) underneath shell and release clamping.

Transport shell by Vehicle (D) to Buffer Zone, using Shop Crane to hold shell for safety reasons.



D : PHOTOGRAPHS

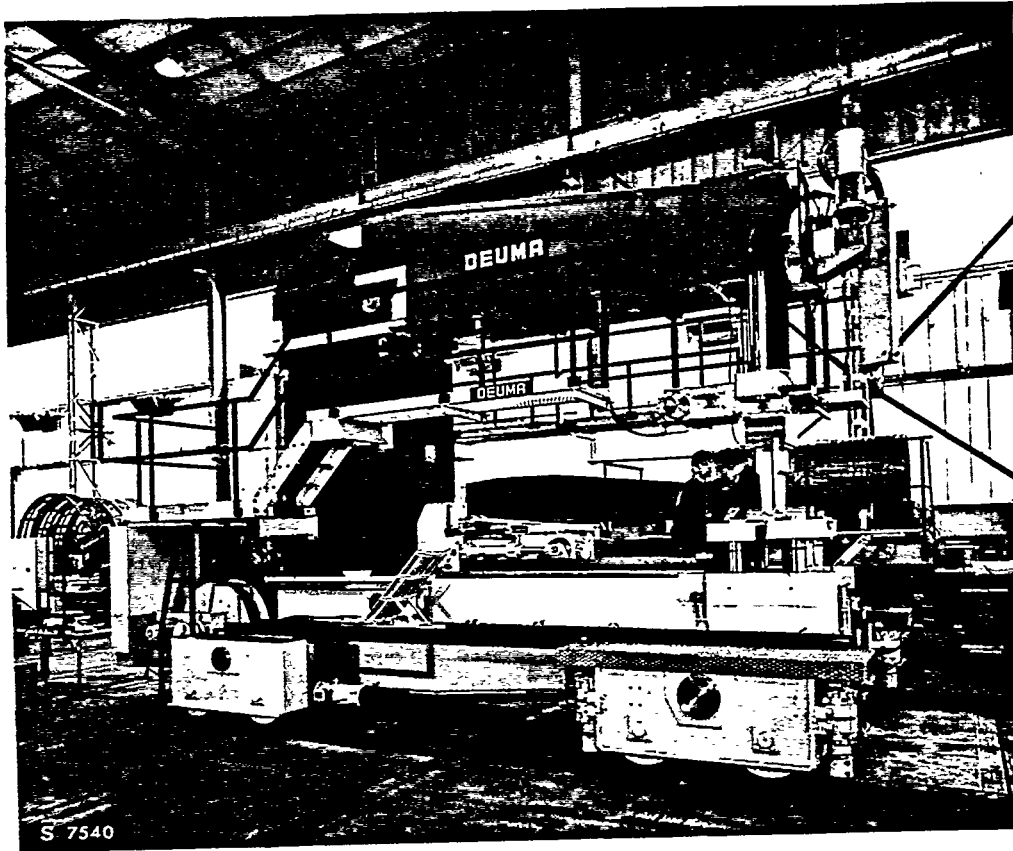

SHIPYARD CROCODILE - Type: 814 NS  
EXTRA LARGE DIAMETER REINFORCED SHELL RING PRODUCTION

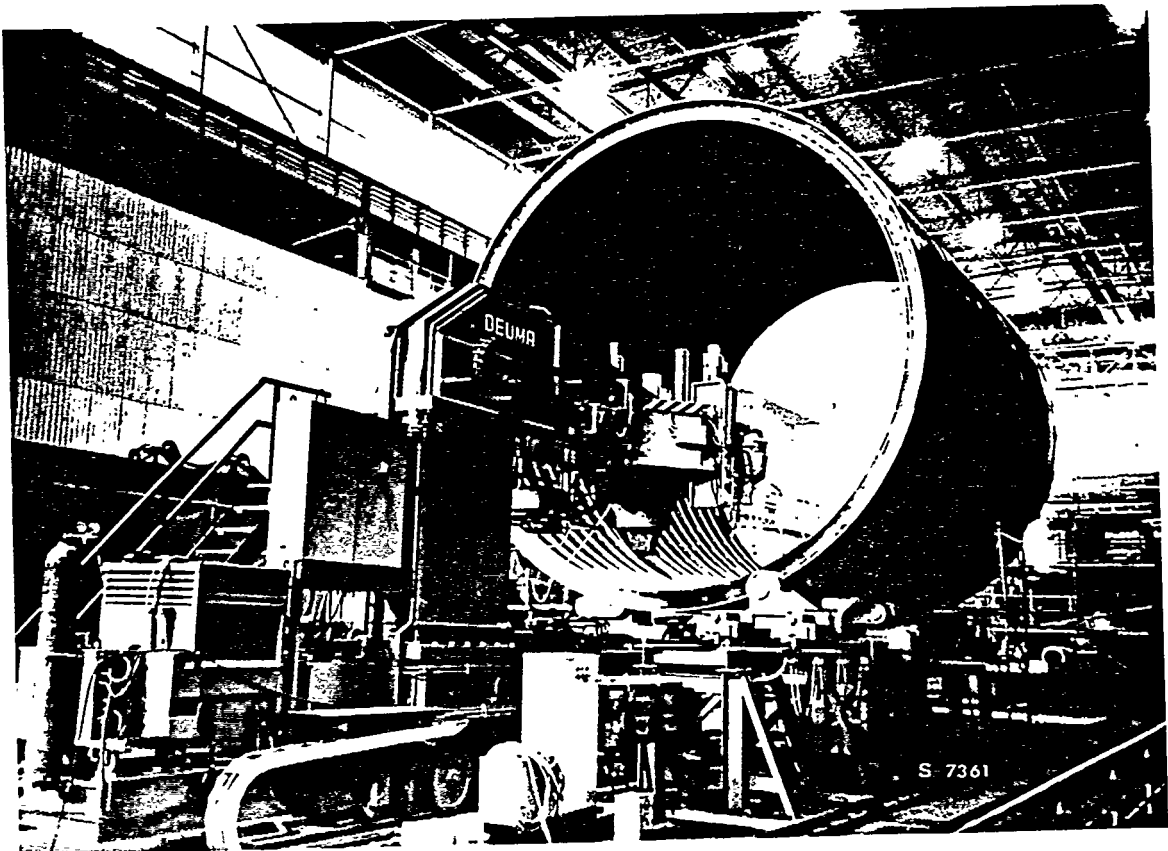

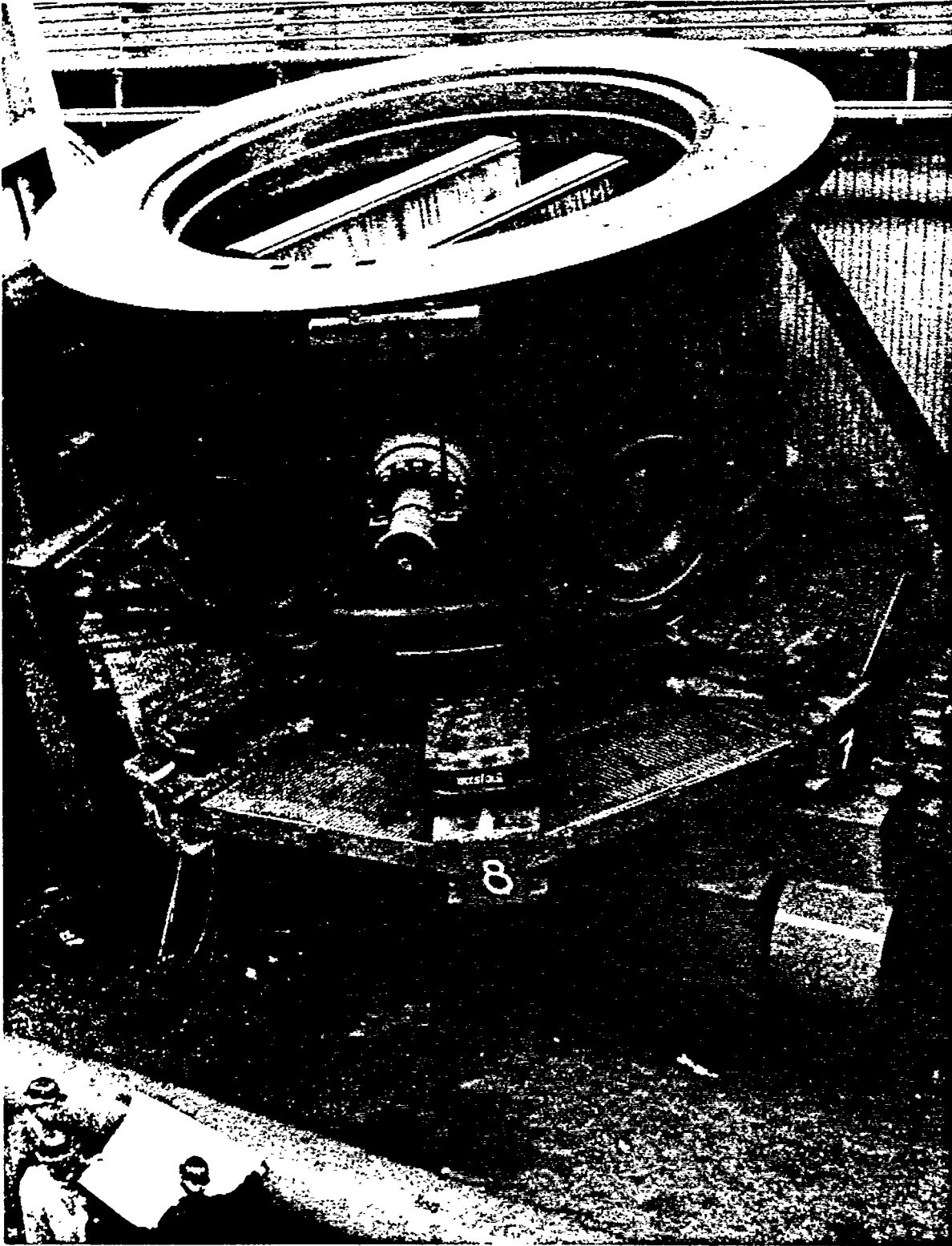

ROTARY POSITIONER

WORKPIECE 275 US TONS : 30FT. IN DIAMETER  
NUCLEAR REACTOR PRODUCTION

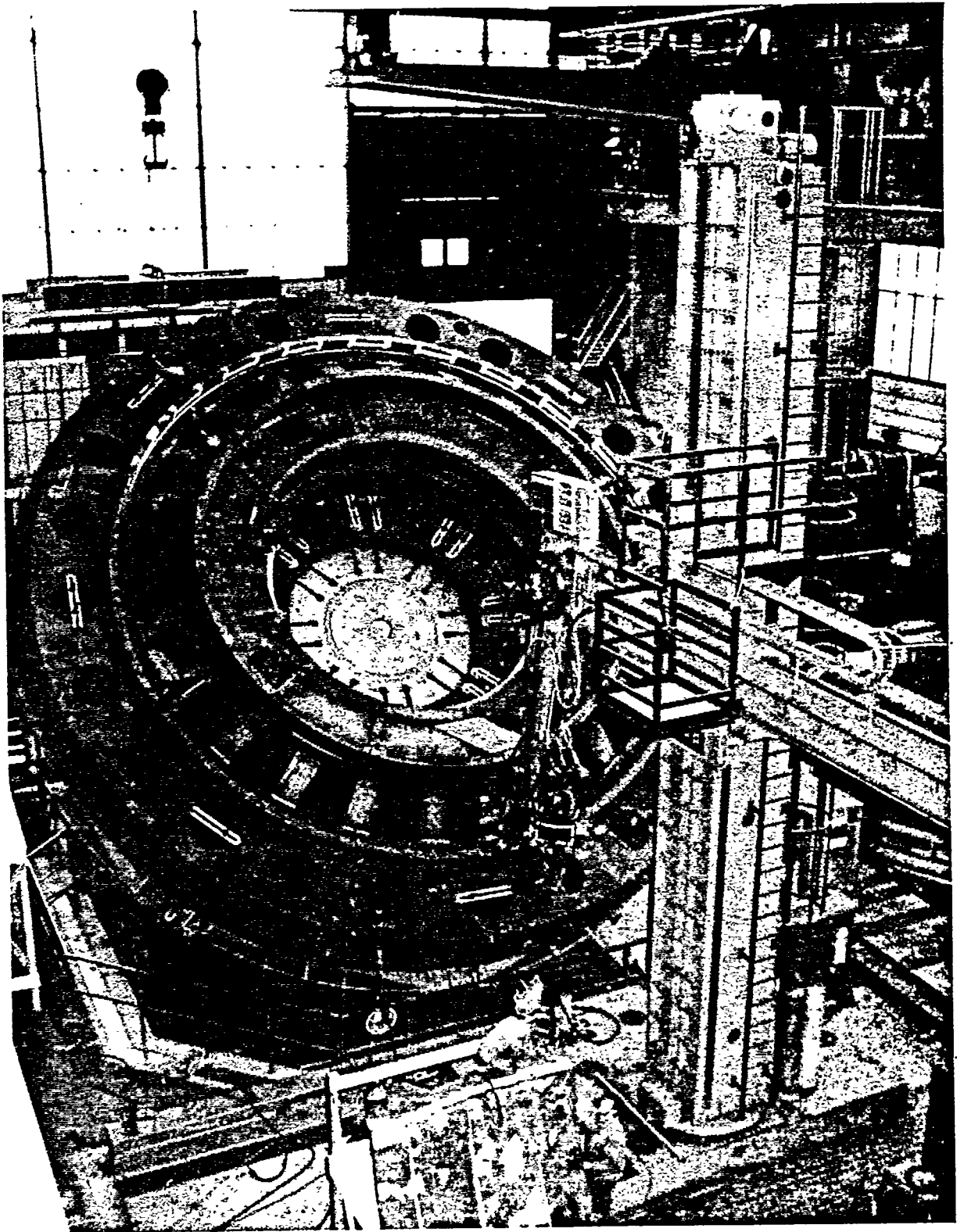

ROTARY POSITIONER WITH CO-ORDINATED WELDING MANIPULATOR  
WORKPIECE 286 US TONS IN WEIGHT : 36FT. IN DIAMETER

WATER TURBINE PRODUCTION

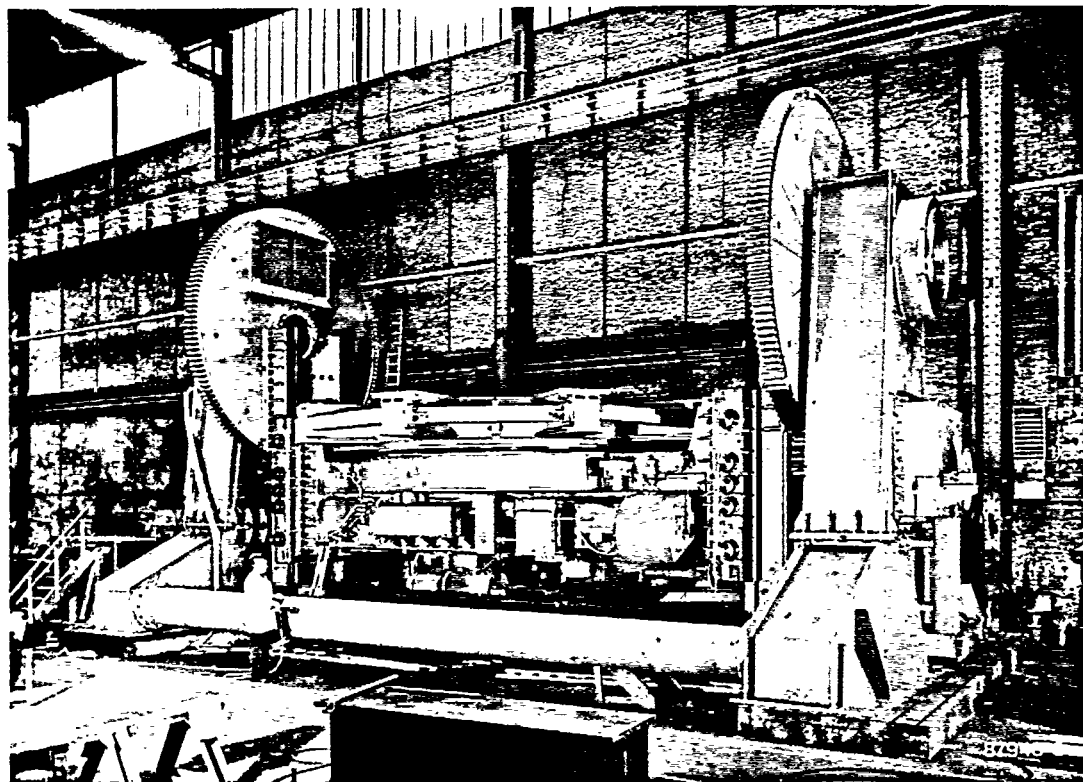

ROTARY POSITIONER WITH A TILTING TABLE WITHIN 360°

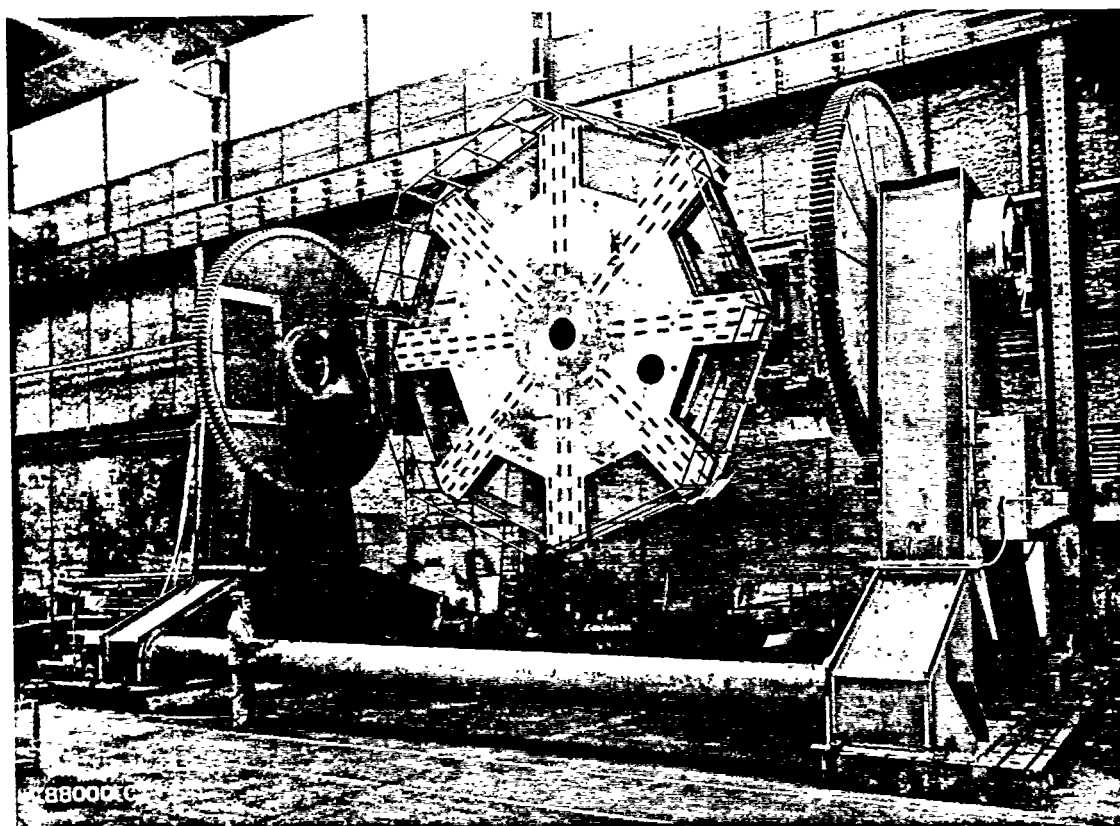

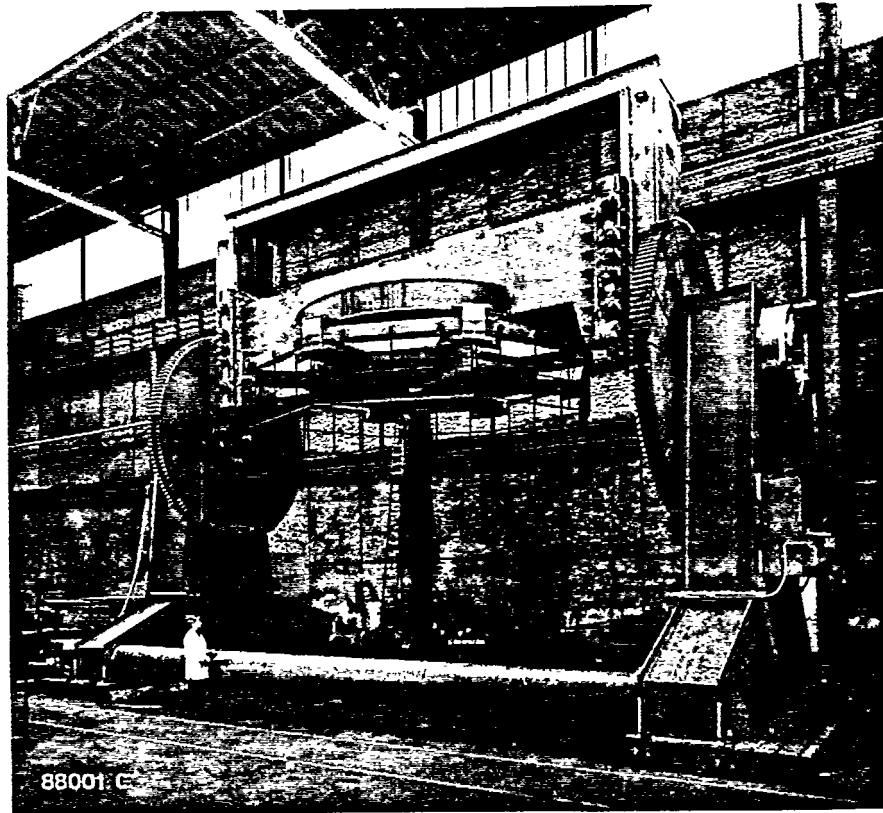

ROTARY POSITIONER WITH A TILTING TABLE WITHIN 360°

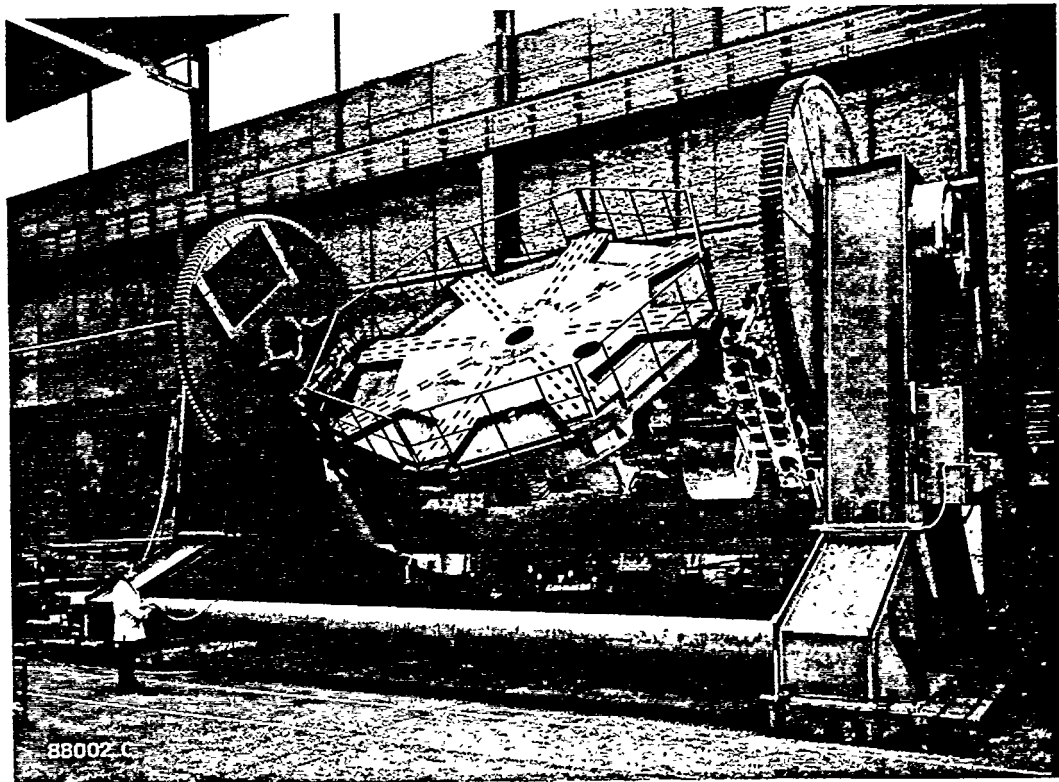

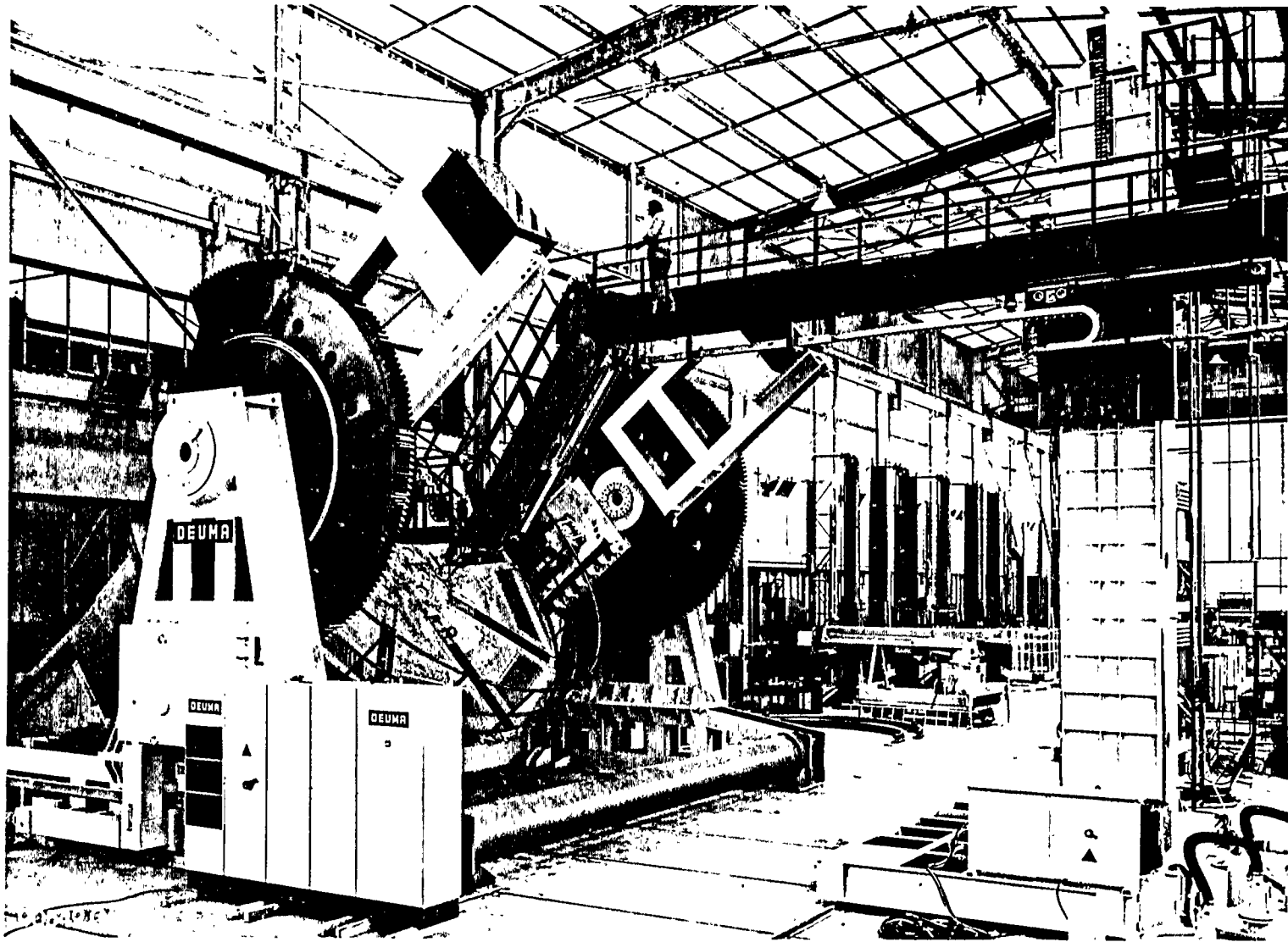

POSITIONER AND BOOM BUILT WITH PROGRAMMABLE CONTROL [PC]

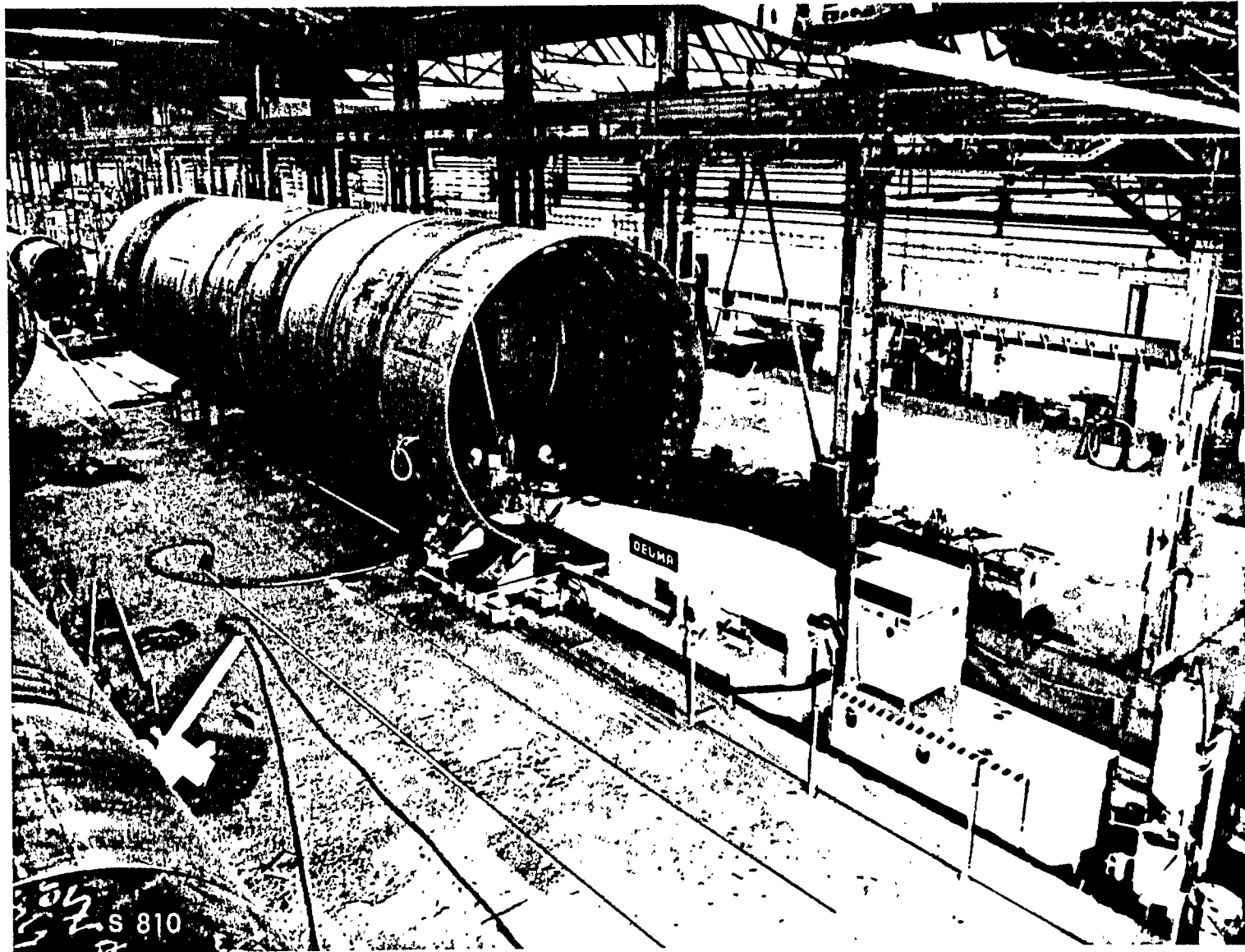

PRESSURE VESSEL SHOP CROCODILE WITH EXPANDING TURNING ROLL SYSTEM ASSEMBLING SHELL RINGS INTO SHELLS, TACK & CIRC-WELD TO ANY PRACTICAL LENGTH, WEIGHT AND DIAMETER