

D-08  
MASS  
# 0119

## PHASE REPORT

# COPPER-NICKEL Hull Sheathing Study



UNITED STATES DEPARTMENT OF COMMERCE  
Maritime Administration  
Office of Research & Development  
Washington, D.C. 20230

Decembe 31, 1980

# Report Documentation Page

Form Approved  
OMB No. 0704-0188

Public reporting burden for the collection of information is estimated to average 1 hour per response, including the time for reviewing instructions, searching existing data sources, gathering and maintaining the data needed, and completing and reviewing the collection of information. Send comments regarding this burden estimate or any other aspect of this collection of information, including suggestions for reducing this burden, to Washington Headquarters Services, Directorate for Information Operations and Reports, 1215 Jefferson Davis Highway, Suite 1204, Arlington VA 22202-4302. Respondents should be aware that notwithstanding any other provision of law, no person shall be subject to a penalty for failing to comply with a collection of information if it does not display a currently valid OMB control number.

1. REPORT DATE <b>31 DEC 1980</b>		2. REPORT TYPE <b>N/A</b>		3. DATES COVERED <b>-</b>	
4. TITLE AND SUBTITLE <b>Copper-Nickel Hull Sheathing Study</b>				5a. CONTRACT NUMBER	
				5b. GRANT NUMBER	
				5c. PROGRAM ELEMENT NUMBER	
6. AUTHOR(S)				5d. PROJECT NUMBER	
				5e. TASK NUMBER	
				5f. WORK UNIT NUMBER	
7. PERFORMING ORGANIZATION NAME(S) AND ADDRESS(ES) <b>Naval Surface Warfare Center CD Code 2230 - Design Integration Tools Building 192 Room 128 9500 MacArthur Bldg Bethesda, MD 20817-5700</b>				8. PERFORMING ORGANIZATION REPORT NUMBER	
9. SPONSORING/MONITORING AGENCY NAME(S) AND ADDRESS(ES)				10. SPONSOR/MONITOR'S ACRONYM(S)	
				11. SPONSOR/MONITOR'S REPORT NUMBER(S)	
12. DISTRIBUTION/AVAILABILITY STATEMENT <b>Approved for public release, distribution unlimited</b>					
13. SUPPLEMENTARY NOTES					
14. ABSTRACT					
15. SUBJECT TERMS					
16. SECURITY CLASSIFICATION OF:			17. LIMITATION OF ABSTRACT <b>SAR</b>	18. NUMBER OF PAGES <b>100</b>	19a. NAME OF RESPONSIBLE PERSON
a. REPORT <b>unclassified</b>	b. ABSTRACT <b>unclassified</b>	c. THIS PAGE <b>unclassified</b>			

REPORT DOCUMENTATION PAGE	1. REPORT NO. MA-RD-930-81025	2.	3. Recipient's Accession No.
4. Title and Subtitle  Copper-Nickel Hull Sheathing Study		5. Report Date December, 1980	
7. Author(s) Dr. L. W. Sandor		6.	
9. Performing Organization Name and Address  Sun Ship, Inc.  Chester, PA. 19013		8. Performing Organization Rept. No.	
12. Sponsoring Organization Name and Address  U.S. Department of Commerce Maritime Administration Office of Commercial Development 14th & E Sts., N.W., Washington, DC 20230		10. Project/Task/Work Unit No.  18411	
15. Supplementary Notes		11. Contract(C) or Grant(G) No. (c)DO-A01-78-3091 (G)	
16. Abstract (Limit: 200 words)		13. Type of Report & Period Covered Phase 1978-1980	

## 16. Abstract (Limit: 200 words)

Fuel consumption of ships is related to hull roughness. The increasing high cost of fuel is the driving force behind the efforts that are expended in looking for methods, which would reduce hull roughness and would maintain a smooth hull surface profile during the designed life of a ship. One such desirable method involves the use of copper-nickel

This study examined a number of methodologies for applying Cu/Ni in sheet form. The welding of Cu/Ni clad steel was also evaluated in a shipyard environment. The cost differential between Cu/Ni sheathed and conventional painted hulls was determined for a large container ship.

The economic analysis was based on 1980 cost figures and a specific application method of Cu/Ni hull sheathing. The results were 33.5% for the effective discounted cash rate of return and 4.2 years for the zero-interest breakeven point--against an initial incremental investment of \$3.4 million using 46% tax rate.

## 17. Document Analysis and Descriptors

Copper-Nickel sheathing, welding, adhesives, cladding, antifouling, erosion-corrosion resistance, economic analysis, fuel, maintenance, speed, power.

## b. Identifiers/Open Ended Terms

## c. COSATI Field/Group

8. Availability Statement **Approved for Release**

National Technical Information Service  
Springfield, Va. 22161

19. Security Class (This Report)

21. No. of Pages

20. Security Class (This Page)

-95

22. Price

ANSI Z39.18

See Instructions on Reverse

PHASE REPORT

# **COPPER-NICKEL Hull Sheathing Study**

by  
Dr. Leslie W. Samdor



UNITED STATES DEPARTMENT OF COMMERCE  
Maritime Administration  
Office of Research & Development  
Washington, D.C. 20230



**SUN SHIP, INC.**  
Chester, Pa. 19013

## CONTENTS

	Pages
I. INTRODUCTION	
II. PROCEDURE	5
III.A. WELDING OF CU/NI SHEATHS TO STEEL PLATES	7
(a) Gas Metal-Arc Welding	7
(b) Shielded Metal-Arc Welding	10
Summary of Welding Cu/Ni Sheaths	11
(a) GMAW	11
(b) SMAW	11
III.B. WELDING OF CU/NI CLAD STEEL PLATES	13
(a) Shielded Metal-Arc Welding	13
Summary of Clad Experiments	15
III.C. COMBINATION OF TWO SMA ELECTRODE SIZES	15
IV. ADHESIVES	17
V. STRUCTURAL INTEGRITY ASSESSMENTS	20
(a) Metallurgical Investigations	20
(b) Mechanical Testing	21
VI. ECONOMICS	23
VII. SUPPORT PROGRAMS	27
VIII. CONCLUSION	29
(A) Sheathing	29
(B) Cladding	31
IX. RECOMMENDATION	32
X. ACKNOWLEDGEMENT	33
REFERENCES	34
APPENDIX I.	36
Fig. 1-21	37-57
TABLE I-V	58-63
PHOTOGRAPHS	64
Fig. 22-38	65-81
APPENDIX II.	82
Technical Data and Information on the Respective Adhesives	83-90
APPENDIX III.	
Parts of Mr. S. M. Fisher's Report	92-96

## 1. INTRODUCTION

The single most expensive aspect of operating a ship today is the cost of fuel (1). Therefore, it has increasingly become more compelling for ship owner/operators to search for ways and means to reduce fuel consumption. Effective energy-saving measures, in the context of the overall U. S. ship-building industry, would have a significant and favorable impact on the balance of payment of the Administration as well.

The fuel consumption of a conventional painted ship is strongly dependent upon the hull surface roughness. In this regard the most important factors include the roughness of the paint, roughness induced by marine biofouling and erosion-corrosion of the steel plate. Methods which could eliminate or reduce such roughness phenomena would have highly desirable benefits in several areas of ship operations. There are in the normal state of the art quite a few known methodologies for controlling - to varying degrees of success to be sure - the deterioration of materials or structures exposed to marine environments. They may be classified as barriers, inhibitors, impregnants, inert materials, temperature and velocity controls. A common barrier type approach for ship hulls is the anti fouling coating. These coatings owe their enhanced biofouling resistance to the presence of cuprous oxide and tributyl tin oxide. Many copper-base alloys exhibit varying degrees of resistance to biofouling (2). Copper alloy CA-706 is reported to have excellent erosion-corrosion as well as antifouling properties proven by several engineering structures used in different environments (2-10).

The first application, as a hull material, of CA-706 alloy dates back to 1939 when a yacht was built for Revere Copper (11). The composition of CA-706 is given in Table 1. There was little activity in using copper-nickel (CA-706) for hulls until the 1960's when the hull of a private sailboat was

fabricated from this material. Unfortunately, no engineering records are available on these copper-nickel boats. In the early 1970's, the American Copper Development Association, Inc. undertook the construction of several fishing boats to study the technology and the economics associated with the manufacture of both solid and clad Cu/Ni boat hulls. The results of these shrimp boats used in tropical waters were reported by Manzollilo (6), Thiele (10), Prager (12, 13, 15) and Minard (14).

Tests by Sun Ship, Inc. involving the sheathing of a rudder and the placing of insulated Cu/Ni panels on large, commercial surface vessels were carried out in the late 1970's (4, 5, 8, 16). These and subsequent laboratory experiments indicated the feasibility of the Cu/Ni hull sheathing concept. What was still lacking, however, was the determination of the most optimum application method of Cu/Ni and its in-service evaluation in a technological and economic sense.

The economic advantages of the Cu/Ni concept have long been identified as stemming mostly from fuel savings, decreased dry docking, revenue savings, reduction of propulsion plant, scrap value of copper/nickel alloy and increased profit. There are still other potential areas for savings. The exact magnitude of the total savings depends on the specific scenario of a ship in question. The initial investment associated with a copper/nickel-steel composite hull is a function of the costs of material, labor and fabrication method unique to the alloys involved.

Based on extensive economic and technological assessments of how to build large composite ship hull structures, the two most promising avenues looked to be sheathing and cladding (17-18).

Sheathing may be defined as the use of Cu/Ni alloy sheet which is bonded in situ to steel plates already erected as ship hulls or ship modules. Cladding can be defined as a bimetallic material composed of a carbon steel substrate to which, on one side only, a layer of Cu/Ni alloy is already metallurgically bonded when received for construction.

While prior studies on cladding indicated technological feasibility, it was found to have certain disadvantages relative to the sheathing approach. These drawbacks include higher purchase price, composite plate size limitation, weld contamination possibility and usage limited to new construction. Sheathing, on the other hand, is much more versatile in that it lends itself to retrofit new construction, and easier automation. Furthermore, the initial purchase price of sheathing is considerably lower. Sheathing has the potential of earlier application to the marine industry because it requires no major capital investment for its application.

Even though the emphasis of this program is on the sheathing approach, weld qualification of the clad material under shipyard conditions is also re-examined. Another reason for including the clad material in this study is the possibility of its use in high stress areas of the ship. The criteria for successful application of copper-nickel sheaths are long term durability, acceptable application cost and reconfirmation of satisfactory erosion-corrosion performance using a large commercial surface vessel in actual oceangoing environments.

The project was divided into three phases: (1) initial laboratory phase, (2) final laboratory phase, and (3) field phase. The purpose of such an organization was to maximize the data and information flow within the given time frame and budget constraint. This three-phase approach allowed for

statistical re-affirmations of results in going from one phase to another using in each successive phase larger and larger size samples to scale up the experiments gradually.

State-of-the-art application methods considered for this program consisted of 100% peripheral welds, the same in combination with plug welds, or adhesives or resistance spot welds. Thought was given to such concepts as roll-out sheathing, and 100% bonding by different species of polymeric adhesives including a 1/4" epoxy dielectric tape. Moreover, electron-and laser-beam, ultrasonic welding as well as MIG spot welding were included in the overall scope of the Cu/Ni project. During the course of the study the choice was narrowed down to four methodologies of merit for the ensuing Field Phase of this contract.

## II. PROCEDURE

A number of the state of the art application methods were considered for sheathing a steel hull. The list includes the following:

1. 100% peripheral (seam, butt or fillet) weld
2. 100% peripheral weld plus plug (or slot) weld
3. 100% peripheral weld plus different adhesives
4. Ultrasonic welding.

In the initial laboratory phase small Cu/Ni test coupons of 3" x 6" x .10" (76.2 x 152.4 x 2.5 mm) size were used on ABS Grade B steel samples of 10" x 16" x .75" (254 x 406.4 x 19 mm) dimension. The size of the clad sample was 4" x 12" x 1" (101.6 x 304.8 x 25.4 mm). In the final laboratory phase only the sheathing method was tested using sample sizes of 3' x 5' x .10' (91.44 cm x 152.4 cm x 2.5 mm) for the Cu/Ni and 7' x 12' x .4375" (213.4 cm x 365.8 cm x 11.1 mm) for the steel plate.

On every steel sample three Cu/Ni coupons or panels were welded and/or adhesive bonded to duplicate the sheathing arrangement on the ship hull, A schematic drawing of the arrangement is shown in Figure 1. The graphical illustration of the clad sample and the sequence of its welding can be seen in Figure 2.

Of the fusion arc welding processes, the shielded metal-arc and the gas metal-arc processes were chosen. Both weld methods were evaluated in all welding positions. The respective weld data can be found in Table II.

The polymeric adhesives recommended by the respective manufacturers were first subjected to "screen" testing in order to select the two most promising species for further shipyard evaluation. The screen methods consisted of peel, tensile shear, impact and bend testing of small coupons

of copper/nickel bonded to steel without any welding. Different test coupon sizes were used, namely, 1" x 5" (or 15") x .10" and 1" x 5" (or 15") x .03" (or .375") for the Cu/Ni and steel, respectively. The Bostik and 3M products were subsequently investigated in shipyard environments and under the influence of welding. The sample sizes of the in-shipyard adhesive-weld experiments were 3" x 6" x .10" (76.2 x 152.4 x 2.7 mm) for the copper/nickel and 5" x 8" x .375" (127.0 x 203.2 x 9.5 mm) for the steel plate.

### III. A. WELDING OF CU/NI SHEATHS TO STEEL PLATES

#### (a) Gas Metal-Arc Welding

The increase in weld productivity is an important factor in safeguarding the future of any shipyard. With that in mind, the gas metal-arc welding (MIG) was first evaluated for welding Cu/Ni-Fe/C dissimilar materials. In addition, the shielded metal-arc process (SMA) was also a part of this program. In welding components of large vessels, the welding process should preferably have a capability for welding in all positions. The smaller the size of the molten puddle, especially with bare metal solid filler metals in out-of-positions, the easier for the welder to control. Therefore, the smallest available wire size of .035" (.89 mm) was selected. The list of parameters investigated with MIG is given below.

- ° Gap sizes of .125", .250", .375" and .500" (3.2-12.7 mm) between adjacent Cu/Ni panels,
- ° Low, normal and high weld heat input,
- ° Typical rust on steel, clean to "white metal" and shotblast-and-preproduction zinc rich primed steel surface,
- ° Flat, horizontal, vertical down and overhead weld positions,
- ° Peripheral weld,
- ° Peripheral weld plus round plug and slot weld,
- ° Argon/Helium (.75/25%) and pure Argon (100%) shielding gas.

Factors held constant were as follows:

- ° Monel 60 (AWS A5.14 Class ER NiCu-7) filler metal,
- ° Weld wire diameter .035",
- ° Shielding gas flow rate @ 12.5 ft<sup>3</sup>/hr,
- ° Direct current reverse polarity ( D C R P ) .

Penetration of the weld into the steel substrate was found to be a function of the amount of rust present on the steel, the size (width) of the gap between adjacent Cu/Ni sheaths and the weld heat input, all else being constant. Figure 3 shows the gap size plotted against the width of weld penetration. The graph also indicates the percentile lack of penetration (LOP).

The magnitude of the crack-like discontinuity (CLD) present at the intersection of the copper/nickel-steel-Monel weld is very much influenced by:

1. Gap size
2. Steel surface condition with respect to rust
3. Fit up of Cu/Ni on Fe/C

From the standpoint of structural integrity and quality, it is desirable to have an excellent weld penetration into the steel plate and the copper/nickel sheet. Imposition of hydrodynamic conditions on hull weldments provide a preference for a weld profile flush with the Cu/Ni sheets. The removal of rust, good fit up and optimized gap size aid the weld penetration.

In the liquid state, the surface tension of Monel 60 weld wire and the inferior wetting conditions of the weld joint made it impossible to obtain a smooth, flush. weld profile. In the flat, the horizontal and the overhead positions the weld had a very pronounced reinforcement and in the vertical down position a concave configuration. Single pass welds in small gaps produced too much LOP and unsatisfactory weld shape in all weld positions regardless of weld heat input. The morphology of a round plug weld is rather cumbersome from the welder's point of view; hence, the configuration of a slot is the preferred way to do short welds (see Figure 4). As with peripheral welds, the same criteria on penetration and profile apply to slot as well as to plug welds.

While some sporadic spatter and minute surface porosity occurred with MIG welding, their occasional presence is not viewed with concern. In terms of minimal LOP, the optimum gap size seems to be .5" (12.7 mm). The ideal sequence of weld passes to fill such a gap (weld joint) is to perform two fillet welds - one on each side of the joint - and one fill-in pass. This weld practice hereinafter shall be referred to as "2f+f-i" and is highly advisable in all weld positions. The fillet welds are to ensure adequate "nailing" of the copper/nickel panels to the underlaying steel hull plate. The fill-in pass serves primarily as a "leakproof" and profile satisfying weld pass. Figure 5 shows the "2f+f-i" weld sequences, graphically.

The role of interpass temperature (or substrate temperature) with Monel 60 MIG welding is extremely important. In overhead weld position, the most critical. No acceptable weld could be made in OH position irrespective of heat setting (be it Low, Normal or High Heat Input), travel speed and substrate temperature. Of the other three weld positions, the flat position yielded the best weld, naturally, though the reinforcement was still excessive. The preproduction zinc rich primer coating had no detrimental effects upon the weld quality.

In research of the causes of the formation of CLD, the ensuring parameters were found to play a significant part,

- ° Inferior fit up
- ° Heavy rust
- ° Low weld heat input
- ° Narrow gap
- ° Long arc length
- ° Incorrect electrode angle

(b) Shielded Metal-Arc Welding

Perhaps the most widely recognized merit of the shielded metal-arc (SMA) welding is that joints which are reachable with an electrode of the proper diameter can be welded in virtually any position. Inwelding hulls of large ships such an attribute has a special significance. The SMA process, on the other hand, has one notable shortcoming; i.e., low productivity, SMA is an intermittent fusion arc joining method.

The approach to SMA welding of Cu/Ni-Fe/C composites was similar to that used in MIG. The parameters investigated included:

- ° Gap sizes: .125", .250", .375", .500", .625"
- ° Interpass temperature
- ° All weld positions
- ° Peripheral weld
- ° Peripheral weld + round plug or slot weld
- ° Rusted steel
- ° Rust-free steel

Methods of rust removal from small test coupons and large steel plates consisted of hand grinding and shotblasting in the regular production shot-blast facility, respectively. Monel 190 (ANS A5.11 Class ENiCu-2) electrode size 3/32" (2.38 mm) and DCRP were used in most SMA experiments except for a few SMA tests involving combinations of two electrode sizes (See Section III.C.), The "2f+f-i" weld sequence was utilized as in the MIG evaluation tests regarding peripheral welds as well as plug or slot welds.

To obtain comparable overall weld quality and penetration in particular in plug or slot welds, the weld current had to be raised 5 amps higher than that of corresponding peripheral weld position. The explanation for the

higher slot weld current requirement can be traced to thermodynamic and geometric considerations. Requirements for rust removal, mitigation of CLD are governed by the same considerations elucidated in conjunction with MIG welding. Again, the presence of preproduction zinc-rich primer posed no problem. An important point to note is that each specific weld position has its unique set of requirements for obtaining optimum results. Table IV portrays these requirements.

To curtail the use of SMA in hopes of improving weld productivity, attempts were made to utilize SMA for the two fillet welds and MIG for the fill-in pass using 75/25 Ar-He mixture at 12.5 ft<sup>3</sup>/hr flow rate. Anew, the fillet welds were excellent, but the fill-in pass had the same drawbacks expounded earlier in the report.

#### Summary of Welding Cu/Ni Sheaths

##### (a) GMAW:

The gas metal-arc welding method involving .035" solid wire filler metal of Monel 60 did not satisfy the weld requirements set for a Cu/Ni sheathed hull in the out-of-positions, particularly in the overhead weld position. In the flat position the weld quality was acceptable except for a very high reinforcement. Single pass welds in gap sizes smaller than 3/8" resulted in too much LOP and undesirable weld profiles in all weld positions irrespective of heat input. The preferred weld sequence practice is the "2f+f-i". A gap size of 1/2" was found to give minimal LOP. The interpass temperature in OH and VD positions should not exceed 200° F and 350° F, respectively.

##### (b) SMAW

The shielded metal-arc welding process using Monel 190 size 3/32" electrode with DCRP gave excellent results in all weld positions. The preferred gap size is 3/8" in all but the VU position, which requires 5/8".

Like GMAW, the ideal pattern of weld passes consists of "2f+f-i".

The magnitude of the crack-like discontinuity is a strong function of the fit up between copper/nickel sheath and the steel plate, the gap size and the amount of rust on the steel surface. A combination of SMA and GMA welding in the out-of-positions was deemed unsatisfactory because of the solid Monel 60 wire electrode problems already mentioned.

### III. B. WELDING OF CU/NI CLAD STEEL PLATES

#### (a) Shielded Metal-Arc Welding

The main purpose of this work was to re-establish in a shipyard environment the viability of the welding method developed elsewhere (12-15, 19). While the overall economics of the sheathing technique are far more attractive than that of the cladding method, the latter was included in this program because of its probable need in hull locations such as the propeller area, the bulbous bow or the rudder.

The practice of welding Cu/Ni clad steel in essence consists of a two-step approach. First, the steel side root pass is welded by E6010, size 5/32" (3.97 mm), DCRP. The remaining steel joint is filled in by E6027, size 3/16" (4.76 mm), DCRP. The joint preparation on the steel side involved single "V" with 60° included angle and 1/16"-1/4" (1.59-6.35 mm) land. The purpose of the land is to prevent dilution. The root opening ranged from zero (0) to 1/8" (3.18 mm) in increments of 1/16" (1.59 mm). The steel thickness was .93" (23.8 mm). Flat, horizontal, vertical up and overhead weld positions were examined.

In welding the clad side, two different joint preparation procedures were evaluated.

- (1) Groove or joint preparation by means of air carbon-arc with carbon rod diameters of 3/16" (4.76 mm) and 5/16" (7.94 mm) so as to determine the minimum groove size necessary to insure acceptable weld quality using Monel 190, size 3/32" (2.38 mm) electrode. Backgouging was extended into the root pass of the steel side welds to remove entrapped slag inclusions. The air carbon-arc groove should be adequately "feathered" to help eliminate arc instability, excessive spatter and slag

entrapment. In the event the groove turns out to be larger than required, the Monel electrode size should be changed to 1/8" (3.18 mm) to decrease welding time.

- (2) Backstripping of the Cu/Ni cladding up to 3/8" (9.53 mm) on both sides of the joint. Backgouging of the steel root pass and welding were along the lines outlined above. The 1/8" (3.18 mm) root opening is preferred to the tight root (or nose), especially with the backstripping method. The root opening of this magnitude requires less time to backgouge, causes less slag entrapment and provides an easier access to the making of the steel side root pass. The welding current for E6010, size 3/16" and E6027, size 5/32" was 130 amps, DCRP. The clad side welding current ranged from 85-90 amps, DCRP. Although a backstripping of 3/8" (9.53 mm) on both sides of the joint was investigated, 1/4" (6.35 mm) should prove to be sufficient so as to conserve filler metal usage.

It is advisable to keep in mind that from a standpoint of accuracy in working out the cost of welding, the number of passes in the various positions may not necessarily be equal. For instance, the extent of weld penetration from the steel side in the overhead and vertical up position is less than in flat or horizontal positions, everything else being constant. The reduced penetration creates the necessity for an increase in backgouging from the clad side, in the context of a production environment, this aspect of Cu/Ni clad steel welding should be treated as a variable - and as such, it requires attention and control because of the high cost of Monel 190 relative to E6010 and E6027. The method of welding clad steel is shown schematically in Figure 2.

### Summary of Clad Experiments

Irrespective of weld positions, the ideal root opening was found to be 1/8". To prevent diffusion of copper into the steel a land (or nose) of 1/4" (1/8" on the Cu/Ni and 1/8" on the Fe/C side) is needed, particularly with the air carbon-arc groove approach. The criticality of the 1/4" land is negated in the backstripping methodology. Which method is more desirable from an economic point of view is now unknown.

The-geometry of the backgouged groove is important. The groove should be sufficiently open to minimize arc instability, slag entrapment and to provide accessibility. Should the dictates of hydrodynamics be a smooth weld profile, the reinforcement would then have to be removed by an appropriate method.

### III.C. COMBINATION OF TWO SMA ELECTRODE SIZES

In order to attain the smoothest weld profile with a minimal number of passes for a given gap (joint) size, experiments were run with two different Monel 190 electrodes, namely 3/32" for "2f" and 1/8" for "f-i". It might be worthwhile to remember that the fill-in pass(es) is a strong function of fit up of hull composites. The nature of the fit up problem may be rooted in misalignment of subassemblies (or modules) movements of steel plate and/or copper/nickel panel during welding, plate or sheath disregistry due to errors in cutting, and plating unfairness.

The principal-factors of this series of experiments may be found in Table V. Four Cu/Ni test coupons (3" x 6" x .10") were welded to shotblast and preproduction primed steel samples. The results showed excellent weld soundness and the smoothest weld profile obtained thus far in all but the overhead position. The 1/8" electrode in OH position involving .10" deep joint simply gives too much puddle to control satisfactorily. Consequently,

the surface appearance of the fill-in pass was rather rough. Hence, the 1/8" size Monel 190 electrode in OH position welding is not recommended.

#### IV. ADHESIVES

The large-scale industrial application of adhesive bonding is rooted in the aerospace industry. The attributes of the aerospace industry include cleanliness, controllable work environment, relatively small components made mostly of aluminum alloys and plastics bonded together in autoclaves. The in-service environment of the end product is air or out of space. The elements as well as the requirements of shipbuilding and the field environment of the finished product are altogether different. In consequence, a direct acceptance of aerospace-type adhesives may not be viable for shipbuilding purposes. The market has been glutted with polymeric adhesives of one chemical formulation or another. A broad classification of them might be epoxy, acrylic, tar-base and nitrile-base, just to name a few. Adhesives may come as one-part, two-part, premix, in-flow, thin film, thick film, tape-backed and so on.

Technical experts from 3M, Bostik, American Cyanamid, Armstrong and Adhesive Engineering were called in for consultation with regards to the principal aims of using adhesives in the current project. The basic requirements set were to obtain an ambient temperature, slow-cure and preferably non-brittle type adhesive. In addition, the candidate adhesive ought not to be very sensitive to clean surfaces and/or work environments as well as to applied pressure to bring about an acceptable bond strength. The in-service performance requisites were predicated upon resistance to sea water, fatigue endurance and immunity from the toxic nature of one of the adherands, namely the Cu/Ni sheath. Toxic environments have been known to cause delamination of certain composite structures.

Adhesive manufacturers undertook a feasibility study and thereafter submitted the respective candidate products. Only four manufacturers out of the original five succeeded in offering adhesives. Specific technical data and adhesive products descriptions are given in Appendix II.

A "screening" test program was set up and awarded to DL Laboratories for an independent evaluation to allow performance ranking. Peel, tensile shear, impact and bend tests were selected because of simplicity and a certain degree of simulation of loading conditions imposed on hulls of ocean-going vessels. Funding was provided for by the Copper Development Association, Inc. (CDA). The results of the tests can be seen in Table III. Figures 6-9 show the test data plotted so as to facilitate comprehension.

Bostik M-890 and 3M XB-5354 were considered to yield an overall best performance on grounds of anticipated needs in a composite ship hull. Admittedly, this assessment comes from limited population of data generated by small test coupons which may not fully reflect the behavior of large structures. Moreover, the final laboratory performance ranking was to some extent judged on the basis of bend and impact test data. The rationale was that a sea-fairing ship undergoes a great deal of bending and impact stressing due to wave motion, floating objects and dry docking events.

M-890 and XB-5354 were re-examined in the shipyard primarily to investigate the effect on weld quality and bond strength, of weld heat input. One of the initial concerns was the formation of porosity in the weld arising from transformation of the adhesives to a gaseous form. The second concern had to do with debonding (delamination) due to differences in thermal properties of the respective adherands (Cu/Ni and Fe/C) inducing undesirable residual stresses. So, the approach was to examine different "clearance"

distances. "Clearance" refers to an adhesive-free zone between the edge of the weld joint and the borderline of the applied adhesive. Three clearance distances were investigated: 0.0", 0.5" (12.7 mm) and 1.0" (25.4 mm). Zero clearance gave a completely unacceptable weld. In point of fact, the welding arc was so unstable as to make a continuous welding impossible. Figure 10 shows a photograph of these welds.

A continuous welding was possible with the 0.5" clearance samples. However, the so-called "non-stop" peripheral weld practice using 3" x 6" x .10" Cu/Ni specimens still produced a large pore in the crater upon closing the weld around the periphery of the Cu/Ni sheath (see Figure 11). The residual weld heat input in small samples of this size caused outgassing of the adhesive. The internal gas pressure was high enough to blow through the closing weld puddle. The 0.5" clearance test was repeated by introducing one change in the experiment. The sample was allowed to cool to room temperature with a 1" unwelded "vent" left in the peripheral fillet weld. This permitted the gas to escape from the bonded Cu/Ni-Fe/C interface. Then, the 1" vent was fillet welded successfully. No trace of porosity in the so-called "seal weld" was noted (see Figure 12). The composite bond weld samples with the 1" clearance distance under continuous weld practice conditions gave excellent results as shown in Figure 13. The Bostik bond weld sample with 0.5" clearance showing a sound weld can be seen in Figure 14.

## V. STRUCTURAL INTEGRITY ASSESSMENTS

The mechanical and metallurgical characterization of copper/nickel-steel composite material is essential to the prediction of its behavior in service. Today, a limited applied engineering knowledge exists about the elastic and plastic behavior of this composite assessed under either laboratory or field conditions. This is particularly true for hull applications of large surface vessels.

In recognizing the fact that there are various methods to produce Cu/Ni-Fe/C composite hulls, it is important that the mechano-metallurgical studies do get focused on the most promising method both economically and technologically in order to hold the research costs involved to a minimum. Time and budget constraints of the present contract permitted only a brief scrutiny in such studies.

A subcontract was awarded to West Virginia Institute of Technology to examine the metallurgical nature and evaluate the mechanical properties of composite weldments. The subcontract was so planned as to concentrate on hull structural design needs. The salient points of the subcontract work will only be mentioned in this report. For a complete detail, Reference 20 should be consulted.

### (a) Metallurgical Investigations

Included in this scope of activity were-microstructure examinations and microhardness measurements of the steel plate, the copper/nickel sheet, the Monel 190 weld and the HAZ on the steel side and on the copper/nickel side.

The base steel had a ferrite-pearlite microstructure characteristic of a carbon-manganese steel (ABS Grade B). In going through the respective heat affected zones the microstructure and the grain sizes changed under the

influence of the weld heat input due to a temperature gradient. At the weld metal-steel interface, there was some evidence of copper "fingers" running down the austenite grain boundaries. Microcracks and crack-like discontinuities were noted in this region on occasion. The copper/nickel HAZ showed a fine dendritic microstructure changing to selective melting along the grain boundaries of the base copper/nickel. The Monel 190 weld displayed a coarse dendritic microstructure. The base copper/nickel exhibited a recrystallized (annealed) grain structure with evidence of twinning and alloy segregation.

As expected, hardness measurements traversing the base metals, the HAZ's and the weld illustrated a change in hardness values. The relative hardness values are indicative of the changes in the microstructure, which is demonstrated in the photomicrographs (See Reference 20).

(b) Mechanical Testing

To gain some "insight into the behavior of Cu/Ni-Fe/C composite weldments under static and dynamic loading conditions a few small samples were tested at ambient temperature. The static tests involved tensile testing of the base copper/nickel and lap shear testing of butt and slot welds. The dynamic tests consisted of low-cycle fatigue of the tension-compression (alternating stress) and pulsating (tension-tension) mode.

The mechanical properties of the base copper/nickel agreed with published values for the annealed ("0" temper) condition. Due to geometric effects (stress concentrations) and residual stresses, the ultimate tensile strength of the copper/nickel at the weld is less than that of the non-welded Cu/Ni, but is above the yield strength of the base Cu/Ni. The lap shear stress of both the butt and the slot welds is greater than the ultimate tensile strength of the base Cu/Ni alloy. In other words, failure under overload conditions

should normally occur in the Cu/Ni HAZ, as in fact it did. Fatigue failure also occurred in the Cu/Ni HAZ starting at the crack-like discontinuity (CLD). CLD is formed by the inherent geometry of the steel substrate, the copper/nickel panel and the Monel 190 weld joining the dissimilar metals together. A stress concentration is always inherent in such configurations. One fatigue test sample failed in the base steel at some gross weld discontinuity. This suggests the need to examine the significance of weld discontinuities leading to the establishment of weld acceptance standards.

Both types of polymeric adhesives used in conjunction with fusion-arc welding gave rise to a substantial improvement in the fatigue life of the composite weldments. The reason lies in stress concentration reduction at the copper/nickel-steel-Monel weld interface. Expressed differently, the presence of an adhesive gives rise to a redistribution of the imposed stresses: residual and applied.

VI. ECONOMICS

Like everything else, the ultimate viability of the Cu/Ni ship hull sheathing as a concept is measured by its economics. On one side of the economic balance is the initial investment (see Figure 15), while fuel and maintenance savings are on the other (Figure 16). The elements of savings may conveniently be categorized as major, minor and miscellaneous. The major elements of savings for ship owner/operators come from lower fuel consumption, decreased dry docking, reduction in shaft horsepower requirements and propulsion plant size.

In the past, the cost of fuel, dry dock, and other attendant expenses were relatively low. Hence, the cost differential between conventional, painted steel hull and clad or sheathed steel hull mitigated against the application of copper/nickel.

In the 1970's, notably in 1973 and 1979, the price of fuel oil suddenly escalated so much that today the single biggest expense in operating large ships is the fuel. Reportedly, fifty percent of the total cash flow for ship owner/operators is associated with fuel consumption. This and the heightened inflation worldwide hurled the Cu/Ni concept into prominence as an attractive economic counter-measure.

Included in the minor savings category are increased profit, reduction in revenue losses and scrap value of Cu/Ni at the end of the useful life of a ship. A list of miscellaneous savings considerations may consist of larger cargo capacity arising from a reduction in propulsion plant size, and an increase in ship speed due to a smoother hull surface.

In naval deployment or in a general strategic sense this increased ship speed and antifouling nature of the base copper/nickel alloy merit special attention.

It is fair to state that a precise economic assessment and forecast can best be approached if the exercise of economic modelling is tailored to a specific ship scenario. So, our economic analysis took the approach of selecting a container ship with its engineering specifics, sea-going environments and assumed annual operating days as shown in Figures 17 and 18.

The initial investment of Cu/Ni sheathing was based on modular construction using a combination of SMA peripheral and slot welding attachment methods and a 10% profit. This approach gave rise to an estimated cost differential between conventional coating and sheathing of \$3.4 million. This incremental investment is recoverable primarily via a decrease in fuel consumption arising from the inherently smoother Cu/Ni panels. Further conservative assumptions included 2 roils for the roughness of sheaths remaining constant and precluding biofouling for the life of the sheathed vessel. A conventional painted steel hull has an initial roughness of about 5 roils MAA (Mean Apparent Amplitude). With a typical hull maintenance of sand brushing and recoating on a biennial schedule, the hull surface continues to degrade with time at an assumed rate of 1 mil per year. In addition, fouling has to be reckoned with so far as conventional painted steel hulls are concerned. For that, 1 mil of roughness per year was used in the economic calculations. Both the conventional and the composite ship were taken to operate at the same speed over the 20 year assumed operational life of the respective ships.

Several authors (21-25) studied the effect of hull roughness on changes in power requirements. A plot of increasing power requirement as a function

of years in service is given in Figure 19. An empirical relationship between increasing shaft horsepower and hull roughness differential between a painted hull and sheathed hull proposed by Towsin (22) is also shown in Figure 19. The so-called "saw tooth effect" of the power vs years-in-service graph is the result of periodic hull cleaning of conventional painted steel hulls.

The 1980 cost of bunker "C" fuel was taken at \$21.00 per barrel representative of U.S. oil price. It is worth pointing out that the international price of crude is substantially higher than that of domestic oil (\$32-35/bbl as of June 1980). Fuel, dry docking and scrap value of Cu/Ni were escalated at an annual rate of 10% over the life of the Cu/Ni sheathed vessel. Some analysts have viewed the 10% escalator as conservative, notably in the light of projected price rises in crude over the next ten years (1980's). The computer input data for the General Electric discounted cash flow computer program (CAFTX \$) are illustrated in Figure 20. A tax rate of 46% is recognized in the G.E. program.

For an effective discounted cash rate of return and zero-interest breakeven point, 33.45% and 4.22 years after the start of ship construction (i.e., 1 year construction + 20 year ship life = 21 years) were obtained, respectively.

There are several additional benefits that may be derived from Cu/Ni sheathed ships. While present U.S. Coast Guard regulations require biennial inspection for such components as machinery and hull inspections, these inspections could be accomplished in situ without dry docking. The present economic model assigns no credit to the real possibility for an appreciably longer useful life for the Cu/Ni sheathed ships over their conventional counterparts. As for the Cu/Ni clad steel, the high material cost still

negates its application for large ship hulls in spite of the already high crude oil price of 1980.

## VII. SUPPORT PROGRAMS

All the scientific, technological and economic needs or questions cannot possibly be answered in a most optimal and refined fashion in this current project. Therefore, a number of support programs were initiated and have been guided towards placing the Cu/Ni ship hull sheathing concept at large on the highest level of academic footing and engineering understanding. The funding of these support programs is of multiple source. The International Copper Research Association, Inc. (INCRA), New York City, provides the wherewithal for a Ph.D. program entitled "The Structural Integrity of Copper/Nickel-Steel Welds" (a three year program). Within the framework of this dissertation a wide range of mechanical loading and welding schemes and models of prototype plates will be examined. One or two Master of Science theses are about to commence to assess the significance of weld discontinuities and the overall quality control aspects of composite weldments. The M.S. program will aim at establishing weld acceptance standards based on the Paris' fatigue crack growth Law:

$$\frac{da}{dN} = C(\Delta K)^m$$

where:

$\frac{da}{dN}$  = the rate of propagation of a fatigue crack per cycle

C,m = constants

$\Delta K$  = the range of stress intensity factor at the crack tip

The M.S. Program will be funded jointly by INCRA and the U. S. Maritime Administration. The post-graduate programs will take place at The Virginia Polytechnic Institute and State University, Blacksburg, VA.

Several studies sponsored by INCRA and/or CDA (Copper Development Association, Inc., Birmingham, Michigan) investigated the feasibility of alternative cladding methods or welding processes with regards to cost, processing difficulties, mechanical and metallurgical properties. The welding processes examined include electron-, laser-beam, electrical resistance spot, ultrasonic and MIG spot welding. The conventional UW method consists of an envil and an ultrasonically vibrated electrode. The workplaces to be welded are placed on the envil serving as a pressure base. Welding of the workplaces occur by the combined action of an applied load and high frequency friction. Weld times per spot is about 1.5 seconds. Examples of UW spots are exhibited in Figure 21. Due to size and shape considerations of large surface vessels, the conventional UW unit cannot be used for Cu/Ni hull sheathing. Consequently, it has to be modified so as to enable the welding of Cu/Ni panels to steel hulls of large ships from one side only. In this mode, the steel hull is the envil. By means of electromagnetic forces the UW unit is held and pressed against the hull while welding takes place from one side of the hull only. Sonobond, Inc., West Chester, PA, submitted an unsolicited proposal dealing with hardware development for a one-sided ultrasonic welding (UW) process. INCO, Sterling Forest, NY, has been researching the development of flux-cored Monel weld wire for out-of-position welding purposes.

More recently, an applied research activity examined various species of polymeric adhesives for bonding Cu/Ni sheaths to steel plates. Some of these support programs are short term while others are longer term projects. All have the prime objective of defining of the best Cu/Ni ship hull sheathing application method expressed in technological and economical terms.

## VIII. CONCLUSION

The principal objectives of the Laboratory Phase of Contract No. DO-A01-78-3091 included the determination of the technologically as well as the economically most promising methods, selected from the state-of-the-art, to apply Cu/Ni sheaths to steel hull and the re-investigation of Cu/Ni clad steel welding in a shipyard environment. Research and development activities involving ultrasonic welding, electron-beam and laser-beam welding were also closely followed in order to complement this project.

### A) Sheathing

Copper/Nickel can be welded to commercial ship hull steel satisfactorily in all weld positions by the shielded metal-arc process. The preferred weld pass sequence consists of two fillet welds and fill-in pass(es). This "2f+f-i" weld practice ensures the welding of the Cu/Ni panels to the steel substrate and helps provide a leak-proof weld as well as a flush weld profile. The surface appearance of the weld in terms of profile was best when Monel 190 electrode size 3/32" for "2f" and 1/8" for "f-i" was used in F, H, and VU positions. In the OH position, the 1/8" size electrode was found too large. Therefore, in the OH position, only 3/32" diameter Monel 190 electrode should be used for all passes.

The gas metal-arc welding using Monel 60 size .035" solid wire electrode gave unsatisfactory results notably in out-of-position welds. In F and H positions, the weld had an excessive reinforcement. The weld profile showed too much concavity in VD position, while in OH position no acceptable weld

Could be made continuously due to fluidity problems of the filler metal. The interpass temperature in out-of-position welding with GMAW in particular was found to be extremely important. The maximum interpass temperature in OH and VU should not exceed 200° F and 350° F, respectively. Each weld position has its characteristic weld parameters to yield optimum results.

The presence of preproduction primer coating posed no problem in either SMA or GMA welding of Cu/Ni-Fe/C composite. Slot welding is preferred to round plug welding from the welder's standpoint. Slot welding requires 5 amps higher current than peripheral welds in similar positions.

A combination welding of SMA for "2f" and GMA for "f-i" passes - in hopes of increasing weld productivity - did not produce satisfactory results insofar as the GMA portion of combination welding (i.e., "f-i") is concerned and for reasons already explained above.

As expected, the performance characteristics of the different adhesives varied. The best rating was given to 3M and Bostik based in large measure on the outcome of impact and bend tests, deemed more representative of loading conditions imposed on ships than that caused by either peel or by tensile shear.

The adverse effects of fusion-arc welding upon adhesive bonded Cu/Ni-Fe/C composite manifest" in outgassing and arc instability giving rise to unacceptable weld quality. To obtain sound welds, the adhesive - regardless of type used - must be kept 0.5" minimum from areas of weld.

A brief mechanical characterization of Cu/Ni-Fe/C weldment showed under low cycle loading conditions that fatigue crack propagation would normally occur in the HAZ of Cu/Ni sheath, initiated at an inherent crack-like discontinuity being at the Copper/Nickel - Steel - Monel interface.

An economic analysis of Cu/Ni sheathing of hulls of large commercial ships produced very attractive results. Against an initial incremental

investment of \$3.4 million and using 46% tax rate, the effective discounted cash rate of return and the zero-interest breakeven point were calculated to be 33.5% and 4.2 years, respectively.

B) Cladding

There are two common ways of preparing the weld joint in clad steel:

(1) groove the steel side with 1/16-1/8" land in the steel to prevent dilution, arc-air the groove on the clad side or (2) groove the steel side to the steel-cladding interface and backstrip the cladding. In either case, a 1/8" root opening minimizes slag entrapment and backgouging. The backstripping method alleviates the criticality for the size of the land and further decreases the slag entrapment, dilution and backgouging.

Irrespective of joint preparation methodologies selected, the actual welding sequence of Cu/Ni clad steel is as follows. Weld the steel side with the appropriate steel filler metal first (in our case: E6010 and E6027), backgouge the steel root pass prior to welding the Cu/Ni clad side with Monel 190 filler metal.

**IX. RECOMMENDATION**

The successful conclusion of the Laboratory Phase warrants the start of the Field Phase of this contract. For this purpose, a search for a test ship was undertaken. Offers of a candidate ship for the Field Phase were made by two commercial ship owner/operators.

A proposal for expanding the Field Phase to include instrumentation to monitor the field performance of the Cu/Ni panels, mounted on the test vessel, was recommended by MarAd. To this end, meetings and preliminary tests have been conducted. An agreement on the details of the Field Phase among MarAd, the owner/operator of the test vessel, the instrumentation company and Sun Ship need be worked out.

To complement and support the present Cu/Ni hull sheathing program, it is recommended that studies in the ensuing areas are in order:

- ° mechanical characterization of Cu/Ni-Fe/C composite weldments,
- ° examination of the significance of weld discontinuities, namely, slag and crack-like discontinuity under cyclic loading conditions,
- ° determination of the influence of adhesives on the extension of fatigue life of bondwelded Cu/Ni-Fe/C composite,
- ° development of flux-cored Monel filler metal,
- ° hardware development of one-sided ultrasonic welding,
- ° determination of tip life of the one-sided UW electrode,
- ° evaluation-of MIG spot welding.

x. ACKNOWLEDGEMENT

The author wishes to express his gratitude to the U. S. Maritime Administration for awarding this contract to Sun Ship, Inc. Mr. J. Seelinger, Program Manager, MARAD, deserves special thanks for his constant support for and cooperation with all aspects of the total program. I am grateful to many colleagues, both within and outside of Sun, who have supplied information, data, and financial as well as technical aid in the support programs of this project.

REFERENCES

1. O'Brien, L. J., Congressional Information Bureau, Vol. 84, No. 75, April 17, 1980, p. 11.
2. "Marine Biofouling," INCO, 6M 9-79 5719(5), New York, New York, U.S.A.
3. Thiele, E. W., Jr., "Copper-Nickel Hulls for Longer, Service-Free Life," CDA Technical Report 707/3.
4. Fu, J., "Results of Cu/Ni Erosion-Corrosion Experiments on GREAT LAND and WESTWARD VENTURE," Sun Ship Report, 1977.
5. Biccicchi, R. T., et al, "High Velocity Seawater Experiments with Copper-Nickel Alloys Directed at Ship Hull Applications," Paper No. 236, NACE, Corrosion/79.
6. Manzolillo, J. L., et al, "CA-706 Copper-Nickel Alloy Hulls: The Copper Mariner's Experience and Economics," SNAME No. 3, 1976.
7. "Copper-Nickel Hull Cladding Cuts Maintenance and Fuel Costs," Metal Construction, The Journal of The Welding Institute, Vol. II, No. 4, April, 1979.
8. Biccicchi, R. T., et al, "Hull Experiments on 24 Knot RO/RO Vessels Directed Toward Fuel-Savings Application of Copper-Nickel," SNAME Annual Meeting, Paper No. 9, 1978.
9. "Ships of the Future to Ride on Clad Bottoms," Iron Age, April 28, 1975.
10. Thiele, E. W., Jr., et al, "Fabrication of Copper-Nickel Systems for Antifouling and Maintenance-Free Applications," OTC Paper No. 1960, 1974.
11. Hanson, P., "A Lightweight Durable All-Metal Yacht," SNAME, 1966.
12. Prager, M., et al, "Welding Copper-Nickel Ships," Welding Journal, AWS, Vol. 56, No. 5, May, 1977.
13. Prager, M., et al, "Joining Copper and Copper-Nickel Clad Steels," Welding Journal, AWS, Vol. 57, No. 9, September, 1978.
14. Minard, L. C., et al, "Welding of Cu-Ni Clad Steel for Hull Plate," Welding Journal, AWS, Vol. 58, No. 5, May, 1979.
15. Prager, M. et al, "Welding a Copper-Nickel Clad Ship - COPPER MARINER II," Welding Journal, AWS, Vol. 59, No. 7, July, 1979.
16. Fu, J., et al, "Fourteen Months Experience with a Copper-Nickel Rudder," Sun Ship Report, 1977.

17. Sandor, L. W., "Cost Calculations of Roll Bonded Cu/Ni Clad Steel Weldments", Unpublished Report #43-26-77-7, Sun Ship, Inc., September 23, 1977.
18. Sandor, L. W., "Costing the Sheathing Method", Unpublished Report #43-26-77-8, Sun Ship, Inc., September 28, 1977.
19. "Welding of Copper-Nickel Clad Steels", INCRA Project No. 240, 1st-3rd Annual Report by INCO, September 1975-November 1977.
20. Fisher, S. M., "The Characterization of Copper-Nickel/Steel Weldments," Report, West Virginia Institute of Technology, April, 1980.
21. Benford, H., et al, "The Prediction of Hull Roughness and Its Use in an Economic Study of Cu/Ni Hull Applications vs. Conventional Steel Hulls", Unpublished Report, University of Michigan, December 15, 1978.
22. Townsin, et al, "Speed, Power and Roughness: The Economics of Outer Bottom Maintenance", Paper given @ RINA Spring Meeting, 1980.
23. Muntjewerf, et al, "Hull Deterioration and Fouling", Report, Appendix 7, Proceedings of 14th International Towing Tank Conference, 1975.
24. Hamlin, N., "Some Practical Considerations in Reducing Required Power for Ships", National Maritime Research Center, Kings Point, N.Y., Report NMRC KP-161.
25. Skepteknisk Forsknings Institutt (The Ship Research Institute of Norway), "Roughness Grades for Ship's Hulls", 1972. (Available BSRA translation: B190.)

APPENDIX

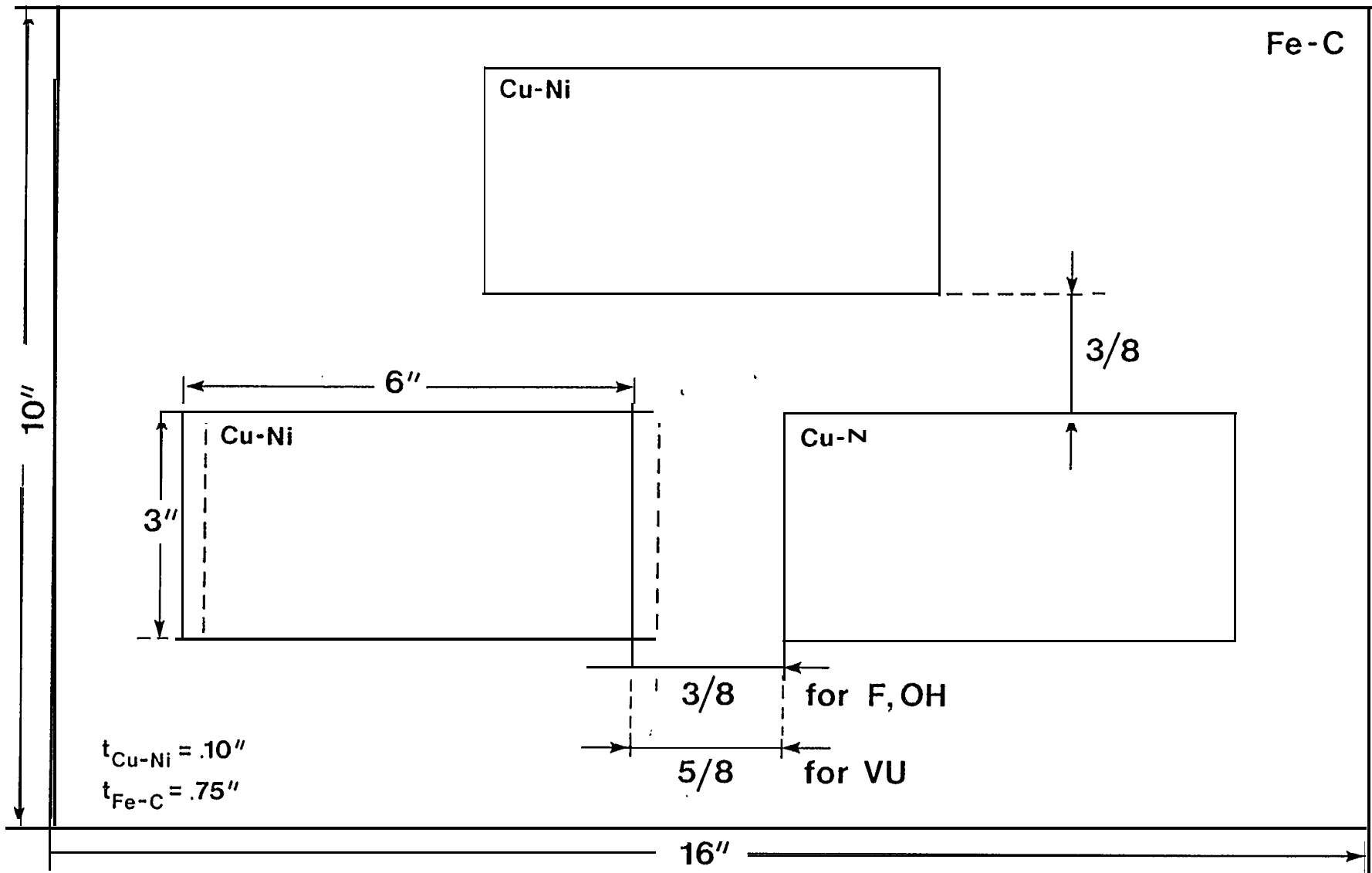
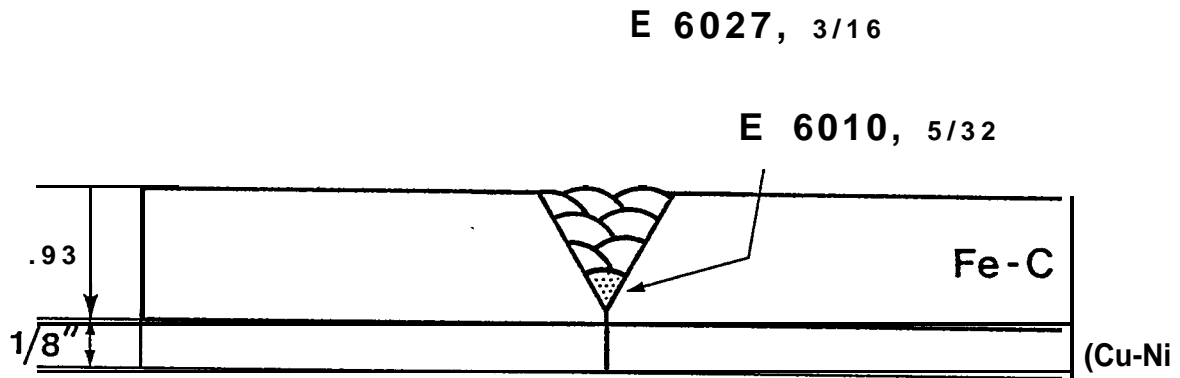

Fig. Scheme of Arrangement of Cu/Ni sheaths on steel.

# WELDING OF CLAD STEEL:

## STEP 1.



## STEP 2.

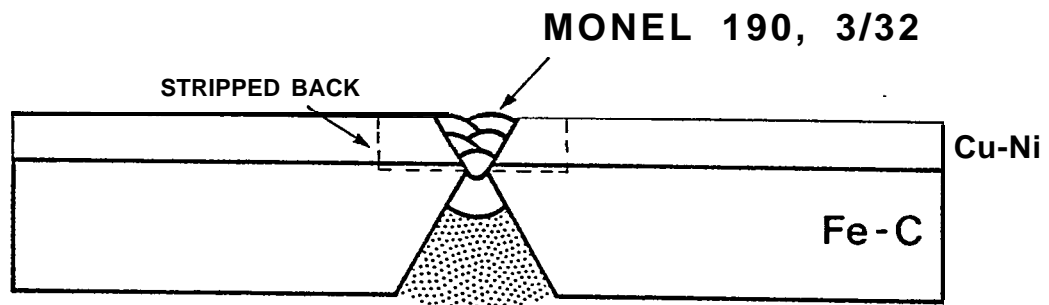

Fig. 2 - Graphical illustration of the welding of Cu/Ni. clad steel.

# ORIGINAL GAP SIZE BETWEEN Cu-Ni SHEATHS VERSUS WIDTH OF PENETRATION INTO STEEL SUBSTRATE OBTAINED

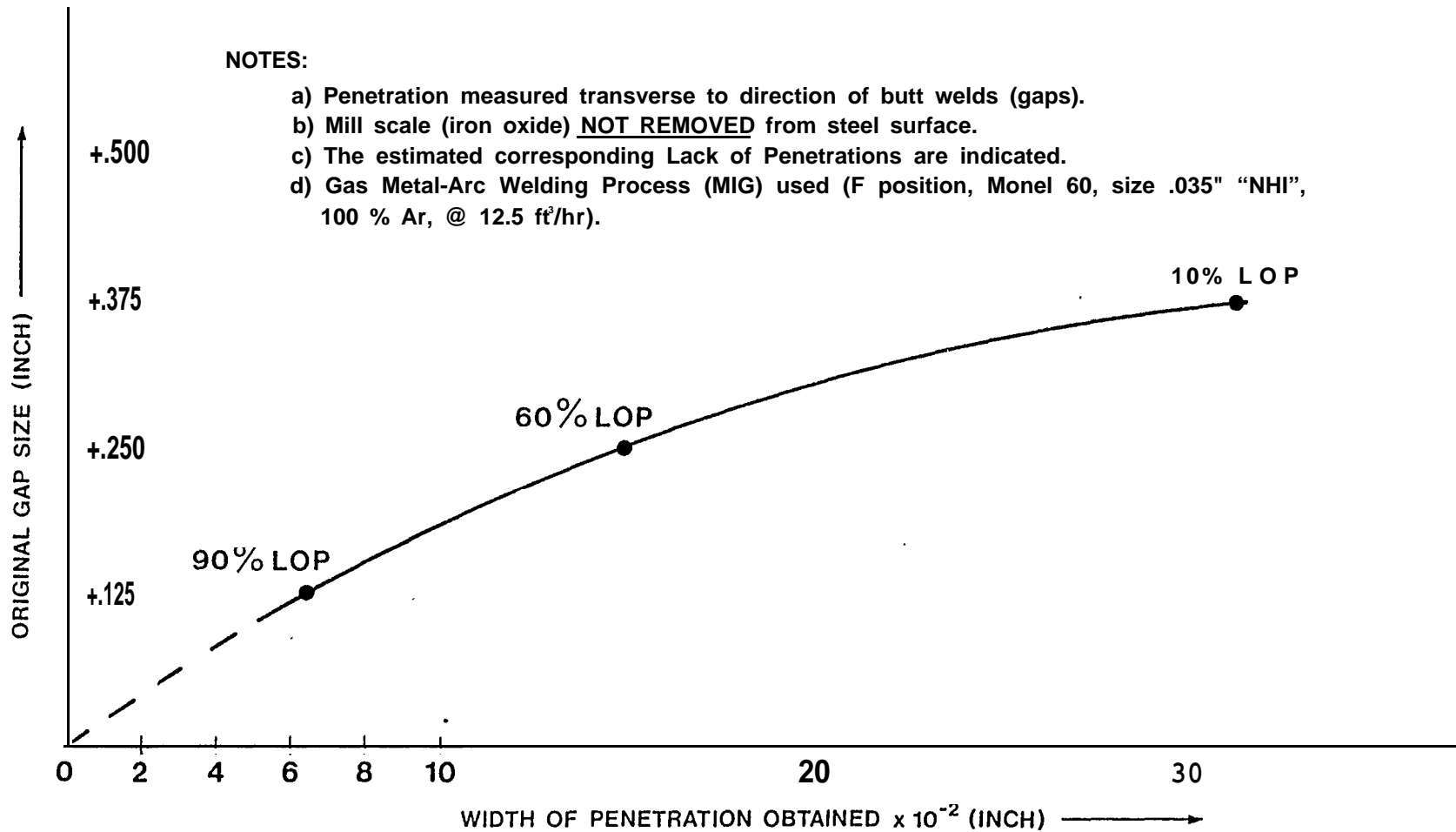
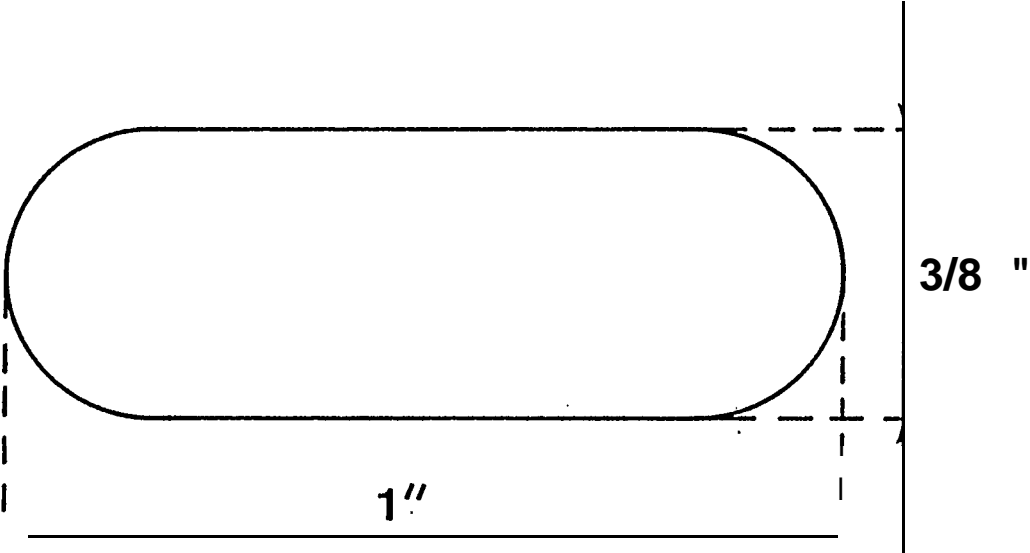
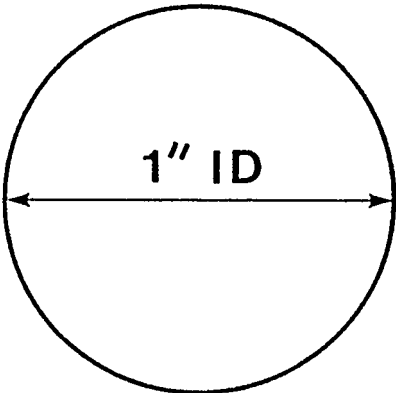

Fig. 3 - Plot of gap size versus width of weld penetration into the steel substrate for constant "Normal Heat Input" and travel speed conditions.

# ROUND PLUG vs. SLOT WELD



**PREFERRED**

**CONFIGURATION**

**WELD SEQUENCE: 2f+f-i**

**5A ↑ corresponding SEAM WELD**

Fig. 4 - Details of a round plug and a slot weld.

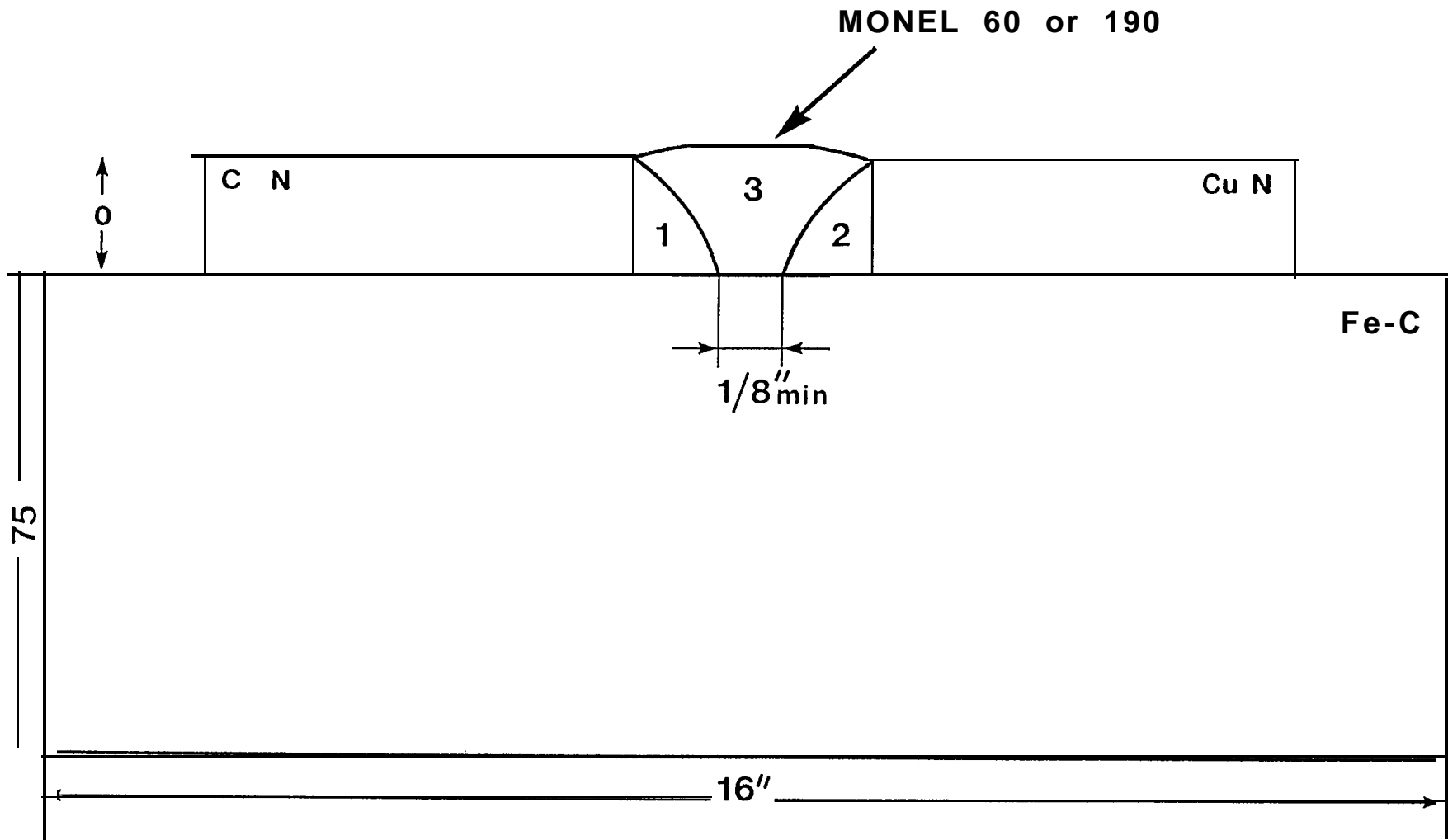

Fig. 5 - "Fillet welds and fill-in pass" methodology for welding Cu/Ni sheaths to the underlying steel hull plate.

## TENSILE SHEAR STRENGTH RESULTS OF 4 DIFFERENT ADHESIVES AS A FUNCTION OF Cu/Ni-STEEL SURFACE PREPARATION VARIABLES

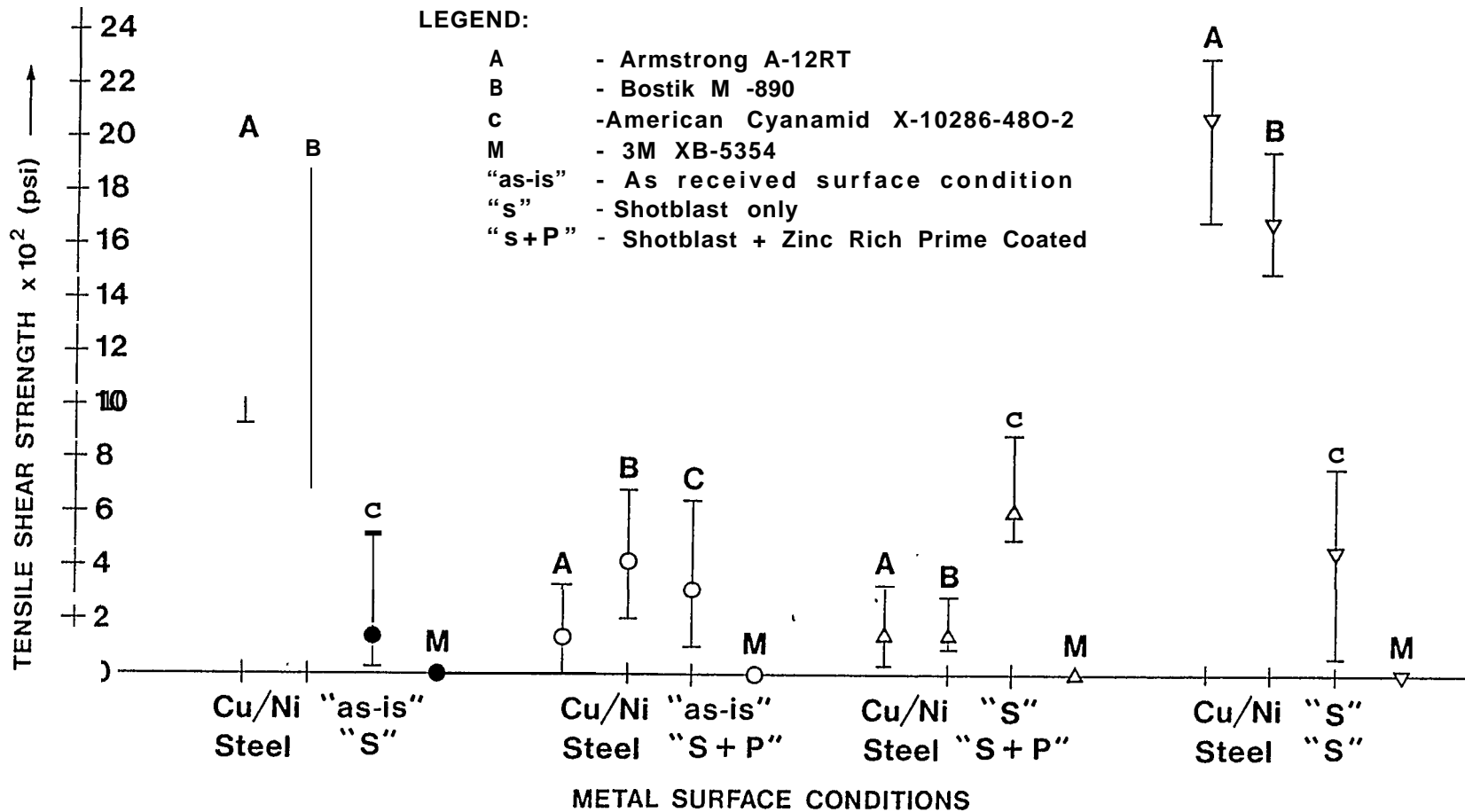

Fig. 6 - Tensile shear test results conducted with four different adhesives used to bond CA-706 copper/nickel alloy and ABS Grade A steel.

## PEEL STRENGTH RESULTS OF 4 DIFFERENT ADHESIVES AS A FUNCTION OF Cu/Ni-STEEL SURFACE PREPARATION VARIABLES

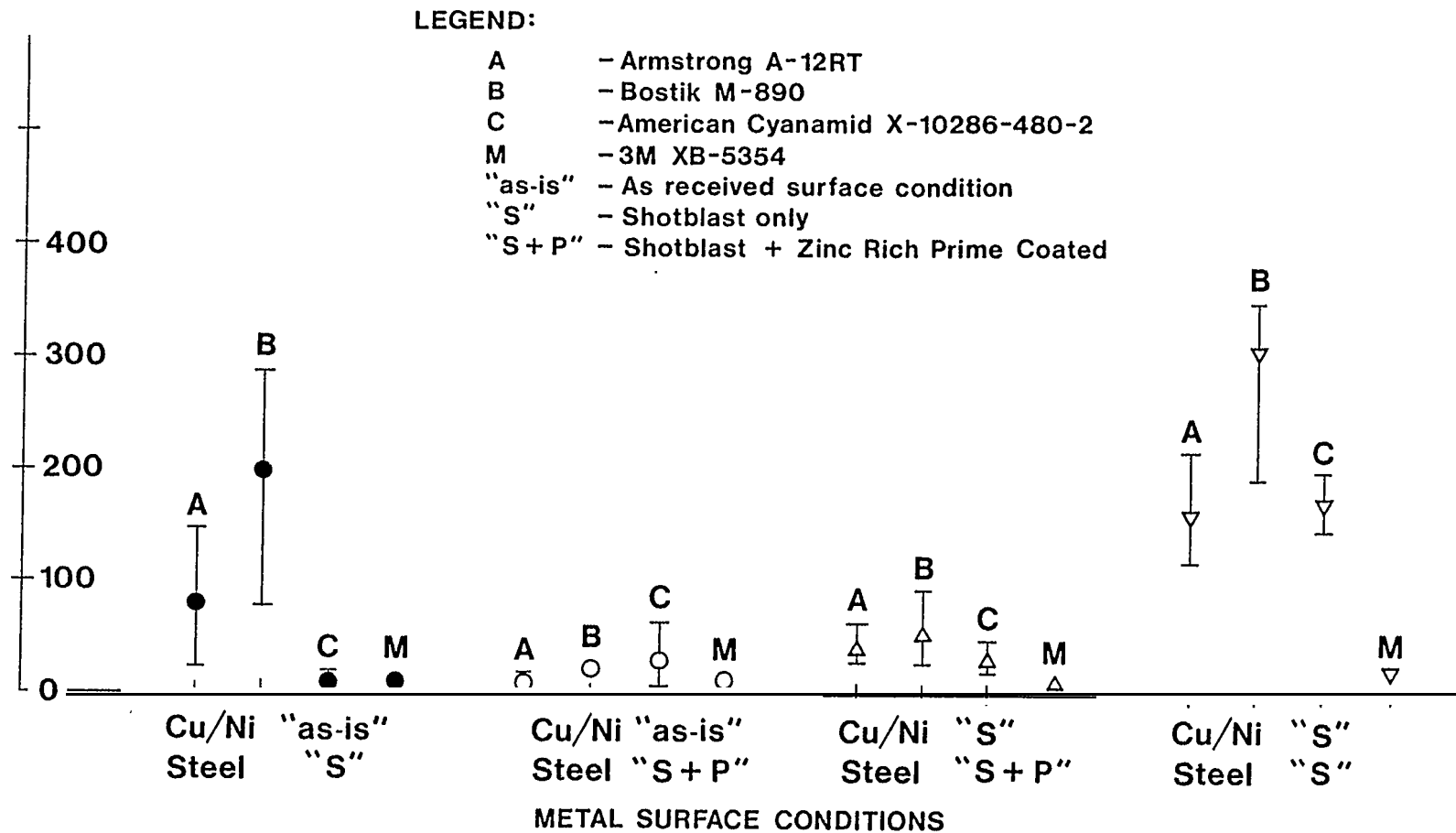

Fig. 7 - Peel test results conducted with four different adhesives used to bond CA-706 copper/nickel alloy and ABS Grade A steel.

## IMPACT TEST RESULTS OF 4 DIFFERENT ADHESIVES AS A FUNCTION OF Cu/Ni-STEEL SURFACE PREPARATION VARIABLES

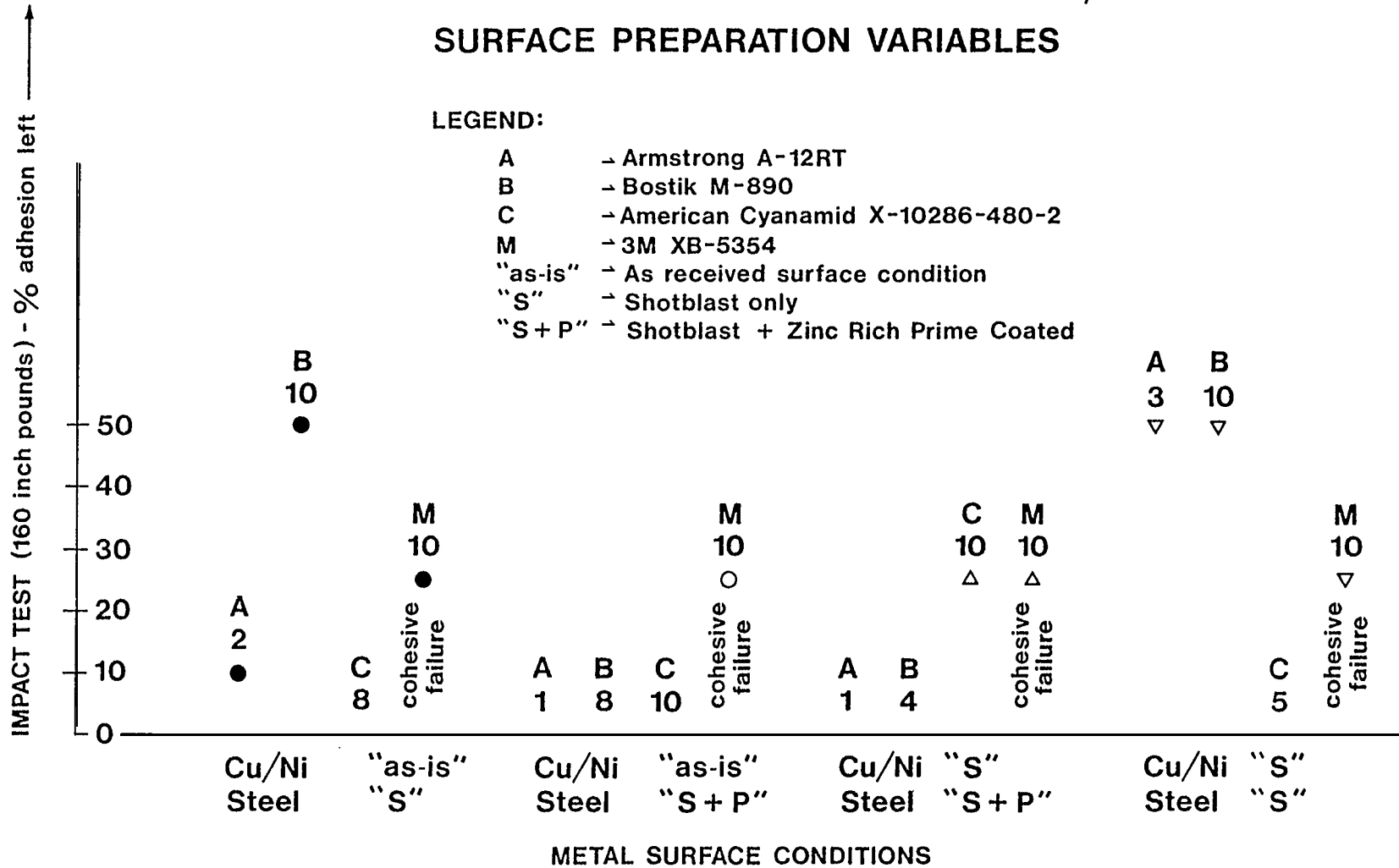

Fig. 8 - Impact test results conducted with four different adhesives used to bond CA-706 copper/nickel alloy and ABS Grade A steel.

## BEND TEST RESULTS OF 4 DIFFERENT ADHESIVES AS A FUNCTION OF Cu/Ni-STEEL SURFACE PREPARATION VARIABLES

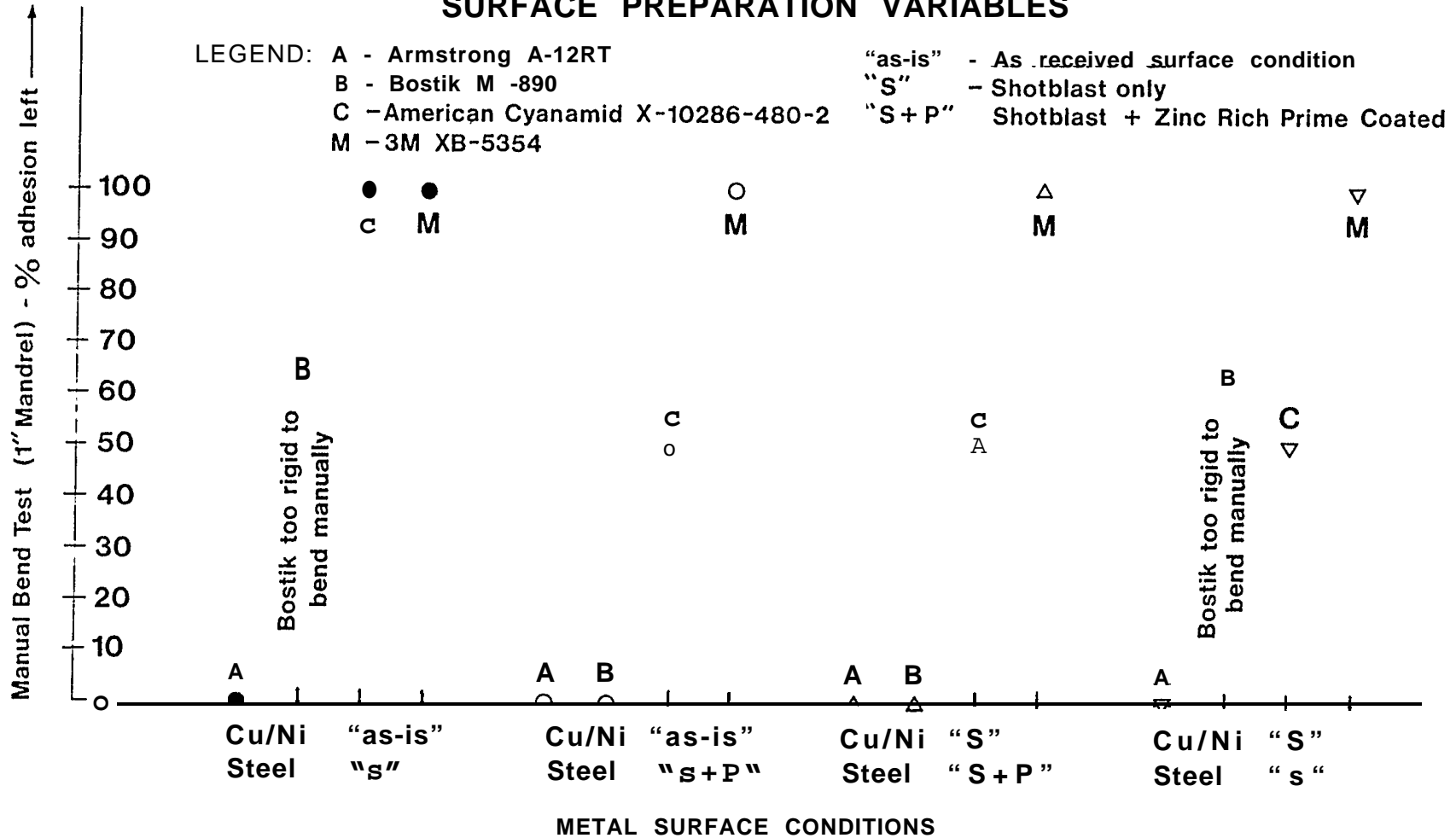
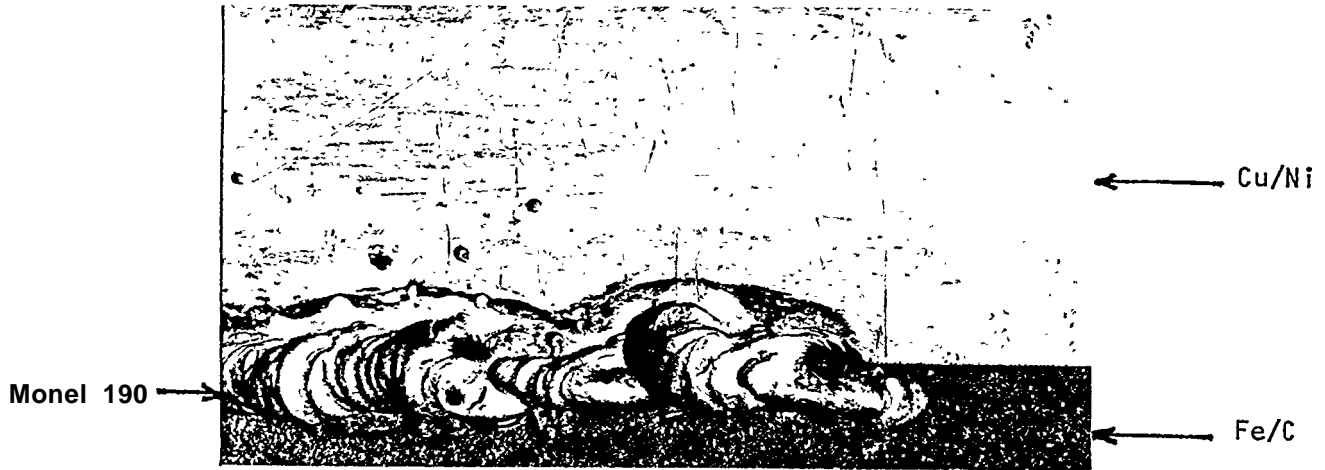

Fig. 9- Bend test results conducted with four different adhesives used to bond CA-706 copper/nickel alloy and ABS Grade A steel.



3M

original size



Best ik

original size

Fig. 10 - Weld quality adversely affected by zero adhesive clearance involving both the 3M and the Bostik adhesives.

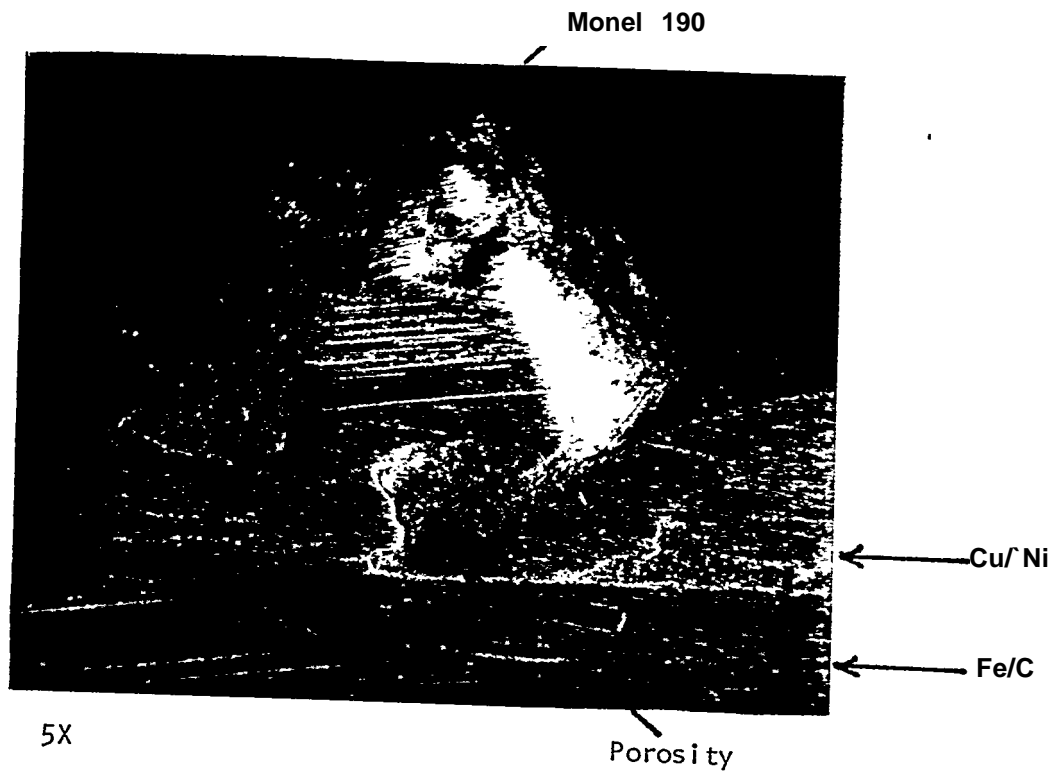
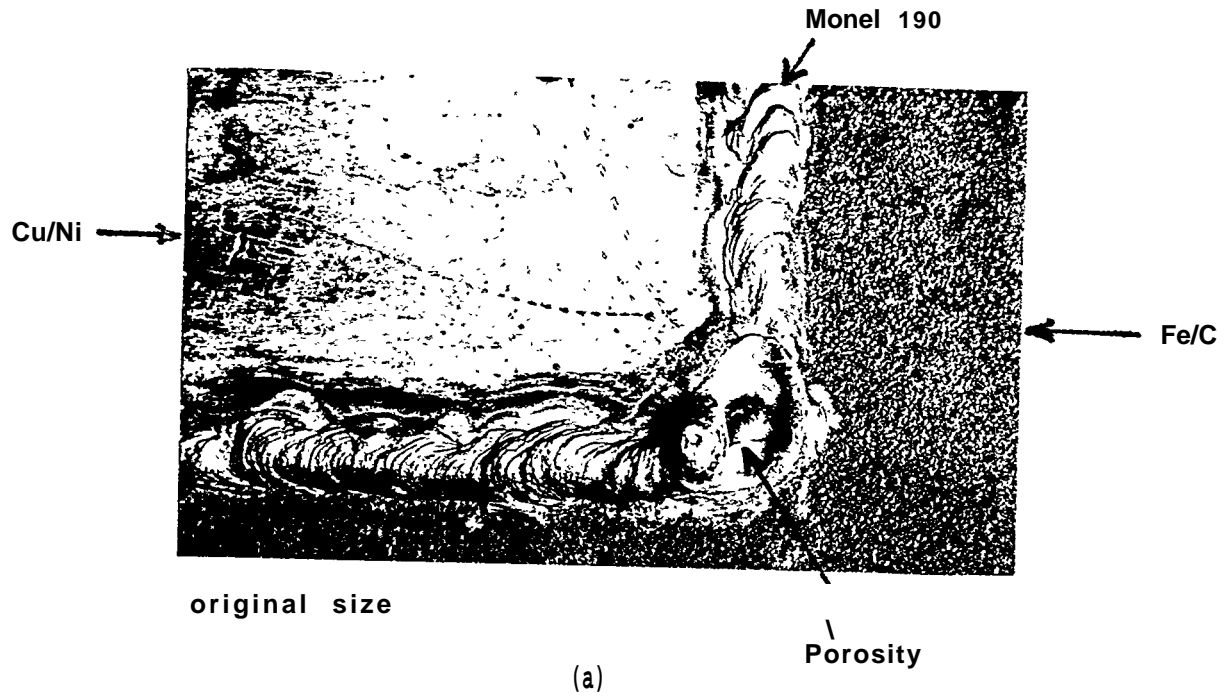

Fig. 11 - Large pore in the closing <sup>b)</sup> crater of a continuous peripheral fillet weld involving 3" x 6" x .10" Cu/Ni sample to a steel substrate. (a) Surface appearance of the pore, (b) Transverse cut through the pore. Note that 3M adhesive with 0.5 clearance was used in this bondweld experiment.

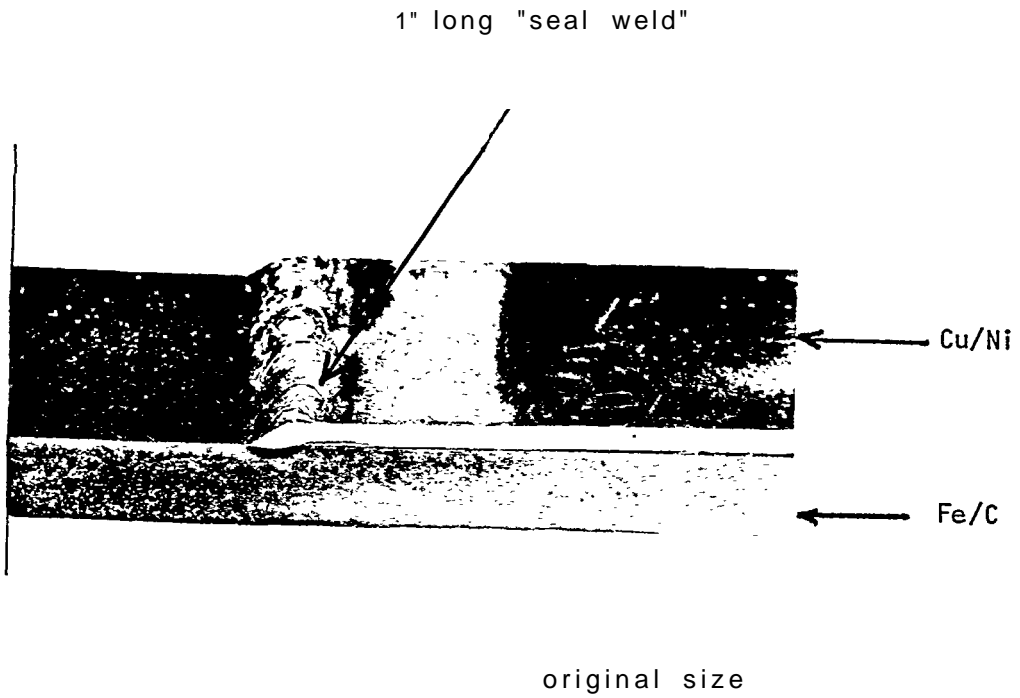

Fig. 12 - Same as in Fig. 11, except the bondweld Cu/Ni-Fe/C composite was allowed to cool to room temp before closing the peripheral fillet weld. Note the absence of porosity in the 1" "seal weld".

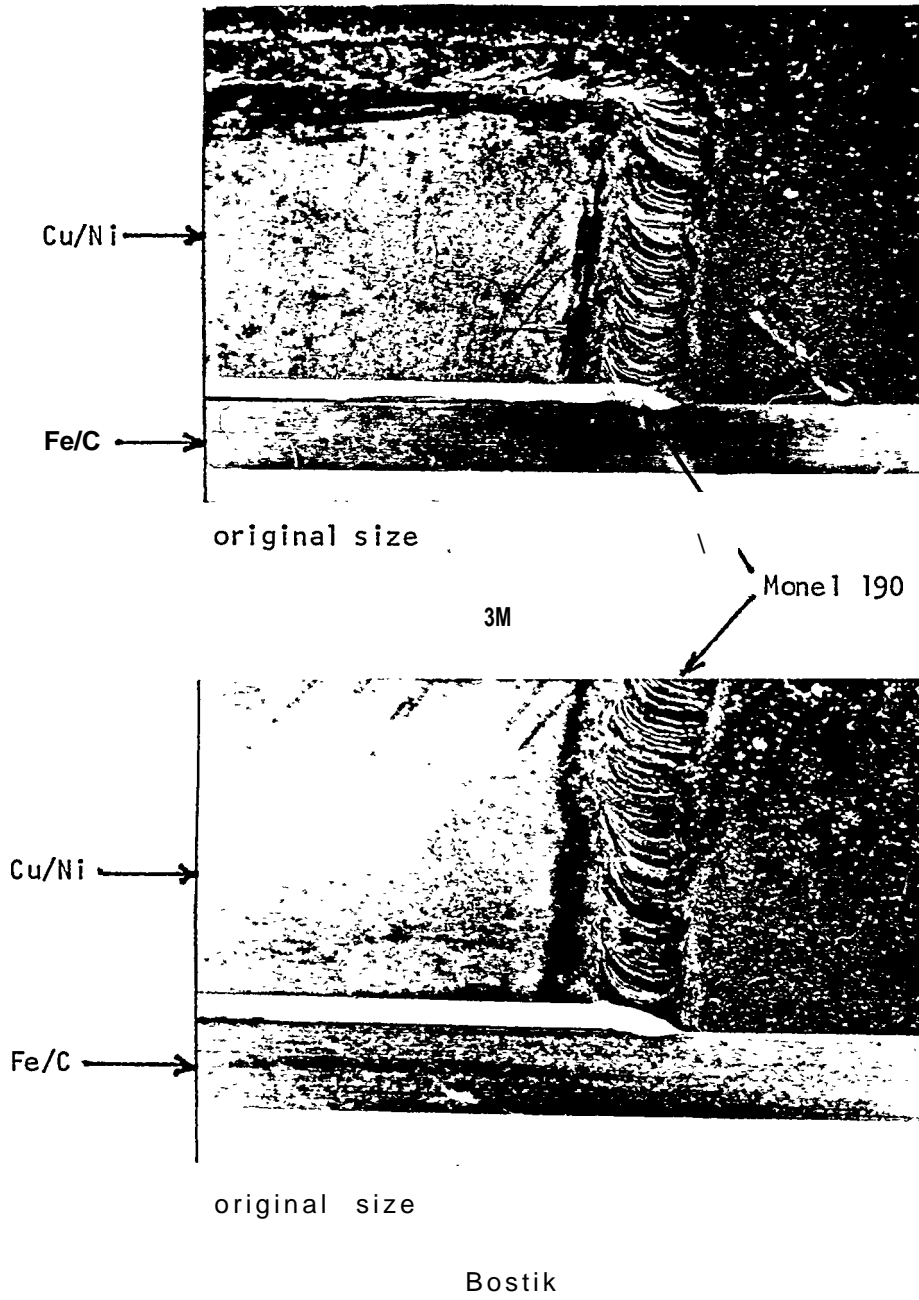

Fig. 13 1" clearance sample using 3M and Bostik adhesives showing no porosity even-when the composite was not allowed to cool to room temperature.

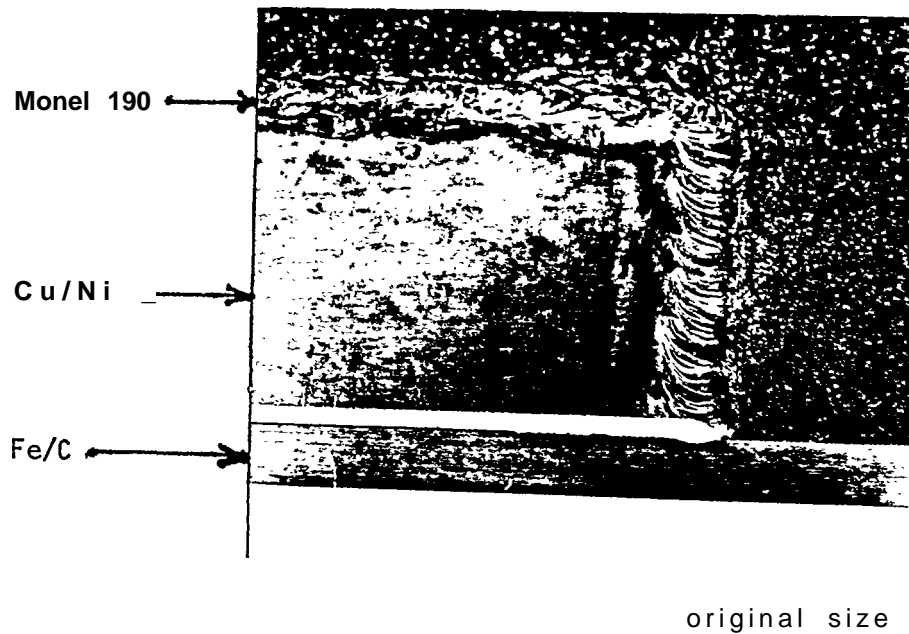
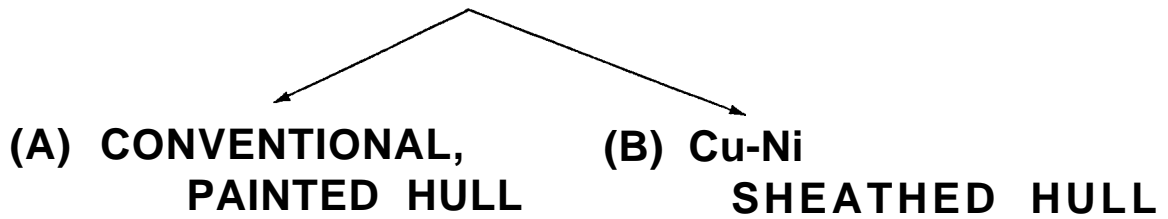

Fig. 14 Bostik adhesive with 0.5" clearance showing a sound weld.

# INITIAL COST ELEMENTS



A.1 shotblasting + material

B.1 sheathing material

A.2 painting + material

B.2 welding

A.3 add'l. staging for A.1 & A.2

B.3 grinding all welds

A.4 labor rates for A.1 - A.3

B.4 fitting & tacking

A.5 drydock & services

B.5 setting-up work area

A.6 incidentals

B.6 construction services

B.7 engineering

B.8 100% NDT

B.9 punching slots  
and/or adhesive(s)

B.10 profit (10%)

-TOTAL = \$.4 Million

\$3.6 -3.9 Million

$\Delta \overline{AB} = \$3.4 \text{ M}$  (average)

Fig. 15 Initial cost elements.

# MAJOR ELEMENTS of SAVINGS

## CONSIDERED for Cu-Ni

1. FUEL
2. REDUCED DRY-DOCKING (Biennial & Quadrennial)
3. ADDITIONAL REVENUE and PROFIT
4. PROPULSION PLANT REDUCTION
5. SCRAP VALUE Of Cu-Ni

	PURCHASE	SCRAP
Cu-Ni PRICE:	\$2.6946 per lb.	\$1.17 per lb. (minus labor) 50%

Ref. Hussey/Copper Range  
3 - 1 8 - 8 0

### ESTIMATED SAVINGS DUE TO 2. & 3. above

**BIENNIAL**

**\$136,000**

**QUADRENNIAL**

**\$103,000**

Fig. 16 Major elements of savings.

# ECONOMIC ASSESSMENTS

## NEW CONSTRUCTION

e.g.: Hull #678 (container ship)

**677'LBP 95' BEAM 54' DEPTH**

**23 knots @ 29.5' Draft 26,352 DWT**

**.4849 lb/SHP-HR @ Max. Power**

**30,000 SHP (108 RPM)**

**1,065 barrels/day**

**Bunker"C" \$21.00/barrel**

**(U.S.A. price, March 1980)**

**( international price is higher)**

**79,000 ft<sup>2</sup> WETTED SURFACE**

Fig. 17 Engineering specifics of a container ship used in the economic assessments.

**INFLATION ESCALATOR (over 21 years): 10%**

**ANNUAL OPERATING DAYS: 300**

**ANNUAL FUEL CONSUMPTION: \$6.0 Million @ 87% rated SHP**

**INCREMENTAL POWER RECIUREMENTS**

(Due to roughening of painted HULLS)

<u>YEAR</u>	<u><math>k_p</math> [mils]</u>	<u><math>\Delta P/P</math> [%]</u>
1	6	9.5
2	8	12.6
3	8	12.6
4	10	15.2
5	10	15.2
6	12	17.5
7	12	17.5
8	14	19.5
9	14	19.5
10	16	21.4
11	16	21.4
12	18	23.1
13	18	23.1
14	20	24.7
15	20	24.7
16	22	26.2
17	22	26.2
18	24	27.6
19	24	27.6
20	26	28.9

Fig. 18 **Additional** factors taken into account of the Cu/Ni hull sheathing economics.

\* Average (MAA) = initial + deterioration + fouling

1 1 Ref.: Townsin's paper;

$$100 \frac{\Delta P}{P} = 580 \left[ (k_p)^{1/3} - (k_{CN})^{1/3} \right]$$

where,

$100 \frac{\Delta P}{P}$  = required increase in SHP due to increasing roughness of painted hull [%]

$k_p$  = surface roughness of painted hull  
[MAA meters = MAA mils  $\times 25 \times 10^{-6}$ ]

$k_{CN}$  = surface roughness of Cu-Ni taken  
CONSTANT = 2 roils

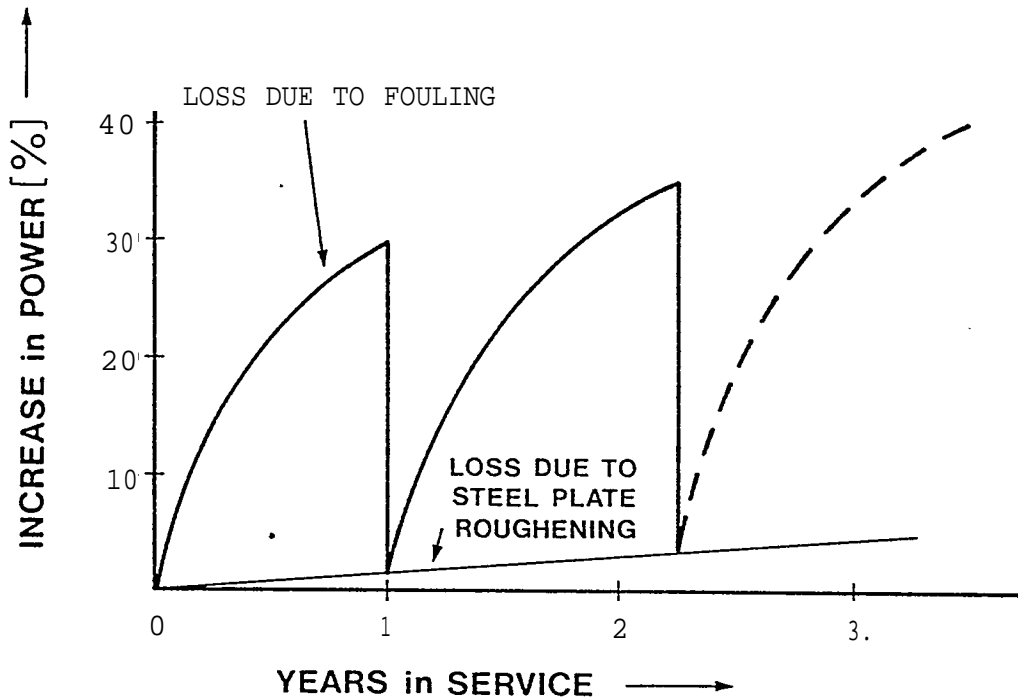

Ref.: Professor Benford 12-15-78

Fig. 19 Consequences of hull roughness due to fouling and base steel roughening with time on the shafthorsepower requirement.

CONSTRUCTION  
YEAR 1980

# COMPUTER INPUT DATA

No. of YEARS	0	1	2	3	4	5	6	7	8	9	0	11	2	13	14	15	16	17	18	9	20	TOTAL SAVINGS (\$ Million)
FUEL	—	.658	.959	1.055	1.400	1.540	1.957	2.146	2.630	2.893	3.493	3.842	4.562	5.018	5.903	6.493	7.576	8.333	9.657	10.622	12.235	92.966
DD and REVENUE	—	—	.173	—	.158	—	.253	—	.232	—	.370	—	.339	—	.542	—	.496	—	.793	—	.727	4.083
12% PP REDUCTION	400	—	—	—	—	—	—	—	—	—	—	—	—	—	—	—	—	—	—	—	—	400
Cu-Ni SCRAP	—	—	—	—	—	—	—	—	—	—	—	—	—	—	—	—	—	—	—	—	1.475	1.475
TOTAL SAVINGS	400	.658	1.132	1.055	1.558	1.540	2.204	2.146	2.862	2.893	3.863	3.842	4.901	5.018	6.445	6.493	8.072	8.333	10.45	10.622	12.962 + 1.475	98.92

w/ INITIAL INVESTMENT: \$3.4 Million & 46% Tax Rate

COMPUTER RESULTS:

ZERO-INTEREST BREAKEVEN POINT: 5.22 years or 4.22 yrs. FROM START-UP

EFFECTIVE DCCR: 33.45%

Fig. 20 Computer input data showing the results of economic analysis conducted.

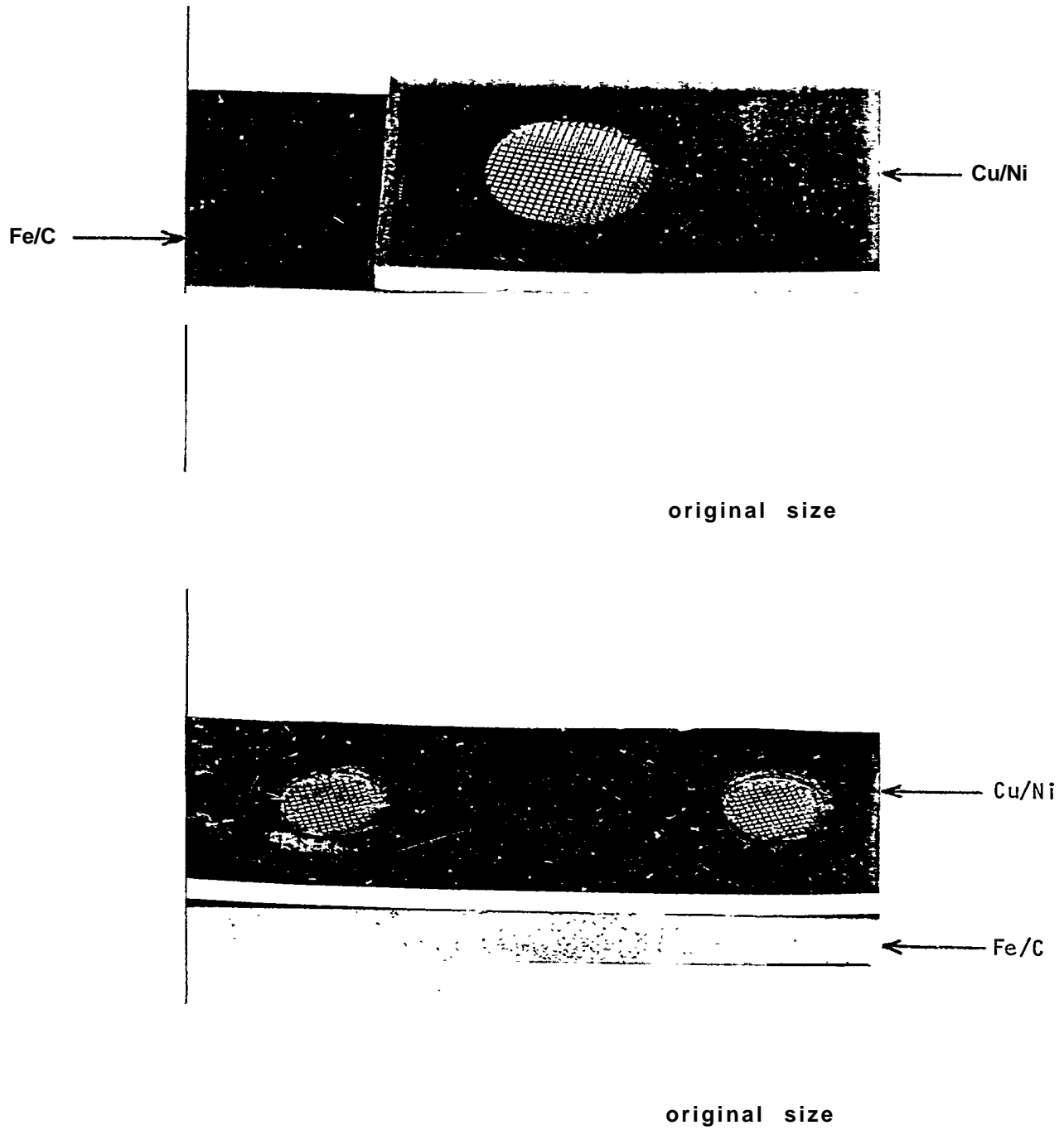

Fig. 21 Examples of conventional ultrasonic welding of Cu/Ni-Fe/C composite ship hull materials.

TABLE I

Chemical Composition of Alloy CA-706

(Values given in weight percent)

Cu	Ni	Fe	Mn	Pb	P	S	C
88.6	9.0-11.0	1.0-1.8	1.0 max	.02 max	.02 max	.02 max	.05 max

**TABLE II**

Some of the Principal Welding Data Used in the Final Laboratory Phase

Welding Process	Welding Current (Amps)	Voltage (volts)	Current Type and Polarity	Filler	Metal	Shielding		Pre-Heat	Post-Heat
				Type	Size	Gas	Flow Rate (ft <sup>3</sup> /hr)		
SMAW	80, F*	-	DCRP	ENi Cu-2	3/32"	-	-	None	None
	80, H*	-	DCRP	ENi Cu-2	3/32"	-	-	None	None
	75-80, VU*	-	DCRP	ENi Cu-2	3/32"	-	-	None	None
	75, OH*	-	DCRP	ENi Cu-2	3/32"	-	-	None	None
MIG (1)	230, F*	24	DCRP	ERNi Cu-7	.035"	100% Ar	12.5	None	None
	230, H*	24	DCRP	ERNi Cu-7	.035"	100% Ar	12.5	None	None
	230, VD*	24	DCRP	ERNi CU-7	.035"	100% Ar	12.5	None	None
	180, OH*	22	DCRP	ERNi CU-7	.035"	100% Ar	12.5	None	None

\*F - Flat Position  
H - Horizontal Position  
vu - Vertical Up Position  
VD - Vertical Down Position  
OH - Overhead Position

(1) Welding currents indicated pertain to "Normal Heat Input" conditions (@ wire speed of 8 ipm for F, H, VD, and @ 6.4 ipm for OH)

Note: The maximum allowable interpass temperature for SMAW: in OH 200°F  
vu 350°F  
H & F not important (to make good welds)

TABLE III (A)

Results of "Screening" Tests Conducted on Four Different Adhesives

(Ref.: DL Labs, 1979)

TEST METHOD	SURFACE PREPARATION		ARMSTRONG (A-12RT)		BOSTIK (M890)		CYANAMID (X-10286-480-2)		3M (XB-5354)	
	Cu/Ni	Fe/C	Avg (psi)	Range (psi)	Avg (psi)	Range (psi)	Avg (psi)	Range (psi)	Avg (psi)	Range (psi)
TSS(1)	as is	S+P	128	4-336	421	196-664	352	92-628	4	2-4
Ps (2)			7	4-20	27	22-28	<b>31</b>	6-58	9	8-10
TSS	as is	S	1544	920-1960	1279	660-1916	<b>128</b>	16-522	8	6-12
Ps			81	16-138	199	<b>68-292</b>	<b>8</b>	4-16	13	12-14
TS S	s	s+p	146	20-320	148	<b>96-284</b>	<b>606</b>	508-870	15	12-20
Ps			34	20-56	45	<b>24-92</b>	<b>28</b>	14-50	9	8-10
TS S	s	s	2050	1682-2300	1708	<b>1504-1944</b>	<b>468</b>	40-752	2	2-2
Ps			156	120-216	304	194-362	169	144-200	20	18-24

(1) TSS = Tensile Shear Strength

(2) Ps = Peel Strength

TABLE III (B)

Results of "Screening" Tests Conducted on Four Different Adhesives

(Ref.: DL Labs, 1979)

TEST METHOD	SURFACE PREPARATION		ARMSTRONG (A-12RT)		BOSTIK (M890)		CYANAMID (X-10286-480-2)		3M (XB-5354)	
	Cu/Ni	Fe/C	% Adh. Left	# of Impacts	% Adh. Left	# of Impacts	% Adh. Left	# of Impacts	% Adh. Left	# of Impacts
BT(1)	as is	S+P	0		0		50	-	100	-
IT(2)			0	1	0	8	0	10	25*	10
BT	as is	s	0		**		100		100	-
IT			10	2	50	10	0	8	25*	10
BT	s	s-l-P	0		0		50	-	100	-
IT			0	1	0	4	25	10	25*	10
BT	s	s	0		**		50	-	100	-
IT			50	3	50	10	0	5	25*	10

(1) BT = Bend Test Over 1" Dia. Mandrel

(2) IT = Impact Test ((Test sample hit with 160 inch pounds (4 lbs. weight fallen from 40" height); maximum number of hits being 10)).

\*Cohesive failure (i.e., failure in adhesive as opposed to failure at interface between adherend and adhesive called adhesive failure). All other failure modes were of the adhesive type.

\*\*Bonded test sample so rigid as to prevent bending manually.

**TABLE IV**

SMAW Requirements for Optimum Results in Specific Weld Positions

Weld Position	W e l d i n g				Electrode			Interpass Temperature (°F)	Gap Size Between Cu/Ni Panels (in)
	Current (amps)		Type	Polarity	Type	Size (in)			
	"2f"	"f-i"				"2f"	"f-i"		
F	80	120	DC	R	Monel 190	3/32	1/8	*	3/8
H	80	120	DC	R	Monel 190	3/32	1/8	*	3/8
vu	75-80	90-120	DC	R	Monel 190	3/32	1/8	350 max.	5/8
OH	75	75	DC	R	Monel 190	3/32	3/32	200 max.	3/8

\*Not important from the standpoint of making a sound weld.

NOTE: (a) Voltage was not measured. Used OC setting.

(b) Weld current for slot welding should be 5 amps higher than that of corresponding weld positions for peripheral welds.

TABLE V

SMAW Parameters Used in Combination Filler Metal Experiments

WELD POSITION	ELECTRODE*		WELD CURR		ENT	GAP SIZE (in)
	Size (in)	Type	(amps)	Type	Polarity	
F	3/32	Monel 90	80	DC	R	3/8
F, H	1/8	Monel 90	120	DC	R	3/8
vu	1/8	Monel 90	90	DC	R	5/8
OH	1/8*	Monel 190	90	DC	R	3/8

\*Too large for OH welding. Therefore, in OH position, use 3/32 electrode size only, to obtain best weld profile (flush).

PHOTOGRAPHS

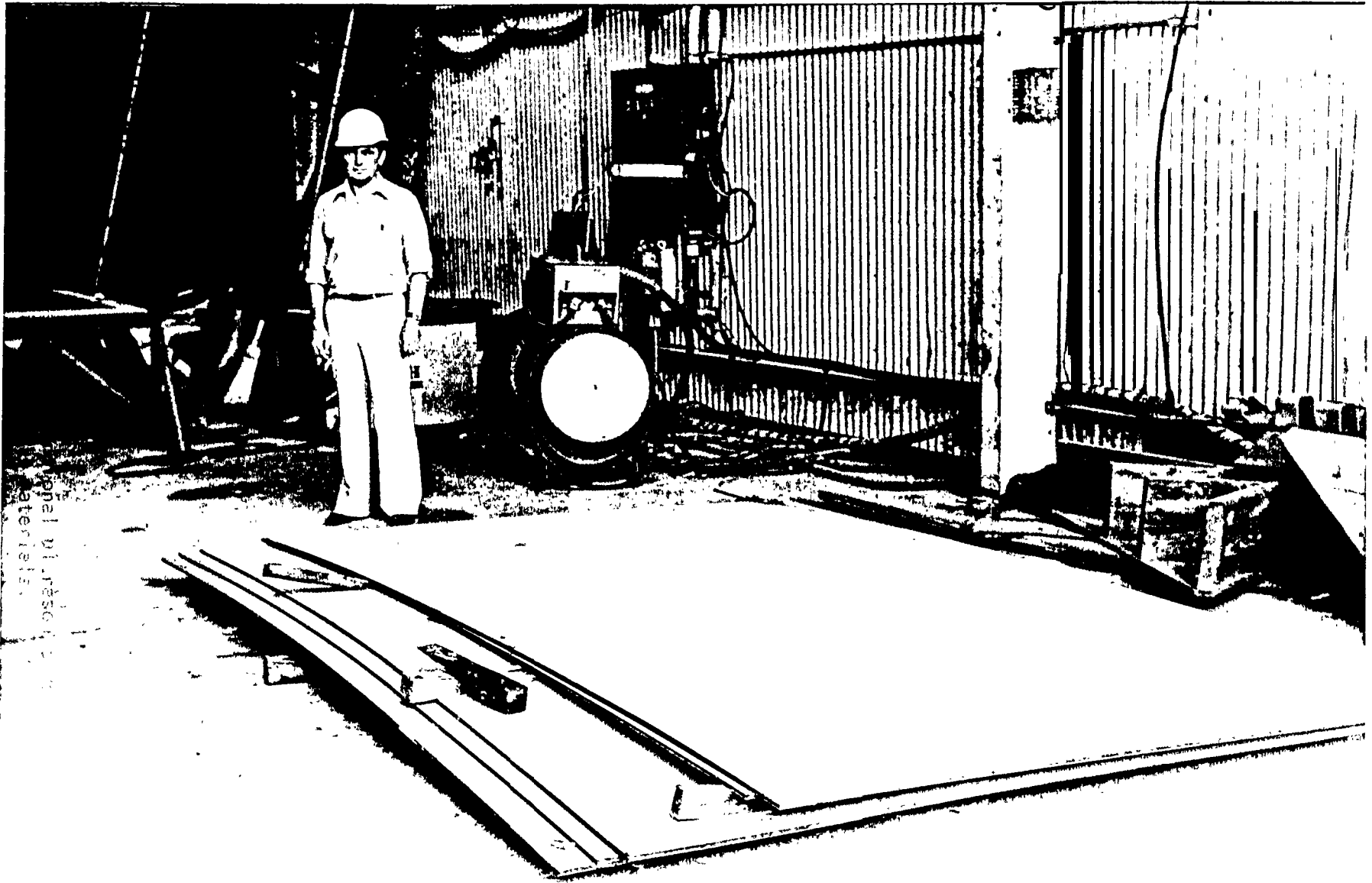

Fig. 22 Preproduction prime coated steel hull plates - size 7' X 12' X .4375" - used in the final Laboratory Phase of the project.



Fig. 23 Three (3) copper/nickel sheaths size 3' X 5' X 10" - tack welded on a primed steel hull plate.

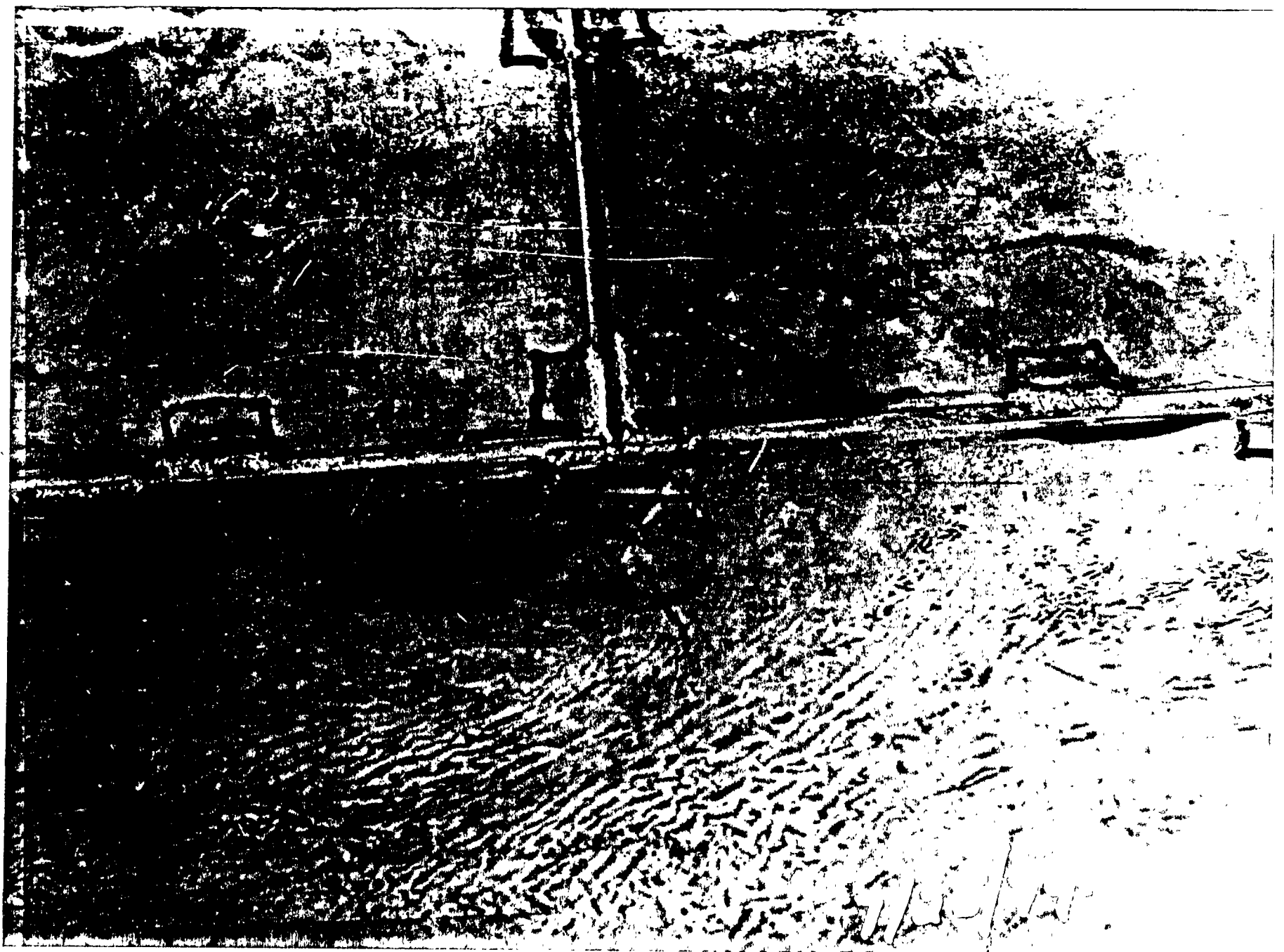

Fig. 24 A close-up view of tacked Cu/Ni panels.

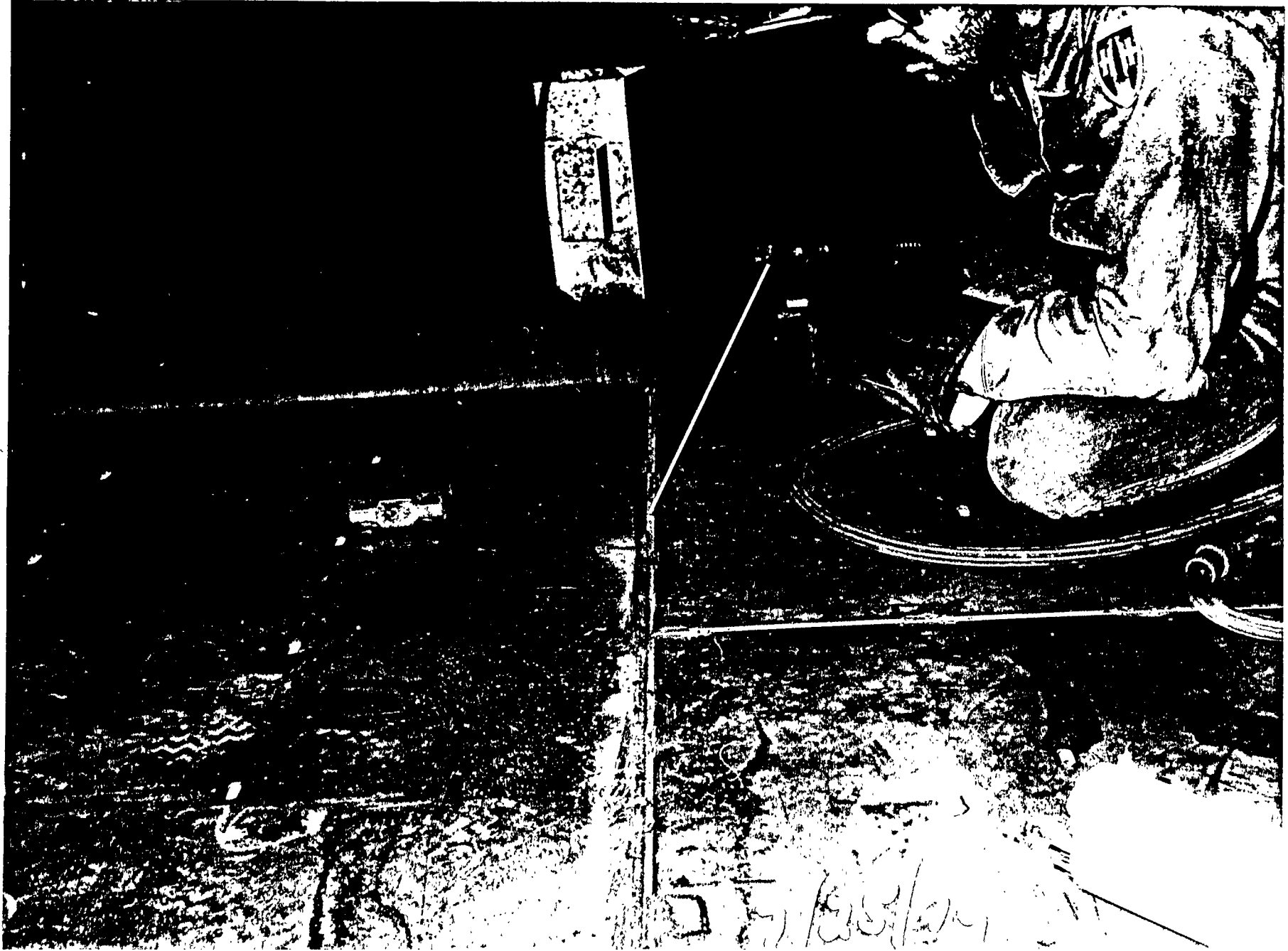

Fig. 25 The first fillet weld of the "2f" portion of "2f+f-i" weld sequence.



Fig. 26 Peripheral welding in the horizontal position using SMAW.



Fig. 27 shielded metal-arc welding in the overhead position.

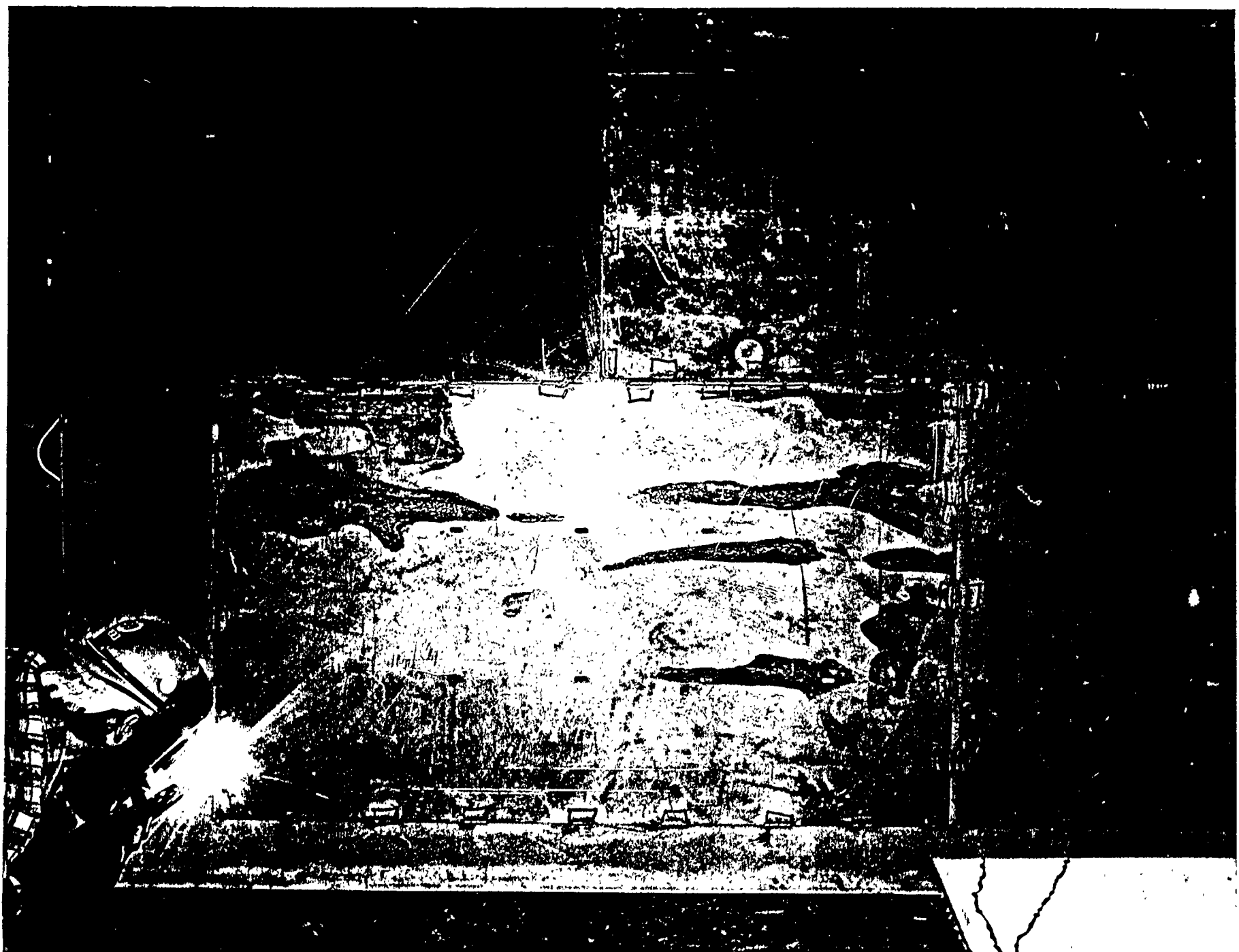

Fig. 28 Peripheral welding in the vertical-up position using SMAW.

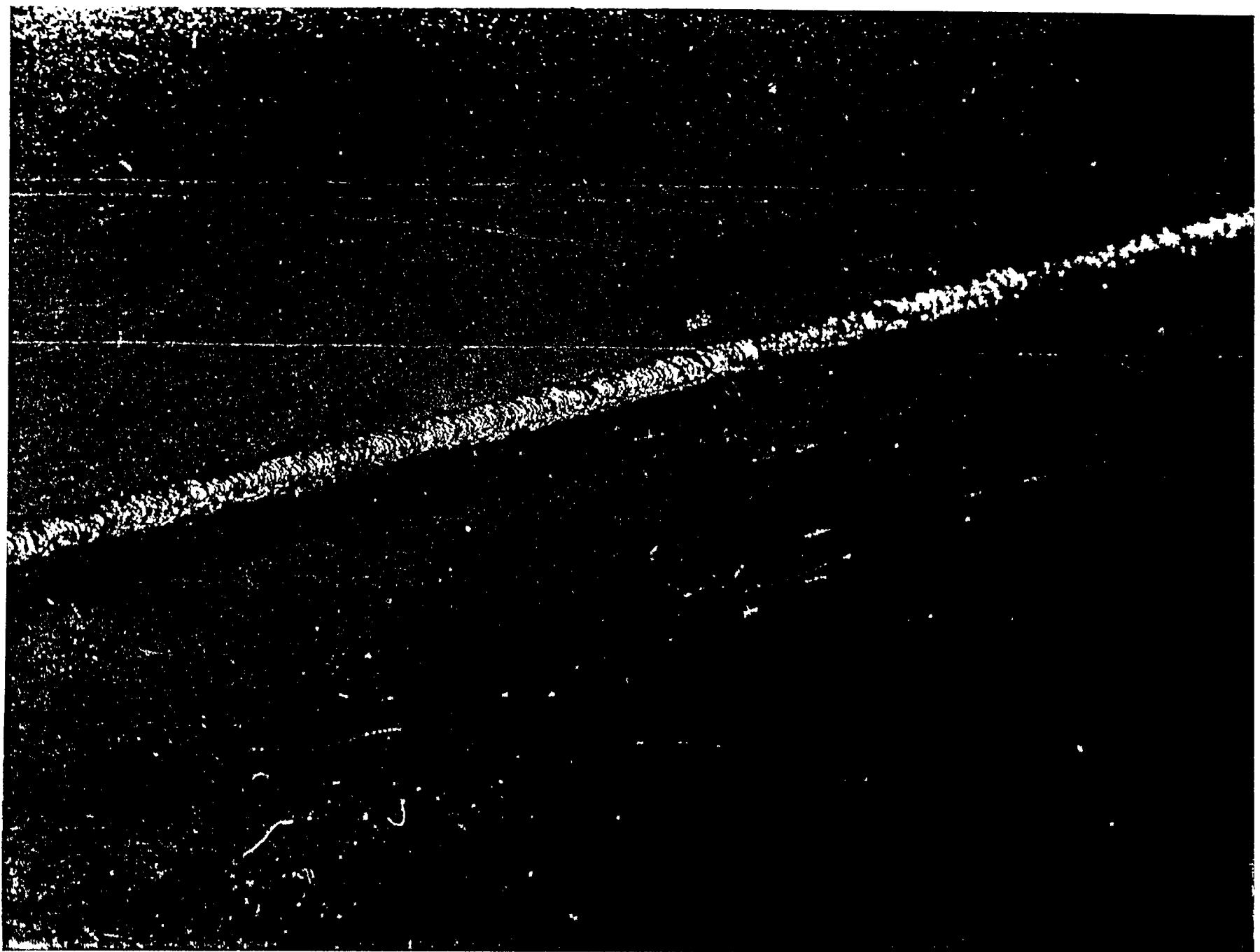

Fig. 29 A close-up view of a peripheral weld (or a fillet weld). The marking on the Cu/Ni indicates an original tack weld.

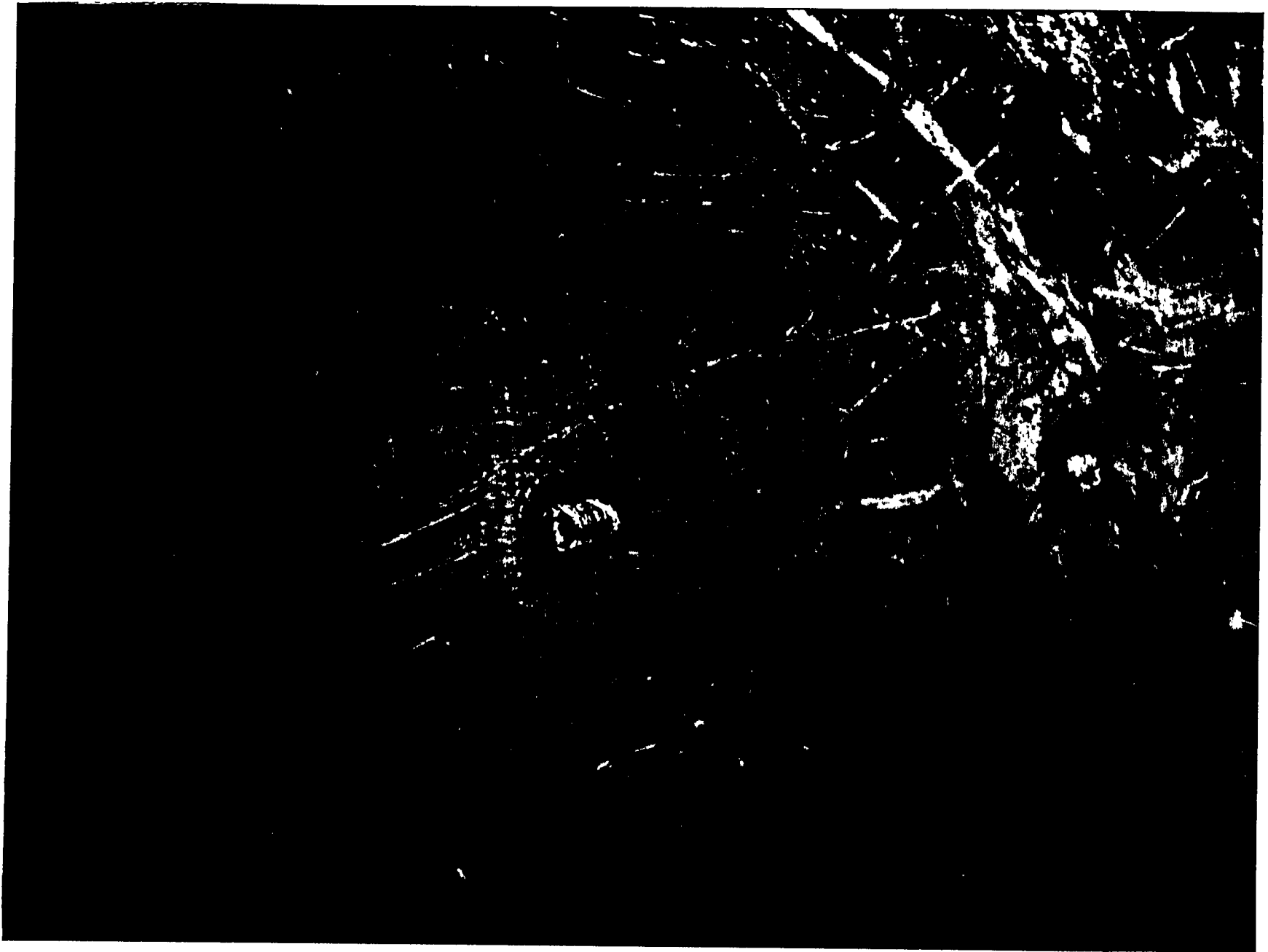

Fig. 30 A close-up view of slot welds in a Cu/Ni panel (F position),



Fig. 31 A close-up picture of an overhead position slot weld in a Cu/Ni sheath.

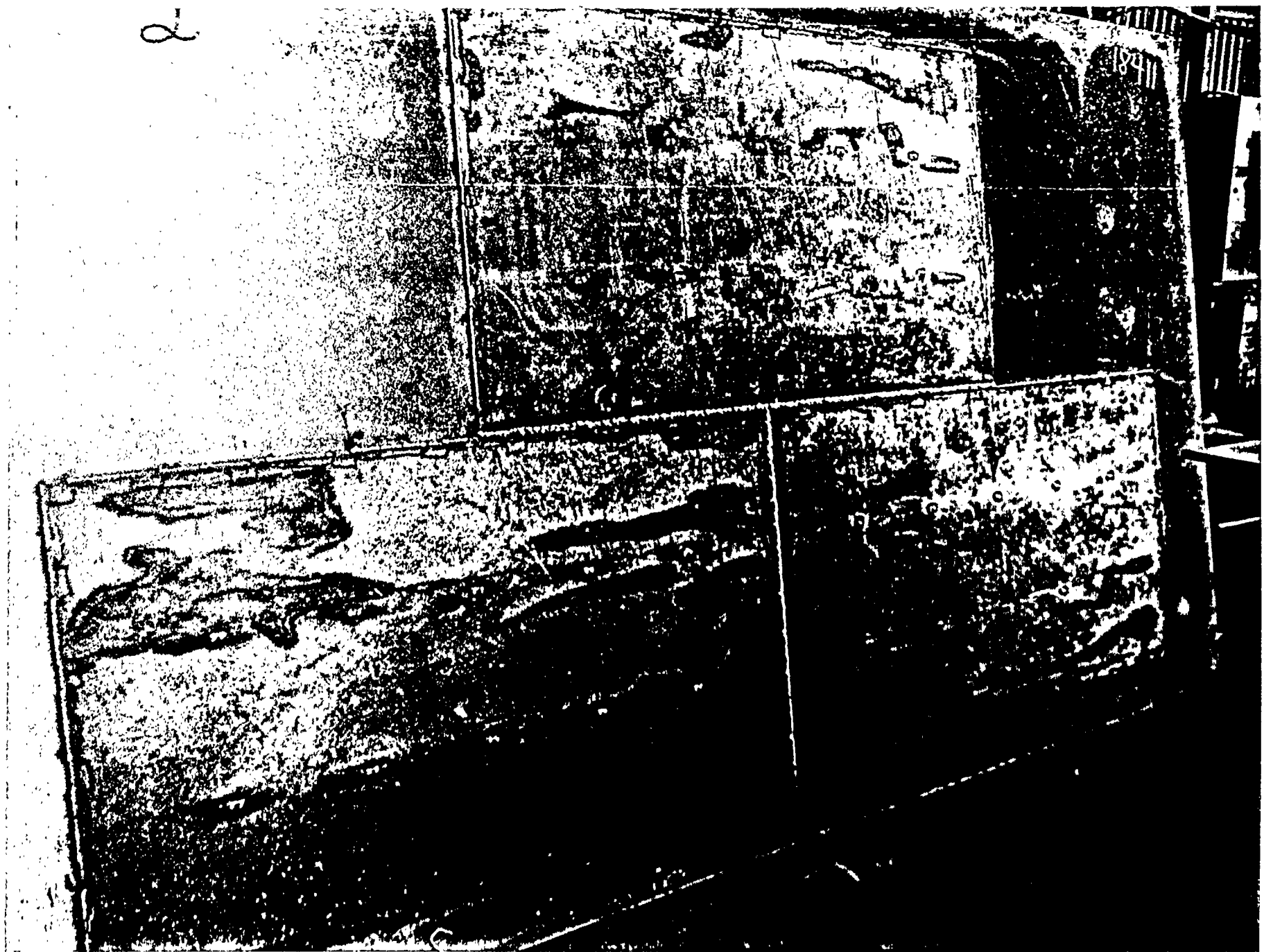

Fig. 32 A general overview of three Cu/Ni sheaths welded to a primed steel plate in horizontal and vertical (butt weld between the two sheaths on the bottom and fillet welds on the ends of each sheath) position.

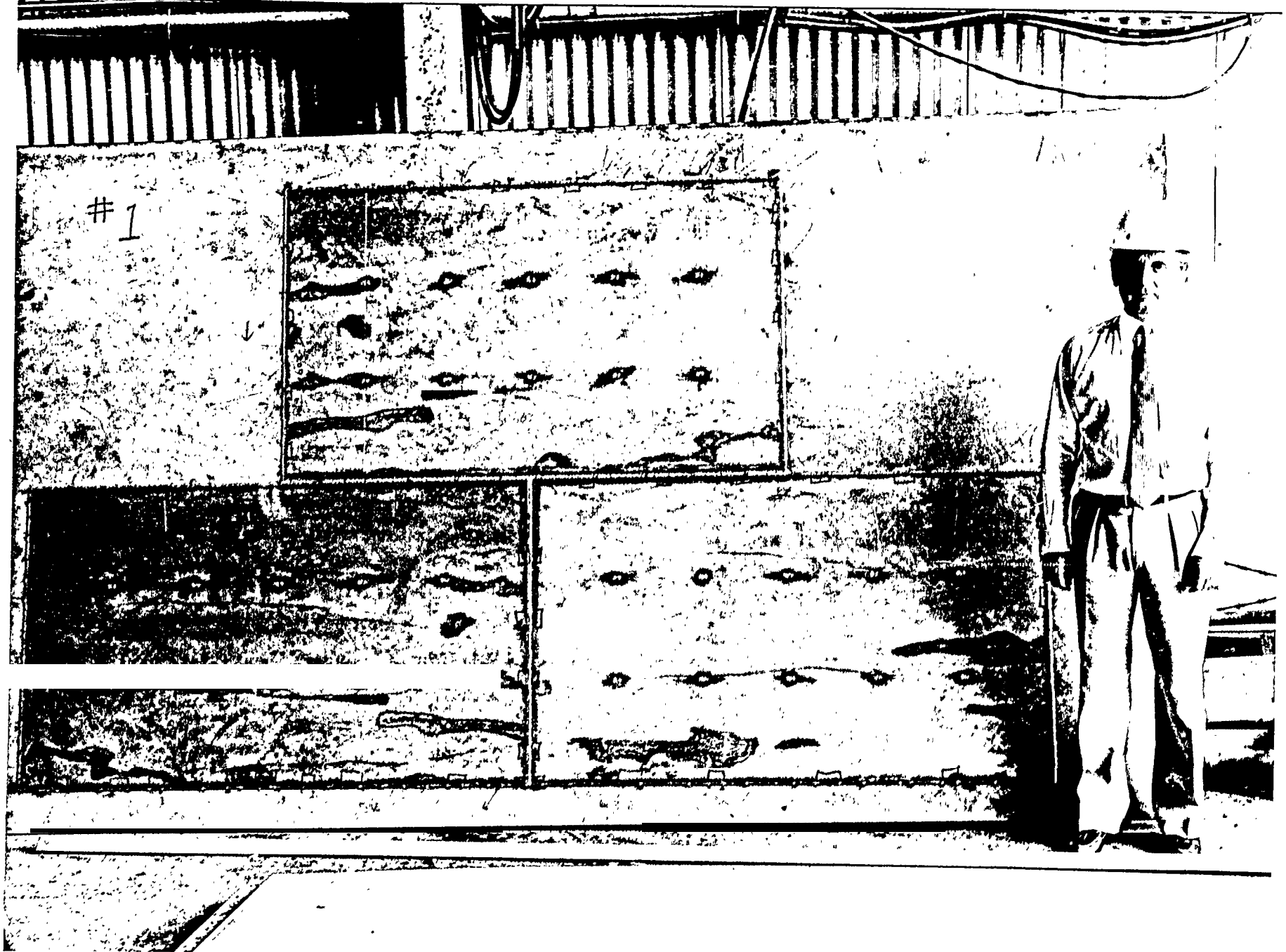

Fig. 33 A photograph showing the relative size of a copper/nickel-steel composite ship hull material after completion of all the welds done in the flat position.

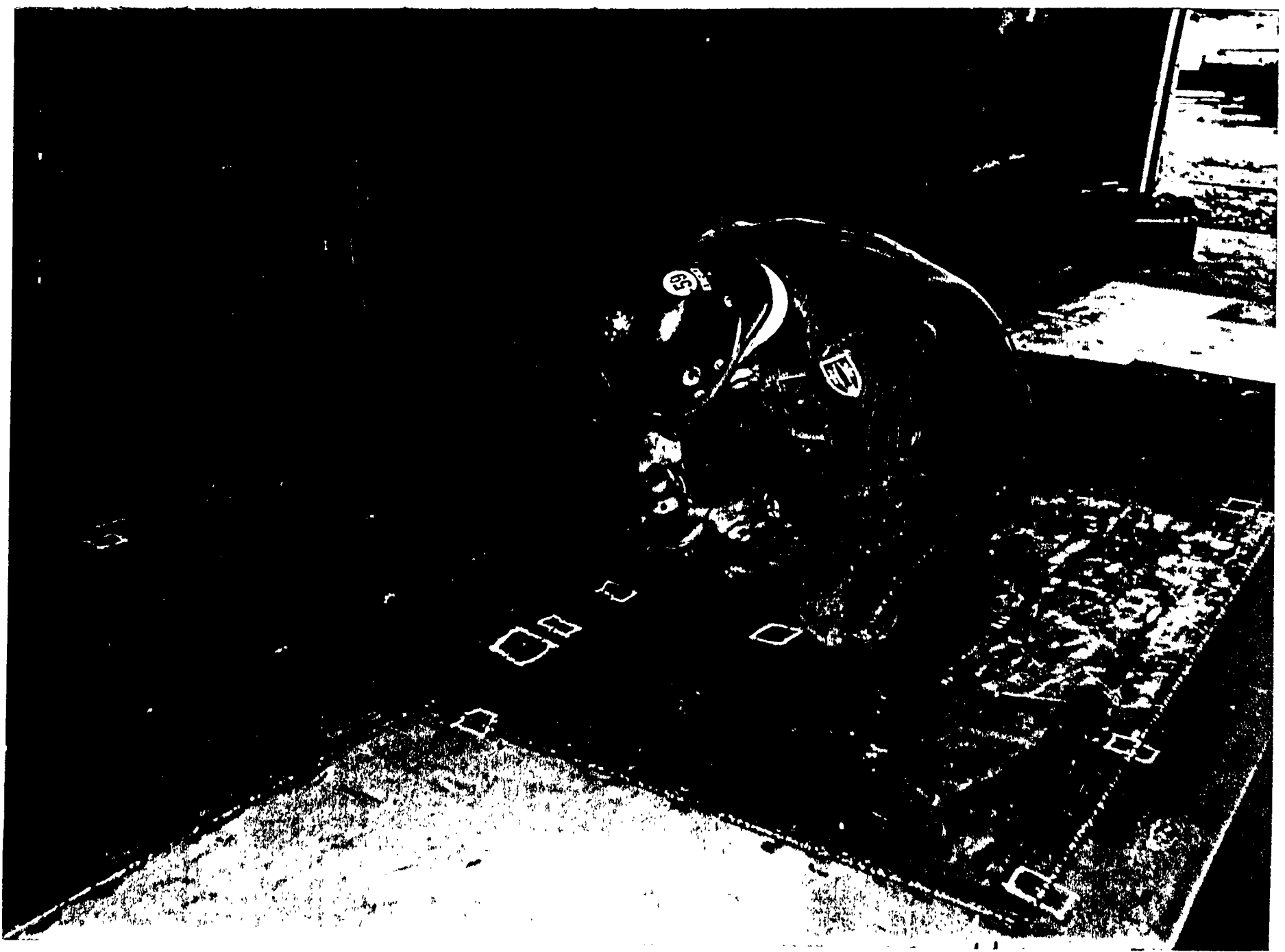

Fig. 34 Start of grinding all the welds flush with the Cu/Ni surface.

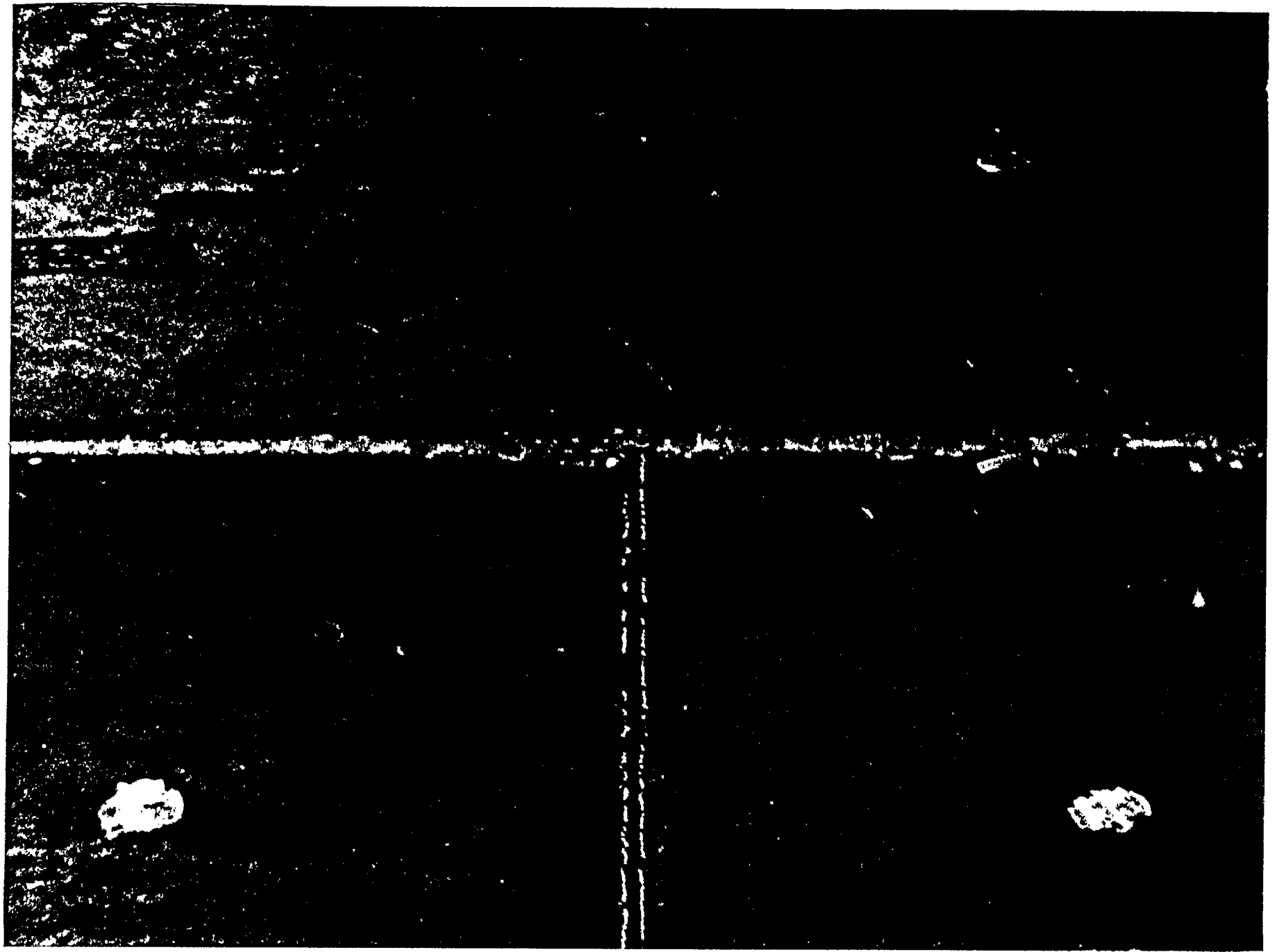

Fig. 35 A close-up photograph of the welds after hand grinding.

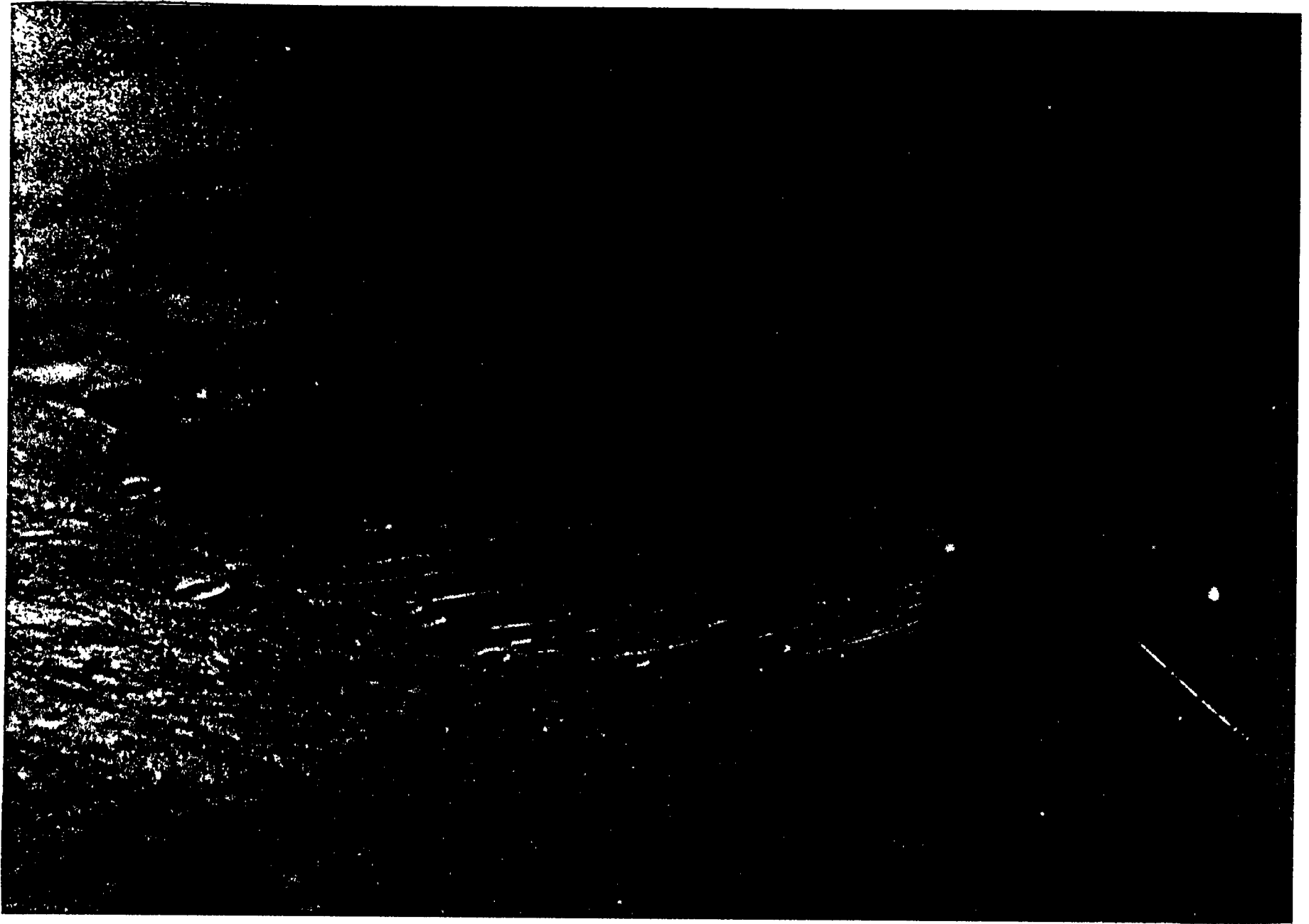

Fig. 36 A close-up picture of a slot weld ground flush with a Cu/Ni panel.

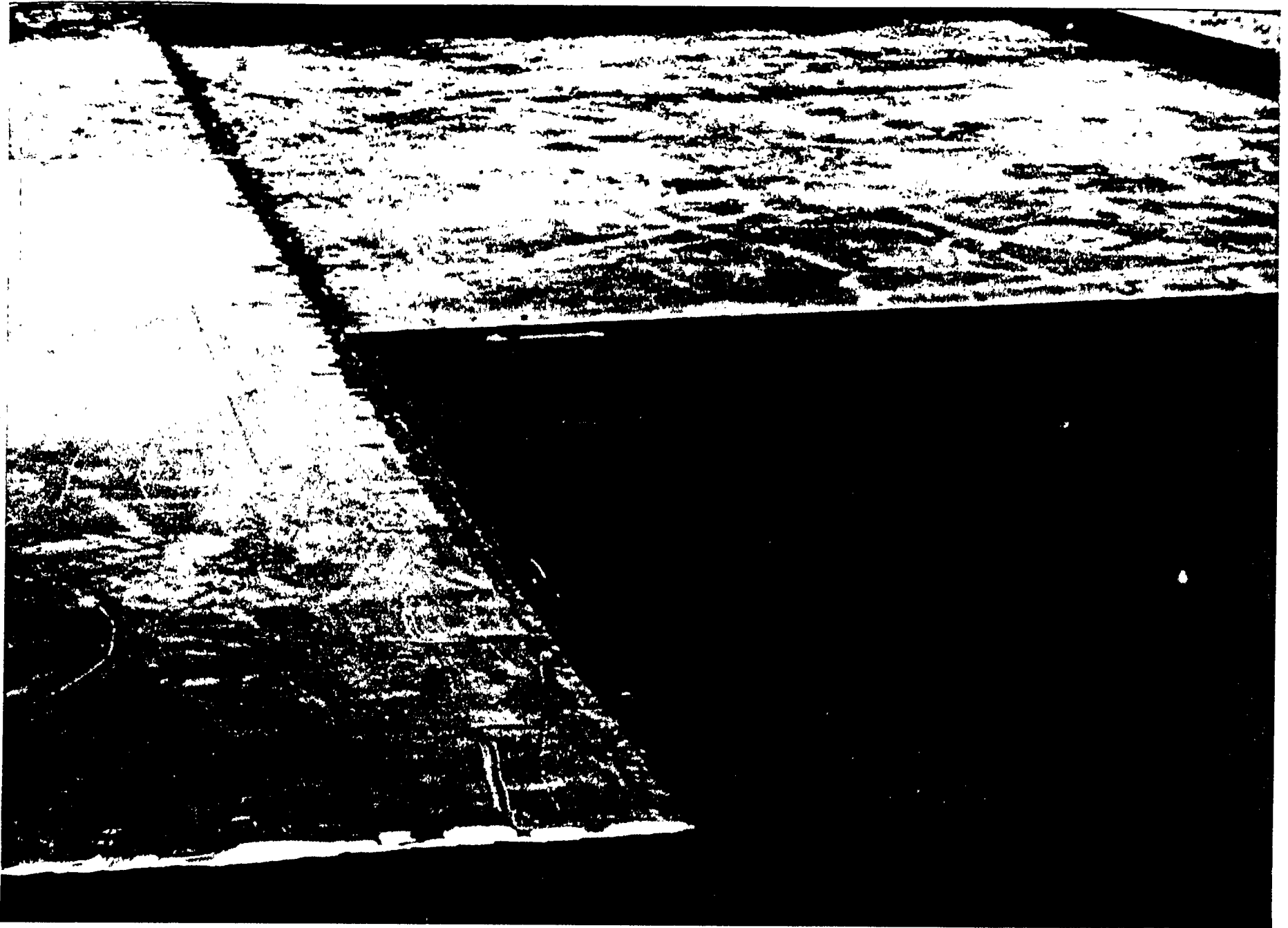

Fig. 37 Another close-up photograph of Cu/Ni - Fe/C weldment after grinding.

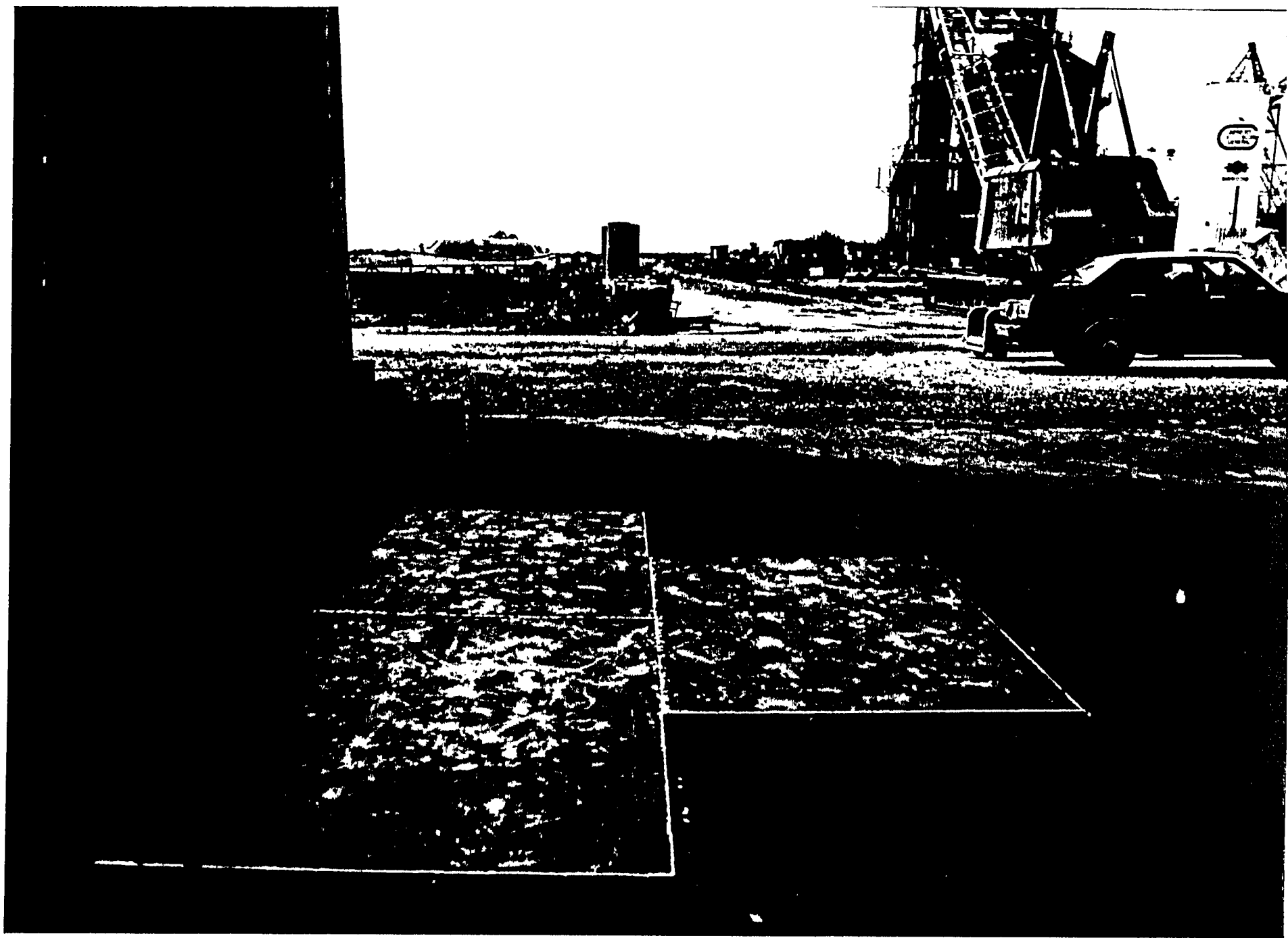

Fig. 38 An overview photograph of a completed Cu/Ni - Fe/C composite material used in the Final Laboratory Phase.

APPENDIX II

Technical Data and Information on the Respective Adhesives

(a) BOSTIK: M890 (Reactive Bonding System)

(a1) Product Description

Two part epoxy; M890 adhesive is applied to one of the surfaces to be bonded and spread by spatula or knife. The activator ("A" - general purpose type) is brushed on the other surface. The two surfaces are brought into contact as quickly as possible and clamped together for about three minutes to allow curing. Improperly placed components can be relocated within fifteen seconds. Thereafter disturbed bonds will be weakened. Excess cured adhesive can be trimmed off with a sharp knife. This two-part, no mixing type bonding system is tolerant to oily surfaces and is claimed to have high impact resistance.

(a.2) Physical Properties of M890 Bonding System

(a.2.1) Adhesive

Type	<b>Acrylic</b>
Color	<b>White to Yellow</b>
Viscosity	150-300 poises @ 77°F (25°C)
Solids Content	100% Polymerisable Liquid ,
Specific Gravity	1.02
Cleaner for Uncured Adhesive	Chlorinated Solvents or Toluol
Cleaner for Cured Adhesive	Tetrahydrofuran or a Sharp Knife
Flammability	Highly Flammable
Flash Point	90°F (32°C)
Storage	Below 77°F (25°C)

(a.2.1) Adhesive (cent. )

Shelf Life

12 Months @ 77°F or prolonged life  
if stored below freezing point.

**Health & Safety**

Cause irritation to eye or skin, so  
contact should be avoided. In the  
event of contact, use running water  
and soap. Avoid prolonged breathing  
of vapors.

(a.2.2) Activator "A"

Type

Reacted Amine

Color

Pale Brown

Viscosity

100 CPS @ 77°F (25°C)

Flammability

Non-Flammable

Storage

RT or below, dry place

(a. 3) Technical Data

TYPICAL BONDING PERFORMANCE USING ACTIVATOR A

SUBSTRATE	SHEAR BOND STRENGTHS	
	Psi	Kgf/cm <sup>2</sup>
<b>METALS</b>		
Steel (Solvent Wipe)	3300	232
Steel (Press Oil Coated)	2910	205
Aluminum (Solvent Wipe)	1900	134
Aluminum (Acid Etch)	4060	285
Copper	1300	91
Painted Steel (Heat Cured Acrylic)	2350	95
	2600	183
<b>PLASTICS</b>		
Formica Type	1700	120
GRP	1800 SF	127
GRP	1200 SF	84
Dylon	1600	112
Plexiglas	1300	91
Polycarbonate	2800	197
Polypropylene (Untreated)	170	12
PVC	2800 SF	197
<b>OTHERS</b>		
Beechwood	1450 SF	102
SBR (Untreated)	220 SF	15

SF - Substrate Failure

TYPICAL RATE OF BOND DEVELOPMENT AT 72-77°F. (22-25°C.)

MATERIAL	METHOD OF PREPARATION	SHEAR BOND STRENGTH - PSI (Kgf/cm <sup>2</sup> ) AFTER:							
		MINUTES					DAYS		
		3	5	10	15	30	60	1	3
Steel	Trichloroethylene Wipe	1120 ( 79)	1710 ( 120)	2580 ( 181)	2670 ( 188)	2930 ( 206)	3000 ( 211)	3300 ( 232)	3300 ( 232)
Steel	Oily (Press Oil)	890 ( 63)	1660 ( 117)	2000 ( 141)	2200 ( 155)	2540 ( 179)	2610 ( 184)	2800 ( 197)	2910 ( 205)
Aluminum	Trichloroethylene Wipe	530 ( 37)	1040 ( 73)	1430 ( 101)	1460 ( 103)	1620 ( 114)	1680 ( 118)	1700 ( 120)	1900 ( 134)
Aluminum	Chromic Acid Etch 30 Mins. @ 140°F.(60°C.)	1540 ( 108)	1900 ( 134)	2800 ( 197)	2820 ( 198)	3500 ( 246)	3660 ( 257)	4030 ( 283)	4060 ( 285)
Rigid PVC	Trichloroethylene Wipe	240 ( 17)	870 ( 61)	1500 ( 105)	2550 ( 109)	1680 ( 118)	2000 ( 141)	2800 (197 SF)	

SF - Substrate Failure

The rate of bond development is shown by cool ambient temperature but the ultimate bond strength is unaffected. Some scatter in bond strength is usual in the early bond ages but the ultimate strength varies only over a narrow range.

TYPICAL BOND CHARACTERISTICS: WATER RESISTANCE

SHEAR BOND STRENGTH - PSI (Kgf/cm <sup>2</sup> ) AT 73°F.(23°C.)							
MATERIAL	IMMERSED IN WATER AT 73°F.(23°C.)						
	1 WK	1 MTH	2 MTHS	3 MTHS	4 MTHS	5 MTHS	6 MTHS
Steel	2870 ( 202)	2490 ( 175)	2250 ( 158)	2050 ( 144)	2170 ( 153)	2060 ( 145)	2510 ( 176)
Aluminum Acid Etch	4050 ( 285)	3580 ( 252)	3290 ( 232)	3320 ( 233)	3450 ( 243)	3630 ( 255)	3580 ( 252)
IMMERSED IN WATER AT 185°F.(85°C.)							
Steel	2870 ( 202)	1120 ( 79)	750 ( 53)	600 ( 42)	120 ( 8.4)	110 ( 7.7)	907 ( 6.3)
Aluminum Acid Etch	3520 ( 247)	3180 ( 224)	2910 ( 205)	2730 ( 192)	2510 ( 176)	2710 ( 191)	2420 ( 170)

TYPICAL BOND CHARACTERISTICS: HEAT RESISTANCE

SHEAR BOND STRENGTH - PSI (Kgf/cm <sup>2</sup> ) AT 73°F.(23°C.)										
MATERIAL	EXPOSED AT 248°F.(120°C.)						EXPOSED AT 302°F.(150°C.)			
	1 WK	1 MTH	2 MTHS	3 MTHS	4 MTHS	5 MTHS	6 MTHS	1 WK	1 MTH	2 MTHS
Steel	1800 ( 127)	1200 ( 84)	700 ( 49)	500 ( 35)	500 ( 35)	500 ( 35)	360 ( 25)	1000 ( 70)	650 ( 46)	325 ( 23)
Aluminum Acid Etch	3360 ( 236)	3540 ( 249)	3270 ( 230)	2900 ( 204)	3025 ( 213)	3050 ( 214)	3270 ( 230)	3790 ( 266)	3650 ( 257)	2870 ( 202)

N.B. Fall-off in steel bond strengths due to corrosion of steel.

TYPICAL BOND CHARACTERISTICS: CHEMICAL RESISTANCE

MATERIAL	SHEAR BOND STRENGTH AFTER 10 DAYS IMMERSION IN:			
	ALUMINUM (ACID ETCH)		STEEL	
	PSI	(Kgf/cm <sup>2</sup> )	PSI	(Kgf/cm <sup>2</sup> )
Petrol	2700	( 190)	3650	( 257)
Mineral Oil	2750	( 193)	3850	( 271)
Mineral Oil (248°F. [120°C.])	1880	( 132)	3800	( 267)
Anti-Freeze	2850	( 200)	4000	( 281)
Ethanol	2550	( 179)	3350	( 236)
Acetone	560	( 39)	2900	( 204)
Toluene	2300	( 162)	3050	( 214)
Liquid Fluorohydrocarbon 3 mths at 32°F.(0°C.)	2450	( 172)	3020	( 212)

TYPICAL BOND CHARACTERISTICS: HUMIDITY RESISTANCE 100% R.H., 158°F. (70°C.)

SHEAR BOND STRENGTH - PSI (Kgf/cm <sup>2</sup> ) AT 73°F.(23°C.)					
MATERIAL	AFTER GIVEN EXPOSURE TIME				
	2 WKS	1 MTH	2 MTHS	3 MTHS	4 MTHS
Steel	2780 ( 195)	3140 ( 221)	2300 ( 162)	1850 ( 130)	1000 ( 70)
Aluminum Acid Etch	3580 ( 252)	3670 ( 258)	3450 ( 243)	3200 ( 225)	3100 ( 218)

**TYPICAL BOND CHARACTERISTICS: VARIATION OF SHEAR BOND STRENGTH WITH TEMPERATURE**

MATERIAL	METHOD OF PREPARATION	SHEAR BOND STRENGTH – PSI (Kgf/cm <sup>2</sup> ) AT:								
		-40°F. (-40°C.)	-4°F. (-20°C.)	32°F. ( 0°C.)	77°F. ( 25°C.)	167°F. ( 75°C.)	212°F. (100°C.)	257°F. (125°C.)	302°F. (150°C.)	347°F. (175°C.)
Steel	Trichloroethylene Wipe	1100 ( 77)	1475 ( 104)	2950 ( 207)	3050 ( 214)	2450 ( 172)	2200 ( 155)	1925 ( 135)	1075 ( 76)	300 ( 21)
Aluminum	Chromic Acid Etch 30 Mins. @ 122°F.(50°C.)	1775 ( 125)	2150 ( 151)	2700 ( 190)	3600 ( 253)	2750 ( 193)	2000 ( 141)	1475 ( 104)	1125 ( 79)	400 ( 28)

**TYPICAL BOND CHARACTERISTICS: EFFECT OF BOND THICKNESS**

Bond Thickness	Inches	0.005	0.010	0.020	0.030	0.040	0.050
	(mm)	(0.13)	(0.25)	(0.51)	(0.76)	(1.02)	(1.27)
Shear Bond Strength	PSI	2980	2890	2340	2020	1600	1050
Steel	(Kgf/cm <sup>2</sup> )	( 210)	( 203)	( 165)	( 142)	( 112)	( 74)

Setting time lengthens with increasing thickness. Activator should be applied to both mating surfaces, if possible, when bond exceeds 0.030" (0.76 mm). It is recommended that to achieve maximum bond strength thicknesses of 0.005–0.010" (0.13–0.25 mm) should not be exceeded.

**TYPICAL BOND CHARACTERISTICS: OPEN WORKING TIME**

BOND AGE	SHEAR BOND STRENGTH PSI (Kgf/cm <sup>2</sup> ) ZERO OPEN TIME	% ORIGINAL BOND STRENGTH RETAINED AFTER GIVEN OPEN TIME							
		ACTIVATOR OPEN TIME, HRS.				ADHESIVE OPEN TIME, HRS.			
		1	3	7	24	15	30	45	60
15 mins.	1900 ( 134)	95	75	60	60	95	60	60	60
1 hour	2660 ( 187)	95	95	95	80	95	95	80	80

This table shows that although the rate of bond development is reduced by increasing open times, the ultimate bond strength is almost unaffected.

**ADHESIVE MILEAGE**

Adhesive Thickness	Inches	0.001	0.002	0.004	0.005	0.0066	0.008	0.010
	(mm)	(0.02 )	(0.05 )	(0.10 )	(0.13 )	(0.17 )	(0.20 )	(0.25 )

**(1) Typical Area Coverage/U.S. Gallon – M890 Adhesive**

Area Coverage	Sq. Foot	1604	802	401	321	251	200	160
	(Sq. Meter)	( 194)	( 74.5)	( 37.3)	( 29.8)	( 23.3)	( 18.6)	( 14.9)

**(2) Typical Area Coverage/5 Litres – M890 Adhesive**

Area Coverage	Sq. Foot	2119	1059	530	424	331	265	212
	(Sq. Meter)	( 197)	( 98.4)	( 49.2)	( 39.4)	( 30.8)	( 24.6)	( 19.7)

**ACTIVATORS** On non-porous surfaces, an average of 1-3 grams Activator is sufficient to cover one square foot area (0.0920 square meters).

(b) 3M : EC-5354 Adhesive-Sealant

(b.1) Product Description

EC-5354 is a 100% solids tacky elastomer. It is available in sheets or rolls of up to 20" width and as thin as .03". Application requires the removal of the liner and sufficient pressure to assure good contact with a clean and dry surface. Fifteen ( 15) years of extensive service experience (not in shipbuilding, through) showed excellent durability and resistance to atmospheric conditions. There is no data available in bonding copper/nickel to ship hull steel. Approximate cost as of July 30, 1979 was \$1.80 per square foot.

(b.2) Physical Properties

Color	Black
Base	Synthetic Rubber
Consistency	Solid Rubber Extrusion
Solids	99% by weight
Specific Gravity	1.2 (approx. )

(b.3) Technical Data

Tensile Strength	8 psi
Tear Strength	4 psi
Adhesion to Concrete of a Copper Foil Laminant (14 days water soak)	No. Loss of Adhesion
Adhesion to FRP Fiberglass of Copper Foil Laminant (14 days water soak)	No Loss of Adhesion

(b .3) Technical Data (cont. )

Yield Strength

Initial 14.3-16.0 psi (Cohesive Failure)

3 Wks @ 100% RH, 100°F 16.5-16.9 psi (Cohesive Failure)

After 14 days water

soak 18.0 psi (Cohesive Failure)

Ozone Resistance

(72hrs. @ 150 ppm) No Change

Low Temperature

Flexibility (-20°F) No cracking when bead of sealer bent  
about a 1" mandrel

Storage Stability

Properties to remain unaffected when stored  
for 6 months at temperatures not  
exceeding 90°F.

Shelf Life (@ RT)

In excess of one year.

Surface Preparation

Max. sealing efficiency requires that  
the surfaces be clean , grease-free  
and dry.

Clean up

Excess sealer may be cut with a sharp  
knife or razor blade moistened with  
water.

(c) Armstrong Products, American Cyanamid, Adhesive Engineering

Since the candidate adhesives of these three companies did not provide satisfactory results in the "screening" tests, the technical data thereof is not included in this report.

The respective product ID numbers were as follows:

Armstrong	A-1 2RT
American	X- 10286 -480-2
Adhesive	Concrete 1380

All three products were of the two-part, premix, epoxy type.

**APPENDIX III**

THE CHARACTERIZATION OF COPPER-NICKEL / STEEL WELDMENTS

April 1980

Prepared by

Stephen M. Fisher

Asst. Prof. M. E.T.

West Virginia Tech

TABLE OF CONTENTS

List of Symbols	i
Abstract	1
Introduction	2
Mechanical Testing	4
Shear Tests	5
Modes of Weld Failure	7
Prediction of Failure Mode	10
Test Procedure	12
Test Results	13
Summary	20
Dynamic Tests	23
Test approach	26
Test Procedure	27
Test Results	31
Summary	40
Design Parameters	42
Metallurgical Weld Characterization	47
Sample Preparation	47
Weld Microstructure	52
Base Steel	52
Steel HAZ	52
Weld Metal	53

Base Copper-Nickel	53
Copper-Nickel HAZ	53
Microhardness	54
Test Procedure	55
Test Results	55
Microstructure of Failure Areas	58
Static Failure	58
Fatigue Failure ( CU-Ni HAZ )	58
Fatigue Failure (Weld Metal)	59
Conclusion	60
Bibliography	62
Appendix A	
Load-Strain Diagrams	
Appendix B	
Photographs of Static Failures	
Appendix C	
Photographs of Fatigue Failures	
Appendix D	
SEM Fractographs of Weld Fatigue Failure	
Appendix E	
Photomicrographs	

## CONCLUSIONS

The shear strength of the weldments, both slot and butt welds, exceeds the tensile strength of the base copper-nickel for 10 inch plate. The tensile rupture strength of the copper-nickel at the weld, owing to stress concentrations, is less than the ultimate strength of the base metal. A mean strength reduction factor of .80 for the slot welds and .90 for the butt welds may be applied to the base metal to obtain nominal tensile strength values for the copper-nickel in the immediate weld area.

The fatigue properties of the weldments are below the base copper-nickel fatigue properties. This is due to geometrical stress concentrations, especially at the "crack like discontinuity", and metallurgical stress raisers from the welding process.

Fatigue failure occurred primarily in the copper-nickel HAZ, initiating in the area of the "crack like discontinuity." The microstructure in this area is dendritic solidification structure, bounded by the wrought copper-nickel structure with "melting" at the grain boundaries.

A weld fatigue reduction factor of .63 was obtained from the fatigue data with the use-of the Solderberg criterion. This would establish the weld failure endurance limit at a stress of 20 Ksi in the steel. However, the fatigue testing was performed at only one load level and a program of additional testing needs to be undertaken before any design criterion could be established.

The addition of an adhesive bonding between the copper-nickel and steel resulted in a lower fatigue stress in the weld area, with improved fatigue performance.

The fatigue failure in the weld metal/steel resulting from a weld "defect" suggests that in addition to a comprehensive mechanical test program a weld defect tolerance study also be undertaken.

NOTE

by

L. W. SANDOR

FOR FULL DETAILS, THE READER  
IS REFERRED TO THE COMPLETE  
REPORT (114 PAGES) BY FISHER.