

SHIP PRODUCTION COMMITTEE
FACILITIES AND ENVIRONMENTAL EFFECTS
SURFACE PREPARATION AND COATINGS
DESIGN/PRODUCTION INTEGRATION
HUMAN RESOURCE INNOVATION
MARINE INDUSTRY STANDARDS
WELDING
INDUSTRIAL ENGINEERING
EDUCATION AND TRAINING

October 22, 1999
NSRP 0551
N1-96-2

THE NATIONAL SHIPBUILDING RESEARCH PROGRAM

Contaminated Sediment Management Guide for NSRP Shipyards Appendix 4: Removal Technologies

U.S. DEPARTMENT OF THE NAVY
CARDEROCK DIVISION,
NAVAL SURFACE WARFARE CENTER

in cooperation with
National Steel and Shipbuilding Company
San Diego, California

Report Documentation Page

Form Approved
OMB No. 0704-0188

Public reporting burden for the collection of information is estimated to average 1 hour per response, including the time for reviewing instructions, searching existing data sources, gathering and maintaining the data needed, and completing and reviewing the collection of information. Send comments regarding this burden estimate or any other aspect of this collection of information, including suggestions for reducing this burden, to Washington Headquarters Services, Directorate for Information Operations and Reports, 1215 Jefferson Davis Highway, Suite 1204, Arlington VA 22202-4302. Respondents should be aware that notwithstanding any other provision of law, no person shall be subject to a penalty for failing to comply with a collection of information if it does not display a currently valid OMB control number.

1. REPORT DATE 22 OCT 1999	2. REPORT TYPE N/A	3. DATES COVERED -			
4. TITLE AND SUBTITLE The National Shipbuilding Research Program, Contaminated Sediment Management Guide for NSRP Shipyards Appendix 4: Removal Technologies		5a. CONTRACT NUMBER			
		5b. GRANT NUMBER			
		5c. PROGRAM ELEMENT NUMBER			
6. AUTHOR(S)		5d. PROJECT NUMBER			
		5e. TASK NUMBER			
		5f. WORK UNIT NUMBER			
7. PERFORMING ORGANIZATION NAME(S) AND ADDRESS(ES) Naval Surface Warfare Center CD Code 2230-Design Integration Tools Bldg 192, Room 128 9500 MacArthur Blvd Bethesda, MD 20817-5700		8. PERFORMING ORGANIZATION REPORT NUMBER			
9. SPONSORING/MONITORING AGENCY NAME(S) AND ADDRESS(ES)		10. SPONSOR/MONITOR'S ACRONYM(S)			
		11. SPONSOR/MONITOR'S REPORT NUMBER(S)			
12. DISTRIBUTION/AVAILABILITY STATEMENT Approved for public release, distribution unlimited					
13. SUPPLEMENTARY NOTES					
14. ABSTRACT					
15. SUBJECT TERMS					
16. SECURITY CLASSIFICATION OF:			17. LIMITATION OF ABSTRACT SAR	18. NUMBER OF PAGES 148	19a. NAME OF RESPONSIBLE PERSON
a. REPORT unclassified	b. ABSTRACT unclassified	c. THIS PAGE unclassified			

DISCLAIMER

These reports were prepared as an account of government-sponsored work. Neither the United States, nor the United States Navy, nor any person acting on behalf of the United States Navy (A) makes any warranty or representation, expressed or implied, with respect to the accuracy, completeness or usefulness of the information contained in this report/manual, or that the use of any information, apparatus, method, or process disclosed in this report may not infringe privately owned rights; or (B) assumes any liabilities with respect to the use of or for damages resulting from the use of any information, apparatus, method, or process disclosed in the report. As used in the above, "Persons acting on behalf of the United States Navy" includes any employee, contractor, or subcontractor to the contractor of the United States Navy to the extent that such employee, contractor, or subcontractor to the contractor prepares, handles, or distributes, or provides access to any information pursuant to his employment or contract or subcontract to the contractor with the United States Navy. ANY POSSIBLE IMPLIED WARRANTIES OF MERCHANTABILITY AND/OR FITNESS FOR PURPOSE ARE SPECIFICALLY DISCLAIMED.

Index of Removal Technologies

Technology Name	Technology Category
American Mechanical Dredge, Floating Clamshell Dredge	Mechanical
Aquamec Ltd., Watermaster	Mechanical
Aquarius Systems, Amphibious Excavator	Hydraulic
Aquatics Unlimited, Aquamog	Hydraulic
Aztec Development Co., JET-SPRAY Thin-Layer Dredged Material Disposal	Hydraulic
Baggermaatschappij Boskalis B.V., Horizontal Closing Environmental Grab	Mechanical
Bean Technical Excavation Corp., BONACAVOR with Slurry Processing Unit	Mechanical, Hydraulic
Bedrock Resources Inc., REACT Dredging System	Hydraulic, Fluidization
Cable Arm (Canada) Inc., Cable Arm Clamshell Bucket	Mechanical
Conbar International, Environmental Dredger	Hydraulic
Consolidated Dewatering Inc., Dewatering	Hydraulic
CP Environmental Inc., Non-Resuspension of Solids During Subaqueous Removal	Hydraulic
Dosco klein Baggerwerken B.V., Scraper Dredge	Miscellaneous
Dredging International, Scoop Dredge BRABO	Hydraulic
Dredging Specialists, Hydraulic Dredges	Hydraulic
Dredging Supply Company, Barracuda/Piranha/Shark	Hydraulic
Eagle Iron Works, Swintek Dredge Ladder	Mechanical, Hydraulic
Ellicott Internation, Mudcat	Hydraulic
Eriksson Sediment Systems, Inc., Method for Marine Sediment Removal, Dewatering	Miscellaneous
HAM, Visor Grab	Mechanical
Harbour Development, Dredges	Mechanical, Hydraulic

Index of Removal Technologies

Technology Name	Technology Category
Honma Corporation, No. 1 Water Refresher (High Density Dredging System)	Hydraulic
Honma Corporation, Water Refresher HD-110	Hydraulic
IHC Holland N.V., Environmental Dredger	Miscellaneous
LWT Inc., Liquid Waste Technology Inc., Pit Hog Dredges	Hydraulic
Nautilus Dredging and Docks, STUMP	Hydraulic
Normrock Industries Inc., Amphibex	Mechanical, Hydraulic
Penta-Ocean, Pneumatic Type Sand Pressurized Feeding Ship (GOSEI GO)	Pneumatic
Penta-Ocean, SWAN Method	Mechanical
Pneuma Hydraulic Dredge	Pneumatic
Pneuma s.r.l./IME Ltd., Underwater Dredging Pump	Pneumatic
Pressair International Corp., Airlift Systems	Hydraulic, Pneumatic
Rinkai Construction Co. Ltd, Pulse Air Type High Density Sludge Transport Ship	Pneumatic
Rinkai Construction Co. Ltd, Screw Conveyor Type Mud Collector	Mechanical
Saeki Kensetsu Kogyo Co. Ltd., No. 1 Mud Cleaner	Hydraulic
Saeki Kensetsu Kogyo Co. Ltd., Screw-Feeder-Type Air-Pressuring Ship (Hakuryo)	Hydraulic
Saeki Kensetsu Kogyo Co. Ltd., Tank Type Air Pressurizing Method (Nos. 1,2, & 5)	Pneumatic
Sanexen, Vacuum Clam Dredge	Mechanical, Hydraulic
Sevenson Environmental, Hydraulic Cutter	Hydraulic
Soli-Flo, Eddy Pump Technology	Hydraulic
SRS Crisafulli, Rotomite 180P	Hydraulic
Toa Corporation, High Density Sludge Transport System Method (TOTRA)	Miscellaneous

Index of Removal Technologies

Technology Name	Technology Category
Toa Corporation, IRIS Method	Mechanical
Toa Corporation, No. 7 Clean-Up Dredger	Hydraulic
Toyo Construction, Floating Pier Reclamation Method	Miscellaneous
Toyo Construction, Oozer-Pump Dredging Method	Hydraulic
Wakachiku Construction, "No. 2 Clean Sweeper" High-Density Sludge Dredger	Hydraulic
Wartsila Scraping Dredger	Mechanical
Youngsman, Weed and Sedimentation Removal	Hydraulic, Fluidization

American Mechanical Dredge, Floating Clamshell Dredge

11-Dec-97

TECHNICAL REPORT

Technology Type: Mechanical

System Works With: Limited Shore Access

Can remove solids without removing water

Development Stage: Commercial

Country Of Origin: Germany

Description:

Floating Clamshell Dredges are used to dredge out areas that cannot be reached with suction type dredges. The Clamshell can operate at depths down to 60 m or greater. Also is used to maximize the solids concentration without removing large volumes of water.

Limitations: Normally not used in small areas.

Type of Power:

Government Funding:

Environmental Concerns:

Health & Safety Plan Available:

Regulatory Approvals

Setup/Feed:	Mobilization (days):	Demobilization (days):
	Removal Rate Average (m³/hr): 235	
Cost:	Capital Cost (US\$): \$500,000.00	
	Unit Cost (US\$/m³): \$3.50 – \$6.00	Average Cost (US\$/m³): \$4.50

Developers:

P.S. Forder-Und Lagertechnik GMBH
Rotterdammer Strabe 15
Mannheim,
Germany 68219-
Notes

Contact: Engemann, Bernd
Phone: 011496218905295 **Ext:**
Fax: 011496218905269
Email: Dredge@NC5.INFL

Vendors:

American Mechanical Dredge
P.O.B. 358
Mt. Juliet, TN
USA 37122-
Notes

Contact: Henry, Morris
Phone: (615) 754-5464 **Ext:**
Fax: (615) 754-5467
Email:

Literature References:

American Mechanical Dredge, Floating Clamshell Dredge

11-Dec-97

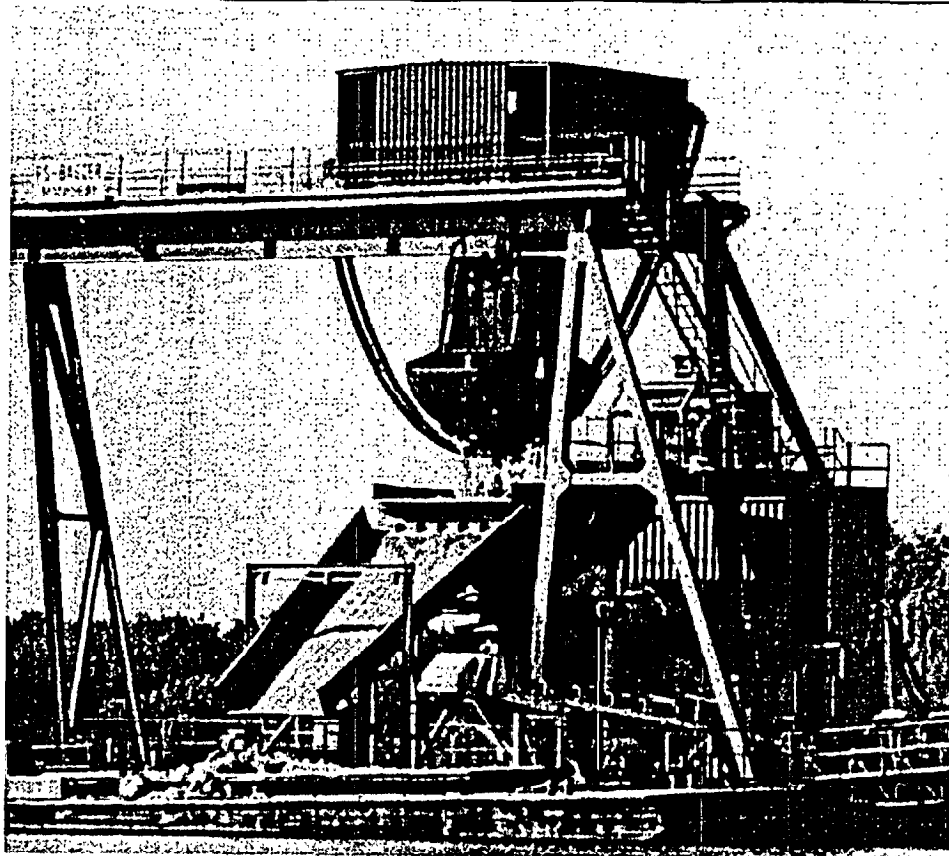

Technology Type: Mechanical, Fluidization

System Works With: Debris, Water Depth 2-10m

Development Stage: Commercial

Country Of Origin: Finland

Description:

- Watermaster Classic II A Backhoe dredger
- II B Pumping Bucket Dredger
- II C Cutter Pump Dredger

Watermaster RS 2000 Harvester

TECHNICAL SPECIFICATIONS:

Engine: Volvo TD 610 M, turbo-charged, water-cooled, 6-cylinder diesel engine.

- flywheel power 118 kW at 2000 rpm
- fuel tank capacity 1200 l
- electric system 24 V
- batteries 2 at 158 Ah

Hydraulics: 2 axial piston pumps:

- dredging and propeller 75 ccm/rev
- max. operating pressure 300 bar
- excavator arm and stabilizers 71 ccm/rev
- max. operating pressure 210 bar

Excavator (w. 400 l (SAE) back-hoe bucket):

- Swinging angle 180 °
- Max. reach 7.45 m
- Digging Depth 4.3 m
- Dumping height 4.0 m
- Break-out force (from bucket cylinder) 77 kN
- Digging force (from arm cylinder) 40 kN
- Lifting capacity at max. reach 16 kN

Stabilizers:

- Max. stabilizing depth
- front 2.5 m
- rear 4.9 m
- Detachable floats for the front stabilizers
- stabilizing depth with floats 2.5 m
- Rear stabilizers
- size 200 mm x 200 mm
- cylinder stroke 1500 mm

Noise and vibration emissions, according to directive 96/662/EEC

- sound power level: L (WA) = 105 dB re 1 pW
- sound pressure level at the operators position: 1 = 74 dB re 20 µPa
- the whole-body vibration, according to standard ISO 2631/1-1985 (E), does not exceed 0.5 m/s²

Limitations: Digging depth 4.2 m; Max. reach 7.1 m.

Type of Power: Diesel-Hydraulic

Government Funding:

Environmental Concerns:

Health & Safety Plan Available:

Regulatory Approvals

Setup/Feed: Mobilization (days):

Demobilization (days):

Removal Rate Average (m³/hr): 55

Cost: Capital Cost (US\$):

Unit Cost (US\$/m³): \$1.30 - \$2.50

Average Cost (US\$/m³): \$1.90

Developers:

Aquamec Ltd.
P.O.B. 260
Iso-Vimma,
Finland FIN-27821
Notes

Contact: Kuusisto, Martti
Phone: 358383974500 Ext:
Fax: 358383974522
Email:

Vendors:

Aquamec Ltd.
P.O.B. 260
Iso-Vimma,
Finland FIN-27821
Notes

Contact: Kuusisto, Martti
Phone: 358383974500 Ext:
Fax: 358383974522
Email:

Literature References:



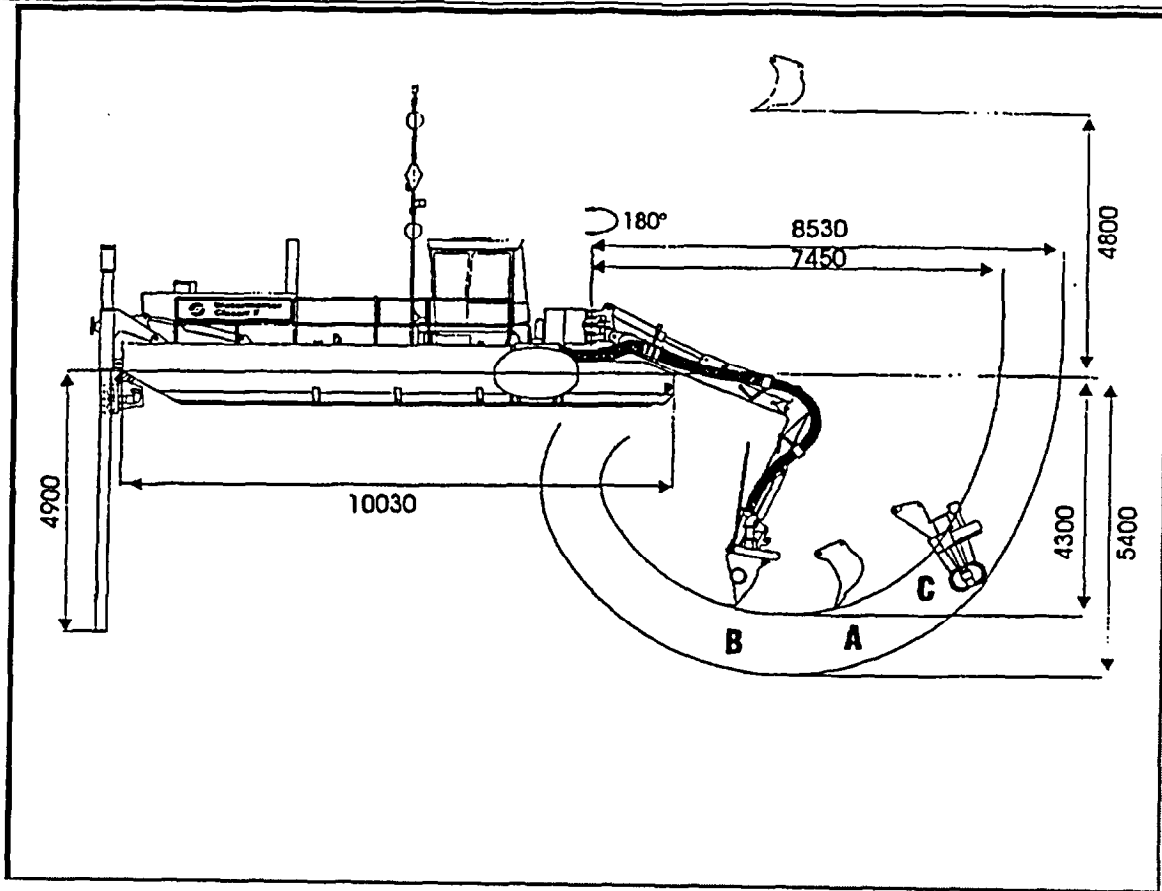

Aquarius Systems, Amphibious Excavator

11-Dec-97

TechID: 342

Technology Type: Hydraulic

System Works With: Debris, Water Depth 2-10m, Limited Shore Access

Development Stage: Commercial

Country Of Origin: USA

Description:

The Aquarius Amphibious Excavator is a barge-mounted backhoe capable of turning 360°. The unit operates in up to 4 m of water, but optimally performs best in up to 2.5 m of water. The Amphibious Excavator allows the operator to work in areas where traditional equipment cannot work, such as lakes, swamps, bogs, etc. This unique heavy-duty amphibious dredger consists of a specially adapted excavator fitted to a three legged barge. The legs end in pairs of large hollow cylindrical wheels. Power from the four cylinder diesel engine enables the machine to move hydraulically by using the jib, dipper, slew, and bucket.

Limitations: The unit operates in up to 4 m of water, but optimally performs best in up to 2.5 m of water.

Type of Power: Diesel engine, Hydraulic controls

Government Funding:

Environmental Concerns:

Health & Safety Plan Available:

Regulatory Approvals

Setup/Feed:	Mobilization (days):	Demobilization (days):
	Removal Rate Average (m³/hr): 20	
Cost:	Capital Cost (US\$): \$99,500.00	
	Unit Cost (US\$/m³): -	Average Cost (US\$/m³):

Developers:

Aquarius Systems

P.O.B. 215, 220 N. Harrison St.
North Prairie, WI
USA 53153-0215
Notes Nell Register: <http://www.nell.com>

Contact:

Phone: (414) 392-2162 **Ext:**
Fax: (414) 392-2984
Email: Aquarius_Weedeater

Vendors:

Aquarius Systems

P.O.B. 215-220 N. Harrison St.
North Prairie, WI
USA 53153-
Notes Nell Register: <http://www.nell.com>

Contact: Dauffenbach, Jane

Phone: (414) 392-2162 **Ext:**
Fax: (414) 392-2984
Email: Aquarius_Weedeater

Literature References:

Aquarius Systems, Amphibious Excavator

11-Dec-97

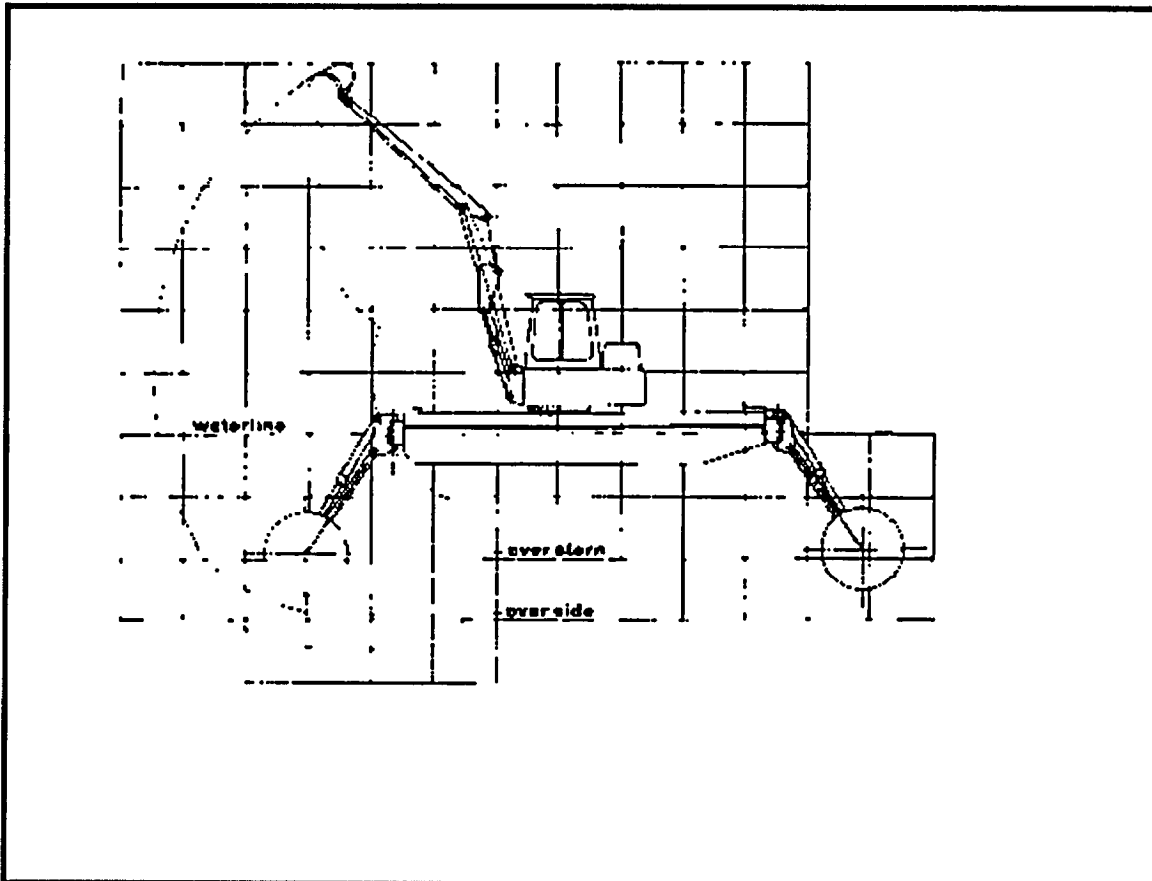
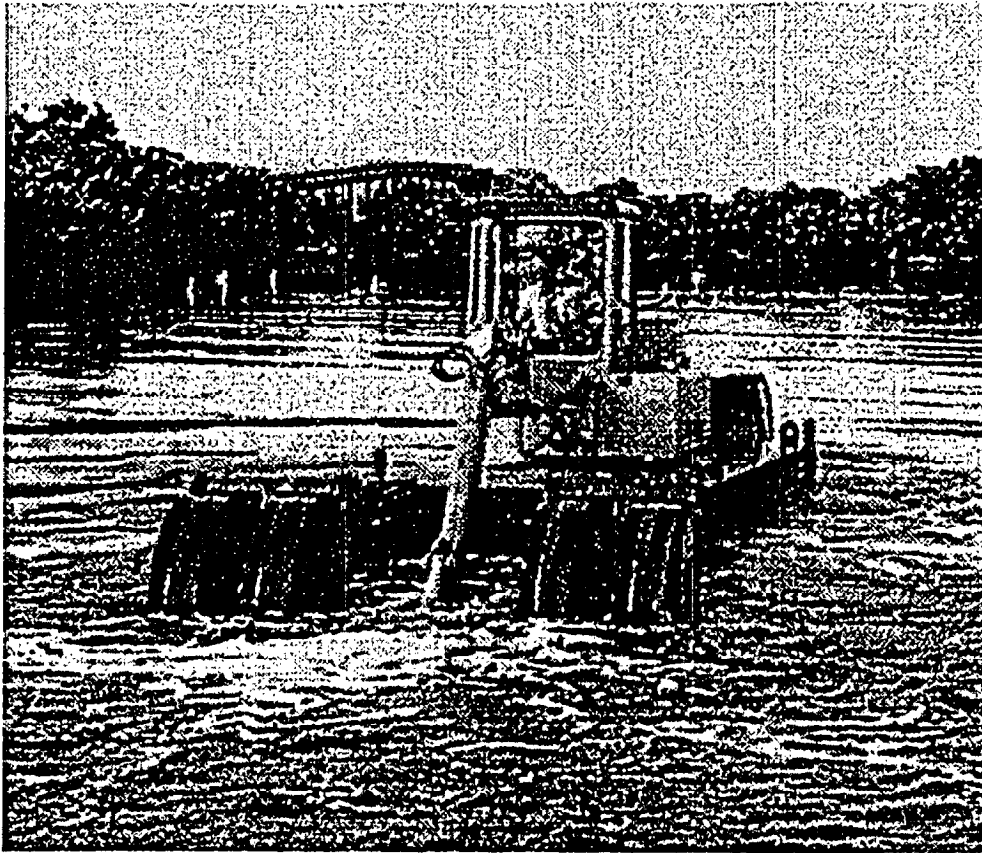

Aquatics Unlimited, Aquamog

11-Dec-97

TechID: 267

Technology Type: Hydraulic

System Works With: Debris, Water Depth 2-10m

Development Stage: Commercial

Country Of Origin: USA

Description:

The Aquamog is a multi-purpose aquatic ecosystem creation, restoration and maintenance vessel-economy and transportability combined.

The Aquamog's excavating arm can reach a depth of more than 6 m, a height of 6 m, and swings a minimum of 180 degrees. It has the capacity for quick tool exchange that allows for interchangeability from hydraulic to bucket dredging in a matter of minutes.

The Aquamog can perform pond, lake, reservoir, canal, marsh or wetland maintenance requirements. It can perform functions ranging from bucket/suction dredging to submerged/emergent aquatic weed control using interchangeable attachments. Standard attachments range from clam/digging buckets to hydraulic cutter/auger heads for dredging and flail/sickle mowers to rototillers and rakes for aquatic weed control.

Aquatics Unlimited produces a line of shallow draft/multi-purpose vessels that perform functions ranging from debris/oil cleanup to bucket/suction dredging to emergent/submergent aquatic plant control using interchangeable attachments. The dredges are available with cutterheads or shrouded augers depending on the type of material to be dredged and job specific requirements. The working capacity of the dredges range from 45 m³/hour with the 20 cm plant.

Aquatics Unlimited dredges are offered with a variety of suction attachments that allow low turbidity/high solids output as well as agitation dredging apparatus. They are small portable dredges that work well in marinas for slip and channel maintenance where a small dredge is required to dredge small volumes near docks.

Limitations: Aquatics Unlimited dredges are largely limited to smaller projects within their production capability.

Type of Power:

Government Funding:

Environmental Concerns:

Health & Safety Plan Available:

Regulatory Approvals

Setup/Feed: Mobilization (days):
Removal Rate Average (m³/hr): 55

Demobilization (days):

Cost: Capital Cost (US\$):
Unit Cost (US\$/m³): \$3.50 - \$4.60 Average Cost (US\$/m³): \$4.00

Developers:

Aquatics Unlimited
2150 Franklin Canyon Road
Martinez, CA
USA 94553-
Notes

Contact: Gahring, Tim
Phone: (510) 370-9175 Ext:
Fax: (510) 370-9179
Email:

Vendors:

Aquatics Unlimited
2150 Franklin Canyon Road
Martinez, CA
USA 94553-
Notes

Contact: Gahring, Tim
Phone: (510) 370-9175 Ext:
Fax: (510) 370-9179
Email:

Literature References:

Aztec Development Co., JET-SPRAY Thin-layer Dredged Material Disposal

11-Dec-97

TechID: 302

Technology Type: Hydraulic

System Works With: Debris, Strong Currents, Water Depth 2-10m, Limited Shore Access
Light debris

Development Stage: Commercial

Country Of Origin: USA

Description:

Summary: Placement of well-slurried contaminated material in thin layers over wide areas of less than 8 cm onto existing vegetation using aerial spray techniques via continuously moving nozzles for vegetative uptake of toxins for subsequent harvesting and disposal. Placement of noncontaminated material in thin-layers nourishes existing saltwater marshes and wetlands, or provides new marsh construction of beach nourishment. Dredged material can be hydroseeded.

Description: Capable of reducing costs as much as 90 percent, while providing more effective, more efficient, and ecologically safer results than conventional systems for shallow and/or narrow waterways, the Jet-Spray® method incorporates a new combination of innovative mechanical developments. All its elements work together to allow continuous excavation on a straight and narrow fixed path. Completely independent, Jet-Spray® equipment has no fixed-terrain attachments; it eliminates all need for or use of items such as anchors, dredge pipes, cables, spuds, spoil ponds, berms or hopper-bergs dumping. Two variations are designated Water-Vac and Water-Weeder -- both designed specifically to reduce costs and environmental damage in areas of heavy vegetation infestations, or excavating requiring minimal turbidity.

The Jet-Spray® method is designed for shallow-draft operation. The floating, self-propelled Jet-Spray® dredge and spoil disperser has a depth-adjustable cutterhead of multiple horizontal augers. The cutterhead features 100 percent excavating action across its entire face, to create a box-section cut deeper and wider than flotation requirements, even into uplands. Each horizontal auger has a toothed flange which closely intersects with adjacent auger axes, providing self-cleaning action.

The cutterhead finely slurries spoil, which next is pressurized by a conventional dredge pump, then further slurried at the pump impeller by internal shear-action knives. Next, pressurized slurry is pumped to directable accelerator nozzles that are controlled in both vertical and horizontal planes and sized for varied types of slurry and distribution. As the dredge moves forward, the accelerator nozzles air-jet slurried spoil to each side of the dredge - up to 60 m per side - obtaining the thinnest practicable overlay pattern. This pattern also is controlled by adjustable water-column diffusion, nozzle-tip inserts. Air-jetted spoil is sprayed in the form of a soft mist falling like rain, and distributed widely for minimal environmental damage.

Self-propulsion, steering and cutterhead thrust are provided via jet thrust reactions of the two opposing-side accelerator nozzles. Single-side air-jet spoil disposal also is possible by using a counterbalancing underwater bow-thruster. Occasionally, a push-boat for additional thrust and steering is desirable and, for special situations, a cable winch-anchor propulsion system is available.

Where Jet-Spray® spraying alongside a channel or in open water is not appropriate, material can be pipelined to a remote area and then Jet-Spray®-ed to a convenient location via land-based Jet-Spray® remote units.

Limitations: Requires wide areas of suitable seasonal level vegetation with small berm enclosures to contain possible runoff. 80 m maximum from nozzle spread; no rock or high plastic clay.

Type of Power: Diesel Pumps

Government Funding:

Environmental Concerns: Runoff and spray disapportions by wind. Turbidity monitoring.

Health & Safety Plan Available:

Regulatory Approvals Dredge and Fill Permit. U.S. Army Corps of Engineers, U.S. fish & Wildlife Service, U.S. Environmental Protection Agency, Louisiana Dept. of Environmental Regulation, and various other U.S. states. Jet-Spray® is a Registered Trademark and a proprietary system. Jet-Spray® is protected by U.S. Patent Numbers: 4,759,664; 4,896,445; 5,211,511; 5,167,469; 3,971,148; 4,628,623; 4,434,943; 4,575,960; 4,517,754; 4,240,243; and 4,521,305. Patents have also been issued for various countries with some other foreign patents pending. U.S. Patents are insured by The Homestead Insurance Company for Patent Infringement Abatement Insurance.

Setup/Feed: Mobilization (days):

Demobilization (days):

Removal Rate Average (m³/hr): 100

Cost: Capital Cost (US\$):

Unit Cost (US\$/m³): \$4.45 - \$5.00

Average Cost (US\$/m³): \$4.50

Assumed dredging volume of 26,160 m³ (not 20,000 m³). Capital cost: Lease.

Developers:

Aztec Development Co., JET-SPRAY Thin-layer Dredged Material Disposal

11-Dec-97

Aztec Development Co.
1331 W. Central Blvd.
Orlando, FL
USA 32805-
Notes

Contact: Deal Jr., Troy M.
Phone: (407) 849-6420 Ext:
Fax: (407) 841-9416
Email:

Vendors:

Aztec Development Co.
1331 W. Central Blvd.
Orlando, FL
USA 32805-
Notes

Contact: Deal Jr., Troy M.
Phone: (407) 849-6420 Ext:
Fax: (407) 841-9416
Email:

Literature References:

- Author: Deal, Troy
Title: Jet-Spray, Water-Weeder, and Water-Vac: New Economically Superior, Ecologically Advantageous Methods for Shallow
Journal: and/or Narrow Waterway Maintenance Dredging and Dredged Material Disposal
Date:
- Author: Cahoon, D.R., Cowan, J.H.
Title: Environmental Impacts and Regulatory Policy Implications of Spray Disposal of Dredged Material In Louisiana Wetlands
Journal: Coastal Management, Vol. 16, pp 341-362. Date: Jan 1988
- Author: Richardson, S. (Ed.)
Title: Mississippi Delta Rehab Project, Aerial Placement of Dredged Material
Journal: World Dredging Mining & Construction Date: Aug 1992
- Author: Wilbur, P., Luczdovich, J., Knowles, D.
Title: The Long-Term Environmental Effects of Thin-layer Disposal on a Salt Marsh, Lake Landing Canal, NC
Journal: World Dredging Mining & Construction Date: Aug 1992
- Author: Richardson, S. (Ed.)
Title: City of Savannah's 14-Year Environmental Problem Solved
Journal: World Dredging Mining & Construction Date: Aug 1993
- Author: Deal, Troy
Title: Jet-Spray Thin-Layer Overlays of Dredged Material for Wetlands Rehabilitation and Creation
Journal: Proceedings of the Second Annual Marine and Estuarine Shallow Water Science and Management Conference Date: Jan 1995

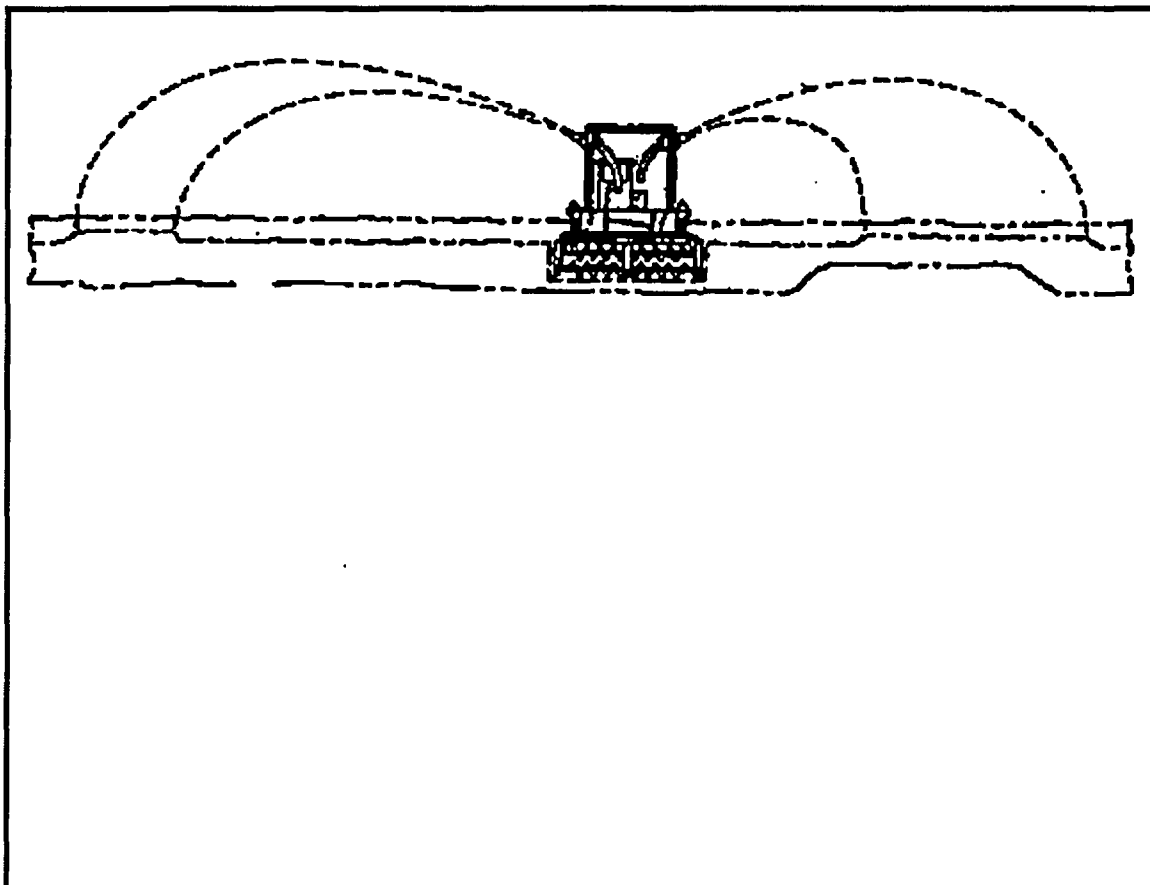

Aztec Development Co., JET-SPRAY Thin-layer Dredged Material Disposal

11-Dec-97

Project: Mississippi Delta Rehabilitation

Year 92

Location: Plaquemines Parish, LA, USA

Full Scale Demo

Client/Funding Agency	Contact	Phone
US EPA US Fish & Wildlife Service		

Not Monitored

Removal Rate(m³/hr): 100 Amount Removed In-Situ (m³): 50000

Removal Cost(US\$): \$350,000.00

Mobilization (days): 14 Demobilization (days): 7

Site Conditions: Still water, 30 cm deep, 1.3 m silt & vegetation removal.

Contaminants Present: None

Water Quality: Turbid

Turbidity: No increase relative to background conditions.

Total Suspended Solids:

Percent Solids:

Site Containment Used? No Yes

Exceed Set Standards?

Description: Two Fresh Water Diversion Projects for the Rehabilitation of the Mississippi Delta undertaken for Plaquemines Parish, Louisiana Government. The project was designed to divert sediment-laden water from the Mississippi River into west bank wetlands to offset saltwater intrusion and land subsidence. The outfall channels were mandated in the contract specifications to be of Jet-Spray construction only due to Jet-Spray's ability to place dredged material without creating typical waterflow impediments such as berms, containment ponds, or border levels. Through use of the Jet-Spray aerial placement of dredged material method, the dredged outfall channel material was able to be aerielly projected in thin-spray overlays, thereby imitating the original thin-flood deposits that invigorate rather than smother marsh grasses. The use of a small swinging-ladder travelling-spud Jet-Spray dredge also reduced marsh loss, due to its ability to cut a channel width of 5 m without causing marsh destruction from anchors, cables, and pipelines.

Project: Abercorn Creek Dredging for City of Savannah, GA

Year 92

Location: Savannah, Georgia, USA

Full Scale Demo

Client/Funding Agency	Contact	Phone
City of Savannah, Georgia	John Sawyer, City Engineer	(912) 651-6510

Not Monitored

Removal Rate(m³/hr): 100 Amount Removed In-Situ (m³): 15000

Removal Cost(US\$): \$180,000.00

Mobilization (days): 5 Demobilization (days): 2

Site Conditions: High velocity, flood water, 1 m deep, sand & clay

Contaminants Present: None

Water Quality: Turbid

Turbidity: Low (relative to background conditions).

Total Suspended Solids: Low

Percent Solids: Not measurable.

Site Containment Used? No Yes

Exceed Set Standards? Yes—Overlays less than 8 cm.

Description: For 14 years the City of Savannah tried to obtain permits to improve their potable water supply from the nearby Little Abercorn Creek- but due to environmental concerns of the creek flowing through a U.S. Fish & Wildlife Freshwater Hardwood Wetlands Preserve, permits were unobtainable using conventional dredging methods. As a result, the City's water quality and supply deteriorated, and extra silt-treatment work was costing the City thousands of dollars annually. After careful research, environmental scientists concluded that by using the patented Jet-spray aerial placement of dredge material method they could meet their stringent requirements - and permitting was obtained. Initial contractor inspection disclosed a 30-60 cm deep by 3.3-4 m wide, shallow, ill-defined and overgrown creek, and the dredged material was to be placed through a wall of hardwood trees into a wetlands area with a maximum of 8 cm final overlays. The project was especially difficult since the material turned out to be nonslurrying sand and extremely plastic clay, with all kinds of trees, stumps, and obstructions normally associated with new construction in a swamp. Through the use of Jet-Spray, the project was finished ahead of schedule and all objectives and environmental concerns were met which resulted in the creation of a new 3 m deep, 3.3 m-wide bottom, and 10 m - wide top river. Jet-Spray accomplished the City's purposes and also satisfied the U.S. Fish & Wildlife Service. A 90-day follow-up inspection was conducted by the Corps of Engineers to determine the recovery of affected areas and showed very little evidence that Jet-Spray dredging had even been in the

Aztec Development Co., JET-SPRAY Thin-layer Dredged Material Disposal

11-Dec-97

area- one had to literally get onshore to find any evidence of Jet-Spray overlays. The leaves were all on the trees, the vegetation was growing, and all-in-all the Corps of Engineers and regulatory agencies representatives were extremely pleased.

Baggermaatschappij Boskalis B.V., Horizontal Closing Environmental Grab

19-Dec-97

TechID: 285

Technology Type: Mechanical

System Works With: Debris, Water Depth 2-10m

Development Stage: Commercial

Country Of Origin: The Netherlands

Description:

The horizontal closing environmental grab is a specially designed hydraulic clam which closes in a horizontal plane. Due to this feature it is possible to dredge layers of contaminated sludge with a high accuracy and efficiency. Other gadgets are:

-- a detection system which indicates that the bucket is closed, just to prevent any leakage.

-- a navigation and depth measuring system to allow accurate dredging. A venting system at the top of the bucket allows water and air to evacuate by descending.

The horizontal closing environmental grab has a mouth 80% greater than traditional buckets, although to fill a bucket with a capacity of 2 m³ the dredged layer is only 29 cm, compared to the 85 cm of the traditional ones.

Among the dredge's strengths are the following: (1) because of the rotation capability of the bucket, it is a very flexible dredger; (2) it is possible to dredge contaminated sludge with a high degree of accuracy due to the horizontal closing of the grab.

This dredge has been used successfully in the Netherlands in projects where no turbidity could be measured and the accuracy was determined to be less than 10 cm.

Limitations:

Type of Power:

Government Funding:

Environmental Concerns:

Health & Safety Plan Available:

Regulatory Approvals

Setup/Feed: Mobilization (days):

Demobilization (days):

Removal Rate Average (m³/hr):

Cost: Capital Cost (US\$):

Unit Cost (US\$/m³):

-

Average Cost (US\$/m³):

Developers:

Baggermaatschappij Boskalis B.V.

Rosmolenweg 20, Postbus 43

3350 AA Papendrecht,

The Netherlands

Notes

Contact:

Phone: (317) 811-1911

Ext:

Fax: (317) 811-1555

Email:

Vendors:

Baggermaatschappij Boskalis B.V.

Rosmolenweg 20, Postbus 43

3350 AA Papendrecht,

The Netherlands

Notes

Contact:

Phone: (317) 811-1911

Ext:

Fax: (317) 811-1555

Email:

Literature References:

Baggermaatschappij Boskalis B.V., Horizontal Closing Environmental Grab

19-Dec-97

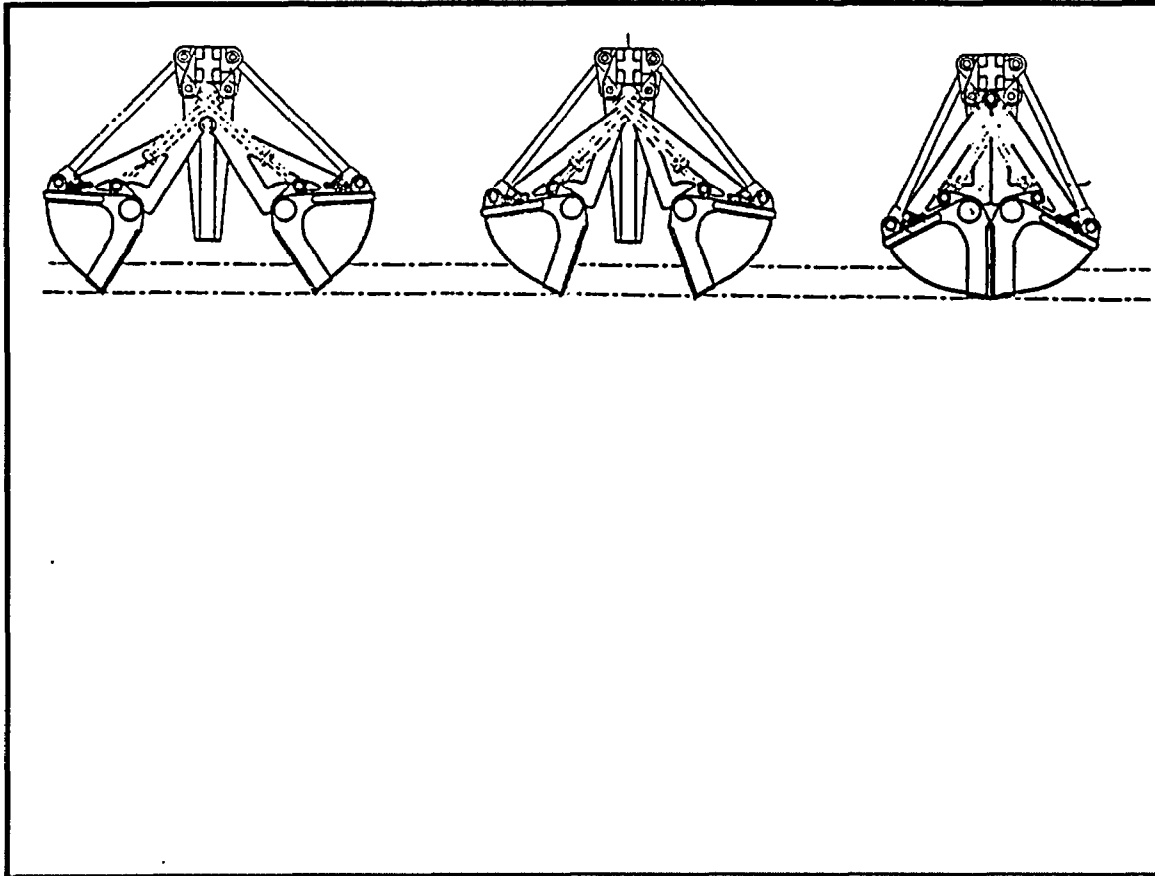

Bean Technical Excavation Corp., BONACAVOR w/ Slurry Processing Unit

19-Dec-97

TechID: 333

Technology Type: Hydraulic, Mechanical

Hydraulic backhoe excavator mounted on jack-up barge.

System Works With: Debris, Strong Currents, Water Depth 2-10m

Can be modified to work in areas with limited accessibility.

Development Stage: Commercial

Country Of Origin: USA

Description:

The BONACAVOR was constructed in 1993 by Bean Technical Excavation Corporation, a subsidiary of the C.F. Bean Corporation. Specifically designed to meet the rigid operating requirements of the U.S. EPA's Superfund project at Bayou Bonfouca, Louisiana, the Bonacavor incorporates the latest technology in dredge positioning, excavation, and contaminated sediment transportation.

Due to the high cost of treating contaminated dredge material, environmental dredging requires the removal of material with as little overdredge as possible within the prescribed excavation template. To facilitate centimeter level vertical and horizontal accuracy for precise sediment removal, the Bonacavor is equipped with state-of-the-art positioning systems. The system uses software, developed by Bean, and high speed computers to indicate the position of the dredge and the bucket location in relation to the excavation template. To control excavator position, position sensors are installed at every joint in the excavator and backhoe arm. Using these sensors, the excavator operator can monitor track turret rotation, arm angle, bucket angle and bucket depth, real-time on a heads up monitor, relative to the vessel and to the 3-D model of the project bottom profile. Also, through a data link, Bean can monitor and manage the operations, real-time, from their main office in Belle Chasse, Louisiana. The positioning system aboard the Bonacavor proved to be extremely accurate on the Bayou Bonfouca project, achieving an overall +/- 7.5 cm excavation tolerance.

Marine environmental remediation projects are also typically constrained by the need to remove contaminated material in as close to an in situ state as possible. To remove the contaminated sediment precisely, and as close to in situ as possible, Bean incorporated a Liebherr P984 backhoe excavator into the design of the Bonacavor. In situ removal of the material also meant less cost, due to the minimizing of any water into the slurry that would have to be treated. The excavator is mounted on top of a turret, on a spud supported jack-up barge, providing a stable platform from which to operate.

Of primary concern on environmental clean-up projects is the risk of exposure of the work crew, the surrounding areas, and the environment to the contaminant. Coupled with the need to minimize and regulate the water content of the slurry mixture being delivered to the treatment facility, Bean invented the Slurry Processing Unit (SPU) as the transportation solution for the Bonacavor. The SPU, U.S. Patent No. 5269635, combines a processing hopper, four pumps, sensors, and injection points controlled by on-board, high speed computers. Sediments brought to the surface are placed on a screen, or grizzly over the SPU hopper bin. Large items are separated out and transported via containment barge to the treatment site. The remaining contaminated material enters the pumping system to be pumped to the treatment site. The desired slurry density and/or velocity of the slurry is controlled by the Slurry Processing Unit. Using measurements from pressure sensors, it automatically injects only the amount of water necessary to maintain the pre-defined slurry density and velocity, eliminating as much as 60% - 80% of the water that would normally be introduced by conventional pumping methods. This greatly reduces water contamination and the subsequent need for treatment allowing the filter presses at the treatment cycle to operate at peak efficiency. A double walled pipeline is used for transport of the material to the treatment facility. There are fewer barge trips to shore since only larger items need to be transported by barge. Fewer barge trips mean less exposure to humans, less risk of accidents and spills, and less project-related traffic on the waterway.

Limitations: Bucket Capacity : 4 m³ (headed)
Reach Limitation: 23 m vertical; 15 m horizontal

Type of Power: Cummins Diesel Engine : KTA 19-C525

Government Funding: Superfund

Environmental Concerns: Minimal dispersion. Silt curtains may be required on certain sites.

Health & Safety Plan Available:

Regulatory Approvals

Setup/Feed: Mobilization (days): _____ Demobilization (days): _____
Removal Rate Average (m³/hr): 75

Cost: Capital Cost (US\$): _____
Unit Cost (US\$/m³): **\$2.60 - \$39.00** Average Cost (US\$/m³): **\$21.00**

Cost calculations are site specific and may range but not be limited to 2.60 - 39.00 US\$/m³.

Developers:

Bean Technical Excavation Corp., BONACAVOR w/ Slurry Processing Unit

19-Dec-97

Bean Technical Excavation Corporation

619 Engineers Rd.
Belle Chase, FL
USA 70037-
Notes

Contact: Taylor Jr., Ancil

Phone: (504) 391-7000 Ext:
Fax: (504) 392-1087
Email:

Vendors:

Bean Technical Excavation Corporation

619 Engineers Rd.
Belle Chase, FL
USA 70037-
Notes

Contact: Taylor Jr., Ancil

Phone: (504) 391-7000 Ext:
Fax: (504) 392-1087
Email:

Literature References:

Author:

Title: Bayou Bonfouca Superfund Cleanup Project

Journal: World Dredging and Mining Construction

Date: Aug 1994

Author:

Title: Bayou Bonfouca Superfund Project : Mission Accomplished

Journal: World Dredging and Mining Construction

Date: Aug 1995

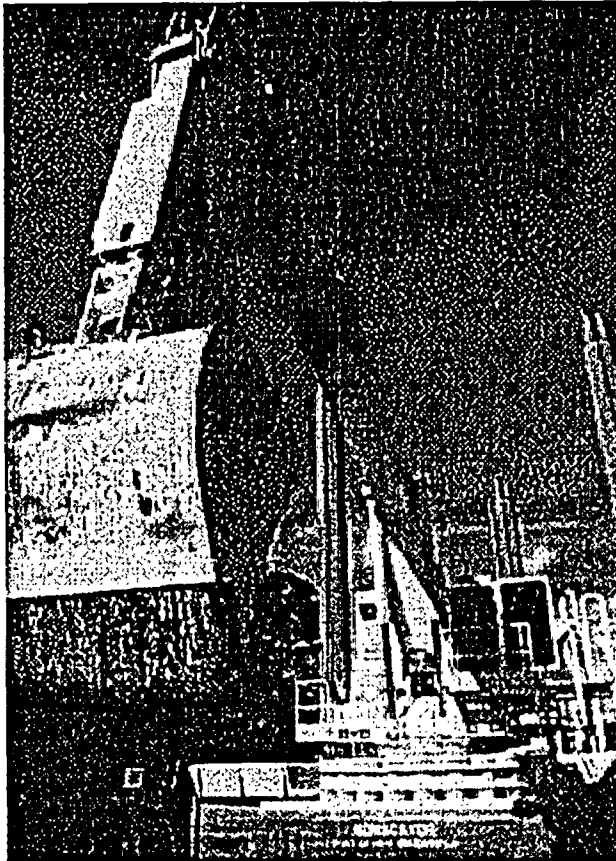

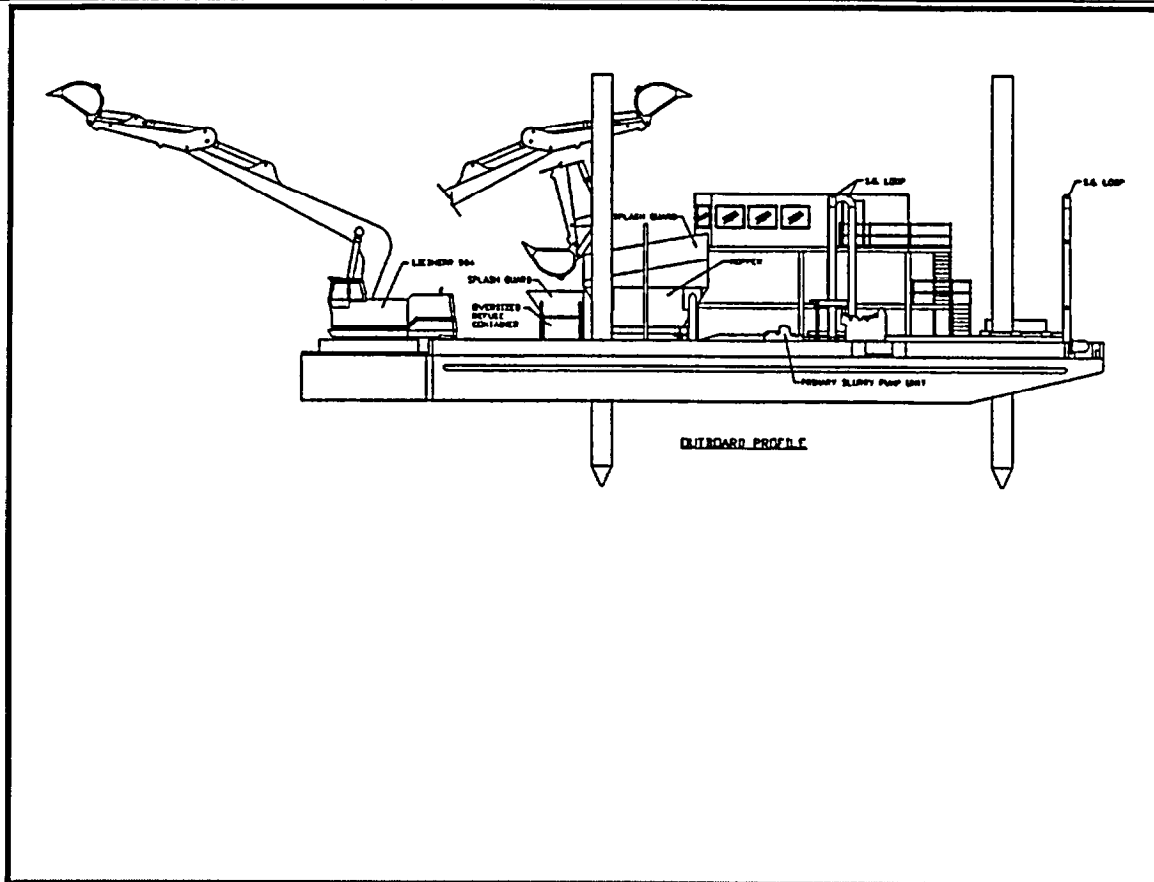

Project: Bayou Bonfouca Superfund Remediation Project

Location: Slidell, Louisiana, USA

Year 94

Full Scale Demo

Client/Funding Agency	Contact	Phone
US EPA Louisiana Dept of Environmental Quality	Paul Sieminski Duane Wilson	(214) 655-8502 (504) 765-0487

Not Monitored

Removal Rate(m³/hr): 75 Amount Removed In-Situ (m³): 124045

Removal Cost(US\$): \$19,000,000.0

Mobilization (days): 4 Demobilization (days): 4

Site Conditions:

Contaminants Present: Creosote (Polyaromatic Hydrocarbon)

Water Quality:

Turbidity:

Total Suspended Solids:

Percent Solids: 16-20%

Site Containment Used? No Yes

Sheetpile & Silt Curtain

Exceed Set Standards? Met or exceeded +/- 7.5 cm excavation tolerance.

Description: The Bayou Bonfouca project was the first test for the dredge Bonacavor and its accompanying technology. The final quantity of material removed from the Bayou was 124,045 m³. The Bonacavor met or exceeded the +/- cm excavation throughout the project with an average overdredging of only 0.17% or 210 m³ over the entire job. The average production for the job was roughly 75 m³/hour, based on a six hour day, and exceeded 400 m³/hour on some days.

Bedrock Resources Inc., REACT Dredging System

19-Dec-97

TechID: 357

Technology Type: Hydraulic, Fluidization

Hopper overflow (effluent) is injected into draghead to fluidize sediment, which is pumped hydraulically.

System Works With: Strong Currents, Water Depth 2-10m, Limited Shore Access

Development Stage: Bench Scale

Country Of Origin: Canada

Description:

"REACT" Dredging System (Recirculate Effluent and Contain Turbidity)

Basic Application:

The basic process was created from the need to reduce the turbidity associated with trailing hopper type dredging technology, for a marine aggregate mining application in close proximity to a major municipal water intake. The conventional hopper dredge is modified primarily by collecting the overflow water with a system of underflow drains and overflow collection, and then pumping this low solids content mixture to a specially designed draghead to be used as "jetting" water to fluidize the bottom sediment. A dredge pump mounted on the draghead is used to provide maximum solids concentration in the dredged slurry. At the end of the dredging cycle the excess water remaining in the hopper on top of the cargo is drained through the underflow drains prior to discharge (i.e. filtered through a sand bed), or if heavily contaminated sediments are being dredged, the excess water will be brought to shore for appropriate treatment.

High Silt Concentration Application:

When required to dredge sediments with increased silt concentrations, the process is modified by installing a screen to remove the coarse sand/gravel fraction from the flow of slurry (and possible return to watercourse via a separate barge or flow arrangement), with the remaining slurry of water and fine contaminated sediments pumped through a cluster of small cyclones for densification of the fine particles, which are discharged into the hopper for transport to port. Only the cyclone overflow is pumped to the draghead for use as "jetting" water.

Harbour/Shore Area Dredging:

The process is adapted for use near shore or in harbours by using a land based containment system and replacing the hopper barge with a hydraulic excavator mounted on a spud barge. The recirculation draghead and submerged pump are positioned on the end of the excavator dipper stick, and moved about the area immediately in front of the barge which is held stationary by the spuds. Barge movement is by means of tugs and/or cables attached to suitable anchors. The slurry is pumped to either (1) standard size highway dump trailers modified with sealed tailgates, with a floating suction arrangement to collect turbid water from the surface of the slurry contained in the trailer, or (2) a shore side concentration and treatment facility. In either case, the effluent from the slurry is pumped back to the draghead via a line parallel to the dredge line for injection into the draghead. In the case of using dump trailers for transport, the floating suction to remove excess effluent is positioned above the trailer by either a crane or scaffold-like structure that the trucks drive under. By using standard highway trailers the cost of transporting to landfill (or other treatment facilities) is minimized.

Projects:

Currently a table top model of the system has been constructed and successfully operated, and further testing is being done at the University of Windsor in preparation for construction of a Pilot Size trial later this year.

Limitations: Normal limitations of hydraulic dredging.

Type of Power: Diesel-electric

Government Funding:

Environmental Concerns: Turbidity monitoring required to confirm proper re-circulation rates.

Health & Safety Plan Available:

Regulatory Approvals

Setup/Feed: Mobilization (days):

Demobilization (days):

Removal Rate Average (m³/hr):

Cost: Capital Cost (US\$): \$1,354,000.

Unit Cost (US\$/m³): \$10.00 – \$20.00

Average Cost (US\$/m³): \$15.00

Depends greatly on grain size of material being dredged. Capital cost does not include tug, support equipment, etc.

Developers:

Bedrock Resources Inc., REACT Dredging System

19-Dec-97

Bedrock Resources Inc.

1034 Lilydale Ave., RR #1
Belle River, Ontario
Canada NOR1A0
Notes

Contact: Kennette, Francis

Phone: (519) 727-6257 Ext:
Fax: (519) 727-5569
Email: bedrock@MNSi.net

Vendors:

Bedrock Resources Inc.

1034 Lilydale Ave., RR #1
Belle River, Ontario
Canada NOR1A0
Notes

Contact: Kennette, Francis

Phone: (519) 727-6257 Ext:
Fax: (519) 727-5569
Email: bedrock@MNSi.net

Literature References:

Cable Arm (Canada) Inc., Cable Arm Clamshell Bucket

22-Dec-97

TechID: 235

Technology Type: Mechanical

System Works With: Debris, Water Depth 2-10m, Limited Shore Access

Excellent in soft mud and contaminated sediments.

Development Stage: Commercial

Country Of Origin: USA

Description:

- Clamshell bucket design: produces a level cut profile
- Large footprint - 2/3 larger than conventional bucket with same capacity
- Sealed system - for contaminated sediments
- High solids production - water venting system
- 40% less weight (more payload)
- Ease of placement
- Adaptable to instrumentation
- Produces low turbidity/suspended solids

Limitations: Light/fluffy sediment < 30% solids.
Not a digging clam - soft sediment only.

Type of Power: Crane (Diesel/Electric - 2 Cable System).

Government Funding: Great Lakes Cleanup Fund, DESRT

Environmental Concerns:

Health & Safety Plan Available:

Regulatory Approvals Ontario Hydro Pickering Nuclear Cooling Water Intake Channel Dredging Specification "Cable Arm Clamshell or Comparable". Approval under Section 33 of the Fisheries Act.

Setup/Feed: Mobilization (days):

Demobilization (days):

Removal Rate Average (m³/hr): 300

Cost:

Capital Cost (US\$): \$75,000,000

Unit Cost (US\$/m³): \$2.00 - \$12.00

Average Cost (US\$/m³): \$7.00

Cable Arm (Canada) Inc.: 15 m³ bucket size; (for environmental dredging add 15.00 US\$/m³ to minimum).

	Min.	Max.	Avg.
Cable Arm (Canada) Inc.:	2.00	3.75	2.87
Verrault Navigation Inc.	7.00	12.00	8.00

Note: For Environmental Dredging removal rate is increased by a factor of 3. Thus regular removal rate average would be 100 m³/hr.

Developers:

Cable Arm Inc.

3452 W. Jefferson Avenue
Trenton, MI

USA 48183-2939

Notes

Contact: Bergeron, Ray

Phone: (313) 676-6108

Ext:

Fax: (313) 676-1345

Email:

Vendors:

Harbour Development

P.O.B. 497

Dartmouth, NS

Canada B2Y3Y8

Notes

Contact: DeWolfe, W.L.

Phone: (902) 494-5767

Ext:

Fax: (902) 466-2483

Email:

Cable Arm (Canada) Inc., Cable Arm Clamshell Bucket

22-Dec-97

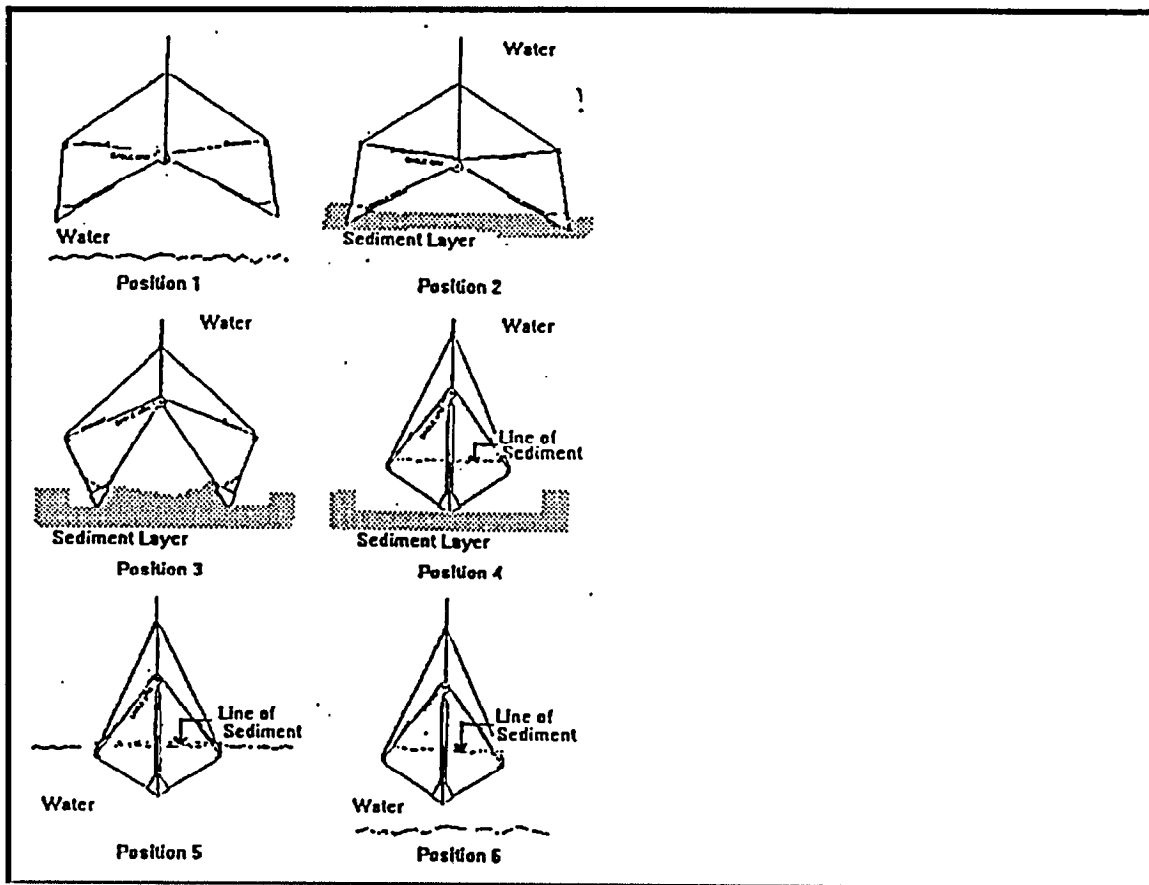

Project: Pickering NGS Funnel Dredging

Year 93

Location: Pickering Nuclear Generating Station, Pickering, Ontario, Canada

Commercial

Client/Funding Agency	Contact	Phone
Ontario Hydro Remediation Technologies Program/Great Lakes Cleanup Fund	Ian Orchard	(416) 739-5874

* Monitored * Auditor: Ian Orchard (Environment Canada) Phone: (416) 739-5874

Removal Rate(m³/hr): 23 Amount Removed In-Situ (m³): 160

Removal Cost(US\$): \$92,880.00

Mobilization (days): 2 Demobilization (days): 1

Site Conditions: Since commissioning, Pickering B Nuclear Generating Station (NGS) has experienced sediment entrainment problems within the cooling water intake channel resulting in frequent filtering problems. A comprehensive one year study was undertaken to evaluate sediment transport in the vicinity of Pickering NGS. The results of this study concluded that the lake environment offshore from Pickering NGS is a complex interactive system of dynamic environments. Given the complexity of the sediment transport process, it was difficult to accurately determine and quantify the sediment transport load. The sediment transport varies significantly throughout the year. The estimated sediment load in Pickering reaches approximately 11,300 tonnes per year, of which approximately 380 tonnes enter the station's intake channel.

A solution to the station's sedimentation problem was to install a sediment by-pass system in 1990. The system is comprised of precast concrete slabs creating a funnel shape approximately 60 feet in diameter. The sediment will be pumped through a seven foot diameter fibreglass pipe to the tempering screenhouse and then into the discharge channel.

Low re-suspension of bottom material was a prerequisite since most of the water intake would still be in operation during dredging. It was therefore crucial that turbidity and total suspended solids levels be kept to a minimum throughout the dredging operations. In the work specifications, Ontario Hydro requested that the TSS level be not increased by more than 10 mg/L at 25 m from the dredge, (the closest water intake was located between 15 and 25 m from the dredge [depending on the position of the dredge]).

The water depth in the dredging area averaged 7 m, while the intake velocity was 1.5 m/s.

Contaminants Present:	Contaminants	Concentration (ug/g, dry)	LEL (ug/g)	SEL (ug/g)
	Total Organic Carbon	16,100	10,000	100,000
	Chromium	58.0	26	110
	Copper	48.5	16	110
	Iron	25,200	20,000	40,000
	Nickel	16.3	16	75

Those numbers are the results from a sediment sampling survey performed during the month February 1993.

The LEL and the SEL are both guidelines established by the Ontario Ministry of the Environment & Energy for the protection and management of aquatic sediment quality in Ontario. The LEL represents the lowest concentration where a contaminant will have an effect on benthic organisms, while the SEL is the concentration where contaminants will have a detrimental effect to the majority of benthic organisms.

Water Quality: The intake channel at Pickering NGS receives water directly from Lake Ontario. The water quality is therefore dependent on the Lake's conditions. The sediment transport varies significantly throughout the year. The estimated sediment load in Pickering reaches approximately 11,300 tonnes per year, of which approximately 380 tonnes enter the station's intake channel.

At the beginning of the project, background Total Suspended Solids concentration was at 12 mg/L, while the turbidity was at 3 NTU.

Turbidity: A Monitek nephelometer was used on May 18, 20, and 21, 1993. In order to use this monitor, a 6.2 L Kemmerer sampler was used to collect samples. A small amount of the 6.2 L was transferred in a bottle to be placed in the nephelometer.

On May 25, 1993, a multi-parameter monitor was used to measure turbidity, dissolved oxygen, conductivity, pH, temperature and salinity. The Horiba U-10 water Quality Checker was pre-calibrated using an auto-calibration solution prior to its use in Pickering. The turbidity was always measured at 15 m from the dredge (at the intake).

Results for turbidity have indicated that, even during the time when material was being spilled from the bucket, the turbidity never exceeded 7 NTU.

These odd turbidity levels are most likely due to two factors: 1) since a current was present, the passage of the dredging plume could have been missed, therefore showing low turbidity caused by the dredge, 2) the presence of all-size debris could not be measured by the nephelometer. Since a great percentage of the surficial material on top of the funnel was composed of algae, leaves, fish and branches, it is realistic to

Cable Arm (Canada) Inc., Cable Arm Clamshell Bucket

22-Dec-97

believe that the nephelometer could not measure the decrease in clarity of the water caused by these debris since the sampler would not capture them.

Total Suspended Solids: Monitoring for TSS concentration in the water column is usually performed by taking samples, and by sending them to a laboratory. A two-three weeks turn-around period is then expected before results are received.

An OBS-3 monitor (SN63901) was hooked up to a data logger (Campbell Scientific CR21X, SN9609) that allowed readings to be logged every 10 seconds. A memory module (SM716, SN3793) was also used in order to allow easier retrieval of data in the field. A Compaq 386 LTE Lite/25 notebook was used for retrieval and interpretation of data.

Calibration of the monitor for TSS was performed using sediment sampled from the mid-funnel area in February of 1993. Standard calibration was performed the week prior to the dredging project. It consisted of the addition of a defined amount of sediment in a large dark pail (40 L) filled with water, followed by sampling for TSS and reading of output from the OBS-3 monitor (millivolts). The solution was constantly stirred. This path was repeated 3 times. The samples were filtered, dried in oven for 24 hours and weighted to get the corresponding TSS concentration of each sample.

A graph showing the TSS levels corresponding to the readings from the OBS-3 monitor was then produced. The best curve was then found with its corresponding equation, and a calibration curve was put together. Since a reading was taken every 10 sec, an average of all the readings taken during the time the solution was at a certain TSS concentration was performed (approximately 80-100 readings). This allowed an appropriate variance to be maintained throughout the calibration.

During the project (on May 18), the OBS-3 monitor was placed adjacent to the screenhouse wall, immediately beside intake #5 (Station 1) at a water depth of approximately 7 m, and approximately 13 m away from the mid-funnel area. On May 20 and 21, the monitor was put at approximately 5-10 m upstream from the bucket and 7 m deep (Station 2) in order to monitor the potential effects of a secondary current on the concentration of suspended solids released in the environment by the dredging operation.

Total suspended solids concentrations have shown a relationship with the operator's lack/increase of knowledge of the specific operating procedures related to the Cable Arm Environmental Clamshell Bucket. During the first day, several bucket loads were overfilled resulting in important increase of total suspended solids concentrations. During the 158 minutes of dredging, the total suspended solids concentrations were increased to levels as high as 110 mg/L at approximately five occasions, but the average total suspended solids concentration was slightly below or above the pre-set limit of 22 mg/L. In fact, all five occasions when the concentration of TSS reached levels as high as 110 mg/L were all related to overfilling events. As dredging continued, the operator became more familiar with the operating procedures related to this environmental bucket, and TSS concentrations recorded decreased significantly to levels at the pre-set limit, and most of the time below the 22 mg/L limit.

Percent Solids: Sample analyses showed that the percentage of solids in the sludge was approximately 60% (dry basis).

Site Containment Used? No Yes

Exceed Set Standards? Low re-suspension of bottom material was a prerequisite since most of the water intake would still be in operation during dredging. It was therefore crucial that turbidity and total suspended solids levels be kept to a minimum throughout the dredging operations. In the work specifications, Ontario Hydro requested that the TSS level be not increased by more than 10 mg/L at 25 m from the dredge, (the closest water intake was located between 15 and 25 m from the dredge [depending on the position of the dredge]).

At the beginning of the removal operations, overfilling of the bucket occurred due to the operator's lack of training with the Cable Arm bucket and the depth transducer. During that operator's on-site training process, the concentration of re-suspended material did exceed the limits pre-set by Ontario Hydro, but at no time required shut down of the nuclear plant operations. As the operator was gaining confidence, overfilling events became more sparse thus decreasing the re-suspension of material. From that time, the pre-set limit of 22 mg/L was rarely exceeded.

The most important objective of this project was successfully met when no effect on station operation and reactor safety was noticed by Ontario Hydro personnel. It is believed that a cost saving was realized by using the Cable Arm Environmental bucket since no shut down of operation was necessary.

Description: The Cable Arm bucket used for this first commercial application had a maximum capacity of 3.2 m³ and was equipped with an underwater camera, a closure confirmation system, an air-operated vents dewatering system and a depth transducer.

A demonstration of a 2-dimensional scanning sonar system was performed for the Remediation Technologies Program of Environment Canada. The scanner was an Imaginex colour system used to provide horizontal positioning information.

Removal Rate :

Conventional dredging methodologies, mechanic and hydraulic were investigated to remove lake sediment from the

Cable Arm (Canada) Inc., Cable Arm Clamshell Bucket

22-Dec-97

funnel area. Due to the amount of sediment re-suspension created by conventional technologies including problems with the containment and treatment of discharge water, conventional dredging operations were not chosen. The Cable Arm 100E bucket was selected in order to meet both Environmental Regulatory standards and Ontario Hydro's operational requirements. This innovative mechanical dredge was demonstrated in 1992 by the Remediation Technologies Program of Environment Canada and proved to be very effective at maintaining the re-suspension of sediment at very low levels, while increasing the solids/liquid ratio. These two qualities made to the Cable Arm 100E bucket the best choice for this dredging work.

After a public tenders process, Ontario Hydro awarded Canadian Dredge and Dock (CDD) of Toronto, Ontario, in April of 1993, with the contract to dredge approximately 160 m³ of material that had accumulated on top of the funnel. As part of the work specifications, a Cable Arm 100E bucket was to be used to remove the material.

The total time required to remove the requested volume of bottom material was approximately 7 hours. The average production rate was therefore approximately 23 m³/hr, with an average cycle time of 8 minutes. At the beginning of the project, Pickering NGS requested a cycle time of 10 minutes to ensure that the amount of re-suspended material between dredging cycles be minimized.

Amount Removed in-situ (m³) :

In total, two 58.3 m³ containers were filled to capacity twice, leading to a volume of sludge of approximately 160 m³ of bottom material consisting mainly of organic debris (leaves, branches, dead fish, etc.). Sample analyses showed that the percentage of solids in the sludge was approximately 60% (dry basis), therefore leading to a volume of dry bottom material removed of approximately 96 m³.

Removal Cost :

The total cost of this project was 92,880 \$(US) (unit cost of 580.50 \$(US)/m³). This high cost is mostly due to Ontario Hydro strict health and safety requirements related to dredging at a nuclear station and restrictions on production rate.

Mobilization Time (days) : 1.5

Mobilization in Pickering NGS intake channel started on 17 May 1993 and ended on 18 May 1993 at noon. The equipment brought on site consisted of a 3900 Manitowoc 80-ton crawler crane equipped with 2.5 m³ Cable Arm clamshell bucket mounted on a barge measuring 12 m x 36 m x 2.7 m equipped with two steel spuds. Two 58.3 m³ steel containment bins to receive and transport the dredged material were positioned on a flat deck barge measuring 9.1 m x 27 m x 2.4 m. Figure 1 shows the location of the barge related to the nuclear station and the funnel.

A 650 HP tug was used to tow the dredge unit and flat deck barge from the dredge site to the shore containment site. The tug also provided transportation from shore to the dredging unit for personnel and equipment.

Demobilization Time (days) : 1

All the equipment was demobilized from the Nuclear Station's intake channel on 26 May 1993.

Bibliography:

C.B. Faim & Associates Ltd. 1993. Report on Funnel Dredging of Sediments, Ontario Hydro Pickering NGS B, Cooling Water Intake Channel. Report for the Contaminated Sediment Removal Program of Environment Canada. June.

Cable Arm Inc., L.B. Tanker Inc. 1993. Ontario Hydro - Nuclear Plant Cooling Water Intake Channel Dredging.

McQuest Marine Research and Development Company Ltd. 1993. Evaluation of an Acoustic Scanner for Bucket Positioning During Dredging Operations, Pickering Nuclear Station.

Pelletier, J-P., R. Santiago & J. Lajeunesse. 1994. Evolution of Cable Arm Clamshell Bucket. Proceedings of the Second International Conference on Dredging and Dredged Material Placement. Dredging '94. Volume 2. p.1050-1060.

Persaud, D., R. Jaagumagi and A. Hayton. 1992. Guidelines for the Protection and Management of Aquatic Sediment Quality in Ontario. Water Resources Branch, Ontario Ministry of the Environment and Energy. June.

Regulatory Approvals :

As part of the project, several approvals and permits are required from various departments of the federal & provincial governments.

Federal Government

- Canadian Coast Guard, Department of Transport

a) Approval to "Dredge in a Navigable Waterway under Section 5(2) of the Navigable Waters Protection Act (NWP), RSC 1985, Chapter N-22".

Provincial Approval

-Ministry of Natural Resources (MNR)

Lakes & River improvements Act

Fisheries Act

-Ministry of the Environment and Energy

-Environmental Protection Act

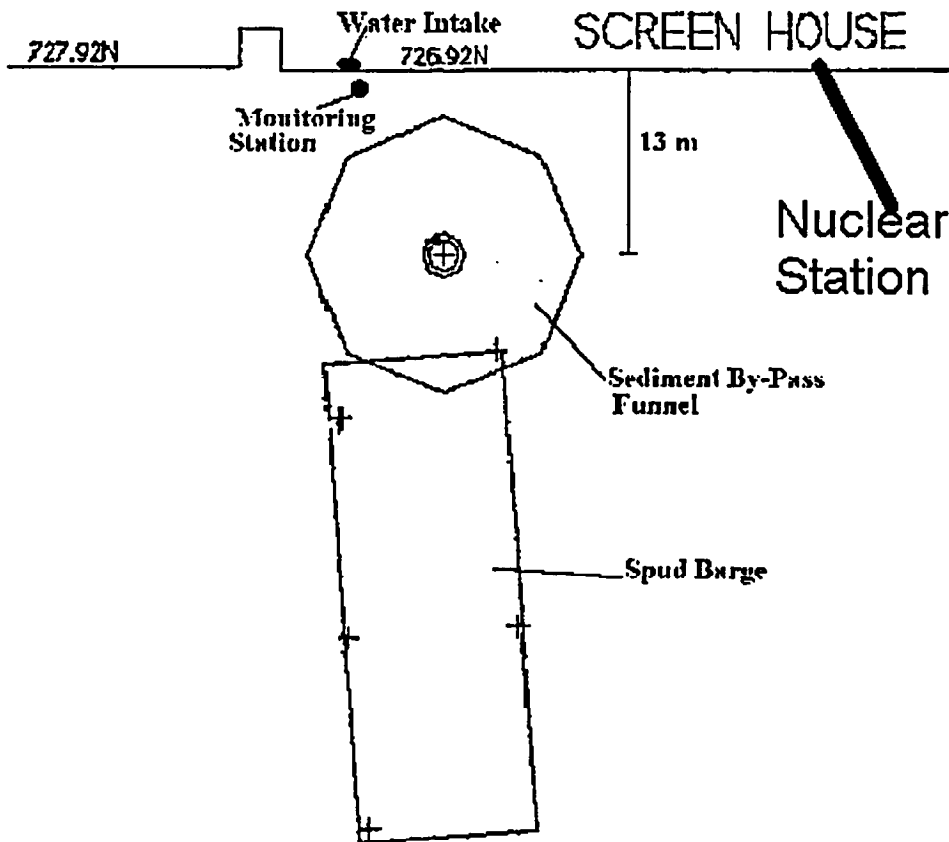

Project: Hamilton Harbour Sediment Removal Demonstration

Location: Hamilton Harbour (Pier 15-16)

Year 92
Pilot Scale

Client/Funding Agency	Contact	Phone
Remediation Technologies Program/Great Lake Cleanup Fund	Ian Orchard	(416) 739-5874
Stelco Inc.	-	-
Dofasco Inc.	-	-
The Regional Municipality of Hamilton-Wentworth	-	-
The City of Hamilton	-	-
The Ontario Ministry of the Environment & Energy	-	-

* Monitored * Auditor: Ian Orchard (Environment Canada)

Phone: (416) 739-5874

Removal Rate(m³/hr): Amount Removed In-Situ (m³): 150

Removal Cost(US\$): \$144,000.00

Mobilization (days): 2 Demobilization (days): 6

Site Conditions: In the summer of 1992, a sediment sampling survey was undertaken by the Wastewater Technology Centre (WTC) in the study area. During the survey, the sampling crew noticed an odour from the sediment collected, and an oily sheen on the water surface, indicating that oil is being released from the sediment. They have also noticed that black tar like material was present in visible amounts as a separate phase. Past studies have shown that, in this area, the tarry/oily sediment can go as deep as 30-40 cm as per 1990.

Particle size analyses performed on those samples have shown that approximately 65% of the material was of very fine particle size (sub-75 microns). Chromium, iron and zinc were the only metals with concentrations above the Ontario MOEE's severe effects level guideline. Total Polyaromatic Hydrocarbons concentration were approximately 1,000 ppm. The high molecular weight PAHs (4 to 6 ring compounds) made up over half of the total PAHs.

Whole sediments from near Pier 16, 18/20 greatly depressed the oxygen consumption of the bacteria Photobacterium, whereas other sediments were much less toxic. Sediment near Pier 16 in the removal area are anoxic and contain an extremely high concentration of hydrogen sulphide (100 mg/l). Hydrogen sulphide is believed to be the cause of the high toxicity of the sediment located in the area (Murphy, 1990). Coal tar cannot be biodegraded in anoxic sediments (Heikamp and Cerniglia 1987, Mihelcic and Luthy 1988).

In the beginning of the summer of 1992, Dr. Tom Murphy of the National Water Research Institute started

Cable Arm (Canada) Inc., Cable Arm Clamshell Bucket

22-Dec-97

bench and pilot scale treatments of the sediments located in the study area (between Randle Reef and Pier 16), in the deep basin of Hamilton Harbour and in Dofasco's boat slip. Calcium nitrate was injected in the sediment to a depth of 20 cm. It was believed that, by injecting calcium nitrate in the top 20 cm, the production of hydrogen sulphide would be decreased, and that the sediment would have an increased and more stable oxygen level. This would allow the natural organisms, present in the sediment, to biodegrade the PAH molecules contaminating the bottom material.

The Remediation Technologies Program managed to coordinate removal of this top 20 cm of pre-treated sediment during a demonstration of the Cable Arm Environmental Clamshell bucket.

Unfortunately, a sounding survey was not performed prior to the demonstration. Depth readings were made using a "Low Range C" fish finder prior during and after the demonstration. It was found that the water depth prior to the removal operation varied between approximately 8.8 to 9.2 m. Post-demonstration readings in the dredge areas indicated that water depth ranged from approximately 9.6 to 9.7 m in the unpre-treated zone, while it ranged from 9.2 to 9.3 m in the pre-treated zone.

Contaminants Present:	Contaminants	Max. Concentration (ug/g, dry)	LEL (ug/g)	SEL (ug/g)
	1) PAHs	>1200	4	1,000
	2) Chromium	>110	26	110
	3) Iron	>40,000	20,000	40,000
	4) Zinc	>820	120	820

The LEL represents the lowest concentration where a contaminant will have an effect on benthic organisms, while the SEL is the concentration where contaminants will have a detrimental effect to the majority of benthic organisms. The SEL for PAHs is also dependent on the concentration of total organic carbon.

Water Quality: Three of the most important water quality problems present in Hamilton are related to oxygen depletion and water clarity. These are excessive ammonia loading from primarily sewage treatment plants, phosphorus loadings from several sources, and high levels of suspended solids from industries, streams, STPs, and sewage overflows.

Ammonia concentrations are a function of loadings versus biological processes and flushing losses to Lake Ontario. The most important biological processes are bacterial nitrification and algal uptake which are processes controlled by temperature. Therefore, ammonia accumulates during the winter. The nitrification starts in the spring when the water temperature rises. In so doing, the oxygen level in the harbour water is reduced.

Although a decrease in phosphorus levels within the harbour has occurred since nutrient controls were introduced in the early 1970's, A definite decrease in phosphorus loading was noticed since 1974. Water clarity is another problem in the harbour. Two important factors related to water clarity are the chlorophyll a and the suspended solid concentrations. It was found that the shoreline secchi disk transparencies averaged 0.95 m but only the first 100 meters from the shore had these reduced transparencies. Any location with water depths greater than 2 m had a water clarity similar to offshore water clarity.

Other contaminants such as metals and organics plays also an important role in the water quality of the harbour. The major sources of metals to the harbour are the steel industries. Since the implementation of loading reductions from the iron and steel industries in 1983/84, the average concentrations of metals meet the PWQO. The industries are also the largest dischargers of organic contaminants. The average contaminants of organic compounds meet the PWQO (when there is one).

Turbidity: This water quality monitoring program included sampling runs performed prior to, during and after the demonstration. The pre-demonstration sampling runs were performed on September 30, October 1 and 6, 1992. All days were sunny, with low winds. The demonstration (October 9) runs was performed during sunny days with strong wind in the afternoon, preceded by the same weather. The post-demonstration sampling runs (October 13 and 14) were performed on sunny days, with medium wind.

A 6.2 litre Kemmerer sampler composed of transparent polyvinyl chloride and acrylic plastic with silicone rubber seals was used for collection of water samples. The samples were collected one meter below the water surface (1A, 2A and 3A) and one meter above the sediment surface (1B, 2B and 3B). All bottles used for the samples were filled with one sampler load.

Three official sampling stations were chosen. Station 1 was located 25 m outside the dredge cell. Station 2 was located 10 meters from the work area, while station 3 was in the work area. Turbidity readings were performed in field at each station using a Monitek nephelometer.

Figure 2 shows the variation of turbidity in the demonstration area throughout the entire water quality monitoring program. It can be seen that the pre-demonstration levels for all stations were very low, between 1 & 3 NTU. The operational standards call for an increase in turbidity not to be higher than 30% of the background level at 25m from the dredge (Station 1). Therefore, an increase in turbidity of a maximum of 0.9 NTU was to be the set limit. From Figure 2, it can be seen that the level of turbidity never went over the 3.9 NTU limit at Station 1.

Figure 2 shows the expected pattern for the level of turbidity in the dredge cell: a background level comparable to the other station, an increase in turbidity in the dredge cell and a level of turbidity that stays higher than outside the dredge cell throughout the entire demonstration, and a decrease to background level after the demonstration. Figure 3 shows that the highest level of turbidity created by the Cable Arm 100E bucket was only 4.5 NTU, which is negligible. In order to notice a dredging plume, levels of turbidity of approximately 15 NTU are required. Therefore, at 4.5 NTU, it can be assumed that no dredging plume was produced in the dredge cell when samples were taken.

Total Suspended Solids: Figure 3 shows the same type of results for TSS compared to turbidity: a low background concentration, an important increase in the dredge cell during the demonstration, and a decrease to background level in the dredge cell after the demonstration. The importance of this figure is the fact that it shows clearly that the level of suspended material was mostly higher outside than inside the dredge cell. These results could be due to: a) the tug boat going to and coming from McKeil Marine's property re-suspending material, or b) sand from the top of the Erie West barge being introduced in the samples by the wind. The tug boat was resuspending a great amount of material.

The operational standards call for an increase in the concentration of total suspended solids of 25 mg/l or less at 25m from the dredge. Figure 4 shows that the TSS level at Station 1 did increase by more than 25 mg/l. The increase is believed to have no relationship to the dredging activity, but it is related to the tug boat re-suspended material, or sand introduced in the samples by the wind. The removal activities ended within the hour following these measurements. Also as shown on Figure 3, the level of TSS went back to background level after dredging.

Percent Solids: The results of sludge samples indicated percentages of solids between 44% and 48%.

Site Containment Used? No Yes

Due to the success of the working cell used in the Toronto Harbour demonstration, the same system set-up was put in place for this demonstration. This time, four pieces of 10.9 m x 10.3 m Terrafix 400 were sewn together making up the working cell and hung from 1 m above the water surface and down to 1.5 m above the harbour bottom. A floating oil boom was secured inside the working cell in order to prevent gross contamination of the curtain.

Exceed Set Standards? The Remediation Technologies Program of Environment Canada has developed a set of standards in order to audit demonstrated innovative sediment removal technologies. The following are those standards :

Sediment Removal Phase :

- 1) Turbidity: Turbidity beyond a distance of 25 m of the actual removal location shall not exceed ambient levels by more than 30%.
- 2) Suspended Solids: Beyond a 25 m distance of the actual removal location, suspended solids shall not exceed ambient levels by more than 25 mg/l.
- 3) Total Organic Carbon: Total Organic Carbon (TOC) content should be within the range of 0.4-27 mg/l in surface water beyond 25 m of the removal operation. TOC shall not exceed background levels by more than 30% when background concentrations are greater than 27 mg/l.
- 4) No Overflow or Leaks: A minimum freeboard of 1 m must be maintained in the hopper of holding facility for the excavated sediment. The holding facility must be sealed for transport to the pre-treatment/disposal site.
- 5) Removal Efficiency: The solids to liquids ratio in the excavated material should be at least 30% by volume.
- 6) Effluent Quality: Maximization of solids removal is paramount. Solids suspended in the slurry mixture must be removed by some means, either mechanical or chemical (flocculation). If the extracted material is fine grained, provision should be made to treat the effluent.
- 7) Production Rate: The production rate of the sediment removal equipment should be adjusted to show sufficient settling time for effluent to meet the Provincial Water Quality Objectives (PWQOs). Therefore, the feed rate of the excavated material into the holding facility for transport to the pre-treatment disposal area should be adjusted accordingly.

Transport Phase:

- 1) No Overflow or Leaks: No overflow or leaks of excavated material shall be allowed during transport to the disposal or pre-treatment area. Use of pipelines or other fully closed transport mediums is encouraged.
- 2) Transport Rate: The rate of material being transported must be adjusted to meet the handling capacity of the pre-treatment or disposal facility.
- 3) Contact: No contact is permissible between the contaminated sediment and human, bird and aquatic life.

Pre-treatment Phase :

- 1) Effluent Quality: Effluent quality of the supernatant water and effluent from the pre-treatment process should meet applicable federal and provincial standards and guidelines.
- 2) Waste Handling: All wastes from the pre-treatment process should be handled and disposed of in accordance with appropriate regulatory requirements.

Description: Based on recommendations from the Toronto demonstration and site conditions in Hamilton the following modifications were made to the bucket: neoprene and gasket seals were added to provide a positive seal during closure; inner side plates were used to reduce the lateral movement of sediment; ; a external reeving system was used to eliminate sediment contact; a epoxy coating was used on the bucket surface to reduce coal tar adhesion. Independent seal ports were used to maximize solids content for different sediment cuts. Using the lower vent, the maximum capacity was 3.2 m3 allowing

Cable Arm (Canada) Inc., Cable Arm Clamshell Bucket

22-Dec-97

removal treated sediment to a depth of 20 cm. Using the upper vent, the maximum capacity of the bucket was increased to 4.8 m3 allowing removal of 30 cm of untreated sediment.

Removal Rate :

The cycle time averaged approximately 2 minutes and 30 seconds. The increased length of time related to positioning of the bucket (slower descent and precision placement) and the pause at the surface for decantation purposes added as much as 1 minute. It is again believed that, with proper operator training and use of a positioning system, the cycle time could be reduced to anywhere between 1 minute to 1 minute and 30 seconds (depending on water depth).

The working cell (details in section "confinement") was not large enough, therefore restricting the full use of the crane boom and the clamshell footprint. Excessive time was therefore spent moving the working cell since only six cycles could be performed with the size of the cell used in Hamilton Harbour.

Amount Removed In-Situ (m3) :

The total volume of contaminated sediment planned to be removed during this demonstration was 150 m3: 60 m3 of pre-treated material, and 90 m3 of untreated material in an area adjacent to the pre-treatment area. Once removed, the material was taken to a bio-remediation treatment plant located nearby in Hamilton Harbour. The treatment process required that the removed material be free of debris and have a percent solids of approximately 50% (dry basis).

Removal Cost :

The total of this demonstration was 144,000 \$(US) (unit price of 960 \$(US)/m3). This high cost was related to special demonstration requirements and to health & safety requirements related to dredging in highly contaminated sediment.

Mobilization Time (Days) : 2

Mobilization started on 06 October, and ended on 08 October, 1992. A 82 m x 15 m deck barge was anchored to Pier 15 in order to provide a stable anchoring point to the flat deck barges which would be used to place the crane, the containers and the rest of the required equipment (Figure 1). Due to the success of the working cell used in the Toronto Harbour demonstration, the same apparatus was put in place for this demonstration. In order to ensure that the removed material would meet all the requirements for immediate treatment, a 3 m x 3 m classifying screen with a sieve of approximately 5 cm was placed on top of the containers to remove any debris that would be dredged with the sediment.

The following is a list of equipment used in the demonstration :

- a) Cable 100E Clamshell Bucket
- b) Erie West (82 m x 15 m) deck barge
- c) Flat Deck Barge "Cargo Carrier" (27.4 m x 18.28 m)
 - Crane (Lima 1250)
 - Wash pump truck
 - Container used as video station and safety supply storage
- d) Flat Deck Barge "974" (42.7 m x 12.2 m)
 - 2 (47 m3) storage bins
 - 2 (65 m3) storage bins
 - 12 lugger boxes
- e) Floating platforms
- f) Silt curtain
- g) Transport bins
- h) Classifying screen
- i) Wash tray
- k) positioning equipment

Demobilization Time (Days) : 6

Cleanup and demobilization was mostly completed on 10 October 1992. The Erie West remained tied off to Pier 16 until 15 October 1992.

Regulatory Approvals :

As part of the demonstration project, several approvals and permits are required from various departments of the federal government and from property owners affected by the project.

Federal Government:**Canadian Coast Guard, Department of Transportation:**

Approval to "Dredge in a Navigable Waterway under Section 5(2) of the Navigable Waters Protection Act, RSC 1985, Chapter N 22".

Department of Fisheries and Oceans:

Approval under Section 33 of the Fisheries Act.

Federal Environmental Assessment and Review Office:

Initial Screening of the proposal undertaking in keeping with the requirements of EARP.

- Approval from the Hamilton Harbour Commission to dredge in the harbour and to use the Confined Disposal Facility.

Cable Arm (Canada) Inc., Cable Arm Clamshell Bucket

22-Dec-97

Affected Property Owners:
- Stelco
- McKeil Marine (one of the contractors)

Bibliography:
Cable-Arm Inc., L.B. Tanker. 1991. Proposal for Demonstration of Innovative Technology for Removal of Contaminated Sediment in Great Lakes Areas of Concern. Proposal for the Contaminated Sediment Removal Program of Environment Canada. June.

Hamilton Harbour Remedial Action Plan Team. 1989. Environmental Conditions & Problem Definitions. Environment Canada & Environment Ontario.

Hamilton Harbour Remedial Action Plan Team. 1991. The Remedial Actions for Hamilton Harbour. Draft. Environment Canada & Environment Ontario. December.

Heitkamp, M.A. and C.E. Cerniglia. 1987. Effects of Chemical Structure and Exposure on Microbial Degradation of Polycyclic Aromatic Hydrocarbons in Freshwater and Estuarine Ecosystems. Environ. Toxicol. Chem. 6:535-546.

Mihelcic, J.R. and R.G. Luthy. 1988. Microbial Degradation of Acenaphthalene and Naphthalene under Denitrification Conditions in Soil-Water Systems. Appl. Environ. Microbiol. 54:1188-1198.

Murphy, T.P., M.E. Fox, E. Nagy, L. McArdle, A. Moller. 1990. Assessment of the coal tar contamination near Randle Reef, Hamilton. Draft Report. National Water Research Institute. Burlington, Ontario.

Pelletier J-P. 1994. Hamilton Harbour Contaminated Sediment Removal Demonstration: Report on the Water Quality Monitoring Program. Restoration Techniques Development Program. Environmental Protection Branch-Ontario Region. Environment Canada. January.

Pelletier, J-P., R. Santiago & J. Lajeunesse. 1994. Evolution of Cable Arm Clamshell Bucket. Proceedings of the Second International Conference on Dredging and Dredged Material Placement. Dredging '94. Volume 2. p.1050-1060.

Persaud, D., R. Jaagumagi and A. Hayton. 1994. Guidelines for the Protection and Management of Aquatic Sediment Quality in Ontario. Water Resources Branch, Ontario Ministry of the Environment and Energy. June.

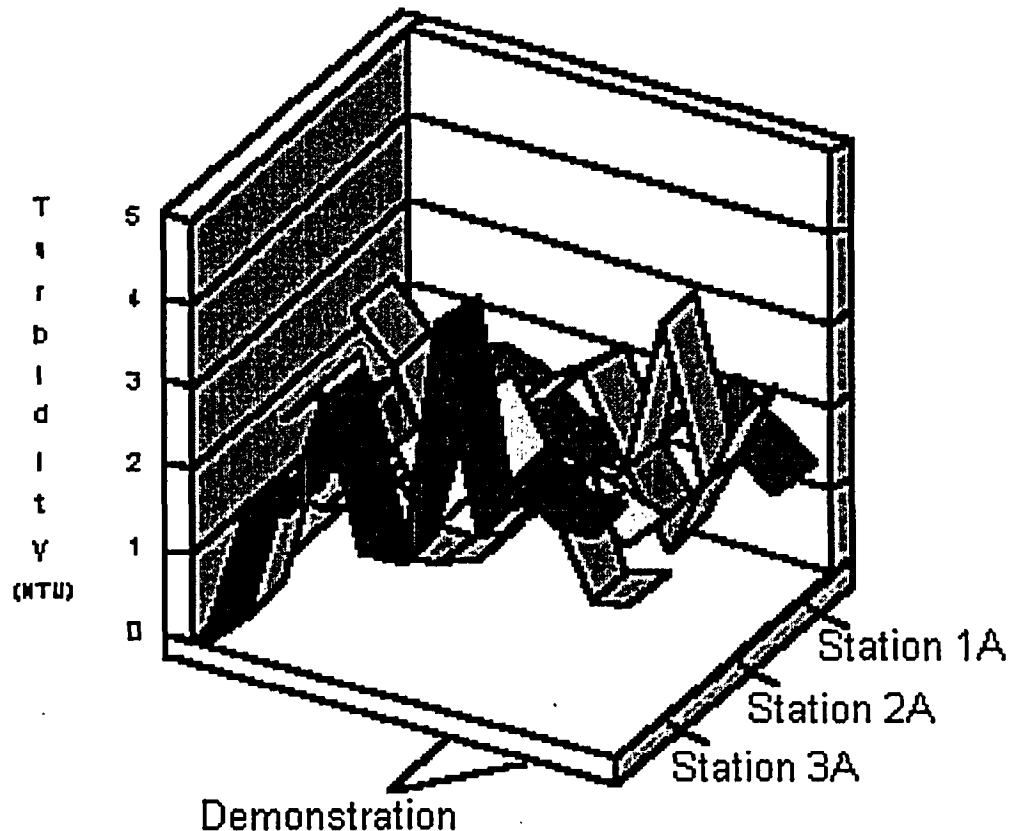

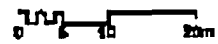
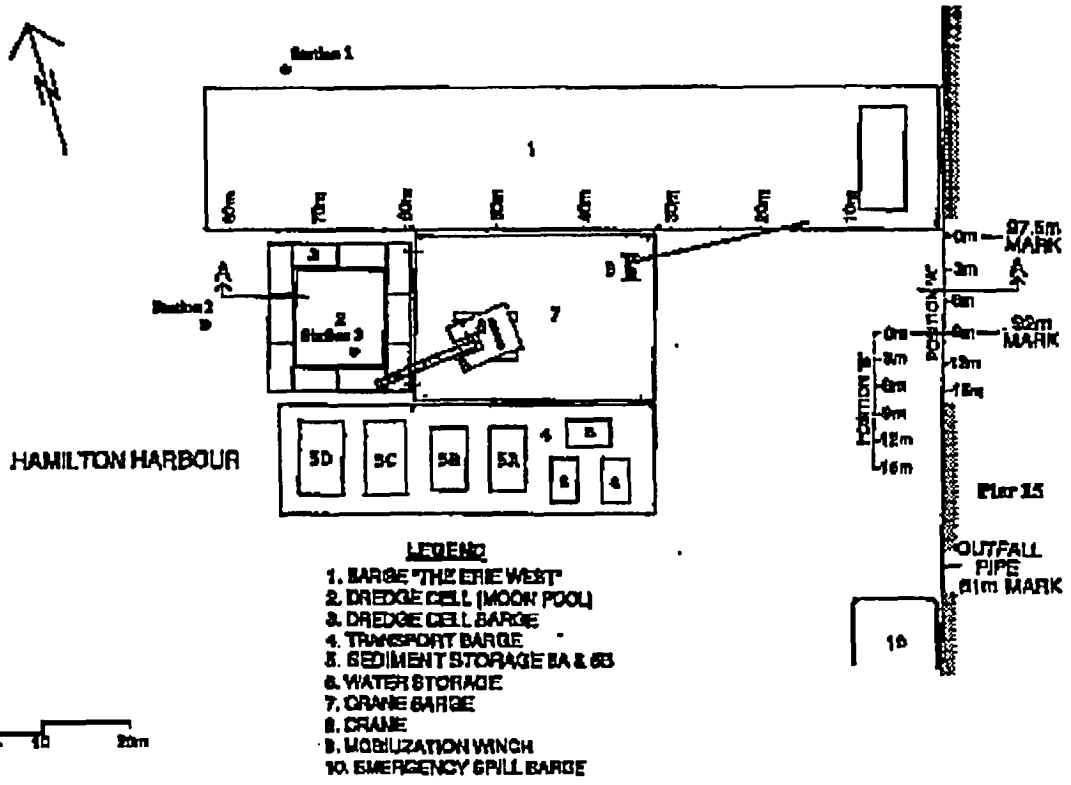
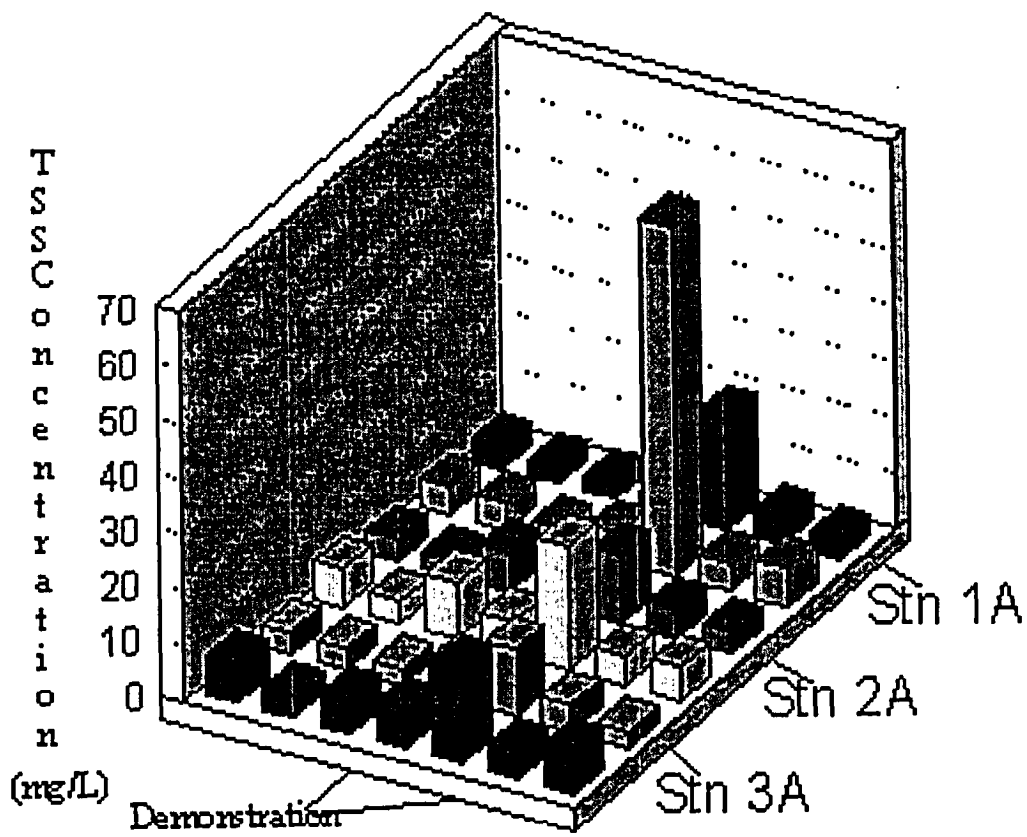

Cable Arm (Canada) Inc., Cable Arm Clamshell Bucket

22-Dec-97

Location: Toronto Harbour, Toronto, Ontario, Canada

Pilot Scale

Client/Funding Agency	Contact	Phone
Remediation Technologies Program/Great Lakes Cleanup Fund		

* Monitored * Auditor: Ian Orchard (Environment Canada) Phone: (416) 739-5874

Removal Rate(m³/hr): 22 Amount Removed In-Situ (m³): 250

Removal Cost(US\$): \$153,634.00

Mobilization (days): 5 Demobilization (days): 4

Site Conditions: After conducting a sediment sampling survey across the waterfront slips in April 1992, the Remediation Technologies Program of Environment Canada decided (based partly on the results of that survey) that Parliament Street Slip was the most suitable site for the demonstration of an innovative sediment removal technology due to the marginal sediment contamination encountered, particle size of the sediment, low usage of the slip, absence of current, and, of most importance, the absence of storm sewer outfall that would complicate post-demonstration site assessment. Bathymetric surveys performed prior to the demonstration have indicated a water depth fluctuating from 7.7 to 9.5 m.

Parliament Street slip is used during the summer by the Royal Canadian Yacht Club as a lanching basin and as a docking area for transport of merchandise and personnel to the club located on Toronto Island.

Contaminants Present:	Contaminants	Max. Concentration (ug/g, dry)	LEL (ug/g)	SEL (ug/g)
	Chromium	100	26	110
	Copper	100	16	110
	Iron	40,000	20,000	40,000
	Lead	200	31	250
	Nickel	80	16	75
	Zinc	70	120	820
	Oil & Grease	25,000	---	---

The LEL and the SEL are both guidelines established by the Ontario Ministry of the Environment & Energy for the protection and management of aquatic sediment quality in Ontario. The LEL represents the lowest concentration where a contaminant will have an effect on benthic organisms, while the SEL is the concentration where contaminants will have a detrimental effect to the majority of benthic organisms. The SEL for PAHs is also dependent on the concentration of total organic carbon.

Water Quality: Numerous water quality infractions occur across the Toronto waterfront. Ontario's Provincial Water Quality Objectives (PWQO) for nutrients and faecal coliforms are frequently exceeded. "Water Pollution Control Plants (WPCP) also known as Sewage Treatment Plants (STP) represent major sources of nutrients. Sewer systems discharging either directly or via tributaries are a major source of faecal coliform bacteria. Violations of the PWQO for metals and organics are most prevalent near point sources, river mouths and areas with poor water circulation. Away from these locations, few data exceed the PWQO, indicating little adverse impact" (RAP, 1989).

The Inner Harbour is severely affected area by runoff. The influence of runoff decreases with increasing distance from shore. Comparisons were made between general Inner Harbour and Simcoe Street Slip water quality. During dry weather, water quality in the slip was similar to that in the Inner Harbour, but during runoff conditions, high nutrient loadings were observed in the slip. The findings indicate that during dry weather, all sewage flows are diverted by interceptor sewers (RAP, 1989), but during peak runoff events, overflows are common and direct discharge to the slip occurs.

The Inner Harbour represents one of the most degraded areas with respect to water quality along the Toronto waterfront. The poor dispersion characteristics of the embayments, harbour and slips are largely responsible for the nutrient, metal, organics and bacterial contamination of this area (RAP, 1989). Highly contaminated waters from the Don River, in conjunction with numerous storm sewer outfalls and Combined Sewers Overflows distinguish the Inner Harbour from the Outer Harbour. Cadmium, copper, iron, lead, zinc and lindane concentrations exceed the PWQO near the Don River mouth.

Turbidity: Water quality monitoring program included sample runs prior, during and after the demonstration. The pre-demonstration sample runs were performed on May 8 and 14, and June 2, 1992. Sample days were both preceded by sunny days. The demonstration (June 3 & 4) runs were performed during sunny days, preceded by the same weather. Samples were also taken on June 5 (24 hours after the demonstration) during low rain. It was preceded by sunny days. Samples from the slip were also taken on June 9. This run was performed during sunny weather. Same weather was in effect the preceding days.

A 6.2 L Kemmerer sampler composed of transparent polyvinyl chloride and acrylic plastic with silicone rubber seals was used for collection of water samples. The samples were collected one meter below the water surface and one meter above the sediment surface. All bottles used for the samples were filled with one sampler load. Turbidity readings were performed in the field at each station using a Monitek nephelometer.

Three official sampling stations were chosen. Station one was located at 25 m outside the confined area

Cable Arm (Canada) Inc., Cable Arm Clamshell Bucket

22-Dec-97

(approximately 50 m from the dredge). Station 2 was located at 10 meters from the work area, while station 3 was in the work area.

Table 1 shows the variation of turbidity in Parliament Street Slip throughout the entire water quality monitoring program. It can be seen that the pre-demonstration levels for all stations were very low, approximately 2 NTU. The operational standards call for an increase in turbidity not to be higher than 30% of the background level at 25 m from the dredge. Therefore, an increase in turbidity of 0.6 NTU was to be the set limit. No sampling station was at 25m from the dredge. Station 2 was 10 m from the dredge. From Table 1, it can be seen that the level of turbidity was slightly over the 2.6 NTU limit at Station 2B on four occasions: June 3 am (4.4 NTU) and pm (4.1 NTU), on June 4 (4.0 NTU) and on June 5 (3.5 NTU). The station located 10 m from the dredge was expected to record turbidity levels over the established limit.

Table 1 shows a predictable pattern for turbidity in the dredge cell: 1) a background level comparable to other stations, 2) an increase in turbidity in the dredge cell and a level of turbidity that stays higher than outside the dredge cell throughout the entire demonstration, and 3) a decrease to background level after the demonstration. Table 1 shows that the highest level of turbidity created by the Cable Arm 100E bucket was only 10.8 NTU.

Table 1:

Averaged total suspended solids concentrations and turbidity levels measured prior, during and after the Toronto Harbour demonstration (from May 8 to June 15, 1992):

Station #	Prior		During		After	
	Turbidity (NTU)	TSS mg/L	Turbidity (NTU)	TSS mg/L	Turbidity (NTU)	TSS mg/L
1A	2.5	6.5	2.5	5.0	1.9	5.0
1B	2.2	3.5	2.5	8.0	2.8	6.0
2A	2.0	6.5	1.0	2.0	1.9	5.5
2B	2.4	8.0	2.7	5.0	2.3	4.5
3A	1.9	5.0	4.3	31.7	1.0	4.0
3B	2.8	6.5	4.6	22.0	4.3	11.0

A: sample taken 1 m from water surface, B: Sample taken 1 m from sediment, Station 1: 25 m from confined slip, Station 2: 25 m from confined work area, Station 3: in the confined work area.

Total Suspended Solids: Table 1 shows the same type of results for TSS as for turbidity: a low background concentration, an important increase in the dredge cell (Stations 3A & 3B) during the demonstration, and a decrease to background level in the dredge cell after the demonstration. This figure shows clearly that no increase in suspended material was detected outside the dredge cell. Table 1 also shows a constant decrease in TSS throughout the entire demonstration. The operator becoming more familiar with the operation of the bucket could explain these results.

The operational standards call for an increase in the concentration of total suspended solids of 25 mg/L or less at 25m from the dredge. Table 1 shows that the TSS level at Station 2, which was located at 10 m from the work area, remained constant throughout the entire demonstration.

Percent Solids: Results of the 14 May 1992 sediment sampling survey performed by the CSRП showed that the percent moisture of the in-situ sediment was between 40 and 50%, indicating a percentage of dry sediment higher than 50%. Therefore, a percentage of dry solids in the dredge spoils during the demonstration (prior to dewatering) near or better than 50% would be satisfactory.

The percentage of solids in each bucket load varied from one bucket to the other. The contractor determined that the percentage of dry solids in the sludge prior to dewatering averaged approximately 49%. This percentage of 49% dry solids in the spoils suggests that very little excess water has been added to the sediment during dredging (between 1 and 10% of the total volume).

The contractor has also calculated that the percentage of dry solids in the sludge after dewatering was approximately 70%.

Site Containment Used? No Yes

The slip was confined using a silt curtain made of Terrafix 400, and was anchored to the bottom and deployed on the inner side of the Sillery (Figure 1). The curtain was kept in place by using heavy cables passed through pockets located in the middle and bottom section of the curtain. The top section was tied to the Sillery. A floating oil boom was sewn on top of two pieces of silt curtain and attached to the bow of the Sillery and to two locations on the eastern wall of the slip. This section acted as a moveable gate to allow access from and to the Canadian Yacht Club launching ramp on the north side of the slip.

An apparatus called "Confined Work Area" was put in place in order to evaluate if full confinement would be required during work in open water. This confinement tool was composed of four pieces of 18 m x 8 m of Terrafix 400 sewn together and hung 1 meter above the water surface and 1.5 m above the slip bottom on the

Cable Arm (Canada) Inc., Cable Arm Clamshell Bucket

22-Dec-97

side of the two flat deck barges, the T-platform and the D.C. Everest to form an open working cell of 18 m x 15 m. The curtain was kept in place by means of concrete blocks tied to wires and hung on the four sides of the cell.

Exceed Set Standards? This demonstration was used to finalize operational and performance standards to be used for the audit of innovative technologies during future sediment removal demonstrations.

Description: This demonstration highlighted the need to test the Cable Arm bucket in an open water area with greater sediment contamination.

Removal Rate:

Conventional clamshell buckets are not water tight and occasion important spillage of sediment during lifting. Debris can also affect the efficiency of the dredge; if large debris are caught in the clamshell, a full load will not be achieved and a great amount of material will be re-suspended. Another adverse effect of conventional dredges is the fact that they leave depressions on the sediment surface which can enhance sediment re-suspension.

The above-mentioned problems were the driving force behind the design of the Cable Arm 100E clamshell bucket. Its different form was believed to leave a fairly flat sediment surface after completion of the work. Two other important features were added to the whole system once the final configuration was decided: 1) a soft membrane seal was incorporated along the closing face of the bucket increasing water tightness of the unit, and 2) an electronic sensor was placed on the bucket to indicate to the operator complete closure of the unit.

The presence of two containment chambers within the unit itself was another specification of the Cable Arm 100E clamshell bucket. The lower chamber was sealed, mainly for sediment, had a volume of 4.7 m³ while the upper one contained the water overlaying. This later one was not sealed, the water being able to escape through vents located on the side of the bucket.

Most of the cycles performed on 03 June 1992 were recorded with entry and removal time. The shortest cycle time recorded was 1 minute and 30 seconds, while the longest was 8 minutes and 5 seconds. From 8:20:38 to 13:43:27, thirty-two full cycles were performed (total time : 5:22:49), resulting in an average of approximately 6 full cycle/hour (10 min/cycle). This very slow cycle time was mainly due to the operator's lack of familiarity with the bucket. The production rate was estimated at 21.83 m³/hr.

Amount Removed in-situ (m³) :

The volume of wet contaminated sediment removed during the demonstration was calculated at three different stages: 1) immediately after dredging, 2) at the time of un-loading, and 3) after the demonstration using bathymetric results.

Immediately after dredging, it was assumed that, knowing the maximum volume of sediment possibly contained within the bucket is 4.7 m³, the total volume of material removed, assuming a full load for each of the 53 buckets, was :

$$53 \text{ loads} \times 4.7 \text{ m}^3/\text{loads} = 249.1 \text{ m}^3$$

The first estimate of the total volume of sediment + water removed was therefore 249.1 m³.

The second estimate was performed at the time of unloading at the treatment facility. The estimate takes into account the volume of water decanted from the sediment.

If 23 dump trucks, each having a capacity of 7 m³, have been filled to capacity, and that three bucket loads were dumped directly to the hopper barge, the total volume should be:

$$- 23 \text{ trucks} \times 7 \text{ m}^3/\text{truck} = 161 \text{ m}^3$$

$$- 3 \text{ loads} \times 4.7 \text{ m}^3/\text{loads} = 14.1 \text{ m}^3$$

Total volume of sediment and water = 175.1 m³ of sludge at approximately 70% solids.

The third method used to quantify the amount of material removed during the demonstration was through the bathymetric surveys performed before and after the demonstration. Using a software called "Surfer", the contractor estimated that the volume of sediment plus water removed was approximately 235 m³. This estimation was based on 2.5 m sounding survey grids. In order to have a better computerized estimation, a tighter survey grid should have been used.

Based on the above calculations, it can be seen that the actual quantity of sediment plus water removed from Parliament Street Slip was located anywhere between 235 and 255 m³.

Removal Cost :

The total cost of the demonstration charged by Cable Arm (Canada) Inc. was therefore 153,634.44 \$(US) to remove approximately 250 m³ (unit cost 614.53 \$(US)/m³).

The removal cost was 12,949.68 \$(US) (unit cost 51.80 \$(US)/m³). This elevated cost is mostly due to demonstration requirements such as delays caused for testing, modifications, and special requirements to dredge in contaminated sediment.

Mobilization Time (days) :

The equipment was first brought in Parliament Street Slip on May 29, 1992. Mobilization ended on June 2, at approximately 17:00. The equipment generally consisted of the following:

- A Cable Arm 100E clamshell bucket: this bucket had a maximum capacity of 4.7 m³;
- Crane (Lima 1250);
- D.C. Everest cargo ship: this vessel was used as a containment facility. The containment area was split in two: one side for sediment, and the other compartment for excess water. The total volume of the sediment containment facility was 259.2 m³;

See "Figure" (below) which illustrates plant setup and water sampling stations.

- Self propelled tank barge (Sillery): this vessel was used as the contractor's headquarters and as an emergency spill response vessel;
- Emergency vacuum truck "2000 gals";
- Two tug boats (Lac Como and Stormont);
- Two flat deck barges;
- One T-Platform;
- One motorized cable winch used to move the CWA;
- One 5 m x 2 m container used as video surveillance work station, and two other 5 m x 2 m containers used as equipment storage facilities;
- Silt curtain and oil boom.

All the above-noted equipment was placed in Parliament Street Slip as described in the "Figure" (see below). The slip was confined using a silt curtain made of Terrafix 400, and was deployed on the inner side of the Sillery.

On June 2, 1992, a remotely operated vehicle (ROV) was launched in the enclosed slip to determine if the silt curtain was properly installed (i.e. sitting on the bottom). The monitor in the ROV was able to detect areas where the curtain was not anchored properly. A diver was sent to remediate the situation in those areas requiring repair.

Demobilization Time (days) :

Removal of the equipment from the slip started on Friday, 05 June 1992. The silt curtain was salvaged after assessment of turbidity levels performed by the contractor indicated that the level in the slip was not higher than the turbidity level of the inner harbour. All the equipment, except for the D.C. Everest and the tug boats, was removed from the slip on 05 June 1992.

On 08 June 1992, the D.C. Everest containing the removed sediment was towed to the treatment facility using tug boats. Once docked at the treatment facility and after some delay, the material was unloaded to dump trucks using the Cable Arm 100E clamshell bucket. Each truck had a capacity of 7.6 m³, therefore, less than two full clamshell bucket loads were sufficient to fill the truck. In total, 23 dump trucks were filled with removed sediment. Eight of those 23 truck loads were taken to hopper barges, while the other 15 were taken to the treatment plant's storage facility. An additional 4 bucket loads were dumped directly into hopper barges. Excess material was transported to the Leslie Street Spit's Cell 2 for disposal and confinement. The excess water was pumped to the treatment facility's lagoon for treatment and discharge to the City's sewer system after all regulations have been met.

Regulatory Approvals :

As part of the demonstration project, several approvals and permits were required from various departments of the federal government and property owners affected by the project. Since Toronto Harbour is a federal port, provincial permits and approvals were not required. Even though their approval was not necessary, the provincial Ministries of Environment and Energy and Natural Resources and the Metropolitan Toronto and Region Conservation Authority were involved in the planning and the decision making process related to the demonstration.

The following is a list of the necessary federal approvals, and property owners affected by the activities:

Federal Government:**Department of Fisheries and Oceans**

- a) Approval under Section 33 of the Fisheries Act.

Federal Environmental Assessment and Review Office

- a) Initial Screening of the proposal undertaking in keeping with the requirements of the federal Environmental Assessment and Review Process.
- The Toronto Harbour Commission
- a) Approval from the Harbour Master to Dredge in Toronto Harbour

Affected Property Owners:

- CanAmera Foods
- Royal Canadian Yacht Club

As part of the requirements of the Federal Environmental Assessment and Review Process, the federal agency undertaking

Cable Arm (Canada) Inc., Cable Arm Clamshell Bucket

22-Dec-97

activities on federal lands or funding a project using federal dollars is obligated to produce an Environmental Screening Document presenting the state of the environment, the projected impact of the work and the mitigative measures. This document is then sent out to different agencies for their review and comments and public approval is then sought during a public meeting.

In April 1992, an Environmental Screening Document (ESD) was prepared and sent to the Project Planning Committee and members of the public for their review and comment.

The dredging technique was explained and demonstrated. Presentation of the project by the Contaminated Sediment Removal Program, the Contaminated Sediment Treatment Program, and the contractors was undertaken prior to the project, followed by an open house. Members of the public attended, asked questions and raised their concerns. Members of the Dredging Demonstration Committee, the Toronto Harbour Remedial Action Plan Technical Committee and Public Advisory Committee was also in attendance. During the open house, draft copies of the ESD was available to the public. The final version of the ESD was sent to the reviewing committee and those members of the public who requested a copy during the open house. No questions or concerns were raised during the open house. The public also the opportunity to review the ESD.

Bibliography:

Lajeunesse, J. 1992. Contaminated Sediment Removal Demonstration of Cable Arm Clamshell in Toronto Harbour. L.B. Tanker. Report prepared for the Contaminated Sediment Removal Program of Environment Canada. November.

Metropolitan Toronto Remedial Action Plan (RAP) 1989. Metropolitan Toronto Remedial Action Plan. Report prepared jointly by Environment Canada, Environment Ontario, Ministry of Natural Resources and Metropolitan Toronto and Region Conservation Authority.

Pelletier, Jean-Pierre. 1994. Toronto Harbour Contaminated Sediment Removal Demonstration: Report on the Water Quality Monitoring Program. Restoration Techniques Development Program. Environmental Protection Branch-Ontario Region. Environment Canada. January.

Pelletier, J-P, A. Leaney-East. 1992. Parliament Street Slip Contaminated Sediment Removal Demonstration: Environmental Screening Document. Report for the Contaminated Sediment Removal Program. Environmental Protection Branch - Ontario Region. Environment Canada. May.

Royal Commission on the Future of the Toronto Waterfront (Canada). 1990. East Bayfront and Port Industrial Area: Environment in Transition. A Report on Phase I of and Environmental Audit of Toronto's East Bayfront and Port Industrial Area, The Honorable David Crombie, Commissioner. April.

Project: Clamshell Bucket Bench Scale Demonstration

Year 91

Location: Hamilton Harbour (Pier 15)

Bench Scale

Client/Funding Agency	Contact	Phone
Remediation Technologies Program/Great Lakes Cleanup Fund	Ian Orchard	(416) 739-5874

* Monitored *

Auditor: ECO LOGIC

Phone: (519) 856-9591

Removal Rate(m³/hr): Amount Removed In-Situ (m³): 8

Removal Cost(US\$): \$36,000.00

Mobilization (days): 1 Demobilization (days): 1

Site Conditions: High concentrations of PAHs and protection from wave action and boating activity were the basis for selection of this location. Sediment samples taken prior to the demonstration had visible oil and grease residues, a black colour and a slight odour. Water depth was approximately 8 m.

Contaminants Present:	Contaminants	Max. Concentration (ug/g, dry)	LEL (ug/g)	SEL (ug/g)
1) PAHs		>1200	4	1,000
2) Chromium		>110	26	110
3) Iron		>40,000	20,000	40,000
4) Zinc		>820	120	820

The LEL and the SEL are both guidelines established by the Ontario Ministry of the Environment & Energy for the protection and management of aquatic sediment quality in Ontario. The LEL represents the lowest concentration where a contaminant will have an effect on benthic organisms, while the SEL is the concentration where contaminants will have a detrimental effect to the majority of benthic organisms. The SEL for PAHs is also dependent on the concentration of total organic carbon.

Water Quality: Three of the most important water quality problems present in Hamilton are related to oxygen depletion and water clarity. These are excessive ammonia loading from primarily sewage treatment plants, phosphorus loadings from several sources, and high levels of suspended solids from industries, streams, STPs, and sewage overflows.

Ammonia concentrations are a function of loadings versus biological processes and flushing losses to Lake Ontario. The most important biological processes are bacterial nitrification and algal uptake which are processes controlled by temperature. Therefore, ammonia accumulates during the winter. The nitrification

Cable Arm (Canada) Inc., Cable Arm Clamshell Bucket

22-Dec-97

starts in the spring when the water temperature rises. In so doing, the oxygen level in the harbour water is reduced.

Although a decrease in phosphorus levels within the harbour has occurred since nutrient controls were introduced in the early 1970's. A definite decrease in phosphorus loading was noticed since 1974.

Water clarity is another problem in the harbour. Two important factors related to water clarity are the chlorophyll a and the suspended solid concentrations.

It was found that the shoreline secchi disk transparencies averaged 0.95 m but only the first 100 meters from the shore had these reduced transparencies. Any location with water depths greater than 2 m had a water clarity similar to offshore water clarity.

Other contaminants such as metals and organics play also an important role in the water quality of the harbour. The major sources of metals to the harbour are the steel industries. Since the implementation of loading reductions from the iron and steel industries in 1983/84, the average concentrations of metals meet the PWQO. The industries are also the largest dischargers of organic contaminants. The average concentrations of organic compounds meet the PWQO (when there is one).

Dissolved oxygen rapidly declines from saturation in early spring to values of 7 mg/l in the epilimnion and 1-2 mg/l in the hypolimnion during summer. Continuous monitoring of the hypolimnetic oxygen has shown the impact of oxygen-rich Lake Ontario water which flows into the hypolimnion causing concentration to oscillate daily between near anoxia to 2 and sometimes 4 mg/l.

Turbidity: Water quality measurements through the use of a secchi disk were taken immediately before and after the removal, as well as 24 and 72 hours later. The measurements indicated that a small decrease (0.5 m) in water clarity inside the confined area was observed 1 hour after the dredging took place. This indicates that the concentration of suspended material increased. This was more than likely due to the re-suspension of some bottom sediment, and/or to the release back in the confined area of the first scoop of dredged material when debris prevented complete seal of the bucket. Twenty-four hours after removal, water clarity (measured through secchi disk depth) was back to pre-demonstration conditions. The water clarity outside the confined area did not change during the removal operation.

Total Suspended Solids: Water quality measurements through the use of a secchi disk were taken immediately before and after the removal, as well as 24 and 72 hours later. The measurements indicated that a small decrease (0.5 m) in water clarity inside the confined area was observed 1 hour after the dredging took place. This indicates that the concentration of suspended material increased. This was more than likely due to the re-suspension of some bottom sediment, and/or to the release back in the confined area of the first scoop of dredged material when debris prevented complete seal of the bucket. Twenty-four hours after removal, water clarity (measured through secchi disk depth) was back to pre-demonstration conditions. The water clarity outside the confined area did not change during the removal operation.

Percent Solids: Not available

Site Containment Used? No Yes

A curtain consisting of a polyester weave tarp-like material measuring 9 m by 9 m was installed. A looped seam along the length on one side was used to carry a heavy chain as an anchor, and eyelets on the other side were used to hold up the top of the curtain using rope. After installing the chain and rope with the curtain fully extended, a crew of ten carried it to the edge of the inlet where it was attached to a small boat. The boat first deployed the curtain straight out from the shore, until the entire length was in the water. The top of the curtain was then fastened to the barge, and the boat slowly circled back to deploy the curtain in a closed U-shape against the shore. An anchored pontoon raft was used to secure the other corner of the U-shape.

Exceed Set Standards? Not applicable

Description: In early 1990, the Contaminated Sediment Treatment Technology Program (CoSTTeP) received a proposal for the demonstration of innovative treatment technology by ECO LOGIC. After negotiations and laboratory demonstrations of the hazardous waste destructor, the CoSTTeP accepted to fund, in part, a demonstration of this treatment technology on contaminated sediments from Hamilton Harbour.

The main objectives of this removal demonstration was to provide material to the Eco Logic process, but also to allow the Remediation Technologies Program to develop standards and procedures for future demonstration projects.

Removal Rate: not applicable

Removal Cost :

The total cost of this project was 36,000 \$(US) (unit cost 4,500\$(US)/m³). This high cost was mostly due to very low volume required demonstration and Health and Safety requirements.

Regulatory Approvals :

Canadian Coast Guard, Department of Transport:

Approval to "Dredge in a Navigable Waterway under Section 5(2) of the Navigable Waters Protection Act, RSC 1985, Chapter N-22".

Department of Fisheries and Oceans:
Approval under Section 33 of the Fisheries Act.

Federal Environmental Assessment and Review Office:
Initial Screening of the proposal undertaking in keeping with the requirements of EARP.

Approval from Hamilton Harbour Commission:
Hamilton Harbour being a Federal harbour, only federal approvals were required. Provincial concurrence was also requested.

Bibliography:
ELI Eco Logic International Ltd.. 1991. Pilot-Scale Demonstration of Contaminated Harbour Sediment Treatment Process. Report prepared for the Contaminated Sediment Treatment Technologies Program, Wastewater Technology Centre. November. (Draft).

Pelletier, J-P., R. Santiago & J. Lajeunesse. 1994. Evolution of Cable Arm Clamshell Bucket. Proceedings of the Second International Conference on Dredging and Dredged Material Placement. Dredging '94. Volume 2. p.1050-1060.

Technology Type: Hydraulic

System Works With: Debris, Strong Currents, Water Depth 2-10m

Development Stage: Commercial

Country Of Origin: England

Description:

Removal of contaminated or non-contaminated siltation at concentrations up to 95% solids from depths down to 200 m and discharging at low velocities through pipelines up to 1000 m. Conbar International has over 35 years of research and development experience in the dredging field.

Environmental Dredger "EV":

- siltation removal (without water)
- removal of hydrosol without moisture
- up to 80/90 per cent concentration of solid material
- no winch wires required
- self propelled
- one man operation
- automatic adjusting
- environmentally acceptable in confined places
- reservoir desilting with minimum water removal
- canal cleaning
- able to work in less than 0.8 m of water
- running costs less than any other known system
- acoustically covered for noise control
- full service backup
- low thrust for towing oil recovery booms
- surface rubbish removal

General Description:

The machine is designed to dredge solid siltation and sands with a maximum stone size up to 50 mm, and with the minimum of water. It can dredge up to 80/90% concentration of solid material and remove hydro soil at a controlled rate (which is essential in the de-silting of reservoirs and canals, etc).

To enable the machine to be completely mobile and able to work in the close environments where the use of anchors and winch wires are prohibited, specially designed thruster units are fitted to provide the thrust for dredging in water. These units can also be used in the local propulsion of the unit.

Where water levels are limited, dredging can still be achieved by the use of the variable speed screw head with an automatic adjusting ability.

The machine is of one man operation, with a possible "in built" characteristic of becoming computer controlled for operation in environments where manual operators are prohibited. The fitting of tracks can be undertaken for the dredging of canals, etc., where water is limited. The head unit of the machine can be removed and used with other heavy duty plants such as backhoes, cranes and grab type dredgers for such operations as ditch dredging.

Brief Technical Description:

Overall Length:	14.3 m	Mean Draught:	0.8 m
Overall Height:	3.3 m	Max. Dredge Depth:	7.0 m
Hull Length:	13.0 m	Total Weight:	25 tonnes
Hull Width:	3.5 m	External Pipeline:	153 mm
Hull Depth:	1.35 m	Internal Pipeline:	178 mm

Limitations:

Type of Power: Diesel/Hydraulic/Positive Displacement

Government Funding:

Environmental Concerns:

Health & Safety Plan Available:

Regulatory Approvals Obtained for U.K.; Venice; Italy

Setup/Feed: Mobilization (days): 2

Demobilization (days): 1

Removal Rate Average (m³/hr): 150

Cost: Capital Cost (US\$):

Conbar International, Environmental Dredger

22-Dec-97

Unit Cost (US\$/m³): \$3.00 – \$25.00 Average Cost (US\$/m³): \$5.00

Developers:

Conbar International (Marine Consultants) Ltd.

Harbour Point Victoria Parade

Torquay, Devon

England TQ1 2BD

Notes

Contact: Bartlett, D. S.

Phone: 01803213636

Fax: 01803212502

Email:

Ext:

Vendors:

Conbar International (Marine Consultants) Ltd.

Harbour Point Victoria Parade

Torquay, Devon

England TQ1 2BD

Notes

Contact: Bartlett, D. S.

Phone: 01803213636

Fax: 01803212502

Email:

Ext:

Literature References:

Author:

Title:

Journal:

Date:



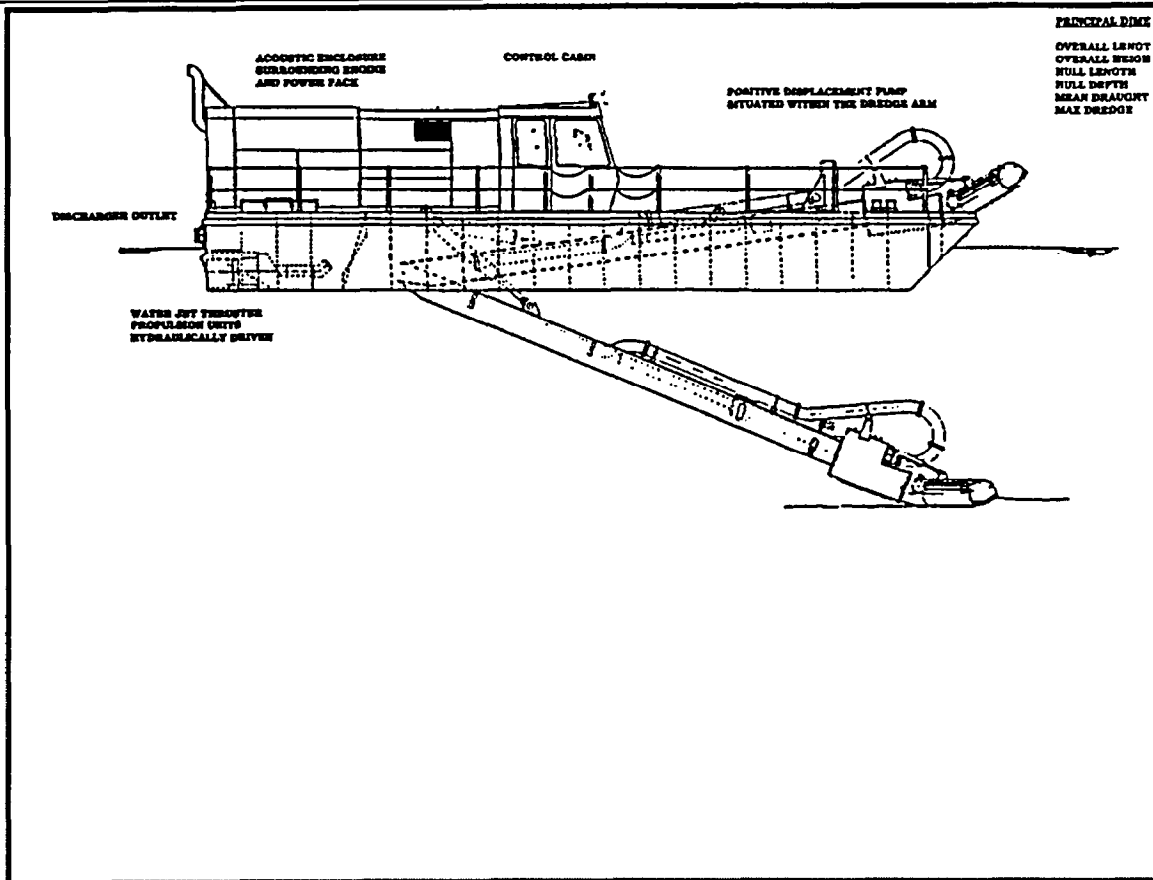

Project: Canals of Venice

Location: Venice, Italy

Year 93

Pilot Scale

Client/Funding Agency	Contact	Phone
Private		

Not Monitored

Removal Rate(m³/hr): 105 Amount Removed In-Situ (m³): 45000

Removal Cost(US\$):

Mobilization (days): Demobilization (days): 1

Site Conditions: Flat site conditions.

Contaminants Present: Arsenic (10 ug/g); Manganese (126 ug/g)

Water Quality: Poor

Turbidity: Level

Total Suspended Solids: 50% (by weight)

Percent Solids: 50/70" CW

Site Containment Used? No Yes

Exceed Set Standards?

Description: Site: Outer Canal (San Francisco) Venice. Pumping Distance: 1000 m. Dredge depth: 6 m. Removal rate: 100 - 110 m³/hour. Removal cost: \$3.50 US/hour. Mobilization time: 3 hours. Demobilization: 1 day.

Cosolidated Dewatering Inc., Dewatering

22-Dec-97

TechID: 343

Technology Type: Hydraulic

System Works With: Debris, Water Depth 2-10m, Water Depth < 2m

Development Stage: Commercial

Country Of Origin: Canada

Description:

Environmental hydraulic dredging, using patented low turbidity auger head for dredging and high "G" centrifuge for separation of sludge and water.

Technology still under development - no project information yet available.

Limitations:

Type of Power: Diesel and Electric

Government Funding:

Environmental Concerns:

Health & Safety Plan Available:

Regulatory Approvals

Setup/Feed: Mobilization (days):

Demobilization (days):

Removal Rate Average (m³/hr): 45

Cost: Capital Cost (US\$):

Unit Cost (US\$/m³): \$100.00 - \$300.00

Average Cost (US\$/m³): \$200.00

Developers:

Consolidated Dewatering Inc.

39 Reid St., P.O.B. 163

Charlo, NB

Canada

E0B1M0

Notes

Contact: Hebert, Marc

Phone: (506) 684-2163

Ext:

Fax: (506) 684-1915

Email:

Vendors:

Consolidated Dewatering Inc.

39 Reid St., P.O.B. 163

Charlo, NB

Canada

E0B1M0

Notes

Contact: Hebert, Marc

Phone: (506) 684-2163

Ext:

Fax: (506) 684-1915

Email:

Literature References:

Technology Type: Hydraulic

System Works With: Strong Currents, Water Depth 2-10m, Limited Shore Access

Development Stage: Commercial

Country Of Origin: USA

Description:

Utilizing both specialized equipment and technologies to capture high solids without resuspension.

CP Environmental also offers the following:

FLUMP: The Mini-Dredger for your smallest ponds; quiet, remote controlled operation; ideal for situations where an operator on the pond is not desirable.

RODOMITE: For high-solids waste; self-propelled to allow maneuvering and dredging without a cabling system.

SLUDGE DREDGE: The largest units in our fleet, high volume production at dredging depths to 6 m.

Limitations:

Type of Power: Diesel/Hydraulic

Government Funding: Superfund

Environmental Concerns: Hydraulic fluid is environmentally safe.

Health & Safety Plan Available:

Regulatory Approvals: As required for sites.

Setup/Feed: Mobilization (days): 1

Demobilization (days): 1

Removal Rate Average (m³/hr): 300

Cost: Capital Cost (US\$): \$300,000.00

Unit Cost (US\$/m³): \$1.25 – \$18.00

Average Cost (US\$/m³): \$3.50

Capital cost is only if were to buy all equipment on site.

Developers:

CP Environmental Inc.

P.O.B. 1348

Glendive, MT

USA

59330-1348

Notes This developer/vendor serves United States region.

Contact: Tobin, Mark

Phone: (406) 365-8371

Ext:

Fax: (406) 365-8088

Email:

SRS Crisafulli

P.O.B. 1051

Glendive, MT

USA

59330-

Notes

Contact: Lundman, Maureen

Phone: (406) 365-3392

Ext:

Fax: (406) 365-8088

Email:

Vendors:

CP Environmental Inc.

P.O.B. 1348

Glendive, MT

USA

59330-1348

Notes This developer/vendor serves United States region.

Contact: Tobin, Mark

Phone: (406) 365-8371

Ext:

Fax: (406) 365-8088

Email:

SRS Crisafulli

P.O.B. 1051

Glendive, MT

USA

59330-

Notes

Contact: Lundman, Maureen

Phone: (406) 365-3392

Ext:

Fax: (406) 365-8088

Email:

Literature References:

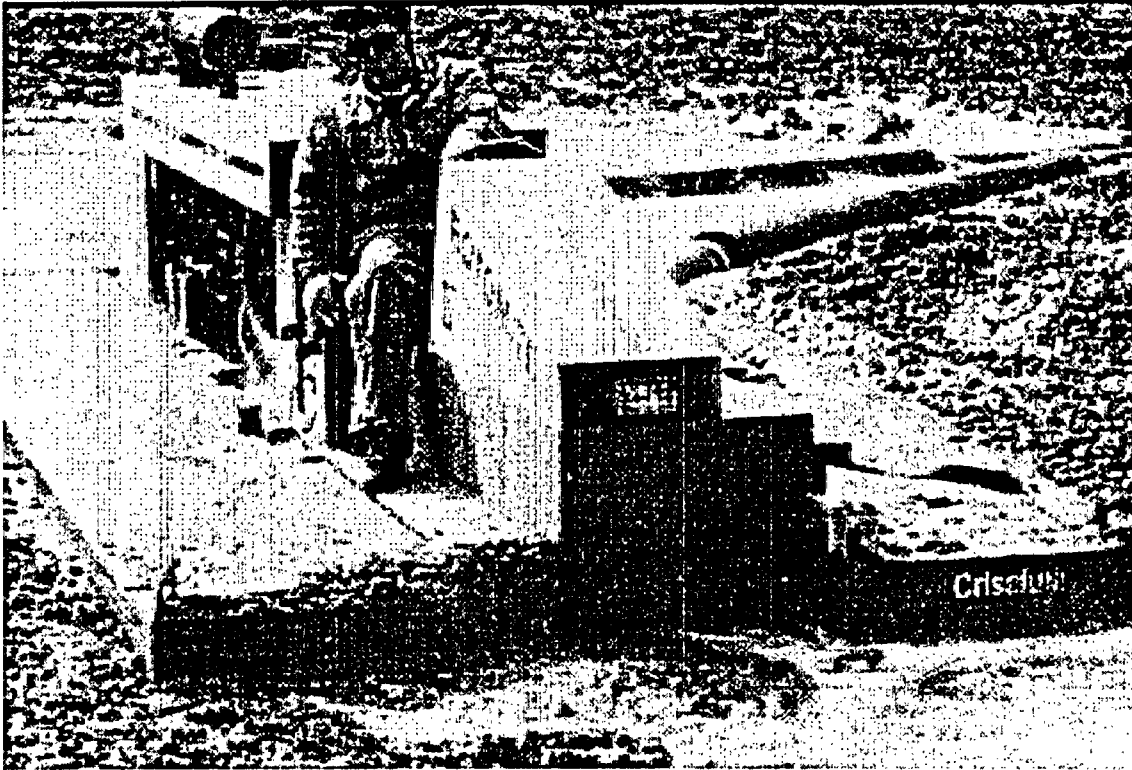

CP Environmental Inc., Non-Resuspension of Solids During Subaqueous Removal

22-Dec-97

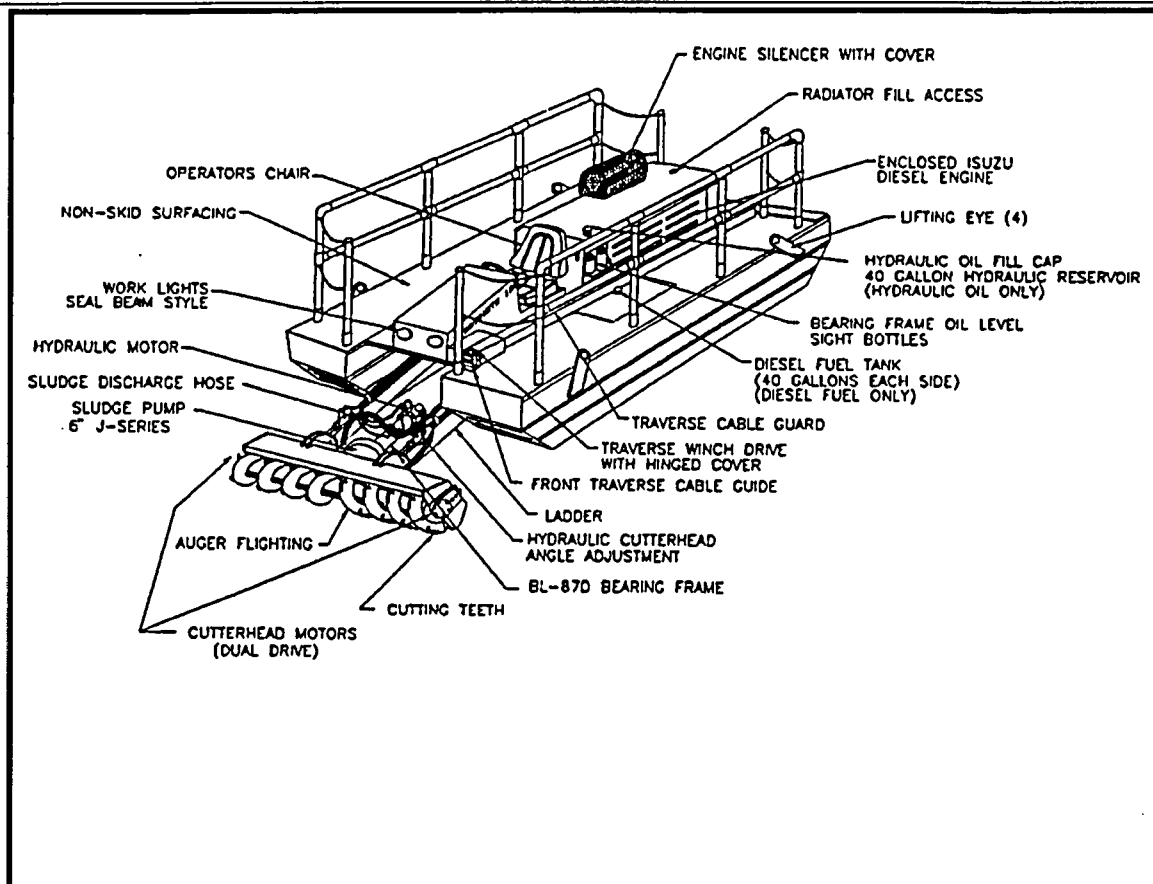

CP Environmental Inc., Non-Resuspension of Solids During Subaqueous Removal

22-Dec-97

Project: Exhibit D

Location: ,Virginia, USA

Year 94

Full Scale Demo

Client/Funding Agency	Contact	Phone
Confidential	Mark Tobin	(403) 365-8371

Not Monitored

Removal Rate(m³/hr): Amount Removed In-Situ (m³):

Removal Cost(US\$):

Mobilization (days): Demobilization (days):

Site Conditions:

Contaminants Present: Hard packed sand; light organic sediment.

Water Quality: The dissolved oxygen level was 6.6 - 9.4 mg/l (same as background). It increased as dredging continued.

Turbidity:

Total Suspended Solids:

Percent Solids:

Site Containment Used? No Yes

Exceed Set Standards? All regulatory agencies and homeowners were pleasantly surprised with the exceptional results.

Description: This project was the cleaning of a channel in a small creek. The channel is the access for home owners to the bay and the breeding area for many of the water-borne wildlife. If during the dredging operation the amount of resuspended particles depleted the oxygen levels below certain levels, it would have had an adverse effect on the wildlife. With the varying types of material requiring removal, dredging operational procedures had to be changed during the project. Results: The channel was dredged of heavy and light material without resuspension or adverse impact on the dissolved oxygen levels.

Project: Exhibit C

Location: ,Texas, USA

Year 93

Full Scale Demo

Client/Funding Agency	Contact	Phone
Confidential	Mark Tobin	(403) 365-8371

Not Monitored

Removal Rate(m³/hr): Amount Removed In-Situ (m³):

Removal Cost(US\$):

Mobilization (days): Demobilization (days):

Site Conditions:

Contaminants Present: Coal

Water Quality:

Turbidity:

Total Suspended Solids: 3.5 - 23 mg/l (Same as background).

Percent Solids:

Site Containment Used? No Yes

Exceed Set Standards? The results were well within standards.

Description: Objective: to recapture coal from lake and stack on shore for use in plant. A large portion of the coal was in the flow path of the intake structure. The power plant had stock piles of coal close to the cooling water lake. Some of the coal washed down and into the lake. The critical operating parameter was to remove the coal from the lake without resuspension which would adversely effect the quality of the water. Samples were taken at the plant intake structure during the dredging operation. Dredging at the time of samples was within 15 m of the intake structure and in the flow pattern. Samples were taken three times on the first day, and once a day for the next six days. Sampling was discontinued because of the favorable sampling results in the area closest to the intake structure and the fact that as the job progressed the process moved farther from the intake.

Project: Exhibit B

Location: ,Texas, USA

Year 92

Full Scale Demo

Client/Funding Agency	Contact	Phone
Confidential	Mark Tobin	(403) 365-8371

Not Monitored

Removal Rate(m³/hr): Amount Removed In-Situ (m³):

Removal Cost(US\$):

CP Environmental Inc., Non-Resuspension of Solids During Subaqueous Removal

22-Dec-97

Mobilization (days): Demobilization (days):
 Site Conditions:
 Contaminants Present: Mill scale build-up.
 Water Quality:
 Turbidity:
 Total Suspended Solids: When dredging in normal operating mode, kept TSS between 170 and 290 (within background).
 Percent Solids:
 Site Containment Used? No Yes
 Exceed Set Standards?

Description: Objective: To remove a mill scale (heavy specific gravity - 2.5 to 3.5) build-up in the primary settling basin and pump the material to a 48 cm plant sewer drain 35 m away. The critical operating parameter was non-resuspension of solids during dredging which would raise the amount of oil and solids discharged from the pit. The mill wanted to keep the TSS below 350 ppm and this was the highest level that was reached, even when dredging as aggressively as possible (outside normal dredging procedures).

Project: Exhibit A

Location: New Jersey, USA

Year 91
Full Scale Demo

Client/Funding Agency	Contact	Phone
Confidential	Mark Tobin	(403) 365-8371

Not Monitored

Removal Rate(m³/hr): Amount Removed In-Situ (m³):
 Removal Cost(US\$):
 Mobilization (days): Demobilization (days):
 Site Conditions:
 Contaminants Present: Build-up of alum sludge.
 Water Quality: The plant was picking up high turbidity water due to a sludge buildup upstream and around their intake structure.
 Turbidity: 1.8 - 3.0. Reduced monthly average from 3.4 to 2.1.
 Total Suspended Solids:
 Percent Solids:
 Site Containment Used? No Yes
 Exceed Set Standards?

Description: Objective: Remove the buildup of alum sludge with a specific gravity of 1.03 to 1.1 around the plant's main intake structure to eliminate the resuspension of solids from the flow patterns. The plant could not be shut down, therefore the dredging had to be done with the plant intake structure operating with flows of over one million gallons per day. The critical operating parameter was non-resuspension of solids during dredging which would raise the TSS levels in the inflow and adversely effect plant operations.

Dosco Klein Baggerwerken B.V., Scraper Dredge

21-Jan-98

TechID: 256

Technology Type:

Specialty dredge.

System Works With:

Development Stage: Commercial

Country Of Origin: The Netherlands

Description:

The DOSCO scraper dredge is a specially designed dredge capable of removing the top layer of contaminated sediment or sludge from ditches, lakes, canals, etc., with minimal sediment resuspension. The sediment or sludge is dredged by means of a closed transporting system, consisting of scrapers mounted upon a chain, which brings the dredged material to a funnel. A pump is used to finally remove the dredged material.

The effectiveness of the dredge is as follows:

- there is no disturbance of the surrounding water
- there is no contamination of non-polluted material with contaminated material
- a high capacity is reached

The thickness of the dredged layer can be varied between 0.18 to 0.3 m. The DOSCO scraper dredge is easily transportable.

Limitations:

Type of Power:

Government Funding:

Environmental Concerns:

Health & Safety Plan Available:

Regulatory Approvals

Setup/Feed: Mobilization (days):

Demobilization (days):

Removal Rate Average (m³/hr):

Cost: Capital Cost (US\$):

Unit Cost (US\$/m³):

Average Cost (US\$/m³):

Developers:

Dosco Klein Baggerwerken B.V.

West 14C - 1633 JB Avenhom

The Netherlands

Notes

Contact:

Phone: (312) 294-3200

Ext:

Fax: (312) 294-3413

Email:

Literature References:

Dredging International, Scoop Dredge BRABO

22-Dec-97

TechID: 265

Technology Type: Hydraulic

System Works With: Debris, Water Depth 2-10m

Development Stage: Pilot Scale

Country Of Origin: Belgium

Description:

The Scoop dredge BRABO consists of a two-sided functional draghead, mounted to allow dredging in two opposite swing directions. This is achieved in practice by the use of a turning blade that scrapes the material from the sediment bottom into the suction head of the dredge. At the end of the swing, the blade is turned in the opposite direction, the dredge walks forward (between 1.5 and 2.5 m) and the draghead continues scraping in the opposite direction. This Scoop-head has no rotating cutting devices, so turbidity and addition of transport water is minimized.

The Scoop dredge BRABO combines the main characteristics from the draghead of a trailing hopper suction dredger (low turbidity, high density and with no rotating device) and the movement and pumping characteristics of a cutter suction dredger (accurate horizontal and vertical positioning, no rehandling and reclamation through a closed pipeline).

The productivity is at a competitive level to other dredging traditional dredging equipment (cutters, trailers).

The Scoop dredge BRABO can work at depths varying from 3 to 28 m, the angle of the scoop-head with the ladder is adjustable with the help of the support frame.

The Scoop dredger is a promising development for the removal of soft, fine-grained material with a minimum of environmental disturbance.

Limitations: Works at depths varying from 3 - 28 m.

Type of Power:

Government Funding:

Environmental Concerns:

Health & Safety Plan Available:

Regulatory Approvals

Setup/Feed:	Mobilization (days):	Demobilization (days):
	Removal Rate Average (m³/hr):	
Cost:	Capital Cost (US\$):	
	Unit Cost (US\$/m³):	Average Cost (US\$/m³):
	\$2.00 – \$5.00	\$3.50

Developers:

Dredging International
Haven 1025-Scheldedijk 30
,
Belgium
Notes

Contact: Standaert, Peter
Phone: (323) 252-1211 **Ext:**
Fax: (323) 252-6831
Email:

Vendors:

Dredging International
Haven 1025-Scheldedijk 30
,
Belgium
Notes

Contact: Standaert, Peter
Phone: (323) 252-1211 **Ext:**
Fax: (323) 252-6831
Email:

Literature References:

Dredging Specialists, Hydraulic Dredges

22-Dec-97

TechID: 347

Technology Type: Hydraulic

System Works With: Water Depth 2-10m, Limited Shore Access, Water Depth <2m, Water Depth > 10m
Need at least 60 cm of water.

Development Stage: Commercial

Country Of Origin: USA

Description:

Dredging Specialists is a dredging contractor and builder of hydraulic dredges. Exclusive features are: 1) 4-Cable Positioning and propelling system - this provides accurate positioning of dredge at all times, which keeps pump suction in the material to be pumped and not water (therefore higher percent solids). 2) Design 8 head and underwater pump - no rotating mechanical devices to cause excessive turbidity. Moldboards direct material into pump inlet. Full production in both left and right swings. 3) Pinch Valve System - One of the major sources of turbidity is backflow in the pipeline when the pump is shut off with pipeline full. When our pump is stopped, a pinch valve pinches a hose closed at the pump discharge. This prevents backflow and turbidity.

Dredging Specialists has been in business since 1974. We have completed 150 contract projects in 19 U.S. states. We have designed and built seven hydraulic dredges for their use and sale.

Limitations: For sludge and soft sediments.

Type of Power: Diesel over hydraulic

Government Funding:

Environmental Concerns: Possibly silt curtains.

Health & Safety Plan Available:

Regulatory Approvals

Setup/Feed: Mobilization (days): 10
Removal Rate Average (m³/hr): 275

Demobilization (days): 6

Cost: Capital Cost (US\$): \$25,000.00
Unit Cost (US\$/m³): \$7.00 - \$10.00

Average Cost (US\$/m³): \$8.00

Unit costs apply if contract dredging \$140,000 to \$200,000. Capital cost for Mob/Demob.

Developers:

Dredging Specialists

43 Dewitt Ave.
Mattoon, IL
USA 61938-
Notes

Contact: Searles, Don

Phone: (217) 234-3344 Ext:
Fax: (217) 234-3347
Email:

Vendors:

Dredging Specialists

43 Dewitt Ave.
Mattoon, IL
USA 61938-
Notes

Contact: Searles, Don

Phone: (217) 234-3344 Ext:
Fax: (217) 234-3347
Email:

Literature References:

Author: Searles, D.
Title: The Fundamentals of Hydraulic Sludge Dredging
Journal:

Date: Jan 1987



Project: Baxter Water Treatment Plant

Location: Philadelphia, PA, USA

Year 94

Full Scale Demo

Client/Funding Agency	Contact	Phone
City of Philadelphia, PA	Gary Williamson	(215) 331-8146

Not Monitored

Removal Rate(m³/hr): 275 Amount Removed In-Situ (m³): 420000

Removal Cost(US\$): \$1,925,000.00

Mobilization (days): 10 Demobilization (days): 6

Site Conditions: Water velocity 0 to 1 m/s. Water depth 7.8 m sediment. Thickness 0 -1 m.

Contaminants Present: None

Water Quality: Plant remained operational while dredging within 17 m of intake without any turbidity control.

Turbidity: Not measured.

Total Suspended Solids:

Percent Solids: 20% to 30%

Site Containment Used? No Yes

Exceed Set Standards? None. Regulatory Approvals: PA - EPA; NJ - EPA.

Description: A hydraulic dredge was used to remove ferric-chloride contaminated sediment form a settling pond to barges for transport to a holding facility. 150 similar projects of this nature have been completed.

See Publications: 1) "Fundamentals of Hydraulic Sludge Dredging" 2) "Design 8 Head and Slurry Pinch Valve 3) "Four Cable Positioning and Underwater System"

Dredging Supply Company, Barracuda/Piranha/Shark

22-Dec-97

TechID: 273

Technology Type: Hydraulic

System Works With: Debris, Strong Currents, Water Depth 2-10m

Development Stage: Commercial

Country Of Origin: USA

Description:

DSC's Barracuda class portable cutterhead dredge offers what no other production dredges can offer: conventional dredging with spuds and wires and articulating ladder operation with no external wires or cables. With its ability to change from conventional operation to articulating ladder operation in minutes and its wide range of discharge sizes, 15 cm through 25 cm, the Barracuda is suitable for contracting, dock work, marinas, etc.

DSC's Piranha class portable dredge offers the ultimate in portability for a true cutterhead dredge. This small rugged dredge is available in 15 cm and 20 cm sizes and is standard with a 6.7 m cutterhead ladder and 20 cm spuds.

The Shark class dredge has a 25 cm discharge, 20 cm spuds and 9.4 m cutterhead ladder. It as a highly portable cutterhead dredge designed for the demanding requirements of contractors and mining operations.

Limitations:

Type of Power: Diesel hydraulic, diesel electric, electric, centr. pump, positive displacement pump.

Government Funding:

Environmental Concerns:

Health & Safety Plan Available:

Regulatory Approvals

Setup/Feed: Mobilization (days): Demobilization (days):

Removal Rate Average (m³/hr):

Cost: Capital Cost (US\$): Unit Cost (US\$/m³): Average Cost (US\$/m³):

Developers:

Dredging Supply Company, Inc.
5700 Citrus Blvd., Suite A-2
Harahan, LA
USA 70123-
Notes

Contact: Wetta, Thomas
Phone: (504) 733-7400 Ext:
Fax: (504) 733-0500
Email:

Vendors:

Dredging Supply Company, Inc.
5700 Citrus Blvd., Suite A-2
Harahan, LA
USA 70123-
Notes

Contact: Wetta, Thomas
Phone: (504) 733-7400 Ext:
Fax: (504) 733-0500
Email:

Literature References:

Eagle Iron Works, Swintek Dredge Ladder

29-Dec-97

TechID: 334

Technology Type: Hydraulic, Mechanical

System Works With: Water Depth 2-10m
Shallow water

Development Stage: Commercial

Country Of Origin: USA

Description:

The Swintek dredging ladder was developed for the commercial mining of sand and gravel. A moving chain passes before the inlet of a suction nozzle removing oversized materials from the inlet. Cutter bars on the chain dig into deposits and loosen material for suction. The cutter bars are also useful for cutting through tough clay seams.

Chain available in 20 cm pitch (12 cm x 12.5 cm openings), 23 cm pitch (14 cm x 14 cm openings), and 26.5 cm pitch (19 cm x 19 cm openings). Standard ladders available in 1.5 m increments, from 50 cm to 250 cm long, special ladders quoted on request. 20 cm to 45 cm pump service available.

Not previously used for remediation work.

Limitations: A 30 m ladder at 60° has a maximum mining depth of approximately 25 m.

Type of Power: Diesel, Hydraulic, and Electric

Government Funding:

Environmental Concerns: Not a concern in mining applications. Operated only in ponds.

Health & Safety Plan Available:

Regulatory Approvals

Setup/Feed: Mobilization (days):

Demobilization (days):

Removal Rate Average (m³/hr):

Cost:

Capital Cost (US\$):

Unit Cost (US\$/m³):

-

Average Cost (US\$/m³):

Average cost: US\$ 90,000.00. Standard ladder, 30 m long, 23 cm pitch chain, 35 cm suction, gear reducer included, motor and v-belt drive not included.

Developers:

Eagle Iron Works

P.O.B. 934

Des Moines, Iowa

USA

90304-0934

Notes

Contact: Wheeler, Jon

Phone: (515) 243-1123

Ext:

Fax: (515) 243-8214

Email:

Vendors:

Eagle Iron Works

P.O.B. 934

Des Moines, Iowa

USA

90304-0934

Notes

Contact: Wheeler, Jon

Phone: (515) 243-1123

Ext:

Fax: (515) 243-8214

Email:

Literature References:

Technology Type: Hydraulic

System Works With: Water Depth 2-10m, Water Depth < 2m, Water Depth > 10m

System operates in various conditions and sea states.

Development Stage: Commercial

Country Of Origin: USA

Description:

Ellicott Machine Corporation manufactures a variety of portable dredges capable of contaminated sediment dredging. These include the Mudcat line which use low speed horizontal augers, limiting turbidity. Specially developed shielded auger heads were developed purposely for dredging contaminated sediments. A variety of specialized auger, bucketwheel, and cutterhead designs exist for minimizing turbidity during contaminated sediment dredging. One design uses a vibrating suction head to penetrate material and feed to a positive displacement high solids output pump. Ellicott dredges are available with digging depths ranging from within a meter or two for shallow applications up to 3 m for deep projects.

EMC manufactures a wide range of auger dredges for shallow draft projects including industrial and municipal waste ponds and canals to large (over 75 cm) pipeline dredges for maintenance and capital dredging. Custom features can be designed and included for special project needs.

Limitations:

Type of Power: Diesel Hydraulic/Diesel Electric/Electric Hydraulic/Electric

Government Funding: Great Lakes Cleanup Fund

Environmental Concerns: Equipment provides low turbidity.

Health & Safety Plan Available:

Regulatory Approvals: Normal dredging permits.

Setup/Feed: Mobilization (days): 7

Demobilization (days):

Removal Rate Average (m³/hr): 15

Cost: Capital Cost (US\$):

Unit Cost (US\$/m³): \$10.00 – \$20.00

Average Cost (US\$/m³): \$15.00

Ellicott International: Generally, to complete a contaminated sediment dredging job versus non-contaminated material, equipment and related costs double. Lease and purchase dredge plans are offered.

	Min.	Max.	Avg.
Ellicott Machine Corp.	10.00	20.00	15.00
Consolidated Giroux Environment Inc.	1.50	3.00	2.25

Developers:

Ellicott International

1611 Bush Street

Baltimore, MD

USA

21230-2093

Notes Home Page: <http://www.charm.net/~dredge/>

Contact: Bond, Ed

Phone: (410) 545-0220

Ext:

Fax: (410) 545-0293

Email: dredge@dredge.com

Vendors:

Ellicott International

1611 Bush St.

Baltimore, MD

USA

21230-

Notes Home Page: <http://www.charm.net/~dredge/>

Contact: Smunu, Charles A.

Phone: (410) 545-0219

Ext:

Fax: (419) 545-0293

Email: dredge@dredge.com

Consolidated Giroux Environment Inc.

39 Reid St., P.O.B. 163

Charlo, NB

Canada

E0B1M0

Notes

Contact: Rousselle, Eugene

Phone: (506) 684-5821

Ext:

Fax: (506) 684-1915

Email:

Auburn Contractors
166 Douglas St. W.
Sudbury, ON
Canada P3E1G1
Notes

Contact: McKinty, D.A. Sandy
Phone: Ext:
Fax:
Email:

Literature References:

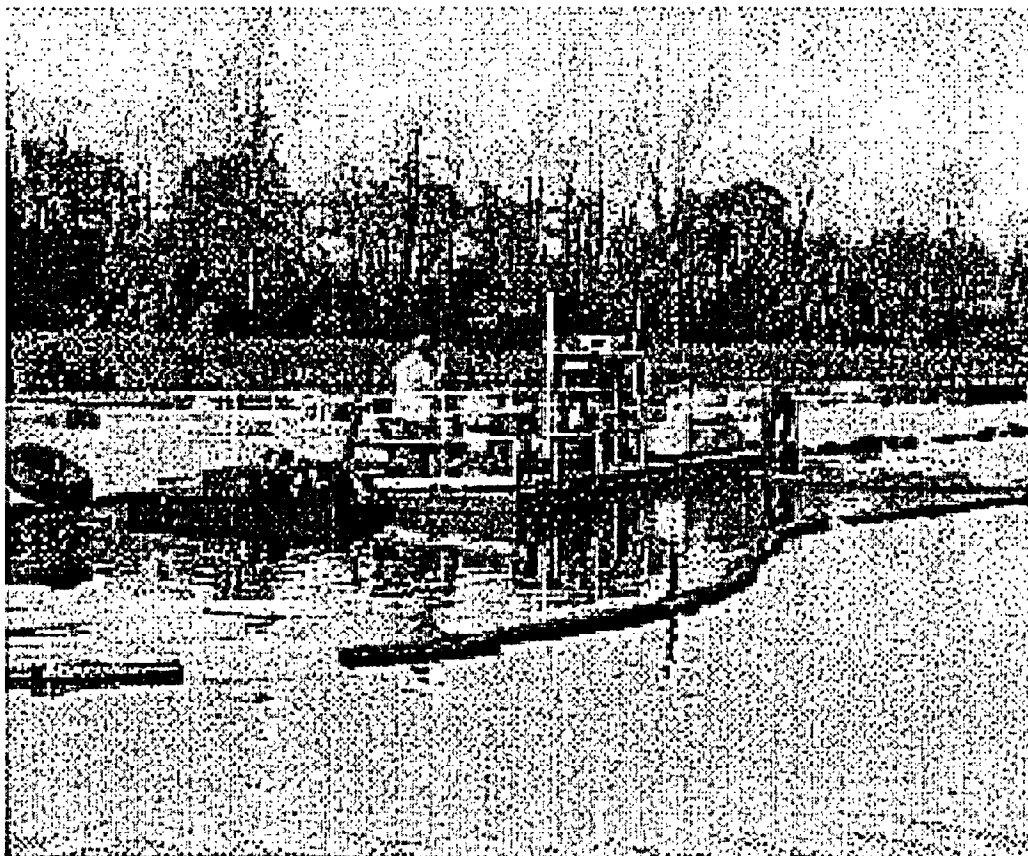

Project: Welland River Sediment Removal Demonstration

Year 91

Location: Welland, Ontario, Canada

Pilot Scale

Client/Funding Agency	Contact	Phone
Remediation Technologies Program/Great Lakes Cleanup Fund Atlas Specialty Steels	Ian Orchard (Environment Canada) Don Marr (Atlas Specialty Steels)	(416) 739-5874 (905) 735-5661

* Monitored * Auditor: Acres International Limited Phone: (905) 374-5200

Removal Rate(m³/hr): 15 Amount Removed In-Situ (m³): 127

Removal Cost(US\$): \$324,000.00

Mobilization (days): 7 Demobilization (days):

Site Conditions: The dredging site was located on the lower reach of the Welland River. The area offshore from the McMaster Avenue municipal sewer outfall which is one of several existing municipal, industrial and residential outfalls on the east bank of the river in the area. The dredge site is generally residential or parkland. Figure 1 shows study area.

The width of the Welland River varies from approximately 40 to 60 m. The maximum depth of water is approximately 4 m. Historical average river flow ranges from approximately 14.2 m³/s in June/July to 24.6 m³/s in March, corresponding to current velocities of 0.15 to 0.26 m/s. Due to downstream flow controls, the river undergoes apparent flow reversals on a daily basis.

Past industrial discharges through the McMaster Avenue and other nearby downstream outfall have resulted in two accumulations of reef-type deposits of oily, black, fine to coarse granular, metallic industrial mill-scale, totalling approximately 5,000 m³ (estimate from 1990). The maximum thickness of the industrial deposits is approximately 2.5 m.

Approximately 25,000 m³ of clay and silt river sediments have also been variably impacted by the contaminated discharges.

The mill-scale and the contaminated sediment contain concentrations of several metals, including copper, chromium, iron, lead, manganese, nickel and zinc, as well as phosphorus and oil and grease which exceed the Ontario Ministry of the Environment & Energy (OMOEE) sediment quality guidelines.

Contaminants Present:	Contaminants	Max. Concentration (ug/g, dry)	LEL (ug/g)	SEL (ug/g)
	Chromium	5,000	26	110
	Copper	860	16	110
	Iron	380,000	20,000	40,000
	Lead	870	31	250
	Manganese	6,900	460	1,100
	Nickel	11,000	16	75
	Zinc	1,300	120	820
	Oil & Grease	45,300	---	---

The LEL and the SEL are both guidelines established by the Ontario Ministry of the Environment & Energy for the protection and management of aquatic sediment quality in Ontario. The LEL represents the lowest concentration where a contaminant will have an effect on benthic organisms, while the SEL is the concentration where contaminants will have a detrimental effect to the majority of benthic organisms. The SEL for PAHs is also dependent on the concentration of total organic carbon.

Water Quality: Results from sampling performed in 1990 indicate that, from the 32 parameters analyzed, only aluminum, copper, total phosphorus and total phenols exceed the Provincial Water Quality Objectives for the Protection of Aquatic Life within the vicinity of the demonstration area. Iron levels were exceeded both upstream and downstream of the study site, but not within. The high aluminum concentration may be due to the suspended clay content of the water, since the Welland River drains in an area of predominantly clay soils.

Turbidity: Dredging in the original mode resulted in an overall average turbidity of 18.5 FTU at the dredge head compared to background turbidity of 5 FTU. Dredging without the shroud and with the standard auger resulted in an overall average turbidity of 17.6 FTU. Operating in a more flexible mode (more freedom to the operator) resulted in longer periods of dredging and less frequent plugging of the pipeline while still maintaining low turbidity levels at the dredge head (average 13.8 FTU). Operating without the screen resulted in the lowest turbidity levels at the dredge head (average 5.4 FTU) but also resulted in frequent blockage of the intake or dredge pump.

Total Suspended Solids: Total suspended solids (TSS) concentrations at a distance of 10 m away from the dredge were well below the Environment Canada criteria of 25 mg/L at a distance of 25 m. The maximum TSS concentration measured at a distance of 10 m away from the dredge from 21 mg/L.

Percent Solids: The overall average percent solids including mill scale and river sediment, in the pumped slurry was low (2.1 %, excluding rinsing) and varied considerably during the demonstration due to the structure of the dredging program (frequent starts, stops and flushing of the pipeline) and the generally cautious approach to the dredging to minimize environmental concerns. The removal of the intake screen increased the overall average percent solids to 3.7% while the removal of the dredge head shroud resulted in the highest overall

average percent solids of 4.4%.

Site Containment Used? No Yes

A commercially available silt curtain was selected for the project and was modified by the manufacturer to meet specific demonstration requirements. It consisted of an impermeable polyester-reinforced vinyl fabric which extended the full depth of the water column. Segmented foam flotation members were fabricated into the full length of the top edge. Additional flotation units were fabricated by Atlas from empty barrels. The flotation units and the curtain were anchored in place by steel cables attached to concrete blocks placed on the river bed.

Exceed Set Standards? The Remediation Technologies Program of Environment Canada has developed a set of standards in order to audit demonstrated innovative sediment removal technologies. The following are those standards :

Sediment Removal Phase :

- 1) Turbidity: Turbidity beyond a distance of 25 m of the actual removal location shall not exceed ambient levels by more than 30%.
- 2) Suspended Solids: Beyond a 25 m distance of the actual removal location, suspended solids shall not exceed ambient levels by more than 25 mg/l.
- 3) Total Organic Carbon: Total Organic Carbon (TOC) content should be within the range of 0.4-27 mg/l in surface water beyond 25 m of the removal operation. TOC shall not exceed background levels by more than 30% when background concentrations are greater than 27 mg/l.
- 4) No Overflow or Leaks: A minimum freeboard of 1 m must be maintained in the hopper of holding facility for the excavated sediment. The holding facility must be sealed for transport to the pre-treatment/disposal site.
- 5) Removal Efficiency: The solids to liquids ratio in the excavated material should be at least 30% by volume.
- 6) Effluent Quality: Maximization of solids removal is paramount. Solids suspended in the slurry mixture must be removed by some means, either mechanical or chemical (flocculation). If the extracted material is fine grained, provision should be made to treat the effluent.
- 7) Production Rate: The production rate of the sediment removal equipment should be adjusted to show sufficient settling time for effluent to meet the Provincial Water Quality Objectives (PWQOs). Therefore, the feed rate of the excavated material into the holding facility for transport to the pre-treatment disposal area should be adjusted accordingly.

Transport Phase:

- 1) No Overflow or Leaks: No overflow or leaks of excavated material shall be allowed during transport to the disposal or pre-treatment area. Use of pipelines or other fully closed transport mediums is encouraged.
- 2) Transport Rate: The rate of material being transported must be adjusted to meet the handling capacity of the pre-treatment or disposal facility.
- 3) Contact: No contact is permissible between the contaminated sediment and human, bird and aquatic life.

Pre-Treatment Phase :

- 1) Effluent Quality: Effluent quality of the supernatant water and effluent from the pre-treatment process should meet applicable federal and provincial standards and guidelines.
- 2) Waste Handling: All wastes from the pre-treatment process should be handled and disposed of in accordance with appropriate regulatory requirements.

In addition to Environment Canada's standards for the evaluation of the dredge, the OMOEE and the OMNR had requirements in order to protect the aquatic life. The OMNR standard was based on a limit of 10 % or 25 mg/L increase from ambient level of the total suspended solids concentration downstream of the silt curtain. The OMOEE guideline was based on an increased of turbidity levels of 80 FTU from ambient levels 100 m downstream of the silt curtain.

Those standards were not exceeded during the demonstration.

Description: In order to assess the project and the dredge performance, an instrumentation/data logging package was added to the dredge. Analog displays provided the dredge operator with real-time indicators of dredging performance. The instrumentation included :

- 1) one nucleonic densitometer
- 2) one electromagnetic flowmeter
- 3) one dredge head vibration sensor
- 4) one dredge head turbidity sensor
- 5) analog displays for above-noted sensors
- 6) one datalogger with 4 input channels

Removal Rate :

The Mud Cat 915 ENV was demonstrated in the shallow waters of Welland River. This technology was manufactured by Ellicott Machine Corporation of Baltimore, Maryland, United States, and owned and operated by Auburn Contractors Incorporated of Burlington, Ontario, Canada.

The dual convergence of the horizontal auger head, with an enclosed housing for the auger were the principal components to minimizing sediment resuspension. Other components to the operation included hydraulic vibrators to supplement the excavation, and removable front screens to restrict oversized material from obstructing the system.

Dredging started in the "original" (no modifications) mode and during the mode of the demonstration, numerous planned modifications were made to the dredge and the operating procedures to allow evaluation of the dredge in terms of slurry production yields and turbidity. These modifications included: 1) removal of the shroud screen to reduce ploughing of the sediment in front of the dredge head, 2) welding small steel bars across the suction intake to minimize the entry of debris, 3) installation of a check valve in the pipeline at the dredge discharge to minimize backflow, and 3) relocation of the shroud vibrators in an effort to impart a more horizontal action to the head.

Midway through the demonstration, the modified auger was replaced with the standard toothed auger and near the end of the demonstration, the auger shroud was removed.

The removal rate was not calculated at the time. Projected production rates for full-scale remediation were estimated at 10 to 20 m³/hr.

Amount Removed in-situ (m³):

The data have indicated that 127 m³ of in-situ material has been removed during the demonstration. From this total volume, 64% was mill-scale while 36% was non-mill-scale type sediment.

Removal Cost:

The total cost of this demonstration was 324,000 \$(US), leading to a unit cost of 2,551 \$(US)/m³. This high cost was related to special demonstration requirements and to health & safety requirements related to dredging in highly contaminated sediment.

Mobilization Time (days): 7

The portable Mud-Cat MC-915 ENV suction dredge, manufactured by Ellicott Machine Corporation of Baltimore, Maryland was selected as the preferred dredging technology for the demonstration. The following modifications were incorporated into the dredge:

- 1) Auger: hydraulic forward tilt and manual transverse tilt and dual convergence variable pitch and multi-flight auger,
- 2) Removable vibrating front shroud,
- 3) Special truss boom assembly including suction hose, modified to allow pivoting for 15 ft digging depth.

A 20 cm pipeline consisting of flexible floating section and a rigid land based section was installed over a distance of 1,500 m from the dredge to the treatment facility. A booster pump was necessary as the combination of head and friction loss in the approximately 1,500 m length of pipe was too large (240 ft) for the centrifugal pump on the dredge to handle alone. The booster pump was located approximately 700 m downstream from the dredge. A silt curtain was also placed in order to confine the work area.

Demobilization Time (days): not available

Regulatory Approvals:

As part of the project, several approvals and permits are required from various departments of the federal & provincial governments and property owners affected by the project.

Federal Government:

Canadian Coast Guard, Department of Transport

- a) Approval to "Dredge in a Navigable Waterway under Section 5(2) of the Navigable Waters Protection Act (NWPA), RSC 1985, Chapter N-22".

Department of Fisheries and Oceans (DFO)

- a) Approval under Section 33 of the Fisheries Act.

Federal Environmental Assessment and Review Office

- a) Initial Screening of the proposal undertaking in keeping with the requirements of EARP.

Provincial Approval:

- Ministry of Natural Resources (MNR)
 - Public Lands Act
 - Lakes & River improvements Act
 - Fisheries Act
- Ministry of the Environment and Energy
- Environmental Protection Act

Affected Property Owners

- City of Welland
- Several land owners

An Environmental Screening Document (ESD) has been prepared and sent to the Project Planning Committee and members of the public for their review and comments.

The removal and transport technology and procedures was explained and presentation of the project by the RAP team, the Remediation Technologies Program and the Atlas Specialty Steels, Acres International was performed during an open

house in Welland that took place prior to the demonstration. The public was invited to attend, ask questions and raise any concerns they had. The questions and answers were provided in the final ESD as an attached Addendum.

During the open house, copies of the ESD were made available to the public. A final version of the ESD was sent to the reviewing committee and those members of the public who requested a copy during the open house.

Bibliography:

Miles, P. & D. Marr. 1994. The Welland River Dredging Demonstration. Proceedings of the Second International Conference on Dredging and Dredged Material Placement. Dredging '94. Orlando, Florida, USA. Volume 2. p.1061-1070. November.

Pelletier, J-P. 1993. Cinq sites d'extraction de sédiments contaminés utilisant des techniques innovatrices. Villes portuaires, acteurs de l'environnement. Quatrième conférence internationale Villes et Ports. Montréal, Québec, Canada. p.175-p185. October.

Eriksson Sediment Systems Inc., Method for Marine Sediment Removal, Dewatering..

21-Jan-98

TechID: 310

Technology Type:

Freezing.

1. Encapsulation of sediment in solid frozen block
2. Dewatering of frozen sediment.
3. Pore water purification.

System Works With: Strong Currents, Water Depth 2-10m, Limited Shore Access

Development Stage: Pilot Scale

Country Of Origin: Canada

Description:

Process Description:

The Eriksson System of sediment removal significantly reduces the amount of sediment redistribution and water column contamination normally associated with conventional sediment removal methods. This proprietary system involves freezing contaminated sediment into blocks within containment cells which can then be easily removed with minimal contaminant disturbance. A significant advantage of the process is that only water naturally occurring in the sediment block is removed. This minimizes costly dewatering and water treatment, greatly improving process economics. The Eriksson System requires only a single-pass during removal and thus reduces the potential of sediment resuspension from subsequent passes in an area of fine sediment.

Process Operation:

With the use of a placement tower, rows of containment cells are organized in a grid-like pattern in a sediment guided by visual or electronic navigation equipment. Cells can be arranged so that only targeted sediments are removed. Each cell is typically two meters square and can penetrate the sediment to a depth of up to two meters. A cluster of tines protrudes downward from the underside of the cell mainframe into the sediment. As refrigerant is circulated through the tines, heat is extracted from the surrounding sediment. After a period of approximately 24 hours, the entire sediment block is sufficiently frozen for removal. Cells are removed only after the placement of adjacent cells in order to minimize sediment redistribution and drift into the already cleaned area. Oversized debris is detected by sounding equipment and can be removed by customized freezing cells adapted to suit the size and shape of the debris. Once cells are retrieved, the sediment is dewatered and ready for further treatment. Removal rates are determined by site conditions and the number of cells in use.

Limitations: Large debris (this can be handled conventionally).

Type of Power: Electric (municipal or generator).

Government Funding: Great Lakes Cleanup Fund, DESRT, SITE, Superfund, ETP

Environmental Concerns:

Health & Safety Plan Available:

Regulatory Approvals

Setup/Feed: Mobilization (days):
Removal Rate Average (m³/hr): 40

Demobilization (days):

Cost: Capital Cost (US\$):
Unit Cost (US\$/m³): \$175.00 – \$250.00 Average Cost (US\$/m³): \$200.00

Capital cost : Varies with site. Operating cost: \$175.00 to \$250.00. Cost comments: Multi-phased system from removal through pre-treatment INCLUSIVE, any sediment.

Developers:

Eriksson Sediment Systems Inc.
50 Walton St.
Port Hope, Ontario
Canada L1A1N1
Notes

Contact: Carr, Roger N.
Phone: (905) 885-6664 Ext:
Fax: (905) 885-7471
Email:

Vendors:

Eriksson Sediment Systems Inc.
50 Walton St.
Port Hope, Ontario
Canada L1A1N1
Notes

Contact: Carr, Roger N.
Phone: (905) 885-6664 Ext:
Fax: (905) 885-7471
Email:

Literature References:

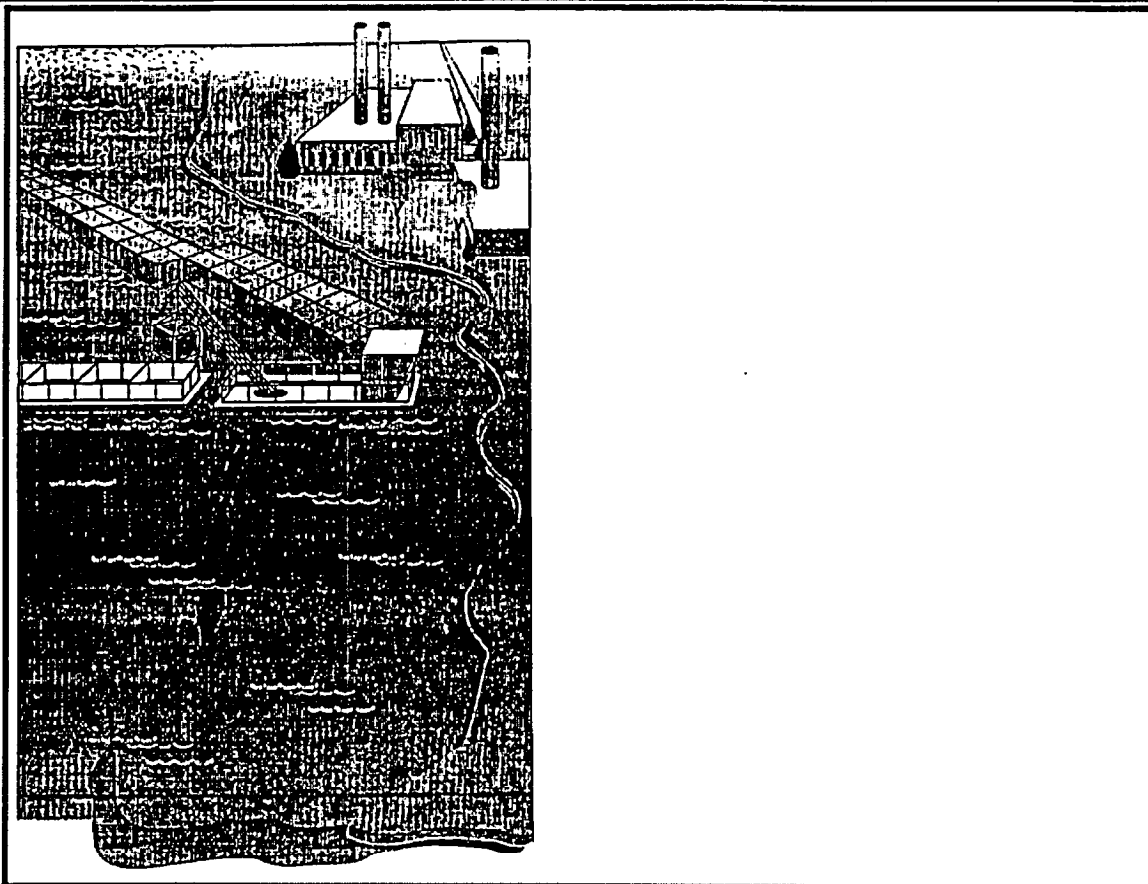

Project: Wheatley Harbour

Location: Lake Erie, Ontario, Canada

Year 95
Pilot Scale

Client/Funding Agency	Contact	Phone
GLCF/OCETA		

Not Monitored

Removal Rate(m³/hr): Amount Removed In-Situ (m³):

Removal Cost(US\$):

Mobilization (days): Demobilization (days):

Site Conditions:

Contaminants Present: Nutrients.

Water Quality:

Turbidity:

Total Suspended Solids:

Percent Solids: Retrieve pore water only (usually 50%).

Site Containment Used? No Yes

Exceed Set Standards?

Description: Details still being developed with respect to demonstrations. Full reports and analysis will be available upon completion.
(Project to continue in March 1996).

HAM, Visor Grab

06-Jan-98

TechID: 352

Technology Type: Mechanical

System Works With: Debris, Strong Currents, Water Depth 2-10m, Limited Shore Access, Water Depth < 2m, Water Depth > 10m

Development Stage: Commercial

Country Of Origin: The Netherlands

Description:

Removing silt from contaminated sea, river and lake beds calls for accuracy, and the minimum possible degree of silt disturbance. It is also important that the silt be removed at a high density. The environment-friendly visor dredging grab, designed by HAM, Hollandsche Aanneming Maatschappij bv, ensures that a minimum of water enters the sediment. The total quantity of sediment to be removed is therefore also kept to a minimum. This results in considerable cost savings.

Operation: Basically, the shape of the grab is that of a dredging grab, within which there is a revolving visor flap, closed by means of two hydraulic cylinders. The environment-friendly grab is handled in the usual way by a mechanical excavator. When the grab has been filled, the visor is closed before the grab is raised to empty the contents into a transport barge. Closing the grab in this way avoids the bed material becoming compressed, which can make emptying the grab difficult. A rubber strip along the edge of the visor ensures a watertight closure.

Limitations:

Type of Power: Diesel

Government Funding: Great Lakes Cleanup Fund, GASReP

Environmental Concerns:

Health & Safety Plan Available:

Regulatory Approvals

Setup/Feed: Mobilization (days):

Demobilization (days):

Removal Rate Average (m³/hr): 50

Cost: Capital Cost (US\$):

Unit Cost (US\$/m³): -

Average Cost (US\$/m³): \$77.00

Developers:

Hollandsche Aanneming Maatschappij bv

227 Pumphill Rise SW

Calgary, Alberta

Canada

T2V 4C8

Notes

Contact: van der Wal, J.U.

Phone: (403) 253-1702

Ext:

Fax: (403) 253-1703

Email:

Vendors:

Wayne Jones Construction

R.R. #1

Midland, ON

Canada

L4R4K3

Notes

Contact: Jones, Wayne

Phone: (705) 526-4461

Ext:

Fax: (705) 526-4461

Email:

Literature References:

HAM, Visor Grab

06-Jan-98



Project: Penetanguishene Harbour Wood Pile Removal Demonstration

Year 94

Location: Penetanguishene, Ontario, Canada

Full Scale Demo

Client/Funding Agency	Contact	Phone
Remediation Technologies Program/Great Lakes 2000 Cleanup Fund Severn Sound Remedial Action Plan Town of Penetanguishene	Ian Orchard	(416) 739-5874

* Monitored * Auditor: Ian Orchard (Environment Canada) Phone: (416) 739-5874

Removal Rate(m³/hr): 30 Amount Removed In-Situ (m³): 375

Removal Cost(US\$): \$28,800.00

Mobilization (days): 3 Demobilization (days): 2

Site Conditions: During the 1800's and until the 1960's, sawmills and logging companies flourished in Penetanguishene. Transport of logs in addition to sawmill activity contributed to the degradation of Penetanguishene's waterfront. Dumping of wood waste in the harbour has put increasing pressure on fish and wildlife habitat. On November 1992, a rare water level fluctuation exposed several hectares of wood wastes covering the harbour bottom were unveiled. This wood waste prevents plants from growing, and therefore fish from using the area.

General

Two self-recording current instruments were operated from June to December 1985. The recorded values indicated that the net flow from Penetang Bay to Severn Sound ranged between 0.4 and 3.8% volume of Penetang Bay (16.7 X106 m³/d) during September to December. However, the net flow during June and July was between 6.5 and 2.9% from Severn Sound to Penetanguishene Harbour.

Currents in the project area are expected to be low (<2 cm/sec) with local wind and wave action causing the only transport of solids.

During a manual sounding survey performed in May, 1994, the water depth in the study area ranged from 0 m (at the shoreline) to 2.2 m (at the most offshore point where wood debris has been found). Important water level changes have occurred in the past years. From earlier studies, it has been estimated that the water depth during the removal project could range from anywhere between 0 (at shore) and 4.5 m at the most offshore point.

Contaminants Present: During the demonstration project, only some small quantities of the original clay underlying the wood pile was removed. Chemical analyses of the clay indicated that no other contamination than background levels of contaminants would be uncovered. The wood pile was an impairment to fish habitat.

Water Quality: The main concern related to water quality in Penetang Bay and the entire Severn Sound is nutrient loadings. Very few contaminants have been found to exceed either provincial and federal guidelines.

Several studies have indicated that the phosphorus levels near the study area have decreased by 50% since 1969. This decrease is presumed to be due to improved operating efficiency at the Penetang Water Pollution Control Plant (WPCP) and to detergent phosphorus control. Results from one water quality station located near the study area have indicated that the mean total nitrogen concentrations were one of the highest throughout Severn Sound. In recent years, Total Inorganic Nitrogen (TIN) have been higher suggesting less demand for nitrogen by the algal and plant communities. That station had the most important shift from organic to inorganic forms of nitrogen. This is probably due to partial nitrogen removal at the WPCP and to an increase in nitrate occurring throughout the Great Lakes.

Copper, mercury, aluminum and iron exceeded the Provincial Water Quality Objectives (PWQO) in Penetanguishene Harbour, outside the study area. All organic contaminants concentrations were below the detection levels. No results are available for the immediate study area.

Turbidity: The water quality was monitored throughout the project. Since very little contamination was found in both the water and the sediment, it was decided that water sampling would be performed once a week only. The sampling program focussed mainly on the quantity of re-suspended material that could enter the bay from the confined area.

Seven sampling stations were used during this program. Station 1 was located at mid-bay, and serve as the ambient level indicator. Stations 2, 3 & 4 were located 10 m outside the silt curtain, while stations 5, 6 & 7 were located inside the confined area.

Samples were collected at mid-depth and were analyzed for the following parameters : chloride, calcium, magnesium, sodium, potassium, hardness, conductivity, pH, turbidity, ammonia, nitrite, nitrate, phosphate, suspended solids, total phosphorus, total Kjeldahl nitrogen, dissolved organic carbon, dissolved inorganic carbon and reactive silicate.

Figure 2 was produced using the turbidity results. These results indicate that turbidity gradually increased in the confined area, which is related to the nature and the particle sizes of the dredged material. Sawdust and fine particles such as clay tend to remain in suspension longer than large particles such as sand and gravel. An

HAM, Visor Grab

06-Jan-98

accumulation of easily re-suspended material occurred in the confined area throughout the duration of the project. These results also indicate that this re-suspended material took approximately one week to settle.

Results from Figure 2 also indicate that very little material left the confined area since the turbidity immediately outside the silt curtain was comparable to the turbidity at mid-bay (ambient level).

Total Suspended Solids: The total suspended solids concentrations results indicated the same trend as for those for turbidity.

Percent Solids: During the larger wood waste removal portion of the project, the percentage of solids was estimated to be very close to 90% since excess water was not added through the use of grapple forks.

During the Visor grab demonstration, the percentage of solids has been visually estimated to be around 45 %, with some excess water being added to each grab.

Site Containment Used? No Yes

A silt curtain was deployed to cover the entire working area. Wooden poles were hammered in place in order to minimize movement of the silt curtain. Heavy chains were secured at the bottom of the curtain to ensure anchorage to the bottom of the bay, while styrofoam buoy were placed at the top portion of the curtain to act as a floatation measure. The curtain was secured on shore at both ends.

Exceed Set Standards? The following standards were adapted from the Remediation Technologies Program's :

REMOVAL**Turbidity and Suspended Solids**

Since very little contamination has been detected in the bottom material, turbidity will not be strictly controlled inside the confined area, but will be outside. Turbidity and total suspended solids measurements will be performed inside the confined area in order to audit the removal technology. All provisions should be taken to ensure that the turbidity level is not increased outside the silt curtained area.

No Overflow or Leaks

A minimum freeboard of half (½) a metre must be maintained in the holding facility for the excavated material.

Removal Efficiency

The solids to liquids ratio in the excavated material should be at least 30% by volume.

Production Rate

The production rate of the sediment removal equipment should be at least 40 m³/hr; the daily production should be close to 400 m³.

TRANSPORT**No Overflow or Leaks**

No overflow or leaks of excavated material shall be allowed during transport to the storage area.

Transport Rate

The rate of material being transported must be adjusted to meet the handling capacity of the off-loading methodology.

Description: In early 1994, partnership was established between the Town of Penetanguishene, the Severn Sound Remedial Action Plan and Environment Canada's Great Lakes Cleanup Fund through the Remediation Technologies Program in order to provide funding and expertise to help restore the valuable fish and wildlife habitat of a section of Penetanguishene Harbour. Without this partnership, the project could have never taken place.

Removal Rate :

This project had two components. First, the removal of over 4,000 m³ of wood wastes using conventional technologies and methodologies. The second objective was to demonstrate an innovative sediment removal technology in order to assess its appropriateness to remove contaminated sediment in other Areas of Concern throughout the Great Lakes basin.

Figure 1 indicates that the daily maximum production rate achieved using the crane equipped with the grapple fork was 60 m³/hr, with an average of approximately 30 m³/hr. The lowest daily production rates were caused by a statutory holiday (Thanksgiving, 10 October 1994), downtime, use of dragline (17 October 1994) and no removal days (22 October 1994, and from 25 to 29 October 1994). A total of 139.25 hours were required to remove 3,970 m³ of wood wastes, of which 120.5 were devoted to the removal of 3,595 m³ of larger wood wastes and 19 hours were devoted to the Visor Grab demonstration. This total duration leads to a dredging efficiency of over 90 %, with an average production rate during the removal of larger wood wastes of approximately 30 m³/hr. Cycle times fluctuated between 55 seconds to 1 minutes and 30 seconds during removal of larger debris using the grapple fork. From the 19 hours during which the Visor Grab was demonstrated, approximately 5 hours were devoted to transport of off-loading of material. Therefore, the total duration of the removal period was 14 hours, which leads to an average production rate of approximately 27 m³/hr. The average cycle time was approximately 55 seconds, with a percentage of solids averaging approximately 40 % (visual estimate). It should be noted that performances related to the Visor Grab are related mostly to the excavator, the operator and the water depth. The above-noted performances could be totally different under other site specific conditions.

Amount Removed in-situ (m³) :

The maximum volume of wood removed in one day was 630 m³, while the minimum was 0 m³. The daily average was approximately 300 m³. Zero cubic metre volume removed was due to statutory holiday (Thanksgiving, Monday, 10, October 1994), use of dragline (Monday, 17 October 1994) and the fact that no removal work was performed on that day (Saturday, 22 October 1994, Tuesday, 25 October 1994 to Friday, 28 October 1994). A total of 139.25 hours were

HAM, Visor Grab

06-Jan-98

required to remove 3,970 m³ of wood wastes, of which 120.5 were devoted to the removal of 3,595 m³ of larger wood wastes using the grapple fork and 19 hours were devoted to the Visor Grab demonstration during which 375 m³ were removed.

Removal Cost :

The cost related to the first phase of the wood pile removal demonstration (larger debris removal) was 81,720 \$(US) (unit cost 22.73 \$(US)/m³). The total cost for removal only was 60,120 \$(US) (unit cost 16.72 \$(US)/m³). The cost for the demonstration of the Visor grab was 28,800 \$(US) (unit cost 76.80 \$(US)/m³).

Mobilization Time (days) : 3 days

Mobilization of the equipment started on Friday, 30 September 1994 and ended on Monday, 03 October 1994. The equipment brought by the contractor for the project was mainly composed of :

- One Caterpillar 235 backhoe
- One crane
- Two grapple forks, one dragline bucket and one clamshell bucket
- One transport barge with spuds
- Two containment barges (one with spuds)
- Two tugboats
- Two tandem trucks
- One Visor Grab, and
- One 200 m X 2 m silt curtain.

In addition to the above-noted equipment, the Town of Penetanguishene provided dump trucks, a front-end loader, storage site, site coordination, on-land siltation control and security equipment.

Using logs and rocks, an off-loading platform was created to facilitate the discharge of the loading barges. Sitting on the platform, the backhoe was used to off-load the barges into dump trucks.

Town of Penetanguishene Public Works' Department prepared the storage area. Snow fences were placed around the storage area as a safety measure in order to minimize public exposure to heavy machinery (trucks, bulldozer, backhoe, etc) movement. Hay bails were also placed on the bay side of the storage area in order to capture most of the suspended matter in the excess water brought to the storage site that could re-enter the bay.

Demobilization Time (days) : 2 days

On Wednesday, 06 October 1994, most of the equipment was demobilized from the site. The silt curtain had to be left in place until 14 October 1994 in order to allow the turbidity to decrease to ambient levels.

Regulatory Approvals :

In order to carry out the remediation project, the Federal Environmental Assessment and Review Process (EARP) was initiated due to the facts that federal funding was provided for this project and that Penetanguishene Bay is a federal harbour. Federal Fisheries Act also applied to this project due to the same above-noted reasons. Provincial approvals were also required since all the removed wood wastes would be placed on Town of Penetanguishene's land.

Information on the site and the project (site history, existing environmental conditions, public involvement, expected effects of the project and the appropriate mitigation measures, description of the project, etc.) was compiled and an Environmental Screening Document was produced to fulfill the requirements of EARP. This document was forwarded to the Federal Environmental Assessment Coordinating Committee (EACC) for federal review. This document was also used as a tool to obtain approvals from the Canadian Coast Guard, the Department of Fisheries and Oceans, and the Ontario Ministries of Environment & Energy and Natural Resources. A letter of concurrence was also requested to the only affected property owner : the Town of Penetanguishene. The following is a listing of approval requirements for the project :

Federal Government

Canadian Coast Guard, Department of Transport:

- a) Approval to "Dredge in a Navigable Waterway under Section 5(2) of the Navigable Waters Protection Act (NWPA), RSC 1985, Chapter N-22".

Department of Fisheries and Oceans (DFO):

- a) Approval under Section 33 of the Fisheries Act.

Federal Environmental Assessment and Review Office:

- a) Initial Screening of the proposal undertaken in keeping with the requirements of EARP.

Provincial Approvals:

Ministry of Natural Resources (MNR)

Public Lands Act (not required for removal operations)

Lakes & River improvements Act (not required since the water is federal)

Ministry of the Environment and Energy

Environmental Protection Act

Affected Property Owner:

Town of Penetanguishene

HAM, Visor Grab

06-Jan-98

Public consultation has been an on-going process in the municipality of Penetanguishene for many years. Once a month, the public and the press is invited to a Council members' open session when projects are presented to the public for discussion. Since the Town has approached the Severn Sound RAP for remediation options, the public has been actively involved in the decision process. An open workshop was held in Penetanguishene on March 29, 1994 when the removal project was first presented to the those member of the public in the attendance. Only positive responses were received.

The Severn Sound RAP's public involvement process includes media releases, displays and presentations at special events, and a monthly meeting of the Public Advisory Committee (PAC) which is announced in the local news media as open to the public. The PAC has been kept informed on the planning process with regard to this project, and PAC members' participation has included collaboration on the design of the on-shore restoration and on the debris handling and recycling aspects of the project.

The removal and transport technology and procedures was explained and proposed during an open house in Penetanguishene on September 13, 1994. Presenters included the RAP team, the Remediation Technologies Program and the Town of Penetanguishene. The public was invited to attend, ask questions, raise any concerns they had and review the ESD. The questions and answers were provided in the final ESD. Members of Penetanguishene's Waterfront Development sub-committee, Council Members, the Severn Sound Remedial Action Plan Technical Committee and Public Advisory Committee and the Remediation Technologies Program were also in attendance.

A review period of 15 days was allowed to the public to respond to the project presented during the open. Very strong support for the wood removal project was received from the community during and after this open house.

Monitoring :

Water quality was monitored by the Remediation Technologies Program of Environment Canada.

Bibliography:

Pelletier, J-P, C. Dimock. 1994. Penetanguishene Harbour Wood Pile Removal Demonstration and Habitat Re-Habilitation Projects - Environmental Screening Document. Produced for the Town of Penetanguishene. September.

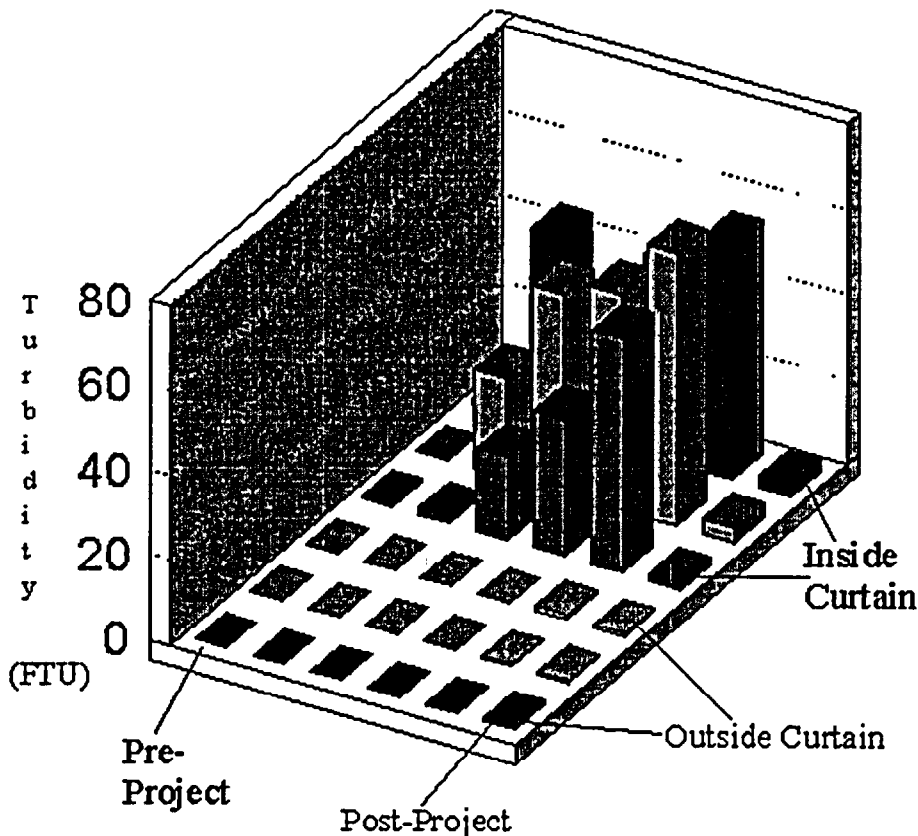

Penetanguishene Wood Removal Project
Daily Production Rate

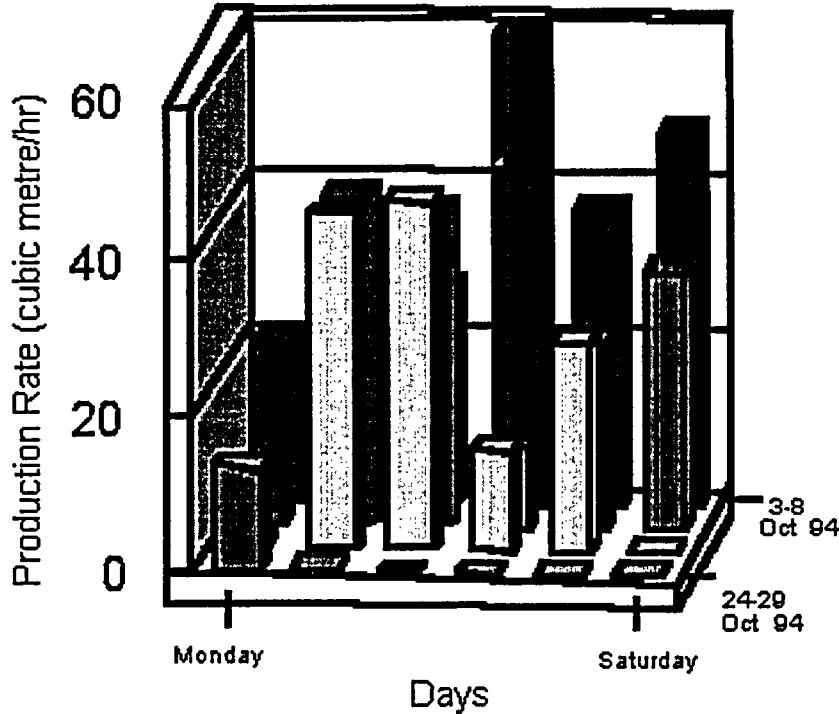

Project: Bay Port Marina

Year 92

Location: Midland Bay, ON, Canada

Client/Funding Agency	Contact	Phone

Not Monitored

Removal Rate(m³/hr): Amount Removed In-Situ (m³):

Removal Cost(US\$):

Mobilization (days): Demobilization (days):

Site Conditions:

Contaminants Present:

Water Quality:

Turbidity:

Total Suspended Solids:

Percent Solids:

Site Containment Used? No Yes

Exceed Set Standards?

Description: Silt curtain and floating boom were installed to control sediment and floating debris in Midland Bay at Bay Port Marina. The curtain was approximately 450 m long and 9 m deep, controlled with floats and weights. Also, large quantities of logs (piles) were removed from the bay and delivered to Elmira to be resawed into lumber.

Project: Wayne Jones/Matchadash Bay

Year 91

Location: Matchadash Bay, ON, Canada

Full Scale Demo

Client/Funding Agency	Contact	Phone

Not Monitored

Removal Rate(m³/hr): Amount Removed In-Situ (m³):

HAM, Visor Grab

06-Jan-98

Removal Cost(US\$):
 Mobilization (days): Demobilization (days):
 Site Conditions:
 Contaminants Present:
 Water Quality:
 Turbidity:
 Total Suspended Solids:
 Percent Solids:
 Site Containment Used? No Yes
 Exceed Set Standards?

Description: Dredged out channel approximately 10 m wide and 350 m long. The materials removed were 50% wood waste from old Saw Mills, mixed with silt from Goldwater River. Materials were loaded on trucks with excavator and trucked to disposal yard.

Project: Wayne Jones/Victoria Harbour

Year 90

Location: Victoria Harbour, ON, Canada

Full Scale Demo

Client/Funding Agency	Contact	Phone

Not Monitored

Removal Rate(m³/hr): Amount Removed In-Situ (m³): 15000
 Removal Cost(US\$):
 Mobilization (days): Demobilization (days):
 Site Conditions:
 Contaminants Present:
 Water Quality:
 Turbidity:
 Total Suspended Solids:
 Percent Solids:
 Site Containment Used? No Yes
 Exceed Set Standards?

Description: Project at site of old Mill Yards (from early 1900's). Material removed from bay was approximately 25% wood in slab form, logs and sawdust. All material was picked out of water with excavator, loaded on tandem trucks on our barge, then run off at landing and trucks then driven to dump site.

Project: Wayne Jones/ Wye Heritage Marina Project

Year

Location: Wye Heritage Marina, ON, Canada

Client/Funding Agency	Contact	Phone

Not Monitored

Removal Rate(m³/hr): Amount Removed In-Situ (m³):
 Removal Cost(US\$):
 Mobilization (days): Demobilization (days):
 Site Conditions:
 Contaminants Present:
 Water Quality:
 Turbidity:
 Total Suspended Solids:
 Percent Solids:
 Site Containment Used? No Yes
 Exceed Set Standards?

Description: Showed method used for dredging and loading material onto trucks and moving to landing, driving off barge, dumping and repeat.

Harbour Development, Dredges

06-Jan-98

TechID: 353

Technology Type: Hydraulic, Mechanical

System Works With: Water Depth 2-10m, Water Depth > 10m

Development Stage: Commercial

Country Of Origin: Canada

Harbour Development, Dredges

06-Jan-98

Description:

We have used our 0.3 m cutter suction dredge to pump environmentally sensitive material ashore to containments. As well, we have pumped material directly out of scows and disposed of ashore.

DREDGES:

1) Irving Willow:

Propulsion - Twin Screw Fixed; HP 1400 (700 each engine); Towing Winch - Swann Wooster Single Drum; Navigational - Radar, SSB Radio, VHF Radio, Loran C Navigator

2) Irving Hemlock:

Propulsion - Twin Screw Fixed; HP 1700 (850 each engine); Towing Winch - Markey Single Drum; Navigational - Radar, SSB Radio, VHF Radio, Loran C Navigator

3) Cranemaster:

Gross tonnage 1236; Built 1969

Equipment: 2- 30 m long 1.2 m x 1.2 m 'Breast Spuds

1- 30 m long 1.2 m x 1.2 m 'Walking Spud

Deck Winches: 1- Skagit RG-90 Two Drum Waterfall Linepull - 100,000 # (single line)

1- Clyde 150 Two Drum Waterfall Linepull - 150,000 # (single line)

Dimension: Length: 60 m; Width: 20 m; Depth: 4 m / Cookhouse and bunk trailers for 14 men

Crane: Lima 2400 B 200 ton capacity

6,7,8 or 11 meter clamshell

30 m crane boom

20 m boom extension

JIB available

Welding machine on board

Air supply on board

4) Shovelmaster:

Gross Tonnage: 592 ; Built 1980

Equipment: 2 - 30 m long 1m x 1m 'Breast Spuds

1 - 30 m long 1m x 1m 'Walking Spud

Deck Winches: 2 - 3 Drum Timberland 15,000 # linepull

Dimensions: Length: 50 m; Width: 15 m; Depth: 3.5 m / Cookhouse and bunk trailers for 14 men.

Crane: Lima 2400 b 200 tonne capacity

6, 7, 11 m clamshell

Tub mounted with a frame

23 m shovel boom

Welding machine on board

Air supply on board

5) Depthmaster:

Portable Ammco 35 cm Cutter Suction Dredge; 750 HP on Pump, 14 x 14 Pettibone; 22 m Ladder, in 3 sections, 3 m wide; 35 cm

Discharge; 150 HP Cutter; Draft: 1 m; Spud Height: 18 m

6) Spud Scow Hamilton 56

Length: 42 m Width: 12 m Depth: 3.8 m

Equipped With: 2 - 30 m Spuds; Accommodations for 12 men; Galley; 60 KW Diesel Generator; 20 KW Diesel

Generator; 4 Drum Deck

Winch

DUMPSCOWS:

4 - 1000 m³ Dumpscows: HD-4, HD-5, HD-6, HD-7

Reg. Length: 50 m Gross tonnage: 705

2- 500 m³ Dumpscows: HD-2, HD-3

Reg. Length: 41 m Gross tonnage: 323

DRILLS:

2 - 15 cm IR Down Hole Marine Drills With Casing towers and Carriages

Two G-140 Skagit Two Drum Waterfall, Equal Drums -

Harbour Development, Dredges

06-Jan-98

6-71 GM Diesel Engine with twin disc co type 3 stage torque converter and Skagit TRA-76 reversing drive providing dynamic lowering. Side lever air controls. Ratchets and dogs. Gypsies. Alloy cast iron detachable brake rights with 15 cm wide brakes.

Limitations:

Type of Power:

Government Funding:

Environmental Concerns:

Health & Safety Plan Available:

Regulatory Approvals

Setup/Feed:	Mobilization (days):	Demobilization (days):
	Removal Rate Average (m³/hr):	
Cost:	Capital Cost (US\$):	
	Unit Cost (US\$/m³):	Average Cost (US\$/m³):
	\$0.00 --	

Developers:

Harbour Development
P.O.B. 497
Dartmouth, NS
Canada B2Y3Y8
Notes

Contact: DeWolfe, W.L.
Phone: (902) 494-5767 Ext:
Fax: (902) 466-2483
Email:

Vendors:

Harbour Development
P.O.B. 497
Dartmouth, NS
Canada B2Y3Y8
Notes

Contact: DeWolfe, W.L.
Phone: (902) 494-5767 Ext:
Fax: (902) 466-2483
Email:

Literature References:

Harbour Development, Dredges

06-Jan-98

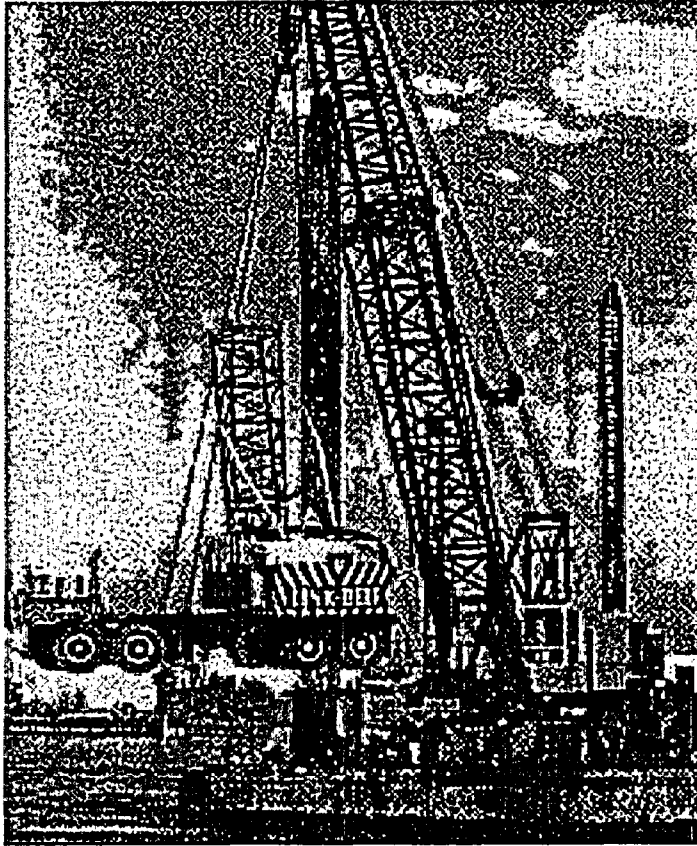

Honma Corporation, No. 1 Water Refresher (High Density Dredging System)

06-Jan-98

TechID: 252

Technology Type: Hydraulic

System Works With:

Development Stage: Commercial

Country Of Origin: Japan

Description:

The No. 1 Water Refresher is a high-density, long-distance, pressure-feeding dredger equipped with an airtight grab bucket. It has the following features:

- The airtight grab bucket reduces the spread of turbidity during dredging, enabling the dredging of high-density sludge.
- The high-pressure feed pump used in this system enables pressurized long-distance feeding of approximately 10 km.
- The system is easily assembled and is portable for operation in various areas such as oceans, lakes and ponds.

Limitations:

Type of Power:

Government Funding:

Environmental Concerns:

Health & Safety Plan Available:

Regulatory Approvals

Setup/Feed: Mobilization (days):

Demobilization (days):

Removal Rate Average (m³/hr): 60

Cost: Capital Cost (US\$):

Unit Cost (US\$/m³):

-

Average Cost (US\$/m³): \$25.00

This is for dredging expenses and transport of slurry a distance of approximately 2 km.

Developers:

Honma Corporation
Engineering Division
Niigata City, 951,
Japan
Notes

Contact: Corporate Civil Engineering Dept.,
Phone: 81252298440 Ext:
Fax: 81252294726
Email:

Literature References:

Author: Honma Corporation (In Japanese)

Title: On a (Water Refresher) for a pressurized long distance sludge-feeding system for high-density dredging

Journal: Agricultural Civil Engineering Society pp. 148-149

Date: Oct 1992

Author: Honma Corporation

Title: On Dredging and the Reuse of Sludge

Journal: Marine Voice 21, No. 169/Japan Dredging and Reclamation Engineering Association

Date: Jan 1993

Author: Honma Corporation (In Japanese)

Title: On a (Water Refresher) for a pressurized long distance sludge-feeding system for high-density dredging

Journal: Proceedings of the Study and Research, Niigata Section, Japa

Date: Mar 1993

Honma Corporation, Water Refresher HD-110

06-Jan-98

TechID: 254

Technology Type: Hydraulic

System Works With:

Development Stage: Full Scale Demo

Country Of Origin: Japan

Description:

The HD-110 is a dredger designed with the maximized features of the No. 1 Water Refresher and a special sludge suction unit, making thin-layer dredging possible. The main features of the unit are as follows:

- The special sludge-suction unit reduces the spread of turbidity during dredging, enabling the efficient thin-layer dredging of high density sludge.
- The high-pressure pump used in this system has enabled the long-distance pressurized feeding of high-sludge-content soil (approximately 10 km).
- The system can be easily assembled and is portable for operations in various areas, such as oceans, lakes and ponds.

The HD-110 is portable and can be disassembled for overland hauling by 10-tonne truck and trailer. The system can also be used in closed-water areas such as lakes and ponds, or the sea.

The thin-layer dredging method using the Water Refresher HD-110 was awarded the Technology Evaluation Certificate for (High-Density Sludge Dredging and Discharging Method) by the Ministry of Transport.

Limitations:

Type of Power:

Government Funding:

Environmental Concerns:

Health & Safety Plan Available:

Regulatory Approvals

Setup/Feed: Mobilization (days):
Removal Rate Average (m³/hr): 50

Demobilization (days):

Cost: Capital Cost (US\$):
Unit Cost (US\$/m³): -

Average Cost (US\$/m³): \$26.00

The estimated cost (only for direct work expense) is for dredging only. This cost does not include expenses involved in the transportation, assembly, and disassembly of the dredger.

Developers:

Honma Corporation
Engineering Division
Niigata City, 951,
Japan
Notes

Contact: Corporate Civil Engineering Dept.,
Phone: 81252298440 Ext:
Fax: 81252294726
Email:

Literature References:

- Author: Honma Corporation
Title: On a Special Dredging Unit of the Water Refresher for High-Density Dredging and a Long-Distance Pressurized Feeding
Journal: System
Japan Society of Civil Engineers, pp. 425-428
Date: Nov 1992
- Author: Honma Corporation
Title: Water Refresher System
Journal: Marine Voice 21 '93, No.174, pp. 71-78 , Japan Dredging and Reclamation Engineering Association
Date: Nov 1993
- Author: Ministry of Transport, Ports & Harbors Bureau
Title: Evaluation of a High-Density Sludge Dredging and Discharging Method (Part 2)
Journal: No. 211 Working Ship, pp. 34-47, Japan Working Ship Association
Date: Nov 1993
- Author: Ministry of Transport, Ports & Harbors Bureau
Title: Evaluation of a High-Density Sludge Dredging and Discharging Method (Part 1)
Journal: No. 210 Working Ship, pp. 34-47, Japan Working Ship Association
Date: Nov 1993

Technology Type:

System Works With:

Development Stage: Full Scale Demo

Country Of Origin: The Netherlands

Description:

The IHC environmental dredger was installed on an adapted standard Beaver 600 demountable cutter suction dredger equipped with a spud carriage system.

Limitations:

Type of Power:

Government Funding:

Environmental Concerns:

Health & Safety Plan Available:

Regulatory Approvals

Setup/Feed: Mobilization (days):

Demobilization (days):

Removal Rate Average (m³/hr):

Cost: Capital Cost (US\$):

Unit Cost (US\$/m³):

-

Average Cost (US\$/m³):

Developers:

IHC Holland N.V.
3360 AE Sliedrecht
,
The Netherlands
Notes

Contact:

Phone: 31184011555

Ext:

Fax: 31184011884

Email:

Literature References:

LWT Inc., Liquid Waste Technology Inc., Pit Hog Dredges

20-Jan-98

TechID: 351

Technology Type: Hydraulic

System Works With: Debris, Water Depth 2-10m, Limited Shore Access, Water Depth < 2m

Development Stage: Commercial

Country Of Origin: USA

Description:

Liquid Waste Technology (LWT) manufactures/provides dredges, lagoon pumpers, robotic tank and rail car cleaning systems, digester and tank cleaning systems and custom systems for slurry and solids removal.

LWT builds full size horizontal dredges and manned lagoon pumping systems. LWT specializes in automated, remotely controlled, lagoon pumping systems utilizing electronic or radio control including PLC (Programmable Logic Controller) software. LWT provides diesel or electric powered hydraulically powered machines with electronic and/or remote controls for solids handling systems for government, and industry.

LWT is called upon by clients for innovative specialized machinery for slurry handling applications, such as track driven submersible crawling units for pumping solids, silt and debris. LWT provides these units in a small size for tanks, and a larger size for lakes and lagoons.

LWT manufactures direct injection and spray equipment for high volume, cost effective land application of bio-solids for municipalities, industry and agriculture. LWT also builds a line of specialized agitators and submersible hydraulic pumps for livestock producers.

LWT makes equipment available for rental with option to purchase for customers who have a need for the equipment but cannot justify immediate purchase.

Limitations:

Type of Power: Units are Hydraulic/Diesel or Electric Power.

Government Funding:

Environmental Concerns:

Health & Safety Plan Available:

Regulatory Approvals

Setup/Feed:	Mobilization (days): 5	Demobilization (days): 5
	Removal Rate Average (m ³ /hr): 285	
Cost:	Capital Cost (US\$):	
	Unit Cost (US\$/m ³): -	Average Cost (US\$/m ³): \$27.00

Developers:

LWT Inc., Liquid Waste Technology
422 Main St., P.O.B. 250
Somerset, Wisconsin
USA 54025-
Notes

Contact: Mueller, Don
Phone: (715) 247-5464 Ext:
Fax: (715) 247-3934
Email:

Vendors:

LWT Inc., Liquid Waste Technology
422 Main St., P.O.B. 250
Somerset, Wisconsin
USA 54025-
Notes

Contact: Mueller, Don
Phone: (715) 247-5464 Ext:
Fax: (715) 247-3934
Email:

Literature References:

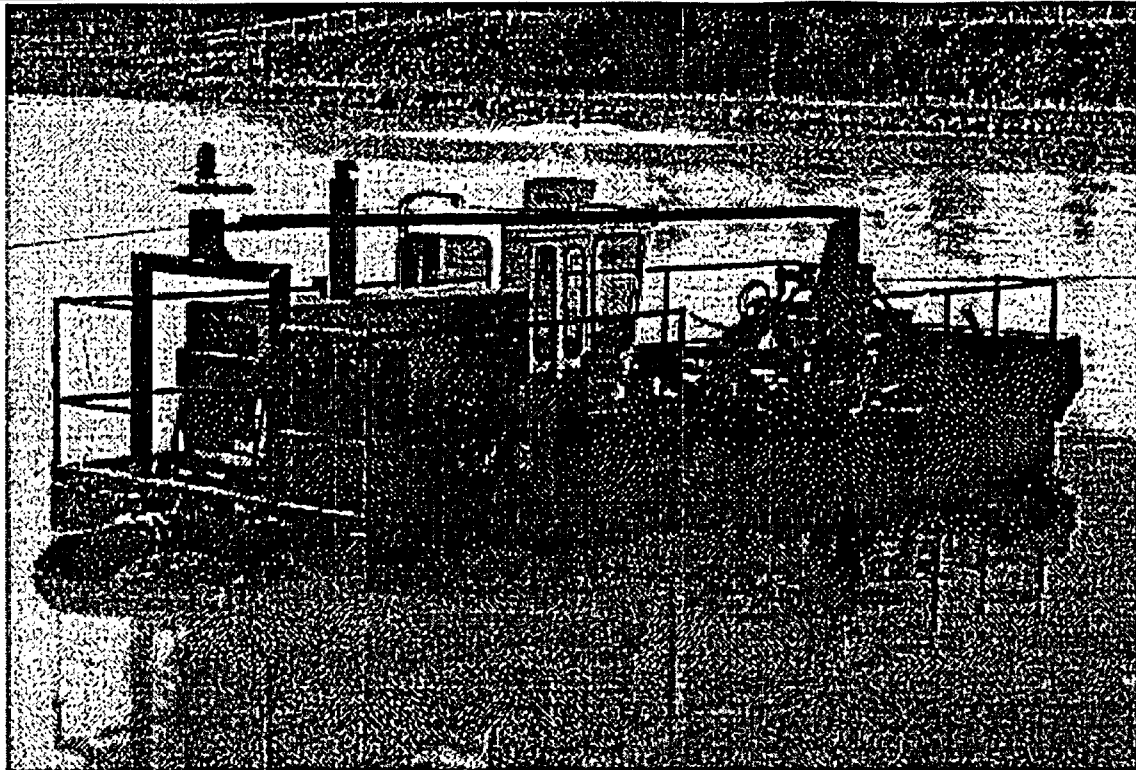

Project: City of Dallas

Location: Dallas, Texas, USA

Year 94

Full Scale Demo

Client/Funding Agency	Contact	Phone
City of Dallas		

Not Monitored

Removal Rate(m³/hr): 285 Amount Removed In-Situ (m³): 18000

Removal Cost(US\$): \$480,000.00

Mobilization (days): 5 Demobilization (days): 5

Site Conditions: Sedimentation Lagoon

Contaminants Present: None

Water Quality: WWTP Sludge

Turbidity:

Total Suspended Solids:

Percent Solids: 6%

Site Containment Used? No Yes

Exceed Set Standards?

Description: Horizontal Auger Dredge used for this project. Pit Hog Series 7MAU dredges are built for cost effective operations combined with simple maintenance and service requirements. These machines are compact and portable with foam-filled, 10-gauge steel pontoons maintaining minimum operational draft requirements. The unique, efficient, horizontal auger head and submerged chopper or vortex pumps assure high pumping rates of viscous, heavy solids, slurry residuals, pulp, silts, and sands. For lagoons with hazardous wastes or specific pumping conditions, Pit Hog units can be remotely controlled from shore. These systems may be operated with the lagoon in or out of service and are available with accessories and customized options.

Nautilus Dredging and Docks, STUMP

20-Jan-98

TechID: 341

Technology Type: Hydraulic

System Works With: Strong Currents, Water Depth < 2m, Water Depth > 10m

Development Stage: Commercial

Country Of Origin: USA

Description:

The STUMP is like a diving bell. It is a cylinder 5' in diameter and 5' high. The cylinder contains an 8" intake and 8" discharge dredge pump and a 4" jet pump with (12) 1/4" jet nozzels to slurry materials. The pumps are powered by hydraulic motors and the power for the pump is supplied by hydraulic motor driver by a 177 H.P Cummins diesel engine mounted on a barge or shore. The STUMP is bouyed or ballasted by air, supplied by an air compressor or discharged with a three way valve. The STUMP can work vertically or be towed by crane, with or towboat. The dredge can pump up to 300 c.y. per hour inflowing material.

Limitations: Can work on dry land when external water is supplied. The pump has worked down to 600'. The STUMP can work in any conditions except rock

Type of Power: Diesel powered hydraulic system.

Government Funding:

Environmental Concerns: The STUMP does not create excessive turbidity.

Health & Safety Plan Available:

Regulatory Approvals

Setup/Feed: Mobilization (days):

Demobilization (days):

Removal Rate Average (m³/hr): 130

Cost: Capital Cost (US\$): \$75,000.00

Unit Cost (US\$/m³): -

Average Cost (US\$/m³): \$7.60

For removal rate, assuming a head of 3 m above the water, 300 m distance and sandy or silty material - then maximum output 230 m³/hr. If slurriable, then reduce rate to 75 m³/hr. If lots of debris (gravel, rock), then reduce rate to 40 m³/hr.

Developers:

Nautilus Dredging and Docks
5875 Cobblestone Ln. D-102
Naples, FL
USA 33962-
Notes

Contact: Batchelder, George W.
Phone: (941) 774-1785 Ext:
Fax: (941) 793-8379
Email:

Vendors:

Nautilus Dredging and Docks
5875 Cobblestone Ln. D-102
Naples, FL
USA 33962-
Notes

Contact: Batchelder, George W.
Phone: (941) 774-1785 Ext:
Fax: (941) 793-8379
Email:

Literature References:

Technology Type: Hydraulic, Mechanical

Combination backhoe/hydraulic suction dredge.

System Works With: Debris, Strong Currents, Water Depth 2-10m, Limited Shore Access, Water Depth < 2m**Development Stage:** Commercial**Country Of Origin:** Canada**Description:**

The name "Amphibex" comes from the linkage of the two words "Amphibious" and "Excavator". The Amphibex is mainly an amphibious excavator.

The maximum length of the machine is 10.85 m, with an approximate working weight of 18 metric tons. Its approximate speed on water (with the propeller) is 9 knots. The transport length, width and height are 12.85 m, 3.50 m and 3.20 m, respectively. The maximum depth and reach is dependant on the length of the stick used. Using the standard stick that comes with the Amphibex, the depth and reach are 6.53 m and 7.86 m, respectively. Adaptable telescopic sticks can also be attached to the Amphibex for deeper water projects.

There are many great advantages with the Amphibex. To mobilize the Amphibex to a site, only a float van is required. Once on site, the Amphibex will lift itself up and the float can then move away. The Amphibex will then "walk" and float or crawl to the work site.

The production of the Amphibex, as for other dredging technologies, will fluctuate depending on the quality of the material, the quantity of debris, the pumping distance and the thickness of material to be removed. It is obvious that heavier sediment will affect the production rate during hydraulic dredging, both this effect will be minimal during mechanical dredging. Production rates during mechanical dredging has been estimated to be in the order of 50 m³/hr with a cycle time of less than 1 minute. During hydraulic dredging, the production rates in heavy material such as mill-scale (specific gravity of close to 5) fluctuated greatly depending mostly on distance. During the Welland River Reef Cleanup project (see Case Study), the production rate in pure mill-scale has fluctuated from 13 to 40 m³/hr and as high as 120 m³/hr at some occasions. Dredging in sand has showed production rates of approximately 70 m³/hr with some peaks at 150 m³/hr. Dredging in silty material has showed production rates of at least 100 m³/hr.

One of the most interesting aspect of dredging hydraulically with the Amphibex is the solids content in the dredged slurry. Since the pumps used by the Amphibex are located on the bucket (underwater), it is possible to obtain percentage of solids greater than 45% on a fairly constant basis. During the Welland River Reef Cleanup Project, it was found that, when the Amphibex was dredging silt, the addition of flocculant at the disposal site was useless since the solids content was too high (basically at the in-situ level). When dredging sand, solids content will remain constantly between 40 and 50%. Hard clay can also be hydraulically dredged with the Amphibex' special bucket. The slurry will then contain chunks of clay at also a high solids content.

Cost Quotation

Standard cost to dredge 20,000 m³ of sediment could be as low as 6.50 \$(US)/m³ for uncontaminated silt, or as high as 22 \$(US)/m³ for contaminated clay. Each cost will be site specific and dependent on the promoter's requirements.

Capital Cost (dredging only)

- Uncontaminated silt : 100,000 to 200,000 \$(US)

- Contaminated clay : 300,000 to 450,000 \$(US)

Unit Cost (dredging only)- Uncontaminated silt : from 6.50 \$(US)/m³ to 12 \$(US)/m³ with an average of approximately9 \$(US)/m³- Contaminated clay : from 15 \$(US)/m³ to 22 \$(US)/m³ with an average of approximately17 \$(US)/m³.

Limitations: The Amphibex is adaptable to almost any situations. Longer sticks and spuds can be added on the machine, smaller or larger bucket or pumping bucket can be manufactured and placed on the Amphibex, the engine and the hydraulics can also be adapted to suit any site specific requirements.

As mentioned in the above section, the standard Amphibex has a depth limitation of 6.4 m. As for any other technologies, the production rate of the standard Amphibex is also limited to a certain maximum which varies under different site specific conditions. The heaviest that the standard Amphibex will lift is approximately 5 tons.

Type of Power:

The driving force of the Amphibex is a Series 40 Detroit Diesel Engine. This engine can be replaced by a Volvo engine or others depending on the needs and/or the convenience. The pumping bucket uses Volvo hydraulic pumps located directly on the bucket. These pumps are actually positive displacement pumps. Contrary to a standard excavator, each Amphibex hydraulic function has its own hydraulic pump for more power and greater precision.

Government Funding: Great Lakes Cleanup Fund

Environmental Concerns: As for any other dredging technologies, the potential impact from sediment re-suspension is present, although the unique pumping system that comes with the Amphibex tends to reduce significantly this impact.

Other dredging technologies use standard hydraulic. The Amphibex uses 100% biodegradable natural oil, therefore decreasing the potential impact related with oil leaks or spills.

In fact, the Amphibex will reduce environmental impacts since it is small, quiet, versatile, can work easily in shallow waters. It also does not need any shore anchoring system, and does not require any parallel equipment for mobilization, dredging or demobilization. It is obvious that the less equipment is brought on site, the less impact the operations will have on the surrounding environment.

Health & Safety Plan Available:

Regulatory Approvals Different types of approvals are required to carry any dredging projects. The use of the Amphibex does not require any additional approvals than those required for standard dredging projects. The following is a list of approvals required to perform dredging project in Ontario :

Federal Jurisdiction Projects

- Canadian Coast Guard, Department of Transport
 - a) Approval to "Dredge in a Navigable Waterway under Section 5(2) of the Navigable Waters Protection Act (NWPA), RSC 1985, Chapter N-22".
- Department of Fisheries and Oceans (DFO)
 - a) Approval under Section 33 of the Fisheries Act.
- Federal Environmental Assessment and Review Office
 - a) Approval under the Canadian Environmental Assessment Act.

Provincial Jurisdiction Projects

- Ministry of Natural Resources (MNR)
 - Lakes & River improvements Act
 - Fisheries Act
- Ministry of the Environment and Energy
 - Environmental Protection Act

Setup/Feed:	Mobilization (days):	Demobilization (days):
	Removal Rate Average (m ³ /hr): 40	
Cost:	Capital Cost (US\$): \$200,000.00	
	Unit Cost (US\$/m ³): \$6.50 – \$22.00	Average Cost (US\$/m ³): \$14.00

Developers:

Normrock Industries Inc.
3360, boulevard des Entreprises
Terrebonne, PQ
Canada J6X4J8
Notes

Contact: Grant, Norman
Phone: (514) 477-5132 Ext:
Fax: (514) 477-2020
Email:

Vendors:

Normrock Industries Inc.
3360, boulevard des Entreprises
Terrebonne, PQ
Canada J6X4J8
Notes

Contact: Grant, Norman
Phone: (514) 477-5132 Ext:
Fax: (514) 477-2020
Email:

Literature References:

- Author: Gloria Flannery
Title: Ice Breaking Operation Underway
Journal: Bangor Daily News
Date: Mar 1995
- Author: Robert B. Hachnel, U.S. Army Corps of Engineers
Title: Breaking River to Prevent Ice Jams
Journal: Ice Engineering, # 11
Date: Oct 1995
- Author: Les Consultants en Environnement Argus Inc.
Title: Suivi de la performance technique et environnementale de l'Amphibex
Journal: Report for Environment Canada - Québec Région and Environment Québec
Date: Mar 1996

Normrock Industries Inc., Amphibex

20-Jan-98

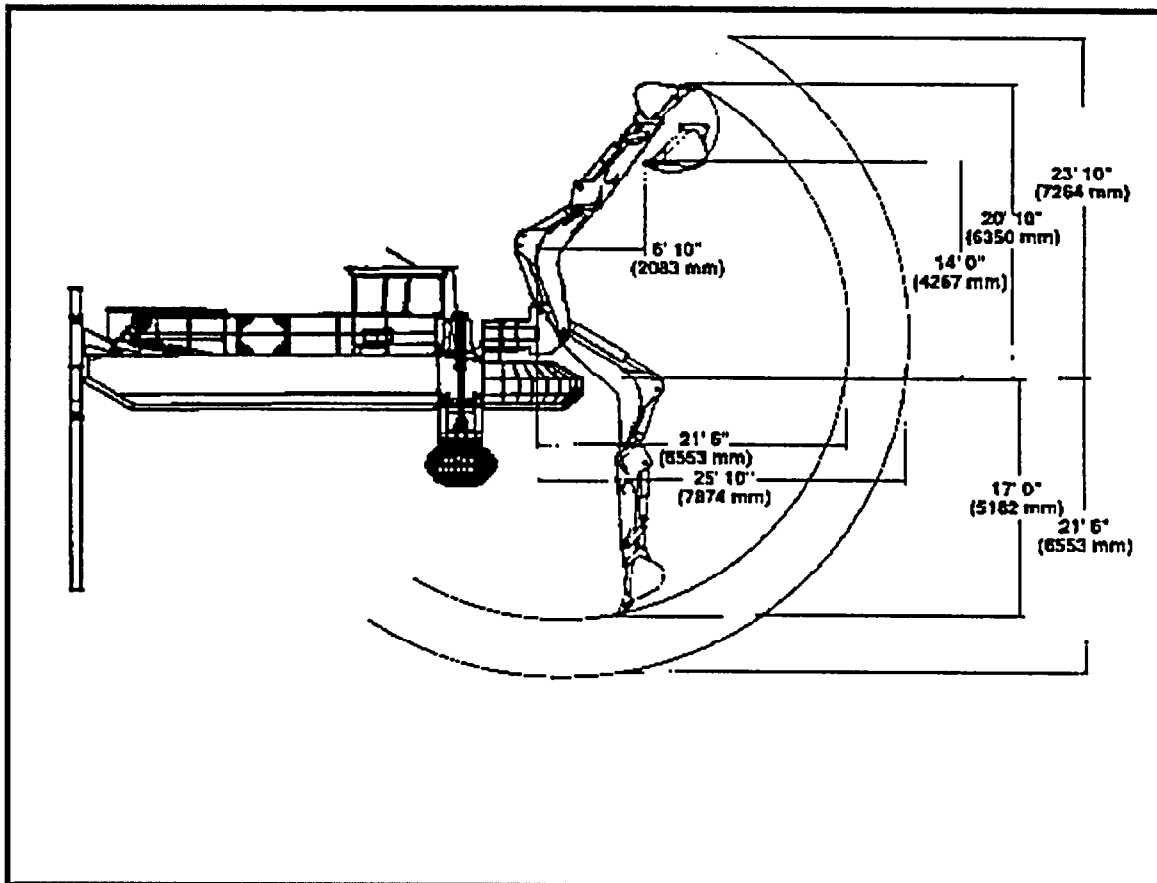
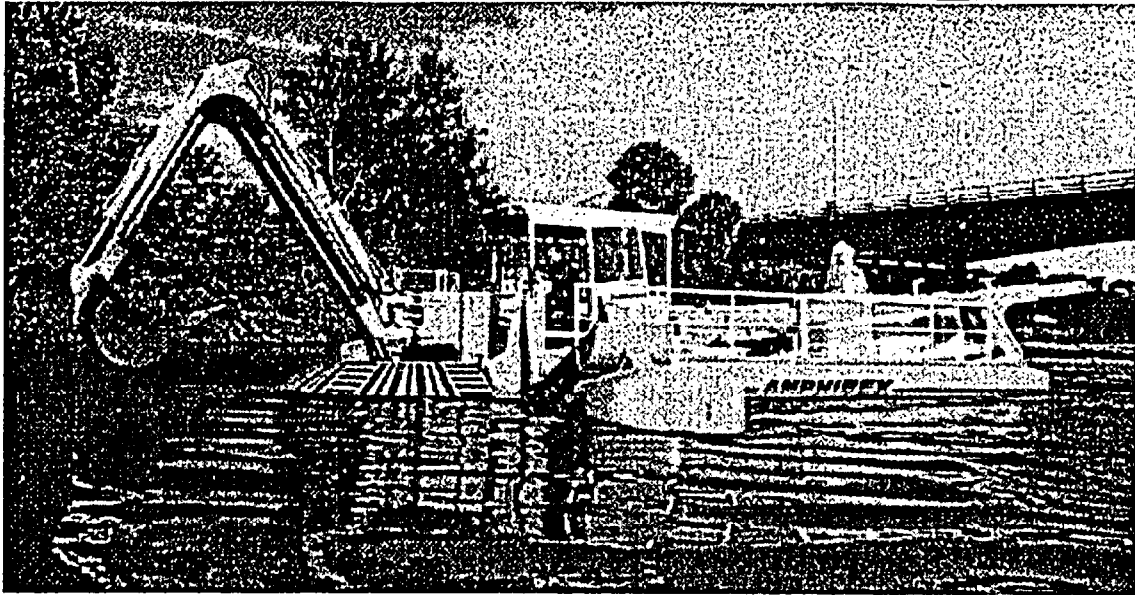

Normrock Industries Inc., Amphibex

20-Jan-98

Project: Dunker's Flow Balancing System - Sediment Removal Demonstration

Year 95

Location: Bluffer's Park, Scarborough, Ontario, Canada

Full Scale Demo

Client/Funding Agency	Contact	Phone
Remediation Technologies Program/Great Lakes Cleanup Fund City of Scarborough	Ian Orchard	(416) 739-5874

Not Monitored

Removal Rate(m³/hr): 40 Amount Removed In-Situ (m³): 35000

Removal Cost(US\$): \$320,128.00

Mobilization (days): 3 Demobilization (days): 1

Site Conditions: Scarborough is located just east of the city of Toronto, and is part of the Metropolitan Toronto and Region Area of Concern (AOCs). Erosion from the Scarborough Bluffs is a major source of suspended solids to Lake Ontario. Another problem associated with the Scarborough Bluffs is the storm sewer and occasional combined sewer overflows that discharge in Bluffers Park and ultimately to Lake Ontario.

As part of the Water Quality Enhancement Strategy for the Brimley road drainage area (storm sewer source to Bluffers Park), a Dunkers Flow Balancing System has been proposed within the Bluffers Park embayment. Construction of this facility will require dredging of sediment currently in the embayment. The quality of the sediment was determined to identify acceptable disposal methods according to the Ontario Ministry of the Environment and Energy Guidelines for the protection and management of aquatic sediment quality.

The dredging site, Bluffers Park embayment, covers an area of approximately 200 m x 125 m (25,000 m²). The average water level is 74.7 m, with a minimum of 74.1 m (April, 1964) and a maximum of 75.5 m (July, 1973). The current average water depth at Bluffers park embayment was measured at 74.2 m.

In order for the proposed retention basin to contain a 1-year storm event, the volume of the basin must be in the order of 40,000 m³, therefore requiring up to three (3) meters of sediment removal, with slopes of 5:1 in order to ensure shoreline integrity and appropriate bed for planting. It is expected that a volume of 35,000 m³ will be removed in order to provide adequate retention for the 100-year storm event.

Contaminants Present: Except for some samples indicating elevated levels of alkalinity (8.05), the sediment was found to be acceptable for unrestricted land uses.

Water Quality: The water quality of the embayment is mostly dependent on the weather. During storm event, water from street runoffs is discharged directly into the embayment through a storm water outlet. The quality of the water is also regulated by Lake Ontario's water level. When the level is high, fresh water from the lake enters the embayment. When the water level is low, warmer water from the embayment is discharged directly to Lake Ontario. Eventhough water quality data are not currently available, it is expected that levels of nutrients and bacteria are elevated during late spring, through the summer and at the beginning of the fall.

Turbidity: No water quality monitoring was performed during this project.

Total Suspended Solids: No water quality monitoring was performed during this project.

Percent Solids: The percentage of solids (by volume) was measured several times during this project. A densitometer was also calibrated with material from the embayment. Results from samples have indicated percentages of solids (by volume) varying from 40 to 50%. The results from the densitometer have indicated percentages of solids (by volume) greater than 40%, constantly (when measured).

Site Containment Used? No Yes

The dredge site (embayment) was isolated from Lake Ontario through the use of a rock check dam which controlled water movement between the embayment and the lake.

Exceed Set Standards? not applicable

Description: This project was the first phase in the construction of a Dunkers Flow Balancing System, which will serve to collect and treat a portion of the City of Scarborough's storm water. It is believed that, once in place, this system will serve to improve the water quality in the Metropolitan Toronto and Region Area of Concern.

Removal Rate:

The demonstration project consisted of : a) excavation of 35,000 m³ of unconsolidated bottom material consisting mainly of loose clayey-silt overlaying fine to coarse sand, b) transport of excavated material from the waterbody to a temporary holding facility.

Due to the nature of the material to be removed and the difficulties associated with dredging in a parkland, an INNOVATIVE amphibious dredging technology (Amphibex) was used. This technology minimized disturbance of the surrounding park. The material was safely pumped into a temporary in-water holding facility and then transferred into a temporary on-land holding facility where it naturally dried. The dry material was then trucked to a disposal area.

A temporary in-water holding facility was built in order to contain the dredged material and to decrease the amount of water brought on land.

The removal rate was affected by severe problems that occurred during dredging: 1) the presence of large debris such as

Normrock Industries Inc., Amphibex

20-Jan-98

logs, bicycles, boat anchors, large rocks, etc. affecting the production rate, 2) large quantities of gravel in some areas of the embayment contributing to the fast erosion of the pumps impellers, 3) erosion from the Scarborough Bluffs and storm water entering the embayment contributed to the addition of material during dredging.

Another major problem encountered was the fact that the requested final elevation was below the original grade of the park. Bluffer's park was created in the '70s by lakefilling with all kinds of material. Therefore, in order to achieve the requested grade, the contractor had to remove a large portion of the fill material.

The contractor also changed the pumping bucket after 58.5 hours of dredging. Production rates were calculated after 366 hours of dredging. The production rate with the old pump was 30 m³/hr, and approximately 50 m³/hr with the new pump.

Amount Removed in-situ (m³):

Post-dredging soundings have indicated that 35,000 m³ has been removed from Bluffer's Park embayment. This volume does not incorporate the amount of material that entered the dredging site through bluffs erosion and storm water. Therefore, the volume pumped and the volume measured by soundings are different. It was estimated that the volume of material pumped was approximately 43,000 m³.

Removal Cost :

The total cost for mobilization, dredging, trucks loading and demobilization was 320,128 \$(US), leading to a unit cost of 9.15 \$(US). The unit cost for dredging only was 6.48 \$(US).

Mobilization Time (days) : 3

Mobilization started on 21 May 1995 with the arrival on site of the utility trailer. The Amphibex arrived on site on 23 May 1995. The first duty on 24 May 1995 was to build an in-water cell to be used to contain the pumped material. A backhoe and the Amphibex was used to create this cell. This activity ended the same day.

The following is a list of equipment brought on site by the contractor :

- 1 Amphibex (amphibious dredge)
- 1 Backhoe (Case 125)
- 1 Service Boat with 9.9 motor
- 1 Pumping Bucket
- 1 Conventional Bucket
- 1 Silt Curtain
- 1 Pipeline (500 m x 20 cm)
- 1 Temporary Office with Communication and Power

Demobilization Time (days) : 1

Demobilization started on 11 December 1995 and ended on 15 December 1995 and consisted mainly on the removal from the site of the Amphibex, the utility trailer and the excavator.

Regulatory Approvals :**Federal Government:****Canadian Coast Guard, Department of Transport:**

a) Approval to "Dredge in a Navigable Waterway under Section 5(2) of the Navigable Waters Protection Act (NWPA), RSC 1985, Chapter N-22".

- Department of Fisheries and Oceans (DFO)

a) Approval under Section 33 of the Fisheries Act.

Federal Environmental Assessment and Review Office

a) Initial Screening of the proposal undertaking in keeping with the requirements of EARP.

Provincial Approvals:

- Ministry of Natural Resources (MNR)
- Public Lands Act (not required for removal operations)
- Lakes & River improvements Act (not required since the water is federal)
- Ministry of the Environment and Energy
- Environmental Protection Act

Affected Property Owner

- City of Scarborough

Monitoring : No water quality monitoring was performed during this project.

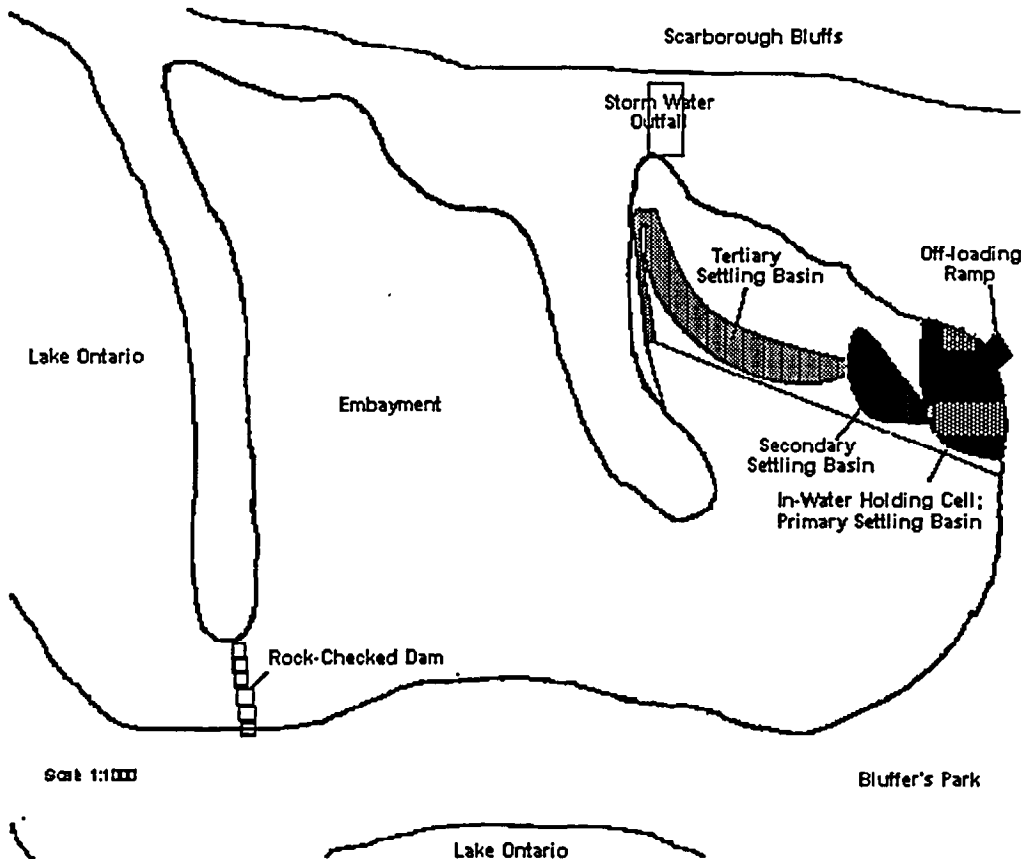

Project: Welland River Reef Cleanup Project

Location: Welland River, Welland, Ontario, Canada

Year 95

Full Scale Demo

Client/Funding Agency	Contact	Phone
Remediation Technologies Program/Great Lakes Cleanup Fund Atlas Specialty Steels	Ian Orchard Don Marr	(416) 739-5874 (905) 735-5661

* Monitored * Auditor: Acres International Limited Phone: (905) 374-5200

Removal Rate(m³/hr): Amount Removed In-Situ (m³):

Removal Cost(US\$): \$274,400.00

Mobilization (days): 7 Demobilization (days): 3

Site Conditions: The dredging sites were located on the lower reach of the Welland River. The area offshore from the McMaster Avenue municipal sewer outfall which is one of several existing municipal, industrial and residential outfalls on the east bank of the river in the area. The other area was at a 42" industrial outfall located approximately 0.5 km downstream from McMaster Avenue. The dredge site is generally residential or parkland.

The width of the Welland River varies from approximately 40 to 60 m. The maximum depth of water is approximately 4 m. Historical average river flow ranges from approximately 14.2 m³/s in June/July to 24.6 m³/s in March, corresponding to current velocities of 0.15 to 0.26 m/s. Due to downstream flow controls, the river undergoes apparent flow reversals on a daily basis.

Past industrial discharges through the McMaster Avenue and the 42" outfall have resulted in two accumulations of reef-type deposits of oily, black, fine to coarse granular, metallic industrial mill-scale, totalling approximately 5,000 m³. The maximum thickness of the industrial deposits is approximately 2.5 m.

Approximately 25,000 m³ of clay and silt river sediments have also been variably impacted by the contaminated discharges.

The mill-scale and the contaminated sediment contain concentrations of several metals, including copper, chromium, iron, lead, manganese, nickel and zinc, as well as phosphorus and oil and grease which exceed the Ontario Ministry of the Environment & Energy (OMOEE) sediment quality guidelines.

Two zones requiring sediment removal were identified. At the McMaster Avenue outfall, original surveys

Normrock Industries Inc., Amphibex

20-Jan-98

had indicated that approximately 1,500 m3 of mill-scale and river sediment were contaminated and required removal. At the 42" outfall, the volume of sediment to be removed had been estimated at 5,500 m3.

Contaminants Present:	Contaminants	Max. Concentration (ug/g, dry)	LEL (ug/g)	SEL (ug/g)
	Chromium	5,000	26	110
	Copper	860	16	110
	Iron	380,000	20,000	40,000
	Lead	870	31	250
	Manganese	6,900	460	1,100
	Nickel	11,000	16	75
	Zinc	1,300	120	820
	Oil & Grease	45,300	---	---

The LEL and the SEL are both guidelines established by the Ontario Ministry of the Environment & Energy for the protection and management of aquatic sediment quality in Ontario. The LEL represents the lowest concentration where a contaminant will have an effect on benthic organisms, while the SEL is the concentration where contaminants will have a detrimental effect to the majority of benthic organisms. The SEL for PAHs is also dependent on the concentration of total organic carbon.

Water Quality: Results from sampling performed in 1990 indicate that, from the 32 parameters analyzed, only aluminum, copper, total phosphorus and total phenols exceed the Provincial Water Quality Objectives for the Protection of Aquatic Life within the vicinity of the demonstration area. Iron levels were exceeded both upstream and downstream of the study site, but not within. The high aluminum concentration may be due to the suspended clay content of the water, since the Welland River drains in an area of predominantly clay soils.

Turbidity: Turbidity was measured in-field to establish shutdown criteria for the dredging operation. The monitoring program consisted mainly on the comparison of turbidity results downstream from the dredge with the results from ambient levels (samples taken 50 to 100 m upstream). Turbidity results were obtained using two different tools. The first tool was an Hydrolab, which constantly measures turbidity at specific intervals. A Van Dorn sampler was also used to collect grab samples. Sub-samples were then fed to a turbidity meter.

The results have indicated that the ambient level fluctuated greatly with weather conditions. For most of the duration of the project (until 04 November 1995), the ambient turbidity level was below 40 FTU. The results from the turbidity measurements from downstream of the dredge indicated only 1 exceedance of the guideline (increase of approximately 30 FTU from ambient level on 27 October 1995). From 04 November 1995 until the end of the project (19 December 1995), the weather conditions varied greatly, having an effect on river currents which in turn had an effect on the silt curtain. From 04 November 1995, the ambient level varied from 50 FTU to 400 FTU with exceedances of guidelines noted on 04 November, 11 November and 06 December. These exceedances were mostly due to the following factors : 1) increased river currents lifting silt curtain, 2) external inputs, and 3) more emphasis put towards production.

Total Suspended Solids: The total suspended solids results (TSS) slightly differs from the turbidity results. TSS results show less frequent exceedances of guidelines. The could be attributed to the fact that TSS concentration does not take into account the water coloration from the oil present in the water column. The sediment from the removal areas had extremely elevated concentrations of oil and grease. Some of this oil and grease did escape from the dredge suction head and contributed to the increase of turbidity results.

Percent Solids: Percent solids was measured using through nucleonic densitometer readings and slurry sampling. Unfortunately, both methods provide underestimate of the actual percent solids in the slurry achieved by the Amphibex during the project. The densitometer was installed on the Amphibex, but due to a lack of space could only be placed in an horizontal manner instead of a 45 degree angle. Slurry sampling was performed at the treatment plant after primary screening of the slurry through a scalping screen.

Densitomer readings indicated an average percentage of solids of approximately 18 % with instantaneous peaks greater than 80 %. Slurry sampling indicated percent solids averaging approximately 8 % with a maximum of 18.8 %. The material being heavy and coarse, a great amount was able to flow underneath the densitometer beam located in the middle of the pipeline, and also, a good portion (up to 40 %) was removed by the scalping screen.

Site Containment Used? No Yes

Exceed Set Standards? The Remediation Technologies Program of Environment Canada has developed a set of standards in order to audit demonstrated innovative sediment removal technologies. The following are those standards :

Sediment Removal Phase :

- 1) Turbidity: Turbidity beyond a distance of 25 m of the actual removal location shall not exceed ambient levels by more than 30%.
- 2) Suspended Solids: Beyond a 25 m distance of the actual removal location, suspended solids shall not exceed ambient levels by more than 25 mg/l.
- 3) Total Organic Carbon: Total Organic Carbon (TOC) content should be within the range of 0.4-27 mg/l in surface water beyond 25 m of the removal operation. TOC shall not exceed background levels by more than 30% when background concentrations are greater than 27 mg/l.
- 4) No Overflow or Leaks: A minimum freeboard of 1 m must be maintained in the hopper of holding facility for the excavated sediment. The holding facility must be sealed for transport to the pre-treatment/disposal site.
- 5) Removal Efficiency: The solids to liquids ratio in the excavated material should be at least 30% by volume.

Normrock Industries Inc., Amphibex

20-Jan-98

6) Effluent Quality: Maximization of solids removal is paramount. Solids suspended in the slurry mixture must be removed by some means, either mechanical or chemical (flocculation). If the extracted material is fine grained, provision should be made to treat the effluent.

7) Production Rate: The production rate of the sediment removal equipment should be adjusted to show sufficient settling time for effluent to meet the Provincial Water Quality Objectives (PWQOs). Therefore, the feed rate of the excavated material into the holding facility for transport to the pre-treatment disposal area should be adjusted accordingly.

Transport Phase:

1) No Overflow or Leaks: No overflow or leaks of excavated material shall be allowed during transport to the disposal or pre-treatment area. Use of pipelines or other fully closed transport mediums is encouraged.

2) Transport Rate: The rate of material being transported must be adjusted to meet the handling capacity of the pre-treatment or disposal facility.

3) Contact: No contact is permissible between the contaminated sediment and human, bird and aquatic life.

Pre-Treatment Phase :

1) Effluent Quality: Effluent quality of the supernatant water and effluent from the pre-treatment process should meet applicable federal and provincial standards and guidelines.

2) Waste Handling: All wastes from the pre-treatment process should be handled and disposed of in accordance with appropriate regulatory requirements.

In addition to Environment Canada's standards for the evaluation of the dredge, the OMOEE and the OMNR had requirements in order to protect the aquatic life. The OMNR standard was based on a limit of 10 % or 25 mg/L increase from ambient level of the total suspended solids concentration downstream of the silt curtain. The OMOEE guideline was based on an increased of turbidity levels of 80 FTU from ambient levels 100 m downstream of the silt curtain.

These guidelines were exceeded at some occasions due mainly to external sources, the presence of high concentration of debris causing shutdown of dredging and sediment re-suspension related to lifting of pumping bucket, etc.

Description: This project was the first major Canadian site remediation project of significance. It is believed that the results from this project will be used to cleanup other Areas of Concern on the Canadian side of the Great Lakes.

Removal Rate :

For this project, an amphibious dredge, the Amphibex, was selected. This innovative dredge is manufactured by Normrock Industries Inc. from Terrebonne, Québec, Canada. This dredge is essentially a mixture of a barge equipped with spuds and stabilizers and an excavator. The hydraulic arm used to excavate is equipped with an innovative pumping bucket with the pumps located on the bucket. This unusual position for the pumps allows the Amphibex to hydraulically dredge sediment without requiring any negative pressure (suction); only positive pressure is applied on the slurry, leading to a greater percentage of solids and less excess water brought to the treatment site.

The removal rate was affected by three main factors : 1) the quantity of man-made debris, 2) the quality and thickness of the sediment, and 3) the pumping distance and total head. It was found that the quantity and size of debris was dependent on the site accessibility. At both the McMaster Avenue and 42" outfall dredging sites, the area close to the outfall was easily accessible. Debris such as shopping carts, bicycles, cans, steel rods, etc. were heavily concentrated to the extent that mechanical dredging using a long reach excavator had to be performed. Once the bulk of those debris was removed, the production increased.

The quality of the material greatly contributed to the production rate. Pumping of heavy mill-scale (specific gravity = 4.93) required the addition of excess water in order to provide the necessary velocity for transport to the treatment plant.

Distance was also a contributing factor to the production rate. The McMaster Avenue area was located 1.5 km away from the treatment plant, while the 42" outfall area was located 1 km from the treatment plant. Results have indicated that the production rate was lower at the McMaster Avenue site.

Table 1 summarizes the estimated production rates for different scenarios :

Table 1 : Production Rates for different scenarios:

Site:	Mill-scale with debris:	Mill-scale without debris:	River sediment:
McMaster Avenue	13 m3/hr	20 m3/hr	25 m3/hr
42" outfall	15 m3/hr	40 m3/hr	60-120 m3/hr

Amount Removed in-situ (m3) :

The original estimates for the volume of sediment requiring removal were 1,500 m3 and 5,500 m3, at the McMaster Avenue and 42" outfall areas, respectively. The final volumes removed during the project was 3,050 m3 and 6,783 m3, at the McMaster Avenue and 42" outfall areas, respectively. The difference in the original and final calculations could be attributed to two factors : 1) instability of slopes at the McMaster area, and 2) more oil & grease contaminated clay underlying the contaminated sediment than expected.

Removal Cost :

The total cost charged to the project by the contractor (excluding requested standby) 274,400 \$(US), which leads to a unit price of 27.91 \$(US)/m³. The unit price price for dredging only was 14.40 \$(US)/m³.

Mobilization Time (days) : 7

Mobilization started on 15 September 1995 with the installation and fusing of the pipeline. The booster pump was put in place on 20 September 1995. The installation of the silt curtain and pressure testing of the pipeline took place on 21 September 1995. Dredging commenced on 22 September 1995. The following is a list of equipment brought on site by the contractor :

- Amphibex (amphibious dredge)
- Pipeline (1,500 m x 0.20 cm)
- Booster pumps
- Silt curtains
- Office trailer

Demobilization Time (days) : 3

Demobilization and site cleanup started on 20 December 1995 and lasted until 22 December 1995 and consisted mainly on removing the pipeline, the booster pump, the Amphibex and the silt curtains from the site.

Regulatory Approvals :

As part of the project, several approvals and permits are required from various departments of the federal & provincial governments and property owners affected by the project.

Federal Government:**Canadian Coast Guard, Department of Transport:**

- Approval to "Dredge in a Navigable Waterway under Section 5(2) of the Navigable Waters Protection Act (NWPA), RSC 1985, Chapter N-22".

Department of Fisheries and Oceans (DFO):

- Approval under Section 33 of the Fisheries Act.

Federal Environmental Assessment and Review Office:

- Initial Screening of the proposal undertaking in keeping with the requirements of EARP.

Provincial Approval:**Ministry of Natural Resources (MNR)**

- Public Lands Act
- Lakes & River improvements Act
- Fisheries Act

Ministry of the Environment and Energy

- Environmental Protection Act

Affected Property Owner

City of Welland

Several land owners

An Environmental Screening Document (ESD) has been prepared and sent to the Project Planning Committee and members of the public for their review and comments.

The removal and transport technology and procedures was explained and presentation of the project by the RAP team, the Remediation Technologies Program and the Atlas Specialty Steels, Acres Internationa was performed during an open house in Welland that took place prior to the demonstration. The public was invited to attend, ask questions and raise any concerns they had. The questions and answers were provided in the final ESD as an attached Addendum.

During the open house, copies of the ESD were made available to the public. A final version of the ESD was sent to the reviewing committee and those members of the public who requested a copy during the open house.

Monitoring :

Water quality monitoring was performed by the Project Co-ordinator on behalf of Environment Canada and the Ontario Ministries of Natural Resources and Environment & Energy.

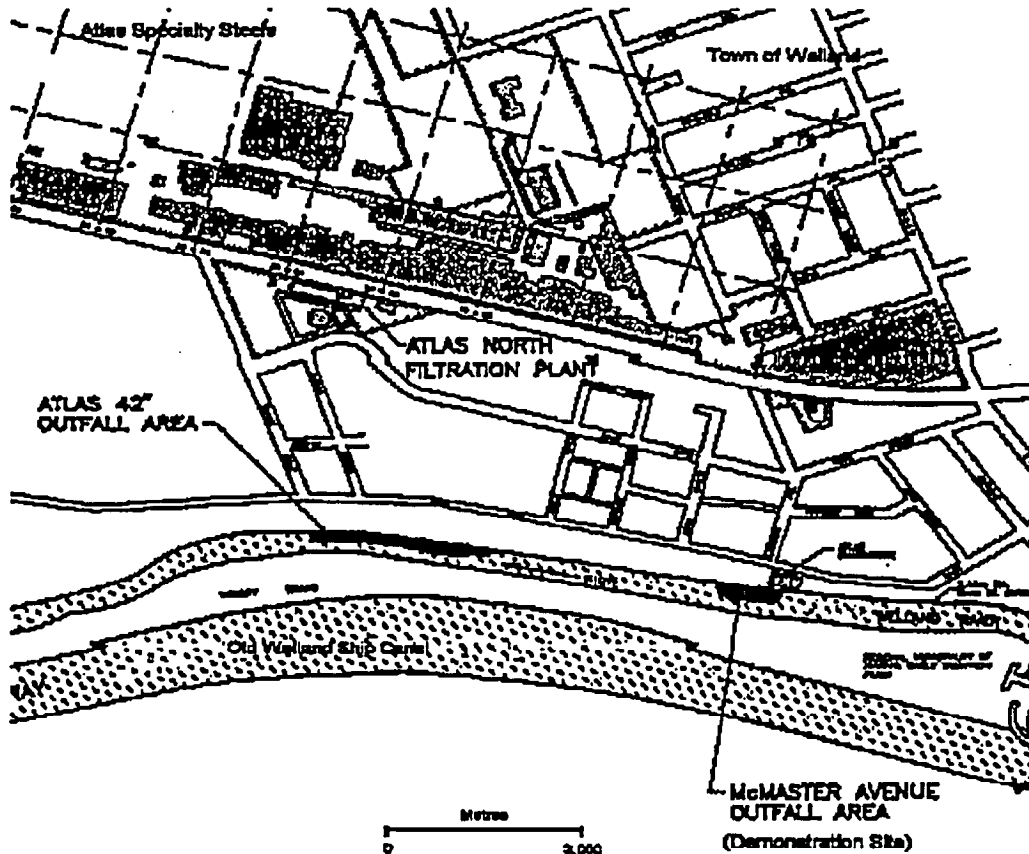

Project: Welland River Sediment Removal Demonstration

Year 91

Location: Welland, Ontario, Canada

Pilot Scale

Client/Funding Agency	Contact	Phone
Remediation Technologies Program/Great Lakes Cleanup Fund Atlas Specialty Steels	Ian Orchard (Environment Canada) Don Marr	(416) 739-5874 (905) 735-5661

* Monitored * Auditor: Acres International Limited Phone: (905) 374-5200

Removal Rate(m³/hr): Amount Removed In-Situ (m³): 127

Removal Cost(US\$): \$324,000.00

Mobilization (days): 7 Demobilization (days):

Site Conditions:

Contaminants Present:	Contaminants	Max. Concentration (ug/g, dry)	LEL (ug/g)	SEL (ug/g)
	Chromium	5,000	26	110
	Copper	860	16	110
	Iron	380,000	20,000	40,000
	Lead	870	31	250
	Manganese	6,900	460	1,100
	Nickel	11,000	16	75
	Zinc	1,300	120	820
	Oil & Grease	45,300	---	---

The LEL and the SEL are both guidelines established by the Ontario Ministry of the Environment & Energy for the protection and management of aquatic sediment quality in Ontario. The LEL represents the lowest concentration where a contaminant will have an effect on benthic organisms, while the SEL is the concentration where contaminants will have a detrimental effect to the majority of benthic organisms. The SEL for PAHs is also dependent on the concentration of total organic carbon.

Water Quality: Results from sampling performed in 1990 indicate that, from the 32 parameters analyzed, only aluminum, copper, total phosphorus and total phenols exceed the Provincial Water Quality Objectives for the Protection of Aquatic Life within the vicinity of the demonstration area. Iron levels were exceeded both upstream and downstream of the study site, but not within. The high aluminum concentration may be due to the suspended clay content of the water, since the Welland River drains in an area of predominantly clay soils.

Turbidity: Dredging in the original mode resulted in an overall average turbidity of 18.5 FTU at the dredge head compared to background turbidity of 5 FTU. Dredging without the shroud and with the standard auger

Normrock Industries Inc., Amphibex

20-Jan-98

resulted in an overall average turbidity of 17.6 FTU. Operating in a more flexible mode (more freedom to the operator) resulted in longer periods of dredging and less frequent plugging of the pipeline while still maintaining low turbidity levels at the dredge head (average 13.8 FTU). Operating without the screen resulted in the lowest turbidity levels at the dredge head (average 5.4 FTU) but also resulted in frequent blockage of the intake or dredge pump.

Total Suspended Solids: Total suspended solids (TSS) concentrations at a distance of 10 m away from the dredge were well below the Environment Canada criteria of 25 mg/L at a distance of 25 m. The maximum TSS concentration measured at a distance of 10 m away from the dredge from 21 mg/L.

Percent Solids: The overall average percent solids including mill scale and river sediment, in the pumped slurry was low (2.1 %, excluding rinsing) and varied considerably during the demonstration due to the structure of the dredging program (frequent starts, stops and flushing of the pipeline) and the generally cautious approach to the dredging to minimize environmental concerns. The removal of the intake screen increased the overall average percent solids to 3.7% while the removal of the dredge head shroud resulted in the highest overall average percent solids of 4.4%.

Site Containment Used? No Yes

A commercially available silt curtain was selected for the project and was modified by the manufacturer to meet specific demonstration requirements. It consisted of an impermeable polyester-reinforced vinyl fabric which extended the full depth of the water column. Segmented foam flotation members were fabricated into the full length of the top edge. Additional flotation units were fabricated by Atlas from empty barrels. The flotation units and the curtain were anchored in place by steel cables attached to concrete blocks placed on the river bed.

Exceed Set Standards? The Remediation Technologies Program of Environment Canada has developed a set of standards in order to audit demonstrated innovative sediment removal technologies. The following are those standards :

Sediment Removal Phase :

1) Turbidity: Turbidity beyond a distance of 25 m of the actual removal location shall not exceed ambient levels by more than 30%.

2) Suspended Solids: Beyond a 25 m distance of the actual removal location, suspended solids shall not exceed ambient levels by more than 25 mg/l.

3) Total Organic Carbon: Total Organic Carbon (TOC) content should be within the range of 0.4-27 mg/l in surface water beyond 25 m of the removal operation. TOC shall not exceed background levels by more than 30% when background concentrations are greater than 27 mg/l.

4) No Overflow or Leaks: A minimum freeboard of 1 m must be maintained in the hopper of holding facility for the excavated sediment. The holding facility must be sealed for transport to the pre-treatment/disposal site.

5) Removal Efficiency: The solids to liquids ratio in the excavated material should be at least 30% by volume.

6) Effluent Quality: Maximization of solids removal is paramount. Solids suspended in the slurry mixture must be removed by some means, either mechanical or chemical (flocculation). If the extracted material is fine grained, provision should be made to treat the effluent.

7) Production Rate: The production rate of the sediment removal equipment should be adjusted to show sufficient settling time for effluent to meet the Provincial Water Quality Objectives (PWQOs). Therefore, the feed rate of the excavated material into the holding facility for transport to the pre-treatment disposal area should be adjusted accordingly.

Transport Phase:

1) No Overflow or Leaks: No overflow or leaks of excavated material shall be allowed during transport to the disposal or pre-treatment area. Use of pipelines or other fully closed transport mediums is encouraged.

2) Transport Rate: The rate of material being transported must be adjusted to meet the handling capacity of the pre-treatment or disposal facility.

3) Contact: No contact is permissible between the contaminated sediment and human, bird and aquatic life.

Pre-Treatment Phase :

1) Effluent Quality: Effluent quality of the supernatant water and effluent from the pre-treatment process should meet applicable federal and provincial standards and guidelines.

2) Waste Handling: All wastes from the pre-treatment process should be handled and disposed of in accordance with appropriate regulatory requirements.

In addition to Environment Canada's standards for the evaluation of the dredge, the OMOEE and the OMNR had requirements in order to protect the aquatic life. The OMNR standard was based on a limit of 10 % or 25 mg/L increase from ambient level of the total suspended solids concentration downstream of the silt curtain. The OMOEE guideline was based on an increased of turbidity levels of 80 FTU from ambient levels 100 m downstream of the silt curtain.

Those standards were not exceeded during the demonstration.

Normrock Industries Inc., Amphibex

20-Jan-98

Description: Site Conditions:

The dredging site was located on the lower reach of the Welland River. The area offshore from the McMaster Avenue municipal sewer outfall which is one of several existing municipal, industrial and residential outfalls on the east bank of the river in the area. The dredge site is generally residential or parkland. Figure 1 shows study area.

The width of the Welland River varies from approximately 40 to 60 m. The maximum depth of water is approximately 4 m. Historical average river flow ranges from approximately 14.2 m³/s in June/July to 24.6 m³/s in March, corresponding to current velocities of 0.15 to 0.26 m/s. Due to downstream flow controls, the river undergoes apparent flow reversals on a daily basis.

Past industrial discharges through the McMaster Avenue and other nearby downstream outfall have resulted in two accumulations of reef-type deposits of oily, black, fine to coarse granular, metallic industrial mill-scale, totalling approximately 5,000 m³ (estimate from 1990). The maximum thickness of the industrial deposits is approximately 2.5 m.

Approximately 25,000 m³ of clay and silt river sediments have also been variably impacted by the contaminated discharges.

The mill-scale and the contaminated sediment contain concentrations of several metals, including copper, chromium, iron, lead, manganese, nickel and zinc, as well as phosphorus and oil and grease which exceed the Ontario Ministry of the Environment & Energy (OMOEE) sediment quality guidelines.

Removal Rate :

The Mud Cat 915 ENV was demonstrated in the shallow waters of Welland River. This technology was manufactured by Ellicott Machine Corporation of Baltimore, Maryland, United States, and owned and operated by Auburn Contractors Incorporated of Burlington, Ontario, Canada.

The dual convergence of the horizontal auger head, with an enclosed housing for the auger were the principal components to minimizing sediment resuspension. Other components to the operation included hydraulic vibrators to supplement the excavation, and removable front screens to restrict oversized material from obstructing the system.

Dredging started in the "original" (no modifications) mode and during the mode of the demonstration, numerous planned modifications were made to the dredge and the operating procedures to allow evaluation of the dredge in terms of slurry production yields and turbidity. These modifications included : 1) removal of the shroud screen to reduce ploughing of the sediment in front of the dredge head, 2) welding small steel bars across the suction intake to minimize the entry of debris, 3) installation of a check valve in the pipeline at the dredge discharge to minimize backflow, and 3) relocation of the shroud vibrators in an effort to impart a more horizontal action to the head.

Midway through the demonstration, the modified auger was replaced with the standard toothed auger and near the end of the demonstration, the auger shroud was removed.

The removal rate was not calculated at the time. Projected production rates for full-scale remediation were estimated at 10 to 20 m³/hr.

Amount Removed in-situ (m³) :

The data have indicated that 127 m³ of in-situ material has been removed during the demonstration. From this total volume, 64% was mill-scale while 36% was non-mill-scale type sediment.

Removal Cost :

The total cost of this demonstration was 324,000 \$(US), leading to a unit cost of 2,551 \$(US)/m³. This high cost was related to special demonstration requirements and to health & safety requirements related to dredging in highly contaminated sediment.

Mobilization Time (days) : 7

The portable Mud-Cat MC-915 ENV suction dredge, manufactured by Ellicott Machine Corporation of Baltimore, Maryland was selected as the preferred dredging technology for the demonstration. The following modifications were incorporated into the dredge :

- 1) Auger : hydraulic forward tilt and manual transverse tilt and dual convergence variable pitch and multi-flight auger,
- 2) Removable vibrating front shroud,
- 3) Special truss boom assembly including suction hose, modified to allow pivoting for 15 ft digging depth,

A 20 cm pipeline consisting of flexible floating section and a rigid land based section was installed over a distance of 1,500 m from the dredge to the treatment facility. A booster pump was necessary as the combination of head and friction loss in the approximately 1,500 m length of pipe was too large (240 ft) for the centrifugal pump on the dredge to handle alone. The booster pump was located approximately 700 m downstream from the dredge. A silt curtain was also placed in order to confine the work area.

Demobilization Time (days) : not available

In order to assess the project and the dredge performance, an instrumentation/data logging package was added to the dredge. Analog displays provided the dredge operator with real-time indicators of dredging performance. The

Normrock Industries Inc., Amphibex

20-Jan-98

instrumentation included :

- 1) one nucleonic densitometer
- 2) one electromagnetic flowmeter
- 3) one dredge head vibration sensor
- 4) one dredge head turbidity sensor
- 5) analog displays for above-noted sensors
- 6) one datalogger with 4 input channels

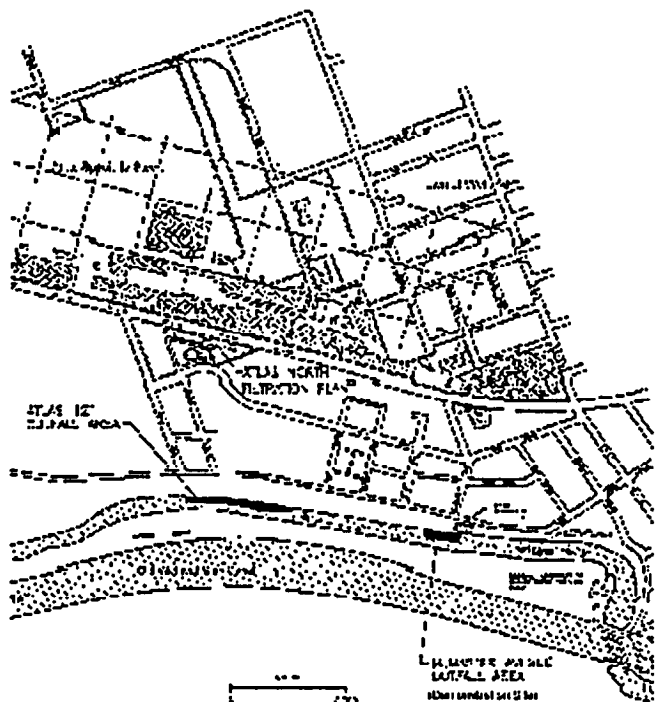

Penta-Ocean, Pneumatic Type Sand Pressurized Feeding Ship (GOSEI GO)

20-Jan-98

TechID: 290

Technology Type: Pneumatic

System Works With: Debris, Water Depth 2-10m

Development Stage: Commercial

Country Of Origin: Japan

Description:

Without adding water to the excavated soft soil, a large amount of soil can continuously be transported through the pipe to the reclamation site by compressed air. Since the transported sand is of a high density, almost no excess water is produced from the reclaimed land.

Limitations: Dredged sand can be transported to maximum distance of 3000 meters.

Type of Power:

Government Funding:

Environmental Concerns:

Health & Safety Plan Available:

Regulatory Approvals

Setup/Feed: Mobilization (days):
Removal Rate Average (m³/hr): 800

Demobilization (days):

Cost: Capital Cost (US\$):
Unit Cost (US\$/m³): -

Average Cost (US\$/m³):

Developers:

Penta-Ocean Construction Co. Ltd
Corporate Technical Division
Tokyo, 160,
Japan 160-10
Notes

Contact: Technical Dept.,
Phone: 81353817549 Ext:
Fax: (035) 381-7540
Email:

Literature References:

Technology Type: Mechanical

Buckets rotating type

System Works With:

Dredging depth 2m to 24m. Current up to 0.5 m/sec.

Development Stage: Commercial

Country Of Origin: Japan

Description:

To rotate and advance simultaneously the dredging drum has a number of bucket chambers formed by sequentially projected sliding blades, which penetrate into the sediments to cut and lift up gently along the scraper into the dredge head.

Distinctive features of "SWAN No.3" :

- (1) High density dredging of up to 80% solid concentration.
- (2) Low turbidity dredging as the sediments are gently taken into the dredge head.
- (3) Flat-finish after the sediments are cut and lifted up along the scraper.
- (4) Thin layer dredging from the surface of sediments.
- (5) High accuracy up to a few centimeters order at the real-time positioning of dredge head by using GPS (Global Positioning Systems).
- (6) Long distance discharge by pneumatic transportation is applicable by using air-compressors.

Limitations: Applicable soil; Silt and clay.

Type of Power:

Government Funding:

Environmental Concerns:

Health & Safety Plan Available:

Regulatory Approvals

Setup/Feed: Mobilization (days):

Demobilization (days):

Removal Rate Average (m³/hr): 150

Cost: Capital Cost (US\$):

Unit Cost (US\$/m³): -

Average Cost (US\$/m³): \$25.00

Indicates direct dredging expenses only.

Developers:

Penta-Ocean Construction Co. Ltd

Corporate Technical Division

Tokyo, 160,

Japan 160-10

Notes

Contact: Technical Dept.,

Phone: 81353817549

Ext:

Fax: (035) 381-7540

Email:

Vendors:

Penta-Ocean Construction Co. Ltd

Corporate Technical Division

Tokyo, 160,

Japan 160-10

Notes

Contact: Technical Dept.,

Phone: 81353817549

Ext:

Fax: (035) 381-7540

Email:

Literature References:

Author: Teramoto, A., Ikeda, S.

Title: The Development of Clean and Dense Dredging System, 1991

Journal: Meeting on Management of Bottom Sediments Containing Toxic

Date:

Penta-Ocean, SWAN Method

20-Jan-98

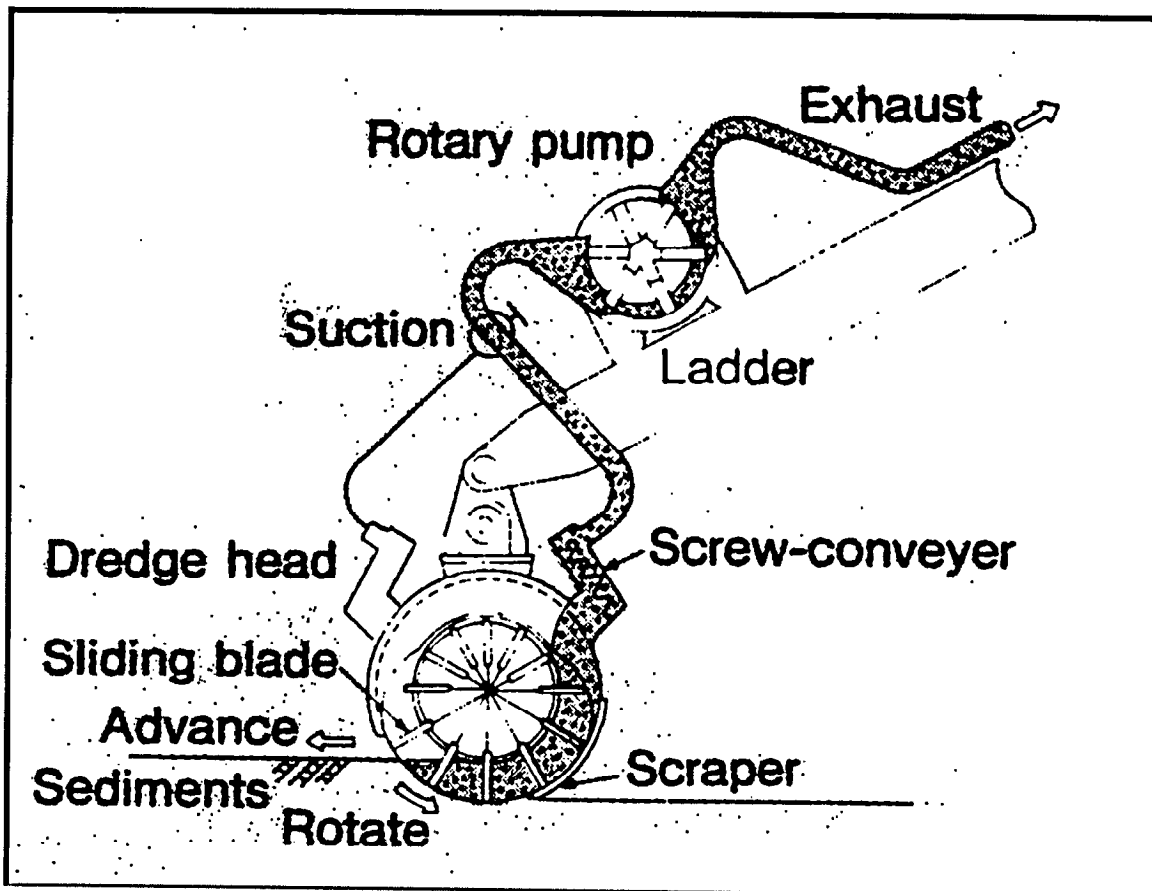
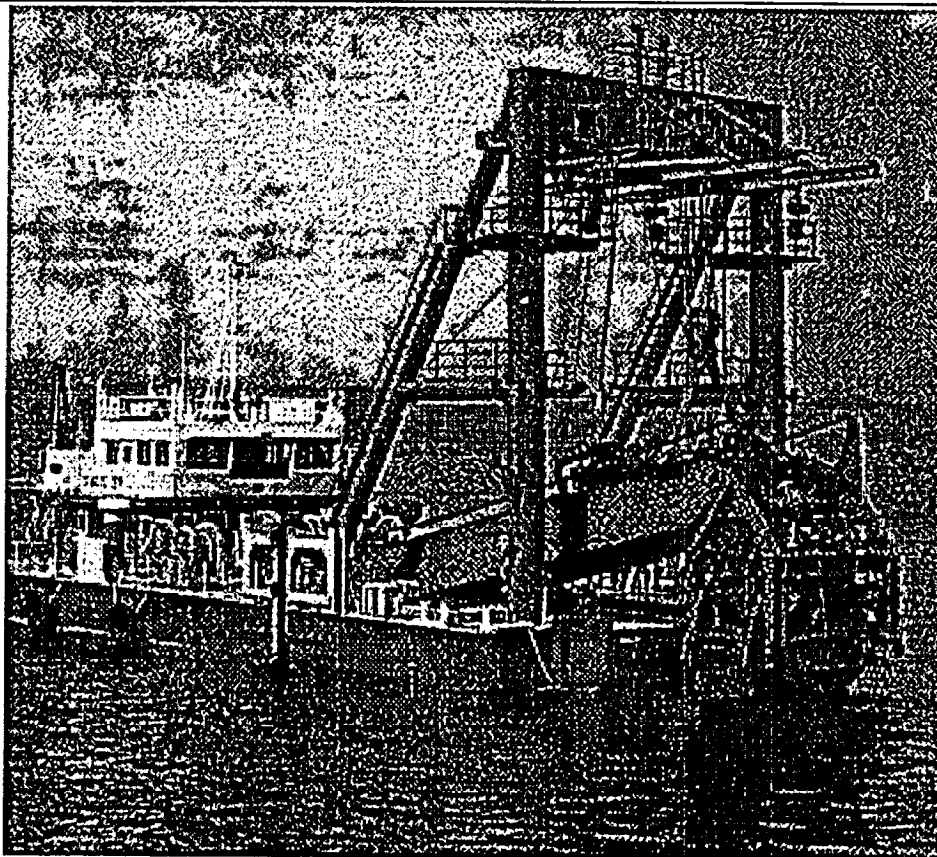

Penta-Ocean, SWAN Method

20-Jan-98

Project: Mooring Basin Dredging Work (-7.0m) at Ishinomaki

Year 95

Location: Miyaki - Ken, Japan

Commercial

Client/Funding Agency	Contact	Phone
Miyagi Prefecture		

Not Monitored

Removal Rate(m³/hr): Amount Removed In-Situ (m³):

Removal Cost(US\$):

Mobilization (days): Demobilization (days):

Site Conditions:

Contaminants Present: No harmful substance. Dredging-Pneumatic transportation-Reclamation Discharge length 2.00m. Dredging depth: 7.0 m. Sediment thickness: 0.2 m to 0.5 m. Type of sediment: silt. Sand 24.7%. Silt 60.1%. Clay 15.2 %.

Water Quality: n/a

Turbidity: n/a

Total Suspended Solids: n/a

Percent Solids: n/a

Site Containment Used? No Yes

Exceed Set Standards?

Description:

Project: '94 Gamagori Portand Harbour Environmental...

Year 94

Location: Aichi - Ken

Commercial

Client/Funding Agency	Contact	Phone
Aichi Prefecture		

Not Monitored

Removal Rate(m³/hr): Amount Removed In-Situ (m³):

Removal Cost(US\$):

Mobilization (days): Demobilization (days):

Site Conditions:

Contaminants Present: No harmful substance. dredging-Barge-direct dumping. Transporting distance 13 km. Dredging depth: 10 m. Sediment thickness: 0.5 m. Type of sediment: silt organic. Moisture content: 20%.

Water Quality: n/a

Turbidity: n/a

Total Suspended Solids: n/a

Percent Solids: n/a

Site Containment Used? No Yes

Exceed Set Standards?

Description:

Project: Nakaumi clean-up Dredging

Year 93

Location: Shimano - Ken, Japan

Commercial

Client/Funding Agency	Contact	Phone
Chugoku Regional Construction Bureau, Ministry ...		

Not Monitored

Removal Rate(m³/hr): Amount Removed In-Situ (m³):

Removal Cost(US\$):

Mobilization (days): Demobilization (days):

Site Conditions:

Contaminants Present: No harmful substance. Dredging-pneumatic transportation (Pipe Line)-reclamation. Discharge length 1,000 m. dredging Depth: 4.7 m to 5.0 m. Sediment thickness: 0.7 m. Type of sediment: Silt sludge. Moisture content 15% to 54%. Sand 6.1%. Silt 39%. Clay 54%.

Water Quality: n/a

Penta-Ocean, SWAN Method

20-Jan-98

Turbidity: n/a
 Total Suspended Solids: n/a
 Percent Solids: n/a
 Site Containment Used? No Yes
 Exceed Set Standards?

Description:

Project: New Onoda Power Plant Anchorage Area Dredging

Year 91

Location: Tjamaguchi-Ken, Japan

Commercial

Client/Funding Agency	Contact	Phone
The Chugoka Electric Power Co. Inc.		

Not Monitored

Removal Rate(m³/hr): Amount Removed In-Situ (m³):

Removal Cost(US\$):

Mobilization (days): Demobilization (days):

Site Conditions:

Contaminants Present: No harmful substance. Description: Dredging-Barge-Reclaimer. Discharge length: 100 m. Transporting distance: 47 km. Dredging Depth: 7.5 m to 11.5 m. Sediment thickness: 1.0 m to 2.0 m. Type of sediment: Sand 2%, silt 68 %, clay 30%. Moisture content: 18% to 25%

Water Quality: n/a

Turbidity: n/a

Total Suspended Solids: n/a

Percent Solids: n/a

Site Containment Used? No Yes

Exceed Set Standards?

Description:

Pneuma s.r.l. / IME Ltd., Underwater Dredging Pump

20-Jan-98

TechID: 308

Technology Type: Pneumatic

No rotating cutter. Compressed air created delta relative to an ambient seawater pressure and entrains material.

System Works With: Debris, Strong Currents, Water Depth 2-10m, Limited Shore Access

Development Stage: Full Scale Demo

Country Of Origin: Italy

Description:

The system consists of a hydrostatic pump, capable of high flow rate suction of slurry, in subsea and underwater environments. The pump can handle materials having a high solids content either by reflowing them over long distances to disposal sites or by transporting them to containers.

The system may also incorporate a modular remote head enabling access to confined areas around a platform structural base. The system is also used in the mining industry and for pipeline burial and trenching operations.

Limitations: Water depth currently 20 m, although greater depth can be achieved. Particle size limited to 50 mm diameter.

Type of Power: Compressors operate by any type of motor.

Government Funding:

Environmental Concerns: Reduced turbidity due to the absence of rotating cutter.

Health & Safety Plan Available:

Regulatory Approvals: None applied for to date.

Setup/Feed: Mobilization (days):

Demobilization (days):

Removal Rate Average (m³/hr):

Cost: Capital Cost (US\$):

Unit Cost (US\$/m³):

—

Average Cost (US\$/m³):

Cost according to depth and capacity. Extremely dependent on individual circumstances/requirements.

Developers:

Ian Murray Engineering Ltd.
87 Waterloo Quay
Aberdeen, Grampian
Scotland AB2 1DE
Notes

Contact: Punt, Alistar
Phone: 4401224596464 **Ext:**
Fax: 4401224574888
Email:

Ian Murray Engineering Ltd.
87 Waterloo Quay
Aberdeen, Grampian
Scotland AB2 1DE
Notes

Contact: Murray, Ian
Phone: 4401224596464 **Ext:**
Fax: 4401224574888
Email:

Vendors:

Pneuma s.r.l.
Via Di Varlugo, 59a
Firenze,
Italy 50136-
Notes

Contact: Faldi, G.
Phone: (05) 569-0437 **Ext:**
Fax: (055) 650-3989
Email:

Ian Murray Engineering Ltd.
87 Waterloo Quay
Aberdeen, Grampian
Scotland AB2 1DE
Notes

Contact: Punt, Alistar
Phone: 4401224596464 **Ext:**
Fax: 4401224574888
Email:

Pneuma s.r.l. / IME Ltd., Underwater Dredging Pump

20-Jan-98

Ian Murray Engineering Ltd.

87 Waterloo Quay
Aberdeen, Grampian
Scotland AB2 1DE
Notes

Contact: Murray, Ian

Phone: 4401224596464 Ext:
Fax: 4401224574888
Email:

Literature References:

Author: Murray, I.J., Faldi, G., Baldoni, A.
Title: Environmentally Safe Removal of Drill Cuttings
Journal: Oil and Gas in a Wider Europe : 4th E.U. Symposium, Berlin 1992.

Date:

Author: (Editorial)
Title: An Environmentally Friendly Seabed Clearance System
Journal: Oil and Gas Technology

Date: Jul 1994

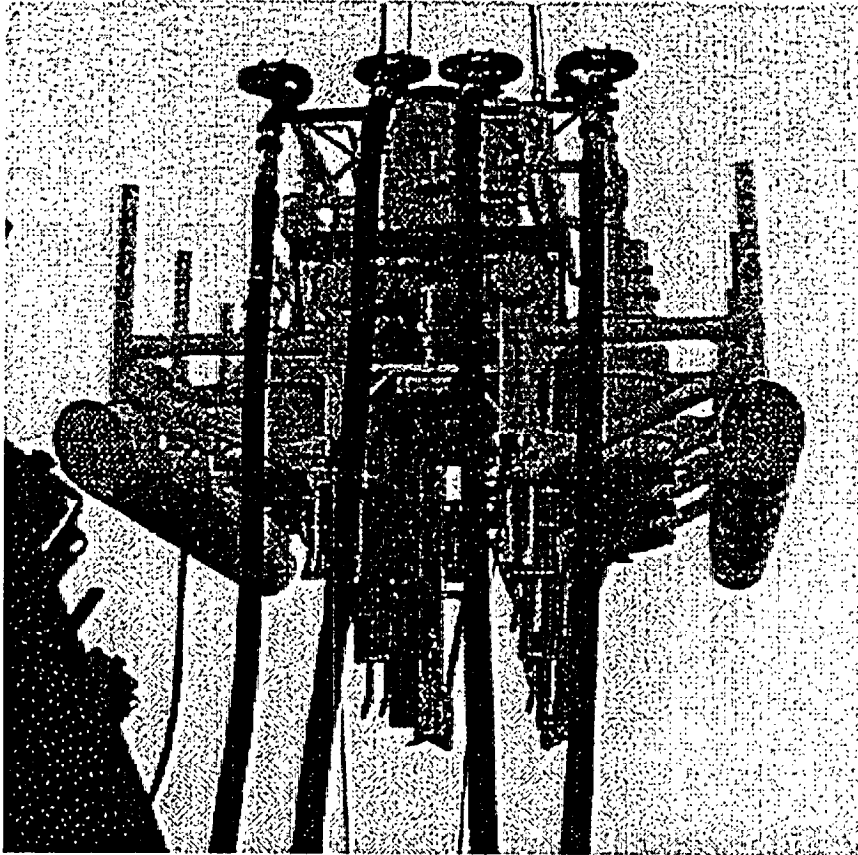

Pneuma s.r.l. / IME Ltd., Underwater Dredging Pump

20-Jan-98

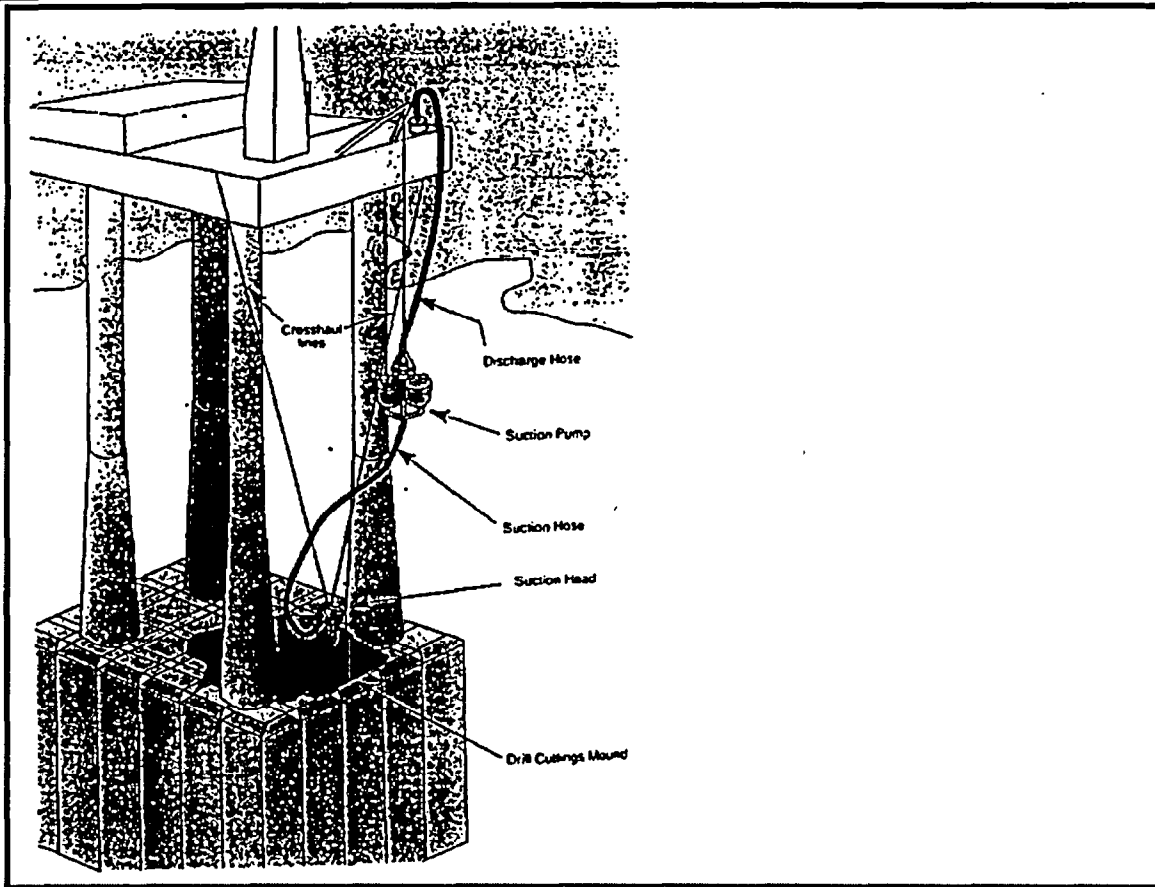

Pneuma, Hydraulic Dredge

20-Jan-98

TechID: 303

Technology Type: Pneumatic

System Works With: Debris, Strong Currents, Water Depth 2-10m, Limited Shore Access

Development Stage: Commercial

Country Of Origin: Italy

Description:

The Pneuma Dredging system is an innovative technology using compressed air with alternating pistons in a three-cylinder chamber. The pistons operate in sequence providing continuous output at up to 60% solids concentration depending on sediment conditions and type. In deep water (200m), the hydrostatic pressure at dredging depth reduces energy requirements. The system is equally effective in very shallow waters with numerous assembly options and methods of use, on pontoons, barges, in-tow or using a "dipping" method. When used in-tow, various intake configurations (e.g. plows) are available to adjust to conditions. The absence of rotating cutters provides for excellent environmental results and very low maintenance requirements.

Limitations: Very hard bottom material; for example boulder field, compacted clay.

Type of Power: Compressor - Powered by diesel or gasoline.

Government Funding: Great Lakes Cleanup Fund, DESRT, SITE, Superfund, ETP

Environmental Concerns: None - Little turbidity.

Health & Safety Plan Available:

Regulatory Approvals

Setup/Feed: Mobilization (days):

Demobilization (days):

Removal Rate Average (m³/hr): 25

Cost:

Capital Cost (US\$):

Unit Cost (US\$/m³): \$5.00 – \$50.00

Average Cost (US\$/m³): \$28.00

Terra Firma Technologies Inc. : Capital cost \$50,000 to \$300,000 depending on size/capacity.
A large range of capacities are available from 40 m³/hr, to 2,000 m³/hr.
Voyageurs Marine Construction Co. Ltd.: Capital cost: \$150,000

	Avg.	Min.	Max.
Voyageurs Marine Construction Co. Ltd.:	\$30.00	\$12.00	
Terra Firma Tech. Inc.:	\$16.00	\$5.00	\$50.00
\$28.00			
Granite Construction Company			\$1.40

Developers:

Pneuma s.r.l

Via Di Varlugo, 59a

Firenze,

Italy

50136-

Notes

Contact: Faldi, G.

Phone: (05) 569-0437

Ext:

Fax: (055) 650-3989

Email:

Vendors:

Aquatics Unlimited

827 Arnold Drive, Suite 80, Bay 11

Martinez, CA

USA

94553-

Notes

Contact: McNabb, Thomas

Phone: (510) 370-9175

Ext:

Fax: (510) 370-9179

Email:

Voyageurs Marine Construction Co. Ltd.

743 Harwood Blvd.

Dorion, PQ

Canada

J7V8P2

Notes

Contact: Kocsis, Alex

Phone: (514) 455-5677

Ext:

Fax: (514) 455-5678

Email:

Pneuma, Hydraulic Dredge

20-Jan-98

Terra Firma Technologies, Inc.

2027 Richmond St.

Arva, Ontario

Canada

NOMICO

Notes

Contact: Bos, Art

Phone: (519) 850-0011

Ext:

Fax: (519) 850-0012

Email:

Literature References:

Author: Faldi, G., Bualo, Grancini

Title: Reclamation and Environmental Control of Pollution - Affected Water Courses by dredging through the Pneuma System

Journal: Environmental Technologies Meeting (Nov. 25-26).

Date:

Author: Faldi, G.

Title: Italian Dredging System Eliminates Secondary Pollution

Journal: Dredging and Port Construction

Date: Nov 1989

Author: Faldi, G.

Title: A Transportable Pneuma Dredger for Polluted Bottoms

Journal: The Dock & Harbour Authority

Date: Sep 1990

Author: Consultants J. Berube

Title: Environmental Precaution, Dredging, Re-suspension

Journal:

Date: Sep 1994

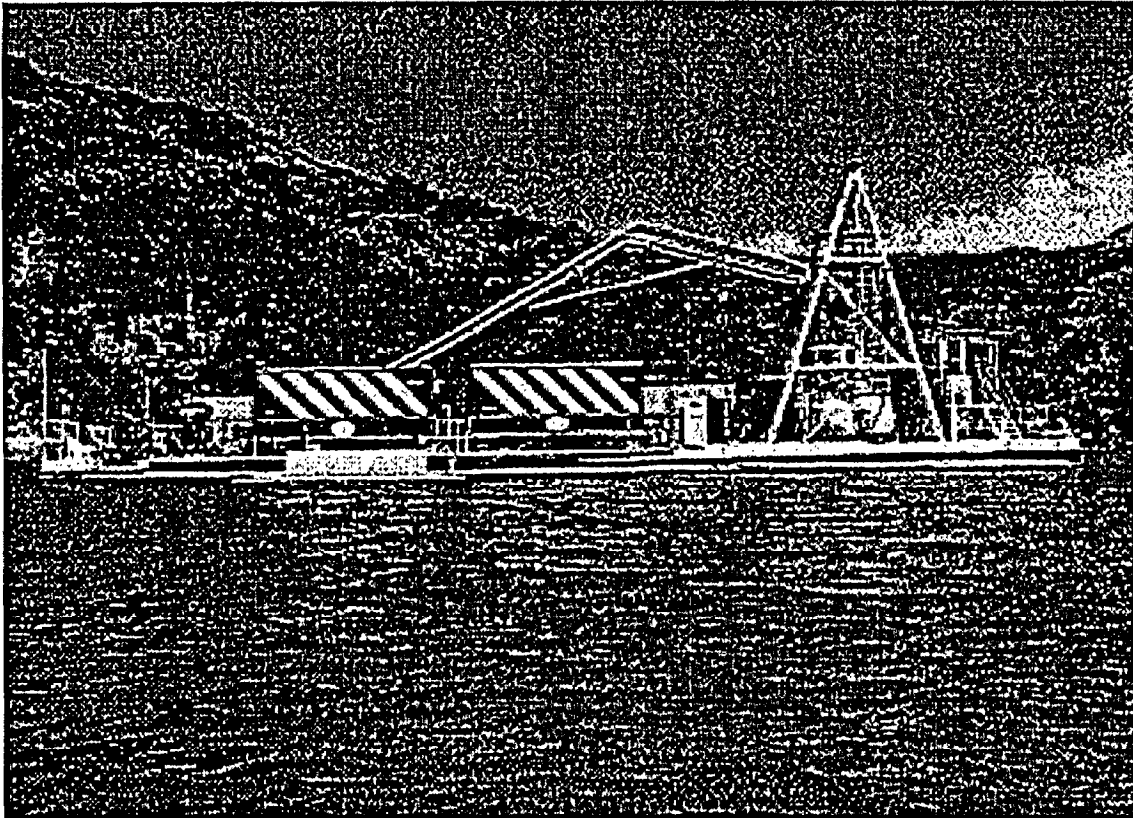

Pneuma, Hydraulic Dredge

20-Jan-98

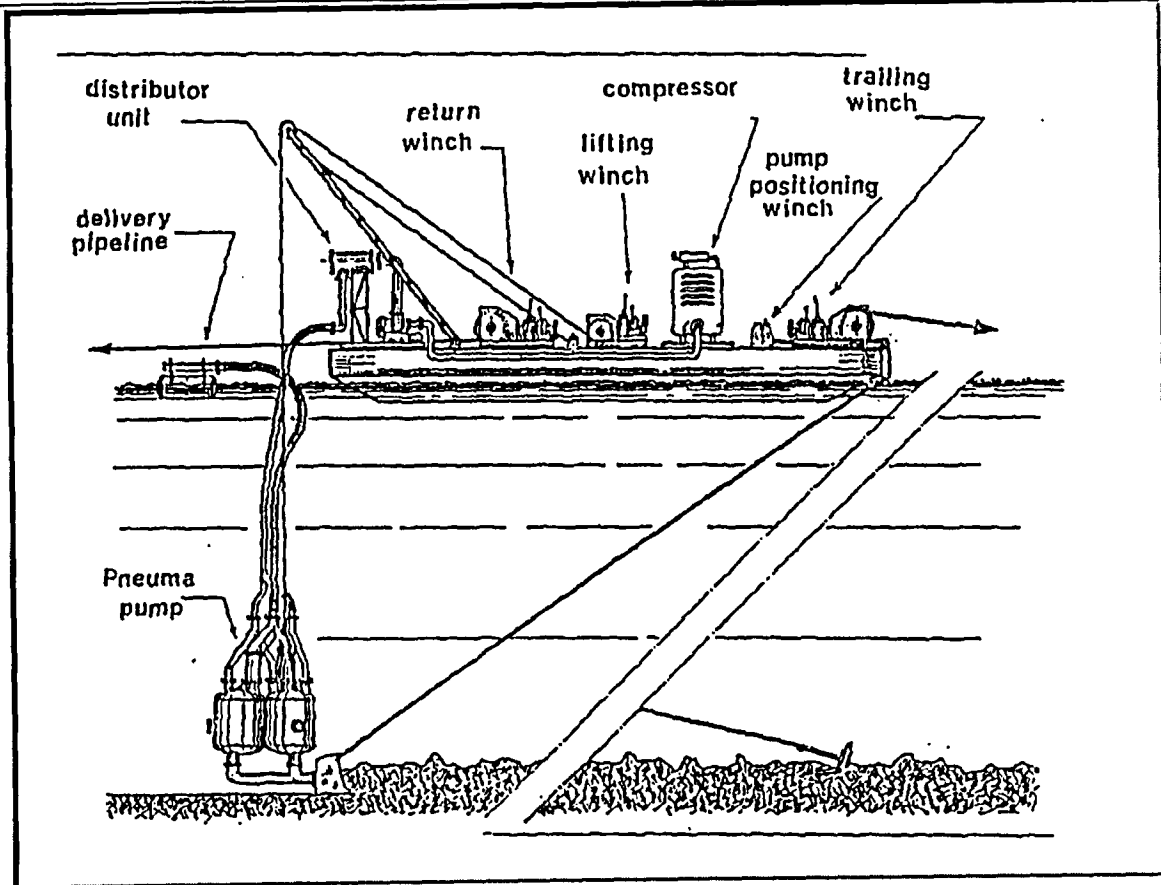

Pneuma, Hydraulic Dredge

20-Jan-98

Project: Collingwood Harbour Dredging Project

Year 93

Location: Collingwood, Ontario, Canada

Commercial

Client/Funding Agency	Contact	Phone
Transport Canada Remediation Technologies Program/Great Lakes Cleanup Fund	Ian Orchard	(416) 739-5874

* Monitored * Auditor: Ian Orchard (Environment Canada) Phone: (416) 739-5874

Removal Rate(m³/hr): 45 Amount Removed In-Situ (m³): 3000

Removal Cost(US\$): \$136,000.00

Mobilization (days): 3 Demobilization (days): 1

Site Conditions: Collingwood Harbour is relatively shallow with a maximum depth of 6.4 m (at datum) in the dredged portion of the 244 m turning basin. The harbour encompasses roughly 0.8 km² in area and has an approximate volume of 2.7 x 10⁴ km³. The entrance to the harbour is formed by two piers extending from shore. The breakwater pier on the western side of the harbour extends eastward 0.22 km. The eastern extension of the harbour pier runs in a northwesterly direction 1.02 km, resulting in a harbour entrance gap of 420 m.

The harbour is subject to prevailing winds and waves of long fetch originating from north to northeasterly directions. The shape and orientation of Collingwood Harbour are such that its mixing regime is affected by seiche effects and there is limited exchange with Nottawasaga Bay waters.

Following the contaminated sediment removal demonstration/cleanup of 1992 performed by the Remediation Technologies Program (RTP) and its partners, Transport Canada, the Collingwood Harbour Remedial Action Plan (RAP) team and the RTP decided to procede with the removal of additional contaminated sediment outside of CCSL's boat slips. This decision was based on the assessment of the results from a sediment sampling survey performed in April 1992, which indicated that an area of 9,930 m² required removal of sediment due to levels of lead exceeding the Ontario Ministry of the Environment and Energy severe effect level guideline of 250 ppm, and showing toxicity to some benthic invertebrates. Earlier studies performed by the Remedial Action Plan had indicated that the contaminated silt was overlaying a clean clay layer on top of bedrock, meaning that the clay layer was from the pre-industrial activity era. It was then decided that removal of the silt (thickness varying from 0.2 to 0.5 m) only was necessary to remediate the area. Figure 1 shows the extent of the study area.

Contaminants Present:	Contaminants	Max. Concentration (ug/g, dry)	LEL (ug/g)	SEL (ug/g)
	Chromium	31	26	110
	Copper	61	16	110
	Lead	150	31	250
	Zinc	180	120	820

The LEL and the SEL are both guidelines established by the Ontario Ministry of the Environment & Energy for the protection and management of aquatic sediment quality in Ontario. The LEL represents the lowest concentration where a contaminant will have an effect on benthic organisms, while the SEL is the concentration where contaminants will have a detrimental effect to the majority of benthic organisms.

Water Quality: Although a decrease in phosphorus levels within the harbour has occurred since nutrient controls were introduced in the early 1970's, algal blooms still occur during the warm summer months. However, these algal blooms do not impact present use of the harbour in any way, other than by diminishing aesthetic value. Results of the 1980 and 1983 studies show that total phosphorus levels in Collingwood Harbour ranged from a mean of 153 ug/L at stn. 22 (Aug.30-Sept.1, 1983), located between the STP discharge and the shipyards, to 11 ug/L at the harbour outlet. Although phosphorus levels have decreased since 1974, results of surveys in 1980, 1983 and 1986 exceeded the Provincial Water Quality Objectives (PWQO) of 20 ug/L, recommended to avoid nuisance algal growth. Expansion of the STP and the introduction of a secondary treatment facility has resulted in significant improvements in effluent quality. By 1987, effluent quality no longer exceeded the PWQO effluent requirement of 1 mg/l specified in the Great Lakes Water Quality Agreement (1983).

Studies from April to November 1989, 1990 and 1991 reveal that average phosphorus concentrations for most of the harbour meet or are below the objective, but phosphorus concentrations did exceed the objective in the more stagnant areas of the harbour for periods of days to weeks. The overall values for phosphorus concentration in the harbour was less than 0.02 mg/l during the 1990 study period.

Black Ash Creek and the canals may also contribute to a small degree, to elevated phosphorus levels. Although phosphorus concentrations in Black Ash Creek are typically less than concentrations in the canals, the flows in Black Ash Creek are substantially greater leading to an overall greater loading from the creek. Excessive algal growth occurs at the outfall of Black Ash Creek because of the high levels of phosphorus in the runoff, which may be attributable to the fact that Balck Ash Creek drains agricultural areas. Phosphorus-containing fertilizers, used in agriculture, commercial and residential properties, may be contaminating the harbour through the creek as a result of drainage.

The relatively high turbidity of water in Collingwood Harbour is typical of harbours in the Great Lakes, and

Pneuma, Hydraulic Dredge

20-Jan-98

can be traced to high concentrations of suspended algae and fine particulate matter. Turbidity in Collingwood Harbour and Nottawasaga Bay tends to decline with progression from the inner harbour to the bay. Average turbidity levels at most stations tended to be higher in 1986 than in earlier years, with maximum averages of up to 18.6 FTU at most turbid station. Background turbidity levels in Nottawasaga Bay have been given as 1.0 FTU or less (Ross and Chatterjee, 1978), although nearshore bay stations sampled in this study showed somewhat higher turbidities due to the effects of Collingwood Harbour and other shoreline influences. Some of this increase in turbidity may be attributed to harbour dredging in the fall of 1986, as well as to construction activities and associated erosion in shoreline areas around the harbour. Turbidity does not originate from the STP effluent, as the effluent is of lower average turbidity than most harbour stations. Black Ash Creek and Oak Street Canal showed high average turbidity levels in 1986, indicating that these streams may contribute significantly to the turbidity of the harbour. Through studies conducted in 1974, 1980, 1983 and 1986, MOE collected a limited number of samples for bacteriological enumeration. Data from the 1980 study (July & Aug.) indicated levels of fecal coliform bacteria above the PWQO for swimming and bathing of 100 counts/100 ml at number of sites within Collingwood Harbour.

Data from the 1983 study (June & Aug.) indicated generally improved conditions with bacteria levels below the PWQO at most sites. Results from surveys conducted in 1989, 1990 and 1991 indicated that all sites sampled met the PWQO for swimming and bathing.

Turbidity: The water quality monitoring program included sampling runs performed prior, during and after the demonstration/cleanup project. The pre-demonstration sampling runs were performed once a day on October 26 and 27, and on November 3, 1992. During the demonstration/cleanup project, in-field water quality measurements were performed 2 to 8 times a day (depending on removal activities), while samples to be submitted to the laboratory were collected once or twice a day (also depending on removal activities).

A 6.2 L Kemmerer sampler composed of transparent polyvinyl chloride and acrylic plastic with silicone rubber seals was used for collection of water samples. Samples were collected one meter below the water surface (Station # followed by A) and one meter above the sediment surface (Station # followed by B). One sampler load was used to fill all the bottles.

In-field measurements consisted of turbidity, conductivity, temperature and pH readings. Turbidity measurements were performed using a Monitek nephelometer, conductivity measurements were performed using a conductivity meter. QA/QC on in-field measurements was performed by taking random duplicate samples for turbidity.

Turbidity measured at 25 m from the pump averaged approximately 6 NTU, with a maximum value recorded of 20 NTU on surface, and approximately 8 NTU, with a maximum turbidity level recorded of 36 NTU at 1 m from the bottom. Ambient levels of turbidity were approximately 5 NTU, on both surface and bottom. From these turbidity results, it could therefore easily be seen that very little disturbance was caused on surface waters, and only minimal disturbance could be felt in the bottom waters.

Total Suspended Solids: The results for TSS at 25 m from the pump have indicated that the average concentration was approximately 5 mg/L on surface, and 10 mg/L at 1 m from the bottom. The maximum level reached were 10 mg/L on surface and 17 mg/L at the bottom. The ambient total suspended solids concentration averaged approximately 5 mg/L, both on surface and bottom.

Percent Solids: It is estimated that the average velocity of the slurry in the discharge pipeline is 2.5 m/s. The inside diameter of the discharge pipeline measures 144 mm which represents an hourly flow of slurry through the pipeline of approximately 146.6 m³/hr. With a production rate of 45 m³/hr, the percentage of solids in the dredge slurry pumped by the Pneuma Pump is determined to be approximately 30.7 % (i.e. 45 m³/hr , 146.6 m³/hr).

Site Containment Used? No Yes

Exceed Set Standards? The standards used for this commercial application of the Pneuma pump were the same as the ones used for the demonstration :

Sediment Removal Phase :

- 1) Turbidity: Turbidity beyond a distance of 25 m of the actual removal location shall not exceed ambient levels by more than 30%.
- 2) Suspended Solids: Beyond a 25 m distance of the actual removal location, suspended solids shall not exceed ambient levels by more than 25 mg/l.
- 3) Total Organic Carbon: Total Organic Carbon (TOC) content should be within the range of 0.4-27 mg/l in surface water beyond 25 m of the removal operation. TOC shall not exceed background levels by more than 30% when background concentrations are greater than 27 mg/l.
- 4) No Overflow or Leaks: A minimum freeboard of 1 m must be maintained in the hopper of holding facility for the excavated sediment. The holding facility must be sealed for transport to the pre-treatment/disposal site.
- 5) Removal Efficiency: The solids to liquids ratio in the excavated material should be at least 30% by volume.
- 6) Effluent Quality: Maximization of solids removal is paramount. Solids suspended in the slurry mixture must be removed by some means, either mechanical or chemical (flocculation). If the extracted material is fine grained, provision should be made to treat the effluent.
- 7) Production Rate: The production rate of the sediment removal equipment should be adjusted to show sufficient settling time for effluent to meet the Provincial Water Quality Objectives (PWQOs). Therefore, the

Pneuma, Hydraulic Dredge

20-Jan-98

feed rate of the excavated material into the holding facility for transport to the pre-treatment disposal area should be adjusted accordingly.

Transport Phase:

- 1) No Overflow or Leaks: No overflow or leaks of excavated material shall be allowed during transport to the disposal or pre-treatment area. Use of pipelines or other fully closed transport mediums is encouraged.
- 2) Transport Rate: The rate of material being transported must be adjusted to meet the handling capacity of the pre-treatment or disposal facility.
- 3) Contact: No contact is permissible between the contaminated sediment and human, bird and aquatic life.

Pre-Treatment Phase :

- 1) Effluent Quality: Effluent quality of the supernatant water and effluent from the pre-treatment process should meet applicable federal and provincial standards and guidelines.
- 2) Waste Handling: All wastes from the pre-treatment process should be handled and disposed of in accordance with appropriate regulatory requirements.

Those standards were not exceeded during the project.

Description: In November 1993, the Pneuma Pump #150/30 went up against competition and won the bid to remove additional sediment from Collingwood Harbour. This was the first commercial application of the Pneuma system since the demonstration of November 1992.

Removal Rate :

The equipment used for the demonstration was a Pneuma Pump #150/30 with a maximum capacity of 175 m³/hr of solids. The maximum reflow distance was 1500-2000 m through a 150 mm diameter reflow pipeline. The Pneuma pump #150/30 was in a trailing system arrangement on a flat deck barge which is capable of operating in shallow water (1.8 - 2.7 m). The quantity of air needed for the dredging and for the vacuum system to be compressed at 3/5 atm is 32 m³/min. The available power was approximately 300 HP. The estimated fuel consumption of the compressor will be 60 L/hr at the maximum operating pressure of 7 atm.

The actual operations started in late afternoon, on 24 November and ended on 08 December 1993. Since 66 hours were required to removed approximately 3,000 m³ of sediment, the pumping rate could be estimated to be 45 m³/hr, with an average percentage of solids in the slurry of 30%, leading to a volume of dry solids removed from the bottom of the harbour of 900 m³. Fifty-three hours were devoted to downtime. Downtime represents non-dredging time including equipment set-up and preparation, mechanical breakdowns and repairs, relocation of dredge, moving cables, etc.

Amount Removed in-situ (m³) :

In total, approximately 3,000 m³ of contaminated silt was pumped to the confined disposal facility located 0.8 km away from the removal site through a 15 cm reflow pipeline. Post-dredging soundings have indicated that sediment was removed to an average depth of approximately 0.3 m.

Removal Cost :

The total cost of this project was 136,000 \$(US) (unit cost 45.36 \$(US)/m³).
lowest proposal received.

Mobilization Time (days) : 3

Mobilization started on 22 November and ended on 24 November 1993. The following is a list of equipment brought on site by the contractor :

- Pneuma Pump unit 150/30, including pump body, distributor, vertical inlet shovels, hoses, lowering and raising frame, etc.
- Flat barge (dimensions 13.7 m x 8.5 m x 1.5 m) equipped with steel spuds, anchors, 4 winches, generator and lights
- Crawler Crane (25 ton)
- Air compressor (1400 cfm)
- Workboat (185 HP)
- Small boat (4 m)
- Office Trailer
- 150 mm O.D. PVC discharge pipeline (1,000 metres length).

Demobilization Time (days) : 1

Demobilization and site cleanup occurred on 09 December 1993.

Regulatory Approvals :

Federal Government:

Canadian Coast Guard, Department of Transport:

Approval to Dredge in a Navigable Waterway under Section 5(2) of the Navigable Waters Protection Act, RSC 1985, Chapter N-22.

Department of Fisheries and Oceans:

Approval under Section 33 of the Fisheries Act.

Federal Environmental Assessment and Review Office:
Initial Screening of the proposal undertaken in keeping with the requirements of EARP.

Affected Property Owners
- Collingwood Terminals Limited
- Collingwood Yacht Club
- CN

Monitoring :
Water Quality Monitoring was performed by the Remediation Technologies Program of Environment Canada

Bibliography:
Collingwood Harbour Remedial Action Plan Team. 1989. Environmental Conditions & Problem Definition. Environment Ontario & Environment Canada. March.

----- 1991. Making Choices: Discussion Paper on Remedial Options. Environment Ontario & Environment Canada. March.

----- 1992. A Strategy for Restoring the Collingwood Harbour Ecosystem and Delisting Collingwood Harbour as an Area of Concern. Draft. Environment Ontario and Environment Canada. April.

Pelletier, Jean-Pierre. 1994. Hamilton Harbour Contaminated Sediment Removal Demonstration: Report on the Water Quality Monitoring Program. Restoration Techniques Development Program. Environmental Protection Branch-Ontario Region. Environment Canada. January.

Persaud, D., R. Jaagumagi and A. Hayton. 1992. Guidelines for the Protection and Management of Aquatic Sediment Quality in Ontario. Water Resources Branch, Ontario Ministry of the Environment and Energy. June.

Public Works Canada - Ontario Region. 1993. Contaminated Sediment Removal Technology Demonstration, Collingwood West Dry Dock, Collingwood, Ontario. Project Field Report. Architectural and Environmental Services. Project No. 649678. June.

Public Works Canada. 1991. Investigation of Hard Bottom in the Proposed Demonstration Areas in Collingwood Harbour. Architecture and Engineering, Division. Toronto. August.

Ross, D.I., R.M. Chatterjee. 1977. Water Quality Assessment of some Ontario Embayments on Lake Huron including Goderich, Port Elgin, Southampton, Tobermory, Owen Sound, Collingwood and Parry Sound. Ministry of the Environment. 1977.

Collingwood Harbour (1993)

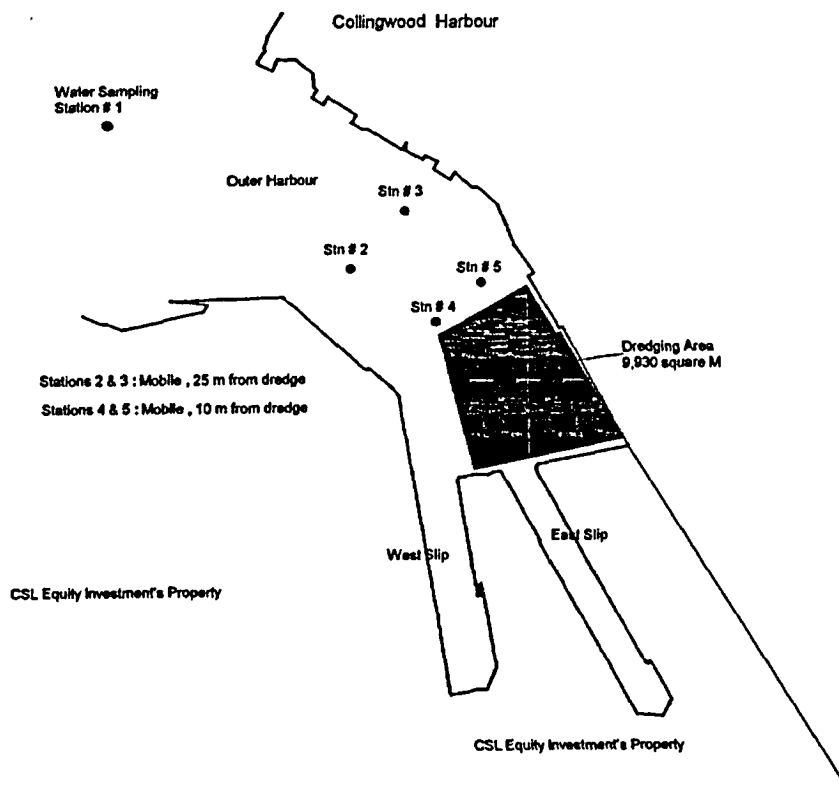
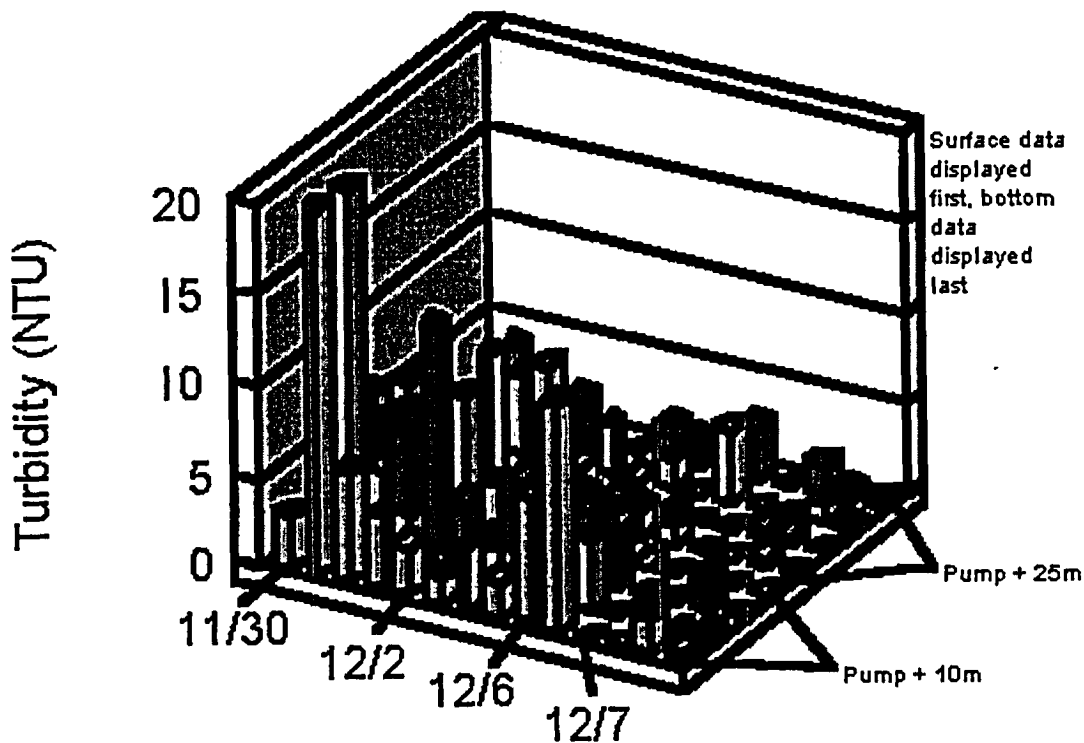

Pneuma, Hydraulic Dredge

20-Jan-98

Location: Gibraltar Lake, Santa Barbara, California, USA

Full Scale Demo

Client/Funding Agency	Contact	Phone
US EPA - Clean Lakes Program City of Santa Barbara	Mayor David T. Shiffman	-

Not Monitored

Removal Rate(m³/hr): 570 Amount Removed In-Situ (m³): 16720000

Removal Cost(US\$): \$2,255,000.00

Mobilization (days): Demobilization (days):

Site Conditions: Gibraltar Lake lies in the boundaries of the City of Santa Barbara. It is located in rugged terrain, with steep slopes surrounding it. The top of the Gibraltar dam, located at the mouth of the Ynez river, stands 1400 feet in elevation. The Gibraltar watershed comprises 140,400 acres of land, and has a maximum elevation of 6600 feet.

Geologic formations in the area consist of thick accumulation of marine sedimentary shale, siltstone, sandstone, and conglomerate of Cretaceous to upper Miocene geologic age. The rocks are well exposed on the slopes surrounding the dam where they have been tilted steeply to the northeast at inclinations as great as 70 to 80 degrees. The units are fractured but well cemented, resistant to erosion and form prominent northwesterly-trending strike ridges.

Sandbars, and levies are locally present within the lake and derive from the immediate watershed areas and consist largely of sand-silt mixtures. Siltation of the reservoir occurs seasonally as flood runoff, primarily from the Santa Ynez River, and secondarily, from several minor watersheds which enter the lake from the north and south. The Gidney and Camuesa Creeks are two of the more significant smaller watersheds.

Earth materials generally consist of interbedded mixtures of sand, silt, and clay with local accumulations of organic matter and thin layers of gravelly sand and silt. Lake deposits are wet, very soft to medium dense, generally uniform, massively bedded, and rarely show visible stratification.

Minor organic matter, visible as dark grey to black decomposed vegetation, is characteristically found throughout the lake. Sediment sorting follows a finding of sediment toward the dam following a delta type depositional environment.

In 1920, the Gibraltar Dam was constructed, creating a reservoir that had an initial capacity of 14,500 acre feet. By 1944, the active capacity of the reservoir had been reduced to 7,500 acre feet. In 1949, the Gibraltar Dam was raised another 23 feet, increasing the storage capacity to 15,000 acre feet, an increase of 7,500 acre feet, making the total capacity of the lake 22,000 acre feet. In 1969, the active capacity had been reduced even further to 9,600 acre feet, due to siltation. In 1973, the capacity was determined to have fallen even further to 9,200 acre feet. In May of 1979, the active capacity of the lake was determined to be 8,900 acre feet. The reduction of capacity from 22,000 to 8,900 represents a total of 22,000,000 cubic yards of silt that has washed into the lake in the past 61 years. During the winter months, the water is only 50 feet deep, while the silt is 109 feet deep.

Such a large amounts of silt come from forest fires in the general area. With four major forest fires occurring in the 61 years, there have been substantial increases in siltation 10 years after each fire.

Mining in the Santa Ynez Watershed has created another problem with the silt. Mining has occurred primarily along the large outcropping of cinnabar extending northwesterly from Gibraltar Lake. In 1936, Congress withdrew three-quarters of the watershed from mineral entry for the protection of the watershed and its water resources from erosion, sedimentation, and water pollution. In 1970, the California Regional Water Quality Control Board issued more stringent regulations aimed at controlling waste discharge from a mercury mine on the shore of Gibraltar Lake, because of possible contamination of Santa Barbara's water supply. Activity in the mine has now stopped, but mercury from the old mine tailings attaches itself to the very fines of the silt and remains solely in the silt. It does not appear in the water unless the silt is disturbed.

Contaminants Present: In mid October, 1980, mercury content of sediments and waters prior to dredging, values for sediments ranged from 0.08 ppm at Station F to 0.29, 0.27, and 0.47 ppm at stations A, B, and D. the later 3 stations be future dredging sites.

April 1981 Mercury levels in Water and Sediment:

Station	Depth	Mercury (ppm)
A	0	<0.0005
	7.5	<0.0005
	14.5	<0.0005
B	0	0.0006
	7.5	<0.0005
	14.5	<0.0005
C	0	<0.0005

Pneuma, Hydraulic Dredge

20-Jan-98

	7.5	<0.0005
	14.5	<0.0005
D	0	<0.0005
	7.5	<0.0005
	14.5	<0.0005
E	0	<0.0005
	7.5	<0.0005
	14.5	<0.0005

Bottom Sediment Station:

A	0.60
B	0.44
C	0.52
F	0.66

Water Quality: Mixing occurs from the late fall to spring, typical of relatively warm lakes. In late summer the stratification becomes well established, resulting in stagnation of the hypolimnetic waters which leads to severe oxygen depletion. Consequently, from mid-June through October, the concentration of dissolved oxygen in the bottom waters seldom exceeds 1 mg/l. These depths are therefore not conducive to fish populations, and the underlying sediments become anaerobic also, and will not support a typical aerobic benthic community.

Due to the fact that the lower sections of the lake have a oxygen deprived environment, mercury can be transformed to methyl mercury, which is very toxic and readily taken up by aquatic organisms.

Results of mercury analyses of water samples reported by Ecological Research Associates (1977) showed mercury levels in the water column were low (<0.005 ppm). However, mercury levels were much higher in the analyses of sediment samples. Total mercury concentrations in fish have also been shown at time to be relatively high (0.2-0.8 ppm).

By-mid October 1980, the lake was destratified and no longer showed signs of pronounced oxygen depletion. At this time prior to dredging, levels of both nitrogen and phosphorus were extremely low.

There were no significant differences in colour in any of the stations A, B, or C. However, at station E values were at times high due to large amounts of suspended silt in the water.

Turbidity: In April of 1981, turbidity values at station A (x=1.7 NTU's), were not significantly different than at station C (x= 2.0 NTU's), and all values at station F were equally low except for a single high value (7.9 NTU) at 10 m near bottom.

Total Suspended Solids:		Levels of Turbidity, Suspended Solids:	
Date/Station	Turbidity (NTU) surface/mid-depth	Susp. Solids (mg/l)	
March A	2.45/2.05	2.6/3.5	
B	1.85/1.3	---	
C	---	---	
E	44.28	214.5	
April A	0.87/1.14	1.76/4.56	
B	0.86/0.90	---	
C	---	---	
E	27.40	67.8	
F	1.1/1.2	1.2/19.6	
May A	0.87/0.79	2/0.2	
B	0.42/0.45	---	
C	---	---	
E	0.99	1.8	
F	0.73/0.84	0.8/1.4	
June A	0.62/0.73	1.6/1.6	
B	0.65/0.56	---	
C	---	---	
E	23.5	289.6	
F	1.26/2.28	2.3/19.8	

Suspended solids:

In April 1981, small differences were observed in the mean suspended solids level for the water column at Station A as compared to station C. In the July Survey, which was carried out when the dredge was in actual

Pneuma, Hydraulic Dredge

20-Jan-98

operation, there was a slight elevation in suspended solids concentration (4.6 mg/l). Except for station A (12 mg/l), station and C (3.0 mg/l) and the above example, all stations at all depths had a suspended solids concentration of less than 3.2 mg/l.

Percent Solids: 40% - 50%

Site Containment Used? No Yes

Exceed Set Standards?

Description: Removal Rate:

The equipment used, two 1,400 CFM and one 1,600 CFM air compressors by Ingersol Rand, and a 14" steel discharge pipe. This equipment pumped an average of 700-800 C.Y. of slurry per hour at an average velocity of 7-9 feet per second with an average of 40-50% solids, a distance of 2300' and 170' of vertical head.

The consistency of the slurry pumped was of a milkshake with solid chunks of clay in the slurry. When most pumping was done, only the two 1,400 CFM air compressors were being used to push the material up to the canyon disposal site.

Debris in the silt, wood and rocks, would chew up the fittings and not allow the valve to close properly therefore losing our air pressure. A major shut down was required to remedy this problem. Another problem with the pump was that the welding of the metal inside the pump was experiencing failure and the contractor was having to patch and mend continuously. Once the repairs were completed, the pump performed at its maximum output range.

Amount Removed in-situ(m3):

To provide the proper solution to Santa Barbara's water supply problem, a potential removal of 16,720,000 m³ of silt is required.

Removal Cost:

Total funds used for the proposed project are \$2,255,000. This shows a unit cost of 9.76 \$(US)/m³.

Mobilization Time (days):

When the pump arrived on the project and it was ready to be fitted to the barge, it was found that the wrong dimensions had been sent from the factory in Italy for the fabrication of the barge. This caused a delay of approximately 5 days. When pumping started on November 19th, 1980, the Italian engineer stated that the discharge lines were not fabricated properly and were causing restrictions in the discharge of air and slurry. Three weeks were spent rectifying these problems through a process of trial and error. After this problem was solved, it was discovered that part of the problem was with the pump itself. After a 2 week period of trial and error of changing internal parts and adjustments, the entire system started performing as it was expected.

- 2 1,400 CFM air compressors
- 1 1,600 CFM air compressor
- 14" steel discharge pipe

Demobilization Time (days):

Dredging extended into August 1981.

Regulatory Approvals:

A grant application was made by the Mayor of Santa Barbara to the US EPA on May 7, 1977.

Disposal:

An 85 foot high silt retention embankment within the North Side West Disposal Area was proposed. The North Side West Disposal Site Phase Pilot Project will accommodate 200,000 cubic yards of silt.

Bibliography:

City of Santa Barbara. Gibraltar Lake Restoration Project: Final Report. Spencer Engineering. October 1981.

Technology Type: Hydraulic, Pneumatic

System Works With: Debris

Development Stage: Commercial

Country Of Origin: Germany

Description:

Airlift principle; low pressure air is pumped into the water through a double shell pipe. Air expands in the delivery pipe and creates strong underpressure/suction. Hardly any wear as solids don't have to pass through pumps, etc. Handles large size diameter particles. Very efficient in medium to large depths. Side effect: water ventilation (system can also be used for water aeration).

Projects: Numerous silt removals. Dredging in depth to 100 m. Engineering jobs (pile drilling, offshore platform, underwater cables and pipelines, harbour construction).

Limitations: Minimum depth below water should be 10 m. Excellent rising, limited horizontal pumping efficiency.

Type of Power: Electricity; diesel; as required.

Government Funding:

Environmental Concerns: Side effects: Aeration, little disturbance, no negative effects (OKO-certified).

Health & Safety Plan Available:

Regulatory Approvals Accepted in water protection areas (Germany).

Setup/Feed: Mobilization (days):

Demobilization (days):

Removal Rate Average (m³/hr): 300

Cost: Capital Cost (US\$): \$165,000.00

Unit Cost (US\$/m³): \$0.00 -

Average Cost (US\$/m³):

Capital cost applies to suction dredge model DA 200. Removal rate: 60 - 550 m³/hr depending on material flow and dredge type.

Developers:

Pressair International

P.O.B. 801426

Munchen,

Germany

81614-

Notes

Contact: Troendle, K.

Phone: (089) 430-3337

Ext:

Fax: (089) 439-2694

Email:

Vendors:

Pressair International

P.O.B. 801426

Munchen,

Germany

81614-

Notes

Contact: Troendle, K.

Phone: (089) 430-3337

Ext:

Fax: (089) 439-2694

Email:

Literature References:

Author: Troendle, Karl

Title:

Journal: World Dredging & Marine Construction

Date: Nov 1984

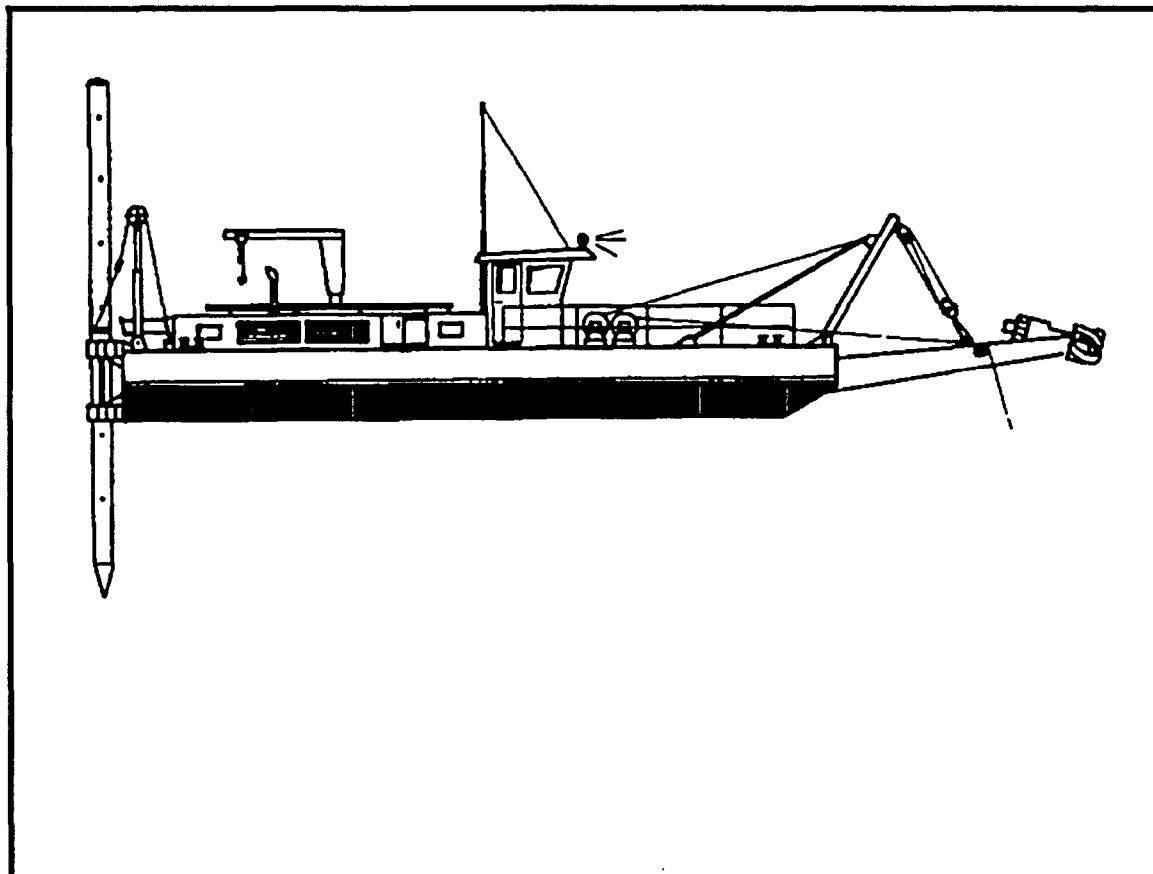
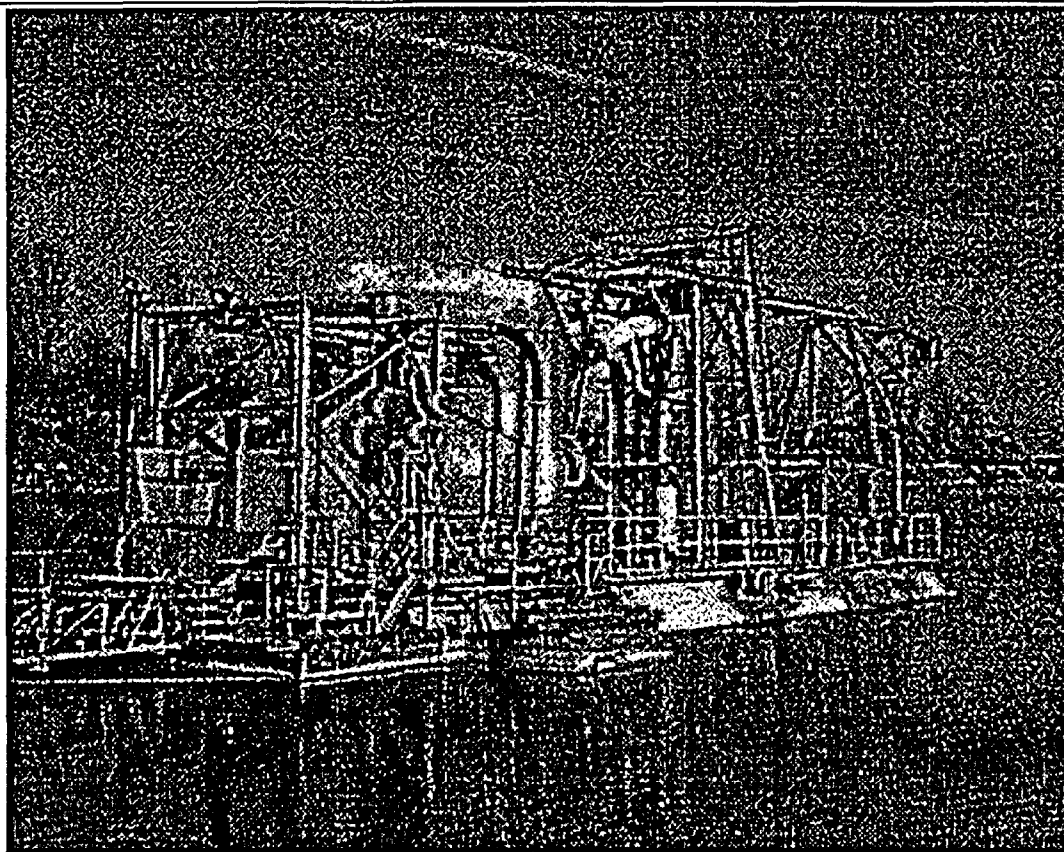

Rinkai Construction Co. Ltd., Pulse Air Type High Density Sludge Transport Ship

20-Jan-98

TechID: 291

Technology Type: Pncumatic

System Works With: Debris

Development Stage: Commercial

Country Of Origin: Japan

Description:

The system transports high density dredged sludge under pressure with no added water. Compressed air is intermittently injected into a sludge pipe to generate a pulse flow for pressurized sludge transport.

The advantages of this portable system include the fact that it can be used for work in small and medium rivers and lakes.

The system was used for projects of up to 50,000 m³ in Chiba and Saitama Prefectures.

Limitations:

Type of Power:

Government Funding:

Environmental Concerns:

Health & Safety Plan Available:

Regulatory Approvals

Setup/Feed: Mobilization (days):
Removal Rate Average (m³/hr): 100

Demobilization (days):

Cost: Capital Cost (US\$):
Unit Cost (US\$/m³): -

Average Cost (US\$/m³): \$10.00

Developers:

Rinkai Construction Co., Ltd.
Technical Division, 2-3-8 Shiba,
Tokyo,
Japan 105 -
Notes

Contact: Corporate Technical Department,
Phone: 81354761728 Ext:
Fax: 81334531678
Email:

Vendors:

Rinkai Construction Co., Ltd.
Technical Division, 2-3-8 Shiba,
Tokyo,
Japan 105 -
Notes

Contact: Corporate Technical Department,
Phone: 81354761728 Ext:
Fax: 81334531678
Email:

Literature References:

Rinkai Construction Co. Ltd., Screw Conveyor Type Mud Collector

20-Jan-98

TechID: 296

Technology Type: Mechanical

System Works With: Water Depth 2-10m

Development Stage: Full Scale Demo

Country Of Origin: Japan

Description:

As the screw conveyor rotates, the dredged earth and sand are transported horizontally and sucked by pump, enabling dredging of earth and sand with a high sludge content.

The system is effective for thin-layer dredging of approximately 30 cm in depth. The system has not yet been operated on site.

The system can dredge up to approximately 10 m in water depth and is installed on portable pump ships.

Limitations:

Type of Power:

Government Funding:

Environmental Concerns:

Health & Safety Plan Available:

Regulatory Approvals

Setup/Feed: Mobilization (days):
Removal Rate Average (m³/hr): 50

Demobilization (days):

Cost: Capital Cost (US\$):
Unit Cost (US\$/m³): -

Average Cost (US\$/m³): \$10.00

Developers:

Rinkai Construction Co., Ltd.
Technical Division, 2-3-8 Shiba,
Tokyo,
Japan 105 -
Notes

Contact: Corporate Technical Department,
Phone: 81354761728 Ext:
Fax: 81334531678
Email:

Vendors:

Rinkai Construction Co., Ltd.
Technical Division, 2-3-8 Shiba,
Tokyo,
Japan 105 -
Notes

Contact: Corporate Technical Department,
Phone: 81354761728 Ext:
Fax: 81334531678
Email:

Literature References:

Technology Type: Hydraulic

System Works With: Limited Shore Access

Development Stage: Commercial

Country Of Origin: Japan

Description:

Advantages of the No. 1 Mud Cleaner:

- (1) The No. 1 Mud Cleaner can dredge sludge in almost the same state as it was accumulated on the bottom bed.
- (2) Turbidity during dredging is reduced.
- (3) The amount of excess water required for treatment and the risk of secondary pollution are reduced.
- (4) The No. 1 Mud Cleaner can be also used in comparatively narrow water areas because of its easy assembly, disassembly, and transportation.
- (5) The No. 1 Mud Cleaner can be hauled long distances.

Since the equipment can be easily assembled, disassembled, and transported, it can be used in comparatively narrow water areas.

Examples of use:

- Dredging in the Ohtsu region (Lake Biwa)
- Verification dredging in the Kumamoto region (Shioya)
- Modification work on and industrial waste treatment facility for the Fukukou Kousan Company

Limitations:

Type of Power:

Government Funding:

Environmental Concerns:

Health & Safety Plan Available:

Regulatory Approvals Technology Evaluation Certificate by Ministry of Transport (No. 93109) for [High-Density Sludge Dredging and Discharging Method of Sludge] (June 30, 1993).

Setup/Feed:	Mobilization (days):	Demobilization (days):
	Removal Rate Average (m³/hr): 50	
Cost:	Capital Cost (US\$):	Average Cost (US\$/m³):
	Unit Cost (US\$/m³): -	

Removal rate: 50 m³/hr (8 hrs of operation per 10 hrs of dredging work).

Developers:

Saeki Kensetsu Kogyo Co. Ltd.
Corporate Civil Engineering Department
Osaka, 541,
Japan
Notes

Contact: Kanayama,
Phone: (816) 203-4842 Ext:
Fax: 0118162334626
Email:

Vendors:

Saeki Kensetsu Kogyo Co. Ltd.
Corporate Civil Engineering Department
Osaka, 541,
Japan
Notes

Contact: Kanayama,
Phone: (816) 203-4842 Ext:
Fax: 0118162334626
Email:

Literature References:

Author: Japan Working Ship Association
Title:
Journal: Working Ship, Vol. 208, 1994

Date: Jan 1994

Author: Japan Dredging and Reclamation Engineering Association
Title:
Journal: Marine Voice, Vol. 176

Date: Mar 1994

Technology Type: Hydraulic

System Works With: Debris, Water Depth 2-10m

Development Stage: Commercial

Country Of Origin: Japan

Description:

Among the working vessels for long-distance, high density sludge transportation, this ship is designed with the highest available capacity of 600 m³/hour (300 m³/hour x two feeders).

There is little excess water because the sludge is fed by pressurized air in a high-density state with no added water.

A large amount of sludge can continuously be transported over a long distance.

Examples of use: Special emergency work in the Unzen regoin as a counter-measure against damage by volcanic ash disaster.

: Improvement work of Shin Moji breakwater (B), revetment A, and revetment for Shin Moji B.

Limitations:

Type of Power:

Government Funding:

Environmental Concerns:

Health & Safety Plan Available:

Regulatory Approvals

Setup/Feed: Mobilization (days):

Demobilization (days):

Removal Rate Average (m³/hr): 600

Cost:

Capital Cost (US\$):

Unit Cost (US\$/m³):

-

Average Cost (US\$/m³):

Removal rate: 600 m³/hr (eight hours of operation per ten hours of dredging work; 300 m³/hr x 2 feeders).

Developers:

Saeki Kensetsu Kogyo Co., Ltd.

Corporate Civil Engineering Department, Technical

Osaka,

Japan

541 -

Notes

Contact: Kanayama,

Phone: (816) 203-4842

Ext:

Fax:

Email:

Vendors:

Saeki Kensetsu Kogyo Co. Ltd.

Corporate Civil Engineering Department

Osaka, 541,

Japan

Notes

Contact: Kanayama,

Phone: (816) 203-4842

Ext:

Fax: 0118162334626

Email:

Literature References:

Technology Type: Pneumatic

System Works With: Limited Shore Access

Can be used in comparatively narrow water areas.

Development Stage: Commercial

Country Of Origin: Japan

Description:

Bottom sediment with such low water content as it is, can be transported over a long distance through the sludge feeding pipe. As sludge is transported through the sludge pipe, offensive odors are eliminated. Because less excess water is involved in the dredging operation, the area for reclamation can be reduced in size, and can be dried faster. By increasing the pressurized transportation unit, the discharging sludge can be increased in quantity.

Examples of use: *Wakagawa River pressurized transportation work

*Miwa Dam verification work

*Maintenance work on the small and medium-sized tributaries of the Daido River

*Maintenance work on a berth in the West No 3 Section of the Nagoya Port

*Scabed excavation work (12 meters) on the Kasumigaura Wharf and wharf construction work on the Yokkaichi Port.

Limitations:

Type of Power:

Government Funding:

Environmental Concerns:

Health & Safety Plan Available:

Regulatory Approvals Technology Evaluation Certificate No. 93110 for [High Density Sludge Dredging and Discharging Method] (June 30, 1993) by Ministry of Transport (Japan).

Setup/Feed: Mobilization (days):
Removal Rate Average (m³/hr): 60

Demobilization (days):

Cost: Capital Cost (US\$):
Unit Cost (US\$/m³): -

Average Cost (US\$/m³): \$30.00

Removal rate: 60 m³/hour - 7 hours of operation per 8 hours of dredging work. Cost average: Under the conditions of viscous sediment and L = 2,000 m.

Developers:

Saeki Kensetsu Kogyo Co. Ltd.
Corporate Civil Engineering Department
Osaka, 541,
Japan
Notes

Contact: Kanayama,
Phone: (816) 203-4842 Ext:
Fax: 0118162334626
Email:

Vendors:

Saeki Kensetsu Kogyo Co. Ltd.
Corporate Civil Engineering Department
Osaka, 541,
Japan
Notes

Contact: Kanayama,
Phone: (816) 203-4842 Ext:
Fax: 0118162334626
Email:

Literature References:

Sanexen, Vacuum Clam Dredge

20-Jan-98

TechID: 358

Technology Type: Hydraulic, Mechanical

Water to solids ratio minimized.

System Works With: Debris, Strong Currents, Water Depth 2-10m, Limited Shore Access, Water Depth < 2m

Works in depth > 10 m with extensions.

Development Stage: Full Scale Demo

Country Of Origin: Canada

Description:

Using a barge mounted Poclair(TM) hydraulically operated clam on a swiveled arm, the sediment grabbing clam was built to be totally enclosed (rather than open at the top) when closed. In addition, an outer shell, with gaskets, independently operated, closes around the clam after the clam has grabbed the sediments. After closing, the inner clam is under a controlled vacuum while the space between the clam and the shell is pumped out (slowly when under water, quickly when above water) to prevent the loss and resuspension of contaminated sediments.

Limitations: Large debris, rock that prevents the proper closing of the clam and shell assembly.

Type of Power: Diescl

Government Funding:

Environmental Concerns: The equipment was surrounded with an oleophilic silt curtain downstream, coupled with water treatment unit.

Health & Safety Plan Available:

Regulatory Approvals MOE, 1987, Chippawa Creek

Setup/Feed: Mobilization (days): 10

Demobilization (days): 5

Removal Rate Average (m³/hr): 6

Cost: Capital Cost (US\$): \$150,000.00

Unit Cost (US\$/m³): \$30.00 -- \$200.00

Average Cost (US\$/m³): \$50.00

The technology is for contaminated sediments.

Developers:

Sanexen Environmental Services, Inc.

579 Le Breton
Longueuil, Quebec
Canada J4G1R9

Notes

Contact: Paquin, Jean

Phone: (514) 646-7878

Ext:

Fax: (514) 646-5127

Email:

Vendors:

Acres & Associates

5259 Dorchester Rd.
Niagara Falls, ON
Canada L2E6W1

Notes

Contact: Miles, Phil

Phone: (905) 374-5200

Ext:

Fax: (905) 374-1157

Email:

Sanexen Environmental Services, Inc.

579 Le Breton
Longueuil, Quebec
Canada J4G1R9

Notes

Contact: Paquin, Jean

Phone: (514) 646-7878

Ext:

Fax: (514) 646-5127

Email:

Literature References:

Author: Acres International Limited

Title: Chippawa Creek Cleanup: Report on Cleanup Activities: April 1987- April 1989

Journal: Report for the Ontario Ministry of the Environment

Date: May 1989

Project: Chippawa Creek Cleanup

Year 87

Location: Welland, Ontario, Canada

Full Scale Demo

Client/Funding Agency	Contact	Phone
Ministry of the Environment - Ontario	Bob Slatterg	(905) 732-4850

Not Monitored

Removal Rate(m³/hr): 6 Amount Removed In-Situ (m³): 1300

Removal Cost(US\$): \$400,000.00

Mobilization (days): 10 Demobilization (days): 5

Site Conditions: 1 m/sec.; 0-6 m; 1-1.5 m; Tar laden material

Contaminants Present: Polyaromatic Hydrocarbons
Suspended Matter

Water Quality:

Turbidity:

Total Suspended Solids:

Percent Solids:

Site Containment Used? No Yes

Oleophilic double layer silt curtain around area of concern. Boom and sorbents also deployed.

Exceed Set Standards?

Description: This cleanup was undertaken in several phases over a 2 1/2 year period on behalf of the Ontario Ministry of the Environment (MOE), Norton Advanced Ceramics of Canada Inc. (Norton Co.) and Ontario Hydro. All clean-up activities between July 1987 and January 1989 were carried out under the supervision and direction of Acres International Limited. The cleanup included both the riverbed and shoreline, and the clean-out and decommissioning of a settling lagoon used to temporarily store contaminated sediment and water. As of May 1989, all contaminated sediments from the riverbed and shoreline were disposed of at Tricil (Sarnia) Limited secure landfill, while all contaminated water was treated and released to the regional sanitary sewer system. The Norton Co. settling lagoon was decommissioned and site restoration involving the replacement of docks, tree transplanting and replacement of topsoil and seeding was also completed.

The proposed cleanup methodology emphasized preventing the release of sediments downstream while maintaining a high ratio of solids excavated to water generated. The cleanup of the riverbed involved (1) excavation of the contaminated sediments using a specially designed hydraulic-controlled vacuum clam mounted on a barge (2) transfer of the excavated slurry into lugger boxes for hauling the decanted water by vacuum truck and the solids by roll-on, roll-off trucks to a 5500 m³ settling lagoon for water separation and temporary storage.

The cleanup of the shoreline involved (1) installation of a temporary sheetpile wall along the shoreline to prevent sediment loss (2) excavation of the contaminated sediments in the wet using conventional earth moving equipment (3) decanting and transfer of the excavated slurry to a fixation area for solidification of the solids (4) hauling the fixed material to a secure landfill for final disposal.

Sevenson Environmental, Hydraulic Cutter

20-Jan-98

TechID: 370

Technology Type: Hydraulic

System Works With:

Development Stage: Commercial

Country Of Origin: USA

Description:

Limitations:

Type of Power:

Government Funding: Superfund

Environmental Concerns:

Health & Safety Plan Available:

Regulatory Approvals

Setup/Feed: Mobilization (days): Demobilization (days):

Removal Rate Average (m³/hr):

Cost: Capital Cost (US\$):
Unit Cost (US\$/m³): \$0.00 - Average Cost (US\$/m³):

Developers:

Sevenson Environmental Ltd.
2749 Lockport Road
Niagara Falls, NY
USA 14305-
Notes

Contact: Stoutamire, Pat
Phone: (716) 284-0431 Ext:
Fax: (716) 284-1796
Email:

Vendors:

Sevenson Environmental Ltd.
2749 Lockport Road
Niagara Falls, NY
USA 14305-
Notes

Contact: Stoutamire, Pat
Phone: (716) 284-0431 Ext:
Fax: (716) 284-1796
Email:

Literature References:

Sevenson Environmental, Hydraulic Cutter

20-Jan-98

Project: General Motors Plant

Year 93

Location: Massena, NY, USA

Commercial

Client/Funding Agency	Contact	Phone
General Motors Corporation US EPA	Tom Donovan Lillian Johnson	(315) 764-2273 (212) 637-3675

* Monitored * Auditor: Ian Orchard (Environment Canada) Phone: (416) 739-5874

Removal Rate(m³/hr): Amount Removed In-Situ (m³): 13680

Removal Cost(US\$):

Mobilization (days): Demobilization (days):

Site Conditions: River bottom sediments. The dredging site is located on the St. Lawrence River, 0-75 m from shore. Currents in front of the GM property are measured at 0.6 m/sec. The shipping channel, where the velocity can reach 2 m/sec is 100 m from shore.

Contaminants Present: After the dredging was completed, the river bottom was divided into sections or "grids", and samples of remaining sediments were collected to ensure that the dredging program had met EPA's cleanup goal of 1 part per million (ppm). An analysis of the samples indicated that PCB concentrations in all areas except one averaged less than 3 ppm.

The area adjacent to the GM plant outfall, however, continued to show elevated PCB levels during dredging. Despite repeated dredging attempts, final sampling results showed an average of 25 ppm. With the exception of one sample at 6,000 ppm (out of a total of 113 different sample locations in the river), none tested above 100 ppm. By early November, EPA determined that continued dredging was not likely to result in further PCB reduction.

Water Quality: General Motors Monitoring Activities:

During the dredging, drinking water intake monitoring was done on a daily basis at the St. Regis Mohawk Tribe's and GM plants. The sampling at the St. Regis Mohawk Tribe's water intake changed to weekly when dredging in the most highly contaminated areas was completed. PCB's were not detected in Tribal intake water.

A leak in the GM drinking water intake line (from within the dredging containment area) was determined to be the cause of elevated levels at the GM plant. The company provided bottled water to its employees and subsequently installed carbon filtration. PCB's were not detected in the plant's water following these actions.

Environment Canada Monitoring Activities:

Environment Canada, as a cooperative undertaking with EPA, conducted river water quality monitoring immediately adjacent to the GM dredge site during the sediment removal activities. The intent of Environment Canada's sampling was to corroborate and complement the monitoring required of the company by EPA. Beginning on July 11 (1995), Environment Canada collected whole water samples for PCB analysis daily on weekdays until July 21. The following week, collections were made once a day for three days and were subsequently reduced to twice per week. Turbidity measurements were recorded while the water samples were being collected. Additional turbidity monitoring along the wall of the containment area was also undertaken. This program continued throughout the dredging program.

Turbidity: Turbidity measurements were recorded while water samples were being collected (by Environment Canada). Additional turbidity monitoring along the wall of the containment area was also undertaken.

Total Suspended Solids: Daily monitoring detected no excursions of the EPA action level for TSS (25 ppm).

Percent Solids:

Site Containment Used? No Yes

GM placed a steel sheet pile wall between the sediment removal area and the main river channel. The wall formed a barrier that prevented resuspended sediments from leaving the dredging area and moving downstream. Contractors encountered repeated difficulties with anchoring of the curtains.

Exceed Set Standards? GM, under EPA guidance, monitored air, water and turbidity in the water on a daily basis. The objective of the monitoring was to ensure that the following health-based target levels were not exceeded during dredging: (1) PCB's in Air : 100 nanogram/m³ (2) PCB's in Water : 2 ppb (3) Turbidity : 29 NTU's greater than the upstream reference station. If any of the targets were exceeded, EPA would have ensured that GM took corrective actions, including stopping work if necessary.

Description: The US EPA and General Motors Corporation successfully removed over 13,500 m³ of contaminated sediments from the St. Lawrence River next to GM's Massena, New York Plant. The U.S. Army Corps of Engineers assisted EPA in overseeing the work. The section of the river bottom that was dredged contained elevated levels of polychlorinated biphenyls (PCB's).

Excavation of boulders, debris, and aquatic weeds began in June 1995. The mechanical removal work was followed by dredging and pumping of sediments through a floating pipeline to a collection basin on shore. Here, the sediments were screened to remove large debris. Excess water was removed from the sediments, treated to eliminate any contaminants,

Sevenson Environmental, Hydraulic Cutter

20-Jan-98

and then discharged back into the river. The dewatered sediments were pressed into forms (cakes) and placed in a lined stockpile area. This work was completed on November 7, 1995. Later in 1996, EPA and GM plan to remove PCB-containing sediments from a cove bordering the St. Regis Mohawk Reservation. EPA and GM had intended to remove the sediment from the cove in 1995, but the work was postponed due to difficulties obtaining access to the area.

EPA's original cleanup plans for the site included on-site treatment of all soils, sediments and sludges with PCB concentrations above 10 ppm. A significant amount of new information was gathered during the remedial design in 1993 and 1994. In June 1995, EPA issued a Post-Decision Proposed Plan that called for on-site treatment using thermal extraction for materials with PCB's above 500 ppm and on-site containment of materials with lower PCB concentrations. EPA will inform the public of its decision regarding the Post-Decision Proposed Plan later this year (1996).

Soli-Flo, Eddy Pump Technology

20-Jan-98

TechID: 346

Technology Type: Hydraulic

System Works With: Debris, Strong Currents, Water Depth 2-10m, Limited Shore Access, Water Depth > 10m

Development Stage: Commercial

Country Of Origin: USA

Soli-Flo, Eddy Pump Technology

20-Jan-98

Description:**Description 40 cm Dredge:**

The Dredge System (as it is called) provides a revolutionary approach for silt and sludge removal from reservoirs, lakes, rivers and other similar environments. At the heart of the system is an Eddy Pump®; a unique cyclonic pump which is highly efficient in the extraction of silt, sand, debris aggregate and other material while maintaining extremely low turbidity. Its efficient design allows pumping this extracted material great distances from the dredge site. The Dredge System+ is the vehicle by which the pump is positioned around the work site. It can move in any horizontal position while maintaining vertical stability. This is especially important where vertical changes vary throughout the day. In certain reservoirs the daily fluctuations of water elevation can exceed 6 m.

The Dredge System is of modular construction and can be assembled or disassembled in less than two days. When assembled it consists of three primary flotation systems; Pump Platform, Control Barge and Instrument Barge. The Pump Platform consists of a square float platform, 15 m on a side with an opening to deploy the pump. Various hydraulic winches and cylinders control the vertical position, sweeping motion and altitude of the pump assembly. The pump assembly consists of a frame, pump, TV camera, 350 hp electric motor and a 10 cm pinch valve. A 10 m x 6 m container houses a 3412 engine generator package, variable frequency drive, cable reel, air compressor and hydraulic controls. The power unit provides electrical power to the pump as well as hydraulic power for the array of winches and positioning cylinders.

The Control Barge consists of a float platform 10 m long and 15 m wide. Mounted crossways in the center of the float is a 10 m container which contains a crew's quarters, a 150 kw electric set, and an overhead control house containing much of the electronic equipment. The control house is mounted on top of the container and contains the PC and PLC for controlling all systems on the dredge, in addition to all monitoring instruments including turbidity meters, sonar monitor, TV monitor and two PC monitors.

The two barges are connected via a conveyor boom. The boom provides both horizontal steering of the Pump Platform through +/- 45 degrees and maintains zero load to the pump head through a hose conveyor system.

An Instrument Barge consists of a float 8 m long by 7 m wide. It trails the Control Barge and is responsible for maintaining consistency in pumping. The barge is at the other end of the hose system and ultimately connects to the extensive piping system in order to transport the pumped material to the dump site. A 5 m container includes a 3306 engine/water pump, for emergency purging of the discharge line, a 25 cm and 15 cm pinch valve and small water pump to charge the main water pump. There are instruments to measure density, flow and pressure and can inject water into the flow if required. It can also evacuate the material from the 40 m hose in the event of the primary pump shutdown. All three barges and the underwater pump platform make up the Dredge System.

Description 12 cm Dredge:

Face Pump Engine: Caterpillar D 333C, 6 cyl Turbocharged Diesel engine, 192 Continuous Horsepower at 1800 RPM.

Hydraulic System: Vickers, Engine driven two stage vane pump-0.1 m³/min at 1800 RPM and 1500 PSI supplying power to the crane, hose reels, and auxiliary valves. Two Sundstrand variable displacement pumps, Direct engine driven through gearbox splitter, supplying power to Sundstrand motor driving a 12 cm Eddy Pump at variable speed from 1200 to 1600 RPM. Hydraulic oil used is Biodegradable oil.

Pump Deployment System: The pump will be suspended from the crane on a pump carrier. Attached to the carrier are winch lines fore and aft of the pump, allowing us to sweep the pump approximately 2.5 m along the bottom, as the dredge moves sideways in a 90 degree arc. There are three winches mounted on the deck of the barge; two of these winches power the pump sweep and one aft winch is used to anchor the dredge. All the winches are powered by a separate power unit.

Pump Elevation Control: The elevation of the pump will be controlled by a laser plane system and electronic depth monitor combined with a three dimensional sonar system allowing the pump to surgically remove the contaminated sediment without removing excess uncontaminated material. In addition, there will be a TV camera trained on the pump intake allowing visual monitoring by the operator plus an onshore monitor.

Dredge Platform: The dredge platform consists of three Flexifloats, two 10 m long x 2.5 m wide, and one 5 m long x 2.5 m wide float mounted across the front of the platform giving us a rectangular platform 11.5 m long. The two 10 m floats will be separated by 1.2 m connecting trusses which will house the main power unit and pump deployment system, plus provide a space between the floats for the 15 cm discharge hose to exit to the rear of the dredge to the instruments float containing the flowmeter, densitometer and pressure sensor. Attached to the rear of the instrument float the 20 cm transportation pipeline will pipe the material to a booster pump on shore which will transport the material to the storage containers. There will also be an electrical and hydraulic power unit and a high pressure water pump on the platform.

Dredge Maneuvering System: Thrusters are employed for maneuvering the dredge. Bow thrusters are mounted on each side of the dredge in the float, and a rear thruster is mounted in the rear to maintain thrust against the anchor. These thrusters allow positioning and moving the dredge from side to side to provide a sweeping action.

Dredge Control House: The control house will be mounted forward on the left side of the dredge where the operator can observe the pump and winch operations at all times. Within the control house is a pump video monitor, a sonar three dimensional bottom video monitor, a pump turbidity meter measuring turbidity in NTU, a flow meter gauge, a densitometer gauge, a pressure gauge to monitor pressure in the pipeline, steering controls for all thrusters and depth gauges for pump depth positioning. A control system for a high pressure water pump is used as a safety system for purging the transport pipeline in the event of a power system failure.

Booster System on the Transport Pipeline: A portable diesel power unit can be deployed with direct driven Eddy Pump attached integrally to

Soli-Flo, Eddy Pump Technology

20-Jan-98

the power unit. Additional booster pumps can be added to the system to achieve significant transport distance.

Limitations: Need minimum 1-2 meters of water depth (required to enable platform to be deployed).

Type of Power: Diesel

Government Funding: Great Lakes Cleanup Fund, SITE, Superfund, ETP

Environmental Concerns: Turbidity monitoring

Health & Safety Plan Available:

Regulatory Approvals California EPA, U.S. Fish and Wildlife

Setup/Feed: Mobilization (days): Demobilization (days):

Removal Rate Average (m³/hr): 230

Cost: Capital Cost (US\$):
Unit Cost (US\$/m³): \$0.00 - Average Cost (US\$/m³):

Developers:

Soli-Flo LLC

8400-J Magnolia Avenue
Santee, CA
USA 92071-
Notes

Contact: Busick, Rick
Phone: (619) 258-2135 Ext:
Fax: (619) 258-0305
Email:

Vendors:

Xetex Corporation

One Rockefeller Plaza
New York, NY
USA 10020-
Notes

Contact: Berns, Michael
Phone: (212) 332-3333 Ext:
Fax: (212) 332-3315
Email:

Soli-Flo

622 Airport Road
Oceanside, CA
USA 92054-
Notes

Contact: Lee, Dana
Phone: (619) 754-3742 Ext:
Fax: (619) 754-3755
Email:

Literature References:

Author: Creek, K.D., Sgraves, T.H.

Title: Eddy Pump Dredging : Does it Produce Water Quality Impacts?

Journal: Waterpower '95

Date: Jul 1995

Author: Harrison, L., Lee, W., Tu, S.

Title: Sediment Pass Through, An Alternative to Reservoir Dredging

Journal: Waterpower '95

Date: Jul 1995

Soli-Flo, Eddy Pump Technology

20-Jan-98

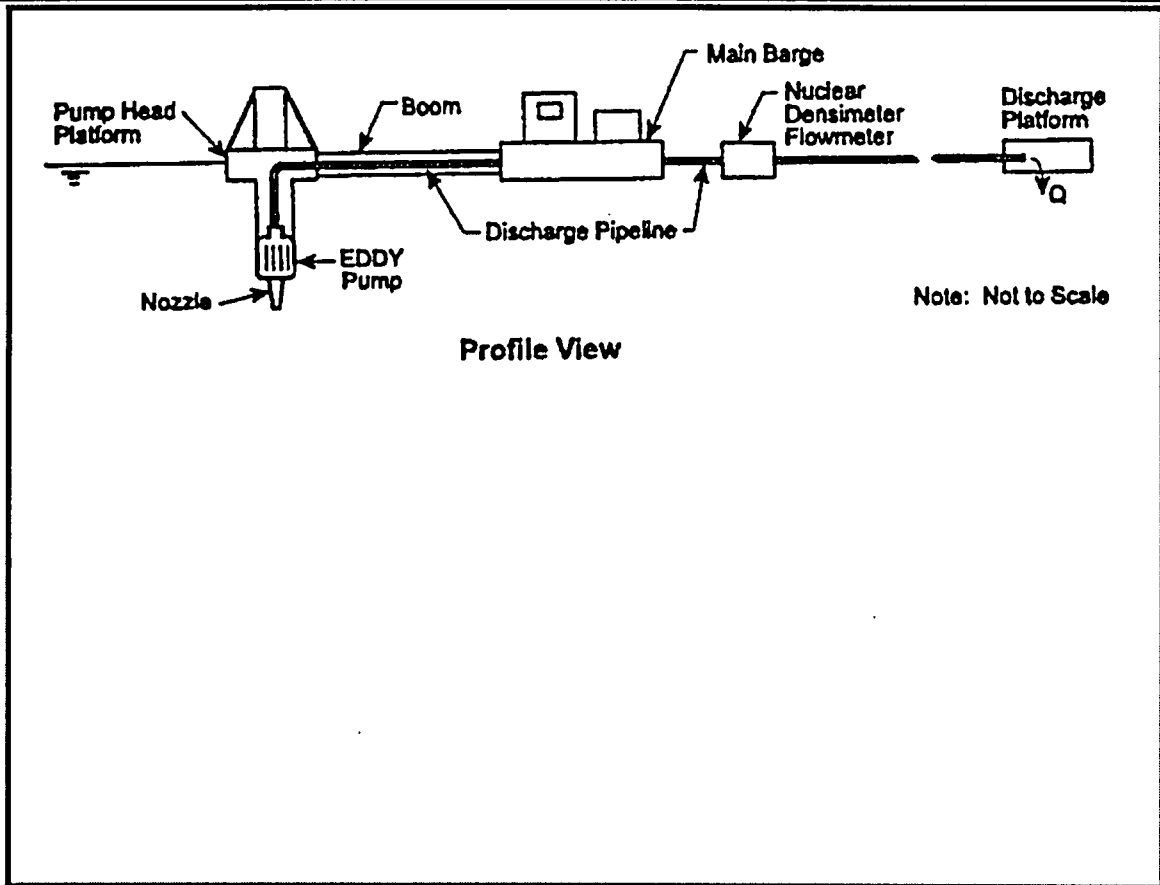

Soli-Flo, Eddy Pump Technology

20-Jan-98

Project: Cresta Dam and Rock Creek

Year 94

Location: Feather River, CA, USA

Full Scale Demo

Client/Funding Agency	Contact	Phone
Pacific Gas & Electric Company	Wing Lee	(415) 973-5310

Not Monitored

Removal Rate(m³/hr): 230

Amount Removed In-Situ (m³): 8000

Removal Cost(US\$):

Mobilization (days): 7

Demobilization (days): 7

Site Conditions: Water Depth to 20 m, average 1 m/sec current; Sand, gravel & debris sediments (to 1.5 m).

Rock Creek and Cresta dams were completed in 1950 and 1949 respectively to further develop the hydro power resources of the NFFR. Poe Dam was completed in 1958. Rock Creek Reservoir is the forebay for the 112,000 kW Poe Powerhouse. The concrete gravity dams were built as run-of-the-river diversion structures to divert the river flows through tunnels to the powerhouses. The dams were designed to be capable of safely passing flood flows, releasing regulated stream flow to protect aquatic habitat, and draining the reservoirs for maintenance. Rock Creek and Cresta dams are each equipped with three low level outlets, approximately 2.4 m in diameter.

Over the past 45 years, sediments have accumulated in the Rock Creek and Cresta Reservoirs resulting in potential reduced reliability of dam and powerhouse operations. Operational problems due to sediments began at Rock Creek Reservoir in the early 1980's and at Cresta Reservoir in 1986. Watershed studies have identified unregulated tributaries of the NFFR as the major contributors of sediments to the reservoirs.

The February 1986 record flows in the NFFR exacerbated the sedimentation problem in Cresta Reservoir by depositing an additional 230, 000 m³ of sediment in the reservoir and by shifting sediments downstream within the reservoir to the dam and intake structure, where they have a disruptive effect on dam and powerhouse operations. The sediment deposits at the dams reduce the overall reliability of hydroelectric operations by accelerating wear on the powerhouse turbines and generally increasing maintenance needs. In addition, the sediments are partially obstructing the low-level dam outlets, fish water release piping, and piping for operating the spillway drum gates. Trash racks at the intake structures could become plugged and then collapsing should a sudden buildup of sediments and debris occur during operation. For this reason, normal flushing operations of the low level outlets at the dams have been restricted for the past several years, exacerbating the sediment deposition problems. Also, the spillways at Rock Creek and Cresta dams are equipped with over-the-top spilling drum gates which are ineffective to pass sediment bed-load mobilized during flood flows.

A sediment survey conducted in 1994 indicated that Rock Creek Reservoir contained approximately 3.1 million m³ of sediments, which displace 58 % of its original water storage capacity of 5.4 million m³. Cresta Reservoir, also surveyed in 1994, contained approximately 2.45 million m³ of sediments, displacing 48 % of its original water storage capacity of 5.1 million m³. Poe Reservoir was surveyed in 1993 and found to contain 358,000 m³ of sediment, which displaces 25 % of its original capacity of 1.42 million m³. Due to the smaller size of the Poe Reservoir, and the design of the dam spillways using large radial gates, the sediment accumulation in Poe does not cause operating problems, and the sediment volume in Poe is not expected to significantly increase in the future.

Contaminants Present: None

Water Quality: Water quality was monitored daily to ensure compliance with limitations set by the California Regional Water Quality Control Board. Those limitations stipulated that turbidity near the intake to Cresta Powerhouse could not exceed 25 Nephelometric Turbidity Units (NTU's) over ambient background.

Turbidity: Background 0.5 to 1.0 turbidity.

Total Suspended Solids: California Regional Water Quality Control Board limitations stipulated that total suspended solids (TSS) could not exceed an absolute maximum of 80 mg/l. Additional TSS monitoring was also performed upstream and downstream of the discharge platform and around the pump head platform. Increases in TSS downstream of the discharge site were minor.

Percent Solids: 140 (80% (by volume)

Site Containment Used? No Yes

Exceed Set Standards? Turbidity and TSS values near the intake to Cresta Powerhouse remained well below limitations set by the California Regional Water Quality Control Board.

Description: The feasibility of the Eddy Pump was evaluated during a prototype demonstration at Cresta Reservoir. During the demonstration, the Eddy Pump's vertical position was controlled by four cables suspended from a pump head platform. Dredged sediment passed through a floating pipeline, and was discharged back into Cresta Reservoir at a surface platform 600 m upstream. Along its route, the pipeline traversed a 25 m boom and the main barge, and passed through an induction-type flow meter and a nuclear densimeter used to monitor mass flow rate. The main barge, which housed a control room, generator, and auxiliary water pump, was positioned horizontally by four mooring winches. The boom, which connected

Soli-Flo, Eddy Pump Technology

20-Jan-98

the pump head platform and main barge, also added horizontal mobility by pivoting about the barge.

Conclusions: Turbidity and TSS were typically unaffected around the pump head platform during the demonstration. Using upland disposal, Eddy Pump dredging of sandy material should not produce significant water quality impacts.

Even with in-reservoir disposal, turbidity and TSS values near the intake to Cresta Powerhouse remained well below limitations set by the California Regional Water Quality Control Board. Increases in the values of these parameters were minor even directly downstream of the discharge platform, and although not applicable at that location, would have met the limitations. Dissolved Oxygen was unaffected during the demonstration. Eddy Pump dredging of sandy material, using in-reservoir disposal, should produce only minor water quality impacts.

SRS Crisafulli, Rotomite 180P

20-Jan-98

TechID: 345

Technology Type: Hydraulic

System Works With: Debris, Water Depth 2-10m, Limited Shore Access, Water Depth < 2m
Debris 10 cm ; Max. depth 5m

Development Stage: Full Scale Demo **Country Of Origin:** USA

Description:

The Rotomite 180P is a manned, portable, self-propelled, diesel/hydraulic floating dredge suitable for removing sludge from a lagoon without extensively dewatering the basin. The Rotomite consists of a flotation system, an engine, an hydraulic system, an emergency shutdown system, an operator station, a protective coating, and ancillary equipment. The Rotomite is capable of continuously removing sedimentary deposits from sludge lagoons, ponds, tanks, waterways, etc. The auger/tiller design assures a maximum solid/liquid ratio for centrifugal style dredge pumps and minimal resuspension of solids prior to pumping. The Rotomite is capable of removing sludge deposits up to 40 cm deep and 2.5 m wide in a single pass, and has a cutting depth ranging from 0.3 m above to 5 m below the water surface.

Limitations: Does not handle stringy vegetation.

Type of Power: Diesel/Hydraulic

Government Funding: Superfund

Environmental Concerns: Shrouded cutterhead minimized turbidity.

Health & Safety Plan Available:

Regulatory Approvals Used in USA, Central America, Canada, Korea

Setup/Feed: Mobilization (days): Demobilization (days):

Removal Rate Average (m³/hr): 175

Cost: Capital Cost (US\$): \$110,000.00

Unit Cost (US\$/m³): \$0.00 -

Average Cost (US\$/m³): \$0.50

Developers:

SRS Crisafulli

P.O.B. 1051 (Crisafulli Drive)

Glendive, MT

USA 59330-1051

Notes Home Page: <http://www.crisafulli.com>

Contact: Richards, Carl K.

Phone: (406) 365-3393 Ext:

Fax: (406) 365-2249

Email: srsc@crisafulli.com

Vendors:

SRS Crisafulli

P.O.B. 1051 (Crisafulli Drive)

Glendive, MT

USA 59330-1051

Notes Home Page: <http://www.crisafulli.com>

Contact: Richards, Carl K.

Phone: (406) 365-3393 Ext:

Fax: (406) 365-2249

Email: srsc@crisafulli.com

Literature References:

SRS Crisafulli, Rotomite 180P

20-Jan-98

Project: Rotomite 142P Dredging Demonstration

Year 95

Location: Everett, WA, USA

Bench Scale

Client/Funding Agency	Contact	Phone
City of Everett		

Not Monitored

Removal Rate(m³/hr): 230 Amount Removed In-Situ (m³):

Removal Cost(US\$):

Mobilization (days): Demobilization (days):

Site Conditions: Municipal wastewater treatment sludge & solids

Contaminants Present: Sludge - organic waste
Plastics, textiles

Water Quality:

Turbidity:

Total Suspended Solids:

Percent Solids: 8.2 (average)

Site Containment Used? No Yes

Exceed Set Standards?

Description: Dredge demonstration on site at City of Everett WWTP. Slurry pumped at at rate of up to 230 m³/hr with solids contents ranging from 4% to 11.4% (by weight). Piping system consisted of 40 m, 15 cm aluminum floating flexible discharge pipe and approximately 300 m of 25 cm schedule 40 steel piping.

Project: Rotomite 142P Dredging Demonstration

Year 95

Location: Phelps, NY, USA

Bench Scale

Client/Funding Agency	Contact	Phone

Not Monitored

Removal Rate(m³/hr): 114 Amount Removed In-Situ (m³):

Removal Cost(US\$):

Mobilization (days): Demobilization (days):

Site Conditions: Sand/gravel crushing facility wash basin.

Contaminants Present: Sand - 200 minus mesh

Water Quality:

Turbidity:

Total Suspended Solids:

Percent Solids: 50 (average)

Site Containment Used? No Yes

Exceed Set Standards?

Description: Dredge demonstration on site at sand/gravel crushing facility wash basin. Sediment consisted of 200 minus mesh sand. Flow rates varied from 110 m³/hr to 230 m³/hr with solids content from 25% to 60% (by weight). No piping system was used.

Toa Corporation, High-Density Sludge Transport System Method (TOTRA)

20-Jan-98

TechID: 288

Technology Type:

System Works With:

Development Stage: Commercial

Country Of Origin: Japan

Description:

TOTRA is a transportation method combining a booster (special centrifugal pump) and the pressurized air-sludge-mixture feeding system using compressed air. It was developed by the Toa Corporation for the continuous transportation of large amounts of sludge over a long distance with no added water.

All dredging conditions are centrally monitored and controlled in the operation room. Data such as the amount of excavated sludge, air pressure, and internal pipe pressure are measured and controlled by a computer with CRT.

The TOTRA system was used at five locations in Japan with a dredging capacity of 600 cubic meters per hour and a transporting capacity of 1000 or more meters.

Limitations:

Type of Power: Diesel/Electric

Government Funding:

Environmental Concerns:

Health & Safety Plan Available:

Regulatory Approvals

Setup/Feed: Mobilization (days):

Demobilization (days):

Removal Rate Average (m³/hr): 600

Cost: Capital Cost (US\$):

Unit Cost (US\$/m³): -

Average Cost (US\$/m³): \$20.00

Removal cost average is assuming sludge carried on a ballast ship or similar vessel.

Developers:

Toa Corporation
Engineering Division
Tokyo,102,
Japan
Notes

Contact: Corporate Civil Engineering Dept.,
Phone: 81332625109 Ext:
Fax:
Email:

Vendors:

Toa Corporation
Engineering Division
Tokyo, 102,
Japan
Notes

Contact: Corporate Civil Engineering Dept.,
Phone: 81332625109 Ext:
Fax:
Email:

Literature References:

Author:
Title: No. 13 WODCON Report
Journal: Working Ship, No. 198

Date:

Toa Corporation, IRIS Method

20-Jan-98

TechID: 232

Technology Type: Mechanical

System Works With:

Development Stage: Commercial

Country Of Origin: Japan

Description:

This dredging system is known as the IRIS Method (Integrated high-density sludge-removing impeller system). The airtight rotating-bucket-wheel system is employed as the dredging system to produce digging under normal air conditions. It prevents the entry of excess water and reduces the dispersion of pollution.

The pressurized air-sludge-mixture feeding system is used to prevent the entry of excess water during sludge transportation and substantially reduce the amount of treated excess water.

This system can effectively dredge thin-layer sludge from the surface of the seabed.

Uses: The IRIS system is used to dredge thin-layer (30 cm in thickness) bottom sludge containing large quantities of nutrient salts; which are one of the main causes of the eutrophication in water.

The No. 1 IRIS system can be transported by land. Its dredging capacity depends on the nature of the soil and many obstacles. Toa also manufactures the No. 3 and No. 5 IRIS systems. The average removal rate for the No. 1 system is 80 m³/hour; No. 3 system : 100 m³/hour; No. 5 system : 100 m³/hour.

Limitations:

Type of Power:

Government Funding:

Environmental Concerns:

Health & Safety Plan Available:

Regulatory Approvals

Setup/Feed: Mobilization (days):

Demobilization (days):

Removal Rate Average (m³/hr): 90

Cost:

Capital Cost (US\$):

Unit Cost (US\$/m³): \$30.00 - \$35.00

Average Cost (US\$/m³): \$32.50

The cost varies depending on conditions such as the nature of the soil, obstacles, and the sludge transporting distance. (Removal rate - assuming soil with a 70% to 80% sludge content - 80 - 100 m³/hour).

Developers:

Toa Corporation
Engineering Division
Tokyo, 102,
Japan
Notes

Contact: Corporate Civil Engineering Dept.,
Phone: 81332625109 Ext:
Fax:
Email:

Vendors:

Toa Corporation
Engineering Division
Tokyo, 102,
Japan
Notes

Contact: Corporate Civil Engineering Dept.,
Phone: 81332625109 Ext:
Fax:
Email:

Literature References:

Author:
Title:
Journal: Dredging and Reclamation (Japanese Journal), No. 148
Author:
Title:

Date: Jul 1988

Journal: HEDORO, No. 45

Date: May 1989

Toa Corporation, No. 7 Clean-Up Dredger

20-Jan-98

TechID: 234

Technology Type: Hydraulic

System Works With: Limited Shore Access

Can be used to dredge canals in spite of its large size.

Development Stage: Commercial

Country Of Origin: Japan

Description:

The No. 7 Clean-Up Dredger is equipped with a clean-up-type suction unit featuring a suction inlet designed with a special function making it capable of dredging sludge as it is from the seabed, while minimizing the generation of turbidity with a high sludge content.

Limitations:

Type of Power: Diesel/Electric

Government Funding:

Environmental Concerns:

Health & Safety Plan Available:

Regulatory Approvals

Setup/Feed: Mobilization (days):

Demobilization (days):

Removal Rate Average (m³/hr): 100

Cost:

Capital Cost (US\$):

Unit Cost (US\$/m³): \$25.00 – \$30.00

Average Cost (US\$/m³): \$28.00

This is for a dredging job of approximately 400,000 m³ for soft mud over a sludge transportation distance of 1,500 m. (Removal rate is 200 - 450 m³/hour).

Developers:

Toa Corporation

Machinery & Electric Equipment Department

Tokyo, 102,

Japan

Notes

Contact:

Phone: 81332625109

Ext:

Fax: (813) 239-2144

Email:

Vendors:

Toa Corporation

Engineering Division

Tokyo, 102,

Japan

Notes

Contact: Corporate Civil Engineering Dept.,

Phone: 81332625109

Ext:

Fax:

Email:

Literature References:

Toyo Construction, Floating Pier Reclamation Method

20-Jan-98

TechID: 294

Technology Type:

System Works With:

Development Stage: Commercial

Country Of Origin: Japan

Description:

In this system, two or more connected floating piers are installed in the reclaimed land to carry earth and sand in trucks on the floating piers and dump the load directly onto the land for reclamation.

Reclaimed land can hold a large amount of earth and sand because the volume change for the earth and sand with this system is smaller than that of a system such as the pump-dredging system.

In addition, the location for dumping earth and sand can be changed freely by moving the floating piers, it is possible to create reclaimed land with a uniform soil layer.

The system can be easily disassembled, moved and reassembled. It can be carried into and out of the land for reclamation.

The system is also suitable for earth and sand spreading for surface treatment projects, dumping surplus soil and waste material and earth and sand for reclamation projects.

Limitations:

Type of Power:

Government Funding:

Environmental Concerns:

Health & Safety Plan Available:

Regulatory Approvals

Setup/Feed: Mobilization (days):
Removal Rate Average (m³/hr): 800

Demobilization (days):

Cost: Capital Cost (US\$):
Unit Cost (US\$/m³): - Average Cost (US\$/m³): \$20.00

Unit price for reclamation is approximately \$20.00/m³. (Maximum removal capacity: 10,000 m³/day).

Developers:

Toyo Construction Co. Ltd.
Technical Division, 5th Floor,
Tokyo,
Japan 101 -
Notes

Contact: Corporate Technical Department,
Phone: 81352104831 Ext:
Fax: 81352104840
Email:

Literature References:

- Author: Japan Dredging and Reclamation Engineering Association
Title: Reclamation Method Using the Floating Pier System
Journal: Dredging and Reclamation: Japan Dredging and Reclamation Engineering Association, No. 127, Date: Jan 1986
January 1986.
- Author:
Title: Large-Scale Reclamation Using a Floating Pier
Journal: Journal of Japan Society of Civil Engineers Date: May 1987
- Author: Japan Dredging and Reclamation Engineering Association
Title: Reclamation of Haneda Off Using the Floating Pier Reclamation Method
Journal: Dredging and Reclamation: Japan Dredging and Reclamation Engineering Association, No. 144, Date: Nov 1988
Nov. 1988

Toyo Construction, Oozer-Pump Dredging Method

20-Jan-98

TechID: 297

Technology Type: Hydraulic

System Works With:

Development Stage: Commercial

Country Of Origin: Japan

Description:

The oozer-pump is designed to reduce the pressure inside the pump, causing high-density sludge to be sucked through the suction inlet by water pressure and atmospheric pressure.

The sludge in the pump is then discharged by compressed air.

The two tanks alternately suck in and discharge sludge, continuously performing high-density sludge dredging.

The oozer pump makes it possible to dredge thin-layer, high-density bottom sludge.

The oozer pump's performance has been proven in a number of dredging projects, including the Minamata Port dredging project of 1983, the Kasumigaseki bottom-sludge dredging project of 1992, and the Barato river sludge dredging project.

This method was awarded the Technology Evaluation Certificate for "High Density Sludge Dredging and Discharging Method" by the Ministry of Transport in March 1993.

Limitations:

Type of Power:

Government Funding:

Environmental Concerns:

Health & Safety Plan Available:

Regulatory Approvals

Setup/Feed: Mobilization (days):

Demobilization (days):

Removal Rate Average (m³/hr):

Cost:

Capital Cost (US\$):

Unit Cost (US\$/m³): \$30.00 - \$50.00

Average Cost (US\$/m³): \$40.00

The unit price is subject to change depending on dredging conditions such as the nature of the bottom sludge, the sludge discharge distance, water depth, and the scale of the work to be performed.

Developers:

Toyo Construction Co. Ltd.

Technical Development Division, 5th floor,

Tokyo,

Japan 101 -

Notes

Contact: Corporate Engineering Department,

Phone: 81352104831 Ext:

Fax: 81352104840

Email:

Vendors:

Toyo Construction Co. Ltd.

Technical Development Division, 5th floor,

Tokyo,

Japan 101 -

Notes

Contact: Corporate Engineering Department,

Phone: 81352104831 Ext:

Fax: 81352104840

Email:

Literature References:

Author:

Title: Removal Work of Organic Deposit by Oozer Pump Dredger

Journal: 12th US/Japan Experts Meeting on Management of Bottom Sediments Containing Toxic Substances

Date: Nov 1986

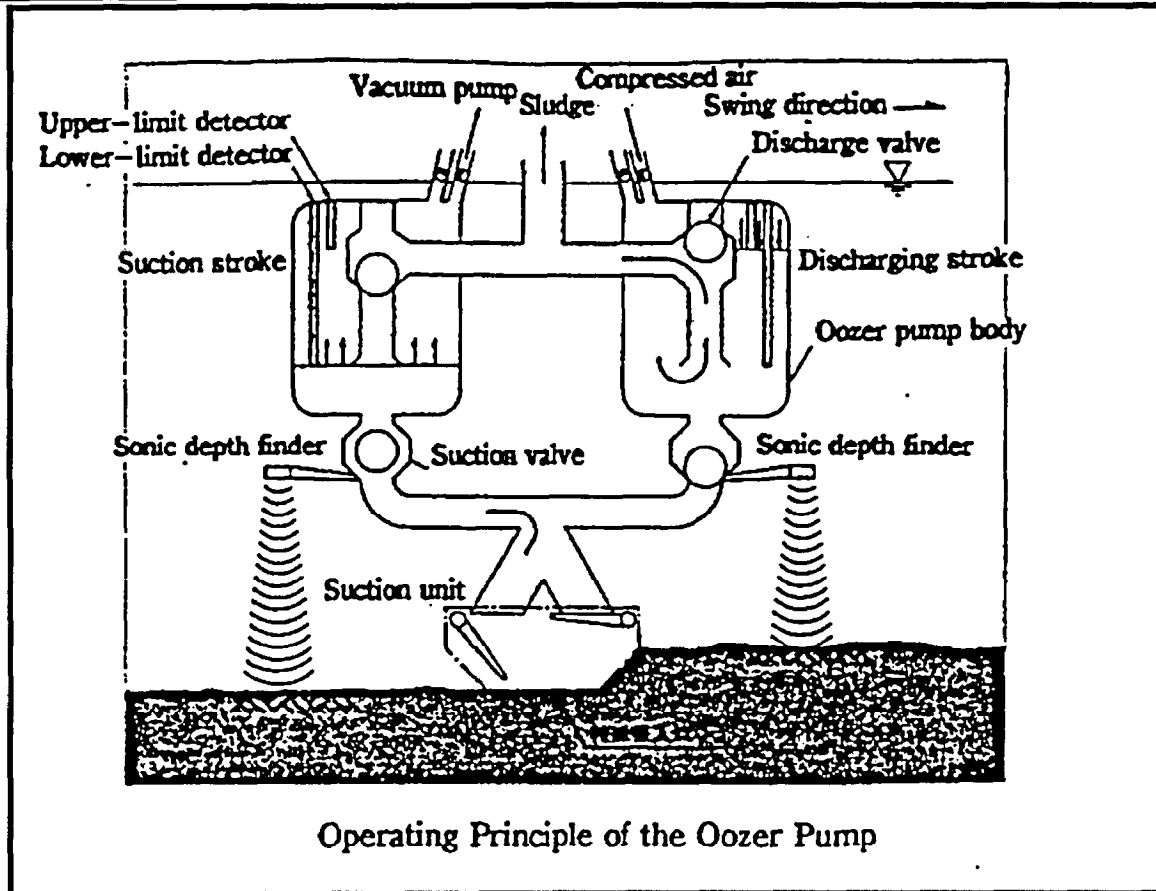

Wakachiku Construction, "No. 2 Clean Sweeper" High-Density Sludge Dredger

20-Jan-98

TechID: 251

Technology Type: Hydraulic

System Works With:

Development Stage: Full Scale Demo

Country Of Origin: Japan

Description:

The head assembly is covered by an airtight hood to keep it under normal air conditions for dredging the sludge with the scraping rotor.

The special dredging mechanism enables the dredging and transportation of high-density (up to 80% of the sludge content) and low-turbidity. As the No. 2 Clean Sweeper is a portable type dredger that can be disassembled and reassembled easily, this can be applied even for small rivers and lakes.

Little excess water treatment is required because the dredged soil is of a very high density (70% to 80%). The dredged surface can be made level. Almost no turbidity occurs in the area. Assembly and disassembly of the dredger is also simple and easy.

Limitations:

Type of Power:

Government Funding:

Environmental Concerns:

Health & Safety Plan Available:

Regulatory Approvals

Setup/Feed: Mobilization (days):

Demobilization (days):

Removal Rate Average (m³/hr):

Cost:

Capital Cost (US\$):

Unit Cost (US\$/m³):

\$30.00 - \$40.00

Average Cost (US\$/m³): \$35.00

Assuming sludge transportation distance of 1,500 m; dredging amount of 100,000 m³. Excludes costs for transportation, discharge pipes, and reclamation and embanking works.

Developers:

Wakachiku Construction Co. Ltd

Engineering Division

Tokyo, 153,

Japan

Notes

Contact: Corporate Civil Engineering Dept.,

Phone: 81334920681

Ext:

Fax: 81334920681

Email:

Vendors:

Wakachiku Construction Co. Ltd

Engineering Division

Tokyo, 153,

Japan

Notes

Contact: Corporate Civil Engineering Dept.,

Phone: 81334920681

Ext:

Fax: 81334920681

Email:

Literature References:

Wartsila Scraping Dredger

20-Jan-98

TechID: 257

Technology Type: Mechanical**System Works With:****Development Stage:** Commercial**Country Of Origin:** Finland**Description:**

The operating principle of the Wartsila scraping dredger is very simple, based on a tiltable cargo box, loaded and emptied by means of a mechanical scraper.

The Wartsila scraping dredger has successfully completed traditional dredging jobs as well as removing materials like stones, logs, underwater garbage and contaminated soil. It has also proved useful for digging away dry soil from banks and shorelines.

The scraping dredger can be delivered in various sizes equipped according to your own specifications and special needs.

Limitations:**Type of Power:****Government Funding:****Environmental Concerns:****Health & Safety Plan Available:** **Regulatory Approvals****Setup/Feed:** Mobilization (days):

Demobilization (days):

Removal Rate Average (m³/hr): 150**Cost:** Capital Cost (US\$):Unit Cost (US\$/m³):

-

Average Cost (US\$/m³):**Developers:**

Kvaerner Masa-Yards
Turku New Shipyard
Turku,
Finland
Notes

Contact: Torma, Matti

Phone: 358212667190

Ext:

Fax: 358212666999

Email:

Literature References:

Youngsman, Weed and Sedimentation Removal

20-Jan-98

TechID: 338

Technology Type: Hydraulic, Fluidization

System Works With: Debris, Water Depth 2-10m, Limited Shore Access, Water Depth < 2m, Water Depth > 10m

Development Stage: Commercial

Country Of Origin: USA

Description:

Liquifaction of bottom sediments to reduce root mass allowing transport of vegetation by hydraulic pipeline to disposal over agricultural/forest lands at a distance in excess of 8 km. .

Limitations:

Type of Power: Diesel or Electric

Government Funding:

Environmental Concerns:

Health & Safety Plan Available:

Regulatory Approvals

Setup/Feed: Mobilization (days):

Demobilization (days):

Removal Rate Average (m³/hr):

Cost:

Capital Cost (US\$):

Unit Cost (US\$/m³):

-

Average Cost (US\$/m³):

Developers:

Marine Construction and Dredging Inc.

113 Lummi Drive

LaConner, WA

USA

98257-

Notes

Contact: Youngsman, Ken

Phone: (360) 466-4672

Ext:

Fax: (360) 466-8849

Email:

Vendors:

Marine Construction and Dredging Inc.

113 Lummi Drive

LaConner, WA

USA

98257-

Notes

Contact: Youngsman, Ken

Phone: (360) 466-4672

Ext:

Fax: (360) 466-8849

Email:

Literature References:

Additional copies of this report can be obtained from the
National Shipbuilding Research and Documentation Center:

<http://www.nsnet.com/docctr/>

Documentation Center
The University of Michigan
Transportation Research Institute
Marine Systems Division
2901 Baxter Road
Ann Arbor, MI 48109-2150

Phone: 734-763-2465
Fax: 734-763-4862
E-mail: Doc.Center@umich.edu