

UMTRI-72709

INFORMATION CENTER

HIGHWAY SAFETY RESEARCH INSTITUTE
INSTITUTE OF SCIENCE AND TECHNOLOGY
THE UNIVERSITY OF MICHIGAN

4 0214

Revised August 1985

THE NATIONAL SHIPBUILDING RESEARCH PROGRAM

**Process Analysis
Via Accuracy Control**

U.S. DEPARTMENT OF TRANSPORTATION
Maritime Administration
in cooperation with
Todd Pacific Shipyards Corporation

**Transportation
Research Institute**

Report Documentation Page

*Form Approved
OMB No. 0704-0188*

Public reporting burden for the collection of information is estimated to average 1 hour per response, including the time for reviewing instructions, searching existing data sources, gathering and maintaining the data needed, and completing and reviewing the collection of information. Send comments regarding this burden estimate or any other aspect of this collection of information, including suggestions for reducing this burden, to Washington Headquarters Services, Directorate for Information Operations and Reports, 1215 Jefferson Davis Highway, Suite 1204, Arlington VA 22202-4302. Respondents should be aware that notwithstanding any other provision of law, no person shall be subject to a penalty for failing to comply with a collection of information if it does not display a currently valid OMB control number.

1. REPORT DATE AUG 1985	2. REPORT TYPE N/A	3. DATES COVERED -			
4. TITLE AND SUBTITLE The National Shipbuilding Research Program Process Analysis Via Accuracy Control		5a. CONTRACT NUMBER			
		5b. GRANT NUMBER			
		5c. PROGRAM ELEMENT NUMBER			
6. AUTHOR(S)		5d. PROJECT NUMBER			
		5e. TASK NUMBER			
		5f. WORK UNIT NUMBER			
7. PERFORMING ORGANIZATION NAME(S) AND ADDRESS(ES) Naval Surface Warfare Center CD Code 2230 - Design Integration Tools Building 192 Room 128 9500 MacArthur Bldg Bethesda, MD 20817-5700		8. PERFORMING ORGANIZATION REPORT NUMBER			
9. SPONSORING/MONITORING AGENCY NAME(S) AND ADDRESS(ES)		10. SPONSOR/MONITOR'S ACRONYM(S)			
		11. SPONSOR/MONITOR'S REPORT NUMBER(S)			
12. DISTRIBUTION/AVAILABILITY STATEMENT Approved for public release, distribution unlimited					
13. SUPPLEMENTARY NOTES					
14. ABSTRACT					
15. SUBJECT TERMS					
16. SECURITY CLASSIFICATION OF:			17. LIMITATION OF ABSTRACT		
a. REPORT unclassified	b. ABSTRACT unclassified	c. THIS PAGE unclassified	SAR	18. NUMBER OF PAGES 123	19a. NAME OF RESPONSIBLE PERSON

UMTRI

72789

FOREWORD

Since the original edition of this publication was issued in 1982, most U.S. shipbuilders accepted the idea that appreciable productivity gains can be obtained by more in-process accuracy and are responding accordingly. More importantly, some also accepted statistical control of accuracy variations as the most effective technique for control of work and for *constantly* improving productivity. They have responded with significant investments, e.g., assigning college-educated people as Accuracy Control (A/C) engineers and creating prerequisite databases.

In addition, the 1984 report, "Toward More Productive Naval Shipbuilding: issued by the Marine Board, National Research Council, related A/C to military requirements, i.e., abilities to withstand high-impact shock and great submergence depths.

To further support the A/C movement, the original issue of the publication has become the text for courses in shipbuilding curriculums at the Universities of Michigan and Washington. It serves further to indoctrinate both beginning and mid-career people at the U.S. Navy's Engineering Duty Officer School.

All of the foregoing created need for more in depth understanding of A/C which this revision attempts to fulfill. Description of pertinent statistical theory has been made more comprehensive. Use of the same principals which are the basis for Statistical Quality Control, as advocated by Dr. W. Edwards Deming, is emphasized. A section has been added on start-up which is based on actual experiences in U.S. shipyards. Also, this edition describes how a constantly improving manufacturing system operates by providing an analytical basis without which Quality Circles are ineffective.

**Transportation
Research Institute**

ACKNOWLEDGEMENTS

The material on which this publication was originally based was compiled by a project team led by S. Nakanishi, International Division, Ishikawajima-Harima Heavy Industries Co., Ltd. (II-II) of Japan. Team members included K. Ando and M. Hatake. Their participation was managed by Y. Ichinose of IHI Marine Technology, Inc., New York City.

The editor and contributing author of the original edition, February 1982, was L. D. Chirillo who assists the Los Angeles Division of Todd Pacific Shipyards Corporation in management of research projects. He was assisted by R. D. Chirillo and R. L. Storch of L. D. Chirillo Associates and the University of Washington, respectively.

This revision was prepared by R. L. Storch with a number of passages added by L. D. Chirillo. It is an end product of one of the many projects managed and cost shared by Todd for the Maritime Administration created National Shipbuilding Research Program. The objective, described by Panel SP-2 of the Ship Production Committee of the Society of Naval Architects and Marine Engineers, is to improve productivity.

TABLE OF CONTENTS

1.0	Introduction	1
1.1	General	1
1.2	Basic Statistical Principles	3
1.2.1	Control Charts	5
1.2.2	Variation Merging	7
1.2.3	Acceptance Sampling	8
2.0	Approach	9
2.1	Overview	9
2.2	Start-up	13
3.0	Planning	15
3.1	Preliminary Planning	15
3.2	Detail Planning	15
3.3	Standardization	19
3.3.1	Work Standards	19
3.3.2	Accuracy Standards	22
4.0	Executing	23
4.1	Self Check	23
4.2	A/C Group	23
4.3	When and What to Check	23
4.4	Information for Check Sheets	23
4.4.1	Part Fabrication	26
4.4.2	Sub-block Assembly	26
4.4.3	Block Assembly	26
4.4.4	Hull Erection	27
5.0	Evaluating	29
5.1	Regular Analysis	29
5.1.1	Significance of Mean Value	31
5.1.2	Significance of Standard Deviation	31
5.1.3	Setting Accuracy Standards	31
5.1.4	Modifying Distributions	32
5.1.5	Sequence for Analysis	36
5.2	Urgent Analysis	36
5.3	Control	39
5.4	Process Analysis	44

6.0	Suggestions	45
6.1	Design	45
6.2	Mold Loft	45
6.3	Production Control	45
6.4	Fabrication	47
6.5	Sub-block Assembly	47
6.6	Block Assembly	48
6.7	Standardization	48
6.8	Accuracy Standards	48
6.9	Excess and Shrinkage Allowance Standards	48
6.9.1	Elements of Shrinkage Allowance	48
6.9.2	Ways to Distribute Excess	48
6.9.3	Ways to Distribute Excess vs. Assembly Sequences	49
6.9.4	Standards for Work Processes and Information Flow	49
6.10	Measuring	50
6.11	Photographs of Accuracy Control Practices	50

Appendix A — Planning Vital Points for a Bulk Carrier

Appendix B — Statistical Concepts in Accuracy Control

Appendix C — Variation Merging Equations

Appendix D — Samples of an Industry's and a Shipyard's Accuracy Standards

Appendix E — Analysis of Shrinkage in a Double-bottom Floor

Appendix F — Control Charts



EX SCENTLA EFFICIENS

**Sketch Only Reprinted by Permission; Copyright © 1981 U.S. Naval Institute*

*This book is dedicated to the memory of
a shipbuilder
from New Orleans, Louisiana*

*Sigmund A. Sohzres
November 14,1933 – May 31,1985*

1.0 INTRODUCTION

1.1 General

Effective shipbuilders accomplish in-house, only work which by nature and volume can be performed in accordance with the concept of Group Technology (GT). Parts, subassemblies and assemblies, i.e., interim products, needed for an end product, are classified by the problems inherent in their manufacture. Thus, regardless of differences in designs and quantities required, interim products are manufactured on dedicated production lines, i.e., process flows. A main flow, such as for producing a hull block, is supported by coordinated subordinate flows such as one for producing sub-blocks.

With such dependencies, a control system is required to monitor accuracy in order to avoid delays and rework, particularly when blocks are joined together in a building dock during hull erection. However, accuracy control (A/C) having a statistical basis does considerably more. A/C involves the regulation of accuracy as a management technique for constantly improving productivity of an entire manufacturing system. A/C is the scientific means which the world's leading shipbuilders employ for *constantly* identifying and prioritizing the problems which must be addressed to obtain the greatest rates of productivity improvement. The statistical basis makes clear the relationship between cause and effect. As Dr. W. Edwards Deming teaches, *the obligation to improve the system never ceases*.

Statistics is the branch of mathematics dealing with collection, analysis, interpretation and presentation of masses of numerical data. The methods of statistics are methods of applied mathematics. Shipbuilding engineers who manage A/C programs must at least understand college-level elementary statistics.

Other prerequisites pertain to the data needed. An A/C data base is a major investment. At first it requires systematic recording of thousands of measurements. Such efforts are expensive. They will deter traditional managers having short-term goals. These people are more likely to apply what they believe to be A/C as sporadic and unsophisticated preventive steps in response to one particular customer's requirement for a specific degree of accuracy.

Lack of long-term application negates the central importance of statistically-valid data which describes a shipyard's *normal* accuracy performances. Such data are the basis for continuing the collection of measurements by mathematically determined sampling and for continued analysis and interpretation.

Effective shipbuilders regard their A/C data base as a capital investment and means of production every bit as 'indispensable as a crane or a building dock. The significant cost for starting an A/C program makes sense only when it is amortized over future

projects just as any other large capital investment. Costs for continuing the collection of data as a normal part of a production process, are nominal because of the sampling techniques employed.

A/C cannot be effectively applied in the absence of *product-oriented work breakdown structure (PWBS)* which features interim products (i.e., fabricated parts and various subassemblies) classified by the *problem areas* their manufacture imposes. This is the singular means used by the world's most effective shipbuilders to operate both real and virtual work flow lanes for a high variety of objects in mixed quantities.

Because the different interim-products are classified by common problem areas, the same work situations are sufficiently repeated within each area for statistical treatment. Moreover, as sets of solutions, e.g., specific classes of worker skill and facilities, we matched to problem areas, WC data are unaffected by variations that would otherwise occur.

A final prerequisite for successful implementation of A/C for hull construction, is the application of line heating for accurately curving and/or twisting plates and structural shapes such as needed for regions of a hull that are curved. The need for accuracy is critical in order to eliminate or at least minimize the use of mechanical force when fitting components. When force is used, as with traditional shipfitting methods, structures develop locked-in stresses and, following welding, distortion that is neither predictable nor repeatable. A/C measurements and data are meaningless in such circumstances and productivity is inherently limited regardless of degrees of experience possessed by workers and their supervisors. Line heating by itself and also in conjunction with benders, presses and rollers, permits curvatures to be achieved with sufficient accuracy to eliminate or minimize force fitting.¹

Thus, the major prerequisites for successful implementation of A/C for hull construction are:

- adoption of a product oriented work breakdown structure to establish repeatable (standard) work processes regardless of interim-product design differences,
- use of line heating for accurately shaping parts so as to eliminate or minimize distortion after welding, and
- collection of an A/C data base describing a shipyard's normal accuracy performances.

All three inextricably link accuracy and productivity.

1. See "Product Work Breakdown Structure-Revised December 1982" National Shipbuilding Research program OWRP).

2. See "Line Heating - November 1982" NSRP.

Some product-oriented shipbuilders evaluate each proposed interim product or a lot consisting of more than one, for its efficiency as a work package. **Productivity Value (PV)** is expressed by the formula

$$PV = f(T,N,Q)$$

where:

T= time allowed for its accomplishment,

N= number of units of resources, and

Q= quality of work environment and *accuracy specified for the interim product.*

The function (T,N,Q) is determined empirically and separately for each stage within each flow lane. Each necessarily considers the immediately preceding and following work stages.

Having PV vary directly with Q insofar as it applies to *accuracy specified for the interim product seems* to be a paradox. However, in this case Q relates to the efficiency of the tolerances specified with subsequent assembly work in mind. Are the tolerances too accurate? Are they accurate enough? AIC provides the method of determining the optimum tolerances required at each stage consistent with the needs of customers, regulatory societies *and productivity.*

When unprecedented projects are contemplated, A/C provides means for predicting how current work processes will perform. When predicted productivity is not sufficient, managers can determine the effects of changed design details, work sequences, and, if necessary, work processes, *before work starts.*

AIC is a repeating cycle of *plan, execute, evaluate and replan*; Figure 1-L Vhal points and dimensions for blocks, sub-blocks and parts that are needed to assure accuracy of an end product are identified. They are systematically monitored at designated production stages. Similarly, many other measurements are made and carefully documented until scientifically valid samples of accuracy data have been collected. The data are evaluated using statistical methods *to verify performance* in terms of *standard ranges* of accuracy normally encountered and *tolerance limits* beyond which rework is required. By including such written requirements in work instructions and by systematically monitoring, A/C “tightens up” all activities along a production line, e.g., template production, marking, cutting, bending, fitting, welding, and line heating so that the tolerance requirements for each are compatible with the others’. No longer are crucial judgments about accuracy left to opinions and guesses.

A specific example of “tightening up” for a particular work process was further development of line heating to *more accurately* form curved hull-parts as a means of minimizing erection work. Man-hours required for bending were reduced to almost one third those needed for conventional rolling or pressing; fewer clips, dogs, wedges, etc. were required by assembly workers; and rework for adjusting joint gaps during hull erection was greatly reduced.

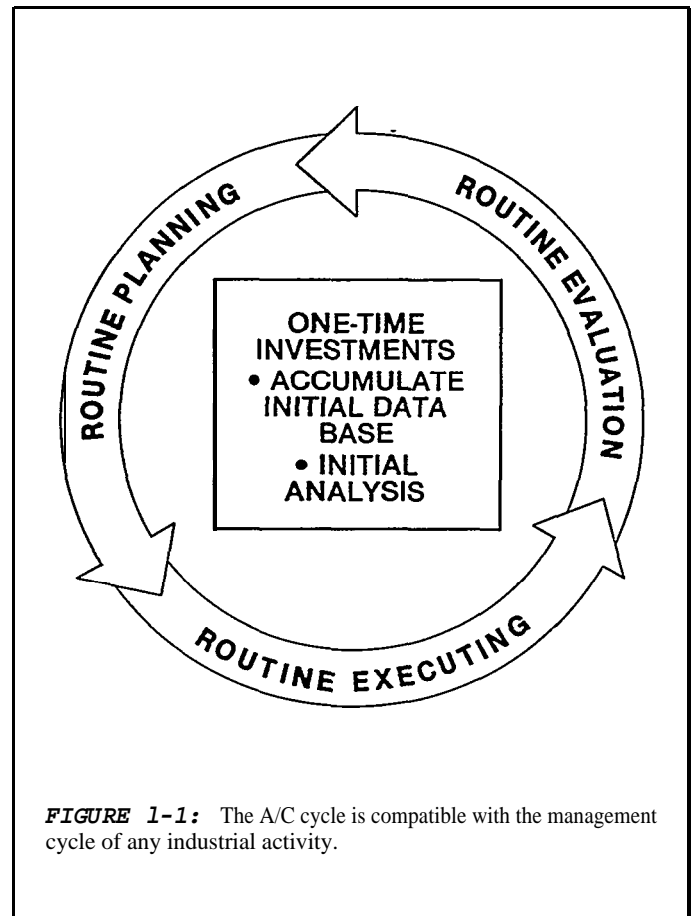
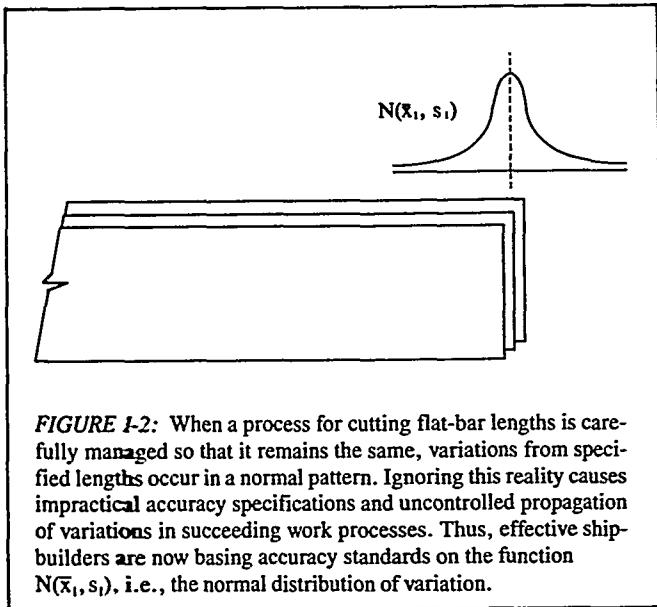

FIGURE 1-1: The A/C cycle is compatible with the management cycle of any industrial activity.

Where most effectively applied, A/C engineers are assigned throughout the *operations* department. Because their methods are *analytical* and always address the *entire shipbuilding process* their recommendations are inherently apolitical. Thus, they have the best opportunities for developing themselves as *shipbuilding engineers*. As A/C experience is virtually prerequisite for higher managerial jobs, candidates are carefully selected from people having about eight years shipbuilding experience and memberships are rotated. This viable group, in addition to its day-to-day planning, executing and evaluating, functions as a defacto staff, i.e., advisory group, to the operations manager and his deputies even though they are assigned to different departments at all managerial levels, including shops.

A/C provides scientifically derived, written and realistically obtainable accuracy standards and goals. A/C is a function that transcends departmental responsibilities. Whether it should be adopted should not be left to department or shop managers whose concerns are parochial.

A/C reports contain essential and reliable data that measure critical aspects of production performance and indicate where improvements are required. Quite apart from controlling accuracy, A/C also defines management options regarding *all* aspects of an operations organization. Implementation requires total management commitment. In each shipyard, A/C should significantly preoccupy the most senior operations manager.



1.2 Basic Statistical Principles

Statistical analysis as applied for A/C is based upon the observation that there is no such thing as absolute accuracy. No matter how precise workers try to be during a specific process, variations from specified dimensions are always measurable. Thus, accuracy exists only in terms of usually achieved ranges. Working with ranges of variation is crucial for production control and for achieving specified end-product accuracy. The distinction between variation and error is very important.

Errors are acts that through ignorance, deficiency or accident, cause departures from normal work performance. They should not ordinarily occur. A/C deals with variations that occur in the course of normal operations.³

Variations in a work process are a result of all influences, e.g., workers, machines, tools, materials, and procedures. Variations are attributed to either *special* or *common* causes. Special causes are not common to the process. Special causes of variation are specific to a certain worker or machine. They represent a departure from normal conditions and performances. In other words, special means a disturbance from outside management's system. Special causes should be identified and removed as a regular part of monitoring a work process. They can often be identified and corrected by the work force.

Unacceptable variations that are due to common causes are indicative of work process capabilities and can only be altered by changing the work processes. *Common cause variations are the responsibility of management.* The eminent statisticians, W. Edwards Deming and J. M. Juran agree, that of all problems encountered in manufacturing, common causes outnumber special causes by a ratio of about five to one.

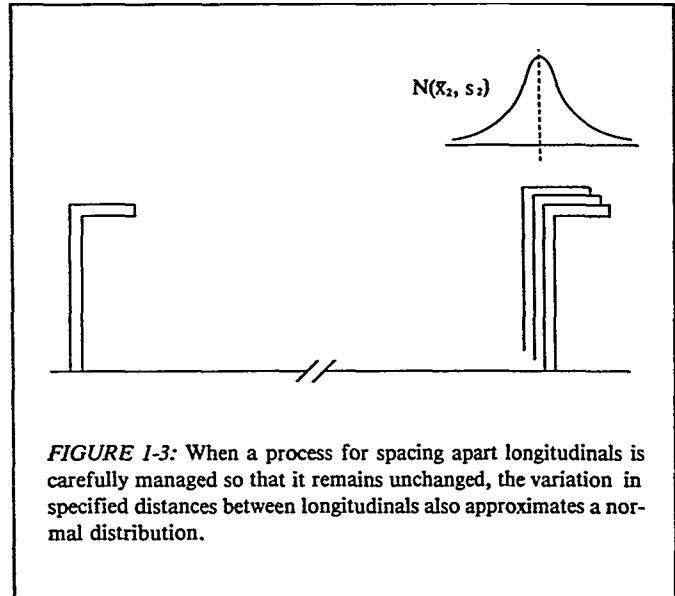

How to measure variation is the key to production control. Statistics is the branch of mathematics that deals with the description and interpretation of variation. Simple arithmetic is not sufficient.

Any repeatable work process (consistent in facilities and worker skills) produces products that have variations in characteristics. For example, even something as simple as parts which are cut lengths of flat bar will exhibit variations from design dimensions. The variations, when plotted by the number of times they occur, will approximate a normal distribution; Figure 1-2. Two parameters describe the relative shape of a normal distribution (N). They are:

- mean, \bar{x} , the arithmetical average of variations in a sample, which describes the central tendency of the distribution, and
- standard deviation, s , which classes the sizes of variations from the mean value by their frequencies of occurrence, and thus is a measure of the relative scatter of points around the mean.⁴

For a normal distribution, 68% of the values fall within one standard deviation of the mean, 95% fall within two standard deviations, and 99.7% fall within three standard deviations. Both parameters are obtainable from mathematical formulas.

Similar considerations can be applied to each work process. Thus, spacings between longitudinals will also vary, and another normal distribution having its own mean value and standard deviation applies; see Figure 1-3. Whether the variations in both flat-bar lengths and longitudinal spacings impose requirements for rework, depends upon their merger during a later assembly process.

³For further discussion of variation and error, see "On Some Statistical Aids Toward Economic Production," by W. Edwards Deming, *Interfaces*, Vol. 5, No. 4, August 1975.

⁴Note that in the remainder of this chapter, discussion centers on sampling from normal distributions. The distribution of samples from a normally distributed population is described by the sample mean, \bar{x} , and the sample's standard deviation, s , as described above. The normally distributed population from which the samples are drawn, is also described by a mean and standard deviation, but these population parameters are commonly denoted by μ and σ , respectively.

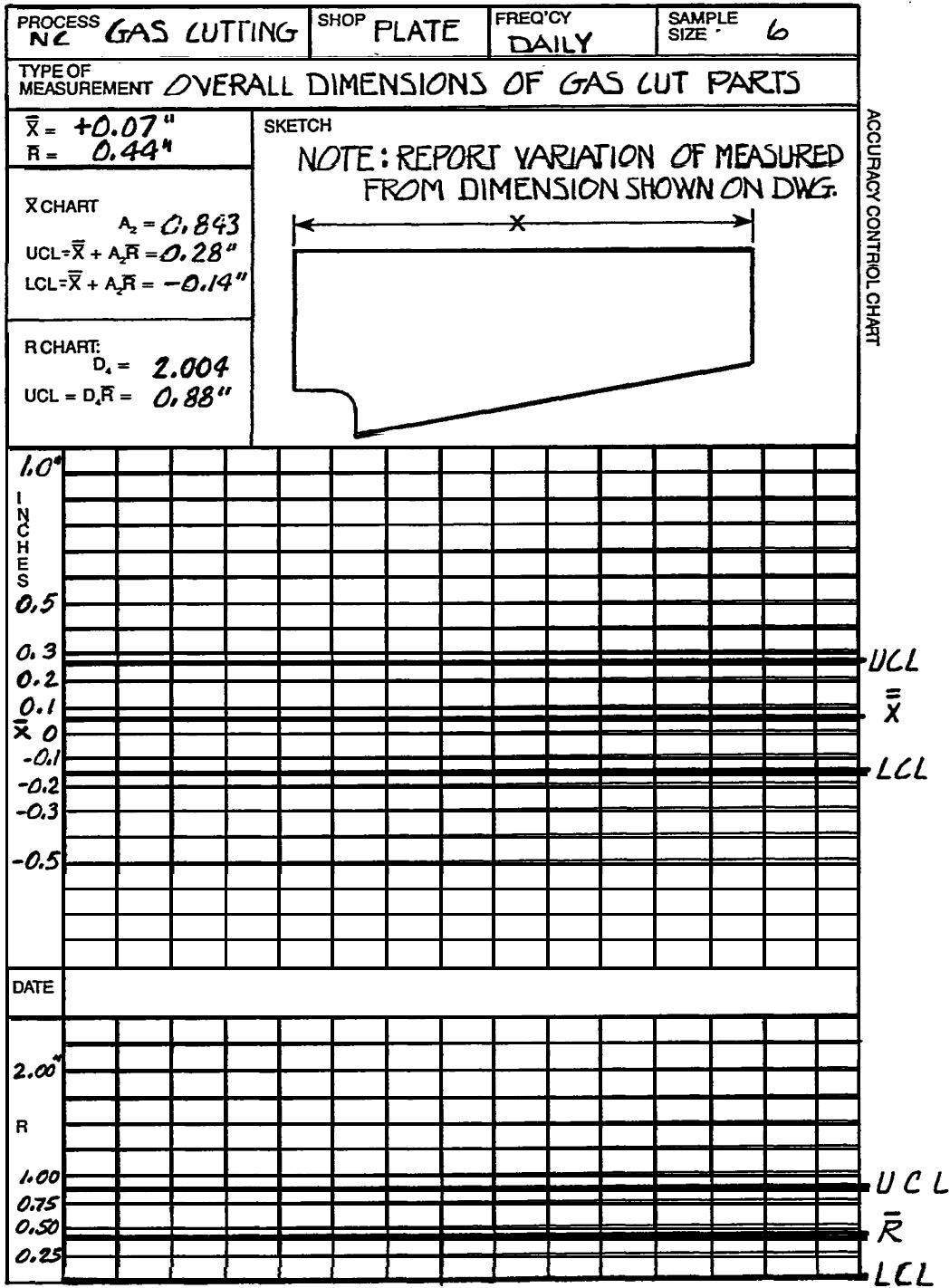

FIGURE 1-4: Example of an X and R Control Chart.

1.2.1. Control Charts

The most common tool used in statistical quality control is the Shewhart *control chart* which was first described in 1924. Control charts apply the concept of expected and measurable variation in work processes, and are used to distinguish between common and special causes. When only common cause variations are detected, the process is operating normally. Should special cause variations be found, however, investigation and identification of these causes is required in order to eliminate them and return the process to normal performance.

The control charts, each a related set of one \bar{x} and one R chart, are plots of the mean (\bar{x}) and range (R) of random samples of measurements from a specific work process over time; see Figure 14. Like standard deviation, the R for a random sample is a measure of scatter. R is the difference between the largest and smallest value in the sample. Although it is a less rigorous measure of variability than the standard deviation, its simplicity has led to its widespread use in control charts.

Control chart theory is based on the statistical *central limit theorem*. The theorem states that the distribution of the means of random samples, taken from a normal distribution, is another normal distribution with the same mean as the original distribution, and a standard deviation equal to the standard deviation of the original distribution divided by the squareroot of the random sample size; see Figure 1-5. This result can be used to detect changes in the original distribution, which would indicate the presence of special causes of variation.

The technique involves initially determining regular performance for a work process (i.e., its normal distribution), using a large data sample. This normal performance can be used to establish an expected range of variation for the process. Subsequent random samples of products from the work process can then be monitored to detect changes in the performance of the process. Control charts establish limits on the variation of the mean and range of these random samples. The limits are commonly set three standard deviations above and below the process mean and average range. Three standard deviation limits are used because they provide 99.7% assurance that exceeding these limits is the result of a change in the normal distribution of the process and therefore the result of a special cause. Data such as those shown in Figure 1-6 are used to determine individual entries to an \bar{x} and an R chart.

The control charts provide information about a particular work process. Since some variation is a regular result of any work process, it is important to be able to distinguish between expected change or random variations, and other variations. Thus the control charts are also used to assure that action need not be taken to maintain the usually achieved accuracies of work processes.

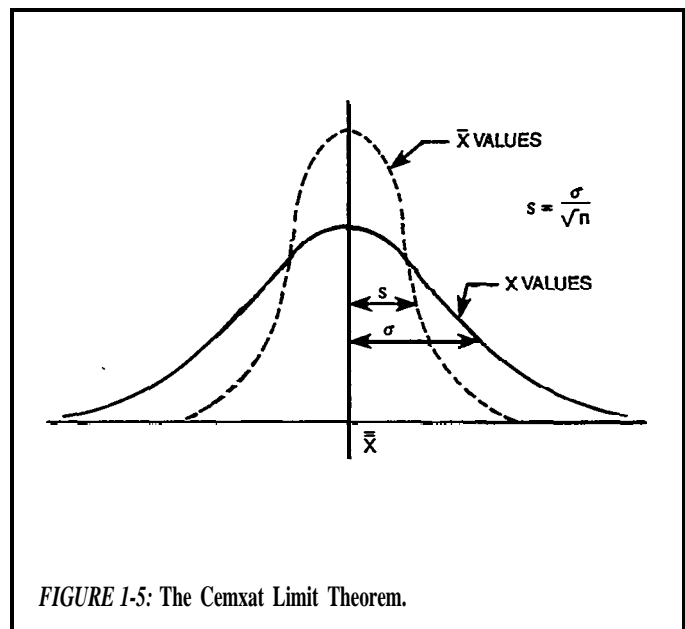

FIGURE 1-5: The Central Limit Theorem.

Control charts are developed for a work process when the process is in a state of *statistical control*. Some understanding of the meaning of statistical control is important. A state of statistical control is a state of randomness. When a process is in control and no special causes are present, variations on the \bar{x} and R charts are due to common causes. Points plotted on the \bar{x} and R charts will fall within the control limits. When points fall outside the control limits, they indicate the presence of a special cause of variation. The production worker can almost always detect and correct these causes. When in a state of statistical control, a work process has predictable and repeatable outputs. Thus, a state of statistical control is evidenced by random sample values of \bar{x} and R falling within the control limits on control charts. The control limits and the sample size indicate the level of accuracy and the variation that can be expected.

Sound understanding of statistical control is essential to management. . . . Stability, or the existence of a system, is seldom a natural state. It is an achievement, the result of eliminating special causes one by one on statistical signal, leaving only the random variation of a stable process.

In developing \bar{x} and R control charts, six values are required, i.e., the centerline, upper control limit and lower control limit for each chart; see Figure 1-4. For each work process, the \bar{x} and R charts are based on an established and repeated sampling procedure. The sampling procedure includes a specified sample size, n . The control chart values are determined from the results of a series of random samples.

DESIGN NAME TAGOS	HULL NO. 1,2	PLATE THK. 5/16"	NAME jrg	DATE 1/30/83
PROCESS NC GAS CUTTING	STAGE OF CONSTR. PARTS	MEASUREMENT DESCRIPTION OVERALL DIMENSION		

	PART NO.	MEASURED		DIM. AS MEAS'D. (A)	TARGET DIM. (T)	Variation (X-T)	NOTES
		FROM	TO				
1	TA1000004	a	b	192.56	192.69	-0.13	Tunnel flat
2		c	d	192.56	192.69	-0.13	} Hull #1
3		a	c	59.87	59.84	+0.03	
4		b	d	59.87	59.84	+0.03	
5	TA1000047	a	d	47.63	47.84	-0.21	
6	TA1000046	FWD EDGE	AFT EDGE	192.75	192.69	+0.06	long'l bnd on Q - Hull #2
12							

$X_{min} = -0.21$
 $X_{max} = +0.06$
 $\Sigma X = -0.35$

FORMULAS:
 $\bar{X} = \frac{\Sigma X}{N}$
 $R = X_{max} - X_{min}$

sample size N = 6
 avg. variation $\bar{X} = -0.06$
 range R = 0.27 in.

FIGURE 1-6: Typical Data Collection Sheet for preparation of an \bar{x} and R Control Chart.

If k samples of size n are taken, the \bar{x} chart values are:

$$CL = \bar{\bar{x}} = \frac{\Sigma \bar{x}}{k} = \frac{\Sigma x}{nk}$$

$$UCL = \bar{\bar{x}} + A_2 \bar{R}$$

$$LCL = \bar{\bar{x}} - A_2 \bar{R}$$

and the R chart values are:

$$CL = \bar{R} = \frac{\Sigma R}{k}$$

$$UCL = D_4 \bar{R}$$

$$LCL = D_3 \bar{R}$$

The constants, A_2 , D_3 and D_4 are commonly available in listings of statistical constants and are functions of sample size, n.

In Japan, where this statistical approach was first applied throughout industry, an interesting thing happened. Management began to furnish supervisors and workers with meaningful

and reliable indicators of how work processes perform. For the first time sensitive barometers existed indicating the results of influences on work processes. Control charts, conspicuously posted, were clearly disclosing that most problems encountered were due to causes common to managements' systems.⁶

No longer being blamed for problems they could do nothing about, spontaneously, supervisors and workers began to discuss and suggest how to make improvements. Correctly identifying the positive reaction as a characteristic of human nature, managers responded by teaching supervisors and workers basic analysis techniques involving Pareto diagrams and Ishikawa (cause and effect) diagrams that enhance abilities to constantly identify and solve problems. Thus, the birth of *real* quality circles in Japan, was a natural consequence of statistical methods.⁷

*Most Japanese managers know that the establishment of Quality Circles is not the first but the last step in building a corporate system that will support a company's total commitment to product quality and productivity.*⁸

So conceived and sustained with a sound analytical basis, quality circles are real tools for *constantly* improving a manufacturing system.

⁶Richard D. Chirillo, "Analytical Quality Circles," for the University of Washington Ship Production Technology Course, 3 October 1983.

⁷The spontaneous nature of responses by supervisors and workers is widely reported by W. Edwards Deming. For descriptions, in English, of the analysis techniques that many Japanese managers taught their workers, see "Guide to Quality Control," by Dr. Kaoru Ishikawa, Asian Productivity Organization, Aoyama Dai-ichi Mansions, 4-14 Akasaka 8-chome, Minato-ku, Tokyo 107, Japan, Second Revised Edition 1982 (ISBN-92-833-1036-5).

⁸Dr. Y. Tsurumi, The Dial, September 1981.

1.2.2 Variation Merging

Ships are built by procuring or fabricating parts and then joining them to create subassemblies. In turn, these are combined through several manufacturing levels to produce increasingly larger subassemblies, blocks and ultimately a complete ship. Production line techniques are employed by the many different interim products required.

When each of a succession of work processes is in statistical control, its normal distribution of variations (mean and standard deviation) can be determined. With such data, it is possible to predict, statistically, the merged variation from the total series of work processes.

Consider the combination of two work processes, cutting flat bar and the spacing of longitudinal on a panel, Figures 1-2 and 1-3 respectively. The mean and standard deviation of variation in fitting flat bars between longitudinal, Figure 1-7, can be predicted from the data of the individual work processes preceding. In addition to predicting the normal distribution of variation of the final process, the earlier work process which contributed the most to the final or merged variation is identified. In this way, knowledge of current work performance is applied by effective shipbuilders to predict productivity for ship designs never encountered before and, when necessary, to implement countermeasures *before work starts*.

If there is need to reduce rework, accuracy goals are expressed in terms of the normal distribution required for the final process. Then, by working backwards, necessary goals are similarly set for each of the work processes which would insure desired accuracy for the final process. Since normal performance at each work station is known, alternative kidding strategies may be evaluated to determine if reduction in rework can be obtained. If rework reductions by altering design details or assembly sequences are not possible, steps to reduce the normal variations for critical work processes can be initiated. These may include improved tooling, better lighting, retraining workers, or other such approaches. This product of A/C is called process or method analysis. Process analysis involves a detailed review of a particular work process. The goal is to reduce variability, i.e., shifting the mean variation and/or narrowing the standard deviation of the variations of the process. A similar approach can be applied to investigate special causes that are possible for a process being out of statistical control.

Independent normal distributions, such as those representing performance of each work process, can be added to determine the expected normal performance at succeeding stages of construction. Additions of normal distributions apply both to work

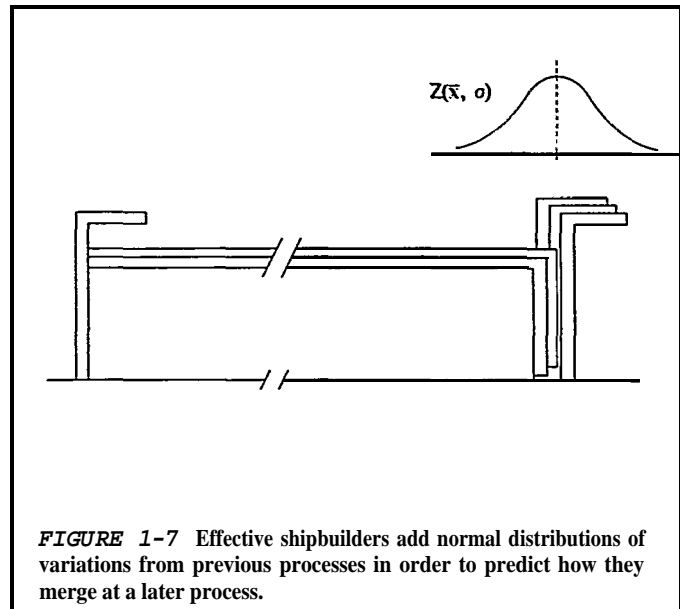

FIGURE 1-7 Effective shipbuilders add normal distributions of variations from previous processes in order to predict how they merge at a later process.

processes necessary to insure needed accuracies of interim products, and to interim products themselves to insure required accuracy of a final product, such as a ship's hull. For the latter, the merged variation, Z , is expressed as:

$$Z = \Sigma P, + \Sigma S, + \Sigma A, + \Sigma E,$$

where:

- $\Sigma P,$ = merged variations from all parts fabrication processes
- $\Sigma S,$ = merged variations from all subassembly processes
- $\Sigma A,$ = merged variations from all block assembly processes
- $\Sigma E,$ = merged variations from all erection processes

This equation is referred to as the variation merging equation for the completed hull.

The variation merging equation is based on the *theorem of addition of variance*. Variance is simply the square of the standard deviation. For independent distributions, such as those representing the normal performance of work processes, the theorem of addition of variance states:

$$s_f^2 = s_1^2 + s_2^2 + s_3^2 + \dots = \Sigma s_i^2$$

where s_i are the standard deviations of earlier processes and s_f is the standard deviation of a final process.

1.2.3 Acceptance Sampling

In the same manner that effective shipbuilders apply accuracy standards to interim products manufactured in-house, they also apply similar standards to materials and interim products in their vendors' and subcontractors' plants. Acceptance sampling procedures are similar in theory to process monitoring using control charts. Suppliers' control charts indicating their normal performances, permit inclusion of their data in shipyards' pertinent variation merging equations even before purchase orders are awarded. In other words, prudent shipbuilders require statistical evidence of quality before issuing purchase orders for materials. When necessary, wise shipbuilders assist their suppliers to implement and maintain A/C systems.

The use of special rolling facilities in some European shipyards is a perfect example of the need to integrate a shipyard's A/C system with a material supplier's A/C system. Japanese shipbuilders include steel mills' statistical evidence of plate flatness in their variation merging equations. As a consequence, they have reached a state where developments in mills and shipyards have eliminated need for shipbuilders to have special rolling facilities. Shipbuilders who impose requirements for statistical evidence for the first time, will learn that some of their suppliers, steel mills in particular, already rely on statistical control methods.

The choice of the level of acceptance sampling for incoming components is an *economic one*. The economic break-even point for no inspection or 100% inspection is based on the average percentage defectives, \bar{p} , the cost of inspecting one part, k_1 , and the cost to dismantle, repair, reassemble and test an assembly that fails because a defective component was used, k_2 . If;

$$\bar{p} < k_1/k_2$$

no inspection should be performed, and if:

$$\bar{p} > k_1/k_2$$

100% inspection should be performed. This results in a minimum cost approach to component acceptance sampling.⁹

Since this analytical approach is either not understood by politicians or inconsistent with their political objectives, government policies focus on identifying low bidders at the expense of obtaining assurances for quality before purchase commitments are made. Among the consequences are substandard products and attendant cost increases. Great assurances and lower total costs are obtained when a shipyard deals with fewer suppliers, fostered to be proficient in MC matters and just sufficient in number, e.g., three per material item, to insure competition. Officials who make material procurement regulations and shipbuilders themselves have to learn that shipbuilders must deal with fewer suppliers for *productivity reasons*. The alternative is continued disruption of shipbuilding efforts, higher costs, claims, investigations and sensational headlines.¹⁰

⁹See "Quality, Productivity and Competitive Position," W. Edwards Deming, M.I.T. Press, Cambridge, MA, 1982 or "Simple Rule to Reduce Total Cost of Inspection and Correction of Product in State of Chaos," Joyce N. Orsini, University Microfilms International, Ann Arbor, MI, 1982.

¹⁰"Procurement Peril: Pentagon Goes After Concerns That Deliver Substandard Products," The Wall Street Journal, 8 July 1985.

2.0 APPROACH

2.1 Overview

A process lane involves sequentially arranged work processes; it is a preplanned entity. Efficiency is dependent upon uniform work flow and coordination with other production lines. Optimum accuracy is crucial in order to avoid disruptive rework. Even nominal rework can break down the economic advantages of process lanes. Thus, when thinking about how a ship is to be assembled, production engineers must address accuracy capabilities. A shipbuilder who has to compete, must support A/C engineers with good systems for collecting and evaluating accuracy data.

In the absence of such measures the following typical questions are disregarded:

- What dimensions are vitally important to achieve required accuracy?
- How is the required degree of accuracy going to be achieved?
- In what work processes should vital dimensions be controlled?
- What are the tolerances that should be imposed at each work process?

Without tolerances specified for each process there is no way to control the accumulation of variations at a final process.

Tolerances in shipbuilding can be classified in two groups:

- *end-product tolerances* - some are fixed as by classification societies, and others which are invoked by owners can be negotiated, and
- *interim-product tolerances* - these are applied by a shipyard to insure compliance with end-product tolerances and simultaneously to *maximize productivity* (tolerances for productivity reasons are often more demanding than those imposed by classification societies and owners).

Without knowledge of how work processes normally perform, tolerances are arbitrary and inhibit constant improvements in productivity.

As a ship owner's guide to what can be achieved at reasonable costs for hull structure, Japanese shipbuilders, classification societies and universities collectively produced tables which describe how their industry normally performs. The tables:

- apply to many details, parts and subassemblies,
- are based upon actual data collected from participating shipyards,
- provide standard ranges of actual dimensions achieved by *normal* shipyard practice (two standard deviations),
- provide tolerance limits which are criteria for rework (three standard deviations), and
- are periodically revised to incorporate the impact of continuing improvements.

Ship owners have to pay more if they specify closer tolerances than those normally achieved as described in the foregoing.¹

¹"Japanese Shipbuilding Quality Standard (Hull Part) - 1982" by the Research Committee on Steel Shipbuilding, The Society of Naval Architects of Japan. When this document is referenced in contracts, the contract price is based upon industry-wide normal performance of work and there is clear agreement between owners and shipbuilders concerning what constitutes rework. When owners require extraordinary accuracy, such as for naval ships, the booklet becomes the basis for negotiating additional costs. Early in 1985, ABS Worldwide Technical Services, Inc., and major U.S. shipbuilders, as part of the National Shipbuilding Research Program, started preparation of a similar publication applicable to the U.S. shipbuilding industry.

Standard ranges are indicated with the same plus and minus notations used to fix tolerances. However, they are not tolerances. Instead, they are a measure of the actual accuracy capability of the processes used by a shipyard based on previously collected data. A standard range reflects the accuracy range currently obtainable with 95% probability, for a particular work process. Tolerance limits required for interim products and end products, whether for productivity or quality/functional considerations, should encompass the associated standard range, as shown in Figure 2-1. Where they do not, rework can be regularly expected.

The use of ranges and limits as described in the foregoing is proven and acceptable to classification societies. Such use and continuing analyses of data enable Japanese managers to know where they are regarding accuracy being achieved and where they stand regarding acceptance. They know what they have to do next to improve their shipbuilding methods. Their abilities to regulate accuracy are a powerful means for managing shipbuilding operations.

The disciplines for producing statistical evidence are particularly credited by Japanese shipbuilders for tremendous improvements in productivity. In 1967 they reported in English that statistical control of manufacturing "epoch makingly" improved the quality of hull construction, laid the foundation of modern ship-construction methods and made it possible to extensively develop automated and specialized welding.²

Statistical analysis of accuracy variations of a shipyard's current work processes can be used to predict how accurate hull structure will be in a ship never built before. This has great significance for owners, particularly the Navy. Abilities to withstand high-impact shock are directly related to accuracies achieved without forced fitting during construction processes. Maximum submergence depth of a submarine is related to the degree of hull circularity achieved and absence of locked in stresses. Thus, the Navy's possession of statistical evidence of accuracy from shipyards before award of contracts, would serve military requirements?

As quality and productivity are directly related and since A/C provides an analytical basis for less direct inspection, there are prospects for savings by both shipbuilders and owners. Owners, shipbuilders, and suppliers need to further exploit statistical control of manufacturing.

An important aspect of A/C is the difficulty commonly encountered in joining blocks during hull erection. Erection joint gaps that are not within tolerance limits must be reworked by gas cutting and/or buildup by back-strip welding as shown in Figure 2-2. Effective shipbuilders have proven that applying A/C to all earlier work processes is more productive than having to deal with excessive merged variation in relatively inaccessible and hazardous locations at a building berth.

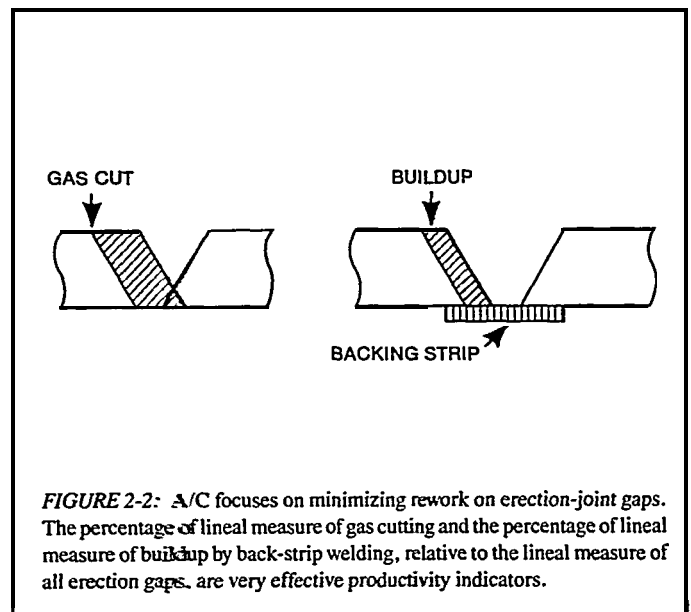
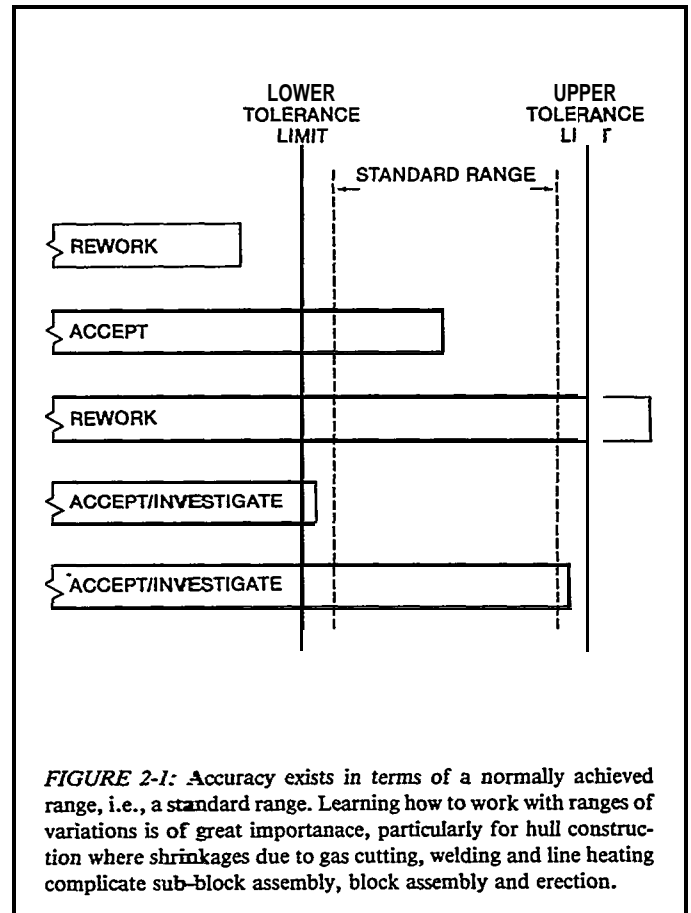

²"Technical Progress in Shipbuilding and Marine Engineering," The Society of Naval Architects of Japan, 1967.

³"Toward More Productive Naval Shipbuilding," Committee on U.S. Shipbuilding Technology, National Research Council, National Academy Press, Washington, D.C., 1984, p. 130.

Margins to be trimmed at an erection site are commitments to rework. Their use should be minimized. Statistical methods can be used to anticipate normal dimensional variations and to provide compensation, such as specific allowances for excess to compensate for shrinkages caused by gas cutting, welding and line heating. Most of the edges of parts, sub-blocks, and blocks are finish cut accordingly.

A/C starts with statistical analysis of variations generated at each of the prerequisite work processes for hull erection, i.e., work processes during block assembly, sub-block assembly, part fabrication, lofting and design. First time examination of actual measurements recorded for any work process, usually discloses that the variations:

- are greater than any manager imagined, and
- when plotted by frequency of occurrence vs. magnitude, usually follow the normal (Gaussian) distribution if the work process is repetitively applied without change.

When the distribution of variations for a specific work process is normal, the process is said to be under control.

Obtaining a mean and standard deviation for each process under control makes it possible to:

- express the standard deviation of variations at erection as a combination of the deviations of variations from preceding work processes,
- establish an order of priority for “tightening up” preceding work in order to reduce the accumulation of variations for the final work process,
- establish accuracy standards,
- revise written work and A/C procedures,
- direct changes in design details which will enhance productivity,
- predict changes in work sequences that will enhance productivity, and
- identify specific work processes that should be improved.

Generally, structural work processes which require statistical analyses are:

- *Part Fabrication*

- *marking*
 - marking method by template
 - ink marking
 - right angle tool and method
 - thread length and diameter

- *cutting*
 - tip nozzle and oxygen pressure
 - matching of rails and torch
 - machine error
 - height of torch above plate

- *bending*
 - shift of neutral axis
 - deformation of template
 - matching of templates
 - matching roundness of ends

- *Sub-block assembly*

- *fitting*
 - gap at fitting
 - matching method by jig
- *welding*
 - welding condition
 - sequence of welding
 - fitting gap
 - level of platen
- *fairing*
 - method of fairing (e.g., line heating)

- *Block Assembly*

- *plate joining and fitting*
 - degree of fitting gap
 - matching method by jig
 - level of platen
- *automatic welding*
 - running direction
 - condition of welding
 - leveling
 - method of securing angle
- *marking*
 - ink marking method
 - tool and method for right angle
 - thread length and diameter
- *cutting*
 - tip nozzle and oxygen pressure
 - matching of rails and torch
 - machine error
 - distance of torch from plate
- *assembly and fitting*
 - fitting gap
 - matching method of base line
 - leveling
- *welding*
 - condition of welding
 - sequence of welding
 - binding method
 - positioning apparatus

- fitting of reverse-side members and welding
 - positioning method
 - angle setting method
 - sequence of welding and condition

•• Erection

- positioning
 - cribbing arrangement and leveling
 - method of leveling
 - method of deciding inclination
 - slope of building berth
 - bending and twisting of block
 - rectangularity of hull body
- welding
 - condition of welding
 - sequence of welding
 - joining gap and shape of edge preparation

Outfit work processes can be controlled using similar statistical techniques.

As shown in Figure 2-3, any A/C activity can be classified into one of three basic management functions that are inherent in any industrial enterprise:

- planning,
- executing (field work), and
- evaluating (analyses and feedback).

Thus A/C responsibilities can readily and effectively be incorporated in any existing organization provided:

- one operations manager has responsibilities for *all*, not just A/C planning, executing and evaluating operations,
- planning includes design and material definition, and
- within organizations such as a hull-structural design section, production-engineering group or sub-block assembly section, people with pertinent qualifications are assigned specific and substantial A/C responsibilities.

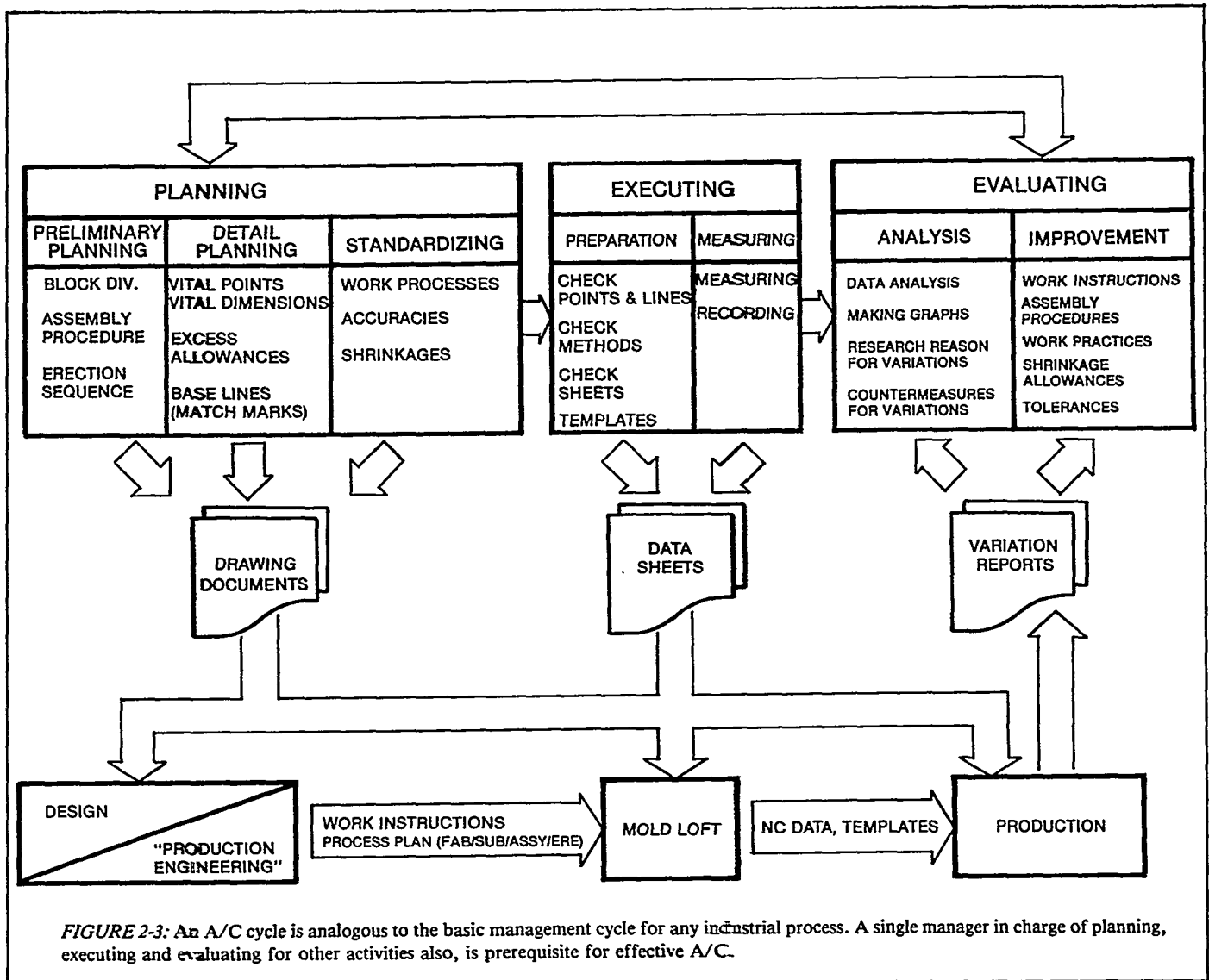

FIGURE 2-3: An A/C cycle is analogous to the basic management cycle for any industrial process. A single manager in charge of planning, executing and evaluating for other activities also, is prerequisite for effective A/C.

Effective A/C is critically dependent on unified operations, organized information and qualified incumbents. A special A/C organization is not a prerequisite. But, people throughout a shipyard who are assigned A/C responsibilities must at least function as a defacto A/C group. The person who maintains the principal A/C overview for an operations manager is a key individual.

2.2 Start-up

As previously described, prerequisites for successful implementation of A/C include the adoption of PWBS, the use of line heating and the collection of an A/C data base. Establishing an A/C system in a shipyard is facilitated by:

- top management commitment to PWBS and A/C,
- choice of a construction project for start-up,
- informational meetings involving design engineers, production engineers, welding engineers, department and shop managers including the loft manager, and worker supervision,
- written fitting and welding sequences,
- estimated tolerance limits,
- estimated excess to compensate for shrinkage,
- check sheets,
- collection of data, and
- analyses of data, design details and work sequences by a production engineer who understands A/C.

Successful implementation requires understanding of A/C short- and long-term goals, and understanding that while a special A/C group may be required for start-up, A/C should be implemented as a shipyard-wide system collateral to other responsibilities. Thus, when routinely functioning, an A/C system is operated by design engineers, production engineers, material managers and, especially, by production supervisors who are simply applying statistical analysis techniques for furthering their regular work.

Initially, participants can be expected to focus only on accuracy per se so as to immediately improve process flows and minimize rework during erection. They will, just by paying more attention to accuracy, achieve significant productivity increases. Thereafter, they will achieve no more productivity increases in the next twenty years than they did in the twenty years before. With a few "specialists" monitoring accuracy at modest cost, the temptation to ignore or delay the long-term objective, which is to create a constantly self-developing manufacturing system, is very strong. All is dependent upon management recognizing that an A/C data base is a capital investment, i.e., literally, per a dictionary definition, *a possession calculated to bring in income.*

Such top management funding commitment is not enough. While a shipyard president will understand the long-range objective and while a shipfitter would only require a half hour of instruction to understand what an A/C engineer requires, the functionaries in between are not likely to understand the need for their cooperation. Thus, as a matter of prime importance, top managers have to make a special effort to educate all middle managers, particularly shop managers, that A/C is a subset of a very basic and effective management control system. As a means of emphasis, top managers should adjust their cost reporting systems to specifically address rework, e.g., gas cutting and buildup by back-strip welding needed to facilitate automatic or semi-automatic erection welding.

Getting a system started requires careful consideration of the idiosyncracies of a particular shipyard, including its organization, people, facilities, work load, etc. Of utmost importance is a commitment by top management coupled with understanding that it may take five years for a constantly self-developing manufacturing system to be realized. A moderately stable workload for a number of years is certainly an important part of such favorable conditions.

Given the commitment and work load, an initial step would be the choice of an upcoming construction project for preliminary implementation. This will establish a sense of urgency, at first by production and design engineers and then by shop managers, first-line supervisors and workers. The choice should be made early enough to permit all preparations to be completed prior to the start of production work. Design and production engineers have to assume the largest preparation burden. Allowing them ample time and manpower is essential.

If A/C and a PWBS are introduced at the same time, the engineering workload will rise dramatically. PWBS requires unprecedented amounts of integrated production engineering and design efforts to be completed before production work starts. In addition to grouping information in a different way to suit product-oriented methods, much written information is required for implementation of A/C. The subjects which must be addressed include prescribed work methods, fitting and welding sequences, tentative tolerance limits, tentative rules for excess allowances and check-sheet usage. Consequently, the lead time and resources for simultaneously implementing PWBS and A/C should not be underestimated.

As production engineering and basic design activities begin, a series of meetings should be held involving production engineers, designers and shop managers. Representatives of the loft and welding engineering should also participate. Discussion should address integrated hull construction, outfitting and painting in conformance with a PWBS and both the short-term and long-term purposes of A/C. Production people in particular, should be indoctrinated in devising check points and check dimensions that designers can include in drawings to facilitate assembly work. Also, production supervisors must be directed to consistently use the best known methods per work stage of a process flow. They have to be taught the concept of *normalcy* and the imperative need to achieve Gaussian distributions of variation. They must be made to understand that only then can a work process be said to be in control.

Everyone involved in implementing A/C understand that only when work is in control, can statistical distributions of variations be used to predict with confidence the quality and productivity for a contemplated end product having design details never encountered before. Sophisticated customers require such statistical evidence of quality and productivity before contract award. As such predictions direct attention to specific work methods which when improved do the most for improving the productivity of an overall manufacturing system, A/C is the singular element of competition among the most effective shipbuilders. Failure of a traditional shop manager to cooperate will have serious consequences because of the increasing complexity of shipyard end products and because of shipbuilders' urgent needs to become more flexible in market places. In the most effective shipyards, understanding statistical analysis and contributing to A/C systems are prerequisites for shop management.

During such indoctrination, emphasis should be made of the tentative nature of tolerance limits per stage because when work becomes in control, consistent with statistical theory the limits are regarded as three standard deviations. That is, when work is performing normally, probably 99.7% of the items being worked will be within tolerance limits and probably only 0.3% will require rework. When performance of work changes so as to affect a normal distribution, the tolerance limits change accordingly.

If tolerance limits are not acceptable for customer specified requirements or for facilitating work downstream, such as for welding of erection butts and seams, management responsibility is automatically acknowledged and resolution may involve design modifications, changes in work sequences, additional training for workers and/or inventing a new work process until tolerance limits are acceptable. In other words, by definition and with 99.7% probability, no requirement is imposed that workers cannot fulfill through their *normal* performance of work.

Both the iterative nature of and time span required to achieve a working A/C system must be made clear to everyone involved. Implementation throughout a shipyard is difficult but necessary. A choice of one or two specific areas will ease start-up. Application to parts and assemblies for simple structures, such as, for double bottoms and wing tanks, is an ideal early choice. Later more complicated structures and outfitting work, including that assigned to subcontractors, should be addressed based on results of initial attempts. Responsibilities for specific tasks within an overall framework must be assigned. Subgroups, made up of people from production engineering, design and production shops should evolve naturally if a product organization is in place. These groups will develop check sheets and initial sequences, tolerance limits and excess allowances. As such information is developed, individuals having primary responsibilities, such as loftsmen, gain insight and are able to continue with fewer and shorter instructional meetings.

Initially estimated tolerance limits and excess allowances are included on work instructions. With more data and analysis, the limits and allowances are refined and revised. As the data base grows it will be more and more relied upon as a management tool and its status as capital become indisputable.

Written procedures for work processes are essential prior to any data measuring. Following the same procedure per work stage is essential in order to achieve a normal distribution of variations. Particularly in product organizations where specialization is by problem categories, developing work procedures causes an interaction between production engineers, designers and shop people during which each learns more of the others' requirements. As emphasis is placed on constant improvement in methods, these work procedures are "standards" of the moment which are revised as soon as better methods are manifest. Thus, the vital interaction of production engineers, designers and shop people prodded by continuing directions emanating from statistical analysis, continues forever.

Data collection should be a production responsibility equivalent to marking, cutting, fitting, welding and distortion removal. A typical approach might involve unrecorded measurements of all products by each worker followed by recorded measurements based on random sampling by a first-line supervisor and again by a second-line supervisor. What is most amenable for each shipyard should be adopted, as long as measuring is a shop responsibility. As for any other shop work, allowances should be made in schedules for measurement work.

Measurements serve multiple functions. They facilitate achieving the short-term goal of minimum rework during hull erection. Thus, during start-up, one set of measurements should follow an interim product through its work stages. Measurements and tolerance limits preclude arbitrary accumulation of variations since unacceptable work is not passed on to later work stages. The data also provide statistical performance indicators for incorporation in the A/C management scheme, i.e., an A/C analysis group determines the mean and standard deviation per work stage. An extremely important part of an A/C system is to publish the analyzed data in a form that everyone, workers included, will readily understand. This function, essentially feedback, holds the key to achieving positive returns from investment in an A/C system.

Traditional production people can no longer react to problems without regard for the informational requirements of an A/C system. The best solution to a problem encountered might be in design, material procurement or in an earlier work stage. Thus changes and problems must be documented and resolved with production engineers and designers as dictated by statistical analysis. Unless benefits are overwhelmingly manifest, changes in work procedures per work stage should only be accomplished when the impact on the entire manufacturing system is determined by statistical analysis.⁴

⁴ Concerning descriptions in writing, a Sicilian proverb says, "White soil, black seed. Beware of the man who sows it. He never forgets." And so it is with A/C because *real* performance data are recorded and continuously analyzed in behalf of an entire manufacturing system. It constantly targets problems, it monitors rates of improvement and it never forgets. Traditional shop managers are apt to be apprehensive. Ineffective shop managers have reason to be apprehensive.

3.0 PLANNING

Planning is essential for the proper functioning of an A/C system. Design and production engineering are aspects of planning. Figure 3-1 outlines an A/C planning process. Since variations will occur at each level of production as shown in Figure 3-2, one aspect of A/C planning is to determine at what stages of construction action must be taken to minimize rework during hull erection; see Figure 3-3.

Basically, what is shown is the role of A/C planning to:

- pinpoint what vital points and dimensions are critical to the dimensional and geometrical accuracy of blocks,
- designate critical check points and reference lines in blocks and in sub-blocks and parts from which blocks are assembled,
- specify locations for and amounts of excess allowances,
- decide where and how much margin is to be used and the specific stages at which margins should be cut neat,
- determine work processes during which check measurements will be made,
- fix the numbers of interim products that should be measured based upon random sampling, and
- incorporate tolerance limits, excess allowances and margins in work instructions.

A/C planning is best performed together with other planning elements provided it receives at least the same emphasis. For effectiveness, specific A/C responsibilities should be clearly defined and specifically assigned to individuals. As previously shown in Figure 2-3, A/C planning can be divided as other major planning aspects into:

- preliminary planning,
- detail planning (preparation of work instructions), and
- standardization.

3.1 Preliminary Planning

Preliminary planning addresses such matters as block divisions, hull straking, and assembly procedures. Necessarily, preliminary planners must consider among other things:

- how to create blocks that facilitate shipwright work,
- how to strake the hull shell in order to design hull plates that can be accurately formed by available bending facilities and techniques, and
- how to shape blocks that are spacious and open to facilitate zone outfitting.

In order to carry out such studies systematically, drawings such as general arrangement, midship section and lines and proposed schemes for block divisions and shell straking, are provided by designers to the planners who are assigned at the hull-construction department level and to the parts-fabrication shop, sub-block assembly section, block assembly section and erection section. As a routine matter the same information is equally available to the specific engineers among the planners who have been assigned A/C responsibilities. They use variation merging equations with statistically obtained assessments of normal accuracy performances and propose optimum design details, assembly and erection sequences, tolerances, etc., accordingly. The final scheme is fed back to designers who then develop key plans, such as a shell expansion, a block plan and ultimately work instructions all of which contain A/C derived requirements.

3.2 Detail Planning

A/C considerations in detail planning are really process analyses from an A/C viewpoint. Through such analyses problems which can be solved by regulating certain dimensions, are revealed in advance. In other words, in order to obtain required accuracy for a final process it is necessary to first identify the specific preceding processes that are mostly contributing to a final or merged variation. Thus A/C analyses identify on a quantitative basis, both the work processes and design details which should be improved.

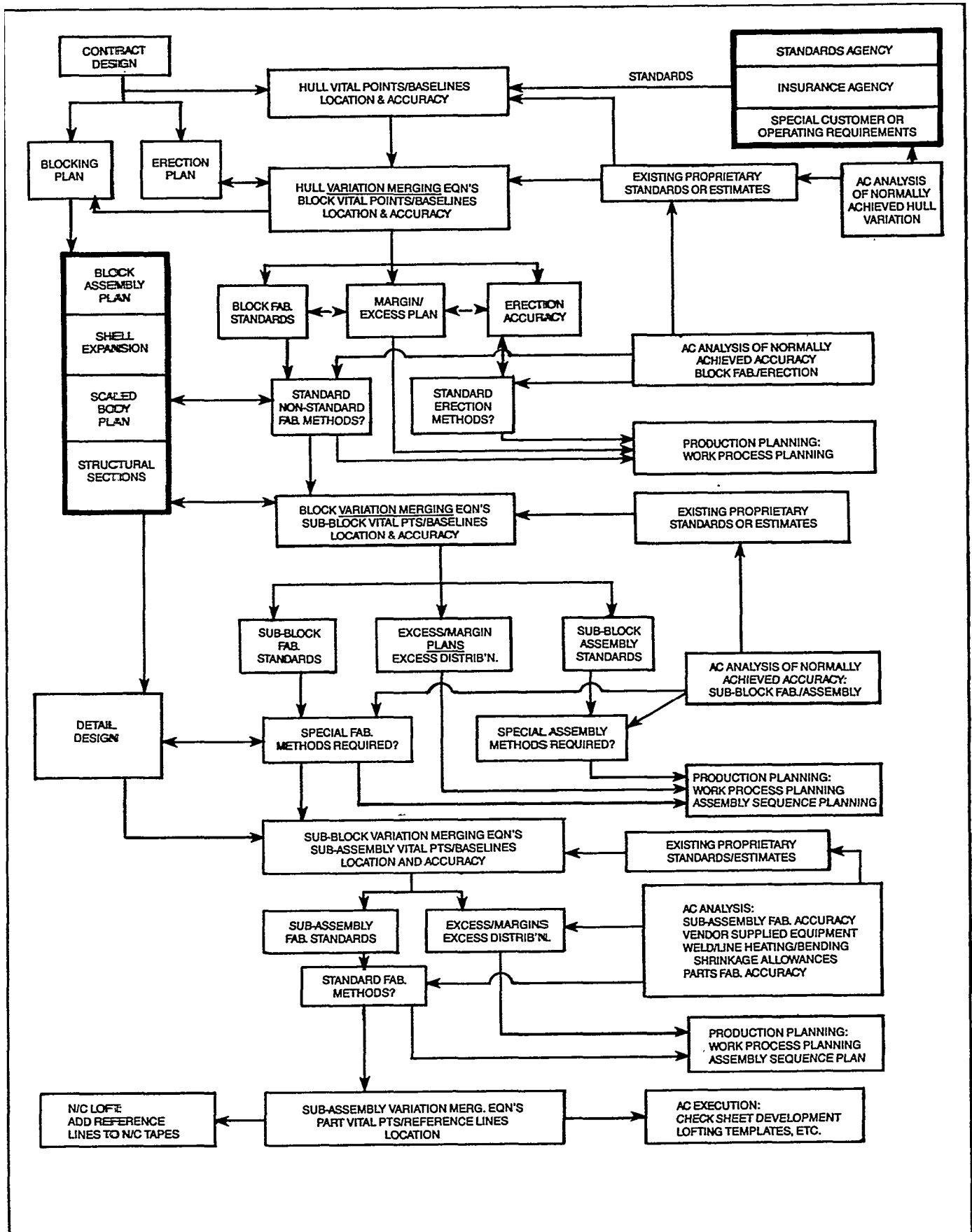

FIGURE 3-1: An A/C Planning Process.

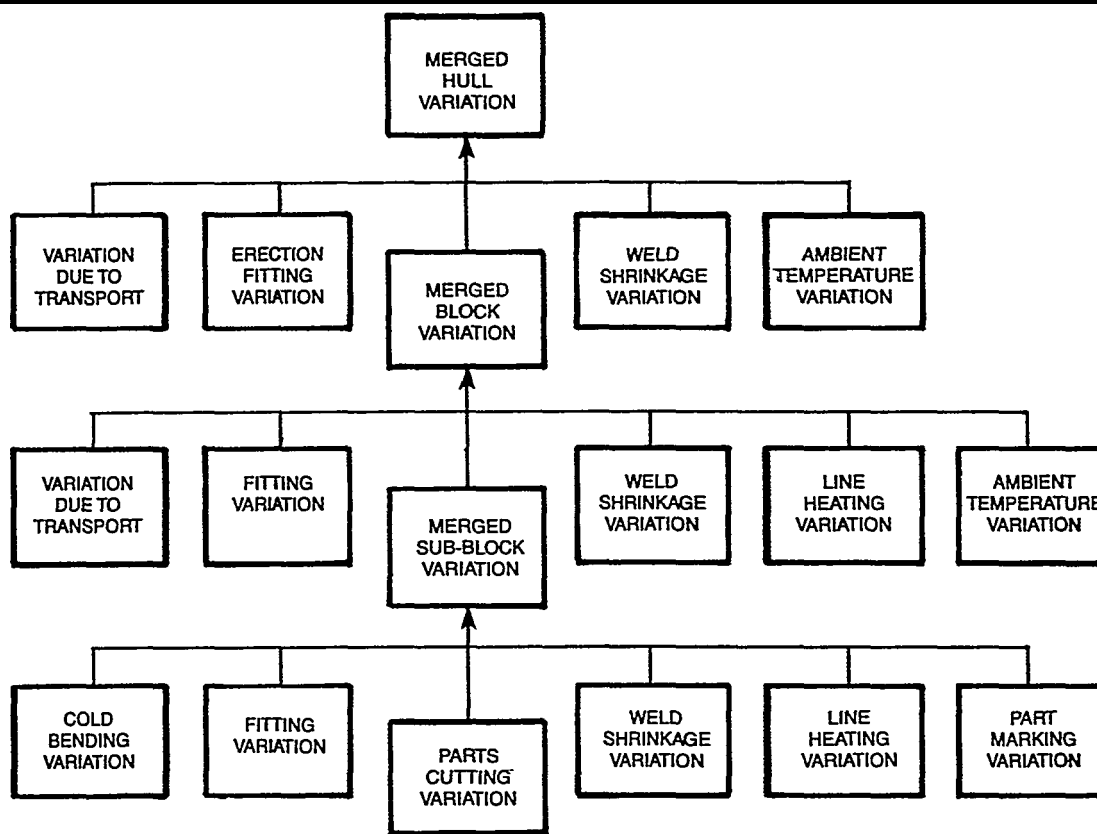

FIGURE 3-2: Variation per manufacturing level.

Of course, such determinations are not made solely from an A/C viewpoint. A/C techniques are analytical management tools that contribute to process analyses. They are means for a shipyard as an entity to capture and scientifically derive benefits from its accuracy experiences. The alternative is to have such experiences just vested in individuals who can demonstrate some pertinent, *parochial* expertise, but who can only guess about how their accuracy achievements impact on other work processes. A/C methods in detail planning are significant because they inherently address the entire hull construction process for the purpose of reducing erection work.

Planning proceeds by first assessing the accuracy characteristics for an end-product as specified by a regulatory society and ship-owner. Thinking of reverse process flow, A/C planners identify vital points and dimensions that must be maintained during erection, block assembly and so on as further described in Appendix A. In consideration of such vital aspects A/C planners insure that via work instructions and other means, loftsmen and people having A/C field responsibilities, are provided with necessary information such as check points and reference lines that must be included in numerical control (N/C) data, templates and field check-sheets.

Engineers who perform A/C planning for construction of a ship, recognize that most accuracy variations in work processes are normal and their impact on an end product can be predicted through statistical methods. The statistical terminology, notations and formulas included in the following passages, are further explained in Appendix B.

Simultaneously with the designation of required work procedures for a specific interim product, tolerances and amounts of excess are determined by taking into account the merging of variation. Variations generated by each work process follow a normal distribution, $N(\bar{x}, s)$, and accumulate as another normal distribution, $Z(\bar{x}_z, s_z)$, at the last stage. In order to reduce the merged variation, Z , it is necessary to reduce the standard deviation, s , and control the mean value, \bar{x} , of each process considering their effects on current production methods.

An example of how A/C planners are already using them to predict merged variation in a bottom butt, to be joined during hull erection, is shown in Figure 3-4. Additional examples are contained in Appendix C. Included, are examples of how A/C process-analysis leads to design improvement and how a change in sequence can reduce the number of work processes required.

A/C planners also apply their abilities to predict merged variation within every manufacturing level. For example, for block assembly they use the normal distributions for each work process, i.e., panel assembly, panel marking, panel finish-cutting and internal-member welding, to predict the normal distribution for blocks currently being planned. The same technique is employed for sub-block assembly and for part fabrication.

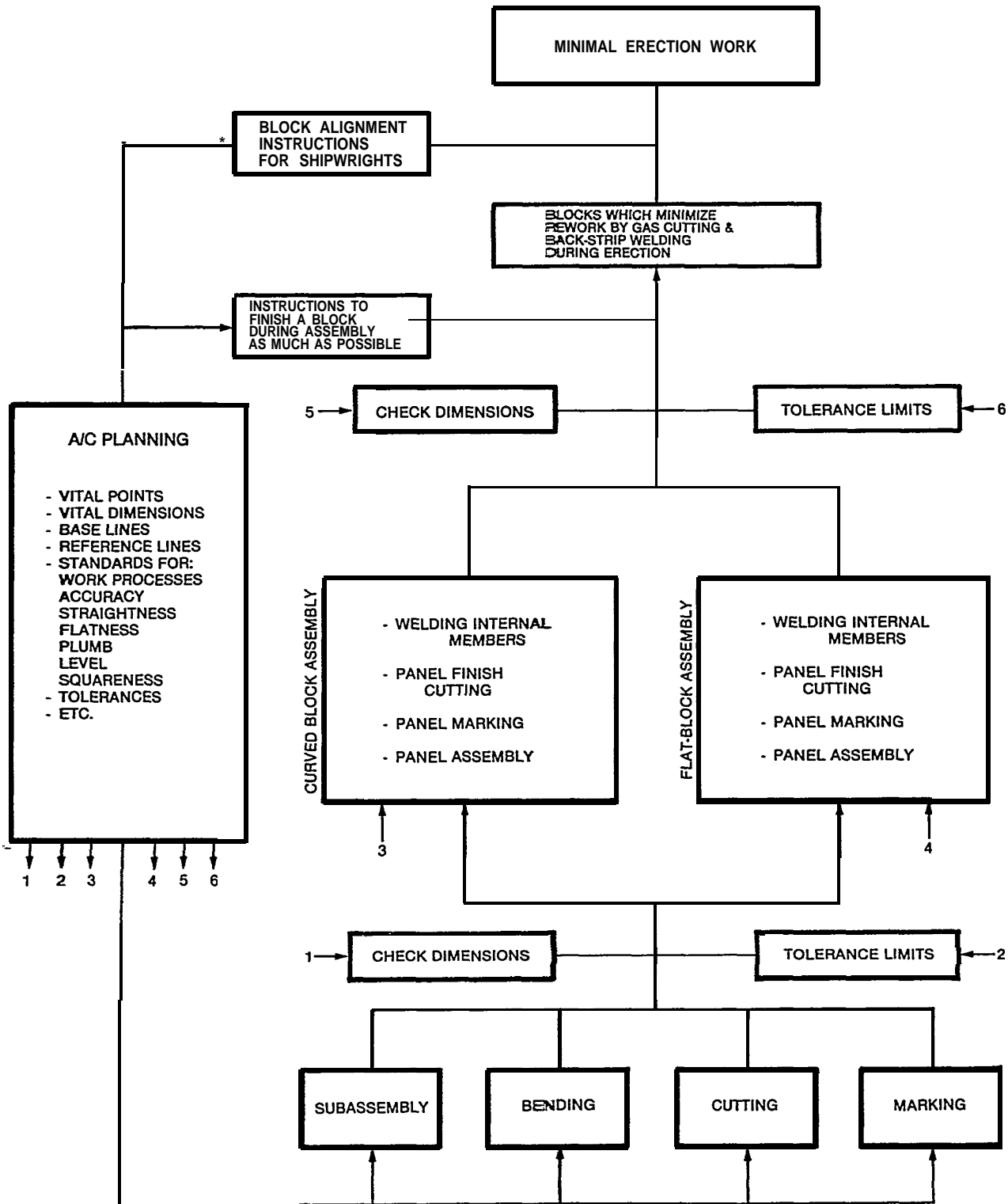

FIGURE 3-3: In addition to defining how to count (statistically), A/C defines what to count and when (at what stage) to count.

As a consequence of their improved foresight. A/C planners advise designers of specific A/C matters that are to be included in work instructions. Although written descriptions are frequently necessary, symbols such as shown in Figure 3-5 are useful.

3.3 Standardization

3.3.1 Work Standards

Any work process performs with varying degrees of accuracy. When it is *controlled* so that it is always applied the same way, variations will be normally distributed and can be analyzed based on the laws of statistics. Thus, a crucial part of A/C is to insure that accuracy variations remain random and are not the result of arbitrarily introduced bias. Standardization of work processes and monitoring to insure compliance, are fundamental concerns of A/C people. A/C authorization of a proposed change in any work process, insures scientific analysis of its impact on the entire shipbuilding process.

This rigid control does not mean that changes are not made. Instead, adjustments to work processes are more frequent due to the continuous process analyses and feedback which are inherent features of A/C.

Related standards should be written and adhered to for such matters as:

- planned steel flow,
- worker organization,
- worker training, and
- supervision.

All, if changed without regard for A/C analyses and approvals introduce biases which invalidate any approach to A/C.

In shipyards which are not effective almost all of the problems found in production are caused by the absence of:

- *Standards for Excess*

At the startup of A/C activity the following questions are appropriate:

- Why are margins needed?
- Where are margins required?
- How much margin is necessary?
- During what work process will margins be finish-cut?

Usually, a margin scheme for main strakes, such as shell plates, is created by production planners. Margins shown are for ordering materials and/or fabricating parts. However, the amounts of margin are not prescribed by written standards that are backed up by records of measurement data. In this respect margins differ from excess allowances. Margins are used as a buffer to com-

pensate for accuracy variations in all hull construction processes including design. Therefore, the true causes of accuracy variations and ways to improve fabrication methods are difficult to detect. Where A/C is not applied, the large amounts of margin used are based on "rough check" data which characterizes feedback from production. This vicious cycle disallows opportunities for improvements.

A/C scrutiny reduces margins until most of them become just the excess allowances needed to compensate for shrinkages. Excess is characterized by finish cutting based on a high probability that no rework will be required. When this transition is achieved, in order to further eliminate rework, A/C continues to impose the same questions:

- Why is excess needed?
- Where is excess needed?
- How much excess is necessary?
- If needed, during what stage should rework take place?

This incessant questioning is motivation for continuous improvements in work methods.

- *Standards for Shrinkage Allowance*

The amount of shrinkage caused by welding will be different depending upon materials, methods and sequences. Thus, shrinkage allowances are meaningless unless they are based upon recorded data for each set of circumstances.

- *Standards for Baselines and Match Marks*

Even where the necessity and importance of baselines and match marks are recognized, their locations and lengths do not sufficiently reflect the production requirements that should be described in a standard.

- *Standards for Checking Procedures*

A written checking procedure assures specified accuracy at each work process. Because no written checking procedures exist, few measurements are recorded for analysis.

- *Standards for Fabrication and Assembly Schemes*

The sequences for sub-block assembly and block assembly are usually indicated by a numbering system, useful for computer processing, which is hierarchical in order to match ascending manufacturing levels. This system is good enough to indicate a simple sequence such as part fabrication, sub-block assembly, block assembly and erection, but it does not address vital points and dimensions needed to achieve specified accuracy during each work process.

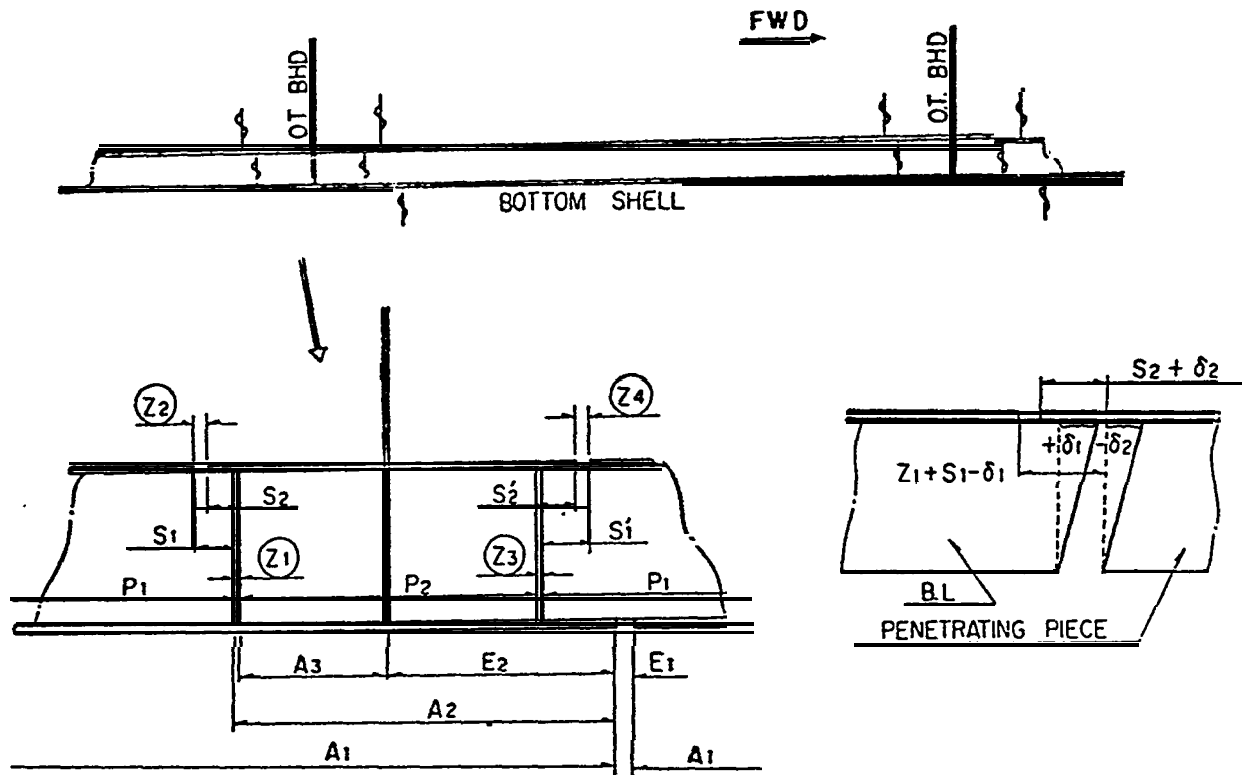

Assembly Procedure:

1. Fit the flange on the web shifted by S_1 (fwd end of longitudinal).
2. Fit the flange on the web shifted by S_2 (aft end of penetrating piece).
3. After the plates are welded together to create the bottom panel, incorporate a 3mm excess allowance and finish cut the panel's forward edge.
4. Fit the longitudinals to the bottom panel shifted by A_2 where $A_2 =$ the designed dimension + 2mm.
5. Fit the penetrating piece to the transverse bulkhead at the distance A_3 .

Variation Merging Equations for the Joint Gaps During Hull Erection:

$$Z_1 = A_2 - (A_3 + E_2)$$

$$Z_2 = Z_1 + [(S_1 - \delta_1) - (S_2 + \delta_2)]$$

$$Z_3 = [E_2 - (P_2 - A_3)] - [(P_1 + A_2) - (A_1 + E_1)]$$

$$Z_4 = Z_3 + [(S_1' - \delta_1') - (S_2' + \delta_2')]$$

- A negative value for Z predicts overlaps, i.e., negative gap.
- The value for every A, E, etc. is dependent upon a similar lower-tier equation which accumulates variations for marking, cutting, etc. as measured from a reference line.

FIGURE 3-4a: Variation merging equations are used to predict gap sizes which will occur during hull erection and probabilities for rework.

ESTIMATED MERGED VARIATION (Z)

Dimension	Sample size n	Mean value \bar{x}	Variance s^2	Remarks
P ₁	126	+0.4	0.91	Length of bottom longitudinal after web is welded to flange.
P ₂	50	+0.5	0.79	Length of penetrating piece after web is welded to flange.
δ_1, δ_2	156	0	0.51	Perpendicularity of bottom longitudinal and penetrating piece ends.
δ'_1, δ'_2				
S ₁	140	+1.1	0.61	Fitting position of bottom longitudinal flange.
S ₁ '	140	+0.5	1.61	Shift between web and flange at the after end of bottom longitudinal.
S ₂	50	-0.4	0.81	Fitting position of flange of penetrating piece.
S ₂ '	50	+0.6	1.82	Shift between web and flange at the forward end of penetrating piece.
A ₁	36	+2.9	1.38	Length of bottom panel after finish cut.
A ₂	83	+1.6	1.64	Fitting position of bottom longitudinal.
A ₃	70	-0.8	2.02	Fitting position of penetrating piece.
E ₁	42	-0.4	2.43	Accuracy of gap between bottom panels measured between reference lines after welding.
E ₂	44	+1.9	4.60	Erected position of Transverse Bulkhead; Distance from butt of bottom panel.
Estimated Gap				
Z ₁	_____	+0.5	8.26	_____ * 7%
Z ₂	_____	+2.0	10.70	_____ * 17%
Z ₃	_____	+1.0	13.79	_____ * 14%
Z ₄	_____	+1.0	18.22	_____ * 17%

* Estimated occurrence of gaps which are 5 or more mm wide; back-strip welding is required. The method for calculating these estimates is described in Appendix E, Figure 8.

ACTUAL MERGED VARIATIONS

Actual Gap	Sample size n	Mean value \bar{x}	Variance s^2	Actual occurrence of back-strip welding
Z ₁	85	+0.8	7.61	4%
Z ₂	82	+2.3	9.71	12%
Z ₃	78	+1.1	10.02	6%
Z ₄	72	+2.2	13.75	13%

FIGURE 3-4b:

• *Standards for A/C Information in Work Instructions*

Usual hull-construction drawings show structural details and sometimes include instructions for edge preparations. Specific excess allowances are generally not included. Little other guidance is provided by designers to indicate fabrication methods and vital points and dimensions needed to achieve a specified degree of accuracy.

Working drawings are the only widely distributed documents provided to workers which can display total instructions for how to construct a ship's hull. When design is recognized as an aspect of planning, working drawings will develop more as work instructions which facilitate employment of less-skilled workers, adherence to work standards, A/C analyses and continuous improvement in production methods.

3.3.2 *Accuracy Standards*

In order to control the accumulation of variations or merged variation at a final stage, accuracy standards are established for preceding work processes. Data obtained during construction of other ships is used to derive accuracy standards for a contemplated ship. However, these are reviewed by analyzing data recorded as production commences and progresses. Adjustments are made if assumed accuracy standards are manifestly unrealistic.

The concept of a *standard range* with a *tolerance limit*, as shown in Figure 2-1, is applied to every work process. The more demanding standard range is used as the accuracy standard for each particular work process in order to insure control of the merged variation at erection. By definition, stan-

ard range is associated with high probability ($\bar{x} \pm 2s$ or 95% for shipyards in Japan).

Of the few remaining variations, those outside the standard range which do not require rework during the next work stage nor spoil end-product accuracy, are acceptable and are regarded as being within a tolerance limit. In other words, a tolerance limit because it applies to *fewer* cases includes some added allowance for acceptance. However, such limits must be achievable with normal production capabilities and must not impair structural integrity of the end product.

This approach recognizes basic realities in any industrial enterprise. While more demanding accuracy standards are applied to normal operations, some allowance is made for the effect on accuracy by on-the-job trainees, newly developed machines, etc. The concept of a standard range with a tolerance limit encourages managers to react to trends away from normally achieved accuracy *before* rework is required.

Typical standard ranges and tolerance limits that are employed for standardization by Japanese shipbuilders are tabulated in Appendix D. These standards, because they have been revised five times in thirteen years, reflect constant "A/C" scanning of work processes which forced industry-wide advances in shipbuilding technology. The constant upgrading is a measure of competition between national shipbuilding industries.

Some shipbuilders further developed the accuracy standards to address more design details and to further "tighten" work processes as a means for competing with each other. Pertinent samples are also included in Appendix D. The extent of this independent, further development of accuracy standards is a measure of competition between shipyards.









Stage	Description	Abbr.	Remarks
Lofting	Dimension Accuracy		Standard = 0.5 Shows Allowable ± 1 m/m
	Ditto		Standard S = 0.7 Shows Allowable ± 1.5 m/m
Marking	Ditto		Standard S = 1.0 Shows Allowable ± 2 m/m
Cutting	Material Angle Accuracy		Standard S = 0.5/1000 Shows Allowable $\pm 1/1000$
	Material Shape Accuracy		Standard S = 0.7 Shows Allowable ± 1.5 m/m
Sub-block Assembly	Fitting Accuracy for Providing FC PL		Standard S = 0.7 Shows Allowable ± 1.5 m/m
	Fitting Angle Accuracy		Standard S = 1/1000 Shows Allowable $\pm 2/1000$
	Edge-Fitting Accuracy		Standard S = 1.0 Shows Allowable ± 2 m/m
	Edge Straightness Accuracy		Standard S = 1.0 Shows Allowable ± 2 m/m
Block Assembly	Dimension Accuracy Fitting Line Accuracy Other Accuracies	NB	Allowable $\pm 1 \sim \pm 2$ to be described in stage plan, accuracy plan and other plans as nota bene
Hull Erection	Shipwright Accuracy Level Accuracy Accuracy between Vital Lines Main structure Fitting Accuracy Inner structure Fitting Accuracy Other Accuracies		

FIGURE 3-5: A/C symbols for work instructions.

4.0 EXECUTING

A/C execution is concerned with: defining who measures, when and how measurements are made, and recording data.

4.1 Self Check

A/C includes a self-check system which workers and their immediate leaders execute. Self checks are crucial. Workers have not completed a job until they have checked their work to assure compliance with written accuracy instructions. Thus, self checks are regarded as work just as much as any other work task. Subsequently, work leaders, one for approximately every eight workers, check the same work and record the pertinent final data accordingly. Very important check points and lines, i.e., control items, are again checked and recorded by the next higher level of supervision. If such data are unreliable or not available there is no point in having WC.

4.2 A/C Group

Where WC is successfully applied, people having responsibilities to execute A/C procedures are assigned in the hull construction department. All are members of a yard-wide A/C group, have 8 to 9 years of varied shipbuilding experiences and were carefully selected on the basis of their aptitude for and commitment to improving productivity. Their responsibilities are

- to check items which are so crucial that they should not be just dependent on the self-check system.
- trouble shooting,
- A/C of subcontracted items,
- further development of the A/C system,
- analysis of information collected by the self-check system, and
- convening a monthly A/C group meeting, chaired by the senior operations manager and attended by the managers and deputies of the major divisions of the operations department, for discussion of productivity matters.

As participation provides an excellent overview of planning, executing and evaluating, A/C group experience is prerequisite for higher managerial responsibilities. And, because increased productivity is dependent on more managers acquiring a complete overview of the entire shipbuilding process, memberships in an A/C group are rotated.

4.3 When and What to Check

Usually, schedules are posted for starting and finishing dates at each control station for part fabrication, sub-block assembly and block assembly. Summary sheets for future

work loads are also posted. Self checks, subsequent checks and recordings are regarded as work processes that must adhere to these schedules. A blackboard in each division of production shows the day-today status.

Normally, the master schedule for block erection weekly progress sheets and a schedule for erection checks based on the master schedule are posted in an erection office. The day-today status of block erection is maintained on a blackboard.

Accuracy checks are performed daily in accordance with schedules that are revised weekly, if necessary. Basically, the items checked for conformance with accuracy standards are

- for template preparation - overall dimensions including excess allowances and marks required for fabrication, assembly and checking work,
- for part fabrication - overall dimensions of cut plates or shapes, edge preparations, deformation, and the curvature of bent parts,
- for sub-block and block assembly - the positioning of parts or sub-blocks, their fit, gaps for welding distortion and overall dimensions, and
- for erection - fit up, gaps for welding and maintenance of hull alignment.

4.4 Information for Check Sheets

In accordance with work instructions issued by designers and based on information provided by A/C planners, members of an A/C group in a hull-construction department prepare check sheets. These designate check points and lines, checking methods, responsible personnel for meaning, and required frequency for measuring. Typical examples of check sheets are incorporated in Appendix A.

Preparing check sheets for curved blocks is usually difficult because the dimensions included in normal working drawings, while sufficient for assembly work, are not suitable for checking purposes. The simplest example are the two diagonals required for verifying the flatness of a panel. The A/C group advises loftsmen to calculate numerous other special dimensions that facilitate accuracy checks; examples of these are shown in Attachments 4, 5 and 6 of Appendix A.

Actual measurements are mainly performed as specified by the check sheets. However, check sheets cannot practically provide for all dimensions for all hull parts and assemblies. There has to be some dependence on supplementary routine checking of other dimensions by workers. This helps insure that the dimensions required by check sheets will satisfy accuracy standards. Typically, check sheets address dimensions and measuring methods as briefly illustrated in Figures 4-1 and 4-2.

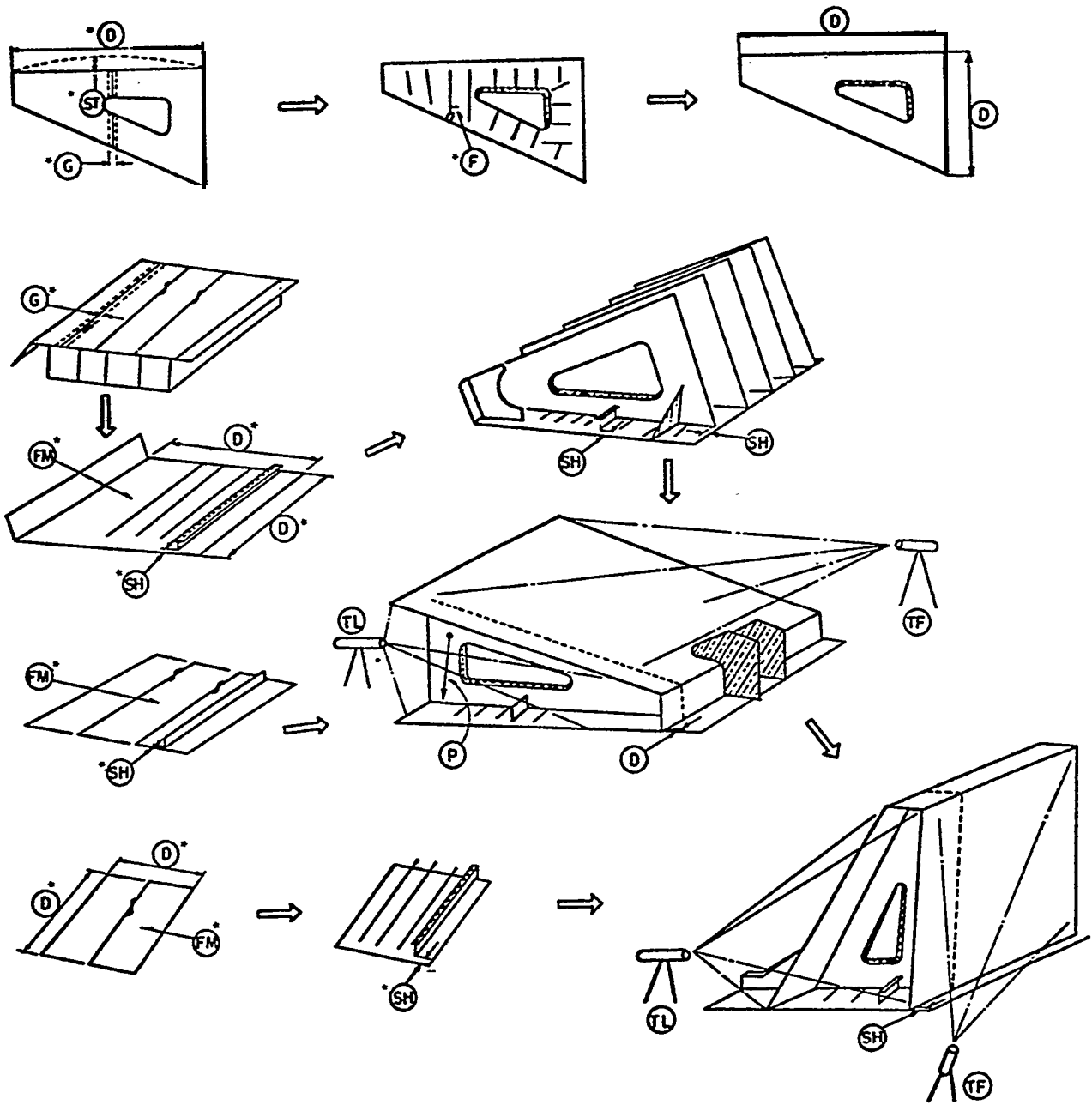
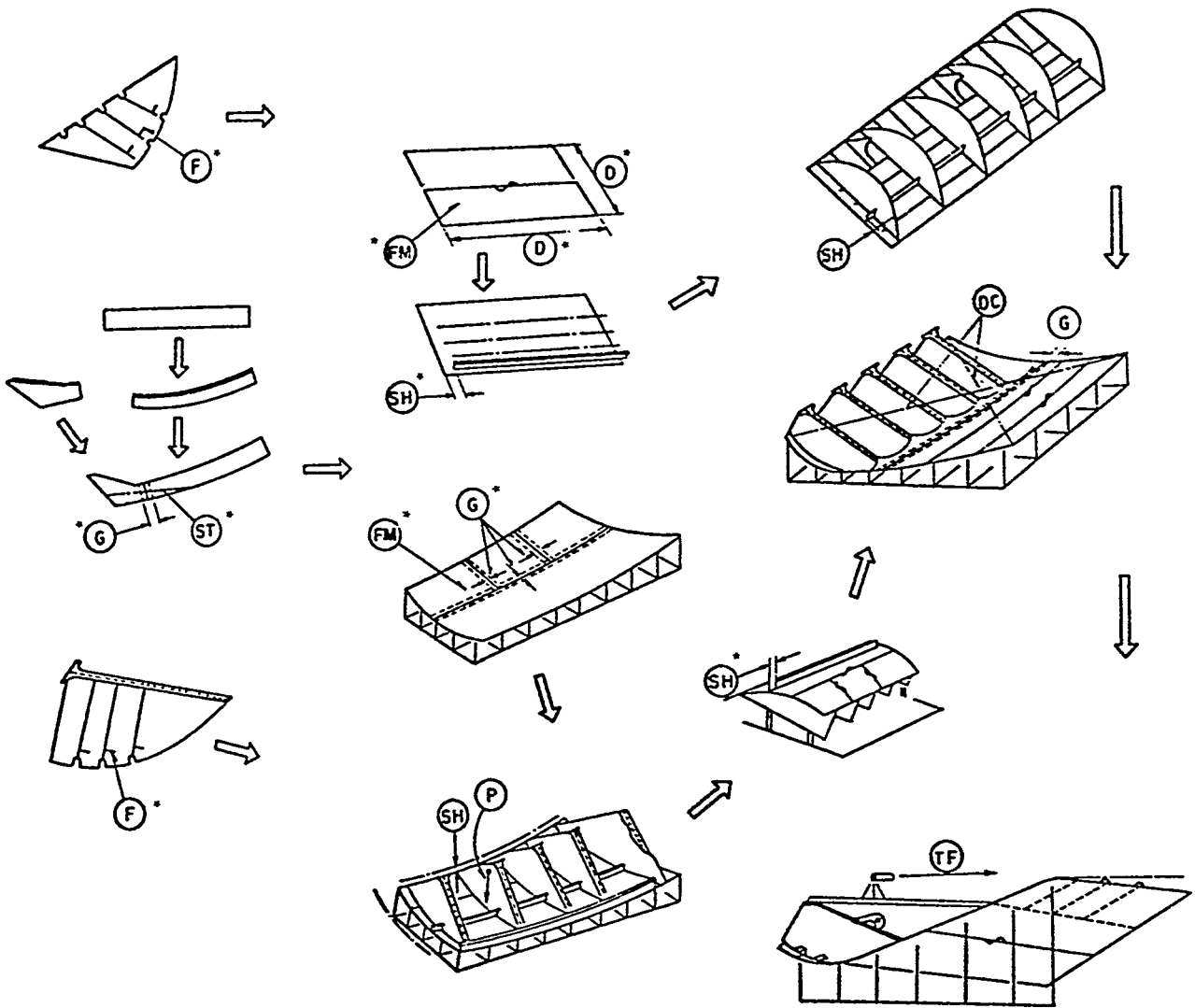

FIGURE 4-1: Dimensions and check methods that are typically W subject of check-sheet instructions for upper-wing tank parts in parallel midbody. See legend in Figure 4-2.



- D DIMENSION CHECK
- FM ASSEMBLY FINISHED MARKING
- G CHECK LINE FOR GAS CUTTING
- F GUIDE LINE FOR FITTING STIFFENERS
- ST CHECK LINE FOR DISTORTION
- SH CHECK SHIFT DIMENSION
- P PERPENDICULARITY CHECK
- TF CHECK FLATNESS BY TRANSIT
- DC CHECK DIAGONAL LENGTH
- TL CHECK ALIGNMENT AT THE END BUTT OR END FRAME

* SELF-CHECK BY WORKER

NOTE: END BUTTS CHECKED ARE ALL NEAT CUT BEFORE ERECTION

FIGURE 4-2: Dimensions and check methods that are typically the subject of check-sheet instructions for curved blocks (bilge).

4.4.1 Part Fabrication

In order to achieve specified accuracy during assembly work, each of many parts must be fabricated within specified accuracy standards. As measuring every dimension of every part is impractical, random sampling is employed to monitor accuracy tendencies. However, special or large structural parts, such as girder or transverse web assemblies are exceptions. Each should be measured meticulously per check sheet instructions with particular attention to deformation. When cutting machines, such as N/C, are employed, their maintenance is a significant factor in the uniform working circumstances which are the bases for a valid random sampling. Maintenance checks on cutting machines should be frequent and regular.

The accuracy of bent parts is critical for achieving the accuracies specified for assemblies. Inaccurately bent parts are frequently forced to fit and are the sources of internal stresses which cause deformation when welding. Thus, all crowed shell parts should be checked using sight-line templates and other information provided by loftsmen in order to establish for each plate as required

- degrees of inclination for setting the templates,
- matches of the plate edges with seam marks on the templates,
- clearances between the template edges and plate surfaces,
- transverse and longitudinal curvatures,
- twisting, and
- straightness of the sightline (see Figure 4-3).

Analogous techniques and checks apply to other parts such as twisted longitudinals.

4.4.2 Sub-block Assembly

Typically, what is important for A/C of sub-blocks is the fit of stiffeners, brackets and face plates such as on a web plate, and how to prevent and/or deal with deformation and shrinkage caused by welding. Therefore, measuring activity during sub-block assembly should concentrate on:

- checking fitting dimensions,
- checking for deformation and shrinkage by using a reference line *on* a web plate and/or a straight edge of the web plate, and
- measuring other dimensions as indicated on a check sheet.

4.4.3 Block Assembly

Achieving specified accuracy in an assembled block is most important because the block assembly process offers the last opportunity to deal with variations that otherwise have to be considered during erection.

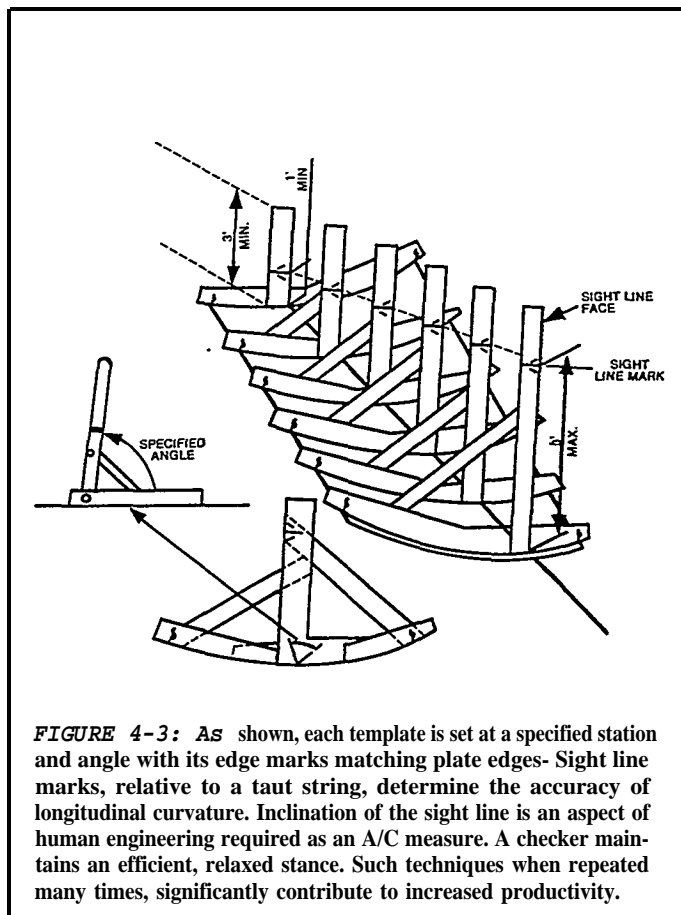

Regardless of their shapes, blocks are categorized by the panel upon which they are assembled, i.e., flat or curved. Typically the former are assembled on flat datens and the latter on pin jigs. Measurement methods for the the types are necessarily different.

Flat-block check sheets should include the following requirements:

- measurements of width, length and diagonals to be made just after the base panel is assembled,
- twisting,
- locations of sub-blocks and internal parts fitted after the base panel is completed, and
- special measurements as shown in Figure 4-4 to check unique aspects of flat blocks which incorporate some curved shell.

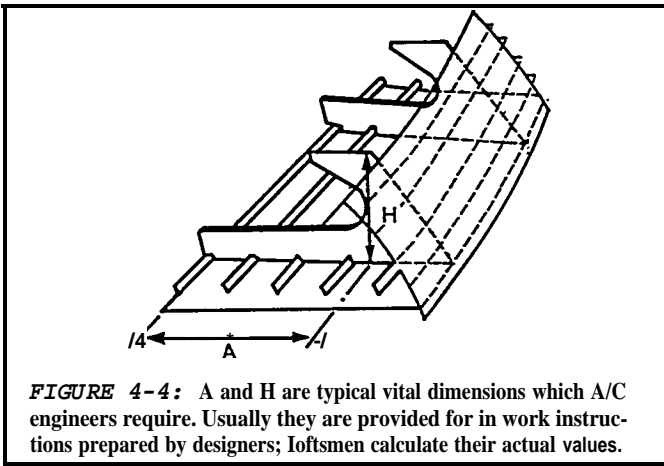

FIGURE 4-4: A and H are typical vital dimensions which A/C engineers require. Usually they are provided for in work instructions prepared by designers; loftsman calculate their actual values.

Curved-block check sheets should include the following requirements:

- measurements to check guides for precisely locating curved plates for a base panel on a pin jig,
- measurements of width, length, diagonals and chord lengths to be made just after a base panel is assembled,
- use of marked steel-tapes prepared by loftsman for checking assembly finished-marking, i.e., the location of sub-blocks and internal parts on a curved panel,

- means to verify the fitting angle of internal structure,
- instructions on how to detect and correct deformation caused by welding, and
- meticulously checking required dimensions between panel edges and the edges of internal structure particularly near erection joints.

Checking blocks as described in the foregoing is important because many are neat cut along erection joints during the final phase of block assembly.

4.4.4 Hull Erection

During the erection stage, the object is to at least achieve end-product accuracy standards specified by regulatory societies and owners for hull depth, breadth, length and straightness. WC group members monitor vital points and dimensions by measuring and recording periodically per check sheet instructions during the entire period between keel laying and launch see Figure-4-5 and Appendix A.

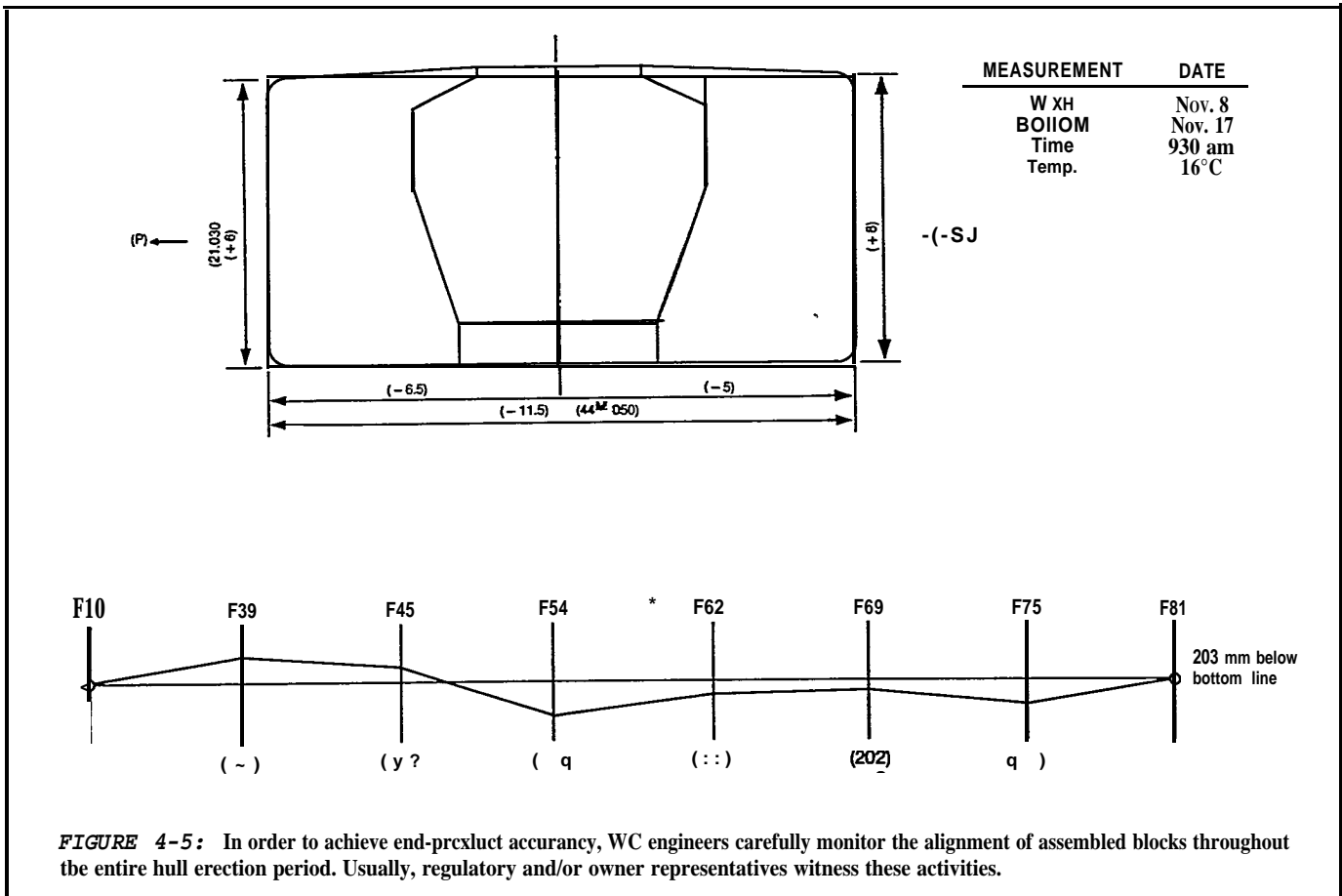

FIGURE 4-5: In order to achieve end-product accuracy, WC engineers carefully monitor the alignment of assembled blocks throughout the entire hull erection period. Usually, regulatory and/or owner representatives witness these activities.

3.0 EVALUATING

Analysis is the foundation upon which A/C is built. How to analyze is the most important prerequisite for shipyard management.

Systemized A/C analysis and feedback ensures that experiences and lessons learned are acquired by the organization and translated into improved productivity. As work progresses, all results from check sheets and reported accuracy problems are analyzed by the A/C group before they are sent to concerned organizational divisions. The evaluations include

- analysis, and
- recommendations which, as shown in Figure 5-1, are performed on either a regular or an urgent basis.

Regular analysis is employed during a number of phases, even during start-up. Typical regular analysis functions include

- determining normal performance by process flow or work stage during start-up and following changes in work methods,
- establishing \bar{x} -R control charts per process flow or work stage,
- monitoring work performance per process flow or work stage, using a pre-established sampling plan,
- writing and evaluating variation merging equations, based on design details, work sequences, a block plan, etc., and
- analyzing, employing normal work performance data and variation merging equations, for identifying specific process flows or work stages which if modified would further improve productivity of the entire manufacturing system.

Urgent analysis takes place when sampling indicates that an interim product is not within tolerance limits and therefore has the potential to disrupt ensuing work. Urgent analysis is used to quickly determine the best remedial action, e.g., immediate rework and rescheduling of succeeding work within limits imposed by an erection schedule, providing compensation by changes in design details or work processes for other interim products, and/or initiation of overtime work.

5.1 Regular Analysis

Once an A/C system is in place and functioning, monitoring work performance per processor stage simply involves random sampling and plotting of results on control charts. Workers and first-line supervisors monitor the charts to watch for changes in work performances. Analysis of control charts beyond identification of special causes of variation is adequately covered in literature describing statistical quality control.¹

If an analysis discloses an apparent area for improvement an A/C engineer pursues one or more typical options as follows:

- more detailed investigation of the data,
- investigation of instruments used for measuring,
- verification of alignment of facilities such as platens for flat-block assembly and cribbing for erection,
- review of review methods, and
- study of specified amounts for excess.

Workers perform self checks daily to insure compliance with accuracy standards. These are again checked and recorded by their work leaders. Properly collected data, even if all measurements are within accuracy standards, are used to identify the characteristics and tendencies of variations. Such knowledge leads to further improvement in production processes. An example of data collection and analysis for determining excess allowances is included in Appendix E.

Feedback of analyzed A/C data is vital because it encourages planners to review matters such as:

- whether schemes for amounts of excess, vital points and dimensions, etc., were satisfactory,
- whether block divisions and shell straking were optimum,
- whether work-process standards were suitable, and
- whether sufficient work instructions were provided.

See, for example, "Introduction to Statistical Quality Control; by D. C. Montgomery, John Wiley & Sons, 1985.

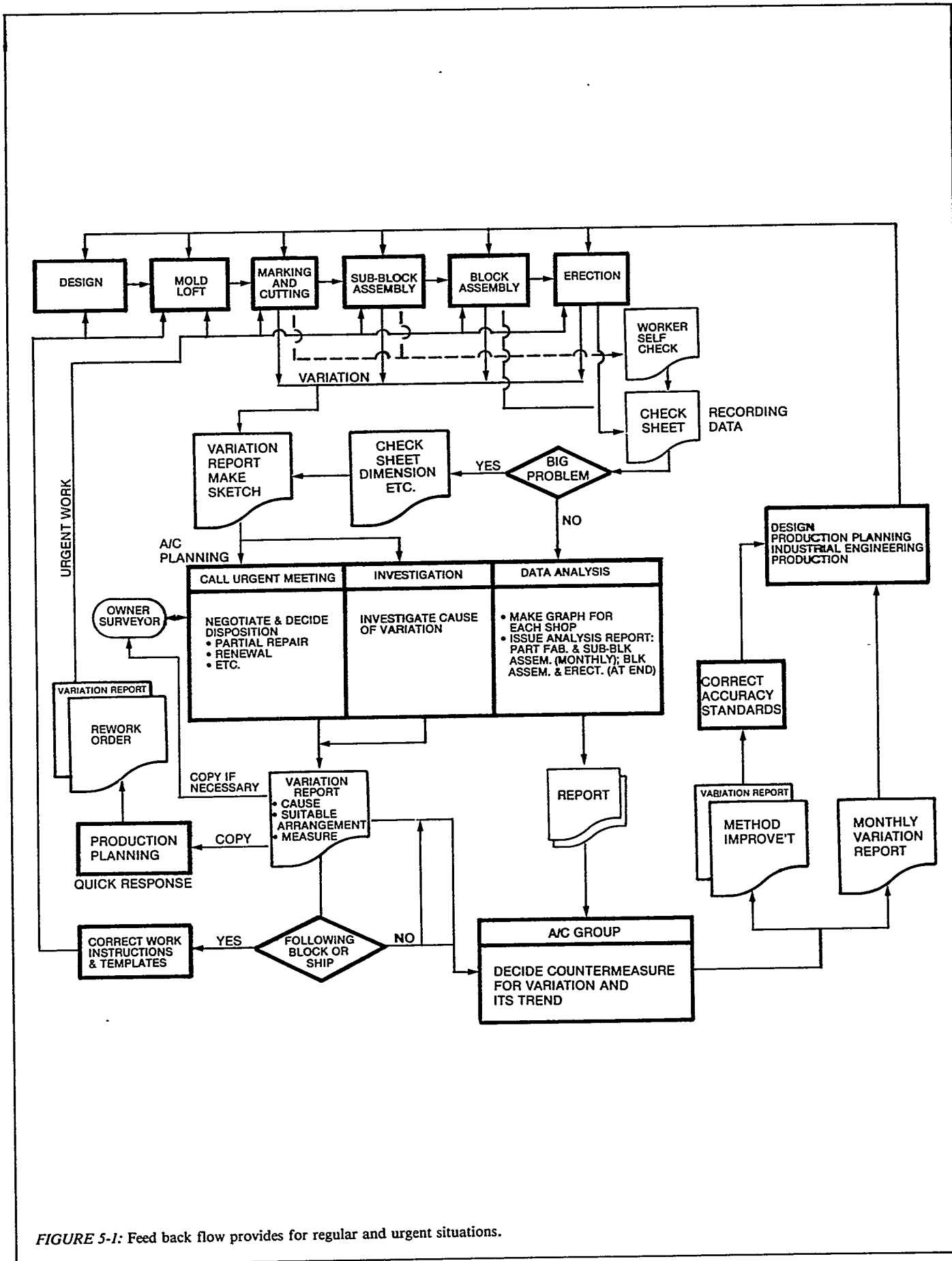

FIGURE 5-1: Feed back flow provides for regular and urgent situations.

5.1.1. Significance of Mean Value

For most work processes, the mean value for variations is planned to be zero. If the actual mean value differs from zero, it should be changed to match results of the work process or the work process should be changed so as to yield the planned mean value (zero). The following examples apply:

- **Example 1:** Consider a particular dimension for panels, such as for a longitudinal bulkhead under a tank top, which were cut with some allowance for shrinkage. After welding during sub-assembly work, the mean value of the dimension was determined to be negative, i.e., some shortage exists compared to the planned zero value.

Analysis: Check kerf compensation; if sufficient, the allowance for shrinkage was too small.

Remedy: Add the absolute mean value to the previously planned allowance for shrinkage.

- **Example 2:** Near the end of flat-block assembly, checking discloses that plates in tank-top panels are deformed at their centers with a mean value of 1/2 inch.

Analysis: Check the level of the platen on which the flat blocks were assembled.

Remedy: If the platen is true, improve the assembly work processes, e.g., apply pre-tensioning or change weld sequences.

5.1.2. Significance of Standard Deviation

Standard deviation is significant for a number of reasons. It provides linkage between the accuracies of earlier work processes and the accuracy of a final process through the theorem of addition of variance. Without this relationship, analytical A/C does not exist.

Further, during analysis A/C engineers are very watchful for a change or shift in the standard deviation for each work process. Such behavior could indicate that something about how a work process is executed has changed. Many reasons exist including a worker perfecting a better technique which should be adopted by others and erratic operation of or deteriorating machinery.

- **Example:** The standard deviation for the length of manually fabricated longitudinals suddenly increases, decreases or shifts.

Analysis: Examine how and by whom the longitudinal were fabricated. Methods, particularly sequences, should be thoroughly analyzed.

Remedy: There could be many solutions dependent upon results of the detailed analysis. At least one shipbuilder reacted by finish cutting longitudinals before bending, i.e., end-margins to permit grasping for bending at the ends, were eliminated. Following the mechanical bending process, line heating was introduced to bend the finish-cut ends. Accuracy was improved and the wasteful margins were eliminated.

5.1.3. Setting Accuracy Standards

Data analysis quantitatively sets accuracy standards. For example, when erection joints are aligned the achieved distribution of gap variations will, at the extremities of the distribution, show requirements for rework

- cutting where a gap is too small or negative, or
- building on an edge where there is too much gap.

As shown in Figure 5-2, when G_0 is less than O , minimal material is cutoff to achieve the gap G because it is cheaper to retain as much of the original material as possible. When G_0 is more than O , a minimal amount is built-up to achieve the gap G_w because the buildup process is expensive. Thus, G_0 is always smaller than G_w .

The condition for avoiding rework is: $G_0 \leq G \leq G_w$

Therefore, by definition the lower tolerance limit is G_0 and the upper tolerance limit is G_w . A standard range to be used as a goal for improving accuracy is established accordingly; see Figure 5-3.

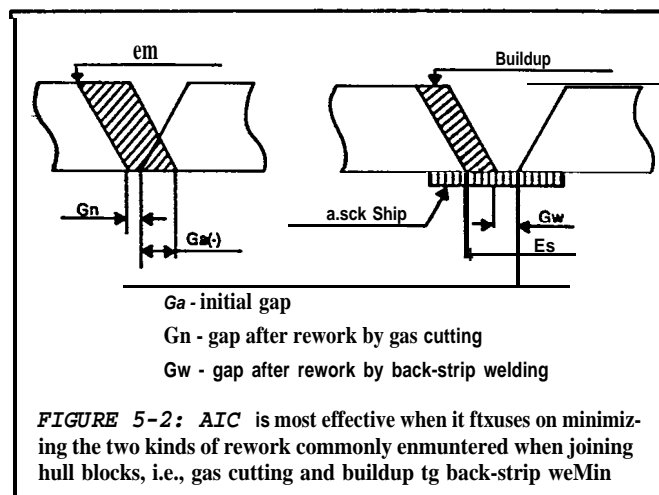

FIGURE 5-2: A/C is most effective when it focuses on minimizing the two kinds of rework commonly encountered when joining hull blocks, i.e., gas cutting and buildup to back-strip welding.

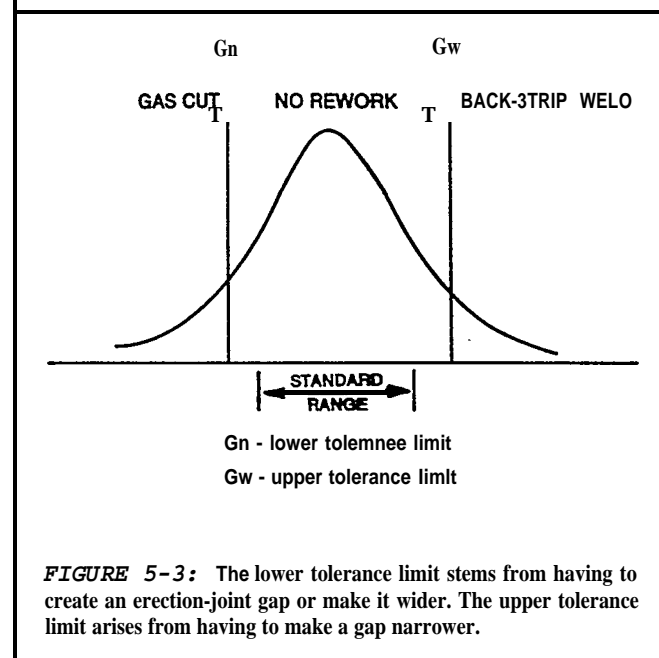

FIGURE 5-3: The lower tolerance limit stems from having to create an erection-joint gap or make it wider. The upper tolerance limit arises from having to make a gap narrower.

5.1.4. Modifying Distributions

Consider traditional rework for adjusting erection gaps. Cutting dominates because *experienced* people know that cutting costs per lineal measure are less than costs for build-up by back-strip welding per lineal measure. The mean value of the pertinent distribution of gap variations favors the lower tolerance limit accordingly. Figure 5-4 shows this intentional bias and also shows the impact of shifting the mean value toward the upper tolerance limit.

Because of the nature of normal distributions, the nominal increase in back-strip welding is overwhelmingly offset by the substantial decrease in cutting required. Further, the prospects for exceeding the lower tolerance limit are reduced. Thus, analytically derived goals proposed by A/C engineers will sometimes differ from those adhered to by traditionalists who operate without the benefit of carefully collected and analyzed data.

In shipyards where A/C is practiced, operations managers benefit from detailed reports of productivity during hull erection which relate total lengths of gas cutting and back-strip welding to the total lengths of erection gaps. In an actual report for erection of a 167,500 DWT tanker, Figure 5-5, rework was only required for 32.6% of total gap lengths. That is, 67.4% which had been neat cut was already within tolerances for semiautomatic or automatic erection welding.

A similar report for a 32,000 DWT bulk carrier, Figure 5-6, shows that rework was required for 38.7% of total gap lengths. This higher rework figure is due to the smaller ship having relatively more shape. The actual gap widths achieved and the locations of rework by gas cutting and buildup by back-strip welding are shown in Figure 5-7.

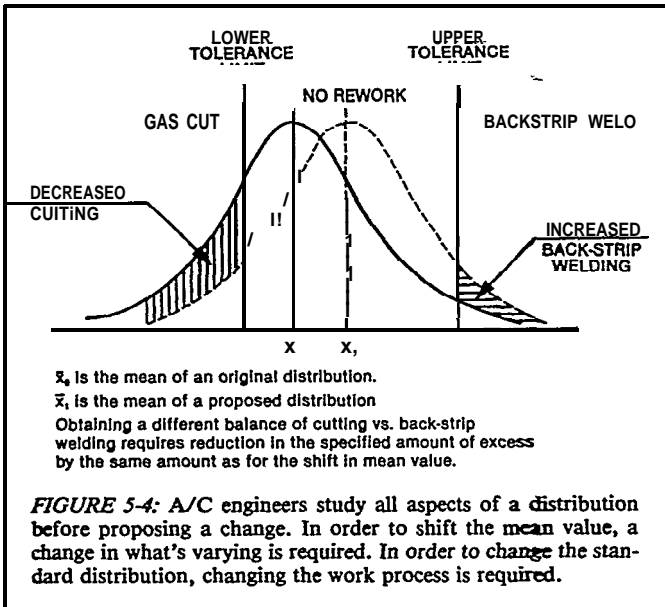

ANALYSIS REPORT FOR HULL ERECTION TANKER

	Erection Gap Length (M)	Gas Cutting		Back-Strip Welding		Rework (%)
		Length (m)	%	Length (m)	%	
Upper Deck	1,548.2	452.3	27.4	65.6	4.2	31.6
Side Shell	797.8	203.8	25.5	53.2	6.6	32.1
Longitudinal BHD	652.2	324.0	49.6	34.0	5.2	54.8
Tank Top	431.8	27.3	6.3	17.5	4.0	10.3
Bottom Shell	1,453.7	344.8	23.7	102.5	7.0	30.7
Total Hull	4,883.7	1,325.2	27.1	272.8	5.5	32.6

Gas cut When surplus was 3 or more mm
 Back-strip weld When gap was 5 or more mm too wide

Length 281M
 Breadth 48M
 Depth 28.2M
 Dead Weight 167,500 Tons
 Launching April 12, 1977

FIGURE 5-5: An analysis report for hull erection is prepared at the end of each project. Final data organized as shown is a "report card" of the hull construction department's productivity. Reports such as this one and separate cost returns for rework, hasten traditional shop managers' acceptance of A/C.

ANALYSIS REPORT FOR HULL ERECTION BULK CARRIER

	Erection Gap Length (m)	Gas Cutting		Back-Strip Welding		Rework %
		Length (m)	%	Length (m)	%	
Upper Deck	345.6 (326.0)	163.2 (143.6)	47.2 (44.0)	31.4	9.1	56.3
Shell	1,660.4 (1,476.8)	380.7 (197.1)	22.9 (13.3)	287.2	17.3	40.2
Tank Top	396.0 (396.0)	58.6 (58.6)	14.8 (14.8)	8.8	2.2	17.0
Total Hull	2,402.0 (2,198.8)	602.5 (399.3)	25.1 (18.2)	327.4	13.6	38.7

Gap Tolerance Limits:
 4-7 mm for CO₂ semi-automatic arc welding
 12-23 mm for electro-gas arc welding
 0-6 mm for submerged arc welding with application of one side welding process

Length 171 m
 Breadth 30.5 m
 Depth 15.3 m
 Dead Weight 32,000 Tons
 Launching October 5, 1984

FIGURE 5-6: An analysis report for a smaller ship than the one for which Figure 5-5 is applicable. Relatively, there is a greater amount of hull curvature. Thus, a higher percentage of rework is indicated. Note, for example, that the total length for Erection Gap is 2,402.0 meters. The number immediately below in parentheses, 2,198.8 meters, is the total length of Erection Gap which was the objective of statistical analysis. The difference, 203.2 meters, accounts for gaps in radical curvature for which margins were employed. Thus, only 8.5% of the Erection Gap total, was precommitted to rework.

BOTTOM AND SIDE SHELL

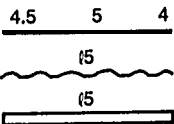
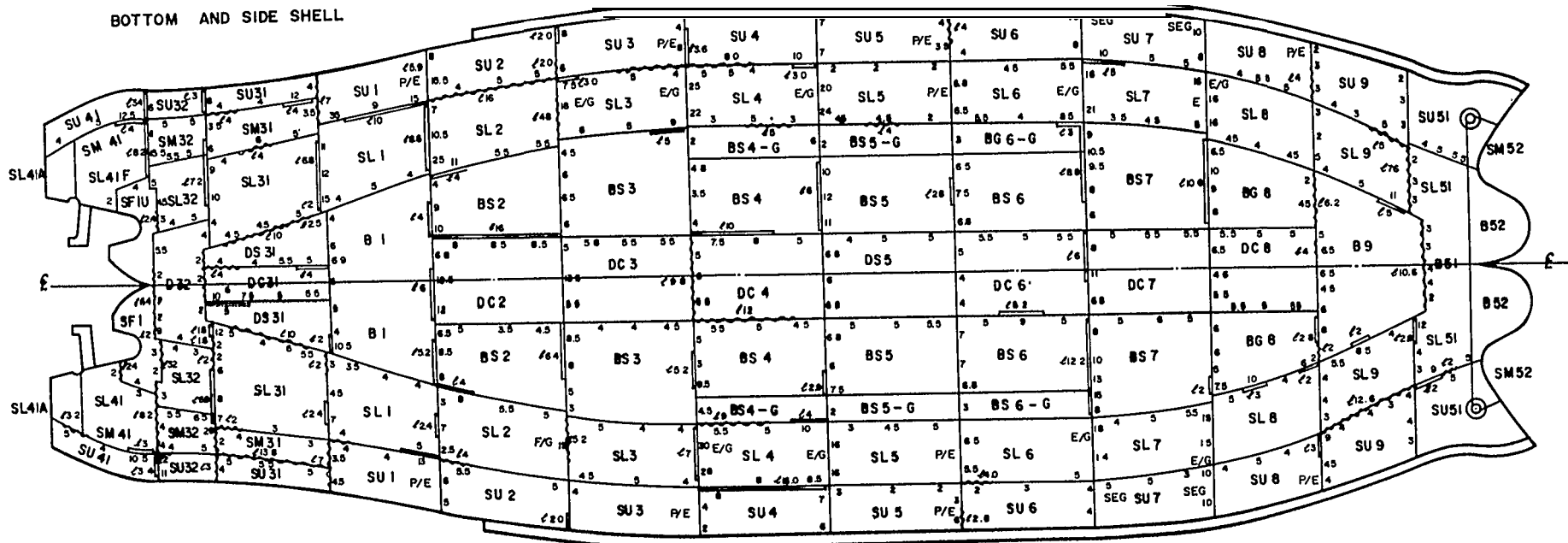

gap widths in mm, some after gas cutting

..... gas cutting over a 5 m length
 back-strip welding over 5 m length

- E/G — Erection of side-shell butt by Electro-gas Arc Welding
- P/E — Pre-erection of side-shell butt by CO₂ Welding (joining blocks to create grand blocks)
- SEG — Simple Electro-gas Arc Welding (portable) for vertical butts less than 5 meters long in relatively thick plate.

FIGURE 5-7a: Analysis reports are accompanied by a chart of butts and seams, as illustrated, showing the degrees of problems encountered, their locations and the countermeasures taken.

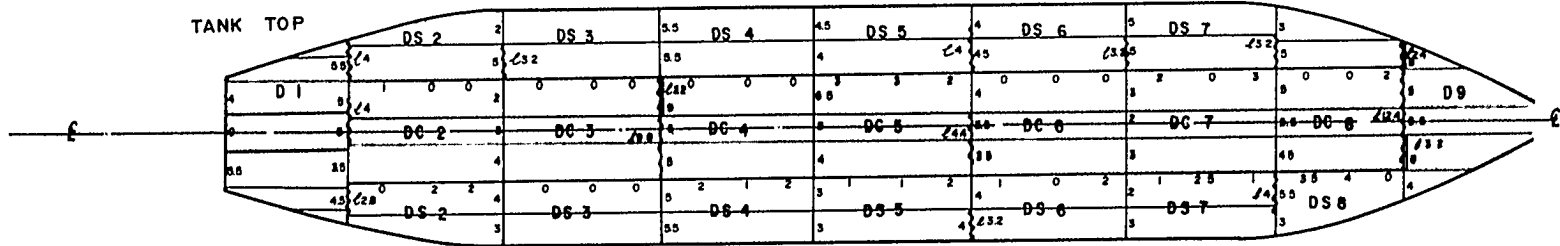
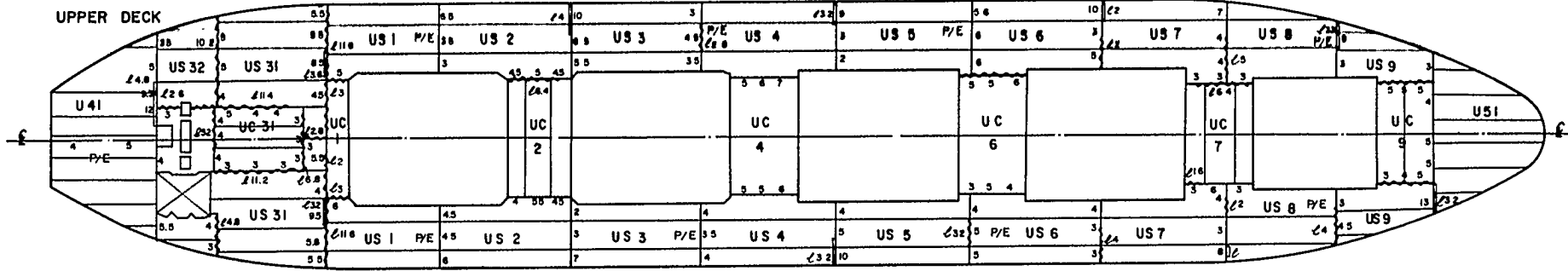

FAB — Flux Asbestos Backing method is applied to tank top seams.

FIGURE 5-7b: Charts showing where rework was performed on a completed ship comprise feedback needed for A/C planning of ships to be built.

5.1.5 Sequence for Analysis

Ongoing review of accuracy standards by continuously analyzing data is very important. The following procedure for analysis of data obtained during flat-block assembly is typical:

- prepare separate histograms of variations for each characteristic, e.g., length, width, etc., as shown in Figure 5-8,
- calculate the mean value, \bar{x} , and standard deviation, s , for each characteristic,
- use each standard deviation to determine how the data conforms to its pertinent standard range, e.g., competitive shipbuilders define standard range as $\bar{x} \pm 2s$,
- when the data for a characteristic does not conform with its standard range ($X+2S$ means conformance with 95 % probability), A/C engineers:
 - confirm that the standard range is appropriate, investigate and make necessary recommendations, e.g., adjust excess allowance, change methods, supplement worker training, etc., or
 - propose changes in the standard range which do not impact on end-product tolerances.

Appendix E contains a good example of a sequence for analysis.

5.2 Urgent Analysis

In real shipbuilding circumstances no one can eliminate variations which require rework. Moreover, no one can predict exactly when they will occur. Disruption is also caused by the effects of such things as errors, accidents and weather abnormalities, which differ from variations because their occurrences do not adhere to normal distributions. Despite their erratic natures they too require organized responses and analyses in order to:

- identify short-term or temporary solutions which minimize disruptions, and to subsequently,
- achieve permanent means to prevent reoccurrence.

The feedback path for these urgent considerations is included in Figure 5-1.

One shipbuilder's preplanned response to a *serious* inaccuracy immediately summons select members of the A/C group. This trouble-shooting team of specialists for planning, executing and evaluating, meet where the inaccuracy exists to:

- evaluate impact on work flow,
- recommend what, how, where and when rework is to take place so as to minimize disruption, and
- collect evidence for identifying the cause.

Reportedly, the average time for such meetings is short; for the most extreme problem two hours could be required.

After the temporary countermeasures for quickly restoring work flow, investigations continue for the purpose of devising permanent solutions. Usually, work procedures are revised to reflect more A/C philosophy.

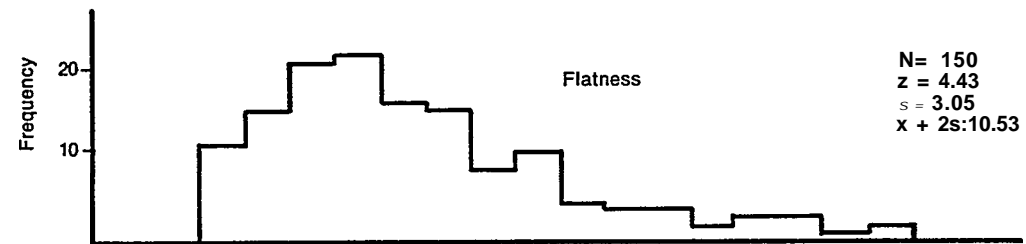
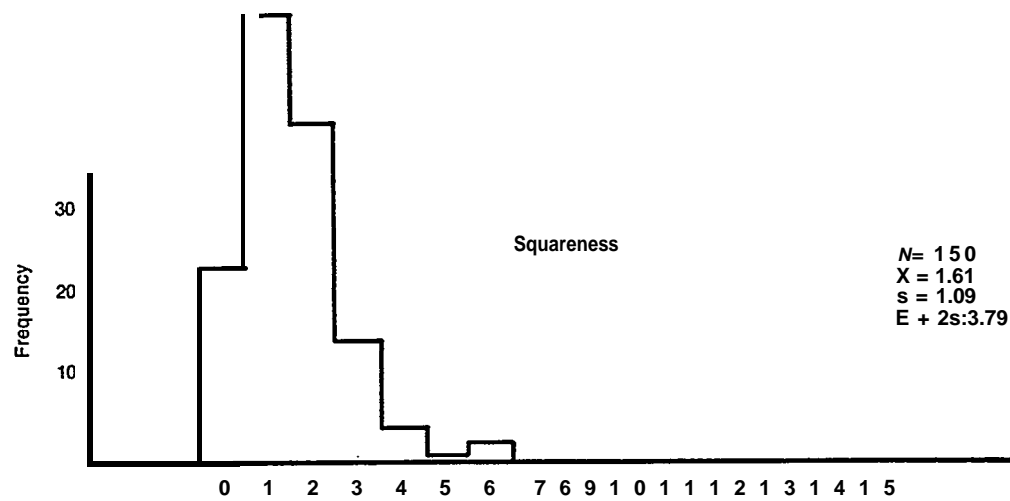
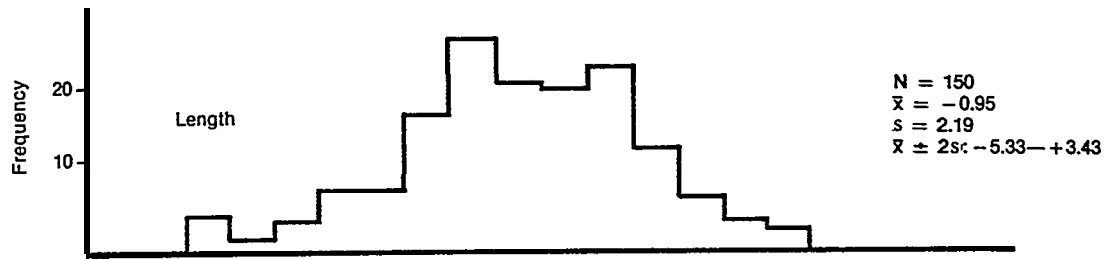
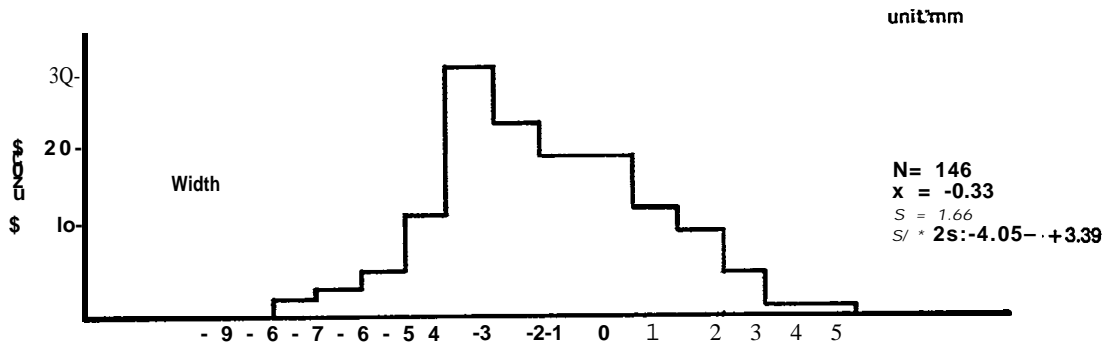

FIGURE5-8: Each histogram of variations in flat blocks compares identical parameters. Regarding squareness and flatness only absolute values are of concern. Appendix B contains more information about preparing histograms.

Stage	Regular Control Rem	Measurement Frequency	Sample	Standard Deviation
Template Production	Tape	Week	20	0.4
	Paper Template	20 Days	8	0.5
	Tin Template	20 Days	8	0.4
	Wood Template	20 Days	8	0.5
Part Fabrication	Cuttin Mate by Flame planer-Width	Day	8	0.4
	Cutting Plate by Flame planer-Straightness	Day	All	
	Finish Marking plate Length	Day	All	
	Finish Marking Plate Main Marking Line	Day	All	
	Finish Marking Plate Right Angle	Day	All	
	Bevel Angle for Auto Welder	10 Days	8	1.0
	curved Plate Marking	Day	8	0.8
	Cutting Accuracy of Curved Plate	Day	8	0.8
	Shape Marking	Day	8	0.5
	Cutting Accuracy of Shapes	Day	8	0.8
	N/C Cutting Machine Plate Width	Day	8	0.6
	N/C Cutting Machine Plate Length	Day	8	0.5
	Cutting Accuracy of Internals e.g. Floor Girder in a Double Bottom	Day	8	0.8
	Cutting Accuracy	Day	8	1.5
	Accuracy of Fitting Stiffner	Day	8	0.7
	Sub-Block Assembly	Straightening Deformation by Line Heating	Day	6
Accuracy of Fitting Face Plate		Day	8	0.8
Accuracy of Fitting Angle		Day		1/200
Block Assembly	Plate Length	2 Days	8	1.4
	Plate Width	2 Days	8	1.5
	Right Angle (Difference between Diagonals)	2 Days	8	12
	Reference Line	2 Days	8	0.8
	Position of Longitudinal Edge	2 Days	8	1.2
	Position of Transverse End	2 Days	8	1.5
	Accuracy of Through Piece	2 Days	6	1.5
	Accuracy of Curved Shell Web	2 Days	6	5/1000
	Curved Shell Plate-Length (After Cutting)	3 Days	4	1.5
	curved shell Plate-Width (After Cutting)	3 Days	4	1.5
Curved Shell Plate-Reference line (After Cutting)	3 Days	8	0.8	

FIGURE 5-9: Regular Control Items.

5.3 Control

Controls which assure that achieved accuracy conforms with an A/C plan for hull construction, is prerequisite for competitive shipbuilding. They are classified as *regular* or *special*.

Because of the many different parts and subassemblies that are required, regular controls are applied to *repetitive work processes*. Typical regular control items in an ongoing A/C program, including their measurement frequencies, sample sizes and standard deviations, are listed in Figure 5-9. A control chart for such regular usage is shown in Figure 5-10. Such charts are maintained by A/C engineers for production control purposes. Once people become used to them, they provide guidance to everyone concerned, i.e., workers and their supervisors. Thus, each such control chart is posted at its respective work station. This is important. Descriptions of the types of control charts used for A/C by shipbuilders and how to prepare them, are in Appendix F.

Special controls are based upon the accuracy condition of a hull upon completion. Necessary vital points are defined and included in the A/C plan for a specific hull. When the hull is completed, members of the A/C group accumulate and analyze measurements that relate to predetermined vital dimensions. They look for accuracy trends which should be modified for further productivity improvements.

Use of variation merging equations permits prediction of *probable* erection gap accuracy as described in Figure 3-4. However, more information is needed in order to predict the locations of and amounts by which gaps are out of tolerance for semiautomatic or automatic erection welding. With such predictions, rework is planned accordingly. The decisions made include where and when rework shall take place. e.g., gas cutting could be performed by either assembly shop or erection shop workers dependent on circumstances.

Measurements needed for rework planning are made after block assembly to determine how block widths and lengths vary from design dimensions. Organizing such as-built measurements, as shown in Figures 5-11 and 5-12, is sufficient input for some very experienced A/C engineers to make rework decisions. Others find it helpful to employ position Dimension Diagrams (P/Ds) for checking gap accuracy achieved against accuracy needed to facilitate erection welding.

\bar{x} - R CONTROL CHART

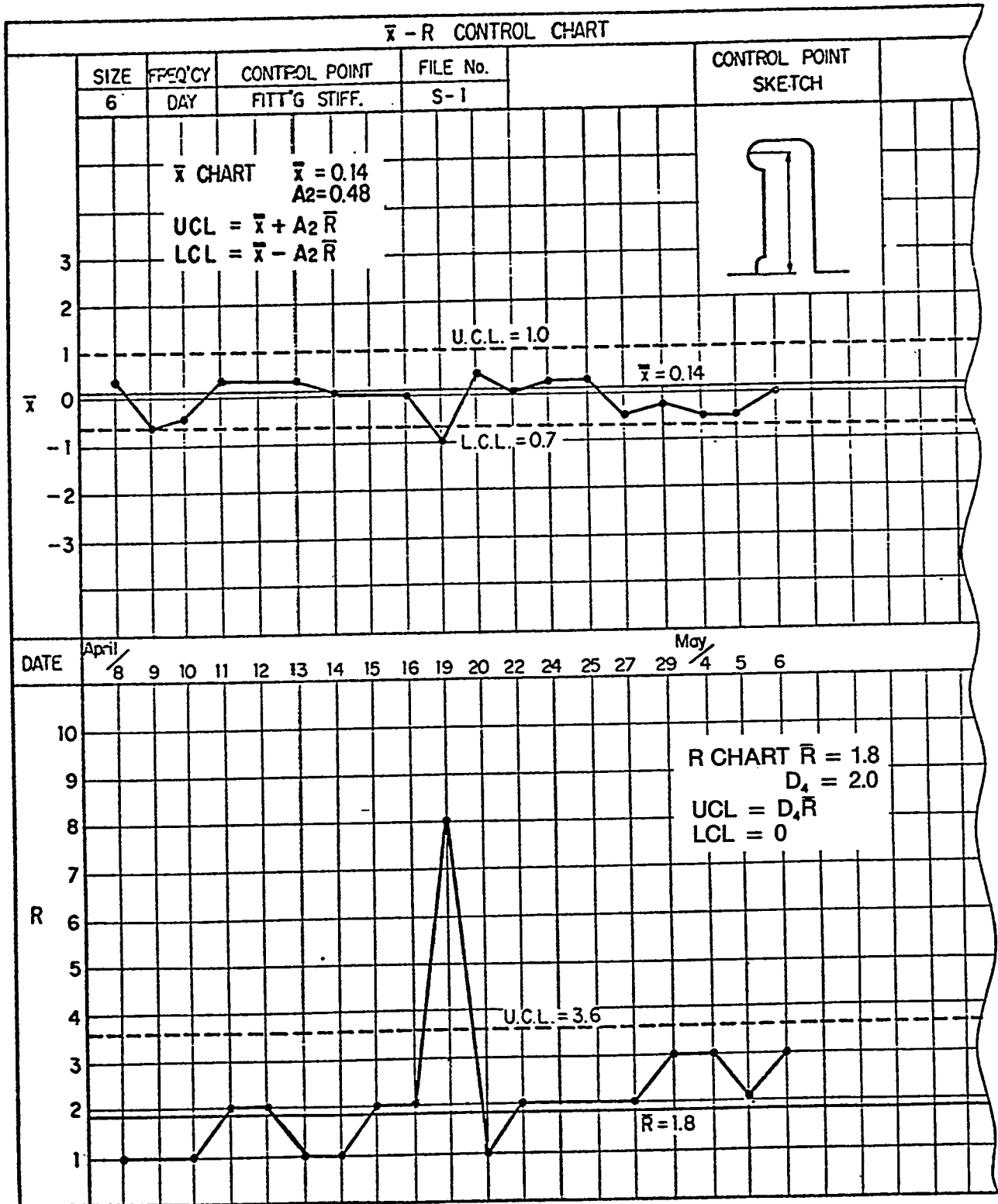
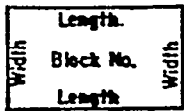

FIGURE 5-10: The \bar{x} chart shows that on 19 April some measurements caused the mean value to drop below the lower control limit. The R chart shows a sudden increase in range for the same day. The two facts considered together indicate that a few dimensions were short by large amounts. \bar{x} -R charts for A/C are the same as used for quality control theory. How they are prepared is described in Appendix F.

16S4	15S4	14S4	13S4	12S4	+6 11S4 +3	10S4	+5 9S4 +2	8S4	7S4	6S4	5S4	P	
			+3	+3	+2	+1	+1	0					
16S2	15S2	14S2	+2	+4	-2	+2	-3	0				P	
			13S3	12S3	11S3	10S3	9S3	8S3	7S3	6S3	5S3		
16S1	15S1	14S1	+3	+2	+4	+3	+2	+3	+1	0	+2	+3	P
			13S2	12S2	11S2	10S2	9S2	8S2	7S2	6S2	5S2		
16S2	15S2	14S2	+2	+3	0	0	-1	+3	+1	+2	+2	+3	P
			13S1	12S1	11S1	10S1	9S1	8S1	7S1	6S1	5S1		
16S4	15S3	14S3	+2	+2	+1	-2	+1	+1	+2	+3	-1	+4	P
			13S2	12S2	11S2	10S2	9S2	8S2	7S2	6S2	5S2		
16S4	15S4	14S4	+1	+2	+2	+3	+3	+3	+1	+3	+3	+1	P
			13S3	12S3	11S3	10S3	9S3	8S3	7S3	6S3	5S3		
16S4	15S4	14S4	+3	+4	+3	+2	+2	+2	+1	+6	+2	+4	P
			13S4	12S4	11S4	10S4	9S4	8S4	7S4	6S4	5S4		
												S	



- Measurement made after block assembly
- Figures indicate variations from design

FIGURE 5-11: Knowledge of variations in each block is needed to plan rework required before hull erection.

Fore or Aft Longl. No.	Block No.		D1			D2			D3			D4			D5			D6			D7	
	F	A	F	A	G	F	A	G	F	A	G	F	A	G	F	A	G	F	A	F	A	
	Sup Opp		Opp Sup		Opp Sup		Opp Sup		Opp Sup		Opp Sup		Opp Sup		Opp Sup		Opp Sup		Opp Sup		Opp Sup	
10																						
9			0	0	0	0	0	0	0	0	+2	+2	0	0	0	0	0	0	0	0	0	0
Gir. 8		0	0	0	-1	0	+1	-1	-1	0	0	0	0	0	+6	+6	0	0	0	0	+1	
7		0	+1	+1	-1	-1	0	0	0	0	+1	0	-1	0	0	0	-2	-2	0	0	+1	
6		+1	+1	0	0	0	0	-1	-1	0	0	-1	-1	0	0	0	0	0	0	0	+1	
5		0	+1	+1	0	0	0	+1	+1.5	+0.5	-1	-1	0	0	0	0	-1	-2	-1	+2		
Gir. 4		-1	0	+1	0	0	0	0	+0.5	+0.5	-1	0	+1	0	+1	+1	-1	-1	0	+2		
3		-1	0	+1	0	0	0	0	+1	+1	-1	-1	0	0	0	0	-1	-1	0	+1		
2		0	0	0	0	0	0	-1	0	+1	-1	-1	0	0	0	0	0	0	-1	-1	+2	
Gir. 1		-1	0	+1	+1	+1	0	-1	0	+1	-1	0	+1	0	+3	+3	0	0	0	+2		
1		-1	-1	0	0	+1	+1	-1	0	+1	0	0	0	0	+2	+2	+1	+1	0	+2		
Gir. 1		-2	-1	+1	-1	-1	0	-1	-1	0	-1	-2	-2	+1	+1	0	0	-1	-1	+3		
2		-1	0	+1	-2	-2	0	-1	-1	0	0	0	0	+2	+1	-1	0	0	0	0		
3		0	0	0	0	0	0	0	+0.5	+0.5	-1	+1	0	0	0	0	0	-1	-1	+4		
Gir. 4		0	0	0	0	+0.5	+0.1	-2	-2	0	0	+1	+1	-2	-1	+1	+1	+1	0	+2		
5		0	+1	+1	-1	-1	0	0	0	0	-1	-1	0	0	0	0	0	0	0	+5		
6		0	0	0	+1	0	-1	-1	-1	0	-2	-2	0	0	0	0	+1	+1	0	+3		
7		0	0	0	-1	-1	0	-1	0	+1	0	0	0	0	0	0	0	0	0	+3		
Gir. 8		0	0	0	0	+2	+2	-1	-1	0	0	0	0	-1	0	+1	0	0	0	+3		
9					0	0	0	0	0	0	+2	+2	0	0	0	0	0	0	0	0		
10																						
OUT CORRECTION (Over 3mm)																			6			
BACKING STRIP CORRECTION (Over 5mm)																	2					

FIGURE 5-12: Knowledge of accuracy achieved for the ends of girders and longitudinals in each block is needed to plan rework required before hull erection.

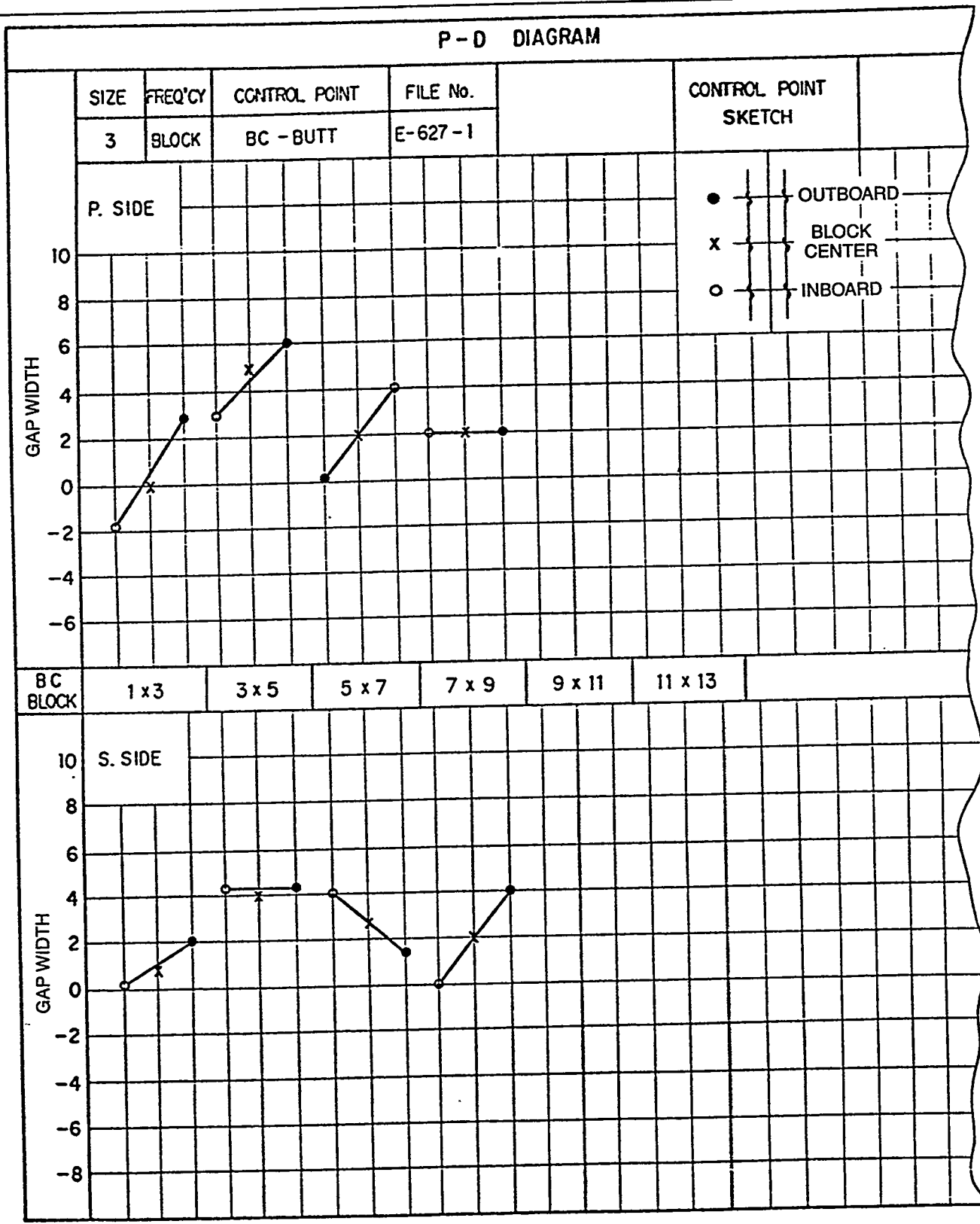

FIGURE 5-13: Position/Dimension Diagrams (P/Ds) are used by some A/C engineers to plan rework needed after block assembly as further preparation for automatic erection welding. Each plot on a P/D shows the gap width that would be achieved if blocks were landed per an erection plan without rework. With reference to the bottom center (BC) block arrangement in Figure 5-14, the P/D shown above is only for butt joints. The notation "1 x 3" above, for example, designates the butt gap between blocks BC1 and BC3, port and starboard. A plot showing negative gap width, indicates overlap.

An A/C engineer uses a P/D to focus on just the narrow zones which encompass gaps between a series of blocks. For example, the P/D shown in Figure 5-13 is for the butts between blocks arranged as in Figure 5-14. Similar presentations are made for seams between blocks.

The information used for a P/D is based upon an examination which requires obtaining a best fit of as-built widths and lengths to design dimensions. With each block in its best-fit-to-design mode, its variations from design butts are calculated. The combined variations of two blocks from a common design butt is then plotted on a P/D.

When less accuracy is sufficient, assumption is made that the reference line marked 50 millimeters (mm) back from and parallel to a butt cut line during panel layout, will remain parallel to its *design* butt during block assembly. Thus, when the reference lines astride a gap are parallel and 100 mm apart, the variations from each reference line to its corresponding actual cut, are summed. Subtracting the sums so obtained from 100 mm yields the gap widths needed for a P/D. The foregoing is based on a goal of zero gap width. If, for example, a minimum gap of 2 mm is satisfactory for a particular welding process, then 102 mm should be substituted for 100 mm.

A P/D gives an explicit view of block accuracies insofar as they affect erection welding. Thus, a P/D facilitates planning effective rework to further the application of semiautomatic or automatic welding. With reference to the P/D shown in Figure 5-13, the following evaluations, countermeasures and remedial actions are typical:

- Butt gaps between starboard side blocks are all within tolerance limits for welding. No countermeasures or remedial actions are required.
- Between port side blocks BC1 and BC3, overlap of -2 mm is indicated for the gap inboard and an opening of 3 mm is indicated for the gap outboard. If the upper tolerance limit for welding is 5 mm, gas cutting could be avoided by shifting port side block BC3 forward by 2 mm. However, gas cutting from the inboard end to very near block centerline to remove the overlap is preferred.
- For an upper tolerance limit of 5 mm for welding, the gap outboard between port side blocks BC3 and BC5 is excessive. Buildup by back-strip welding could be avoided by shifting block BC5 aft by 2 or 3 mm. However, buildup by back-strip welding of at least 1 mm from the outboard end to the block centerline is preferred.

In principle, adjusting insufficiently accurate erection gaps is more effective than shifting a block from its best-fit-to-design position. Shifting a block entails shifting frame lines when addressing butts and shifting block centerlines when addressing seams so as to adversely affect the alignment of other blocks.

Further to the countermeasures described in the foregoing, an A/C engineer will associate out of tolerance gaps with particular blocks, e.g., the forward edge of port side block BC3 and aft edge of port side block BC5. Then investigation will be made for inaccurate marking and/or cutting devices or methods. Afterwards, dependent on findings, plans are devised for improving methods and devices, retraining workers, etc.

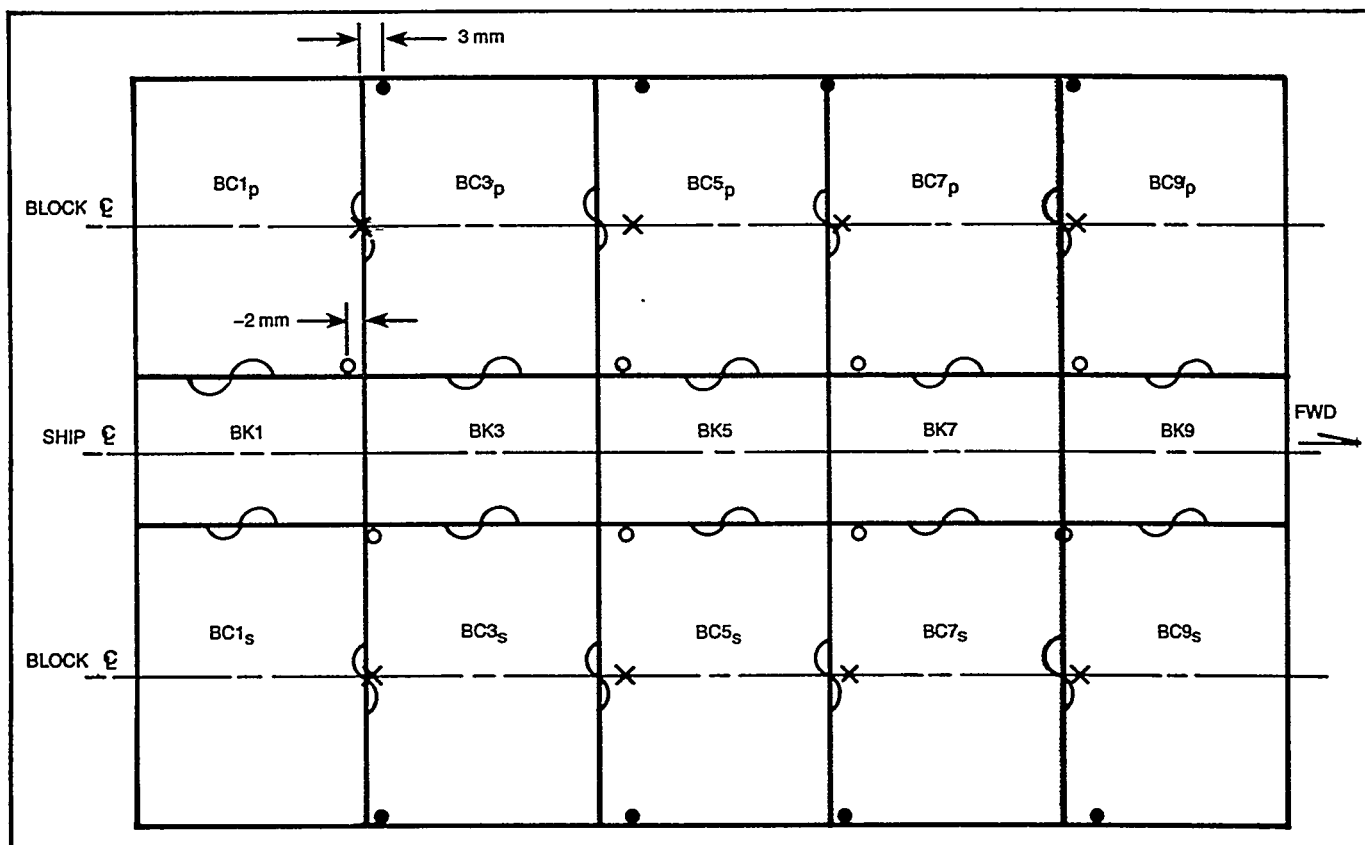

FIGURE 5-14: The arrangement of just the bottom center (BC) blocks shown, corresponds to the Position/Dimension Diagram (P/D) in Figure 5-13.

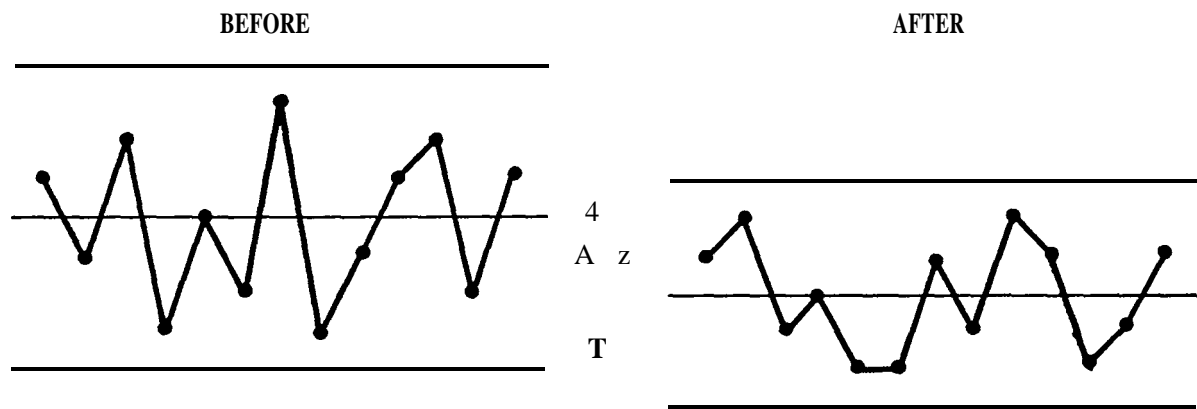

FIGURE 5-15: Breakthrough is said to have occurred when a change in work circumstances causes \bar{x} to shift and/or the upper and lower control limits to come closer together.

5.4 Process Analysis

Effective control of accuracy is dependent on proper understanding of *variation merging equations* such as those given in Figure 3-4. Too much focus on a merged variation, Z , is not worthwhile. It is more important to focus *on* each factor on the right side of each equation. If these factors are sufficiently controlled, nominal checks will suffice to confirm each merged variation. Some of these nominal checks, usually by sampling, are useful for balancing alternatives such as gas cutting vs. back-strip welding as shown in Figures 5-2 through 5-4.

The alteration of a design dimension to control the amount and type of rework is a form of process analysis.

Based on the variation merging equations, additional types of process analyses are possible. The impact of altering assembly sequences can be evaluated in terms of rework types at succeeding work stages.²

Since these equations indicate the contribution of individual work process variability to final or-merged variability, prime candidates for process or methods improvement are analytically pinpointed. Such methods of analysis, to reduce process variability, can involve consideration of new tools, additional training, modified work environment, etc. Employing statistical techniques, effective shipbuilders witnessed the advent of spontaneous quality circles which they subsequently trained to apply formal analysis techniques. Such efforts lead to constant breakthroughs in productivity improvement, i.e., for a work process, change in the mean variation and/or shift in the standard deviation of variation as shown in Figure 5-15.

²For a detailed example of this type of analysis see "Accuracy Control Variation-Merging Equations: A Case Study of Their Application in U.S. Shipyards: Richard Lee Storch, The Journal of Ship Production, The Society of Naval Architects and Marine Engineers, May 1985 (ISSN 87564417).

6.0 SUGGESTIONS

6.1 Design

The hull-block construction method developed naturally following the introduction of welding many years ago. Some shipbuilders changed their organization of structural drawings to suit. Appropriate drawing titles evolved such as: *block erection plan, block assembly plan, sub-block assembly plan and part-cutting plan*. These are more than traditional detail design drawings because they associate classifications of parts and assemblies with specific manufacturing levels in production. They are, literally, work-instructions.

Design and material definition should be truly regarded as aspects of planning and drawings should be further developed as virtually complete work instructions including A/C work. When A/C requirements, particularly vital points and dimensions and excess allowances, are included:

- checking and recording are clearly delineated as work just as much as marking, cutting, fitting, etc.
- excesses to compensate for shrinkages are adequately considered and are consistently applied, and
- the potential for human error is reduced; loft, fabrication and-assembly workers no longer have to refer to separately prepared A/C requirements or depend upon recollections.

In addition to the need to include A/C information in design outputs, designers should also be required to respond to A/C analyses. A/C feedback includes variation reports, design and process improvement recommendations and updates to the A/C data base. Designers should be collateral responsibilities to participate in A/C analyses particularly as they apply to evaluating the affect of design alternatives on productivity. Further, designers should be alert to promptly update detail design standards commensurate with a shipyard's changing accuracy capabilities.

6.2 Mold Loft

Strictly speaking, loft processes should be subject to the same A/C scrutiny as marking and cutting in a part fabrication shop. However, mold-loft process variations are too small to significantly impact on merged variation during part fabrication. But, loft errors (mistakes, omissions, etc.) are of concern because they disrupt the A/C cycle.

Errors cannot be treated with classical A/C theory, i.e., they do not enter into variation merging equations. Therefore, for A/C purposes written procedures should be developed in order to address:

- classifications of errors, and
- methods for checking, recording and analyzing (the statistical principles described in Appendix B could be used).

Further, qualified people should be assigned as specialists to do the checking. Loft defect lists and graphic representations of frequency of occurrence, as shown in Figure 6-1, are control mechanisms used by A/C engineers.

Each mold loft should be regarded as a nucleus for A/C activities because it generates most of what is used both for achieving and maintaining a specified degree of accuracy. Loft processes for producing N/C data, templates and other information formats should include essential A/C requirements such as:

- locations of vital points,
- calculated vital dimensions,
- calculated special dimensions which facilitate assembly and checking work,
- reference lines and check points,
- adequate marks for lay out marking (while most are sufficient for snapping a chalk line, there is difficulty in identifying which marks associate with each other).
- excess already incorporated (e.g., when workers do not have to separately mark an excess allowance, A/C is enhanced).
- more sufficient *bridging instructions* to minimize warpage and shrinkage during gas cutting.

6.3 Production Control

If just the terms *part fabrication, sub-block assembly and block assembly are coded in a marking system* for interim products, a relatively modern innovation to some it is difficult to relate an explosion of vital points to an explosion of a hull into interim products. Further classifications of such products should be included in a marking system so that each interim product has a unique identity, e.g., by zone. In other words, a fully developed product-oriented work breakdown structure is essential for effective A/C planning, executing and evaluating.

Via product orientation, designers can respond more readily to production control requirements for work instructions. The latter are more than just detail drawings because they define interim products and specific sequences for their manufacture. With information so organized designers can more readily respond to A/C requirements to include, for example, tolerance limits and vital points in work instructions. Providing such information in work instructions, because they are the most universality employed documents, facilitates mutual understanding of A/C requirements and more efficient execution by loft, fabrication and assembly workers as well as by members of the A/C group.

ACW 300	PARTIES CONCERNED		DESIGN	MOLD LOFT	FIELD SHOP	A
	DEFECT TYPE	SHIP NO. DETAIL				
E.P.M. (INTERNAL STRUCTURE)	FORM	JOINT LINE				
		BRACKET				
	FITTING	POSITION				
		SLANT				
		NO SLANT MARK				
	SCALLOP	WRONG MOLDL				
		INDICATION				
		MARKING				
	BEVELING	CUTTING				
		INDICATION				
		JUNCTION				
	HOLE	CUTTING				
		POSITION				
		SIZE				
	SLOT	CUT				
		SYMBOL				
	BASE LINE	WRONG DIRECTION				
		NO MARK				
	Q' TY	SHORT				
	NO MARK OF PARTS					

ACW 300	PARTIES CONCERNED		DESIGN	MOLD LOFT	FIELD SHOP	A
	DEFECT TYPE	SHIP NO. DETAIL				
SIZE LIST (SHAPE, FC, FB)	SIZE	INDICATION				
		LONGER				
		SHORTOR				
	BEVELING	INDICATION				
		CUTTING				
		NO TAPER				
	SCALLOP & DRAINHOLE	MARK				
		INDICATION				
	SERRATION	CUTTING				
	SNIP	INDICATION				
		CUT				
	SUB TOTAL					
TOTAL						

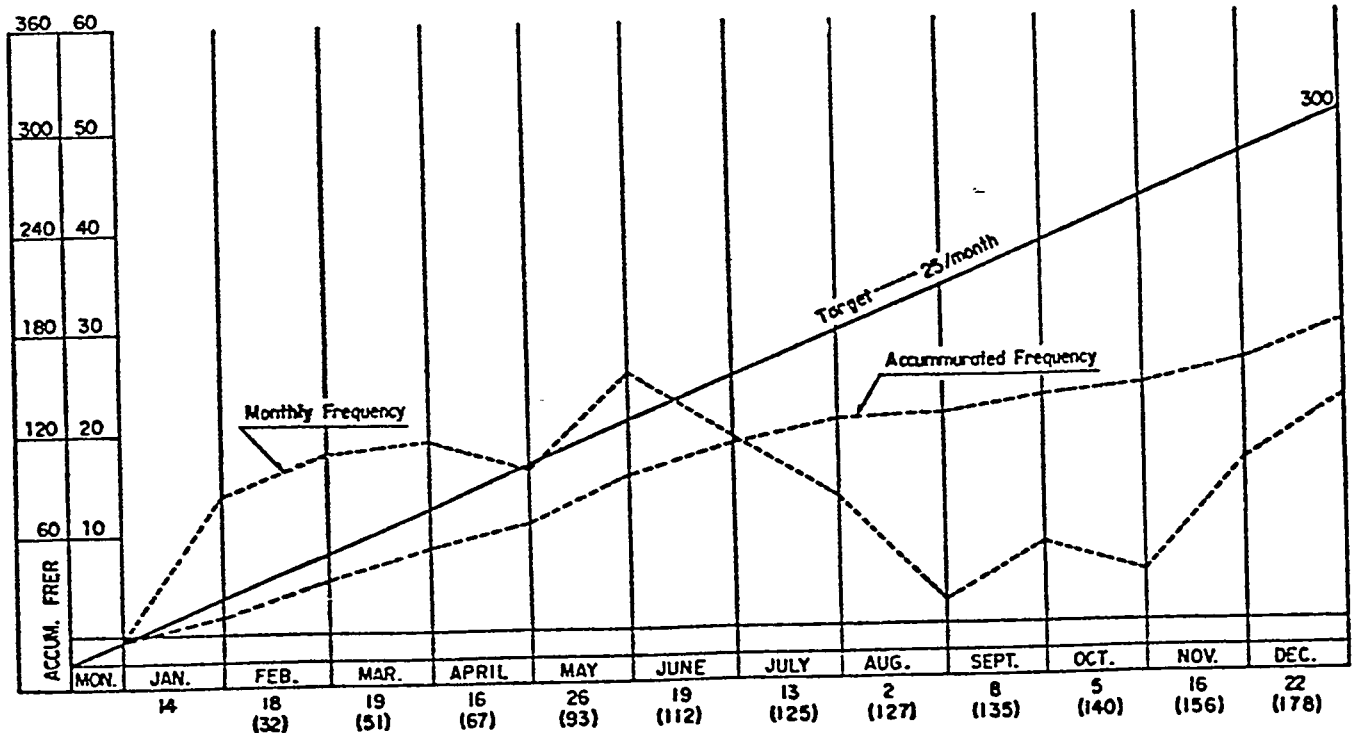

FIGURE 6-1: Defects or errors are not the same as variations. A/C engineers use mold-loft defect lists and graphic representations as aids for control of mold-loft errors.

In addition product orientation permits sufficient classification of the myriad of part and subassembly geometries in order to relate them to specific work processes. This association is critical for obtaining valid A/C data. Otherwise, work circumstances are insufficiently controlled and virtually no data sample will approximate a normal distribution. A/C as a science would not be applicable.

6.4 Fabrication

N/C gas cutting is almost universally applied by shipbuilders but there are still situations where semiautomatic cutters are useful supplements to N/C installations. More variation is probable in a semiautomatic process, therefore, A/C requirements should be different. However, there are common considerations when accuracy performances need to be enhanced:

- human engineering aspects apply, even for very advanced N/C systems,
- shrinkage allowances should be specified differently for different part classifications, e.g., parallel plate part, internal part, etc.,
- kerf tolerances should be specified,
- maintenance and accuracy checks, more complicated for an N/C machine, should be performed regularly and frequently, worn torch-tips should be replaced and others cleaned,
- as heat deformation problems have not been totally solved, even where shipbuilding technology is most advanced, measurement data should be accumulated on the effect of different cutting sequences, bridge restraints, etc., and
- A/C engineers should be alert for cutting alternatives, e.g., lasers which can be focused, could perform with narrower kerfs, less heat input and thus less shrinkage and distortion.

6.5 Sub-block Assembly

Methods to control deformation, such as pretensioning, preheating and speeded welding sequences, should be practiced. Regarding shrinkage, consider the panel for the sub-block shown in Figure 6-2. When the large plate is gas cut, shrinkage Δ_1 , occurs because no bridges were provided across the cutouts. Additional shrinkage Δ_2 occurs when the large plate is welded to the small plate. Without a shrinkage allowance, the combined shrinkage $\Delta_1 + \Delta_2$ could necessitate rework, i.e., making the cutouts deeper during block assembly.

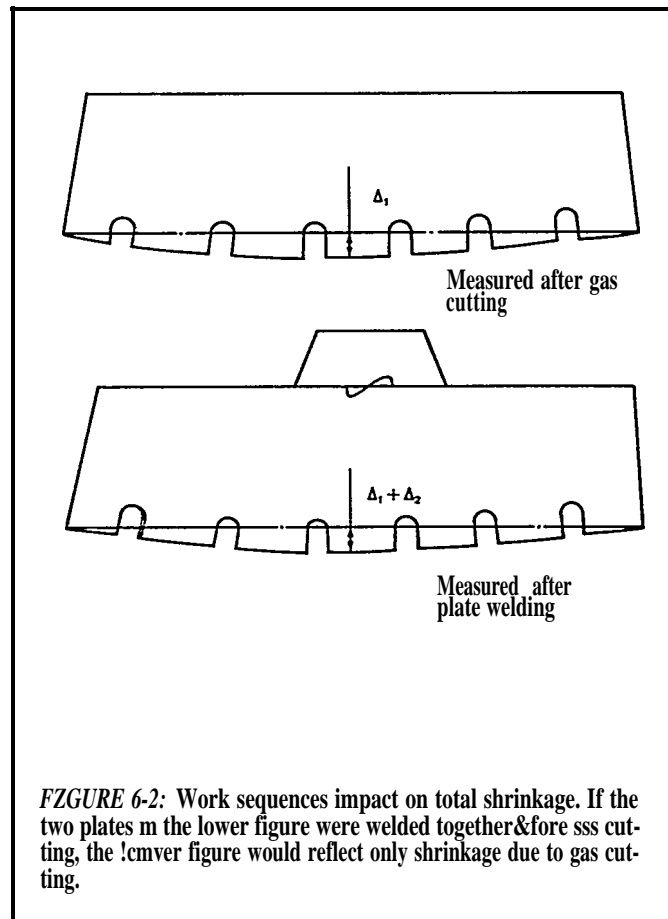

FIGURE 6-2: Work sequences impact on total shrinkage. If the two plates in the lower figure were welded together before gas cutting, the former figure would reflect only shrinkage due to gas cutting.

In order to overcome such shrinkage:

- the two plates should be welded before gas cutting,
- bridges should be used across cutouts,
- all stiffeners and face plates should be fitted to the web before welding commences, and
- welding should conform to a prescribed sequence.

Further, deformation such as caused by welding should be diminished by pretensioning and/or removed by line heating.

Fitting processes for sub-block assembly are mainly performed manually. Where A/C is ongoing, there is an indispensable close association between supervision of sub-block assembly work and the A/C engineer assigned to the sub-block assembly section (perhaps in a small shipyard assigned to the hull construction department). Because of preoccupation with variations in each work process and how they merge, the A/C engineer readily detects situations where simple jigs enhance both accuracy and productivity. More such jigs should be used.

6.6 Block Assembly

All of the preceding suggestions for sub-block assembly should also be applied in block assembly. During this stage, because it is just before erection, checking for accuracy is very critical. The checks should include alignments of platen and pin-jig foundations and means for positioning plates to form the panels upon which blocks will be assembled. Regarding curved blocks, pin-jig heights should be checked. After a curved panel is assembled, marked, checked and finish cut, the positions of its curved edges should be carefully checked. Further, simple jigs should be used to fix end positions of longitudinals and their angle of inclination.

6.7 Standardization

Standards infer conservatism. Quite the opposite is true particularly for A/C matters. A standard is simply a description of an authorized and currently practiced condition which is a baseline for comparing proposed improvements. Thus standards are means for a shipyard, as an entity, to know what it is doing and where it is going in shipbuilding technology matters. Adequate standards, in numbers and content, and sufficient specialists to modify, create and cancel standards are necessary for continuously improving productivity. Many shipbuilding problems can be solved by developing standards for:

- accuracy,
- excess and shrinkage allowances, and
- work flows and work processes.

6.8 Accuracy Standards

Because they are expressed as both standard ranges of accuracy normally encountered and tolerance limits beyond which rework is required, accuracy standards can describe a shipyard's potential for complying with tolerances specified for end products.

Just as much as accuracy standards are baselines for evaluating proposals to improve productivity, they are baselines for improving accuracy in an end product. If accuracy standards and an ongoing A/C organization which supports them are approved by a classification society, reapprovals for additional ship construction are usually unnecessary. See Appendix D.

6.9 Excess and Shrinkage Allowance Standards

Excess is an essential concept for successful application of A/C to hull construction processes. However, the amounts should be based on analyses of actual data which reflect the shipyard's experience. Excess amounts statistically derived, are based on the probability that for a high percentage no rework will be required. Thus, applying excess is an attempt to exactly compensate for normal variations caused by work processes which lead to variations in joint-gaps to be welded during erection. There must be understanding that a small percentage will require rework by gas cutting and/or back-strip welding.

Excess is generally thought of as a means for extending the edge of a plate to compensate for shrinkage. However, its use elsewhere should be specified such as for facilitating the fit of stiffeners between longitudinals; see Figure 1-4.

6.9.1 Elements of Shrinkage Allowance

- Shrinkage allowance is required to maintain the specified shape and dimensions at hull erection. The amount of shrinkage allowance for gas cutting, welding and/or line heating should be derived from data collected during shipyard operations.
- Shrinkage allowance is required for fillet welding internal members to shell plates (A). Shrinkage occurs in the direction normal to the welding line.
- Shrinkage allowance is required for removing welding-induced distortion by line heating after assembly work (B). This removes opposite-side indentations caused by fillet welding internal members. After assembly, heat is applied on the outboard side of the shell along lines which are exactly opposite the fillet welds. Shrinkage occurs in the direction normal to the heating lines.
- Shrinkage allowance is required for welding plates to form the panel on which a block is assembled (E).
- Shrinkage allowance is required for fillet welding stiffeners, e.g., flat bars and brackets to internal members such as a web plate (a).
- Shrinkage allowance is required for line heating on sub-assemblies, such as webs, to remove the indentations caused by welding (b).
- Shrinkage allowance is required for welding plates of internal members such as webs (e).
- Shrinkage allowance is required to compensate for welding and line heating other miscellaneous interim products, i.e., parts, blocks of special shape, etc.

6.9.2 Ways to Distribute Excess

There are two practical ways to predict the excess needed to offset shrinkage as described in the foregoing:

- Provide excess amounts only at edges of a block without regard for apportioning excess between block internals. Thus, the dimensions needed for layout are readily obtained from design drawings. However, the final positions of the internals will be different from specified design.
- Distribute excess proportionally taking into account shrinkage rates expected to be caused by each work process and the relative spacing of block internals from each other and panel edges. This method requires recalculating the dimensions needed for layout, but the final positions of internals will more accurately conform with design.

6.9.3 Ways to Distribute Excess vs. Assembly Sequences

Sequences for assembling a block, consisting of a panel stiffened by longitudinal ribs and webs, can be classified as “eggcrate” or “weld longitudinal to panel first”. The work sequences are different as shown in Figure 6-3. Thus, the shrinkages caused by welding are sequenced differently. This is important because restraints are different, the heat input for different welds varies and regions which have been shrunk before do not shrink the same amount, even for the same heat input, during subsequent welding. Thus, the pertinent data that shipbuilders collect should be classified to match one or more of the four assembly alternatives depicted in Figure 6-4.

6.9.4 Standards for Work Processes and Information Flow

In order to establish effective standards, the role of each fabrication shop and assembly section must be carefully reviewed for its impact on production process flow. The inputs and outputs of each should be clearly defined and consistent with a single A/C system. In other words, everything on the right side of the variation merging equation must be compatible in order to obtain the best productivity for the entire hull construction process.

There cannot be dependence on just parochial knowledge. Written work processes which regard each other are essential for achieving specified accuracies and uniform flows of work and information. Standard processes also make it easier to change jobs and are a great aid for training. When a process standard is revised to incorporate an improvement, related others should be reviewed and/or revised as necessary.

The following guidance applies to standards which should be established:

- *standard practices for*
 - working instructions
 - lofting
 - fabrication (marking, gas cutting, bending, line heating)
 - sub-block assembly
 - block assembly
 - shipwright work
 - welding
- *A/C contents of standards*
 - check points
 - dimensions to be checked
 - checking methods
 - tolerance limits
 - checking procedures for jigs and machinery
 - feedback and remedial measures
- *examples of standards for block assembly*

for flat block

- plate arrangement (positioning, match mark)
- welding (misalignment, gap)
- panel marking (diagonal length, width, straightness)
- holes

for a curved block

- supporting jig (normality, height)
- plate arrangement (jig position)
- datum line for joining
- block marking (four edges, diagonals)
- holes

“EGG-CRATE” WORK SEQUENCE	“WELD LONGITUDINAL TO PANEL FIRST” WORK SEQUENCE
<ol style="list-style-type: none"> 1. Panel Assembly (E) 2. Panel Marking 3. Eggcrate Assembly (a,b,e) 4. Eggcrate to Panel Welding (A) 5. Line Heating (B) if necessary 	<ol style="list-style-type: none"> 1. Panel Assembly (E) 2. Panel Marking 3. Longitudinal to Panel Welding (A) 4. Other-internals Welding (A,a,b,e) 5. Line Heating (B) if necessary

FIGURE 6-3: When assembly sequences are different, the sequences of shrinkage and the amounts of shrinkage differ. Fitting problems will occur if different shrinkages are not anticipated. The parenthesized letters designate pertinent descriptions in Part 6.9.1.

for fitting

- elimination of welding-bead rise where internals meet panel joints
- gas cutting (notch, roughness, check line)
- end of web position
- end of frame position
- angle of internals relative to a panel
- collar-plate fitting
- misalignment and gap where internals join each other

grinding

- bead removal for rework
- bead removal to free temporary fitting

line heating

- block interface edges
- specified temperatures
- specified locations
- fairing

TEST DESCRIPTION (LINE THICKNESSES Imm)		STANDARD DEVIATION
a	MARKING LINES a < 1,000 mm a ≥ 1,010 mm	s = 0.5 mm s = 0.6 mm
a b	REFERENCE LINE a < 1,000 mm a ≥ 1,000 mm	s = 0.4 mm S = 0.4 mm
	 REFERENCE LINE a < 1,000 mm	s = 0.4 mm

FIGURE 6-5: Tests of measurement methods by one firm indicated that even folding rule do not cause significant variations. However, each shipyard should perform similar tests.

EXCESS DISTRIBUTION	ASSEMBLY SEQUENCE
Only At Panel Edges	Egg-crate
	Weld Longitudinals To Panel First
Proportionally Throughout	Egg-crate
	Weld Longitudinals To Panel First

FIGURE 6-4: There are two possible assembly sequences for each of two methods for excess distribution.

6.10 Measuring

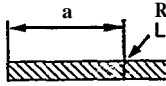
Some variations are inevitable due to differences in:

- measuring methods,
- environments,
- work circumstances,
- reading judgments, etc.

One shipbuilding firm conducted tests of measurements obtained with folding rules that are popular among shipbuilders. Of all devices folding rules were suspected of causing the most measurement variation. The results, shown in Figure 6-5, indicate that even their use does not significantly contribute to merged variation. However, each shipyard should verify its own measuring capabilities.

6.11 Photographs of A/C Practices

Figures 6-6 through 6-15 illustrate A/C ideas already employed by shipbuilders to control accuracy and simultaneously enhance productivity.



A.

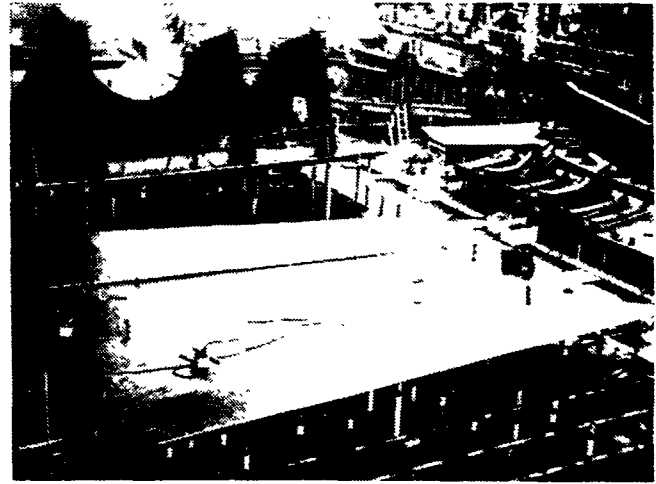

B.



C.

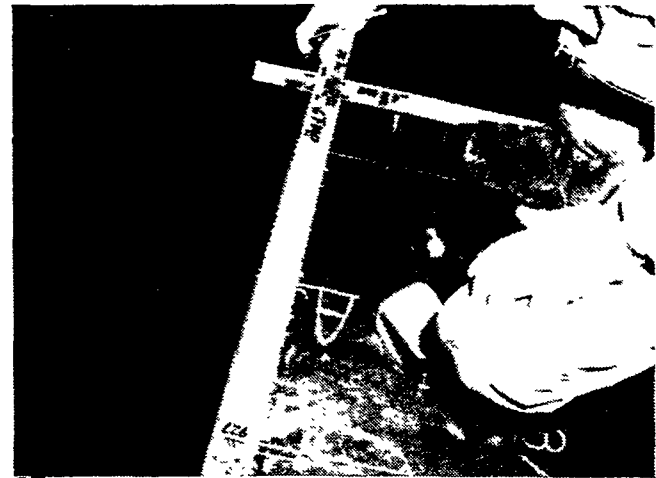

D.

FIGURE 6-6: A. Layout tapes are prepared by loftsmen on a long table having a ruler fixed to its surface. A loftsmen, reading a work instruction drawing, marks only locations and legends of interest. As shown in the background, identity of a specific application is on the reverse side of each tape. The tapes are of special-tempered steel so that they easily coil and when released readily lay flat. A light coating both prevents rusting and provides a good contrast for marks.

B. Tapes are for layout of overall dimensions, diagonals to confirm rectangularity, and positions of block internals after plates are welded together to form a panel as shown.

C. Even where N/C capabilities exist, tapes are also used for the layout of certain parts, e.g., parts for non-parallel midbody of a custom-designed ship.

D. Part fabrication and assembly workers simply transfer marks from tapes to plate and panel surfaces. They are not burdened with the need to interpret blueprints nor are they encumbered with irrelevant dimensions which appear on rulers.

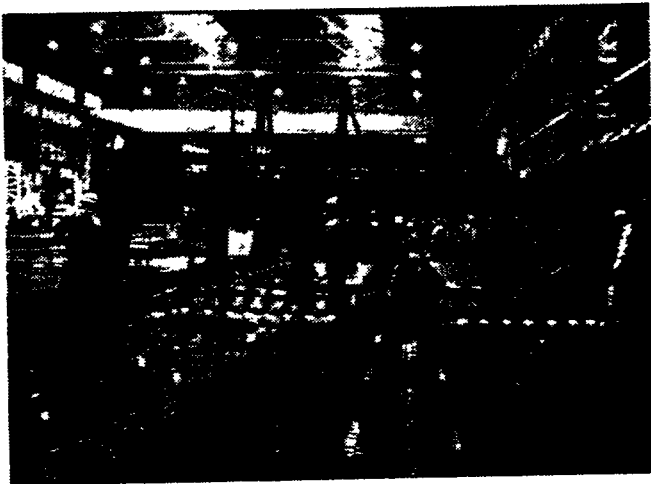

A.

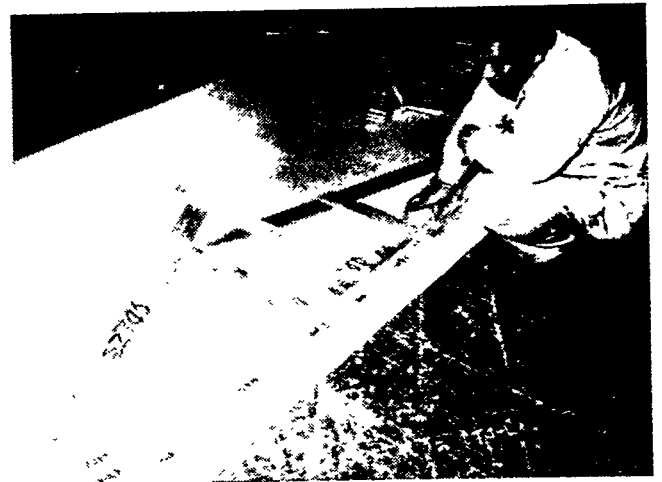

B.

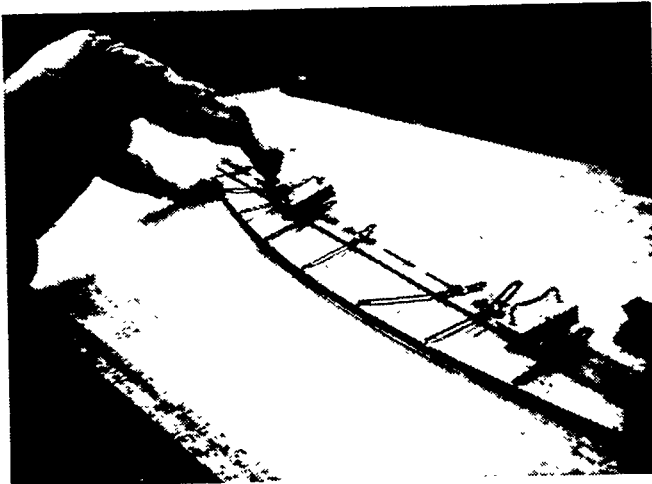

C.

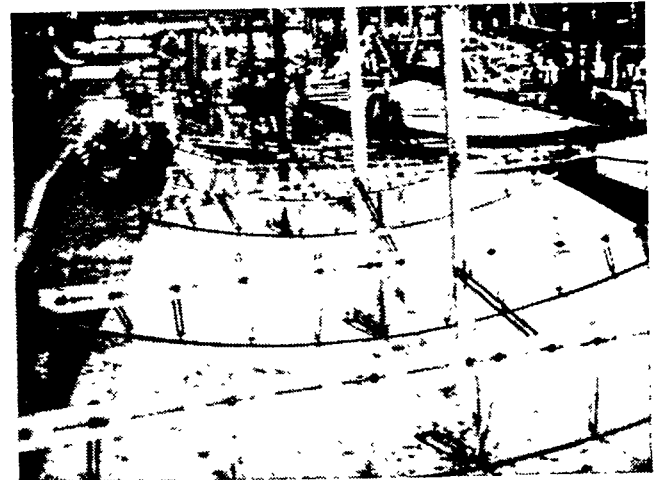

D.

FIGURE 6-7: A. Semi-automatic (shown) and manual line heating methods are applied as controlled work processes for forming curved plates. Similar techniques are also used after rolling or bending to refine the curvature achieved. Line heating is not limited by furnace size, as for forming by a blacksmith, nor limited by press and roller capacities. Thus, line heating is being applied to increasingly wider and longer plates as a means for reducing the lineal footage of welding required and associated shrinkage which complicates A/C.

B. Loftsmen prepare for each part, a family of sight-line templates on a single Mylar sheet and thereafter, as one option, reproduce the templates in wood. Each template features a vertical member having one side designated as a sight face and on which appears a sight-line mark, "<". Match marks are provided on the bottom of each template to coincide with plate edges. A station number and angle of inclination relative to the plate surface, when curved, are noted on each template.

C. Some part-fabrication shops directly employ a "Mylar" for setting a family of adjustable sight-line templates.

D. Transverse curvature is checked by measuring the distances between each template's curved edge and the plate surface between applications of line heating. Correct twist is obtained when the sight faces of all templates are in the same plane. Proper longitudinal curvature is achieved when the sight-line marks all coincide with a taut string.

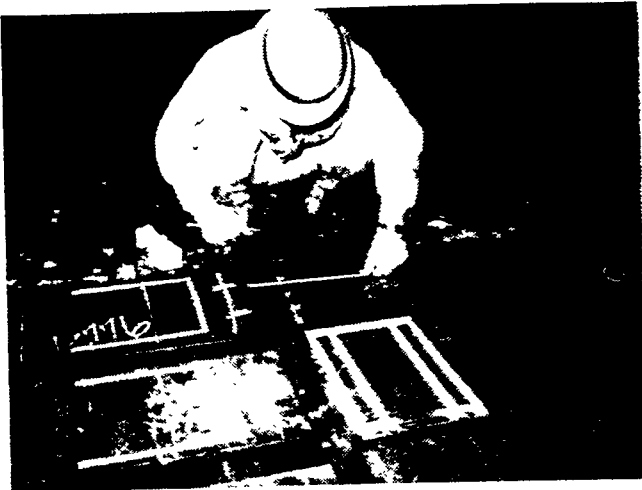

A.

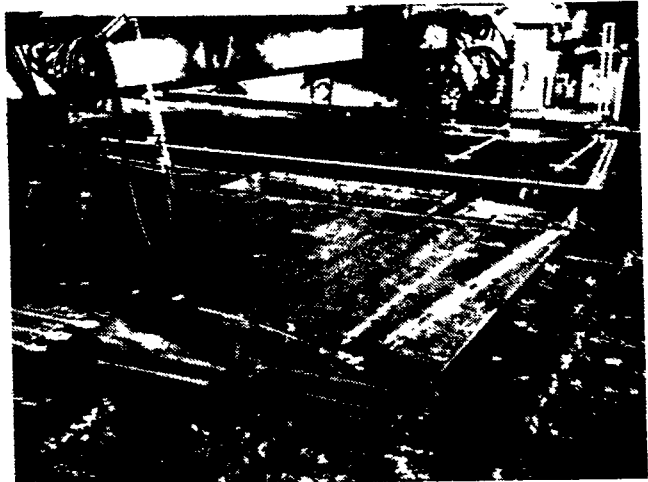

B.



C.

FIGURE 6-8: A/C engineers establish requirements for reference lines 50 millimeters back from cutting lines. Samples of such measurements are recorded in order to determine their standard deviations as the accuracy of reference lines contribute to merged variation.

A. A reference line is self-checked to verify that it is 50 millimeters from the marked cutting-line. The jig in the foreground was developed specifically to enhance accuracy for marking reference lines on flat-bar ends.

B. Reference lines are also included in N/C marking instructions so they appear parallel to edges which will be cut and that contribute to merged variation. Measurements of the distance between a cut line and its reference line are used to monitor accuracy of the machine.

C. After cutting, measurements between a cut edge and its reference line are made and recorded (not shown). Since reference lines exist for such purposes, they are used as shown for setting an adjustable mono-rail for semi-automatic cutting a long "slow" curve.

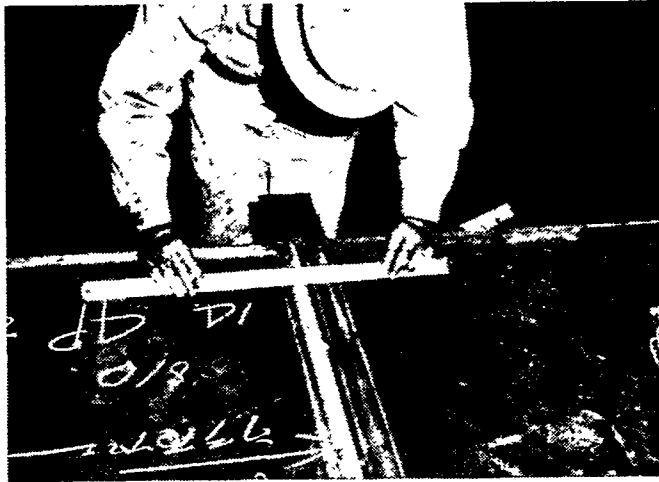

A.

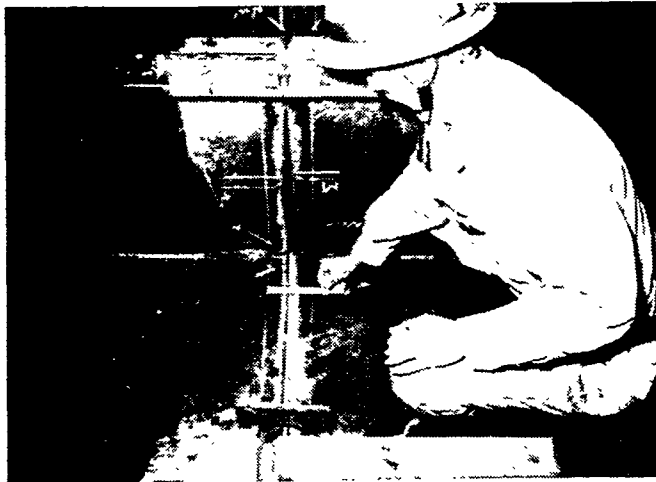

B.



C.

FIGURE 6-9: During sub-block assembly, block assembly and hull erection, measurements of the distances between reference lines, and from reference lines to parts, are obtained and recorded just before and after welding. Analyses of such data advises A/C engineers of fitting accuracies and shrinkages actually being experienced.

A. Measuring between reference lines after welding plates to create a panel during block assembly.

B. An A/C engineer demonstrates measuring between reference lines just before an erection-joint gap is to be welded. The scale being used is sized and graduated just for this purpose and is attached by a key ring to a graduated, thin wedge used to measure gap widths.

C. Demonstrating how to measure gap width in a bottom longitudinal.

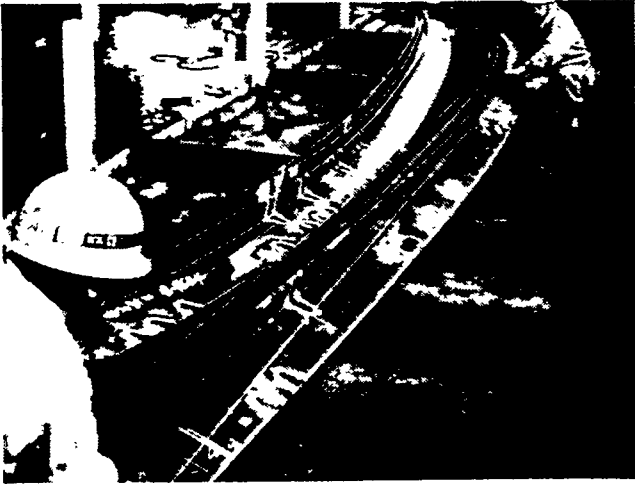

A.

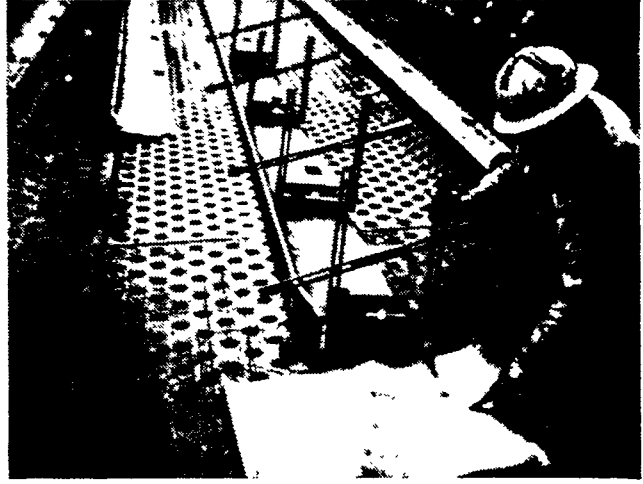

B.



C.

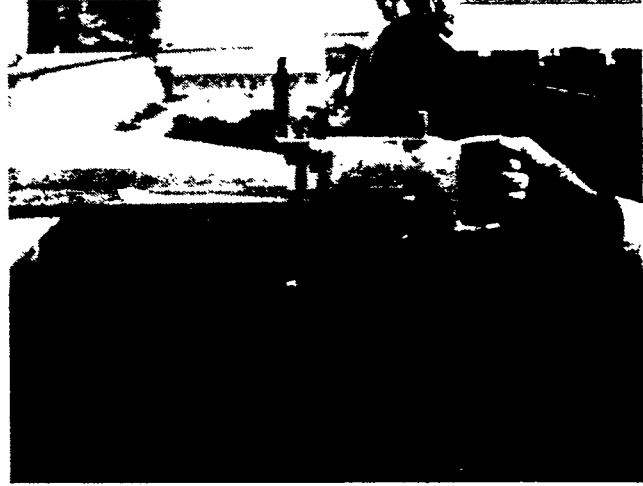

D.

FIGURE 6-10: Loftsmen calculate vital dimensions and provide for vital points, reference lines and check points as specified by A/C engineers and incorporated in work instructions.

A. Inverse curves which were marked on straight members become straight lines when specified bending is achieved. After self checks, part-fabrication shop supervisors measure and record deviations using a taut string as a reference.

B. For twisting a longitudinal that is already curved, loftsmen prepare a family of sight-line templates on a single Mylar sheet. This is used by part-fabrication worker for adjusting special templates to be set at specific stations on the longitudinal. A white sight-line mark appears on the adjustable bar of each template. Twisting is performed by line heating until all sight-line marks match a taut string. Subsequent measuring to establish the accuracy being achieved for combined bending and twisting employs the same sight-line method.

C. As shown in the upper left-hand corner, perpendicular bisectors are used to define a reference point or points needed to define a reference line. In order to insure that such points are not lost during surface preparation and coating, the bisecting lines are defined by centerpunch marks on either side of, and about 25 millimeters from, their intersections.

D. A simple back-side marking tool is used for accurately transferring a reference point from one side of a surface to the other side.

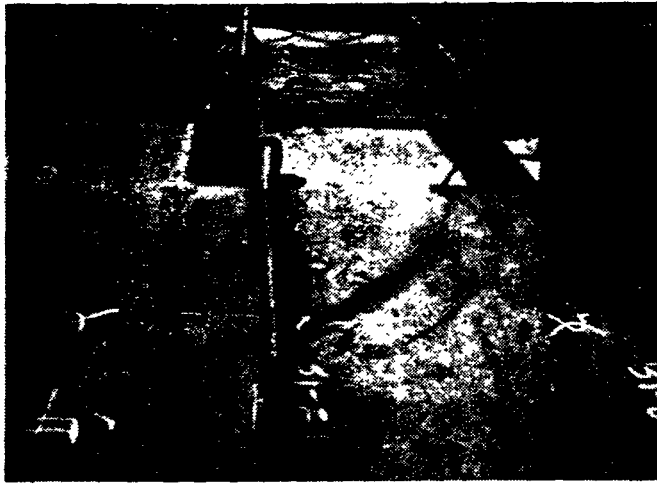

A.

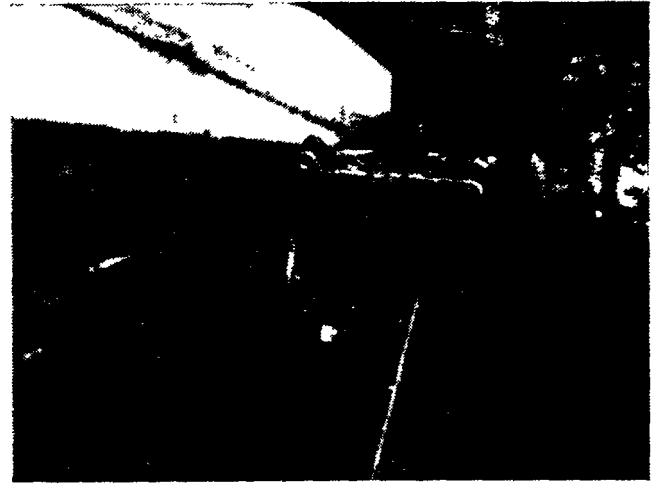

B.



C.

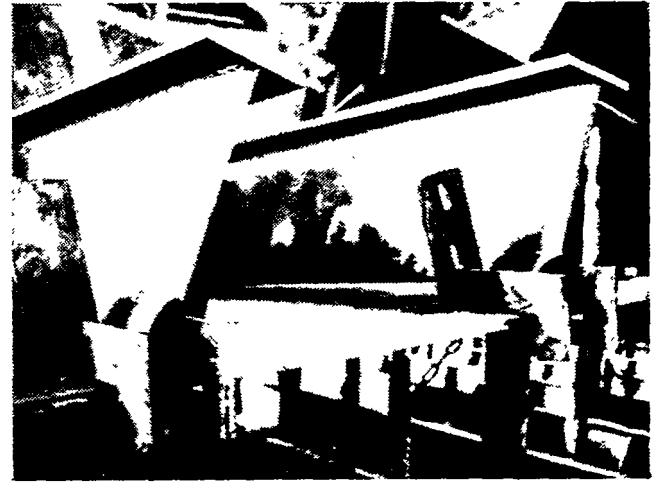

D.

FIGURE 6-11: Prudent A/C engineers assigned within a hdl construction department maintain good rapport with supervisors and their workers. When variation merging equations identify a particular work process which needs to be improved such rapport leads to effective innovations; e.g., numerous simple jigs which significantly reduce ranges of variation.

A. Siple jigs support flat bars during the fitting process.

B. A jig which supports a flange during fitting to a web, is equipped with a screw for making fine adjustments.

C. Two relatively easy to make jigs align a small sub-block vertically and simultaneously fix the sub-block at the prescribed distance from the panel edge.

D. Jigs are used to fit longitudinal at prescribed angles during curved-block assembly. The jigs are designed so that they are suitable for use on both forward or aft panel edges, and also on both port and starboard blocks.



A.

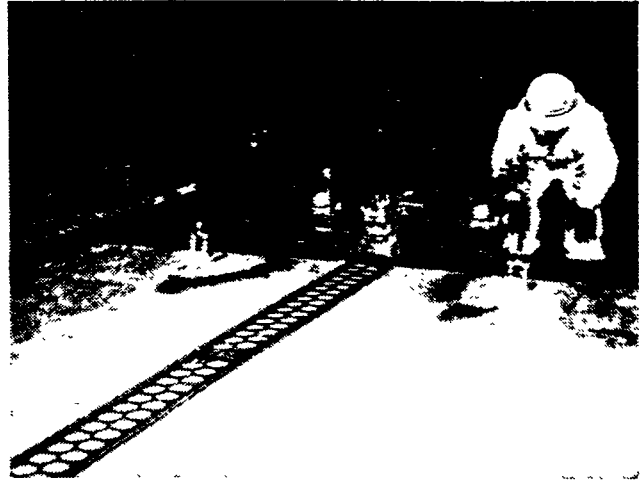

B.

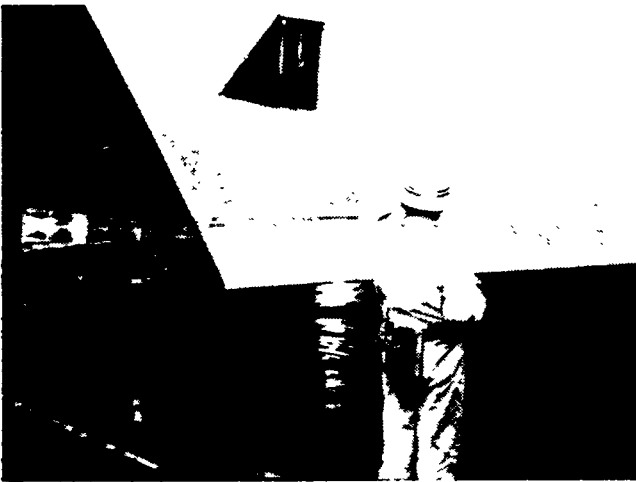

C.



D.

FIGURE 6-12: Among the variety of matters that A/C engineers address are:

- A. Gas cutting techniques to achieve very sharply defined finished edges.
- B. Line heating techniques for removing distortion from sub-blocks.
- C. Line heating techniques for removing distortion from blocks.
- D. Prestressing before fillet welding to compensate for expected distortion.

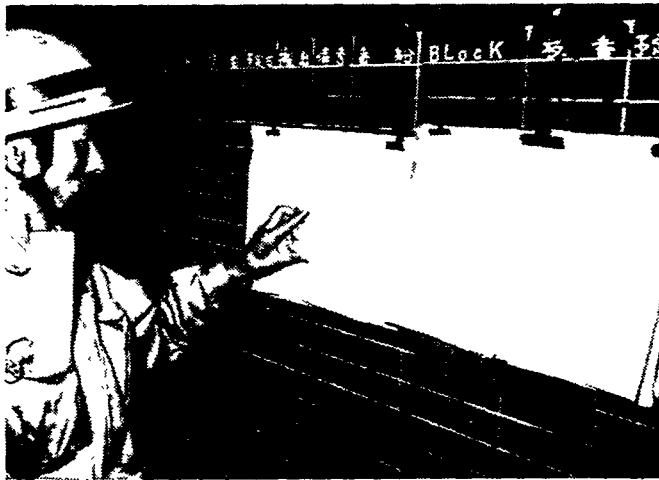

A.

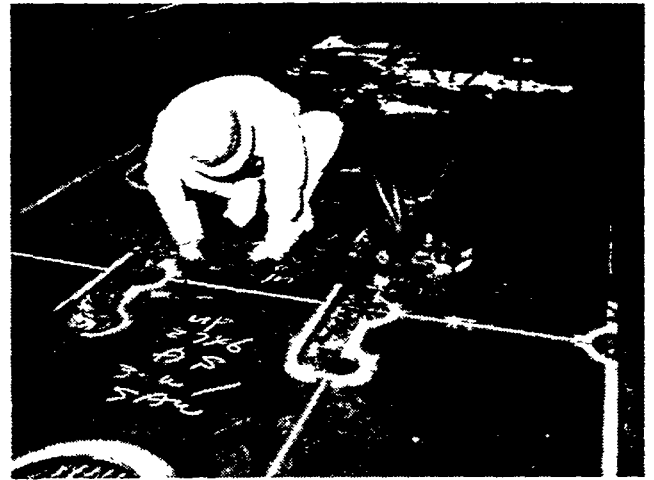

B.

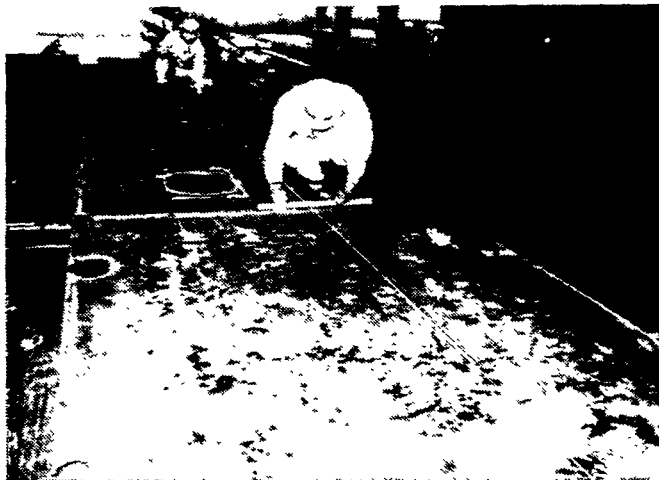

C.

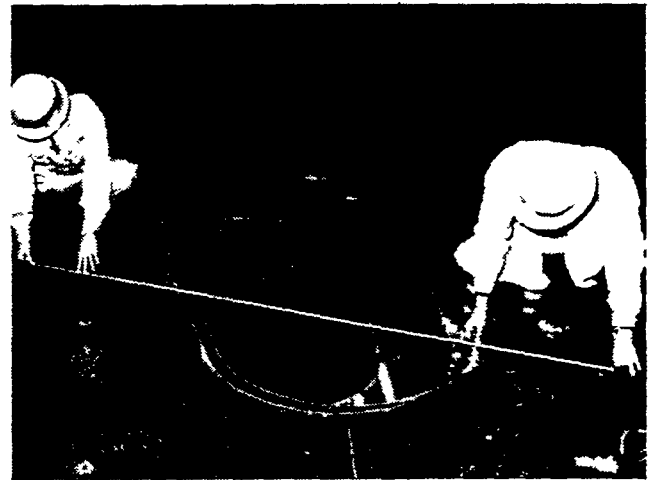

D.

FIGURE 6-13: Members of the A/C group are involved in many activities.

- A. A group member checks the \bar{x} -R control chart which is posted at the work station where parallel edge parts are cut. Work schedules are posted alongside.
- B. A/C engineers make rules for how parts are to be designed, nested and/or bridged. As shown, double-bottom floor panels are nested with top and bottom edges contiguous and so that cutouts match. The parts are not cut apart by the N/C machine as concentrated heat in the vicinity would cause unacceptable shrinkage of each cutout's length. The intact surrounding material minimizes such shrinkage. The panels, as shown, are separated later by semi-automatic cutting.
- C. A/C engineers specify the check points for using a line marked for setting a longitudinal as a reference line in order to measure deformation caused by gas cutting.
- D. They also specify how to use buttock lines as reference lines to check a transverse web of an upper wing tank for deformation caused by gas cutting.

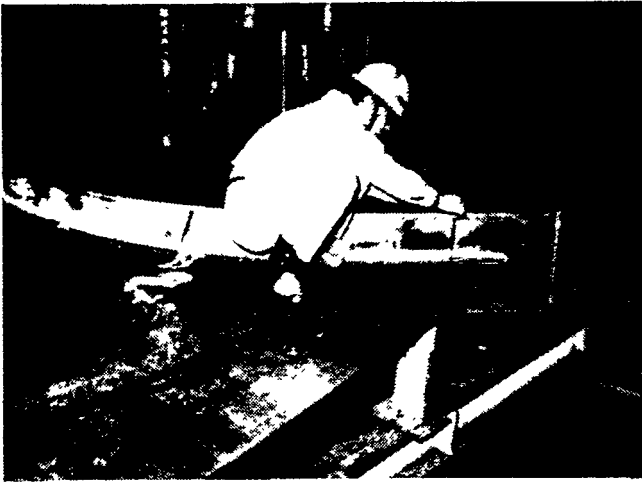

A

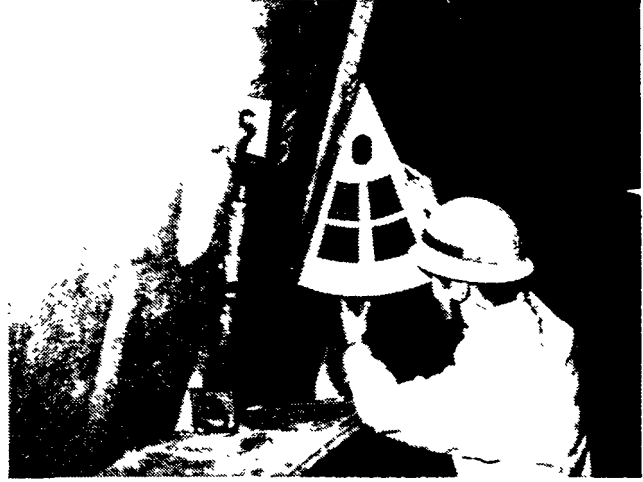

B



C



D

FIGURE 614: Typically A/C engineers establish standard procedures for:

- A. Checking the face-plate position on a web.
- B. Using a protractor and plumb bob form measuring the fitting angle of an internal member of a curved block.
- C. Checking a bracket for fitting angle, match marks, etc.
- D. Checking a finished edge for an erection butt-joint.



A



B

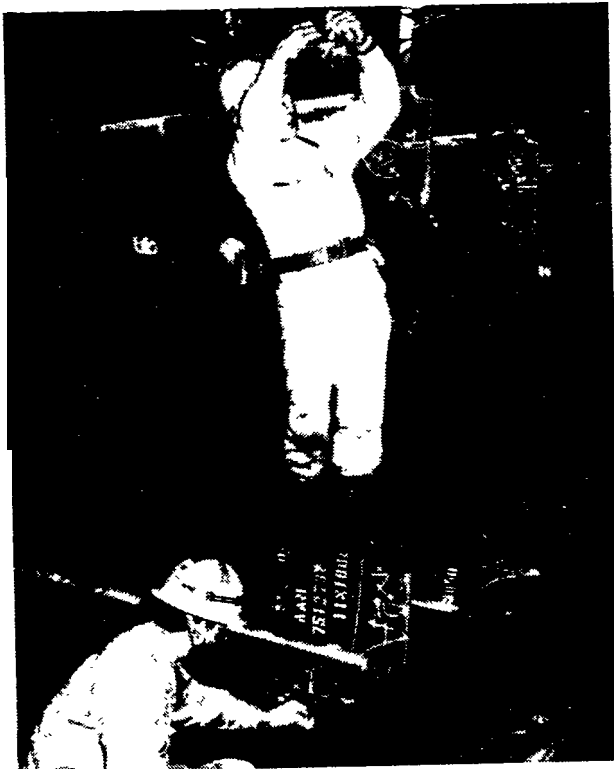

C



D

FIGURE 6-15: Specific A/C procedure apply to: A. Checking a measurement between panel and bracket edges in a sub-block.
B. Checking a measurement between the edges of a panel and internal structure in a block.
C. Checking alignment of a tank-top panel relative to a bottom-shell panel in a block.
D. Monitoring bottom alignment between keel laying and launching. The distance measured is that from the bottom shell to a reference line marked on the vertical angle-iron which is fixed to the dock floor.

APPENDIX A

PLANNING VITAL POINTS FOR A BULK CARRIER

I. Identifying Vital Points

A. Basic

Vital points are necessary for achieving accuracy specified for an end product. Thus, identifying vital points starts with the complete hull and proceeds, as any other planning activity, to address reverse production flow, i.e., erection, block assembly, sub-block assembly and part fabrication. Also, because they impose different problems, each major division of a ship body has its own vital-point explosion.

Vital points can be classified and sub-classified as

1. At Erection Stage

- a. Hold Zone
- b. Curved Zone
- c. Stern Zone

2. At Block Assembly Stage

- a. Straight Block
- b. Curved Block
- c. Flat Panel Base
- d. Curved Panel Base

3. At Part Fabrication

B. Detail Descriptions

1. *Erection Stage*

a. Hold Zone

Usually accuracy of the hold zone impacts most on the Overall form of the hull because it contains the most blocks. For vital-point matters, the hold zone can be subdivided into:

- Tank Top Zone
- Top Side Tank Zone

The tank top zone is the base of the hold and incorporates vital points for controlling

- Center line of the ship.
- Relativity between each double bottom block.
- Level of tank top.

See Attachment 1.

The top side tank zone fixes the actual width and add depth of the hull and contains vital points for controlling:

- Straightness of the base line.
- Width of the ship at main deck.
- Height of the ship at main deck.
- Level of main deck.

Details are shown in Attachment 2.

The vital points for setting each block on the ways is derived from the foregoing and noted for shipwright guidance as shown in Attachment 3.

b. Curved Zone

Vital points in the curved zone are dependent on the hold zone because the block erection sequence usually starts in the curved zone.

In order to set a curved block, fixing suitable points is necessary. For example:

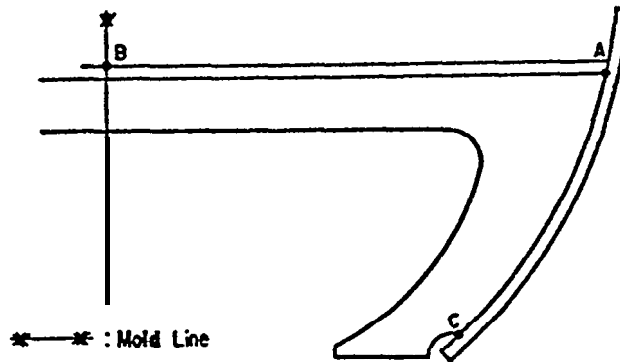

Point A: For setting the width.

Point B: For keeping straightness.

Point C: For setting the height, and checking the lower width.

Note 1: Loftsmen must prepare dimension L to locate A' on the shell:

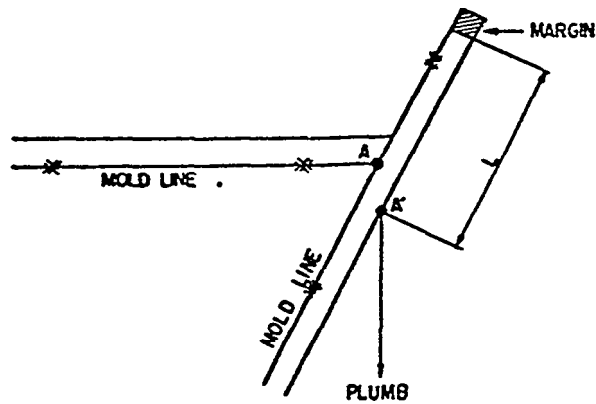

Note 2: To locate point C, Loftsmen must provide dimensions H and B.

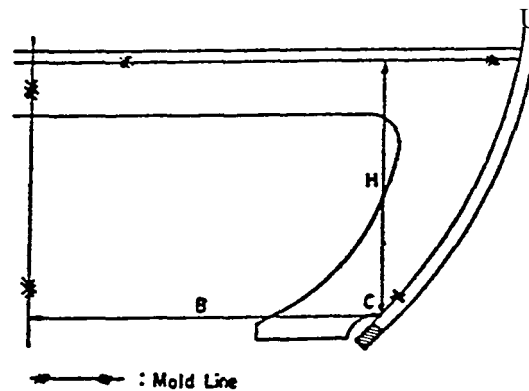

c. Stern Zone

Accuracy of the stem zone influences a ship's performance significantly. Accuracy of the shaft line involves:

- Accuracy of center of stem tube,
 - Centering.
 - Height.
- Relationship between center of stem tube and the shaft line projected to the win engine seat

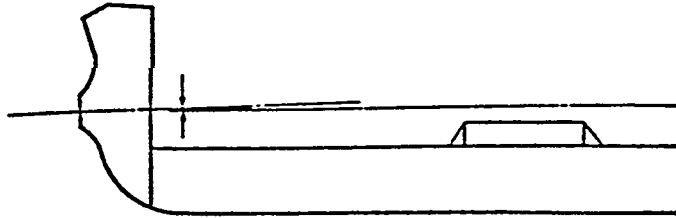

Notice: Keeping this relationship precise is especially hard because of movement of the stem block during welding. Thus, fixing vital points and maintaining their positions requires the greatest possible care.

Usually the relationship between shaft and rudder centers are fixed in one block during block assembly. However, it is still difficult to align both of them with sufficient accuracy in a building berth. The sequence for welding the plate joints located forward of the after peak-tank bulkhead is critical.

2. Block Assembly & Stage

a. Straight Block

Straight blocks are located in the hold zone, there are several typical types defined by their locations. In order to define their vital points two questions should be asked:

- Which will be the most important points for hull erection?
- Which will be the most necessary points for block assembly?

A sample of a typical check sheet is in Attachment 4.

b. *Curved* Block

Flat-panel base, curved blocks are assembled on a platen in accordance with a sequence which is partly dependent upon internal structure.

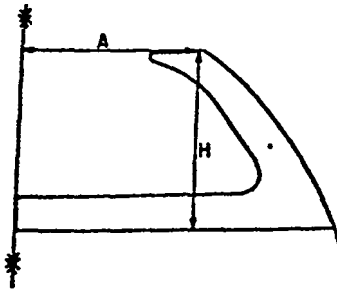

As shown the curved shell plates are set on block internals. Therefore, vital points are set to maintain vital dimensions such as A and H. The shell plate edge alignment with internal structure is also vital. See Attachment 5.

Curved-panel base, curved blocks are assembled on a pin jig. The procedure is to first join already formed plates to create a curved panel, layout the internal arrangement, and thereafter to fit and weld internals. Typical vital points and dimensions and an applicable checking procedure are described in Attachment 6.

3. *Part Fabrication Stage*

As establishing vital points in all of the many parts is impractical, parts which could cause consequential block inaccuracies are first identified. These typically are parts for:

- bottom girders
- bottom side floors
- hopper side tank floors
- hold frames

Vital point details and check sheets are provided in Attachment 7.

Appendix A, Attachment 1

VITAL POINTS FOR ACCURACY
AT ERECTION STAGE

In order to check and maintain accuracy of the tank top zone during the erection stage, three methods are necessary:

- *Center Line Check* of shift of each block in tank-top section.
- *Relativity Check* of center double bottom, center side double bottom, and bilge blocks in every hold and over the full tank-top length.
- *Level Check* of each block both on the tank top and bottom.

Descriptions

Center Line Check

When: Twice, once before fitting and once after welding.

Who: Worker and A/C engineer before fitting.
A/C engineer after welding.

Where: At the front of each block on tank top.

How: By transit (allowance max. 1/8").

Relativity Check

When: Every block before fitting and once after welding an entire hold length.

Who: Worker and A/C engineer before fitting and A/C engineer after welding.

Where: At the front edge of each block.

How: By transit (allowance max. 1/8" at each target).

Notice: If the relativity is larger than allowed and that amount is less than 1/4", defer correction until welding is complete for a hold length.

Level Check

When: Every block before fitting and after welding.

Who: Worker and A/C engineer before fitting and A/C engineer after welding.

Where: At points A, B, C and D at forward frame of each block on tank top.

After welding, the level of the points at the bottom must be checked:

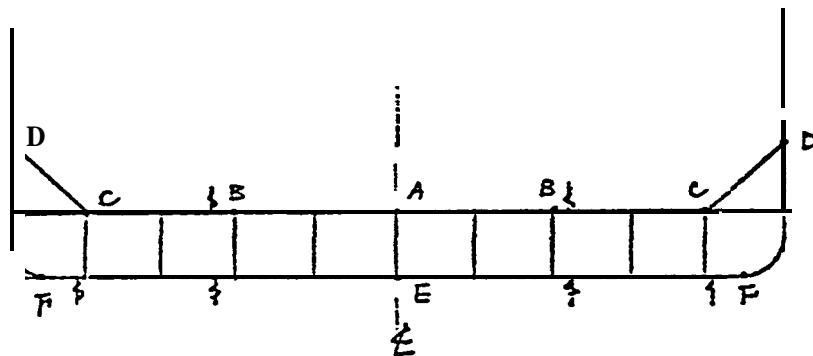

The data should be recorded and arranged in a simple style (picture, graph, chart, etc.). Further each record should contain the date, time, and temperature when the check was made. Recommended methods for recording these checks follow.

LEVEL AT EACH POINT ON T. TOP (DS 3~DS 10)

OCT
15

- A ————— = E
- C ————— = L-13 S. GIR
- D - - - - - = TOP OF BILGE/BLOCK

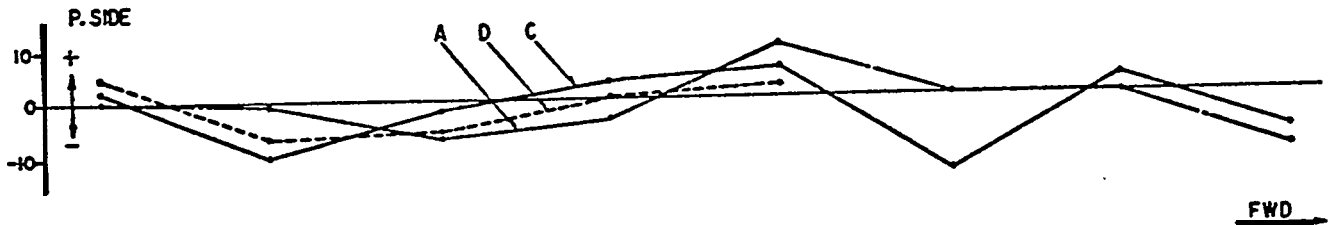

BLOCK										
DS-3	4	5	6	7	8	9	10			

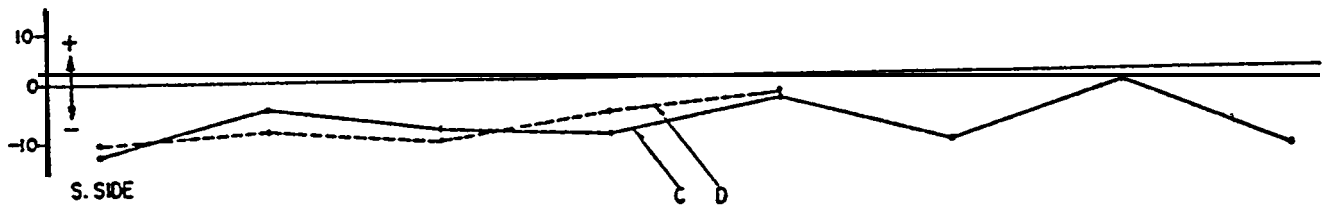

LEVEL OF CENTER LINE AT BOTTOM

BLOCK													
AP	B32	B 31	DC 1	2	3	4	5	6	7	8	DC 9	E 10	B51 B52

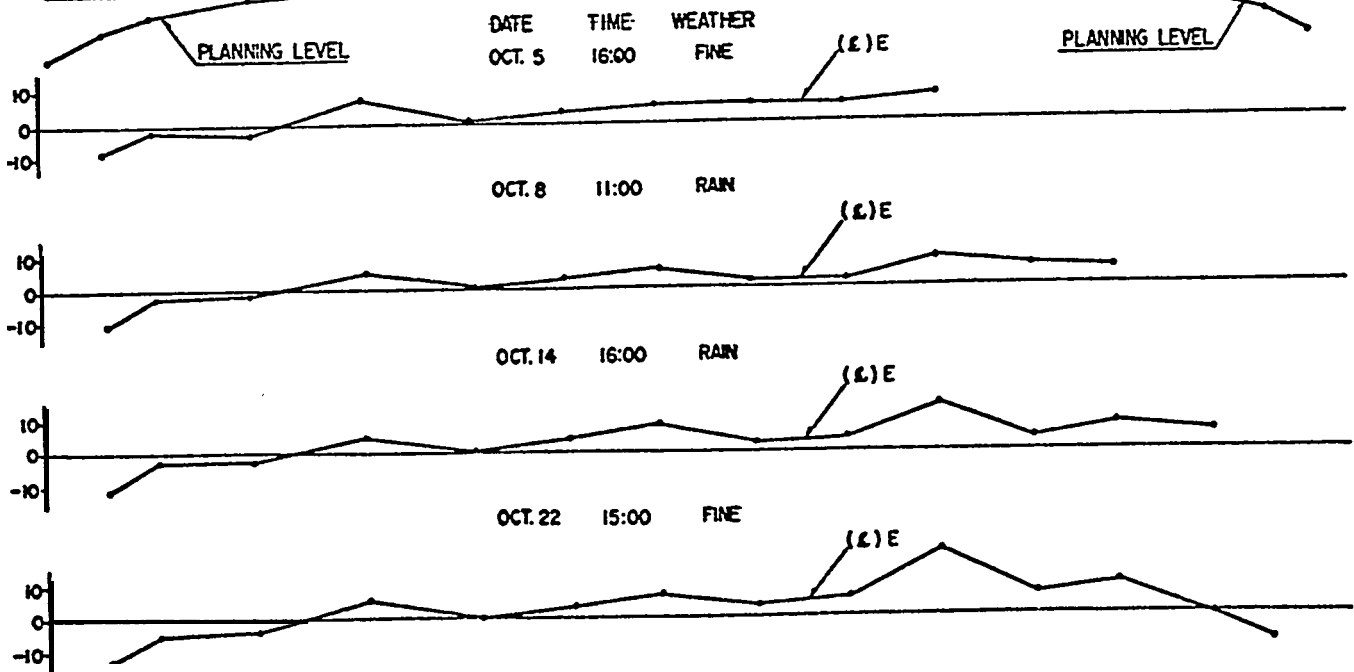

RELATIVITY AND CENTER LINE CHECK
(AT EACH HOLD LENGTH)

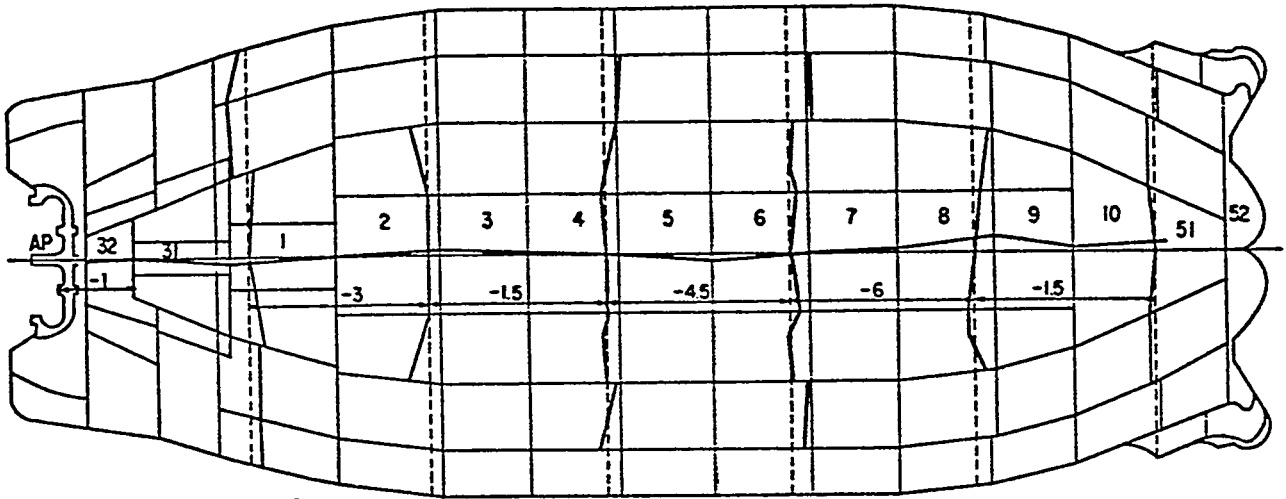

SCALE 0 10 20 30

Appendix A, Attachment 2

THE VITAL POINTS FOR ACCURACY AT ERECTION
STAGE FOR TOP SIDE TANK ZONE

In order to check and maintain accuracy of the top side tank zone, four methods are necessary

1 Straightness of the base line

- Width of the ship at main deck
- Height of the ship at main deck
- Level of main deck

Descriptions

1. *Straightness of the Base Line*

When: Twice, once before welding and once after welding at each erection joint-

Who: Worker and WC engineer before welding.

A/C engineer after welding.

Where: At the base line (see the figure at the end of this Attachment).

Notice: The base line must be marked on slabs before erection.

How: By transit.

2. *Width of the Ship at Main Deck*

Where: Twice, before and after welding.

Who: Worker and A/C engineer before welding.

A/C engineer after welding.

Where: At the base line of the front part of block (see the figure at the end of this Attachment).

How: By measuring.

3. *Height of the Ship at Main Deck*

When: Twice, before and after welding.

Who: Worker and A/C engineer before welding.

A/C engineer after welding.

Where: At the point supported by the pillar (see the figure at the end of this Attachment).

How: By measuring.

4. *Level of Main Deck*

When: Twice, before and after welding.

Who: Worker and A/C engineer before welding.

A/C engineer after welding.

Where: At least 6 points as follows:

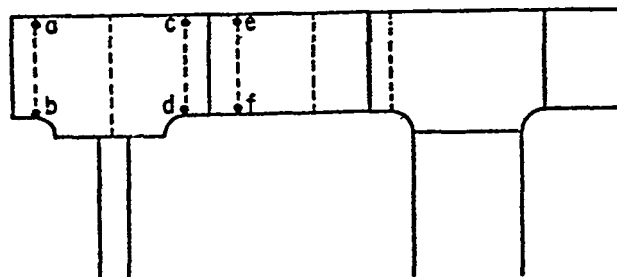

Notice: Points a & b at forward end.
 Points c & d at aft end.
 Points e & f at forward part of preceding block.
 How: By transit.

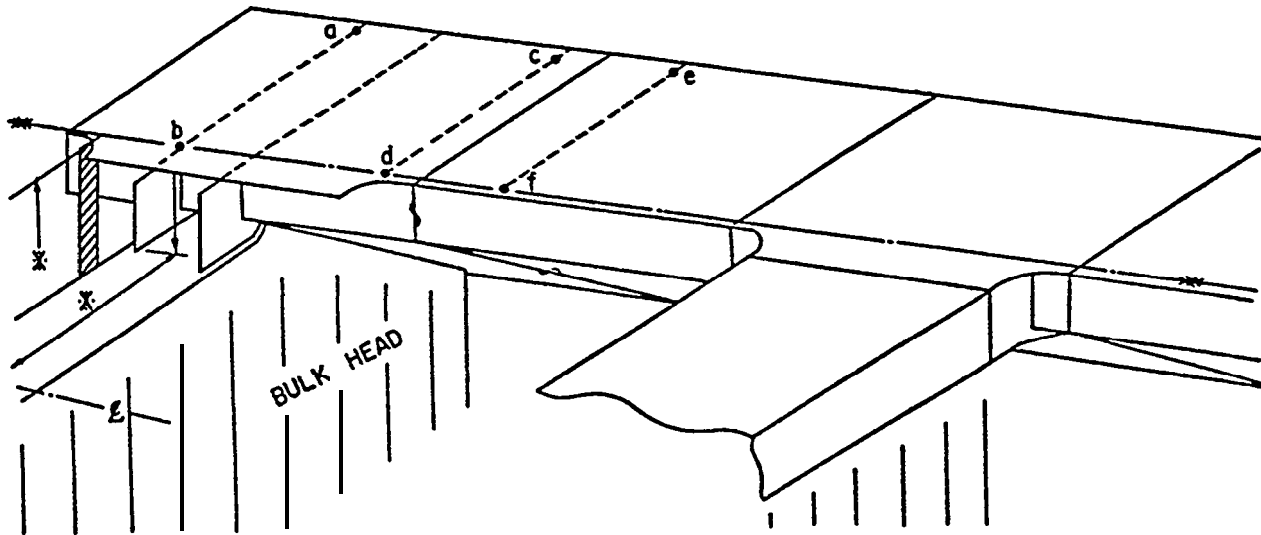

Appendix A, Attachment 3

**BASE LINES FOR SHIPWRIGHT AT ERECTION
 (MARK *)**

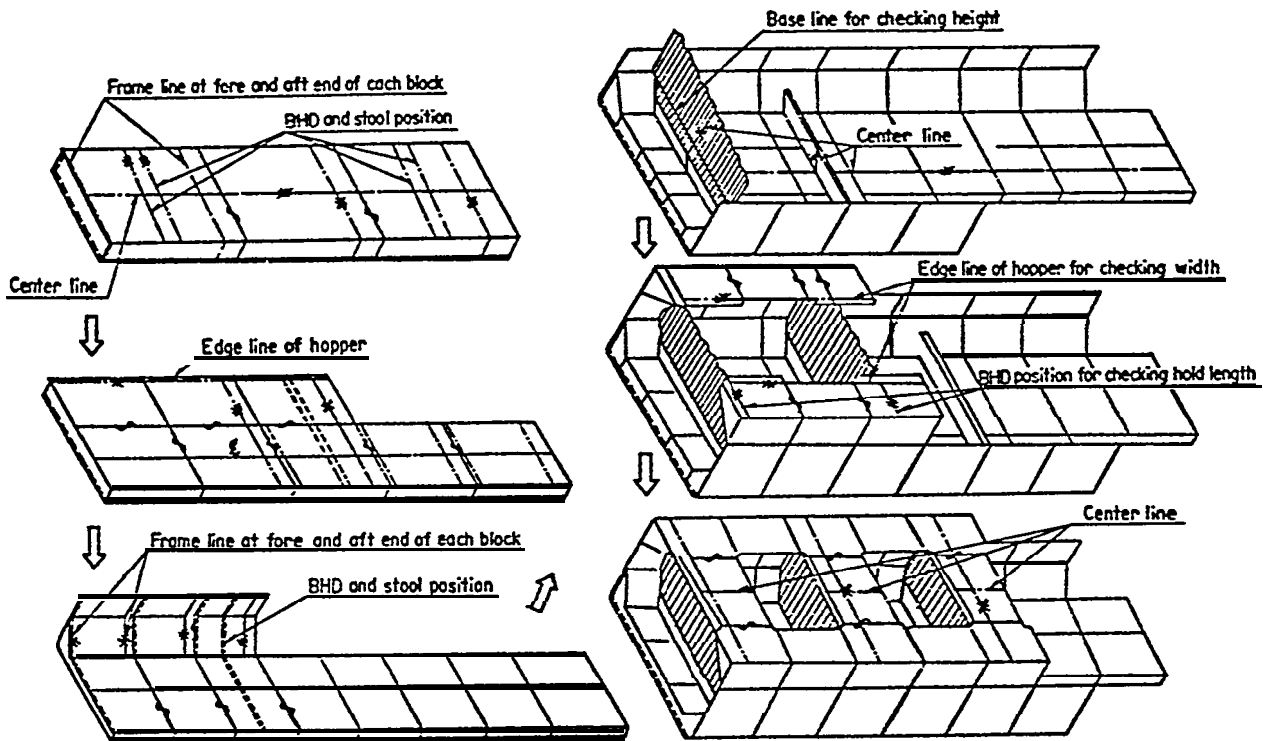

HULL NO.	UNIT	ERECTION SEQ.	HEIGHT (T)	SHIPWRIGHT DOVT. CENTER
----------	------	---------------	------------	----------------------------

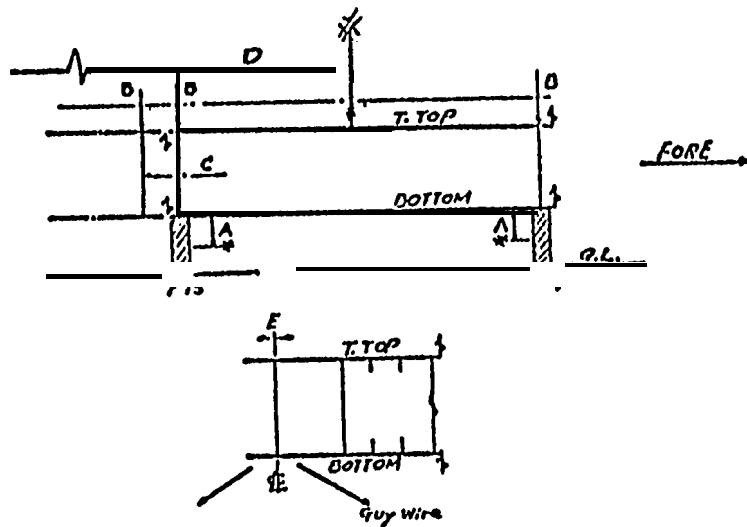

MARK	DESCRIPTION	STUNS	ALICE	CHARGE	NOTICE
A	Bottom Helshut			Worker	Measure at C.GIR by special gauge.
D	Level			Worker AC	Measure at 4 corner points by Transit
C	Space Check			Worker	Measure by ruler
D	Space Check from Dhd.			Worker AC	Measure by ruler
E	Center line check			Worker AC	Measure by guy wire. Measure by Transit

HULL NO.	UNIT	ERECTION SEQ.	HEIGHT (T)	SHIPWRIGHT SIDE
----------	------	---------------	------------	--------------------

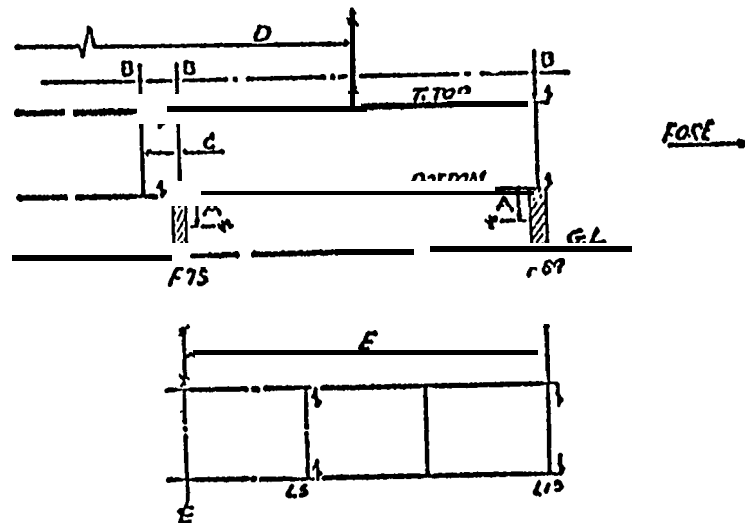

MARK	DESCRIPTION	STUNS	ALICE	CHARGE	NOTICE
A	Bottom Helshut			Worker	Measure at 1.13 by special gauge.
D	Level			Worker AC	Measure at 4 corner points by Transit
C	Space Check			Worker	Measure by ruler.
D	Space check from Dhd. to Dhd.			Worker AC	Measure by ruler.
E	Width from C. line to L13.			Worker	Measure at fore 6 aft end by transit.

Appendix A, Attachment 4

ACCURACY CHECK SHEET			
Ship No.	Block No.	Shop	Condition
			Before combined with bottom plate

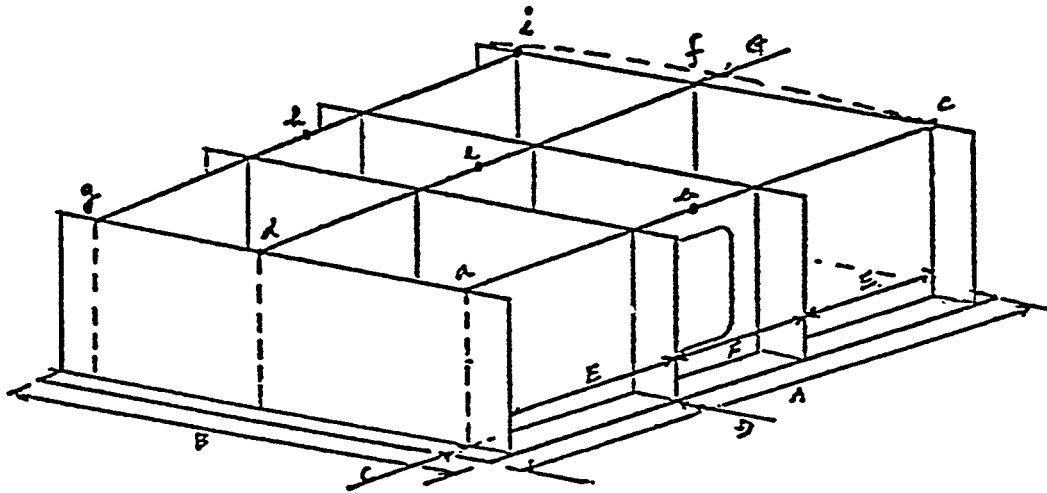

Mark	Item	Dim's in Drawings	Allow. Tol.	Actual Dimension	Chg.	Notice
C			P		Worker	Both side (P.S)
			S		AC	
D	Edge Alignment		F		"	Every Girder Both Side (F.A.)
			A			
E	Girder Spacing		P		"	Every Frame
			S			
F	"			FORE	AFT	Both side (F.A.)
G	Straightness				"	Each girder show maximum.
H	Level			a b c d e	"	9 points a - i
				f g h i j		

Notice: After fitting, welding

Appendix A Attachment 5

ACCURACY CHECK SHEET

Ship No.	Block No.	Shop	Condition
	232 (233)-1/2		Lower Engine Flat Base

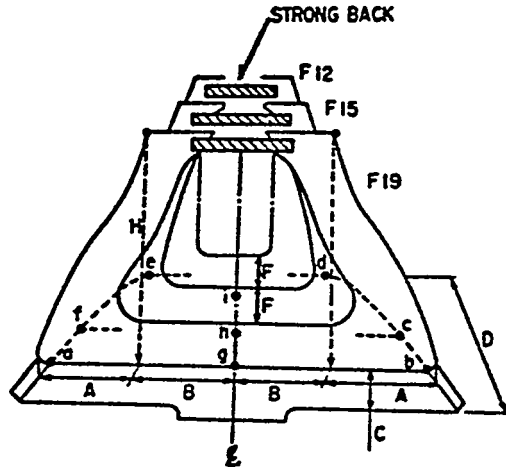

Mark	Item	Dim' S in Drawings	Allow. Tol .	Actual Dimension	Chg.	Notice
G	Lower Eng. Flat Level				AC Worker	a-i 9 points Keep horizontal plane
A B	Width				AC Worker	Plumb at every frame
H	Vertical Height				AC Worker	Plumb at every frame Check the vertical
C	Edge Alignment				"	Aft & Fore
F	Space				"	Each space at frame web
D	Length				"	

Notice 1) Keep the level and fix the flat panel.
2) Need support and strong back.

ACCURACY CHECK SHEET

Ship no.	Block No.	shop	Condition
	232(233)-2/2		Final Assembly

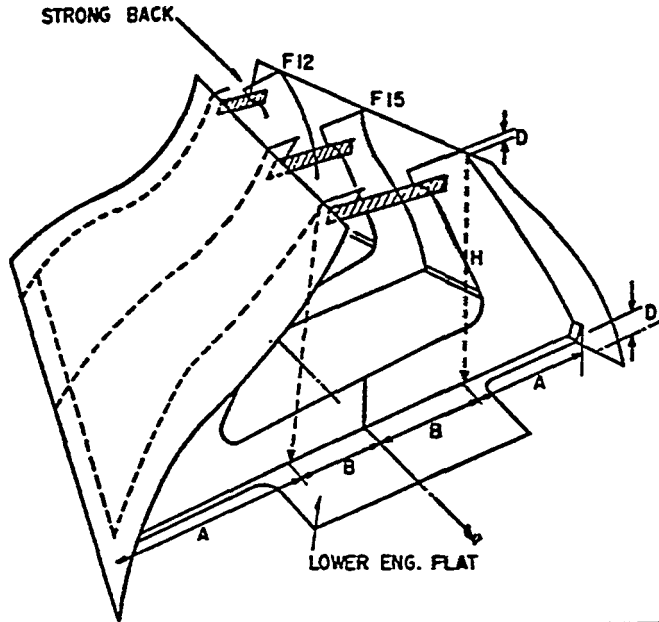

Mark	Item	Dim's in Drawings	Allow. Tol.	Actual Dimension	Chg.	Notice
A B	Width				AC	Plumb Keep horizontalplane
D	Shift				AC Worker	
H	Height				AC	Plumb

Notice After fitting and after welding.

Appendix A, Attachment 6
Curved Panel Base Blocks

1. A.C. Data Diagram

FIG. 1

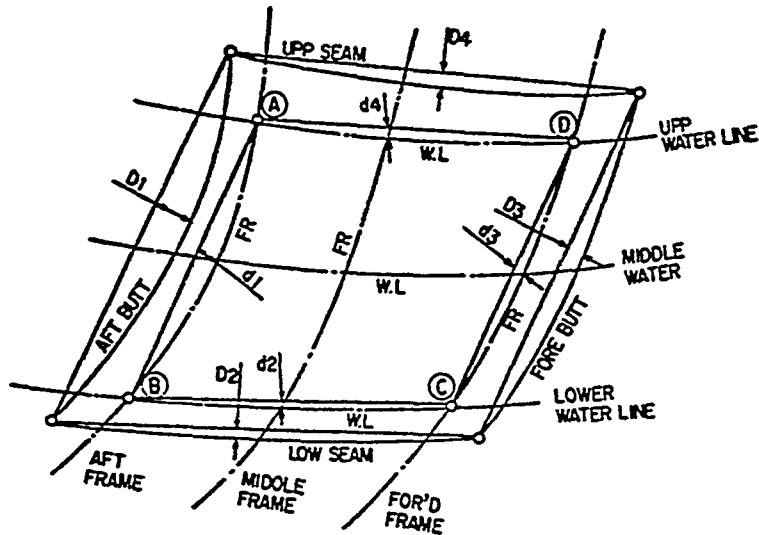
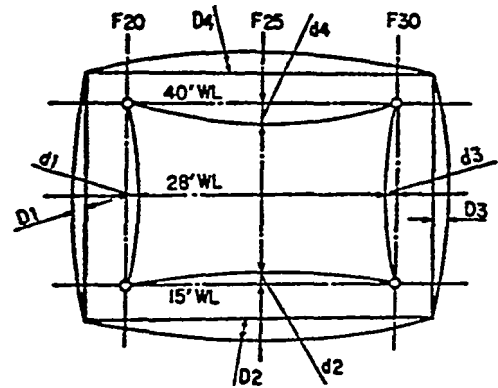

FIG. 2



1. A. C. Data Diagram

It is generally difficult to check deformation of the curved unit shape. However, from the point of view of accuracy control it is necessary to check deformation of the curved unit shape during assembly work.

Then, the deformation checking data of the curved block should be prepared by the mold loft before they begin the assembly work.

Calculate the maximum curvature depths at the aft butt, for'd butt, upper erection seam, and the lower erection seam. Join AD, BC, AB and CD as shown in Fig. 1.

Calculate the upper waterline section's depth and the lower waterline section's depth at the middle frame. And also calculate the aft frame *section's* depth and for'd frame section's depth at middle waterline.

Using the results of the above calculation, draw the checking data diagram as shown in Fig. 2 .

2. A.C. Checking Procedure

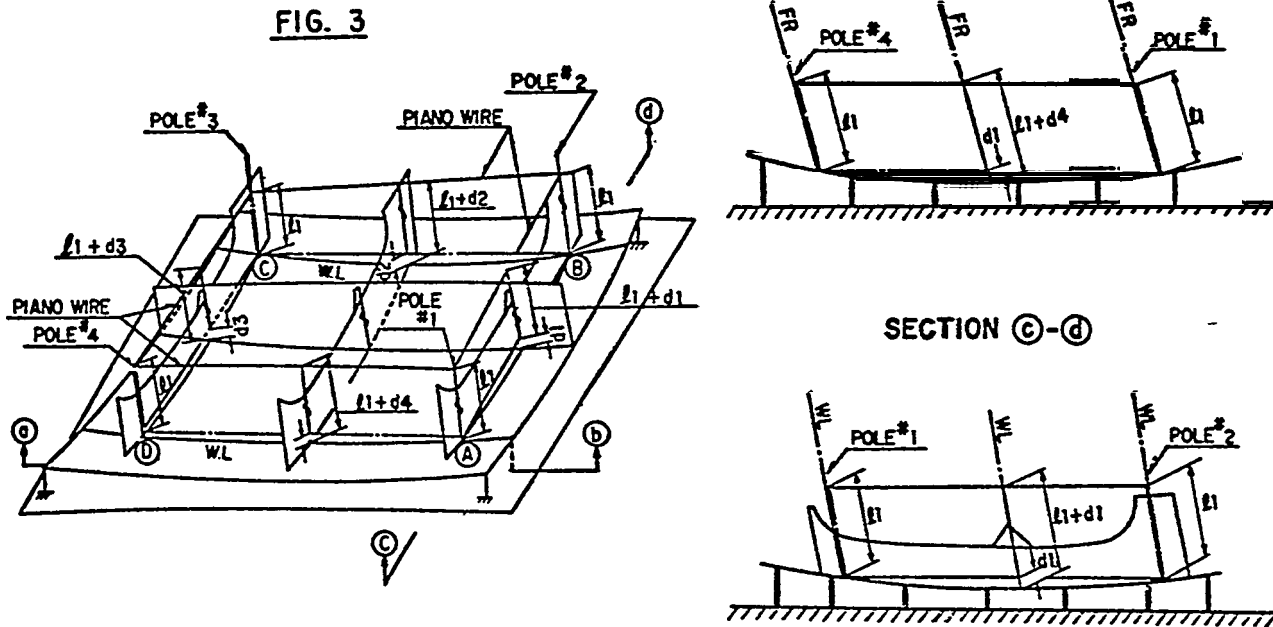

2. A.C. Checking Procedure

Using the checking data diagram, accuracy control activity is carried out as follows:

- (1) After plate joining, check the curvature depth at the aft butt, fore butt, upper seam and lower seam.
- (2) Before welding of the internal structures, set the poles at four (4) points (A, B, C and D) and strain piano wires as shown in the above Fig. 3. Measure the distance between the piano wire and the checking point on the shell plate. Mark down the level mark on each pole for deformation checking.
- (3) After the welding of internal structures, again set the poles at the same points, and check the distances in the same way as mentioned above.

Check the level mark on each pole for deformation of the block.

HULL 751 (Zone-1) BASE LINE & CHECK LINE FOR VITAL POINTS		1
MEMBER & ITEM	MEANING & PURPOSE	NOTES
<p><u>Bottom Floor</u></p> <p><u>Tight Floor & Wall</u></p>	<p>D : Dimension to be checked *The dimension is marked by NC operator and measured after cutting and sub-assembly.</p> <p>F : Guide lines for fitting stiffeners. To be marked by NC burning machine . To be used for fitting stiffeners at sub-assembly Two methods to be useful 1) to be marked at the end of stiffeners (Jig to be used) 2) to be marked at the fixed points.</p> <p>*To be marked at the end of stiffeners.</p> <p>*The dimension should be indicated in case that only one stiffener is different from others.</p>	<p>Limited to the case of the neat cut before sub-assembly.</p>

APPENDIX B

STATISTICAL CONCEPTS IN ACCURACY CONTROL

Performing basic statistical analyses requires understanding of three statistical concepts, mean, standard deviation and the normal distribution curve. Consider the process of marking and cutting flat bars of identical nominal length. Each piece has a measurable difference in length due to the inherent limitations of marking and cutting.

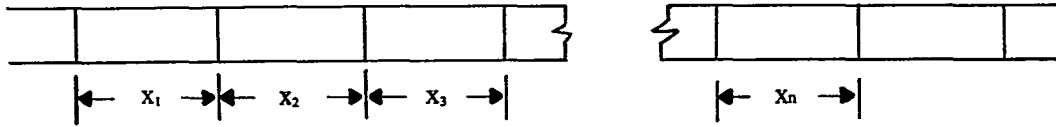

If n of these flat bars are measured, the mean length is:

$$\bar{x} = \frac{\sum_{i=1}^n x_i}{n}$$

and the standard deviation is:

$$s = \sqrt{\frac{\sum_{i=1}^n (x_i - \bar{x})^2}{n - 1}}$$

These two values, the mean and standard deviation, are for a random sample of size n . The random sample is taken from the population of all flat bars produced by a specific process. The population can be considered as infinite in size, with the random sample a finite subset. This sampling procedure can be repeated with a different batch of flat bars, measuring their lengths and calculating a new mean and standard deviation. Generally, the means and standard deviations of the two random samples will not be identical. In theory, an infinite number of random samples of size n could be taken and their means and standard deviations calculated. The laws of statistics state that the mean of all those means will be identical to the mean of the entire population of the flat bars, i.e., all flat bars ever made by a specific, unchanged work process.

Raw data must be grouped to facilitate handling and analysis. Grouping data avoids the need for establishing precision limits and has other advantages. Data grouping is done by measuring the length of each piece in the sample, arranging the data into length classes, and determining the number of flat bars belonging to each class. The result is tabulated on a frequency distribution table and is graphically represented by a frequency diagram or histogram.

The frequency distribution represents the number of occurrences of flat bars in each length class. Given a perfectly controlled process, the frequency distribution will be a **normal distribution**. Where not perfectly controlled the frequency distribution for a sample of measurements can be used to approximate the normal distribution for the process. The following table, histogram, and frequency distribution are examples associated with measuring the length of 100 flat bars:

FREQUENCY DISTRIBUTION TABLE

Length Classes (inches)	Midpoints (x)	Frequency (f) (number of pieces)
104.125-104.375	104.250	5
104.500-104.750	104.625	18
104.875-105.125	105.000	42
105.250-105.500	105.375	27
105.625-105.875	105.750	8
		Sample size: 100

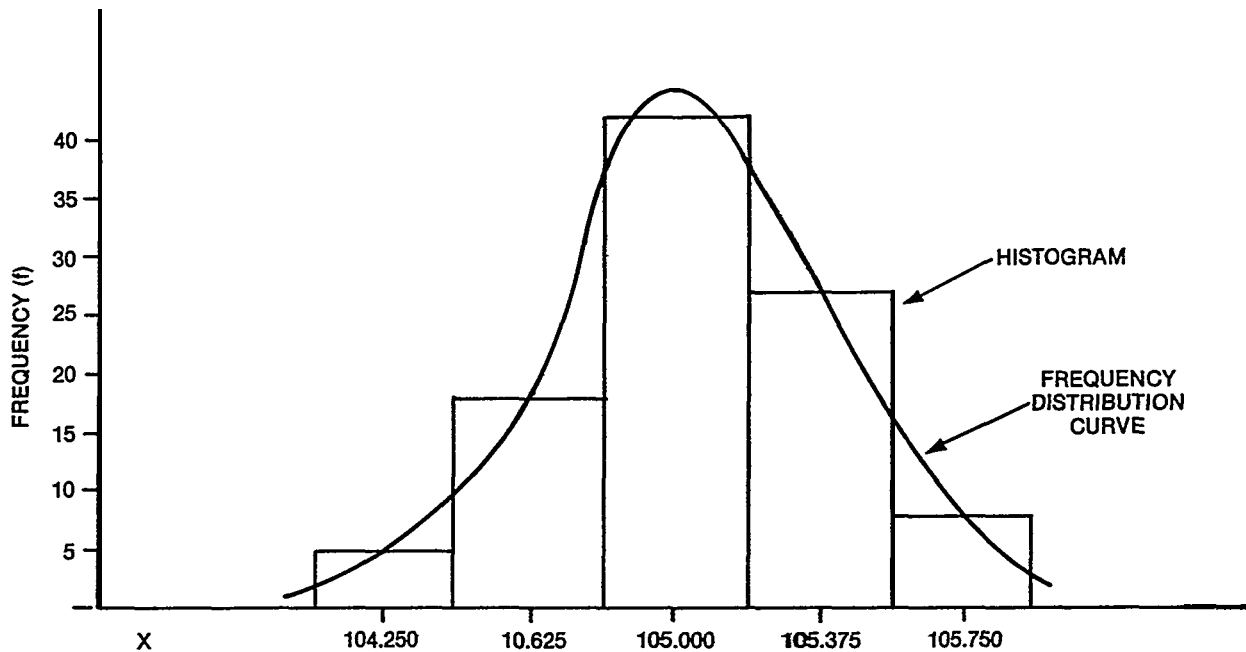

The area enveloped by the curve represents the total number in the sample. Generally, a distribution curve obtained from actual data is not perfectly bell shaped as is the case for a normal distribution. As explained in Attachment 1, there is a way to best fit a normal distribution and determine the pertinent risk factor.

Assuming that the example data is acceptable, the mean value (\bar{x}) of the sample is simply the average length or representative length of all flat bars in the sample. When data is grouped by frequency of occurrence the mean is defined as:

$$\bar{x} = \frac{f_1 x_1 + f_2 x_2 \dots + f_n x_n}{n}$$

and for the example

$$\bar{x} = \frac{(5 \times 104.250) + (18 \times 104.625) + (42 \times 105.000) + (27 \times 105.375) + (8 \times 105.750)}{100}$$

$$\bar{x} = 105.056 \text{ inches}$$

The second fundamental parameter is standard deviation which is a measure of the dispersion or scatter of the observed values around the mean value. If all observed lengths of flat bars tend to concentrate near the mean, the standard deviation is small. If the values tend to be distributed far from the mean, the standard deviation is large.

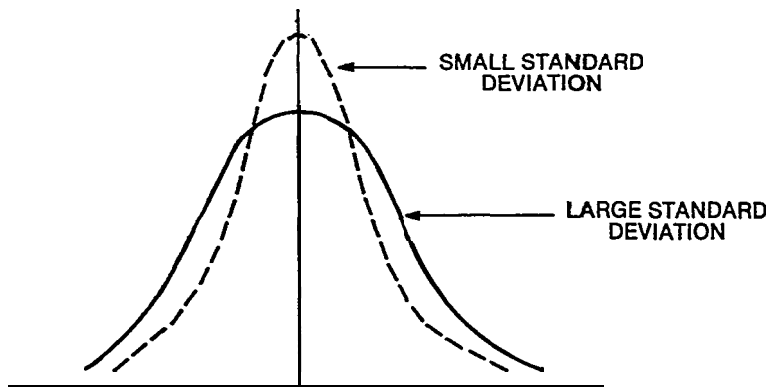

Standard deviation is defined as:

$$s = \sqrt{\frac{f_1 (x_1 - \bar{x})^2 + f_2 (x_2 - \bar{x})^2 \dots + f_n (x_n - \bar{x})^2}{n}}$$

for the example when $\bar{x} = 105.056$
 $s = 0.365$

Random variations from a well controlled process follow the normal distribution which is a symmetrical, bell-shaped curve defined by its mean and standard deviation. The area beneath the curve always represents 100% of the sample being considered apportioned as follows:

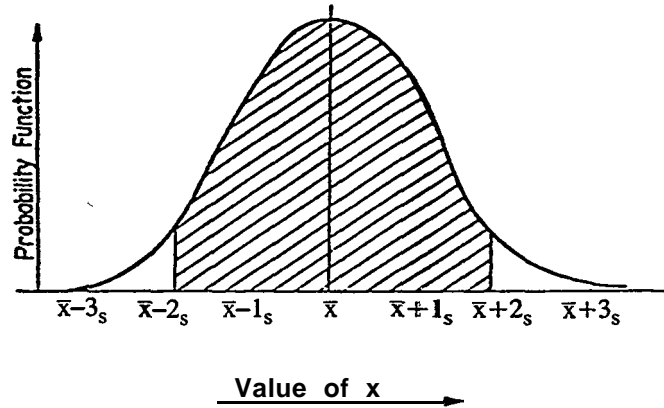

The area between:

- $\bar{x}-s$ and $\bar{x}+s$ (one standard deviation) = 68.27 %
- $\bar{x}-2s$ and $\bar{x}+2s$ (two standard deviations) = 95.44 % (shaded)
- $\bar{x}-3s$ and $\bar{x}+3s$ (three standard deviations) = 99.73 %

These values can be obtained for any value of x from tables incorporated in statistics texts.

APPENDIX B, ATTACHMENT 1

The distributing of controlled processes can be shown to be a normal distribution by applying the “goodness-of-fit” test as a test for normality. This involves calculating the chi-square statistic:

$$\chi^2_o = \sum_{i=1}^k (O_i - f_i)^2 / f_i$$

where k = *number of ranges in measured frequency distribution*

O_i = *frequency of observations in each range*

f_i = *expected frequency in each range for an exactly normal distribution*

This χ^2_o statistic is then compared to χ^2 statistic for a pre-chosen level of significance (α) for k - 1 degrees of freedom. Data in the following table confirm that the variations in shipbuilding work processes do follow the normal distribution. The level of significance, $\alpha = 0.05$, is the risk factor. That is, there is only a 5% chance that the goodness-of-fit test will indicate a normal distribution when one does not exist.

SPECIFIC CHARACTER AND CHECK OF NORMALITY

MAJOR PROCESS	MINOR PROCESS	PARTS	SPECIFIC CHARACTER	MEASURING STANDARD	RESULT OF MEASURE		TEST FOR NORMALITY	
					AVERAGE	STANDARD DEVIATION	χ^2_0 / χ^2 (P .05)	LEVEL OF SIGNIFICANCE TO χ^2_0 %
HULL PREFABRICATION PROCESS	MARKING AND GAS CUTTING PROCESS	HULL PROPER	RIGHT ANGLE OF FINAL MARKING PLATE	DEFRECTION PER ONE METER LENGTH	0	0.91 / 1000	$\chi^2_0 = 1.34 < \chi^2(4.05) = 9.49$	80 - 90 %
			LENGTH OF FINAL MARKING PLATE	+ IS OVER, - IS LESS REGARDING DIMENTION IN DWG OR TAPE AS 0	0.3	1.08	$\chi^2_0 = 5.73 < \chi^2(4.05) = 9.49$	20 - 30 %
			WIDTH OF PLANER PLATE	— DITTO —	0.1	0.69	$\chi^2_0 = 7.68 < \chi^2(6.05) = 12.59$	20 - 30 %
			ANGLE OF EDGE PREPERATION	+ IS OVER, - IS LESS GIVEN 65 DEGREE AS 0	0.1	1.15	$\chi^2_0 = 2.64 < \chi^2(6.05) = 12.59$	80 - 90 %
		INTERNAL STRUCTURE	MARKING DIMENTION	+ IS OVER, - IS LESS GIVEN TAPE DIMENTION AS 0	0	0.55	$\chi^2_0 = 3.26 < \chi^2(2.05) = 5.99$	10 - 20 %
			SECTION STEEL MARKING DIMENTION	— DITTO —	0.3	0.74	$\chi^2_0 = 2.65 < \chi^2(3.05) = 7.81$	30 - 50 %
			CUTTING ACCURACY ALONG REFERENCE LINE.	REFERENCE GIVEN (50) AS 0	0.6	0.76	$\chi^2_0 = 4.85 < \chi^2(3.05) = 7.81$	10 - 20 %
			CUTTING ACCURACY FOR EDGE PREPERATION	— DITTO —	- 0.1	0.96	$\chi^2_0 = 2.40 < \chi^2(4.05) = 9.49$	50 - 70 %
	CUTTING ACCURACY FOR STRUCTURAL		— DITTO —	0.3	1.10	$\chi^2_0 = 2.40 < \chi^2(6.05) = 12.59$	80 - 90 %	
	LENGTH OF BUILT UP LONGITUDINAL		+ IS OVER, - IS LESS GIVEN TAPE DIMENTION AS 0	0.1	0.94	$\chi^2_0 = 5.25 < \chi^2(4.05) = 9.49$	20 - 30 %	
	SUB-ASSEMBLY PROCESS		FITTING POSITION OF STIFFENER	STIFFENER	0.3	0.86	$\chi^2_0 = 3.47 < \chi^2(4.05) = 9.49$	30 - 50 %
			FITTING POSITION OF WFB FRAME FACE PLATE	ACCORDING TO DIMENTION SHOWN IN DWG.	0	1.40	$\chi^2_0 = 3.52 < \chi^2(4.05) = 9.49$	30 - 50 %
		— DITTO —	ACCORDING TO REFERENCE MARK	- 0.1	1.14	$\chi^2_0 = 2.98 < \chi^2(4.05) = 9.49$	50 - 70 %	
		FITTING POSITION OF BUILT UP LONGITUDINAL FACE PLATE	ACCORDING TO DIMENTION SHOWN IN DWG.	- 0.1	0.89	$\chi^2_0 = 4.50 < \chi^2(4.05) = 9.49$	30 - 50 %	

Continued

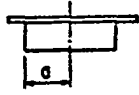
MAJOR PROCESS	MINOR PROCESS	PARTS	SPECIFIC CHARACTER	MEASURING STANDARD	RESULT OF MEASURE		TEST FOR NORMALITY	
					AVERAGE	STANDARD DEVIATION	χ^2_0 / χ^2 (.05)	LEVEL OF SIGNIFICANCE TO χ^2_0
ASSEMBLY PROCESS	JOINTING, CUTTING PROCESS	HULL PROPER	BLOCK LENGTH (MARKING ACCURACY)	DEVIATION AGAINST MOLD TAPE	- 0.1	1.25	$\chi^2_0=5.60 < \chi^2(4.05) = 9.49$	20 - 30 %
			BLOCK WIDTH (MARKING ACCURACY)	— DITTO —	- 0.3	1.13	$\chi^2_0=1.21 < \chi^2(4.05) = 9.49$	80 - 90 %
			RIGHT ANGLE DEGREE AROUND BLOCK	DIFFERENCE BETWEEN BOTH DIAGONAL LENGTH	0.6	1.78	$\chi^2_0=6.90 < \chi^2(5.05) = 11.07$	20 - 30 %
			CUTTING ACCURACY	GIVEN REFERENCE LINE (50) AS CORRECT	0	0.91	$\chi^2_0=2.59 < \chi^2(4.05) = 9.49$	50 - 70 %
	ASSEMBLING PROCESS	PANEL AND FRAMING	LENGTHWISE FITTING POSITION OF PARTS	GIVEN DIMENSION AS 0	0.1	1.41	$\chi^2_0=1.83 < \chi^2(4.05) = 9.49$	70 - 80 %
			TRANSVERSAL FITTING POSITION PARTS	— DITTO —	0	1.42	$\chi^2_0=5.56 < \chi^2(4.05) = 9.49$	20 - 30 %
FITTING POSITION OF PENETRATION PARTS				- 0.4	1.70	$\chi^2_0=2.24 < \chi^2(5.05) = 11.07$	80 - 90 %	
ERECTION PROCESS	SHIPWRIGHTING	BLOCK JOINTING	BOTTOM BLOCK SEAM (AT TACKING).	GIVEN DIMENTION BETWEEN REF. LINES (100) AS NORMAL	2.6	1.58	$\chi^2_0=2.76 < \chi^2(3.05) = 7.81$	30 - 50 %
			BOTTOM BLOCK BUTT (AT TACKING)	— DITTO —	3.0	1.86	$\chi^2_0=1.18 < \chi^2(4.05) = 9.49$	80 - 90 %
			L BHD BLOCK SEAM (AT TACKING)	— DITTO —	2.1	1.93	$\chi^2_0=3.48 < \chi^2(4.05) = 9.49$	30 - 50 %
			L BHD BLOCK BUTT (AT TACKING)	— DITTO —	2.8	2.22	$\chi^2_0=2.63 < \chi^2(4.05) = 9.49$	50 - 70 %
			UPPER DECK BLOCK SEAM (AT TACKING)	— DITTO —	2.5	1.82	$\chi^2_0=4.52 < \chi^2(4.05) = 9.49$	30 - 50 %
			UPPER DECK BLOCK BUTT (AT TACKING)	— DITTO —	2.7	2.04	$\chi^2_0=2.82 < \chi^2(5.05) = 11.07$	70 - 80 %

Refer to a statistics text for χ^2 distribution.

APPENDIX C

EXAMPLES OF VARIATION MERGING EQUATIONS USED BY A/C PLANNERS

I. ERECTION JOINT OF TRANSVERSE WEB FOR A 70,000 DWT TANKER

Assembly Procedure

1. Fit the face plate to the web for the LL block shifted by S_1 .
2. Fit the face plate to the web for the LU block shifted by S_2 .
3. Fit the web to the panel for the LL block at A_1 from the panel edge, where $A_1 =$ the design dimension + 2 mm.
4. Fit the web to the panel for the LU block at A_2 from panel edge.

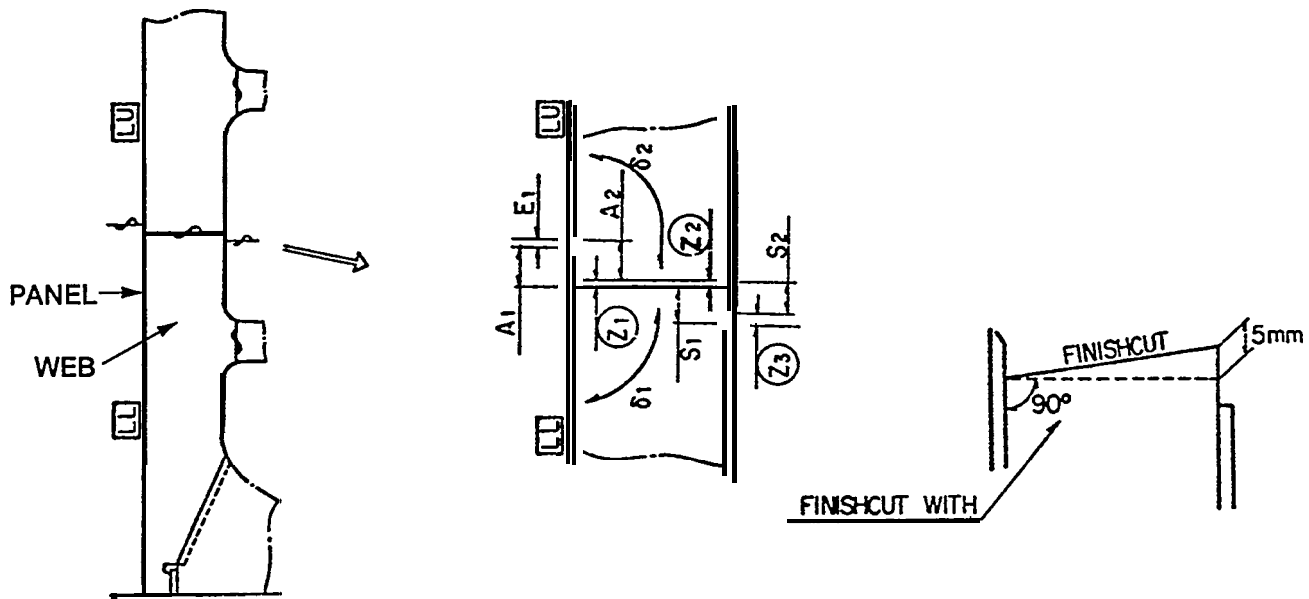

Variation Merging Equation

$$z_1 = (A_1 + E_1) - A_2$$

$$z_2 = Z_1 - (\delta_1 + \delta_2) + (EX_1 + EX_2)$$

$$Z_3 = Z_2 + (S_1 - S_2)$$

EX_1 and EX_2 are inaccuracies due to curved deformation on inclination from vertical during erection which effects accuracy of the web gap Z_2 near the face-plate side. Since it is difficult to obtain measurements of certain dimensions at the erection site, EX_1 and EX_2 were calculated from the measured value of Z_2 , Z_3 was calculated using Z_2 .

ESTIMATED MERGED VARIATION

Dimension	Sample size n	Mean value	Variance	Remarks
δ_1	48	+ 4.8	1-17	Right angle degree of upper end of LL web [After cutting with edge extended 3mm (5mm - 2mm)]
δ_2	56	-0.3	1.00	Right angle degree of lower end of LL web
S1	48	+ 0.7	1.56	Fitting position of face plate to Web (LL)
S2	56	+ 1.5	1.48	Fitting position of face plate to Web (LU)
A1	54	+ 1.8	2.32	Fitting position of web frame LL (L) to panel
A2	82	+ 0.6	2.48	Fitting position of LU web frame to Panel
E1	101	- 1.6	2.91	Accuracy of seam joint of LL x LU (dimension between reference lines after welding)
E x1 + Ex2	-	+ 5.2	4.92	
Estimated Gap				Estimated back-strip welding 2.5%
Z1	-	-0.4	7.71	— d o . — 9 %
Z3	-	-0.5	17.84	

ACTUAL MERGED VARIATIONS

Actual Gap	Sample size n	Mean value \bar{x}	Variance s^2	Confidence intervals* of population variance (confidence level 90%)	Normality test* (significance level 10%)	Actual ratio of back strip
Z1	79	-0.7	8.39	6.63 — 11.25	$\chi_0^2 = 8.50 < \chi_{(7, 0.10)}^2 = 12.02$	2.5%
Z2	79	+0.3	14.80	—	$\chi_0^2 = 11.15 < \chi_{(12, 0.10)}^2 = 18.55$	7%
Z3	61	-0.2	15.30	11.80 — 21.60	$\chi_0^2 = 5.51 < \chi_{(7, 0.10)}^2 = 12.02$	6.5%

● Concepts are addressed in Appendix B and E.

II. ERECTION BUTT OF DECK & BOTTOM LONGITUDINALS OF UPPER WING TANK FOR A 50,000 DWT BULK CARRIER

Assembly Procedure

1. Fit longitudinals on deck and tank-bottom panels maintaining A_2 and A_4 respectively at the aft ends.
2. Provide 3 mm excess and finish cut fwd end of deck panel.
3. Provide some margin at the fwd end of the tank-bottom panel to be cut after the block is set during erection.
4. When joining the tank-bottom block with the deck block, align them by the distance A_3 .

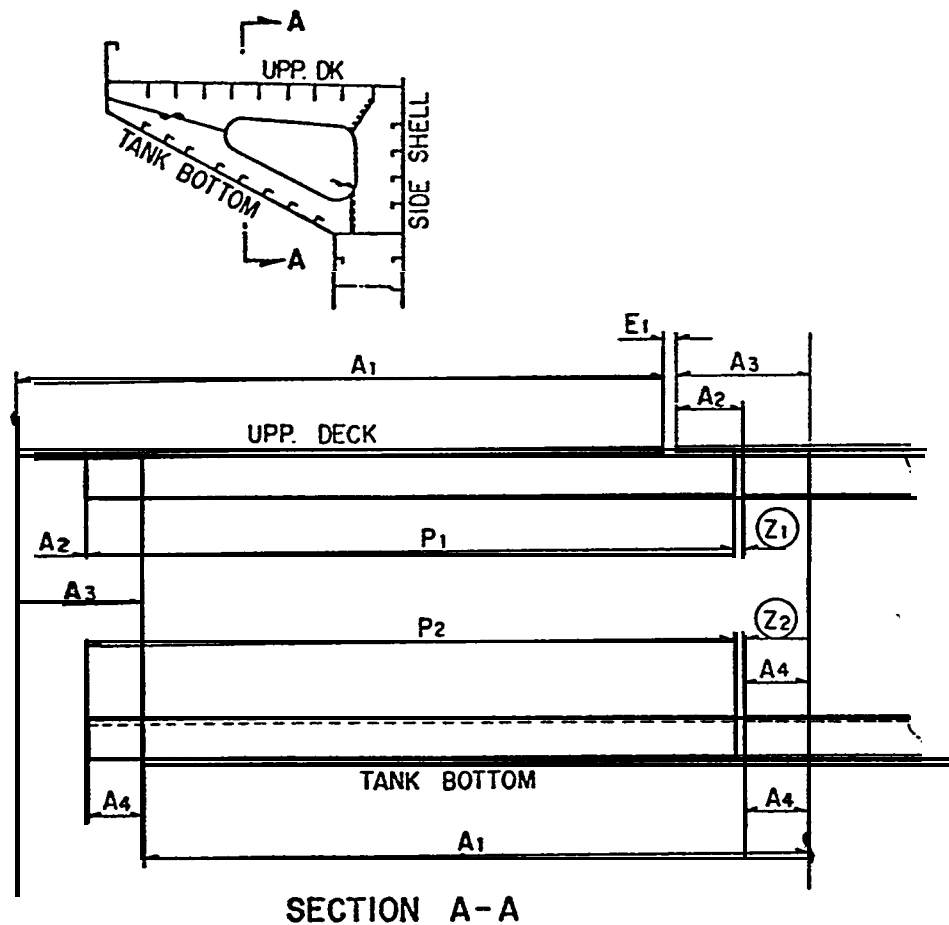

Variation Merging Equations

$$Z_1 = (A + E_1 + A_2) - (A_2 + P_1)$$

$$Z_2 = (A_1 + E_1 + A_3 - A_4) - (A_3 + P_2 - A_2)$$

ESTIMATE MERGED VARIATION

Dimension	Sample size n	Mean value \bar{x}	Variance s^2	<u>Remarks</u>
P1	70	- 0.4	1.88	Length of longitudinal
P2	68	+ 3.8	2.25	Length of tank bottom longitudinal (to be cut 3mm. longer than design dimension)
A1	38	+ 1.3	1.84	Length of upper deck plate
A2	128	+ 0.1	2.23	Fitting position of deck longitudinal
A3	64	+ 1.2	6.04	Longitudinal relative position of upper deck panel and tank bottom panel
A4	128	+ 0.3	4.14	Fitting position of tank bottom longitudinal
E1	42	+ 0.4	3.24	Accuracy of butt connection of upper deck (dimension between reference lines after welding)
Estimated Gap				
Z1	-	+ 2.1	11.42	Estimated ration of back-strip welding 20%
Z2	-	- 2.3	25.78	—— do. —— 8 %

ACTUAL MERGED VARIATIONS

Actual Gap	Sample size n	Mean value \bar{x}	Variance s^2	Confidence intervals of population variance (confidence level 90%)	Normality test (significance level 10%)	Actual ratio of back strip
Z1	102	2.6	9.16	7.5 - 12.0	$\chi^2_0 = 11.69 < \chi^2_{(9, 0.10)} = 14.68$	14 %
Z2	82	- 1.7	22.60	17.8 - 30.0	$\chi^2_0 = 6.96 < \chi^2_{(6, 0.10)} = 10.64$	6 %

III. ERECTION JOINT IN FACE PLATE OF TRANSVERSE WEB

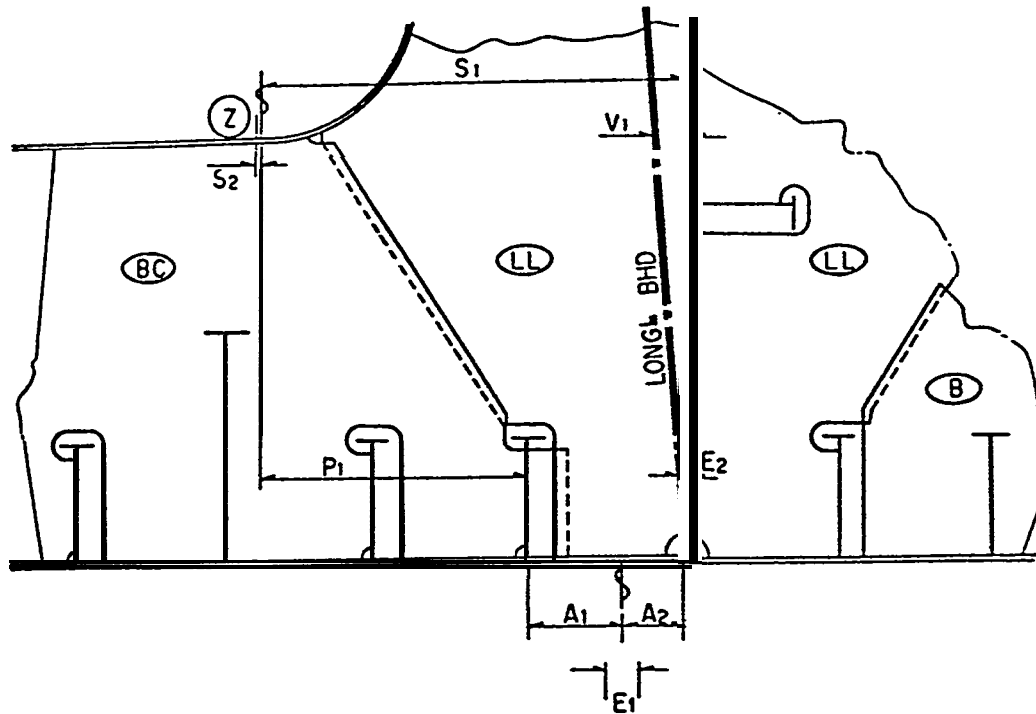

Variation Merging Equation

$$Z = (S_2 + P_1 + A_1 + E_1 + A_2 + E_2) - (S_1 + V_1)$$

Stage	Process	\bar{X}	s	s^2	Remarks
Part Fabrication	P_1 (Stop position of Bottom Trans Fc. PL. to web edge)	0	0.9	0.81	
Sub-block Assembly	S_1 (End position of Fc.PL from L. BHD)	+2	0.8	0.64	Intentionally fit 2 mm longer because of the large variance of Z, 15.30.
	S_2 (Gap of Fc. PL. of Bottom trans)	0	0.8	0.64	
Block Assembly	A_1 (Fitting position of B. long'l)	0	1.4	1.96	Shrinkage by welding of BC x B seams to be investigated.
	A_2 (Marking position of L. BHD)	+2	1.0	1.00	
Erection	V_1 (Deviation of L. BHD)	0	2.0	4.00	Distance between reference lines after welding (2 mm shrinkage to be investigated).
	E_1 (Distance between reference lines)	-2	1.5	2.25	
	E_2 (Installation against L. BHD mark line)	0	2.0	4.00	
Merged Variation	Z	-2	3.9	15.30	Cutting 69% back-strip welding 3.7%

IV. DECREASING THE NUMBER OF PROCESSES BY DESIGN IMPROVEMENT

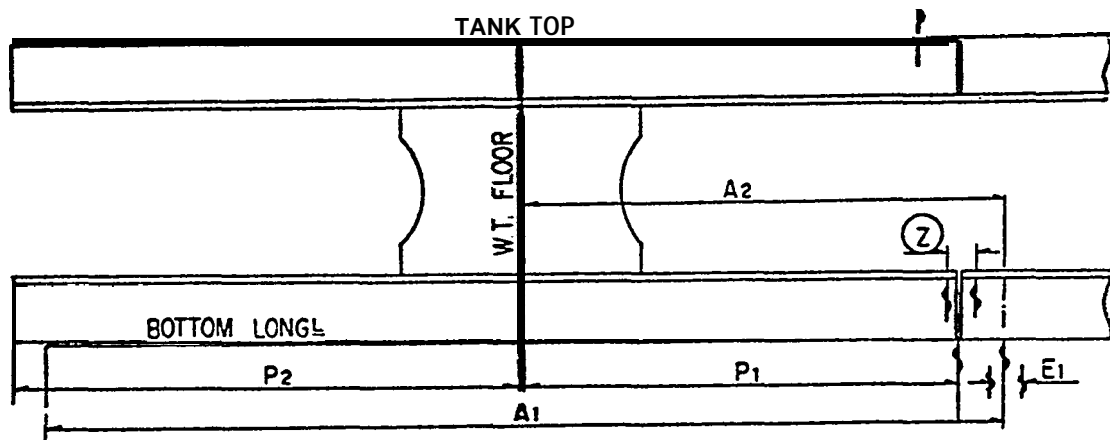

Variation Merging Equation

$$Z_1 = (A_2 + A_1 - A_2 + E_1) - (P_1 + P_2) = A_1 + E_1 - P_1 - P_2$$

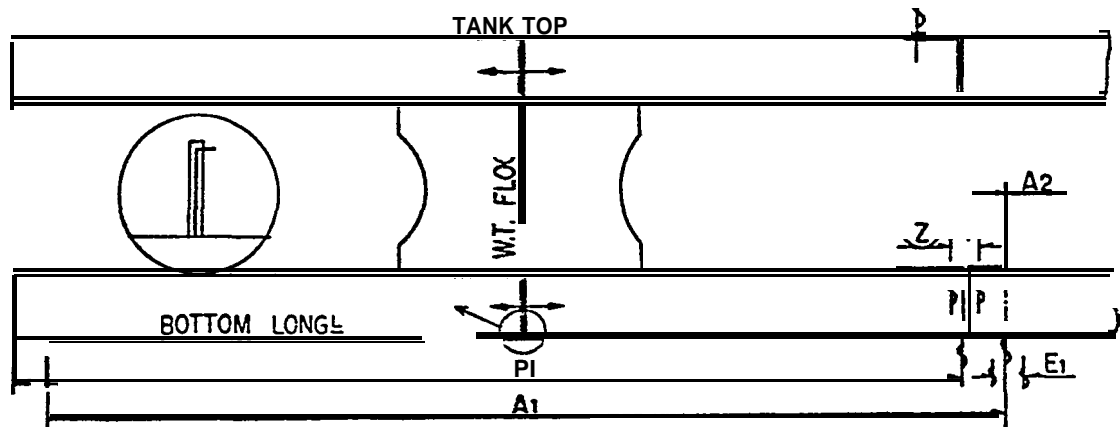

Variation Merging Equation

$$Z_2 = (A_1 + A_2 + E_1) - (A_2 + P_2) = A_1 + E_1 - P_2$$

Z_2 is more advantageous than equation Z , because there are fewer opportunities to generate variations. However, there would be no advantage if the variations of P_1 , P_2 , and P_3 were small compared to A_1 , A_2 , and E_1 . This type of analysis is used to quantitatively determine the best design details for given production capabilities.

V. DECREASING THE NUMBER OF PROCESSES BY CHANGING THE ASSEMBLY SEQUENCE

The number of processes required for the erection butt-joint in bottom longitudinal shown below is one less than for that illustrated in Figure 3-2 of the basic text. Added processes sometimes increase merged variation at the final process. However, an added process which does not contribute significantly to merged variation can be advantageous. In Figure 3-2, the added process would permit the transverse bulkhead to be set more accurately.

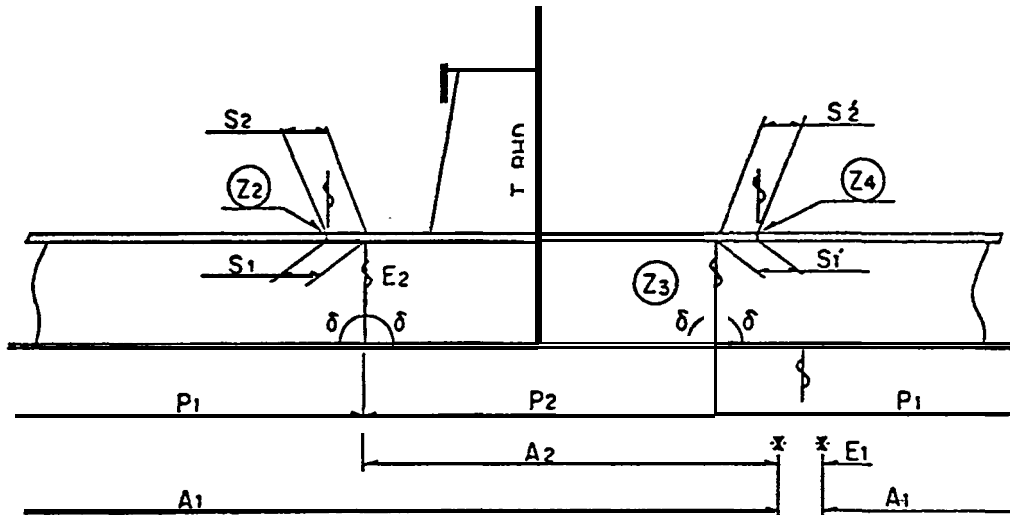

Variation Merging Equations

$$Z_2 = (S_1 - \delta) - (S_2 + \delta) + E_2$$

$$Z_3 = (A_2 + E_1 + A_1) - (E_2 + P_2 + P_1 + A_2)$$

$$Z_4 = (S'_1 - \delta) - (S'_2 + \delta) + Z_3$$

Stage	Process	\bar{X}	s	s ²	Remarks
Part Fabrication	P ₁ (Length of bottom long'l)	-1	1.0	1.00	Negative \bar{X} means on the average the longitudinals, P ₁ , are short.
	P ₂ (Length of penetration piece)	0	1.0	1.00	
	δ (Accuracy of squareness)	0	0.5	0.25	As shown by deviation of the upper most point of bottom long'l edge.
Sub-block Assembly	S ₁ (Gap of Flange PL. of P.)	0	0.8	0.64	
	S ₁ (----- do. -----)	0	0.8	0.64	
	S ₂ (Gap of Flange PL. of Pen Pc.)	0	0.8	0.64	
	S ₂ (----- do. -----)	0	0.8	0.64	
Block Assembly	A ₁ (Length of bottom PL)	+3	1.2	1.44	Shrinkage of main butt to be investigated.
	A ₂ (Edge joint of Pen Pc.)	+3	1.2	1.44	
Erection	E ₁ (Distance between reference lines after welding)	-2	1.5	2.25	2 mm shrinkage after welding to be investigated.
	E ₂ (Butted gap)	+1	1.5	2.25	
Merged Variation	Z ₂	+1	2.0	4.00	Positive \bar{X} means a joint gap exists.
	Z ₃	+1	3.3	10.89	
	Z ₄	+1	3.5	12.25	

APPENDIX D-1



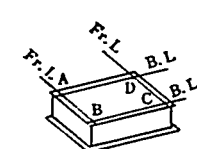
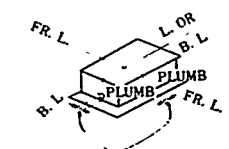

Page D-2 of this Appendix contains a sample from the “Japanese Shipbuilding Quality Standard (Hull Part) -1979”; published by the Research Committee on Steel Shipbuilding, The Society of Naval Architects of Japan, 15-16 Toranomom, 1-Chome, Minato-ku, Tokyo, Japan. Standard ranges and tolerance limits are identified for each item.

Pages D-3 through D-6 show how such accuracy standards were further developed by a shipbuilding firm.

Pages D-7 through D-10 are additional examples of independent accuracy standards development. These also specify “Frequency of Measurement.”

Division		Sub-assembly			UNIT : mm	
Section	Sub-section	Item	Standard range	Tolerance limits	Remarks	
Accuracy of Dimensions	Plate Block Sub-assembly	Twist of Sub-assembly	10	20	Measured as follows :  The point A, B and C are established in the same plane, then measured the deviation of the point D from that plane. May re-assemble partially when the deviation exceed the limits.	
		Deviation of upper / lower panel from Σ or B. L	5	10	 ACCURACY OF THIS DIMENSION	
		Deviation of upper / lower panel from F R.L	5	10		
	Curved plate Block Sub-assembly	Breadth of each panel	The same as for the flat plate Sub-assembly			
		Length of each panel				
		Distortion of each panel				
		Deviation of interior members from skin plating				
		Twist of Sub-assembly		15	25	The same as for the flat plate Sub-assembly
			Deviation of upper / lower panel from Σ or B.L.	7	15	Re-assemble partially when the deviation exceed the limits.
			Deviation of upper / lower panel from F.R.L.	7	15	
	Block Sub-assembly Including Stern frame	Distance between upper / lower gudgeon (a)	± 5	± 10		

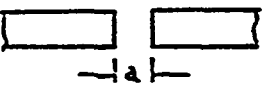
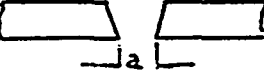

Gap between butt weld edge

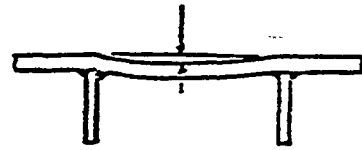
Item	Allowable limit mm	Remarks
<p>1. Butt weld plates</p> 	<p>$a \leq 5$</p> <p><u>In case</u></p> <p>1) $5 < a \leq 16$ (When PL. thick ≥ 10) A $5 < a \leq 10$ (When PL. thick < 10)</p> <p>2) $25 \geq a > 16$ (When PL. thick ≥ 10) A $16 \geq a > 10$ (When PL. thick < 10)</p> <p>3) $a > 25$ (When PL. thick > 10) A $a > 16$ (When PL. thick < 10)</p>	<p>When 'a' exceeds the allowable limit, the edges shall be treated as follows.</p> <p>1) The edge shall be built up by welding with a backing strip, and then back welding shall be done after removing the backing strip and after back chipping-</p>  <p>2-a) When the renewal of a longitudinal member is necessary, the scope of the-renewal shall be decided case by case, with the agreement of the buyer and the classification society. For the other members, the plate of at least 300mm width shall be renewed.</p> <p>2-b) If 2-a is not applicable, the edge shall be built up by welding, and then the butt shall be welded.</p>  <p>3) The members shall be partially renewed in the same way as specified in above paragraph 2-a.</p>
<p>2. Butt weld of sections</p> 	<p>$a \leq 5$</p>	<p>When a exceeds the allowable limit, the gap shall be treated in the same way as the butt weld plates.</p>
<p>3. CES welding</p> 	<p>$17 \leq a \leq 40$</p> <p><u>In case</u></p> <p>1) $40 < a \leq 40 + t$</p> <p>2) $a > 40 + t$</p>	<p>When a exceeds 40mm, the gap shall be treated as follows.</p> <p>1) The edge shall be built up by welding.</p> <p>2) The plate shall be partially renewed.</p>
<p>4. Electro gas welding</p> 	<p>$10 \leq a \leq 30$</p> <p><u>In case</u></p> <p>1) $30 < a \leq 30 + t$</p> <p>2) $a > 30 + t$</p>	<p>1) The edge shall be built up by welding</p> <p>2) The plate sh all be partially renewed</p>



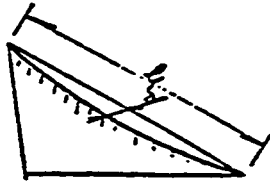

Deformation



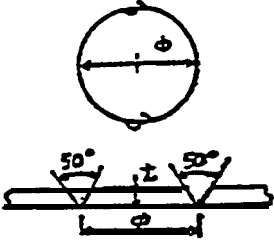
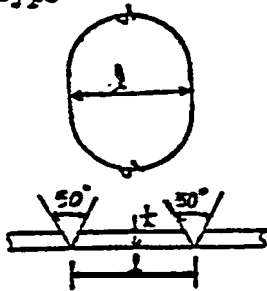
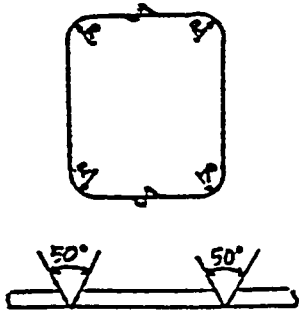

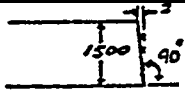
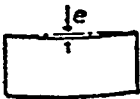
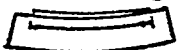
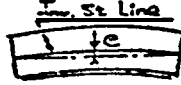

Division	Item	Allowable limit mm
Shell plate	Parallel part side shell	6
	Parallel part bottom shell	6
	Fore and aft part	7
Double bottom tank top plate		6
Bulkhead	Longitudinal bulk-head	7 (t ≤ 13) 8 (t > 13)
	Transverse bulkhead (Swash bulkhead)	8
Strength deck	Parallel part (between 0.6 L ☉)	6
	Fore and aft part	8
	Covered part	9
Second deck	Bare part	8
	Covered part	9
Fore-castle deck Poop deck	Bare part	6
	Covered part	9
Super-structure deck	Bare part	6
	Covered part	9
House wall	Outside wall	6
	Inside wall	6
	Covered part	9
§ Web of girder and trans		7
Δ Floor & girder in double bottom tank		7

Distortion & Straightness (Creature)

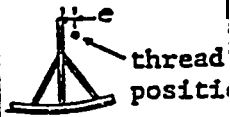
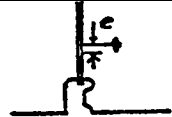
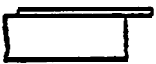
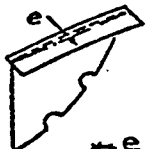
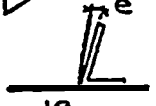
Item	Allowable limit mm	Remarks
1. Distorsion of beams, frames or stiffeners (per 1 span)	1) $\delta \leq 7$ 2) $\delta \leq (5 + \frac{2l}{1000})$ 3) $\delta \leq 12$	1) When $l \leq 1000$ 2) When $1000 < l < 3500$ 3) When $l \geq 3500$
2. Distorsion of girder and long. (per 1 span)	1) $\delta \leq 5$ 2) $\delta \leq (3 + \frac{2l}{1000})$ 3) $\delta \leq 10$	1) When $l \leq 1000$ 2) When $1000 < l < 3500$ 3) When $l \geq 3500$
3. Straightness in the plan of flange and web	± 25 (per 10m length)	
Δ 4. Tr. BKT & stiff. with web (when free edge)	$\delta = l \times \frac{8}{1000}$ (max. 12)	
Δ 5. Pillar (between deck)	1) $\delta = 6$ 2) $\delta = l \times \frac{1:2}{1000}$ (max. 12)	1) When $l \leq 5.000$ 2) When $l > 5.000$ 

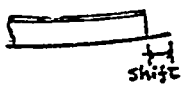
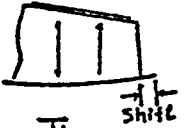
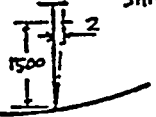
Division	Item	Remarks
HOLE	<p>(1) Circle Type</p> 	<p><u>Important member</u></p> <p>a) when, $t \leq 13$ min $\phi = 200\text{mm}$</p> <p>b) when, $t > 13$ $\phi = 15 \times t$ (standard) max = 450mm</p> <p><u>Other member</u></p> <p>a) when, $t \leq 16$ min $\phi = 200\text{mm}$</p> <p>b) when, $t > 16$ $\phi = 12 \times t$ (stan rd)</p>
	<p>(2) Oval Type</p> 	<p>- do.-</p>
	<p>(3) Square Type</p> 	<p>for temporary hole (min "R" = 150mm)</p>

SHOP	ITEMS	ALLOWABLE TOLERANCE	FREQUENCY OF MEASURING	REMARKS
Marking & Gas Cutting Section) Fb)	*Check line for gas cutting of angles (after marking)	$e = \pm 1.5/64''$	8 pc/day (piece/day)	
	*Check line for gas cutting of angles (after cutting)	$e = \pm 1/32''$	5 pc/day	
	*Length of angles (after cutting)	$e = \pm 1.5/64''$	5 pc/day	
Internal Member)	*Normality after gas cutting (Right Angle)	2/1500	5 pc/day	
	*Check line for gas cutting	$e = \pm 1/32''$	Do	
	*Length after gas cutting	$e = \pm 3/64''$	Do	
	*Width after gas cutting	$e = \pm 3/64''$	Do	
Flame planer Flat shell plate (flat plate)	*Length & Width after cutting	$e = \pm 1.5/64''$	5 pc/day	
	*Straightness	$e = \pm 1/64''$	2 pc/week	
	*Bevel Angle	$e = \pm 2.0 \text{ deg.}$	5 pc/day	
	*Normality (Right Angle)	$e = \pm 2/1500$	2 pc/week	
Bending (Section) (Plate)	*Length of frames after bending	$e = \pm 1.5/32''$	5 pc/day	Girth length  
	*Straightness of inverted straight line of frames after bending	$e = \pm 3/32''$	5 pc/day	
	*Round gunwale plate & Bilge plate	$e = \pm 1/8''$	All	  
*Setting degree of template	$e = \pm 1/4''/2''$	All		
*Discrepancy between template and end of plate	$e = \pm 1/4''$			

SHOP	ITEM	ALLOWABLE TOLERANCE	FREQUENCY OF MEASURING	REMARKS
<u>Bending</u>	*Height of sight seeing line	$e = \pm 1.5/16''$	5 pc/day	
	*Discrepancy of sight seeing line between templates and thread	$e = \pm 1/4''$	5 pc/day	
<u>Sub-Assembly</u>	*Positioning of stiffeners (FB. BKT) on a web plate	$e = \pm 1/32''$	8 pc/day	
	*Positioning of face plate to a web plate (keep shift dimension)	$e = \pm 1/32''$	8 pc/day	
	*Flatness of sub after sub-assembly	$e = \pm 1/8''$ (LS 31' 14'') $-e = \pm 1/4''$ (L 31' 14'')	8 pc/day	
	*Fitting angle of stiffeners to a web plate	$e = \pm 3 \text{ deg.}$		
	*Deformation of sub-unit	$e = \pm 1/4''$	8 pc/day	
<u>Assembly Fitting</u>	*Shift dimension between skin plates and frames/girders	$e = \pm 1.5/32''$	5 pc/day	
	*Shift dimension between skin plates and trans. web/floors	$e = \pm 1.5/32''$	5 pc/day	
	*Fitting angle between trans. web and skin plates	$e = \pm 5/1500$	5 pc/day	
	*Fitting angle between frames and skin plates (at the top)	$e = \pm 1/8''$	5 pc/day	
	*Level	$e = \pm 1/4''$	All	
	*Perpendicularity check by a plummet	$e = \pm 1/16''$ (at the end point)	All	
	*Flatness of a unit	$e = \pm 1/4''/L$	20%	

SHOP	ITEM	ALLOWABLE TOLERANCE	FREQUENCY OF MEASURING	REMARKS
<u>Assembly</u>				
<u>Marking</u>	*Length of plates	$e = \pm 1/8''$ (curved)	All	
	*Width of plates	$e = \pm 1.5/16''$ (plane)	All	
	*Diagonal length of plates (squareness check)	$\Delta L = \pm 1/4''$ (curved) $\Delta L = \pm 1/8''$ (plane)	All	 $\Delta L = L_1 - L_2$
	*Marking lines by hand	$e = \pm 1/8''$ (curved)	4 units/ 2 days	
	*Straightness of plate edge	$e = 1/16''/L$	20%	
	*Width of corrugate	$e = 1.5/16''$	All	
	Height of corrugate	$e = 1/16''$	All	
	Normality of corrugate	$e = 1.5/16''$	All	
<u>Assembly</u>				
<u>Gas Cutting</u>	*Check line for gas cutting	$e = \pm 1/32''$	5 pc/day	
	*Depth of bevel	$e = \pm 1/32''$	5 pc/day	
	*Bevel Angle	$e = \pm 2.0 \text{ deg.}$	5 pc/day	
	*Straightness of plate edge	$e = \pm 1.5/32''$	20%	

SHOP	ITEM	TOLERANCE	FREQUENCY MEASURING	REMARKS
<u>ERECTION</u> Bottom Shell	*Positioning: (Length rise) Measure on the check points on berth	$e = \pm 1/8''$	starting unit only	
	*Positioning: (Height) Measure at the most forward frame (2 points)	$e = \pm 1/4''$	All Units	By gauge
	*Level: (Between left side and right side) Measure on the points at forward edge	$e = \pm 1/4''$	All units	Pay attention to twist
	*Positioning: (Between left side and right side) Measure at the forward butt	$e = \pm 1/8''$	All units	Plumb down to the base line on berth
	*Connecting part between units: Check the levels at seams and butts	$e = \pm 1/8''$	All units	
	*Discrepancy of ship's center	$e = \pm 1/8''$	All units	Measuring by transit

APPENDIX E

Analysis of Shrinkage in Double-bottom Floor Caused by Gas Cutting and by Welding and Line Heating

Abilities to predict shrinkage caused by high temperatures and provide compensatory shrinkage allowances are crucial for minimizing rework during erection. The problems are exacerbated by the many different relatively complicated parts and subassembly shapes that characterize shipbuilding. A double-bottom (DB) floor sub-block is a good example.

As shown in Figure 1, more than one DB floor panel is usually cut from a single plate. Shrinkage is different for the panel edges which are different. The tortuous cutting paths for all "1" edges cause higher heat inputs. Thus, for each of them shrinkage is greater than for any of the "2" and "3" edges which are straight.

Generally, except for more applied research, shipbuilders have done as much as can be done by modifying part shapes, changing cutting-path sequences, and minimizing heat input. As shrinkage persists, it is counteracted by competitive shipbuilders with statistical methods for determining excess allowances.

Figure 2 shows how A/C engineers have organized for and required the collection of statistical data following gas cutting before a part is released from a part-fabrication shop to a sub-block assembly section. The data are organized as separate histograms for each edge and provision is made to incorporate calculated mean values and standard deviations accordingly. An example of how they were calculated is shown in Figure 3.

Data is again collected and analyzed in the same manner following line heating to remove distortion caused by welding during sub-block assembly. The heat introduced by these two processes causes additional shrinkage, see Figures 4 and 5. Also, the measurements to obtain these data serve as a check before a sub-block is released for block assembly.

However, the data recorded during sub-block assembly is an indicator of total shrinkage due to gas cutting plus welding and line heating. Thus, it is necessary to calculate the mean values and standard deviations of just that shrinkage caused by welding and line heating during sub-assembly as shown in Figure 6.

With reference to Figure 6, s_{AG} and s_{AW} are about the same. Also, s_{AW} for both the tank top and bottom shell are only different from each other by less than 0.333 mm. The same can be said for the bulkhead and center edges.

Considering the values for \bar{x}_{AL} and s_{AL} , allowances for excess are proposed as shown on the left side of Figure 7. The right side shows associated probabilities for rework. These percentages indicate that nearly 70% of the edges of all such sub-block assemblies will make good connections.

Tolerance limits establish whether rework is necessary and indicate what kind of rework is required:

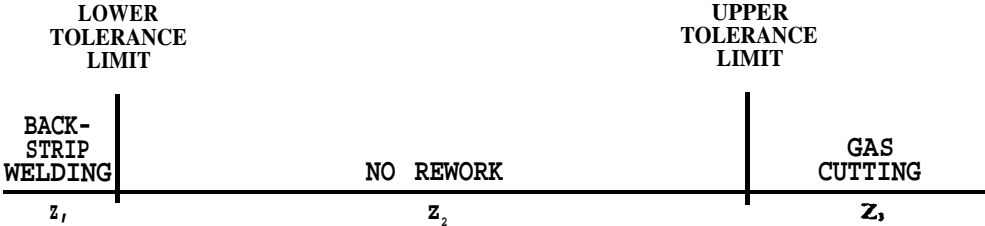

However, for part dimensions which are beyond the upper tolerance limit, i.e., too large, rework by gas cutting should be deferred because during sub-block assembly

- adjacent parts if near their lower tolerance limits could compensate, and/or
- predicted shrinkage during welding and line heating could compensate.

Thus providing a fourth range for “possibly no rework” is productive:

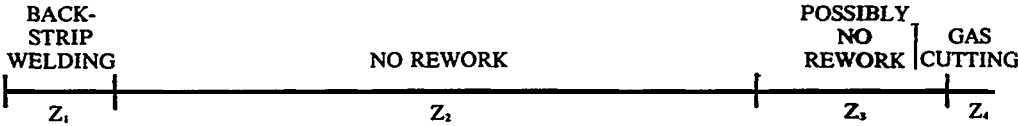

With A/C data accumulated during normal operations, statistics provides a way to predict the effect of a specific excess allowance. The prediction is expressed as the percentages of parts which will during sub-block assembly require:

- rework by back-strip welding,
- no rework,
- possibly no rework, and
- rework by gas cutting.

Typical actions which result from such predictions include:

- investigating how part shapes and gas-cutting sequences effect shrinking, and/or
- applying a proposed excess allowance as shown in Figure 9.

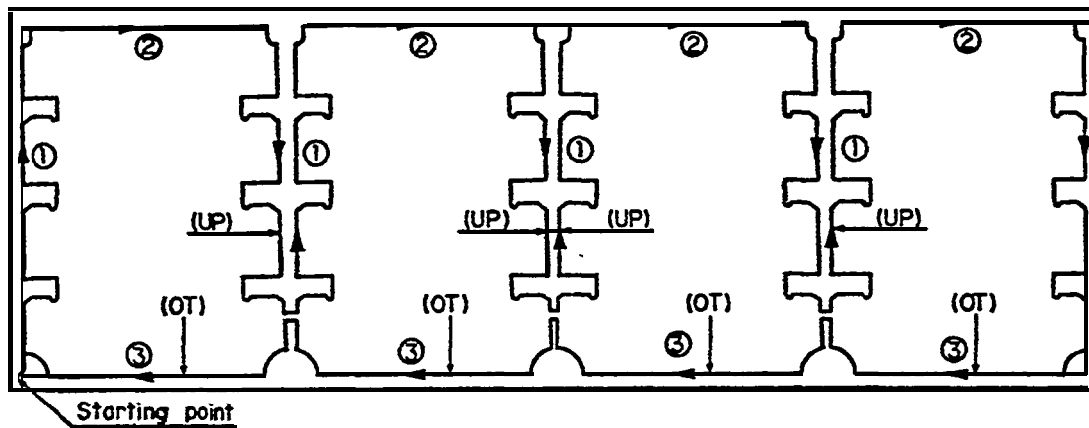

FIGURE 1:

DISTRIBUTION DIAGRAM SHRINKAGE DUE TO GAS CUTTING

\bar{x} = VARIATION MEAN
s = STANDARD DEVIATION

SYMBOL PIECE	\bar{x}	s	NOTE
	0	0.707	* MARK EXCLUDED

SYMBOL PIECE	\bar{x}	s	NOTE
	-1.200	1.414	

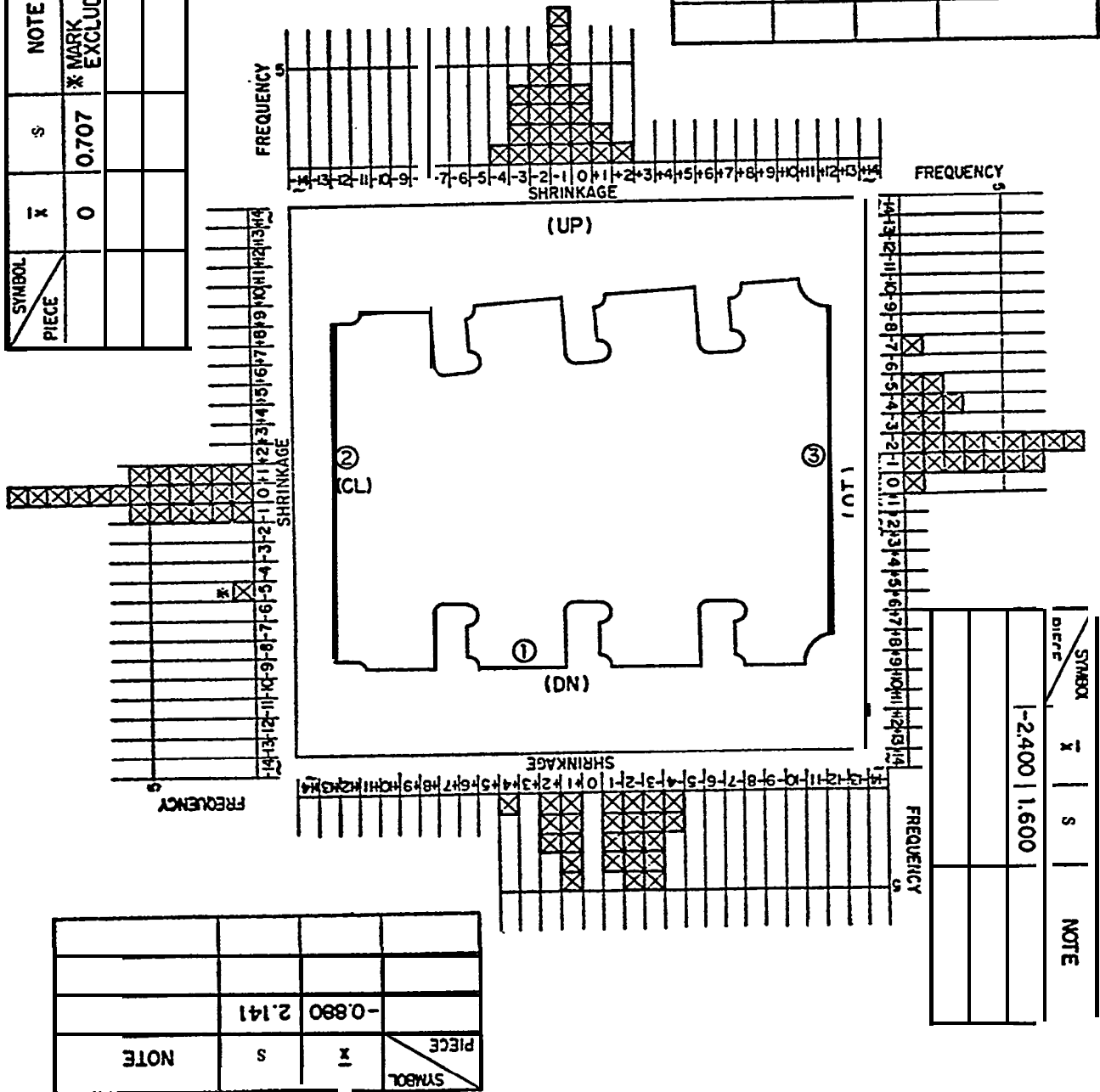

SYMBOL PIECE	\bar{x}	s	NOTE
	-0.880	2.141	

SYMBOL PIECE	\bar{x}	s	NOTE
	-2.400	1.600	

FIGURE 2:

EXAMPLE OF CALCULATIONS
FOR FIGURE 2

[UP)

x_i	f_i	$x_i f_i$	$x_i^2 f_i$
- 4	1	- 4	16
- 3	4	-12	36
- 2	5	-10	20
- 1	8	- 8	8
0	4	0	0
+ 1	2	+ 2	2
+ 2	1	+ 2	4
TOTAL	25	$\Sigma = -30$	86

$$\bar{x} = \frac{\Sigma x_i f_i}{\Sigma f_i} = \frac{-30}{25} = -1.200$$

$$s^2 = \frac{1}{n} \Sigma x_i^2 f_i - \bar{x}^2$$

$$= \frac{1}{25} (86) - 1.440 = 3.440 - 1.440 = 2$$

$$s = \sqrt{2} = 1.414$$

FIGURE 3:

DISTRIBUTION DIAGRAM
SHRINKAGE DUE TO CUTTING,
WELDING & LINE HEATING

\bar{x} = VARIATION MEAN
s = VARIATION MEAN

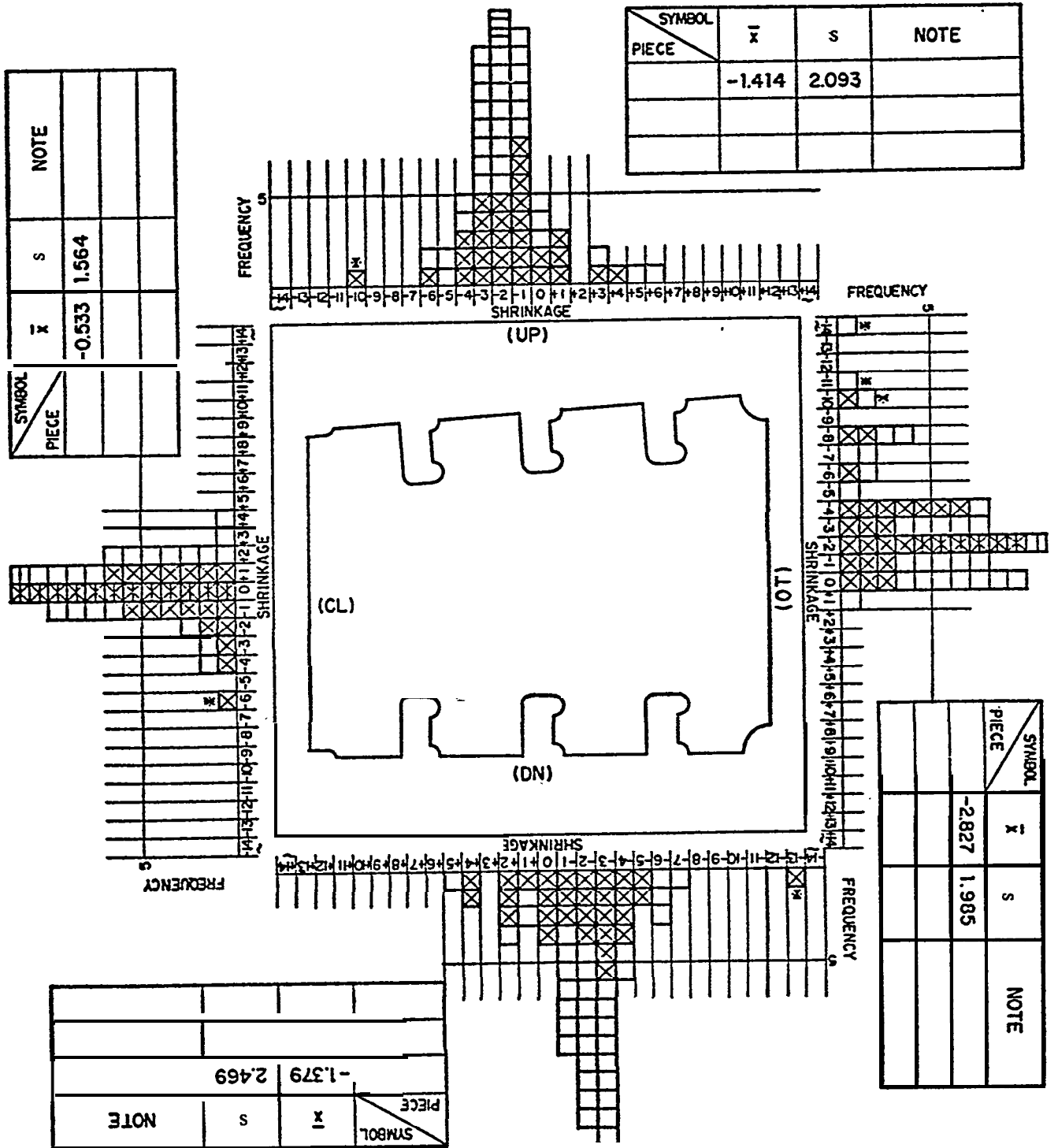

FIGURE 4:

**EXAMPLE OF CALCULATIONS
FOR FIGURE 4**

(UP)

x_i	f_i	$x_i f_i$	$x_i^2 f_i$
-6	1	-6	36
-5	0	0	0
-4	3	-12	48
-3	5	-15	45
-2	5	-10	20
-1	8	-8	8
0	2	0	0
+1	3	3	3
+2	0	0	0
+3	1	3	9
+4	1	4	16
TOTAL	29	-41	185

$$\bar{x} = \frac{-41}{29} = -1.414$$

$$s^2 = \frac{185}{29} - 1.999 = 6.379 - 1.999 = 4.380$$

$$s = \sqrt{4.380} = 2.093$$

FIGURE 5:

MEAN

	PART FABRICATION	PART FABRICATION & SUB-BLOCK ASSEMBLY	SUB-BLOCK ASSEMBLY
	$\bar{X}_{\Delta G}$ (DUE TO GAS CUTTING)	$\bar{X}_{\Delta L}$ (DUE TO GAS CUTTING, PLUS WELDING, AND LINE HEATING)	$\bar{X}_{\Delta W} = \bar{X}_{\Delta L} - \bar{X}_{\Delta G}$ (DUE TO WELDING & LINE HEATING ONLY)
T. TOP (UP)	— 1.200	— 1.414	— 0.214
B. SHELL (DN)	— 0.880	— 1.379	— 0.499
L. BHD (OT)	— 2.400	— 2.827	— 0.427
CENTER (CL)	0	— 0.533	— 0.533

UNIT: mm

STANDARD DEVIATION

	S _{ΔG}	S _{ΔL}	S _{ΔW} = $\sqrt{S_{\Delta L}^2 - S_{\Delta G}^2}$
T. TOP (UP)	1.414	2.093	1.543
B. SHELL (DN)	2.141	2.463	1.230
L. BHD (OT)	1.600	1.985	1.175
CENTER (CL)	0.707	1.564	1.395

UNIT: mm

- ΔG Gas cutting process.
- ΔW Welding and line heating processes.
- ΔL Cutting plus welding and line heating processes.
- $S_{\Delta W}$ Is obtained from the theorem of variance:

$$S_{\Delta L}^2 = S_{\Delta G}^2 + S_{\Delta W}^2$$

FIGURE 6:

		PROBABILITIES			
	Proposed Excess	Z ₁ Rework By Back-strip Welding	Z ₂ No Rework	Z ₃ Rework Possible In Next Process	Z ₄ Rework By Gas Cutting
(UP)	+1	10.9%	64.0%	19.8%	5.3%
(DN)	+1	14.4%	57.1%	19.8%	8.7%
(OT)	+2	13.8%	68.0%	15.4%	2.8%
(CL)	±0	5.9%	77.7%	15.4%	1.0%

FIGURE 7:

EXAMPLE CALCULATION FOR "UP" SIDE

$\bar{x} = -1.414$ $S = 2.093$

$$t = \frac{x_i - \bar{x}}{S}$$

	x_i mm	t
Z_1	-6	
	-5	
	-4	-1.236
Z_2	-3	-0.757
	-2	-0.280
	-1	0.198
Z_3	0	0.676
	+1	1.153
	+2	1.631
Z_4	+3	
	+4	

Back strip welding	Z_1	$t < -1.236$	$F_n = 0.11$	11%
No rework	Z_2	$t = -1.236$	0.75	64%
		$t = 0.676$	-0.11	
			0.64	
Possibly no rework	Z_3	$t = 0.676$	0.95	20%
		$t = 1.631$	-0.75	
			0.20	
Gas cutting	Z_4	$t > 1.631$	0.05	5%

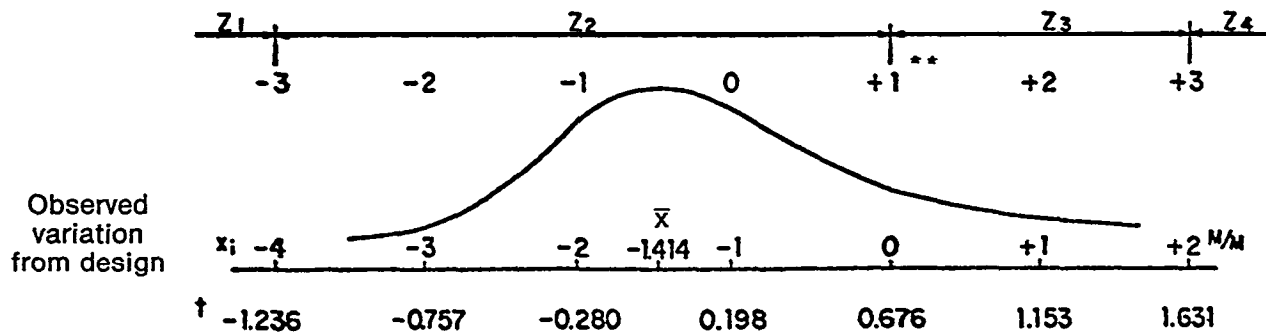

**Variation from design with 1mm excess allowance.

In this example, variation from the design dimension beyond -4mm requires back-strip welding and variation beyond + 2mm always requires gas-cutting. The "possibly no rework" range applies to variations between 0 and + 2mm for which the upper limit was established based upon the shipyard's experience. The values of F_n used to obtain the percentages of work for each region, are calculated using a normal distribution with the means and standard deviations obtained as shown in Figures 1 through 6 for the region limits given above.

FIGURE 8:

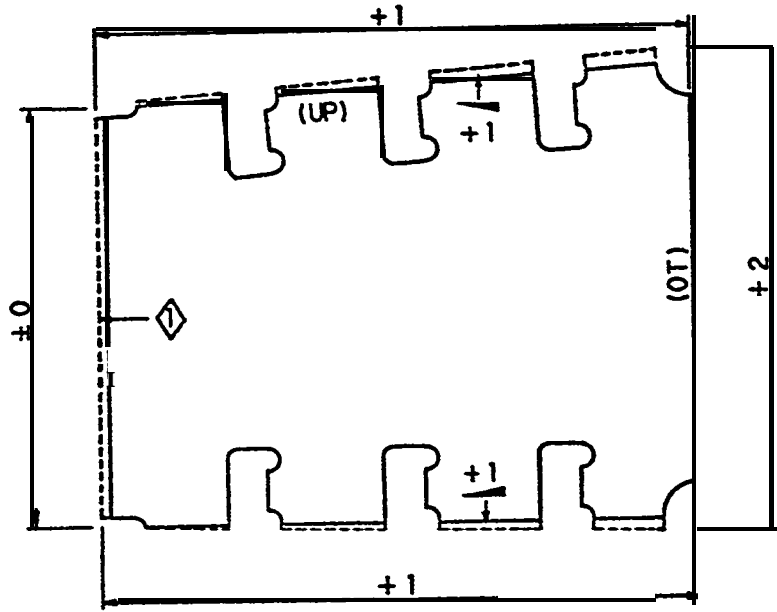

FIGURE 9:

CONTROL CHARTS

Accuracy control (A/c) is based on the variation of products manufactured in the same manner. Even for controlled processes, i.e., where work circumstances do not change, some chance or random variation is normal. As variation is expected, A/C is also concerned with detecting when a process is deviating from its controlled condition. In other words, A/C engineers must be alert for variations which are not due to chance as they are indicators that something or someone is changing how work is being performed.

A/C engineers employ two kinds of charts for control purposes. One is for measurements such as the lengths of flat bars and the other addresses frequencies or counted data, e.g., the number in a sample of 100 that require rework. Both charts employ central lines indicating the average performance expected of a process and upper and lower control-limit lines. The limits are chosen so that values between them represent only normal, random variation. Values beyond the upper and lower control limits indicate that a work process is out of control. By plotting values of samples taken periodically, A/C engineers can also detect a drift toward loss of control.

Control of a work process is facilitated by maintaining plots of mean value (\bar{x}) and range (R) or standard deviation (s). As the population mean and standard deviation are generally unknown, they are estimated by first obtaining a number of samples (k), each of the same size (n). The mean (\bar{x}) of the sample mean (x_i) is calculated as:

$$\bar{\bar{x}} = \frac{1}{k} \sum_{i=1}^k \bar{x}_i$$

and then assumed to be the estimated population mean.

In order to estimate the standard deviation of the population it is necessary to calculate the standard deviation for each sample. Because it is easier to obtain, range (R) is a preferred indicator. The range of variation of each sample (R_i) is used to calculate the mean range:

$$\bar{R} = \frac{1}{k} \sum_{i=1}^k R_i$$

The central line for the mean or \bar{x} chart is $\bar{\bar{x}}$, since it is an unbiased estimate of the population mean (\bar{x}^1). The mean range, \bar{R} , is not an unbiased estimate of the population standard deviation. But, if a normal distribution of the population is assumed, \bar{R} can be used to get an unbiased estimate of the upper control limit (UCL) and the lower control limit (LCL).

A common approach employs the "three sigma limits", i.e.,

$$\bar{x}^1 \pm \frac{3\sigma}{\sqrt{n}}$$

Then, $A_2\bar{R}$ is substituted as an unbiased estimate of $3\sigma/\sqrt{n}$ and the Constant A_2 for a given sample size is obtained from a Table of Control Chart Constants (see ASTM Manual on Quality Control of Materials, American Society for Testing and Materials, Philadelphia, Pa., 1951). Thus for the mean or \bar{x} chart:

$$\begin{aligned} \text{central line} &= \bar{\bar{x}} \\ \text{UCL} &= \bar{\bar{x}} + A_2\bar{R} \\ \text{LCL} &= \bar{\bar{x}} - A_2\bar{R} \end{aligned}$$

A similar approach is used for the range or R chart for which:

$$\begin{aligned} \text{central line} &= \bar{R} \\ \text{UCL} &= D_4\bar{R} \\ \text{LCL} &= D_3\bar{R} \end{aligned}$$

where D_4 and D_3 are constants obtained from the same Table of Control Chart Constants.

Examples of control charts follow:

ACCURACY CONTROL GRAPH FOR SUMMARY OF GAS CUTTING BY FABRICATION SHOP, HULL CONSTRUCTION WORK SHOP

QUALITY PROPERTY	CUTTING ACCURCY	MEASURED POSITION	ENDS OF PARTS	FINAL CHECKER	ENGINEER IN CHARGE	SAMPLING	FREQ.	6/DAY
MEASURED PLACE	EVERYWHERE	MEASURING PERSON	WORKER	GRAPH MAKER	STAFF OF ACCURACY CONT.		METHOD	RANDOM
MEASURING INSTRUMENT	PREScribed	ALLOWANCE LIMIT	BY ACCURACY STANDARD	INSTRUCTORS	ACCURACY CONTROLLER	JUDGEMENT	BY JUDGEMENT STANDARD	
MEASURING UNIT	0.5mm	FIRST CHECKER	ACCURACY CONTROLLER		ENGINEER IN CHARGE	CORRECTION	BY ACCURACY STANDARD	

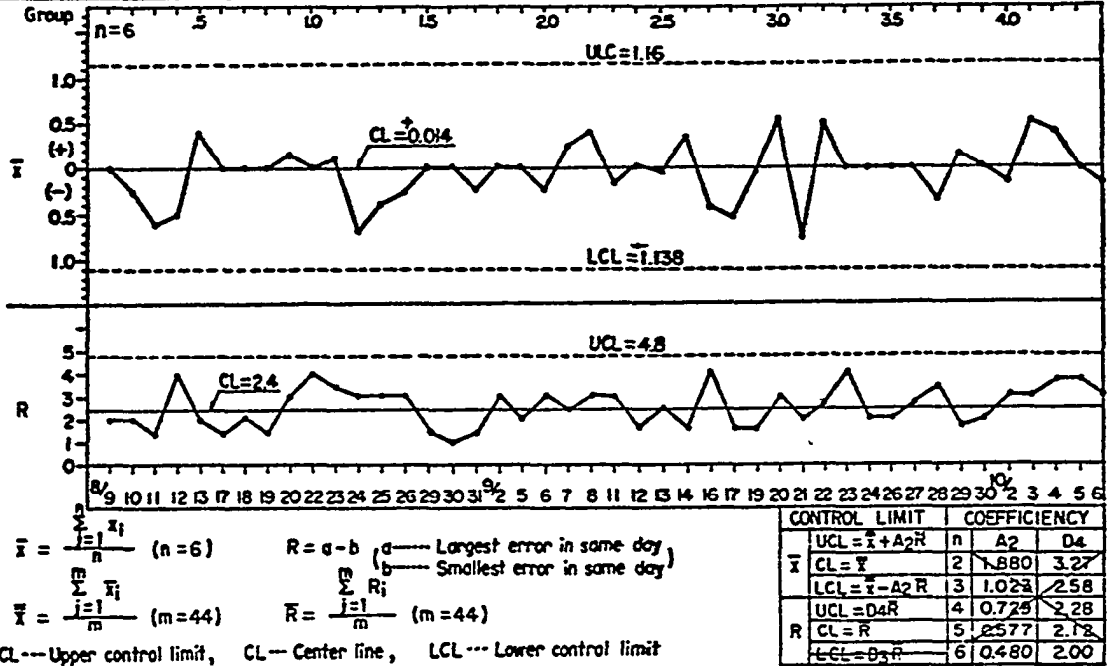

ACCURACY CONTROL GRAPH FOR GAS CUTTING OF INTERNAL STRUCTURE BY FABRICATION SHOP, HULL CONSTRUCTION WORK SHOP

QUALITY PROPERTY	INTERNAL STRUCTURE SIZES (WxL)	MEASURING POSITIONS	ENDS OF PARTS	FINAL CHECKER	FOREMAN	SAMPLING	FREQ.	6/DAY
MEASURED PLACE	5K	MEASURING PERSON	WORKER	GRAPH MAKER	STAFF OF ACCURACY CONT.		METHOD	RANDOM
MEASURING INSTRUMENT	TAPE MEASURE	ALLOWANCE LIMIT	± 1mm	INSTRUCTORS	ACCURACY CONTROLLER			
MEASURING UNIT	0.5mm	FIRST CHECKER	ASS. FOREMAN		ENGINEER IN CHARGE			

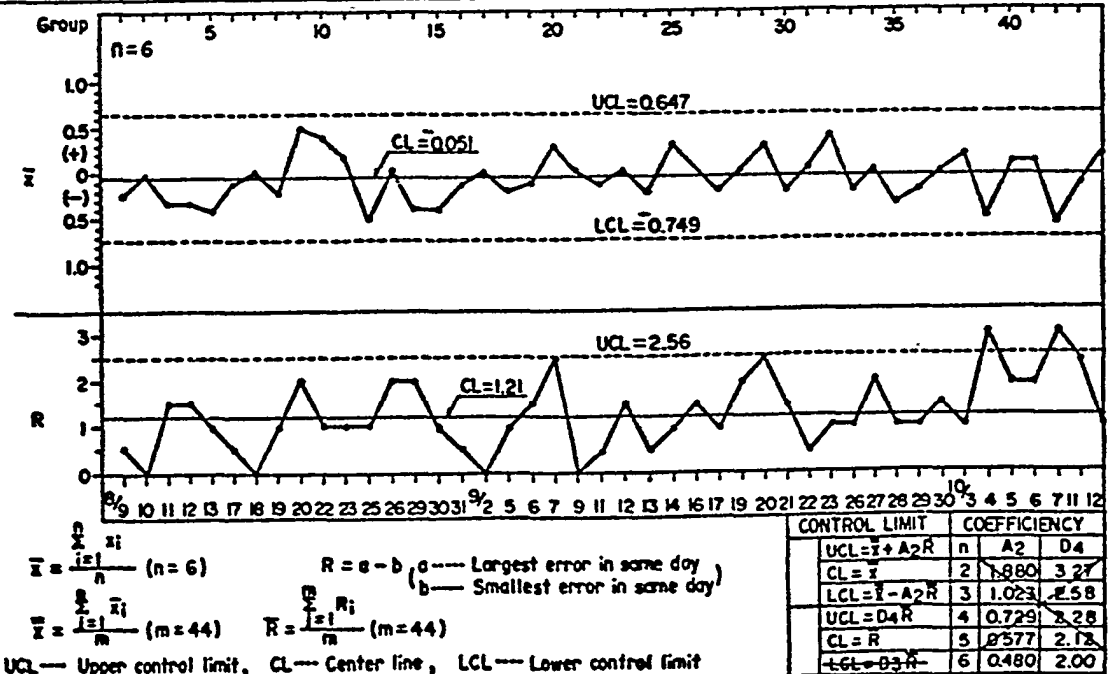

ACCURACY CONTROL GRAPH FOR ENDS SETTING OF TRANSVERSE WEBS

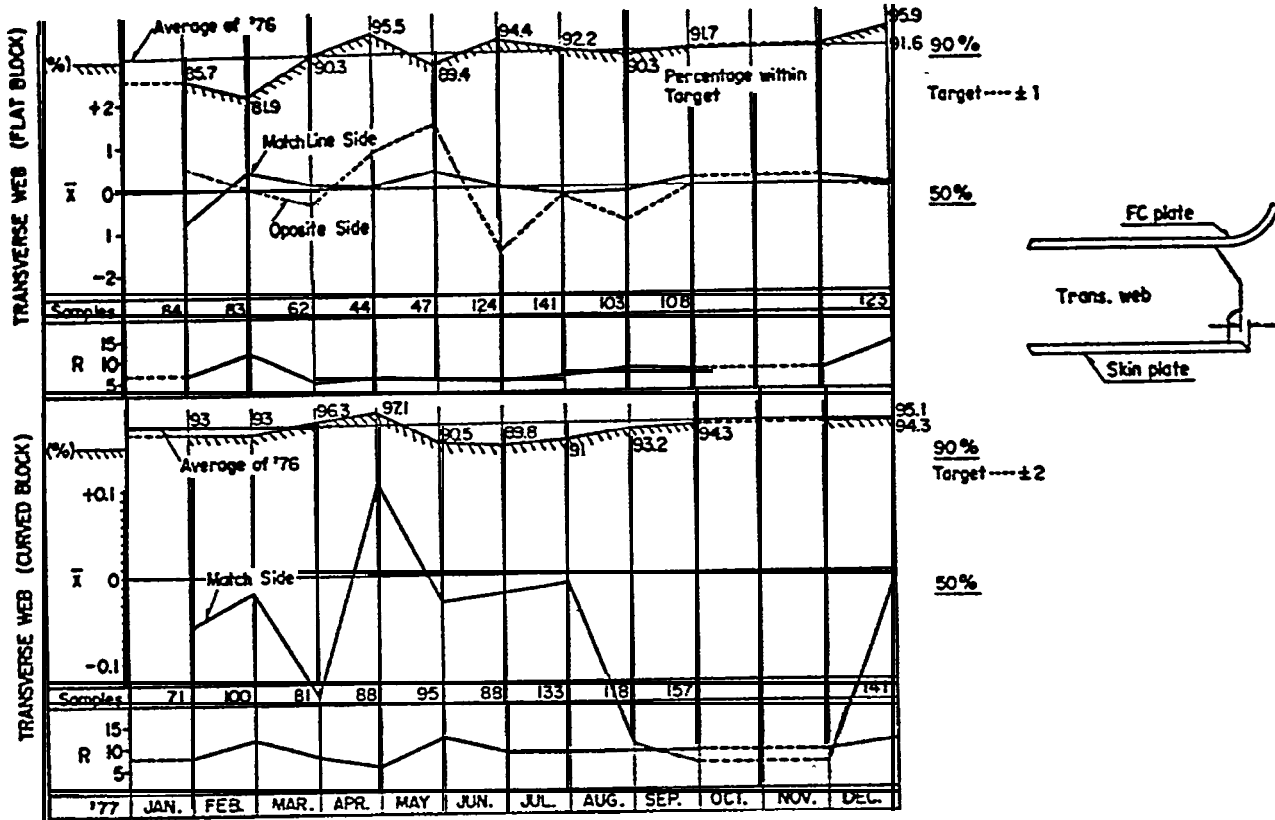

ACCURACY CONTROL GRAPH FOR ENDS SETTING OF LONGITUDINAL WEB

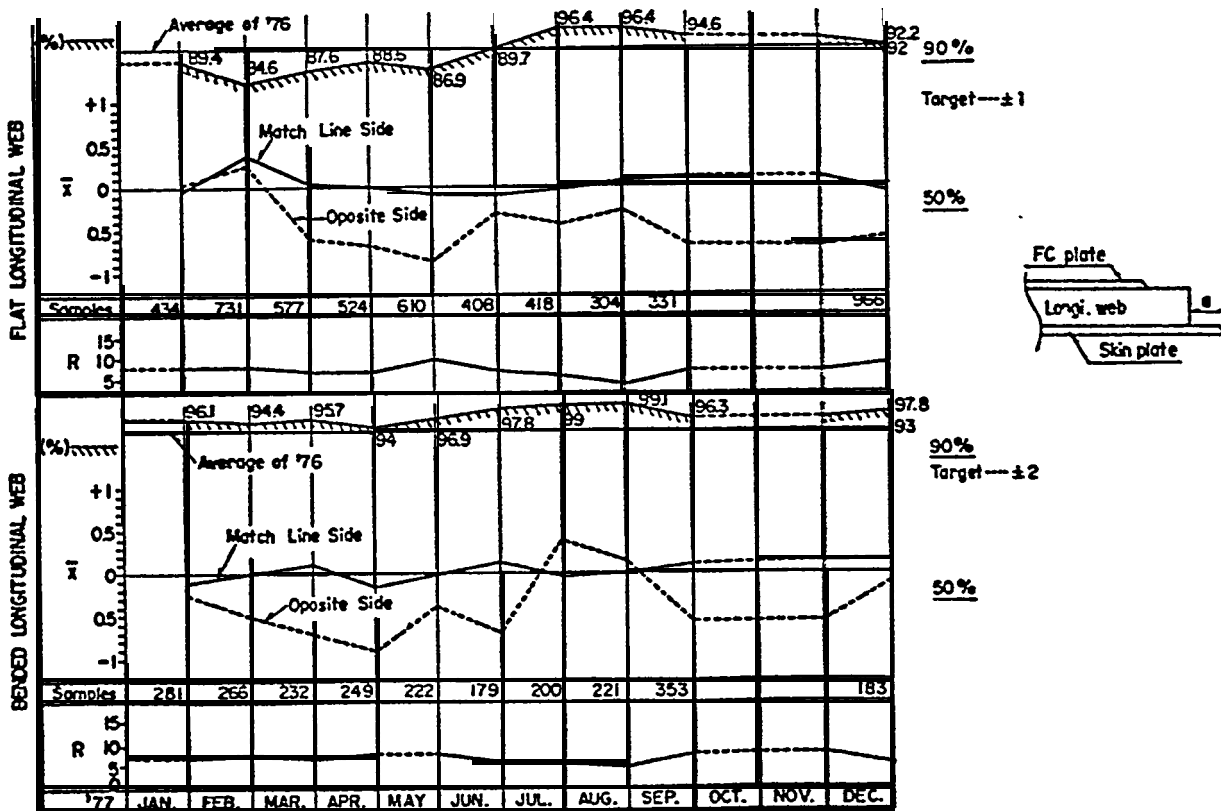

ACCURACY CONTROL GRAPH FOR MATCH LINE SETTING OF FACE PLATE AND WIDTH OF PANEL PLATE

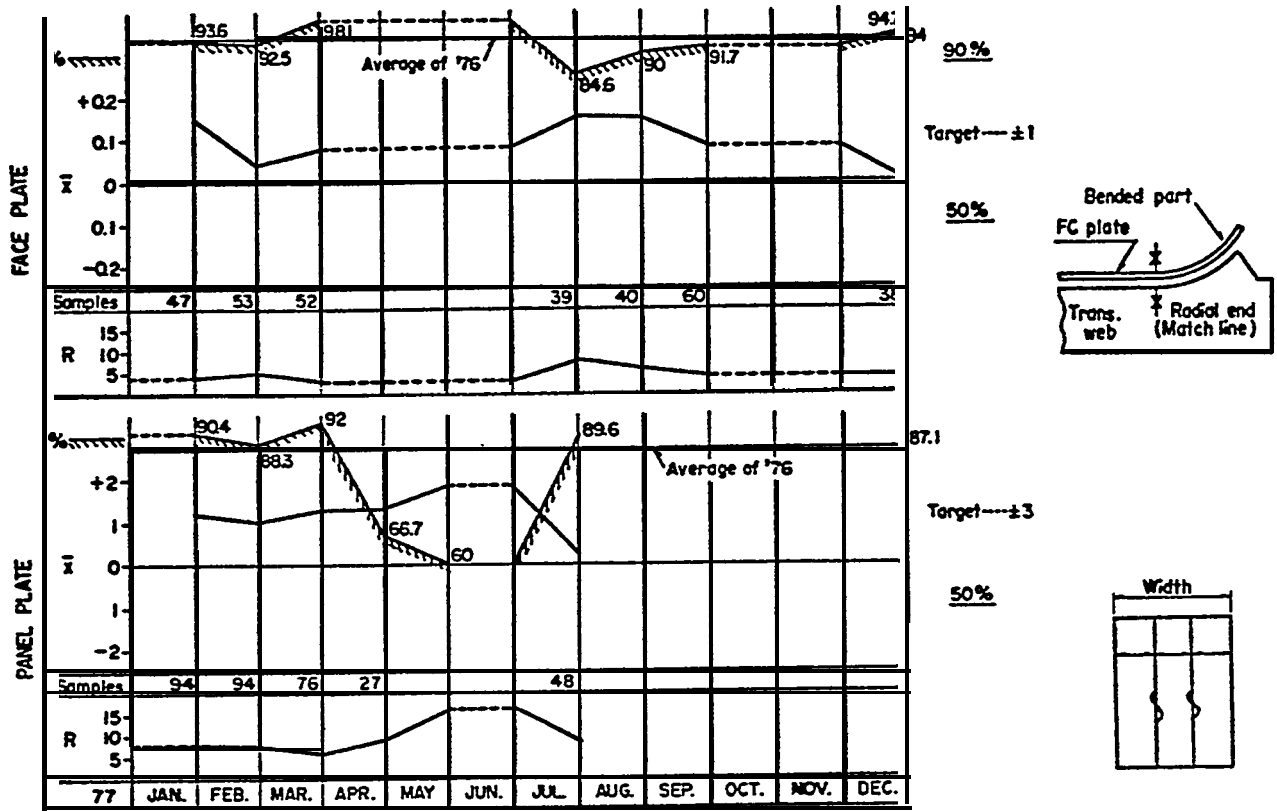

**Transportation
Research Institute**

Additional copies of this report can be obtained from the
National Shipbuilding Research and Documentation Center:

<http://www.nsnet.com/docctr/>

Documentation Center
The University of Michigan
Transportation Research Institute
Marine Systems Division
2901 Baxter Road
Ann Arbor, MI 48109-2150

Phone: 734-763-2465
Fax: 734-763-4862
E-mail: Doc.Center@umich.edu