

THE INFORMATION FLOW REQUIREMENTS OF
THE DESIGN AND PROCUREMENT PROCESSES
OF SHIPBUILDING PROGRAMS

A Project of

The National Shipbuilding Research Program

for

The Society of Naval Architects and Marine Engineers
Ship Production Committee
Design/Production Integration Panel (SP-4)

JUNE 1989

Under the Supervision of

Ingalls Shipbuilding

Report Documentation Page

Form Approved
OMB No. 0704-0188

Public reporting burden for the collection of information is estimated to average 1 hour per response, including the time for reviewing instructions, searching existing data sources, gathering and maintaining the data needed, and completing and reviewing the collection of information. Send comments regarding this burden estimate or any other aspect of this collection of information, including suggestions for reducing this burden, to Washington Headquarters Services, Directorate for Information Operations and Reports, 1215 Jefferson Davis Highway, Suite 1204, Arlington VA 22202-4302. Respondents should be aware that notwithstanding any other provision of law, no person shall be subject to a penalty for failing to comply with a collection of information if it does not display a currently valid OMB control number.

1. REPORT DATE JUN 1989		2. REPORT TYPE N/A		3. DATES COVERED -	
4. TITLE AND SUBTITLE The Information Flow Requirements of The Design and Procurement Processes of Shipbuilding Programs				5a. CONTRACT NUMBER	
				5b. GRANT NUMBER	
				5c. PROGRAM ELEMENT NUMBER	
6. AUTHOR(S)				5d. PROJECT NUMBER	
				5e. TASK NUMBER	
				5f. WORK UNIT NUMBER	
7. PERFORMING ORGANIZATION NAME(S) AND ADDRESS(ES) Naval Surface Warfare Center CD Code 2230 - Design Integration Tools Building 192 Room 128 9500 MacArthur Blvd Bethesda, MD 20817-5700				8. PERFORMING ORGANIZATION REPORT NUMBER	
9. SPONSORING/MONITORING AGENCY NAME(S) AND ADDRESS(ES)				10. SPONSOR/MONITOR'S ACRONYM(S)	
				11. SPONSOR/MONITOR'S REPORT NUMBER(S)	
12. DISTRIBUTION/AVAILABILITY STATEMENT Approved for public release, distribution unlimited					
13. SUPPLEMENTARY NOTES					
14. ABSTRACT					
15. SUBJECT TERMS					
16. SECURITY CLASSIFICATION OF:			17. LIMITATION OF ABSTRACT SAR	18. NUMBER OF PAGES 86	19a. NAME OF RESPONSIBLE PERSON
a. REPORT unclassified	b. ABSTRACT unclassified	c. THIS PAGE unclassified			

ACKNOWLEDGMENT

This is the final report of a project managed and cost shared by Newport News Shipbuilding Research Program under Maritime Administration contract DTMA91-84-C-41043. The program is a cooperative effort of the U.S. Navy, the Maritime Administration and the United States shipbuilding industry. Industry direction was provided by the Society of Naval Architects and Marine Engineers' Ship Production Committee Design/Production Integration Panel (SP-4), chaired originally by F. Baxter Barham and currently by R. K. Neilson of Newport News Shipbuilding.

Principle research was conducted by Wilkins Enterprise Inc. under a consulting contract with Ingalls Shipbuilding Division of Litton Industries, who provided data through visits and personal contacts.

I N D E X

<u>Title</u>	<u>Page No.</u>
Introduction	1-1
Background	1-1
Approach	1-2
Information Requirements	2-1
General	2-1
Information Required By The Shipyard	2-2
Types of Equipment Data	2-2
Performance Data	2-2
Configuration Data	2-3
Design Evaluation Data	2-3
ILS Data	2-3
Timing of Information Requirements	2-4
Shipyard Bid Preparation	2-4
Post Award RFG Process	2-5
Purchase Order Award	2-6
Information Required By The Vendor	2-6
Drawing Interface Information Requirements	2-7
Process Model	3-1
General	3-1
The Construction Process	3-1
General	3-1
Construction Stages	3-1
Construction Planning	3-2
During the Bidding Period	3-2
Post Award Planning Efforts	3-3
Detailed Work Planning Documents	3-3
The Drawing Development Process	3-4
System-Oriented Drawings	3-4
Arrangement and Key Structural Drawings	3-4
System Diagrams	3-4
Focus and Use	3-4
Composite (Transition Design) Drawings	3-5
General	3-5
Focus	3-6
Unit-Oriented Drawings	3-6
General	3-6
Focus	3-6
System-Type Unit Assembly Drawings	3-7
Fabrication Drawings	3-7
The Equipment Procurement Process	3-8
General	3-8
Material Procurement	3-8
Scheduling Considerations	4-1
Scheduling Requirements	4-1
Definitions	4-1

INDEX-Continued

<u>Title</u>	<u>Page No.</u>
Scheduling Considerations - Continued	
Activity Breakdown	4-2
System Diagrams	4-2
Phase One	4-2
System Design Calculations.	4-3
Phase Two	4-3
Phase Three	4-4
System Interdependencies	4-4
Equipment Procurement Process.	4-5
General	4-5
Equipment Technical Specifications.	4-5
Preparation of the RFP	4-6
Vendor Bid Preparation.	4-6
Shipyards Evaluation of Vendor Bids	4-7
Design Data Preparation	4-7
Shipyards Design Review.	4-7
Vendor Manufacturing Duration	4-7
Vendor Factory Testing.	4-8
Vendor Shipping Time.	4-8
Shipyards Equipment Preparation Time	4-8
Equipment Installation Stages	4-8
Unit Construction Process	4-9
Unit Assembly and Fabrication Drawings.	4-9
General	4-9
System-Type Unit Assembly Drawings.	4-9
System-Type Unit Fabrication Drawings.	4-9
Final System-Type Unit Assembly Planning.	4-10
System-Type Part Fabrication Planning	4-10
Part Fabrication	4-10
Unit Assembly	4-10
Scheduling Logic.....	5-1
General	5-1
System Diagram Development Process.	5-1
Unit Composite Schedule Determination	5-2
System-Type Unit Scheduling	5-2
Schedule Calculation Process	5-3
Equipment Controlled Dates..	5-4
Equipment Performance Data Path	5-4
Equipment Configuration Data Path	5-5
Equipment Hardware Delivery Path	5-5
System Interdependencies	5-6
Potential Critical Paths	5-6
General	5-6
The No Equipment Case Path.	5-7
The Equipment performance Data Path	5-7
The Equipment Configuration Data Path	5-8
The Equipment Hardware Installation Path.	5-8
Critical System Path Determination	5-9

I N D E X - Continued

<u>Title</u>	<u>Page No.</u>
Computer Program	6-1
General	6-1
Data Base	6-1
General.	6-1
Tables.	6-2
Forms.	6-2
Reports	6-2
Application Programs.	6-2
Scheduling Application program	6-2
Computer Capability Required.	6-3
Using the Scheduling Application Program	6-4
General.	6-4
Screens.	6-4
Operating Modes and Operators.	6-5
Reports	6-6
Findings and Conclusions	7-1
Informtion Flow.	7-1
Computer Program.	7-2
Summary	8-1
General.	8-1
Future Work.	8-2
Acknowledgments.	9-1
Figures	
Appendix A - Computer Program Elements.	A-1
General.	A-1
Screens.	A-1
Menu Screens.	A-1
Data Entry and Editing Screens.	A-2
Initial Data Screens	A-2
Current Data Screens	A-2
Tables	A-2
System Data Table	A-3
System-Unit Table	A-3
System-Type Unit Assembly Process Table	A-4
Unit-Stage Schedule Table	A-4
Equipment Data Table.	A-5
Equipment-Unit-Stage Table.	A-5
System Dependency Table	A-6
Schedule Status Tables.	A-6
Reports.	A-6
Schedule Reports.	A-6
Data Table Content Reports.	A-6
Computer Program Development	A-7
Calculation Programs.	A-7
Application Program	A-7
Program Code Availability	A-7
Figures	

INTRODUCTION

Background

This report describes work accomplished under a task authorized by the Ship Production Committee, Panel SP-4, Design/Production Integration.

The principle purpose of the work was to develop the tools that are necessary for integrating the schedules by which drawings are developed and equipment is procured in shipyards which use modern modular construction practices in their shipbuilding, repair or overhaul projects.

The conversion to modular construction practices from past system-oriented construction practices has greatly emphasized the need for such integrated schedules. First, there is much less overlap of the design effort and the construction effort, so there is much greater need for the drawings to be correct and complete when the drawing is first issued, without reservations caused by lack of adequate information about the equipment to be installed. Secondly, because of the emphasis on pre-outfitting of construction modules (units) while the units are being built, rather than after the hull is erected, major equipment may be required sooner relative to the shipbuilding contract award than was required in system-oriented practice.

In general it has been common in most shipyards to determine the date by which an equipment must be ordered, i.e., the equipment Purchase Order Award (POA) Date, by (a) identifying the date by which the equipment (hardware) had to be in the shipyard to support the construction process, (b) identifying the manufacturing lead time for the hardware, and subtracting (b) from (a). This approach has completely ignored the fact that equipment performance and configuration data (software) is needed to support the design Process, and is needed in a time frame which will allow drawings to be issued on a schedule which is in phase with the required construction schedules.

Since equipment cannot be ordered until the design effort reaches the point where the required performance of the equipment has been defined, and the design cannot be completed until after the equipment has been ordered and

its details are confirmed by the equipment supplier, it is clear that the drawing development and equipment procurement processes are interdependent and must be scheduled in an integrated manner.

Approach

In order to develop a system for integrating these two processes, it was first necessary to determine what information was required by each process from the other. The point of time in each process when the data was needed was also required. With these facts established, it was possible to develop the logic of the required information flow path. Finally, a computer program had to be developed to facilitate the calculations involved in the integration of the scheduling processes. This program allows the issue of reports which provide the dates which must be met.

Personnel from the Design Engineering Division of Ingalls Shipbuilding Division (ISD) and from several vendors who serve most shipyards were interviewed to develop the information requirements and the times by which various types of data had to be available for minimum interruption of their routine processes. The data from these interviews were developed into a description of the information flow paths.

Two types of minicomputer general application programs were investigated, a networking program and a relational data base program. The latter was chosen as preferable for this effort, primarily because of the greater control of the ultimate specific application program that was allowed by this approach.

INFORMATION REQUIREMENTS

General

Both the content and the timing of the availability of information are important to the generation of good schedules for the major processes which are inherent in shipbuilding programs. Information about equipment which is to be installed in the ship is as important as the equipment itself, and the lack of information can have as much influence on doing quality work on time within cost as the equipment hardware itself. The information flow process for major equipment is an iterative process, in which the shipbuilder contacts the prospective equipment vendors several times.

The first contact will be during the Pre-Bid period, when the shipbuilder is in the process of preparing his bid to design and build the ship. Using a Request for Quotation (RFQ), he will contact prospective equipment vendors for pricing data and equipment delivery lead time data, giving them such information as he has gleaned from the owner's requirements, proposed ship specifications and contract design data.

Once the successful shipbuilder has been identified, that shipbuilder will again contact potential equipment suppliers, with a Request For Proposal (RFP). The RFP will be based on further study, analysis and calculation by the shipyard, and will identify the shipyard's requirements for equipment performance, for data and for documentation.

Then, based upon review and evaluation of the technical description and other data received from the vendors, including price, the shipyard will negotiate a contract with one vendor and issue a Purchase Order (PO). This document contains a description of the technical requirements which the equipment must satisfy, the information which the vendor must supply about the equipment, and the timeframe in which the data and equipment must be provided.

Finally, for some equipment, the shipyard will issue formal authorization to the vendor to proceed with manufacture of the equipment. The "OK to Manufacture" Will not be issued until the shipyard has received, reviewed and accepted the vendor's design data and manufacturing schedule.

Information Required by The Shipyard

Types of Equipment Data

Performance Data

During the design of a ship's systems, the designer determines the need for various types of equipment and identifies the performance characteristics that each equipment must develop in order for the system to operate in accordance with all of the system requirements. These performance characteristics are then translated into the Technical Specifications for each type of equipment, which are issued with the RFQ and PO. However, the equipment that will ultimately be provided is unlikely to meet the minimum performance requirements precisely.

For instance, the system may require a pump that will provide 285 gallons per minute at a pressure of 87 psi, but the pump that is procured may be designed to provide 300 gpm at 100 psi. If the equipment that is ultimately purchased varies significantly from that which was assumed for design development, the system design may have to be modified, by addition of throttling valves, different sized relief valves, etc., in response to the actual pump characteristics. The system design cannot be considered as finished until the specific performance data of every piece of equipment in the system are known. In the worst case, the specific data about one piece of equipment could require a change to the technical requirements for other equipment that is already in the procurement process.

Performance data are needed for completion of the system diagrams, which are the drawings define the system performance characteristics. The basic system design, for which diagrams are used, does not depend heavily upon the actual configuration of the system's equipment. However, Diagrams must be finished before certain other drawings, which do depend upon configuration data, can be completed. Consequently, final performance data is needed by the shipyard for ship design process before final

configuration data is needed. The designed performance characteristics of developmental equipment are fixed by the vendor before the final configuration data are established. Thus it is both desirable and reasonable to identify a date by which the vendor must provide performance data for his equipment, one which is earlier than the date by which he must provide the configuration data.

Configuration Data

The drawings which control the ship's final configuration, and which are used for installing equipment into the ship, are dependent upon precise configuration data for all equipment being installed. These data also must be analyzed by the shipyard before it authorizes the vendor to proceed with manufacture of the equipment. The timeliness of submission of these data, then, are obviously crucial to the yard's being able to meet the construction schedule. It is vital to establish the submittal date of the vendor's configuration data contractually, but it is equally vital to ensure that the date selected will satisfy the requirements of the drawing schedule, which must meet the requirements of the construction schedule.

Design Evaluation Data

As a minimum, the shipyard must have design drawings and performance calculations of a vendor's equipment before it can give a vendor approval to proceed to manufacture. Most shipyards take this step only for major or developmental equipment, to avoid taking on an unnecessary responsibility for the performance of the vendor. In many cases, such as for switchboards or consoles, the owner will require his approval before the vendor may proceed to construction of the equipment. The PO should clearly make the vendor responsible only to the shipyard, to avoid blurring of lines of responsibility.

ILS Data

Many other types data, such as data related to Integrated Logistic Support (ILS), are needed from equipment suppliers by shipyards. In some cases the data or documents are only needed for delivery by the shipyard to the ship owner, but normally the owner will hold the shipyard responsible in some degree for the accuracy of data provided. It is very important to

the overall success of the shipbuilding program that data be separately identified, scheduled and managed. However, data such as this, which has no direct influence on the design of the ship systems (despite heavy influence on the design of the equipment in some cases) will not be further considered in this study.

Timing of Information Requirements

Shipyard Bid Preparation

At the time that a shipyard is preparing its bid for a shipbuilding program, the information needed from vendors relates primarily to cost and availability. Unfortunately, too often shipyard's request for information at this point is solely oriented toward hardware cost. Shipyards frequently complain later that they did not get enough information from a vendor, but the primary for a shipyard failing to get data is because it has failed to ask for the data.

In order to receive the most accurate cost estimate from a vendor, the shipyard must identify all of the requirements that the vendor must satisfy. Even when hardware availability is addressed in an RFQ, it is all too common for the cost and delivery data for the rest of the vendor's efforts to be overlooked or ignored. It should be obvious that the shipyard's needs for performance, configuration and ILS data, plus the time delays inherent in any review and acceptance of data by the shipyard, will result in additional costs for the vendor. The shipyard's allowance for vendor costs will be much more accurate if all of the which the vendor will have to do is identified clearly in the RFQ.

The major element shipyard's build strategy should be developed during the bidding process. Since the availability of equipment data, as well as hardware, can have a strong influence on the cost effectiveness of the overall construction approach, the information request from vendor during the pre-award effort of the shipyard must not be limited to cost data. In order to adequately develop their own work schedules and costs, the shipyard needs to obtain of the schedules by which the vendor

will be able to submit drawings, documents and other data requirements. Unless the RFQ asks for such data, the shipyard is unlikely to obtain it, and their own cost estimates will likely be too low.

The impact of the equipment data cost and availability is much greater for developmental equipment than for off-the-shelf equipment. Nevertheless, since the shipyard needs the most accurate possible cost quote from the vendor, it follows that the yard must identify all the work which is expected from the vendor and upon which the vendor must quote, for all equipment, even at this first stage of information exchange.

Post Award RFQ Process

The RFQ contains the Technical Specifications, prepared by the Design Engineering organization, and additional contractual provisions developed by the Purchasing Department. The technical specifications establish the minimum technical requirements that must be met by the equipment to be furnished. In addition, the RFQ should include a complete description of each of the data deliverables that the vendor will have to provide. The dates by which each type of data are to be needed in the yard must be established by the shipyard at this time. The vendors must be required to specify that they will meet the time requirements for data submission or identify the date by which they will provide the data, with clear justification for not being able to meet the shipyard's desired dates.

With respect to hardware schedules, the shipyard must provide prospective vendors with as much information about specific in-yard delivery dates possible. Not all items of identical equipment are needed in the yard on the same date, so it is appropriate to identify separate dates for each item, rather than require all items to be delivered on the date when the first item is needed. If the equipment supplier's production rate cannot satisfy the rate by which equipment will be installed, then the supplier will have to provide the shipyard with proof that the required shipyard delivery schedule can be met.

If the RFQ requires that the vendor furnish a complete description of the equipment offered, including the equipment's performance data as well as its configuration data, process of selecting the successful vendor will be greatly simplified and the design process will proceed with fewer reservations and fewer changes, all of which will save manhours and time.

Purchase Order Award

The Purchase Order (PO) is the document to which the selected vendor must actually perform. Consequently, it must be as definitive as possible. Vague statements of requirements by the shipyard are appropriate only where the shipyard can accept any possible interpretation of the requirements by the vendor. The shipyard and the vendor must agree on the delivery dates of performance data for the equipment, including noise characteristics, acceptable vibration levels, maintenance requirements proposed spare parts requirements, test data, technical manuals etc., and the PO must reflect those agreements in detail. The required content of the configuration data must be defined the, as well as the date by which it must be provided.

It is common practice in some shipyards identify a single date for delivery of all data. However, since the designed performance data of an equipment is available in most cases before the final configuration data is developed by the vendor, and since the performance data is needed by the shipyard before the configuration data, separate dates should be established for submitting each type of data should be specified in the PO.

Information Required by the Vendor

Vendors need to know what the shipyard wants. The requirements must be stated clearly and definitively. Performance requirements must be stated in terms of criteria that can be measured and demonstrated. Maxima, minima or ranges of satisfactory performance should be identified. All data that the shipyard wants the vendor to provide must be identified as clearly as possible. Examples of satisfactory submittals, or standardized data input sheets should be provided whenever possible.

Among other things vendors need a clear description of:

- a) the performance parameters that their equipment must satisfy,
- b) the environmental conditions under which their equipment must operate successfully,
- c) all data and documents that must be submitted,
- d) the required (desired) schedule for data submittal,
- e) any physical dimensional limitations which their equipment must operate within,
- f) any training that must be provided by vendor,
- g) any criteria that will have to be satisfied in order to receive approval to proceed to manufacture,
- h) what vendor testing or other requirements must be satisfied for acceptance of the equipment,
- i) the required (desired) schedule for hardware delivery.

A Common complaint of vendors is that they are not given sufficient information about the confines within which their equipment is expected to work. Environmental conditions are normally described, but, particularly when a vendor is made responsible for installation of much or all of a system, the design of the compartments in which the equipment is to be installed must be made available to the vendor before his manufacturing process begins.

Drawing Interface Information Requirements

In addition to equipment information, system designers frequently must make assumption and feedback concerning their system's interfaces with other systems. For example, a salt water system may provide cooling water for another system. The requirements of the user system must be known before the requirements of the system which provide the service, the provider system, can be determined. In general, this too is an interactive process. The user systems requirements are first provided by its designer to the provider system's designer as an estimate and then confirmed as its equipment data becomes firmly known. The user system's estimated needs are used in the provider system's designs, but the provider system design cannot be considered complete until the systems' designs are complete. Thus, the re-

quired completion date for the user system - and consequently the
submittal dates for user system equipment data - may be controlled by the need
to give data to the provider system in time to meet the provider system's
schedule constraints.

PROCESS MODEL

General

In order to develop an integrated schedule for a complicated process, it is necessary to identify all of the activities which must take place during the process, identify the length of time necessary to carry out each of the activities (the activity "duration"), and then to identify the interrelationships between activities. When the process is complex, it is helpful to first group some activities into broader classifications, if possible.

In developing a "model" of all of the activities which must take place during the shipbuilding process to develop drawings and procure equipment, and of their interrelationships, it was helpful to first identify certain families of activities which occur. Figure 1 is a simplified version of the model, which illustrates the several types of activities involved. These types can be further combined into three basic processes, the Drawing Development process, the Equipment Procurement process and the Construction process. Each of the three processes are defined in Figure 1 by the bold lines which surround them.

The Construction Process

General

Since the Construction process is the most labor intensive effort of any shipbuilding program, the planning of this process is the most essential aspect of minimizing shipbuilding cost. All other schedules must be built to phase in effectively with the ship construction schedule. Because of the driving significance of the Construction process, a quick description is appropriate as background for more detailed descriptions of the Drawing Development and the Equipment Procurement processes.

Construction Stages

The various types of effort involved in the Construction process are identified in Figure 1 within a bold line. In modern modular shipbuilding practice, ships are constructed by units, which are then combined, or erected,

to form the ship . All planning of how various parts of systems and equipment are to be installed and assembled is done on a unit by unit basis. Parts of each system are usually fabricated by rather than by system, in time to support the assembly or outfitting of the unit.

Thus, the scheduling of the assembly and outfitting process for each unit becomes the controlling factor for the scheduling of the drawing process and may control the scheduling of Equipment as well.

One shipyard had identified the several different stages of the assembly and outfitting process as follows:

- Stage 20 - Structural Panel Assembly
- Stage 30 - Assembly Structural Panels into Unit
- Stage 40- Machinery Package unit assembly and Outfitting
- Stage 50 - Preblast On-Unit Outfitting
- Stage 60 - postblast On-Unit Outfitting
- Stage 65 - Join Unit into Block and Outfit Block
- Stage 70 - Erect Blockin Hull
- Stage 80 - Onboard Outfitting

These definitions will be used for this report. Each stage, except stage 40, is sequential. Stage 40's construction normally proceed in parallel with some other construction stages because machinery package units may be installed during any one of the other stages, suchh as stage 50, 60, 65, 70 or 80. To be ready for installation in stage 50, it will have to be assembled in parallel with the work in stage 20 and/or 30.

Construction Planning

During the Bidding Period

Although not indicated Figure 1, construction planning efforts start during the shipyard's preparation of the bid for the shipbuilding contract. A "Build Strategy" must be developed as part of the effort estimate the cost of building the ship(s). This entails the initial definition of how the ship will be broken down into units, how many construction

stages will be used to build each unit, a schedule for each stage of each unit and the locations within the shipyard where each stage of each unit will be assembled.

Post Award Planning Efforts

After award of the shipbuilding contract, the shipyard will make a more detailed study of the plan which was prepared during the bid process and proceed to more detailed planning of all of the steps which will have to be performed during each construction stage of every unit. This planning is done with input from the design engineering and purchasing departments so that their planning efforts will mesh with the construction planning. The other major reason for coordination of these planning efforts is to preclude unrealistic assumptions about when drawings and equipment will be available to support the Construction process.

All of the Assembly and Fabrication drawings (defined later) prepared by the Design Engineering Department must be developed so that the work can be accomplished as planned by the Industrial Engineers in the Production organization. The Composite Drawings must be developed to correspond with the construction sequence, in order to be most useful in guiding the development of the final Assembly Drawings. Since these drawing products are prerequisites for actual ship construction work to begin, it is clear that the construction planning efforts described above must start immediately after contract award, and must be finished as quickly as possible.

Detailed Work Planning Documents

A final stage of production planning takes place after the assembly and fabrication drawings are produced. The final work orders to individual construction trades, which describe specific activities of work to be accomplished, based on the actual content of the drawings, and which contain manhour allowances for each trade, can only be prepared after the drawings are in hand. Final fabrication planning, including detailed shop routing of individual pieces described on the drawings, must be allowed for in the overall scheduling process. Only these final planning efforts are included in Figure 1.

The Drawing Development Process

Several of the elements shown in Figure 1 involve the development of different types of drawings. Each of these is considered as a different family of activities and will be discussed separately.

System-Oriented Drawings

Arrangement and Key Structural Drawings

The first drawings that need to be developed are the space arrangement drawings, key structural drawings and major machinery foundation drawings. These drawings establish the overall background for developing and defining the structure, detailing the configuration of individual distributed systems, and for locating equipment. Initial completion of at least some of these drawings is a prerequisite for beginning the system diagram effort. The drawings will not be considered finally complete until they reflect any changes found to be necessary during later design stage developments.

System Diagrams

The development of system diagrams is the next stage in the Design Development process. These drawings provide a complete description of the requirements for each system in the ship, including structural systems, piping systems, ventilation systems, electrical and electronic systems. With respect to scheduling, this stage in the process is crucial because it controls the procurement of most equipment and material, in addition to defining all individual system requirements, and thus controlling the development of all the drawings from which the ship is constructed.

Focus and Use

The types of drawings mentioned above are primarily system oriented, in that they establish the arrangement and the requirements which must be met by all elements of every system on the ship. One of the prime uses of these drawings is to describe to the ship's owner and to regulatory bodies how their requirements will be satisfied. In fact, drawings similar to these normally will have been made available by the owner to the shipyard (in US shipbuilding practice) as guidance during the bid process and again as part of the contract design package. However, the shipbuilder must redevelop these drawings for their own use, doing all the calculations necessary to prove the

systems' adequacy to meet the specifications. Thus, in developing these documents, the shipyard designer's focus is largely oriented to meeting requirements imposed by organizations outside the shipyard or demonstrating that those requirements have been satisfied. However, these drawings also establish the baseline for the designers of other types of shipyard drawings, since all of the drawing products which follow in the overall Drawing Development process must fully satisfy the features defined in the system drawings.

Composite (Transition Design) Drawings

General

After individual systems are defined in system diagrams, their features normally are combined into composite drawings, which show where all systems in a ship's spaces are located. In a number of shipyards today, this is done by creating a computer model of the ship's systems. In recent years, this stage of the design process has been labeled by some as the "Transition" design stage, since it represents a transition from the system-oriented drawing stages just described to the modular-oriented drawing stages which follow this stage.

Composites can be started as soon as some arrangement and key structural drawings are sufficiently complete to define the geography of the area, but no part of a composite can be considered complete until every part of each system located in that area of the ship has been completely defined. Until the diagram is complete (accurately describes every system requirement and every non-stock system element), it is impossible for the composite drawing to be completed in any area through which that system passes. Similarly, it cannot be complete until a complete description of every piece of equipment in that area is available.

Modern modular ship construction practices involve breaking the ship down into units, each of which is planned and built as a separate entity, then joined with other construction units to make up the ship. Thus, the overall composite drawing can be considered to be the sum of composite drawings of each unit. It is most useful to schedule the composite drawing for completion unit by unit.

Focus

Composite drawings are a tool used by the shipyard design organization to design in detail the layout of all the systems in the different compartments. They are the principal technique used to eliminate interferences between the routing of individual systems. The focus of the designers is no longer directed toward meeting the requirements of outside forces, but toward integrating the individual systems into an effective cohesive whole, capable of being constructed in a logical manner. Composite drawings tend to become very complicated because they show every part of every system in each compartment. Because they are so complicated, and are not well suited to the needs of the construction personnel, they are not normally issued to anyone outside the design organization.

Unit-oriented Drawings

General

The next stage in the Drawing Development process is the development of drawings which can be used efficiently by shipyard construction personnel. Assembly drawings provide the details of how every part of every system is to be installed in the ship. Fabrication drawings show how the individual parts of systems are to be manufactured. For shipyards using modular construction techniques, these drawings relate to a unit or block (a combination of two or more units), since those are the basic elements from which the ship is assembled. They no longer relate to systems. Only those portions of a system which exist in a unit will be shown in the unit-oriented drawings.

Focus

These drawings are prepared to provide construction workers with guidance during the construction and assembly of all the parts which make up the ship. As such, their focus is entirely upon the production processes which will be carried out in the building yard. Since the construction labor force is broken down into trades, each of which requires experience in those skills which relate to certain processes or certain products, the Assembly and Fabrication drawings are normally trade-related, as well. The drawings are prepared to communicate with the production workers and describe what work must be done to make and assemble various parts of systems into the unit, and ultimately into the ship.

System Type Unit Assembly Drawings

Assembly drawings, as the name implies, provide data relating to how parts are to be assembled. Dimensional information and other details of assembly are provided. A number of assembly drawings are usually produced for a unit, each showing the assembly data for a different Type of system, such as structure, piping, ventilation, wireways, etc., since a different construction trade would be involved in the assembly of each different system type. Thus, assembly drawings are primarily oriented toward the work skills which are involved in assembling the type of system involved in one unit.

Frequently, the parts for one system type may be installed at several stages of a unit's construction. Specifically, structural parts may be installed in Stages 40, 50, 60 or even later, as well as in Stages 20 and 30. Likewise, piping parts will probably be installed in several construction stages. It is quite common to develop separate drawings for each stage of construction for each system type. Another approach used in some shipyards is to place information pertaining to separate construction stages on separate sheets of one drawing. From a scheduling standpoint, however, the only stage that matters is the first in which a system type will be installed, because the entire system layout must be completed before the first, even partial, installation.

Fabrication Drawings

Fabrication drawings are the final type of drawings developed for shipbuilding programs. They describe how to make any part that is to be manufactured within the shipyard. These are the final products of the Drawing Development process and provide the necessary data for the start of the Construction process. Like Assembly Drawings, Fabrication drawings for modular ship construction programs are prepared by system type by unit, and not by system.

The Equipment Procurement Process

General

The purchasing of equipment for a ship is recognized by all shipyards as a critical element of delivering a completed ship on time. Thus, it is common, and normally required by the shipbuilding contract, for the shipyard to develop a list of major equipment, to identify milestone dates for the purchase and delivery of each item on the list and to track the status of completion toward each milestone date. Of the many activities which make up the procurement process for each equipment, the four which control the integration of schedules are the preparation of the Technical Specifications for the equipment, the preparation by the equipment vendor of Performance Data and Configuration Data relative to the equipment, and the manufacture of the equipment. Each of these will be described in detail in the next Chapter.

Material Procurement

In addition to specific pieces and types of equipment, many types of material, such as steel, piping, electrical wiring, fasteners, welding rod, etc., must be procured for each ship. Material is of two types, that which is carried in the shipyard's warehouses as stock material and that which is specially procured for a specific program.

Stock material is normally ordered on a demand basis, based on the past experience concerning usage rates and satisfactory reorder levels.

Special order material normally is bought based upon the material lists in system diagrams, with some effort made to consolidate requirements from several systems whenever possible. Past experiences with the timeliness of delivery of each type of material will strongly influence a yard's practices in this regard. Special precautions are necessary to ensure that materials ordered for a specific program are stored and marked in a manner that facilitates their location and identification when they are needed.

No effort has been made in the present study to develop ordering schedules for material. Where it is considered necessary to precisely manage the procurement of some type of special order material, the material can be treated as an equipment in each diagram in which it is located, and the required dates for procurement will be generated by the program provided.

SCHEDULING CONSIDERATIONS

Scheduling Requirements

To develop an integrated schedule, having identified the major processes which must be taken into account, it is then necessary to identify each of the significant component activities which must be scheduled, estimate the overall duration of each of them and define the controlling date(s) of the combined process. Finally, it is necessary to identify the interrelationships between each of the activities under consideration.

For the purposes of this study, only certain elements of the three major processes discussed in the previous chapter need to be considered in detail. These are the System Diagram Process, the Composite Drawing Process, the Equipment Procurement Process and the Unit Construction Process. The Unit Construction Process is a combination which integrates the development of Unit Assembly and Fabrication Drawings of each system type with the Planning efforts for Assembly and Fabrication and with the actual Fabrication and Assembly processes. These must be tied into the schedule for construction of the stages of each unit.

Definitions

The commonly used definitions for developing scheduling networks are as follows:

Activity - A portion of work which can be separately identified from other portions of work, by its having a discrete starting date and a discrete finish date and by having specific requirements for expenditure of resources. These resources normally include personnel of at least one trade skill and frequently include equipment or material.

Duration - The length of time between the start and finish date of an activity.

Activity Interrelationships - In any process there are some activities which cannot be started before at least one other activity has finished. In such cases there is said to be a "finish-to-start" (FS) relationship. In other cases, one activity may not be able to be finished until another activity has been finished, establishing a "finish-to-finish" (FF) relationship. Finally, there are cases where a "start-to-start" (SS) relationship exists.

Lag Time - In each of these types of interrelationships, there is likely to be a time lag between them. For example, if drawing A cannot be completed until drawing B is completed, some time must be allowed for the designer of drawing A, the dependent drawing, to obtain and review the completed drawing B and to incorporate any new information into his own drawing. Thus it is always necessary to identify a "Lag" with every FS, SS or FF relationship of two activities, even if, as for many FS cases, the value is 0.

Activity Breakdown

System Diagrams

The activities which make up the System Diagram process are illustrated in Figure 2A and described below.

Phase One - The initial phase of preparing a diagram involves reading and becoming familiar with all of the system requirements stated in the contract specifications, contract drawings and other contract documentation, such as Annexes describing Logistic Support requirements, Quality Assurance requirements, etc. It includes obtaining structural drawings and arrangement drawings, preparing the diagram background, doing an initial system routing, identifying all major equipment required for proper operation of the system and obtaining as much information about the quantitative requirements of other systems which must be provided with services from the system being designed. The material requirements of the various elements of the system are established in phase one. This phase, then, involves the accomplishment of all tasks which must be done before system calculations can be started.

System Design Calculations - The effort to complete a system diagram involves doing calculations to define the performance requirements for every element of the system. These calculations will be considered, in this study, to be a constituent element of the diagram development process.

For the purposes of this project, it is assumed that calculations do not start until after Phase one of the diagram effort is complete, and that neither Phase two or the Equipment Technical Specifications will be started until the calculation effort is complete. In actual practice, it is not uncommon for the calculations, the diagram and the technical specifications each to be done by individual engineers or engineering groups, and, in any case, to overlap. However, that approach requires each design group to make numerous initial assumptions, each of which must be verified through continual, iterative, information exchanges with other groups. That approach is not necessarily the most efficient. It could reduce the overall duration of the combined effort, but it would require greater manhour expenditures. Consequently, the process model shown in Figure 2A, which assumes that each step of the process will proceed in series, rather than in parallel, and which is considered to describe the most efficient approach for developing the diagram schedule, has been used for this project.

Phase Two - After the calculations are completed, it is then necessary to add to the diagram the dimensions of piping, ducting or other constituent elements of the system which have been determined by the calculations. Other performance data, such as required pump capacity curves, may be added. Although this phase requires feedback of actual performance data of vendor equipment before it can be considered truly completed, it is common to make preliminary issues of the diagram before all such data is available. These preliminary issues are provided to the designers of other interdependent systems, to keep them familiar with the data which is available.

Significantly, as indicated in Figure 2A, the preliminary issues also are sent for approval to a number of other places. The ship's owners normally require submittal of all drawings for their review, and a number of

regulatory bodies, such as the US Coast Guard, the Insuring activity and the US Public Health Service, must give approval to the content of designated drawings before construction of the ship can be started without risk.

For the purposes of this study, formal completion of phase two is contingent upon having received final equipment performance data from the vendor of every equipment in the system and having updated the diagram to reflect that data. It will be assumed that the time necessary to receive this data will have been sufficient to obtain all necessary drawing approvals, as well. In practice this is normally so. When it is not so, it is normal for the shipbuilder to proceed with the remainder of the design effort anyway, assuming that the drawing content will be approved, rather than hold up work until response is received from the reviewers.

The completion of this phase of the diagram effort is a prerequisite to the completion of the Composite drawing of any part of the ship through which the system passes.

Phase Three - This phase is identified separately from phase two to recognize that there are data which are included in diagrams that may not be known until after the vendor performance data is available, and which do not control the completion of the composite drawing. Such data include certain equipment related data that support ILS requirements, etc. Phase three must be completed before the diagram can be considered ready for final issue to the customer.

A period for review and response by the owner should be included in any formal listing of drawing activities, and has been shown in Figure 2A. However, this stage of approval will have no significant effect on the shipbuilding schedule.

System Interdependencies

The vast majority of systems in a ship interrelate directly with at least one other system. For example, cooling water and electrical power must be provided to HVAC systems. Each such interrelationship involves a demand of one system for service of some kind from the other system. The user

system's quantitative requirements for service must be known before the provider system's design can be completed. For scheduling purposes, then, the provider system's calculations cannot be completed until after the calculations of the user system are finished. Conversely, this means that the completion date of the user system must satisfy the completion date requirements of the provider system.

The actual degree of system interdependencies in a ship design is so great that attempts to model the process in enough detail to include all the iterations that actually occur have inevitably failed because they become too complex. Thus, in this project, iterations have been ignored. Each system will be scheduled to complete in time to meet the needs of the most demanding schedule of its provider systems. This approach has been found to provide good, usable, realistic schedules.

Equipment Procurement Process

General

Figure 2B illustrates the activities, and major milestones of the Equipment Procurement process, as well as the interrelationships between the various activities. This process occurs for each item of equipment that is procured. When multiple pieces of the same item of equipment are bought, all activities up to the manufacturing activity are common to all items of that equipment, but it is possible to identify specific schedules for each item of equipment from that point on, depending on the required installation date of the individual item.

The activities identified in Figure 2B are sufficient to cover the requirements for developmental equipment. Some of the activities shown would not necessarily be required for off-the-shelf equipment. Provision has been made in the database for entering the duration of each of these activities for each equipment of the ship.

Equipment Technical Specifications

Equipment procurement cannot logically proceed without the required performance characteristics of the equipment having been established. These requirements are stated in the Equipment Technical specifications. The

Technical Specifications are included in Requests for Proposal (RFPs) and in the Purchase Orders (POs). Technical specifications cannot be developed without completion of the diagram calculations, since the calculations define the performance parameters of the equipment. Thus, the technical specifications, prepared by the Design Engineering Department of the shipyard, not only represent the initial step in the equipment procurement process, but also represent the critical link between the Drawing Development process and the Equipment Procurement process.

The preparation of equipment technical specifications may start any time after the system calculations have been completed. The duration of this activity will vary considerably, depending upon the availability of technical specifications which have been used in the past to obtain the same or similar equipment.

Preparation of the RFP

In addition to the technical specifications, an RFP must contain many administrative and other requirements. Much of this type of information is repeated in every RFP ("boilerplate") but other parts of an RFP may be tailored to the specific procurement. Much of this work is accomplished by the Purchasing Department without Design Engineering input and can be done in parallel with the development of the technical specifications. Thus, the duration of the development of those parts of the RFP other than the technical specification is independent of the technical specification preparation duration, but the RFP cannot be finished and issued until the technical specification has been received and incorporated. Although the finish-to-finish lag between the specification completion date and the RFP issue date could be set to a constant value, such as two weeks, the program provided herein allows this lag to be identified uniquely for every equipment.

Vendor Bid Preparation

Equipment vendors are given a fixed time by which they must submit their bids in response to the RFP. Some shipyards use a single duration for this activity, such as 45 days. For this project, a different duration, in weeks, may be entered for each equipment included in the database.

Shipyard Evaluation of Vendor Bids

Time must be allowed in the Equipment Procurement Schedule for evaluation by the shipyard of the bids received from competing vendors. Bids are evaluated from technical, schedule and cost considerations. The conclusion of this activity is the Purchase Order Award Date, a major milestone.

Design Data Preparation

Various types of data concerning equipment are needed by the shipyard, some for its own use and some for transmittal to the ship owners for use after delivery. The two types of equipment data which are of most concern to the shipyard's design effort are Performance Data and Configuration Data, as previously discussed. As shown in Figure 2B, the submittal dates of these two types of data should be separately identified, scheduled and monitored.

Shipyard Design Review.

A period of time must be allowed for evaluating the vendor's design. At the end of this activity, the shipyard formally authorizes the vendor to manufacture the equipment as designed. The owner may require that the shipyard submit the design data of certain specific major equipment to them for review and approval before authorizing a vendor to proceed with manufacture. This has the potential for significant delays, and for major disruption in a shipbuilding program, so it is important to provide ample time in the schedule for this activity for such pieces of equipment. Control consoles and switchboards are examples of equipments which have occasionally been problems in this regard.

Vendor Manufacturing Duration

The time necessary for the vendor to provide a specific piece of equipment will depend upon his production rate and prior orders. If an item of equipment is manufactured in large enough quantities, the vendor may have items in stock, so that the "manufacturing duration" would be 0. At the other extreme are developmental items of equipment, for which the supplier has no ongoing production line and for which the accuracy of the vendor's quoted manufacturing duration may be questionable. Thus, determining an accurate value for the duration of this activity must be a matter of high priority in the scheduling process.

Care must be taken to ensure that the manufacturer's equipment delivery rate will match the required construction schedule installation rate, particularly for multi-ship construction programs. Ideally, the shipyard should provide the vendor with the in-yard need date for each item of equipment required. The computer program developed during this study effort provides the shipyard with that information.

Vendor Factory Testing

This activity could be included within the Manufacturing Process, but has been separately identified herein in order to allow a separate schedule report of vendor factory testing to be developed. Such a schedule is helpful when the shipyard design personnel and/or customer representatives must attend the factory tests.

Vendor Shipping Time

This activity is identified separately to underscore the importance of knowing the planned or required arrival date in the shipyard, as opposed to the shipping date from the vendor's plant.

Shipyard Equipment Preparation Time

An allowance must be made for inspection and pre-installation work on equipment after arrival at the shipyard. Although "just-in-time" deliveries of equipment represent perfect planning, they are seldom planned in US shipbuilding programs because of past non-perfect delivery performance of equipment vendors. Thus this activity includes any allowance for warehousing or storage before installation.

Equipment Installation Stages

Many items of equipment are needed in quantities of more than one. In most cases, some or all of the items will be installed in compartments and/or units separate from the others. It is necessary, therefore, to identify each unit in which one or more of item of an equipment will be installed, and then to identify, for each of those units, the construction stage during which the equipment will be installed. These data will be used to identify

the earliest required equipment installation date, which may control the Purchase Order Award date, and also will be used to provide the in-yard need dates for each item of equipment.

Unit Construction Process

Unit Assembly and Fabrication Drawings

General

As previously stated, there normally will be several different assembly and fabrication drawings prepared, by system type, for each construction unit. Each of these must be scheduled so that the parts to be fabricated will be available in time to be installed during the appropriate stage of that unit's construction. Figure 3A shows all of the component activities for the Unit Drawing, Planning and Construction Processes for one system type, such as piping systems, and how they interrelate. A more detailed description of each of these activities follows.

System Type Unit Assembly Drawings

Although it is possible to start a unit assembly drawing before the composite drawing for that unit has been completed, this has a high probability of involving more design manhours due to having to make changes as the composite changes. It also introduces the possibility of errors due to not having picked up some changes. Therefore, for the purposes of schedule development in this project, the start of the System Type Unit Assembly process will be made dependent upon completion of the Unit Composite Drawing process. On the other hand, completion of the assembly drawings will be made dependent upon the completion of the fabrication drawing, to ensure that any needed changes found during the development of the fabrication drawings will be included in the assembly drawing.

System Type Unit Fabrication Drawings

Sometime after the start of the Unit Assembly drawing, when enough details of the system have been determined, the part fabrication drawing(s) may be started. The SS lag between the start of the Unit Assembly Drawing and the start of the part fabrication drawing is a variable which is

to be entered into the database. The FF lag from the completion of the fabrication drawing to the completion of the assembly drawing also must be entered.

Final System Type Unit Assembly Planning

Following the completion of the assembly drawing and a two week lag time for reproducing and distributing the drawing to the Production Planners, a period of time must be allowed for preparation of specific work instructions.

System Type Part Fabrication Planning

After receipt of the fabrication drawing by Production and Shop Planners, the schedule must allow time for planning the final shop work sequencing and material ordering. Material ordering here means drawing material from shipyard storage or other immediately available storage, not initial material ordering. A two week lag has been assumed between drawing completion and start of fabrication planning.

Part Fabrication

The period of actually fabricating the parts will follow the planning period. Again, a two week FS lag time has been assumed for scheduling purposes.

Unit Assembly

Although parts from one system type may be installed during different construction stages, the controlling stage, from a scheduling standpoint, is the first stage into which parts of the system type are to be installed. Since the first stage of assembly of any unit is the structural assembly stage, the structural parts fabrication process must complete in time to support the start date of Stage 20 of the unit.

The parts fabrication process for other system types will have to complete in time for the parts to be ready to be installed in whatever stage has the earliest start date for installation of parts from that system type. In many cases this will be the pre-paint outfitting stage, stage 50, but in others it will be the machinery unit stage, stage 40. The initial installa-

tion of still other systems may not be scheduled until after the unit has been blasted and painted. Figure 3B illustrates some of the different possible variations.

SCHEDULING LOGIC

General

In developing a scheduling logic it is possible to start from either the beginning or the end of the process and work toward the other end. In practice, it usually is necessary to do both in order to establish the early and late dates for each activity.

For the current study it was most useful to look at the scheduling process for a single, independent system, such as a piping system. The system diagram process, and specifically the completion of the system calculations, controls the completion of all subsequent events. Consequently, to ensure that subsequent events occur when they must, it is crucial to know the date by which the system calculations must complete. There are several paths of events which follow the completion of the system calculations, any one of which might be the critical path for that system.

It also is necessary to look at the scheduling process from the unit construction scheduling standpoint, since all drawing development and equipment procurement must support the construction schedule.

System Diagram Development Process

As shown in Figure 2A, once the system calculations are complete, it is possible to proceed with Phase Two of the system diagram effort. Thus, the earliest possible start date for the Phase Two effort is the day after completion of the system calculations. Phase Two will require some minimum duration just to put all of the information relating to the system down on paper, even if all necessary data about the system's equipment is already known. Consequently, the earliest possible completion date for the system diagram effort is determined by adding that duration to the Phase Two start date.

The latest allowable completion date for the Phase Two effort is determined by the requirement to provide data to the composite drawing in time for it to be completed by its latest allowable finish date. But the only parts of the composite drawing that have to be considered are those which are impacted

by the system under consideration. Most systems pass through more than one construction unit, and one of those unit composite drawings will have to be completed before any of the others for that system.

Therefore, as illustrated in Figure 3A, in order to identify the latest date by which the system's Phase Two diagram effort must be completed, it is necessary to a) identify all of the units in which the system will be installed, b) identify the earliest of the required unit composite drawing completion dates of those units, and c) back up from that date by the FF lag between the completion of the Phase Two effort and the earliest required UCD completion date.

Unit Composite Schedule Determination

The Unit Composite Drawing cannot complete until after the completion of the Phase Two diagram effort of every system installed in the unit. A two week FF lag has been assumed between the two for this project. The UCD must be completed in time to support the start of the Assembly Drawing of the controlling system type in the unit under consideration.

System Type Unit Scheduling

Figure 3B shows all of the activities associated with one system type. The Unit Assembly Drawing (UAD) for the system type has some duration associated with it. Once the drawing has been finished, and after an assumed two week lag, the Assembly Planning activity begins. This must be finished before the assembly of that system can start, but as shown in the figure, the fabrication related activities normally will control the overall process duration.

A two week start-to-start lag between the UAD and the Unit Fabrication Drawing (UFD) of the system type is assumed, but this could easily be varied when necessary. Fabrication Planning, including material ordering and preparation of work instructions and work authorizations, follows completion of the UFD and precedes the actual fabrication of parts. All of these activities must complete in time for the installation of parts in the first applicable stage of the construction assembly process. The first stage in which parts are to be installed in a unit will vary, depending on the system type

and the unit. Thus, in order to develop the integrated schedule, it will be necessary to identify, for each unit and for each system type in that unit, what construction stage will be the first stage for installation of that type of system.

As illustrated in Figure 3C, the first stage in which structural members will be assembled is stage 20. The first installation stage for other system types, such as piping, could be either 30, 40, 50 or 60 and will not necessarily be the same for all units. The overall duration of the activities enclosed within the dashed line in figure 3B probably will be different for each system type in a unit. The system type blocks in Figure 3C represent the dashed line coverage in Figure 3B. As shown in Figure 3C, one of the several system type assembly processes (Piping in this example) will have the earliest required start date, and this date will thus establish the date by which the unit's composite drawing must be finished.

Schedule Calculation Process

The overall calculation process which must be carried out can be illustrated by using all three parts of figure 3. First, by adding up all the durations and lag times for the activities within the dashed lines of figure 3B, the total duration from composite completion date to the start of the unit stage assembly process is found. By subtracting this duration from the scheduled start date for the unit stage assembly process, the required composite finish date for that system type in that unit is determined.

The next step, as shown in Figure 3C, is to compare that date for each of the system types in the unit and select the earliest. This establishes the latest allowable unit composite completion date.

Then, the latest allowable completion date of each system's Phase Two diagram effort is established by the steps illustrated in Figure 3A.

The system's Phase Two start date is calculated by subtracting the Phase Two duration from the Phase Two completion date. This also determines the date by which the System Calculation effort would have to complete if only the

diagram development were involved. However, if there is equipment to be procured for the system, it may be necessary to schedule the completion (and start) of the System Calculation effort earlier.

Equipment Controlled Dates

Three other dates for the required start of the System Calculation effort may be calculated, each associated with a separate aspect of the Equipment Procurement process. Figure 2A illustrates that the model used for this project assumes that preparation of equipment technical specifications, which is a necessary step in starting the Equipment Procurement process, starts after completion of System Calculations. Although it would be more precise to tie the two activities together with a finish-to-finish lag, since much of the technical specification effort could be done in parallel with the System Calculations, the modeled approach should result in fewest manhour expenditures and will give a more conservative scheduling approach. Figure 2A also illustrates that there may be many different types of equipment required for any single system. The significance of this is that the controlling dates of each of a system's equipments must be found and then the earliest date selected from among these.

Equipment Performance Data Path

As shown in Figure 2B, several activities occur between the date when work begins on the preparation of an equipment's technical specifications and the date when Performance Data (PD) is received from the equipment vendor. The time to accomplish these activities can be designated the PD overall duration. Since equipment performance data must be in hand before Phase Two of the diagram development effort can be completed, then the duration between the system calculation finish date and the Phase Two completion date cannot be less than the PD overall duration plus the time necessary to incorporate any changes resulting from that data into the diagram. Two weeks will be allowed for the lag time between receipt of PD and the Phase Two completion date.

Equipment Configuration Data Path

The time between the start of equipment technical specification preparation and the receipt of vendor configuration data (CD) will be designated the CD overall duration. The completion of the composite drawing for any unit in which that equipment appears will depend upon receipt of the equipment's CD. A two week lag will be assumed between receipt of CD and completion of any unit composite drawing in which that equipment is located.

There may be several identical items of equipment ordered for the same system, but located in different units. Thus, although the CD overall duration will be the same for all identical items of equipment, each unit installation must be considered when determining the scheduling implications. Furthermore, as indicated in Figure 4, there is no reason to assume that the first unit in which a piece of equipment will be installed is the same unit in which other parts of the system will be installed. Consequently, a separate calculation will have to be carried out to define the System Calc Completion date which is required based on the system's controlling equipment CD path.

Equipment Hardware Delivery Path

The final path to be considered is the path controlled by the equipment manufacturing process. A system may include more than one item of the same equipment, such as several identical pumps, some of which may be installed in different units. In such cases, the installation stage for each unit will have to be defined. The installation date for that unit/stage combination can then be determined. The earliest of these dates must then be selected as the controlling date for hardware installation for that equipment.

The total duration, from the finish of the System Calculations to the controlling installation start date, can then be subtracted from this date. The result will be the date by which the System Calculations must be completed, based on hardware installation requirements.

System Interdependencies

The final consideration in developing the drawing schedules is the interdependencies between drawings. All diagrams depend upon those arrangement and structural drawings which affect the areas through which their system must be routed, because these drawings provide background data for the diagrams. Many diagrams depend upon information from other diagrams because one system provides another system with some service. Thus, for purposes of identification, the one will be called the "Provider" and the other the "User".

For example, the Firemain may provide saltwater to an auxiliary saltwater system. During the system calculations for the firemain, the system designer will have to know the quantity and pressure of water which must be provided to the other system. The schedule for doing calculations for the user system will have to be established so that the information required by the firemain designer will be available in time for the firemain calculations to complete on time.

Thus, user system schedules must satisfy not only the demands of their own system and equipment installation dates, but also the demands of their provider systems. Allowances have been made in the scheduling calculations for cases where a user system is also a provider system to a third system. However, to preclude unnecessary complications in programming, this program has been developed so that no user system can also be a provider system to its provider system, even though there may be some cases where this could be true. In that event, this project's scheduling program will set both calculation completion dates to the same date and allow design managers to handle the iterative data flow problems.

Potential Critical Paths

General

The overall logic flow of the integrated drawing development and equipment procurement scheduling processes is illustrated in Figure 4, where the several possible controlling or critical paths are illustrated. This is a much simplified picture of the total process, since it shows only one system, only the first unit into which that system is installed, one system to that unit, only one equipment for the system and only one unit into that

equipment is installed. An actual system may be installed in many units and may have many different types of equipment in the system. Several items of each type of equipment may be needed and these may be installed in several different units. The complications involved in determining which of the system's equipments and related units control the date by which the system's calculations must complete - the date which controls all scheduling for the elements of the system - were discussed in the preceding chapter.

The No Equipment Case Path

The first potential critical path is that which would be involved if there were no equipment involved. Date F in Figure 4 is the date by which the Unit Assembly process must be completed for the controlling system type in the unit. In order to meet this date, the Composite drawing for the unit must be completed by date C, the Phase Two Diagram must be completed by date B and the System Calculations must be finished by date A1. This potential critical path flows through points A1, B, C, D, and E, to F. The "A" Date determined by this path will be identified as the System Diagram A Date, abbreviated as SDIA Date. For the No-Equipment case, A and A1 would be coincident.

The Equipment Performance Data Path

As indicated earlier, if equipment must be ordered for the system, then the Phase Two Diagram effort cannot be finished until the performance data (PD) of each equipment in the system is available. Thus it is necessary to determine the total time from finish of the system calculations to the delivery of the PD for each equipment in the system, A2-G in Figure 4, select the longest of these, and use that value as the system's equipment PD duration. Then, allowing a 2 week FF lag until Phase Two is complete, GB, the Phase Two duration based on equipment PD availability, A2B is determined.

The rest of the calculation for the duration of this potentially critical path is identical to that done for the no equipment case above. Thus, this path flows through points A2, G, B, C, D, and E, to F. The date A2 determined by this path will be identified as the Equipment's PD A Date, EPDA. This date must be determined for each of the system's equipments. The earliest of these will be the System's PD A date, SPDA.

The Equipment Configuration Data Path

Configuration data of an equipment must be in hand before the composite drawing can be completed in the areas where that equipment is located. Thus, the completion date of a unit composite drawing (UCD) is also dependent upon the latest CD delivery date, H, for all of the equipment located in the unit. Conversely, the latest allowable CD delivery date for any equipment in the unit will be determined by subtracting the FF lag time from the required UCD completion date. This lag time will be assumed constant at three weeks for all equipment and units.

As previously stated, the unit which controls the required delivery of an equipment's CD may be different from the unit which controls completion of the system's diagram effort. This is illustrated in Figure 4 by inclusion of the date C2, for the completion of the equipment's controlling unit's composite drawing, and the equivalent dates D2, E2, and F2.

The critical path which is defined by considerations of the availability of vendor configuration data, then, flows through points A3, H, C2, D2, and E2, to F2. The date A3 defined in this manner for each of the system's equipments will be identified as the Equipment CD A date, ECDA. The ECDA dates of each of the system's equipments must be compared to find the earliest, which will be the System's CD A Date, SCDA date.

The Equipment Hardware Installation Path

The path from A4 to K to L in Figure 4 is the path controlled by the availability of the system's equipment. Figure 2B illustrates all of the activities whose durations and lags make up the overall duration of that path.

In Figure 4, the earliest required installation date for the hardware is labeled L and corresponds with the Milestone in Figure 2B labeled "INST". The duration of path ~~A4-K-L~~, subtracted from the date L, will yield the required date A4, by which system calculations must be completed in order to have the equipment installed in time to satisfy the ship's erection schedule. The system calculation completion date so determined for each equipment can be called the Equipment Hardware A date, or EHWA date.

A comparison of each of the system's equipments must be made, to identify the earliest of these. That date will be the System's Hardware A date, or SHWA date.

Critical System Path Determination

The critical path for the system, if the system were independent of all other systems, would be the path that requires the earliest A date of the four paths considered above. This would be the System's Independent A Date, SINA. However, since most systems are dependent upon other systems for information in order to complete their calculations, the interdependencies between systems must also be considered before the true required completion date can be determined.

This can only be done after each system's independent A date is determined. If system 1 must provide information to system 2, then the calculations for system 1 must be completed before system 2's, by the FF lag time between the two system calculations. Thus, by using that lag to back off from the independent A date of system 2, a new, dependent A date, SDPA, is established for system 1. If system 1 provides information to more than one other system, then the SDPA date derived from each of those systems must be determined and compared with the system's SINA date to find the earliest of all of these. This will be the controlling date for setting the drawing and equipment procurement schedules, and will be designated the System A date, SYSA.

COMPUTER PROGRAM

General

Having developed an information flow logic that was supposed to support the development of integrated schedules, the next logical step was to use that information and develop the integrated schedules. To do so, two types of computer application programs were considered, a critical path networking program and a relational data base program. Both types of program are available from several sources. Furthermore, applications of both types suitable for micro-computers, or PC's, are available, as well as applications for mini- and main-frame computers. Because of the presumed greater accessibility of PC's, and thus greater potential utility of a program which could be run on them, PC applications were examined first. Of the programs investigated, the database program was found to be simpler to use. Thus, the integrated scheduling program has been developed on that system. The PC application was found to be fully capable of meeting the system requirements.

No attempt has been made to try other available database programs or to utilize programs for larger computers. The information provided herein serves only to demonstrate that one workable solution has been found and to provide the information necessary for successful implementation of that solution. Any shipyard having existing installed relational database systems or networking programs should be able to develop their own scheduling programs using the data provided in this report.

Data Base

General

The relational database application program that has been used for this project is R:BASE FOR DOS, a product of MICRORIM. The basic elements of this program are Tables, Forms, Reports, the specific Application program that controls the operation of the system and a number of individual programs that effect calculations necessary for generating controlling schedule dates. Each of these elements is explained briefly in the paragraphs which follow. Appendix A provides more detailed explanations of the elements and gives examples of each.

Tables

Each "Table" is in fact a separate database, where data related to some unique set of parameters can be stored. A Table consists of rows and columns of data. New data is added and existing data is modified on forms which are presented on the computer monitor. Other data in tables is calculated by the programs provided and then stored in a column of the table. Appendix A provides a more complete description of the contents of each table used in the program developed during this study.

Forms

The Forms element is an internal system which is used by the programmer to set up the appearance of the computer screens used by those who will enter the data that will be stored in the Tables. Forms have been developed for entry and for editing of each type of data required for scheduling. Examples are provided in Appendix A.

Reports

The Reports element is another internal RBASE system that a programmer may use to develop the format for any and all reports which are to be obtained from the system. Two types of reports have been developed; one for reviewing the contents of the tables of the database and the other for issuing schedules.

Application Programs

By running specific Application programs, operators may perform various functions, such as entering data into the database, modifying the data which has previously been entered, reviewing the data, or printing out the data in various formats. The application program developed for this study presents the user with a series of "menus" on the screen, from which the desired actions may be selected. This feature makes the use of this system extremely straightforward and minimizes operator training.

Scheduling Application Program

The specific application program that was developed for this integrated scheduling effort facilitates initial entry of all data concerning a ship's systems, equipment, and construction schedule. All such data can be modified

as necessary whenever required. The program then will do the calculations necessary to determine the early and late start and finish dates for each activity in the drawing development and equipment procurement processes, thus establishing the baseline schedule. Figure 5 identifies the various Tables that were created for storing baseline data relating to systems, equipment and the construction schedule. It also illustrates the interactions between the tables and the various software programs that were created in order to establish the controlling schedule dates.

After the shipbuilding project is started, the current estimated dates and the actual dates of accomplishment of any activity of interest must be entered into the system. Separate tables and separate data entry and editing screens have been provided to facilitate the updating of these data. Figure 6 illustrates how the data to create schedule reports is generated by combining data from the baseline data tables and the tables which contain current and actual schedule data.

Thus, all the data necessary for producing printed reports of drawing and equipment schedules is entered into or developed by the database program. By making appropriate selections from the options provided on the monitor screen, any desired Schedule report may be produced. The Schedules may be generated in whatever sorting sequence is desired by the shipyard's organizations and level of management. Sorts by system type may be most useful for individual Design Department Groups or Production Trades, while sorts by date or by unit will be of more use to other managers.

In addition, the program allows the current content of any of the database's Tables to be reviewed on the screen or printed out, a convenience for analyzing what combination of factors is controlling any scheduled date.

Computer Capability Required

The Relational Database System that has been used to develop the programs demonstrated herein is R:BASE FOR DOS, available from MICROIM. The full R:BASE FOR DOS program 5.25 inch disk version requires PC-DOS 2.0 or higher, 512K of main memory, a hard disk drive and one 5.25 floppy disk drive, plus a monitor. The 3.5 inch disk version requires PC-DOS 3.2 or higher. The

5.25 inch disk version was used for the subject application and all further discussion will be directed to that version. The scheduling application program has been developed on an AT-clone with 512K of main memory and a 20 MB hard disk. It has not been prepared for network use, but this option is available with R:BASE FOR DOS and is considered a logical and desirable next step.

Approximately 4 megabytes of disc storage are required for installation of the full R:BASE FOR DOS product, although only about 2 megabytes are required for those elements of the program that are needed for this scheduling application.

The storage requirements for the scheduling application program and associated data will vary depending upon the amount of data stored. The requirements for a project which involves 125 different system drawings, 1000 different items of equipment, 150 different units with an average of six system types per unit, and for which each system is installed in an average of ten units, is slightly over 1 MB. An allowance of a total of 2MB should cover any likely growth.

Using the Scheduling Application Program

General

The following paragraphs provide a brief description of how the program can be used and what it will provide. Appendix A includes additional information and a number of specific examples. A more detailed description of the details of the program and of its operation will be the subject of a separate report.

Screens

The use of the program involves use of three types of "screens", or images which appear on the monitor for the operator's guidance. Examples of each are provided in Appendix A.

The first type is a "menu" screen, which provides the operator with a listing of choices of action, any one of which can be selected by entering the appropriate number at the keyboard. Selection of an option on a

screen will either provide another menu screen with other options, cause an action such as printing of a report to occur, or provide one of the other screen types to appear on the monitor.

The other two screen types are for data entry or for data editing. The type for data entry permits entry only, while that for editing allows entry of new rows of data, deletion of rows of data or changes to individual fields of data.

Operating Modes and Operators

There are at least three fairly different modes of operating the system, and it probably will be desirable to have different personnel available for performing these differing functions.

The first mode involves managing the computer application program itself. This includes making modifications to the program as necessary to change the various screen formats as necessary to suit varying requirements of individual shipyards or different shipbuilding programs. Management of this scheduling program would also include investigating the data content of various tables if necessary to resolve apparent errors. Schedule program management would best be accomplished by a single individual, who will have to become familiar with the use of the R:BASE FOR DOS system and of the specific application program which has been developed. None of the other operators will need any understanding of computer programming.

The second operating mode involves entering the initial data and editing or updating that data. Ideally, initial data entry would be a one time effort, and in the vast majority of cases should be. Once a system or equipment and its supporting data, such as scheduled duration for the various activities relating to that system/equipment, are entered, it should not be necessary to make changes to those data. The values for these data should be determined by mid-level managers, who might enter the data directly at their own keyboards rather than having to write out the information for entry by others.

Reports

There are two types of reports generated by the specific application program which was developed for this study. Examples of each are provided in Appendix A.

The first report type displays the contents of individual tables of the database and thus will be of primary interest to the Scheduling Program Manager.

The second type of report provides the schedules which are the primary reason for this whole effort. Separate reports are generated for the development schedule for each type of drawing, i.e., diagrams, unit composite drawings, installation/assembly drawings and fabrication drawings, as well as for the equipment ordering schedule. As previously noted, each schedule report can be configured in various ways, to present the data in the most useful format for the users of the reports.

FINDINGS AND CONCLUSIONS

The following findings and conclusions are based on the results of the work done during the course of this study:

Information Flow

1. Finding:

The critical date in the scheduling process is the date by which a system's calculations must be completed. The calculations must be completed by the earliest date needed to satisfy one of the following requirements:

- a) The date by which phase two of the system diagram process must be completed, or
- b) The date by which the calculations of another system, which depend on information from the calculations for this system, must be completed, or
- c) The earliest date by which one of the system's equipments must be ordered.

2. Finding:

The date by which an equipment must be ordered will be controlled by the earliest date by which any of the following must occur:

- a) The equipment's Performance Data must be received in support of the system diagram completion,
- b) The equipment's Configuration Data must be received in support of the earliest of its Unit Composite Drawing completions, or
- c) The equipment itself must be received in support of its installation into the first of the units in which it is installed.

3. Finding:

Using the durations of activities and the logic flow developed during this study and described in this report, most equipment procurements were found to be controlled by the date by which equipment Configuration Data was needed to support the completion of the Unit Composite Drawings.

Conclusion:

Unless the selection of the required Purchase Order Award Date for an equipment takes into account the need to receive that equipment's Performance and Configuration Data in time to support the Design process, the shipyard will not be able to achieve the most orderly, efficient, cost effective design and construction effort.

Computer Program

1. Finding:

The computer program produced during the course of this study effort successfully computes the dates by which drawings must be developed and equipment must be ordered in order to meet the construction schedule. It produces schedule reports which allow the required dates to be managed effectively.

Conclusion:

Drawing Sections and Procurement Offices have a tool available that can be used to control all of their activities to ensure that required schedule dates are met. This tool is available in a form that is readily usable on mini-computers of the type which can be found already in most organizations.

SUMMARY

General

The effort accomplished under this project has been successful in identifying the information logic flow that is necessary for developing and integrating the schedules for drawing development and equipment procurement activities for modular shipbuilding programs. A computer application to identify the dates necessary for any activities to be started or completed was written and tested successfully, using elements of an impending building program as a pilot. With the logic flow of the information interfaces established, shipyards can use and expand upon the program presented herein or can develop their own computer programs for accomplishing the goals of the project.

The results of these efforts have clearly established the need for shipyards to consider the needs of the design process for performance data and configuration data from the suppliers of equipment, and the lead times required by the equipment suppliers to do so, when defining the dates by which equipment purchase orders must be awarded.

An ancillary result has been the highlighting of the need for improved communications between shipyards and equipment suppliers. The shipyards need to determine and define all of the data that they need as well as the equipment performance requirements, and they need to fully define the environment in which the equipment must operate. The vendors must recognize the importance of timely submittal of accurate performance and configuration data, and must work with the shipyards in defining the information which they, the suppliers, need in order to best respond to the shipyard's needs.

Future Work

In order for the computer program that has been developed during this study to be more useful, it should be modified to enable its use on a network of terminals. This would then permit drawing data for each drawing section to be entered at their own terminal, at their own convenience, and would allow them to obtain output reports on their own printers whenever they wanted one.

Another improvement would be to include the dates for receiving various ILS submittals from vendors, such as Reliability and Availability data, Failure and Effects Analyses, Technical Manuals, Training Documentation, etc. If the submittal dates for noise data, shock calculations or other deliverables were to be different than the dates for other data submittals, each could be separately tracked by modifying the system to incorporate these items.

Finally, to ease use of the program, a set of operating instructions is needed. A detailed description of how to use each of the various types of screens, when to make various calculations, how to modify the program, etc, similar to those developed for use of other computer application programs, is needed for this program.

Completion of the three improvements described above would provide shipyard personnel with a complete, documented scheduling and status keeping system for engineering and procurement efforts, tied in directly with the production schedules.

Attempted use of the program for a follow ship project and for another project which was unable to utilize modular construction practices, has identified the need for other modifications to be made to the existing program. These changes would allow the information flow requirements to be applied more effectively to these other types of shipbuilding programs.

ACKNOWLEDGMENTS

The author wishes to express sincere appreciation for the continuing support and advice received during every part of this effort. Particular thanks are due to personnel from the Design Engineering organization of Ingalls Shipyard Division for their ready and expert answers to questions, their readiness to help and for providing data for use during the testing of the computer program. Thanks are due also to the equipment suppliers who provided specific instances of problems with various shipyards and various shipbuilding programs due to lack of adequate communications during the contracting process. Finally, the assistance of the members of SNAME Shipbuilding Production Committee Panel SP-4, who encouraged this work to be done and provided many helpful comments in improving the content, is gratefully acknowledged.

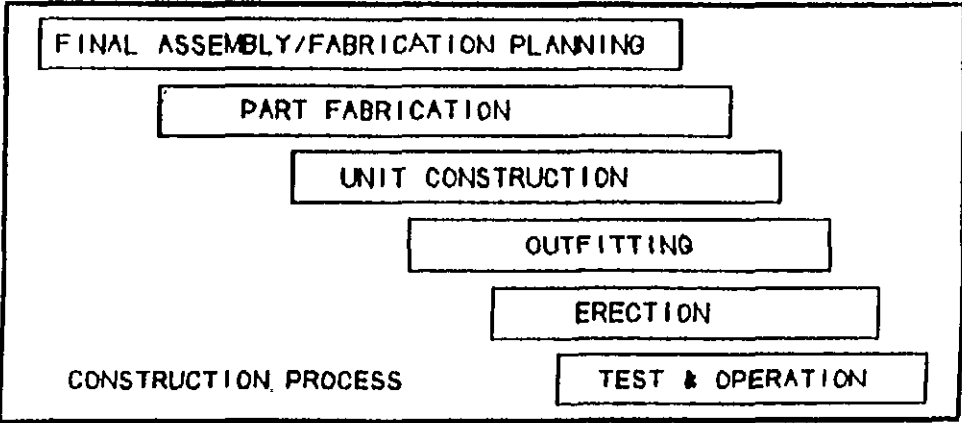
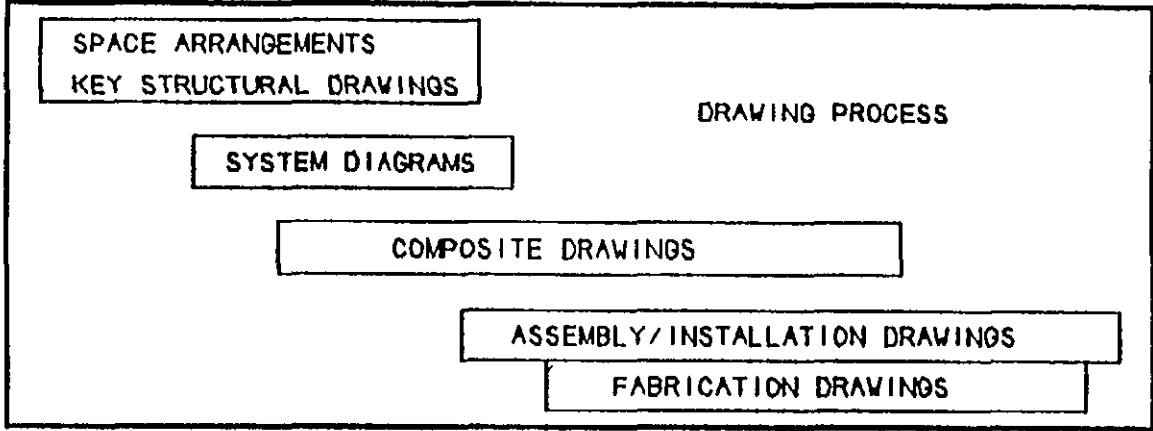

DRAWING/PROCUREMENT/CONSTRUCTION PROCESSES

FIGURE 1

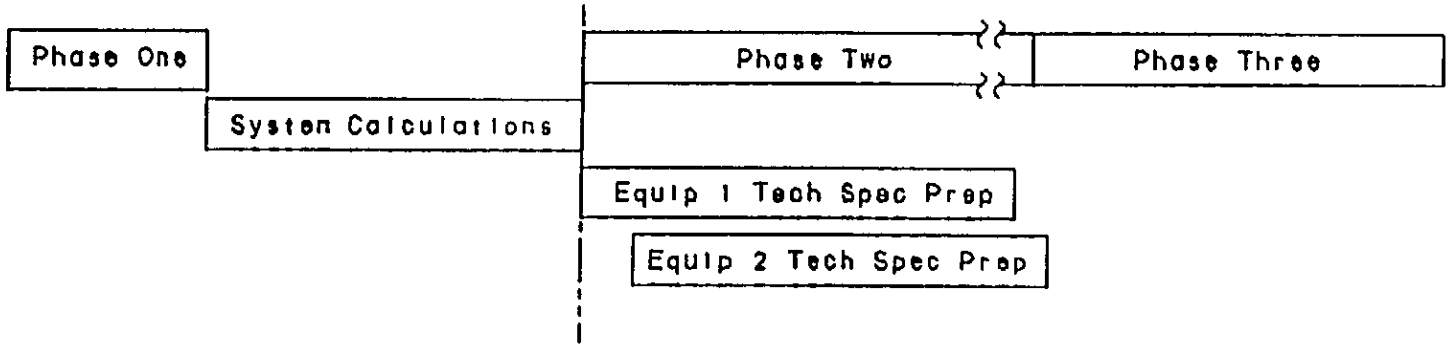

SYSTEM DIAGRAM PROCESS ACTIVITIES

Figure 2A

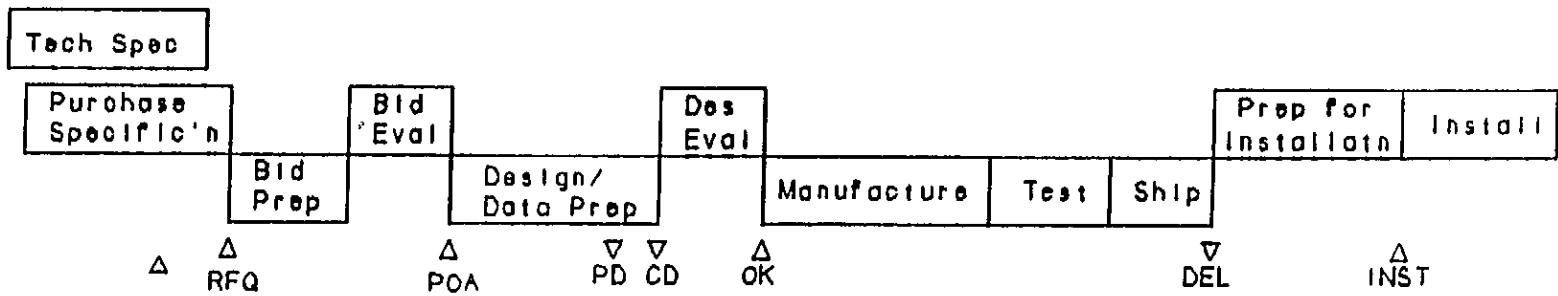

EQUIPMENT PROCUREMENT PROCESS ACTIVITIES

Figure 2B

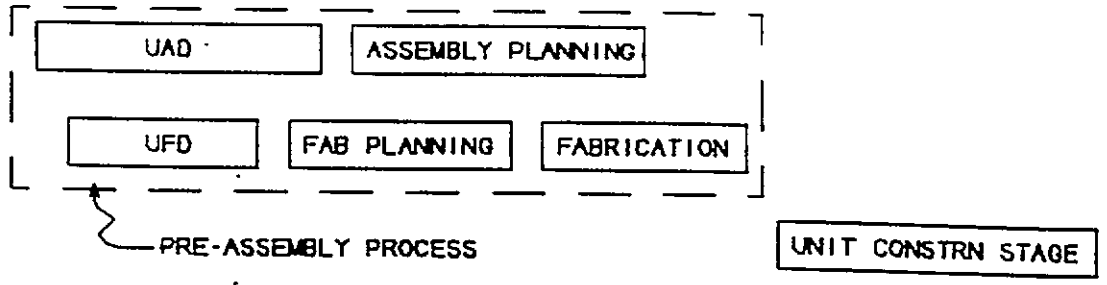

UNIT ASSEMBLY PROCESS FOR EACH SYSTEM TYPE

FIGURE 3A

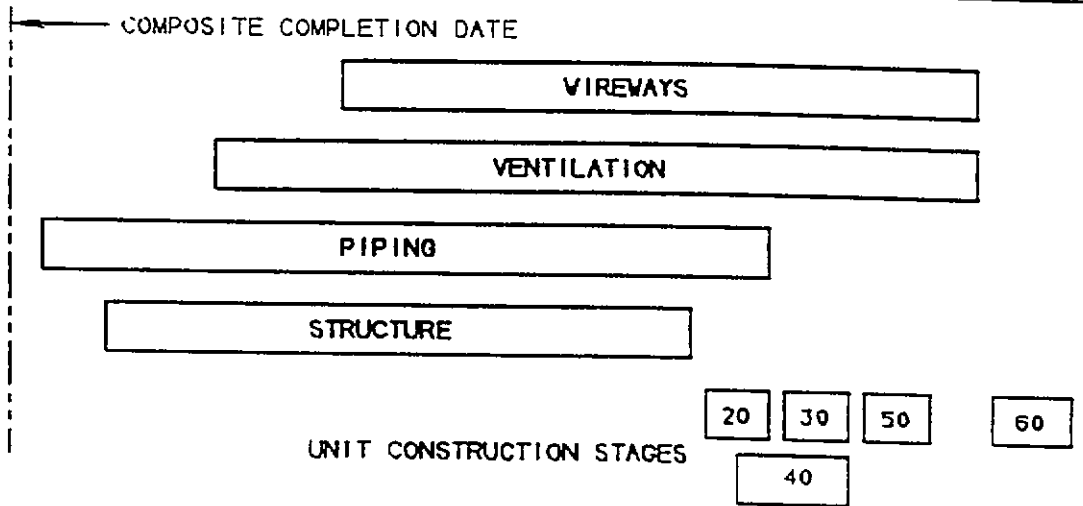

UNIT ASSEMBLY PROCESS FOR ALL SYSTEM TYPES IN A UNIT

FIGURE 3B

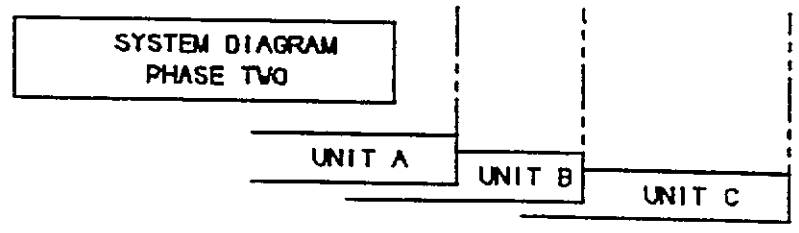

SYSTEM DIAGRAM - UNIT COMPOSITE DEPENDENCY

FIGURE 3C

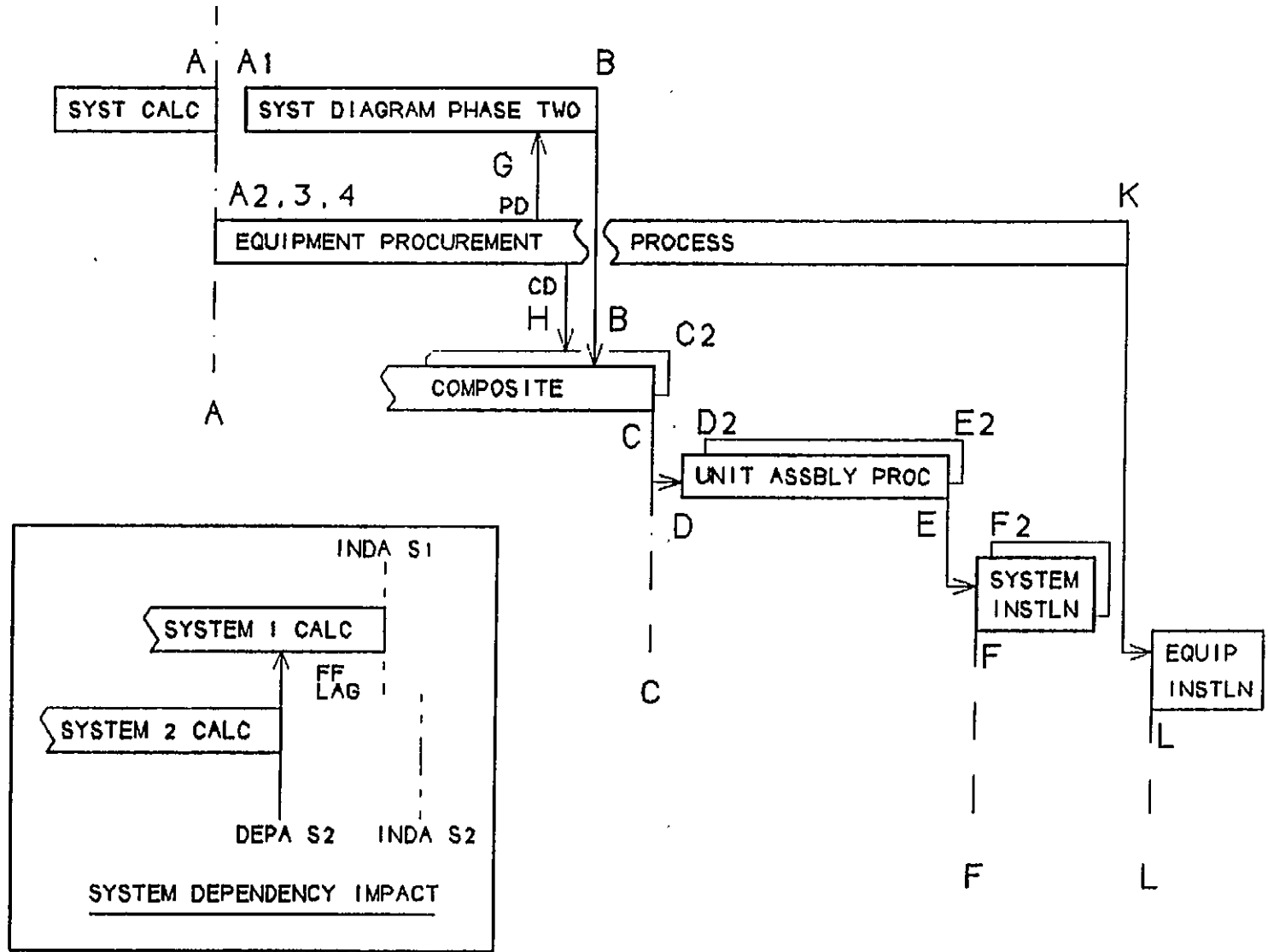

FIGURE 4

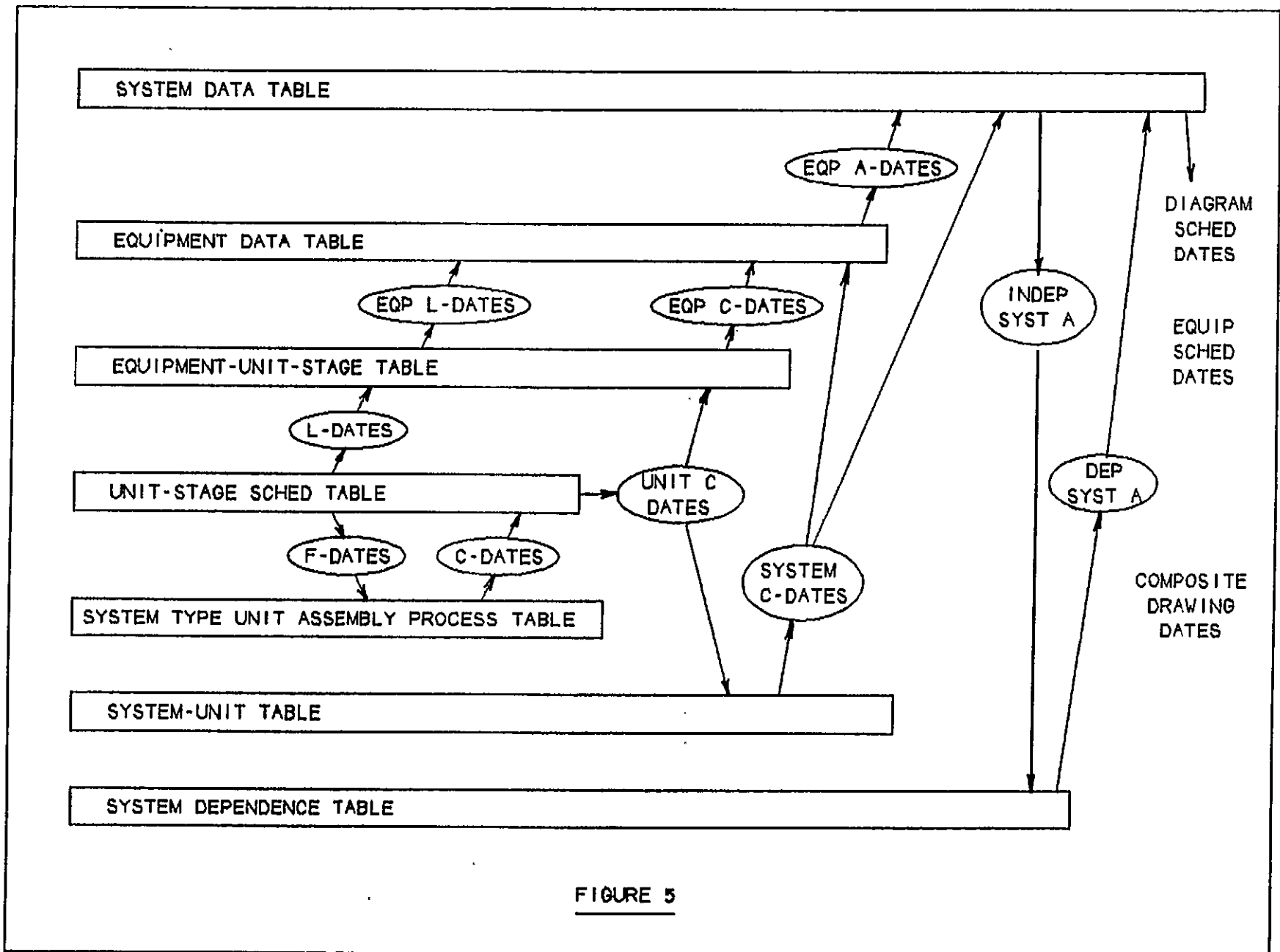

FIGURE 5

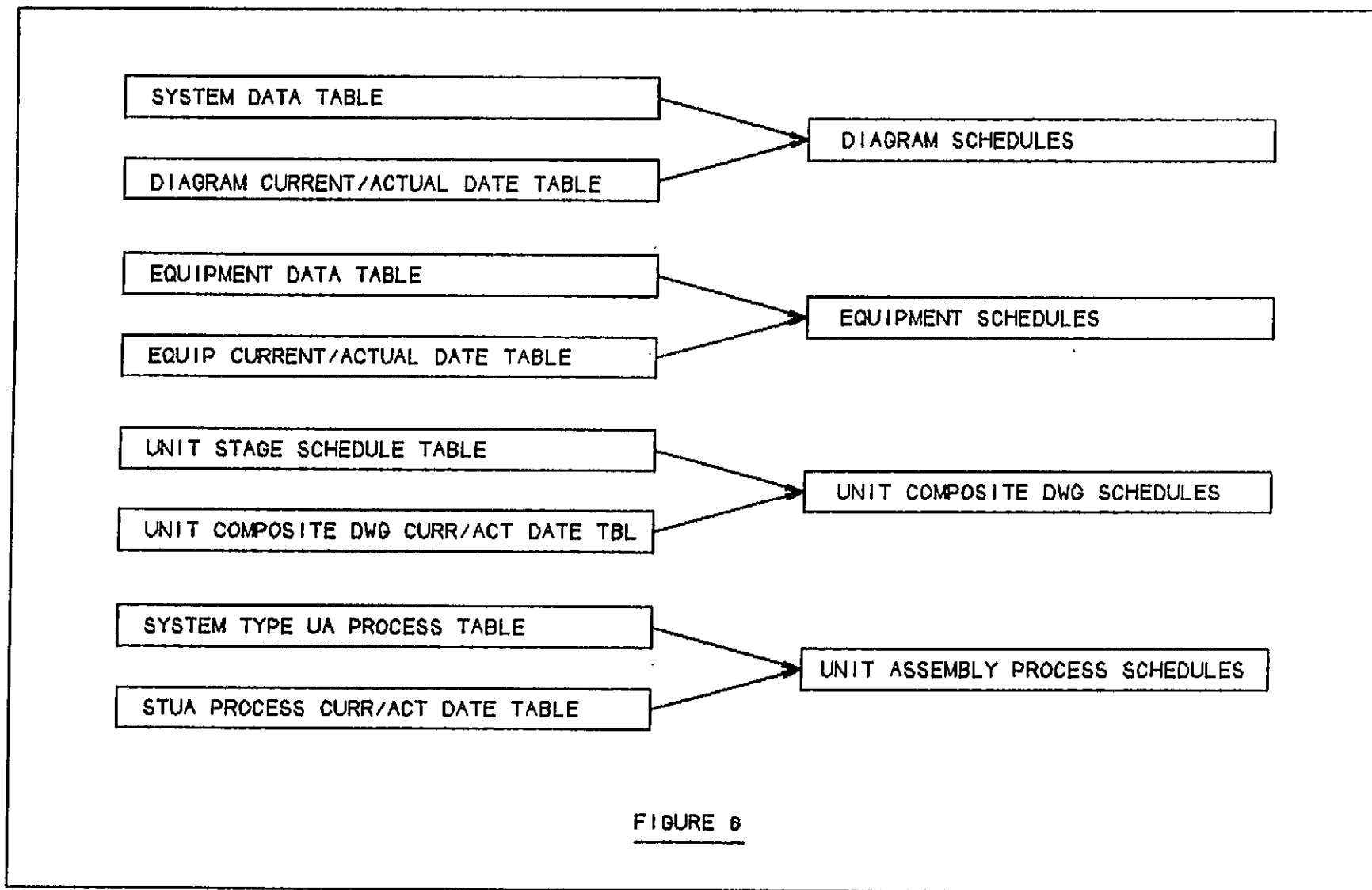

FIGURE 6

COMPUTER PROGRAM ELEMENTS

General

Setting up a database program normally initially involves determining what data is needed and selecting the most effective way to store that data. This results in identifying what tables are needed, and what columns are needed for each row of each table. The next step is to create the forms for entering and editing data, after which the format of any reports from the system must be established. Any software programs needed for calculating data and manipulating data between tables are then generated, and finally, the specific application program for tying these all together is prepared.

The results of these various steps for the scheduling program developed during this study are presented in this Appendix, but will be presented in the order in which the program would be used.

Screens

Menu Screens

Figure A-1 illustrates two of the various menu screens that have been developed for the application program of the pilot project. When the operator, looking at the screen shown in Figure A-1-a, decides to print a report of the content of one of the tables discussed above, he enters the number 3 at the key-board. This will cause the menu listed in figure A-1-b to appear on the screen. Entering one of the numbers listed there will cause the printer to generate one of the reports discussed under Tables, below.

Figure A-2-a shows the complete menu tree that is available from the menu in Figure A-1-a. Figure A-2-b displays information that is available from the RBASE system for use by the Scheduling Program Manager when developing the application program.

Data Entry and Editing Screens

Initial Data Screens

The System Data Entry Screen, Figure A-3-a, is used for entering initial system data into 5 different tables. After entering data into this form, it is then necessary to use other data editing screens, such as the one for the System Unit Combination Data Table shown in Figure A-3-b, to add additional data to other tables.

Current Data Screens

Screens such as the one shown for System Diagrams in Figure A-4-a are used to enter data into the tables which contain current and actual schedule dates. This data entry screen is used for the initial entry of current schedule data. Only the fields in the Current and Actual data rows can be filled in by the operator. The scheduled early and late start and finish dates are extracted by the computer from the baseline schedule, and placed on the screen without any input from the operator for guidance in establishing the initial "current" dates.

The subsequent updating of the schedule data is accomplished using a data editing screen such as shown in Figure A-4-b. Again, the top two lines of data cannot be changed by the operator, but any of the fields for current dates can be changed and data can be added in the fields for actual dates.

Tables

A number of tables were needed to store information of different types. Figures 5 and 6 of the main report illustrated what tables were created, how the information from each table is used to provide data to other tables through various calculation programs and how the data from pairs of tables is combined to create schedule reports. The functions of each of the tables is described in the following paragraphs.

System Data Table

This table includes all information which is relevant to each system, with the exception of current status for system diagrams. The table contains one row per system. Columns of each row contain one system's name, symbol, diagram numbers, and the duration of each phase of the development of the system diagram. All of these data must be entered from the computer keyboard, aided by the data entry screens that are provided.

Each row also includes columns containing the dates by which the system diagram schedules are controlled. These dates are calculated by various computer programs provided and are then automatically stored in this table, where they are then used as source data for the diagram development schedule. A listing of the data elements that are stored in the columns of this table is provided in Figure A-5. No attempt to define each of the data elements will be made in this report. The table is identified within the computer program as SYSDATAT. The contents of this table are accessible through generation of a report, as shown in Figure A-6.

System - Unit Table

The identifying symbol for every construction unit in which a system is located is entered into this table, along with the system identifying symbol. Thus, there may be many rows in this table for each system, but only one row for each system-unit combination. This table is identified as SYSUNITT and its contents are as shown in Figure A-7. Each row contains the system symbol, a unit number, and the Unit C-date for that unit; the Unit C-date being that date by which the unit's Composite drawing must be completed in order for the construction schedule to be met. One of the computer program subroutines searches this table and, for each system, compares the Unit C-dates for all units of the system, selects the earliest of these and stores it, the System C-date, in the System Data Table's row for that system and also into any rows in the Equipment Data Table that relate to that system's equipment. These calculations are illustrated in Figure 5 by the "bubble" labeled "System C-Dates".

System-Type Unit Assembly Process Table

Data related to the activities in the unit assembly process for each system-type are stored in this table, which is identified as SYTPROCT, where every row represents a unique combination of unit and system type. As previously described, the earliest construction stage during which each different system-type will be installed in a unit must be separately determined, for scheduling the activities of that system-type's unit assembly process. The durations for each of the activities in that process are entered into this table and edited through its own data entry and edit forms.

The installation date for the construction stage for each system-type in each unit, the System-Type Unit F-date, is obtained from the Unit-Stage Schedule Table and stored in this table. Having the F-date and all of the activity durations in the same row, allows immediate calculation of the System-Type's Unit C-date, which then also is stored in the row. The table's contents are shown in Figure A-8.

Unit-Stage Schedule Table

The construction schedule data must be entered into this table, UNSTSKDT. (An alternative approach would be to modify the columns of this table to accept duration data for each stage of construction of each unit, and the unit erection date, and generate all other start and completion dates for the construction schedule.) Each row of the table contains the dates for starting every stage of the unit's construction process, or sufficient information for those dates to be calculated. See Figure A-9. As currently configured, the program allows the start date of each stage to be identified as a number of weeks after contract award. The current program then allows the assumed or actual contract award date to be entered, after which it calculates and stores the calendar dates for starting each stage. The dates in this table are the source for the System-Type F-dates stored in the SYTPROCT table and for the Equipment-Unit L-dates stored in the Equipment-Unit Combination Table. See Figure 5.

Since this is the only table where each unit is identified uniquely, row by row, it is used to store the Unit C-dates. Once the F-dates have been extracted from this table and stored in the SYTPROCT table (where

the System-Type C-dates are immediately calculated, automatically), another subroutine is used to select the earliest of each unit's several System-Type C-dates. That date is then stored in the Unit C-date column of this table.

Equipment Data Table

As the name implies, this table is used to store data relating to each type of equipment for each system. Initially, duration data for each activity of the equipment procurement process must be entered. Three separate computer programs are used to obtain information from other tables and store the results in this table. The three possible equipment related A-dates are determined and stored in this table as a result of these calculations. The earliest of these is identified and stored in the Equipment A-date column. The contents of this table are as shown in Figure A-10.

Equipment-Unit-Stage Table

It is not uncommon for several items of the same, identical equipment to be located in more than one location on a ship. When those locations are in different construction units, the assembly schedules for each of those units must be considered in order to identify the controlling date for ordering the equipment. This table is provided for entering and storing the unique unit-stage installation combinations for each item of equipment.

The scheduled installation date for each of these equipment-unit-stage combinations is selected from UNSTSKOT and stored, as the Equipment-Unit L-date, in this table. A separate calculation is made in order to select the Unit C-date from the UNSTSKOT and store it here for each equipment-unit combination. The contents of the columns of this table are displayed in Figure A-11.

Subsequently, the earliest of the Equipment-Unit F-dates and of the Equipment-Unit C-dates are selected and stored as the Equipment L-date and the Equipment C-date, respectively, in the Equipment Data Table.

System Dependency Table

Each row in this table contains data describing the interdependencies of system diagrams. Each user system is originally listed with each system which provides services to it. However, because of the possibility of multiple dependencies, a separate computation program has been provided to identify multiple dependencies and revise required schedule dates accordingly. See Figure A-12 for SYSDEPT contents.

Schedule Status Tables

Four additional tables have been created for storing data relating to current estimated schedule dates and actual dates. The four tables cover diagram schedule data, equipment schedule data, unit composite drawing data and system-type unit assembly process activities data, respectively. The data in these tables are used for preparing reports of schedules and/or schedule status. Figure A-13 is a report of the content of the table containing current and actual dates for System Diagram activities, and illustrates the content of each of these four tables.

The screens used for data entry provide the early and late dates for start and finish of each of the activities for which current estimated data and actual data are to be provided.

Reports

Schedule Reports

Figures A-14 to A-18 illustrate schedules that can be generated from the report formats established for the pilot project. Figures A-14 and A-15 both apply to the same Diagram Schedules, but A-14 is sorted alphabetically by System Name while A-15 is sorted by Phase One Start date.

Data Table Content Reports

Figures A-6 through A-12 are examples of the reports which print out the data that is contained in the tables of the database. The primary purpose of these reports is to verify the accuracy of the data that is contained in the tables. Examination of these figures will show rows that need

data, redundant rows, etc., that need to be corrected. Another significant result from observing the contents of the tables is verification that the application program accomplishes what it was intended to accomplish.

Computer Program Development

Calculation Programs

A number of separate programs were needed in order to carry out all of the calculations that are necessary to identify the controlling dates for scheduling purposes. Each calculation program may be accomplished either generally, to recalculate every date, or selectively, when relatively minor changes or additions have been made to initial data. The Application Program as currently written generally requires the choice of general or selective calculation to be made from the keyboard using a menu. This can be changed easily to have calculations occur automatically whenever data entry has been finished.

Application Program

This is the program that provides the overall structure for accomplishing all tasks that must be performed to enter data and produce reports. It runs automatically and provides a series of menus, each of which lists choices for the operator to make in order to accomplish each of the tasks in the entire scheduling process. The menu screens that control the application were discussed previously.

Program Code Availability

The Application Program coding is too long and the individual calculation programs are too numerous to be included in this report, but are available upon request from the Program Manager of SP-4 or from the author.

MENU FOR DATA ENTRY, UPDATE, CALCS & TABLE CONTENT REPORTS

- (1) UPDATE DATA
- (2) RECALCULATE AFTER UPDATING DIAGRAM, EQUIPMENT OR UNIT DATA
- (3) GET REPORTS
- (4) ENTER INITIAL DATA
- (5) DO CALCULATIONS AFTER ENTERING INITIAL DATA
- (6) ENTER PROGRAM NAME, DESIGNATOR, AWARD DATE
- (7) QUIT

Figure A-1-a

TO PRINT THE CONTENT OF A TABLE

- (1) PRINT SYSTEM/DIAGRAM DATA TABLE
- (2) SYSTEM/UNIT TABLE
- (3) SYSTEM DEPENDENCY TABLE
- (4) EQUIPMENT DURATION DATA TABLE
- (5) EQUIPMENT/UNIT COMBINATIONS
- (6) UNIT DRAWING/PLANNING/FAB DURATIONS
- (7) UNIT-STAGE SCHEDULE TABLE DATA

Figure A-1-b

```

(Main      ) MENU FOR DATA ENTRY, UPDATE, CALCS & TABLE CONTENT REPO
├──(UPDATE ) UPDATE DATABASE DATA
│   ├──(SYSDIAM ) SYSTEM RELATED DATA TABLES UPDATE MENU
│   ├──(EQPINFOM) EQUIPMENT INFORMATION UPDATE MENU
│   ├──(UNITDWGM) UNIT DRAWING/PLANNING/FABRICATION UPDATE MENU
│   └──(UNITSTGM) UPDATE UNIT-STAGE SCHEDULING DATA
├──(RECALCSM) RECALCULATION MENU
├──(REPORTSM) SELECT THE TYPE OF REPORT DESIRED
│   └──(PRNTTBLM) TO PRINT THE CONTENT OF A TABLE
├──(DATAENTM) DATA ENTRY ACTIONS
├──(INITCLCM) CALCULATIONS AFTER INITIAL DATA ENTRY
│   └──(INDCALCM) INDIVIDUAL CALCULATION MENU

```

] Up [] Down [F3] Actions
Application IPSKMOD1 --- Database IP

Figure A-2-a

<pre> MENU FOR DATA ENTRY, UPDATE, CALCS & TABLE CONTENT REPORTS (1) UPDATE DATA (2) RECALCULATE AFTER UPDATING DIAGRAM, EQUIPMENT OR UNIT DATA (3) GET REPORTS (4) ENTER INITIAL DATA (5) DO CALCULATIONS AFTER ENTERING INITIAL DATA (6) ENTER PROGRAM NAME, DESIGNATOR, AWARD DATE (7) QUIT </pre>

```

Menu selection 1 - Process menu:  UPDATE
Menu selection 2 - Process menu:  RECALCSM
Menu selection 3 - Process menu:  REPORTSM
Menu selection 4 - Process menu:  DATAENTM
Menu selection 5 - Run custom/macro/template procedure:  DATESETP
                  Process menu:  INITCLCM
Menu selection 6 - Load using form:  AWARDAYF
Menu selection 7 - Exit
Press any key to continue

```

] Up [] Down [F3] Actions
Application IPSKMOD1 --- Database IP

Figure A-2-b

Add Duplicate Edit again Discard Quit		
***** DIAGRAM DATA *****		
SYSTEM NAME:	SYMBOL:	TYPE:
DIAGRAM NUMBERS		
SHIPYARD'S:	OWNER'S CONTRACT DWG:	
	DETAILED DWG:	
EQUIPMENT COVERED BY DIAGRAM	EQP SYMBOLS	SYSTEMS WHICH PROVIDE SERVICE
NAME _____ SYMBOL _____		SYMB _____ NAME _____
[ESC] Done [F2] Clear field [Shift-F2] Clear to end [Shift-F10] More Form: SYSDATAF Table: SYSUNITT Field: SYSTSYMB Page: 1		

Figure A-3-a

Edit Save Add new Delete Reset Previous Next Quit		
UNITS INTO WHICH PARTS OF THE SYSTEM ARE TO BE INSTALLED		
SYSTEM SYMBOL	SYSTEM NAME	UNIT NUMBER
AF	AFFF DISTRIBUTN	-
[ESC] Done [F2] Clear field [Shift-F2] Clear to end [Shift-F10] More Form: SYSUNTEF Table: SYSUNITT Field: SYSTSYMB Page: 1		

Figure A-3-b

Add Duplicate Edit again Discard Quit

Enter/Edit Current Scheduled and Actual Dates For Diagrams :

SYSSYMB	SHIPYARD DWG NO		CUSTOMER DWG NO		CONTR DES DWG NO		CONTR DES DWG NO	
	PHASE ONE		CALC		PHASE TWO		PHASE THREE	
	START	FINISH	START	FINISH	START	FINISH	START	FINISH
FM								
								MOSD07B
Early:					07/13/90	10/16/90	10/19/90	01/22/91
Late :	05/25/90	06/12/90	06/15/90	07/10/90	11/16/90	02/19/91	02/22/91	05/28/91
Curr :								
Act :								
Early:								
Late :								
Curr :								
Act :								

[ESC] Done [F2] Clear field [Shift-F2] Clear to end [Shift-F10] More
 Form: DIACRACF Table: DIACRACF Field: CSPHASE1 Page: 1 Changed

Figure A-4-a

Edit Save Add new Delete Reset Previous Next Quit

Enter/Edit Current Scheduled and Actual Dates For Diagrams :

SYSSYMB	SHIPYARD DWG NO		CUSTOMER DWG NO		CONTR DES DWG NO		CONTR DES DWG NO	
	PHASE ONE		CALC		PHASE TWO		PHASE THREE	
	START	FINISH	START	FINISH	START	FINISH	START	FINISH
FM	-							
								MOSD07B
Early:					07/13/90	10/16/90	10/19/90	01/22/91
Late :	05/25/90	06/12/90	06/15/90	07/10/90	11/16/90	02/19/91	02/22/91	05/28/91
Curr :	08/15/90	08/31/90	09/03/90	09/28/90	10/01/90	11/23/90	11/26/90	01/18/91
Act :	-	-	-	-	-	-	-	-
HS	560-60				560-34567890F			
Early:					12/03/90	01/04/91	01/07/91	02/08/91
Late :	11/19/90	11/23/90	11/26/90	11/30/90	01/28/91	03/01/91	03/04/91	04/05/91
Curr :	-	-	-	-	-	-	-	-
Act :	-	-	-	-	-	-	-	-

[ESC] Done [F2] Clear field [Shift-F2] Clear to end [Shift-F10] More
 Form: DIACRACF Table: DIACRACF Field: SYSSYMB Page: 1

Figure A-4-b

Table: SYSDATAT No locks)

Read Password: No

Modify Password: No

Column definitions

#	Name	Type	Length	Key	Expression
1	SYSTNAME	TEXT	15 characters		
2	SYSTSYMB	TEXT	2 characters	yes	
3	SYSTTYPE	TEXT	1 characters		
4	SYDIAGNR	TEXT	13 characters		
5	OWNRCDNR	TEXT	13 characters		
6	OWNRDDNR	TEXT	13 characters		
7	DURPHAS1	INTEGER			
8	DURCALC	INTEGER			
9	DURPHAS2	INTEGER			
10	DURPHAS3	INTEGER			
11	MNSYSCDA	DATE			
12	SYDIADAY	DATE			('MNSYSCDA'-7* DURPHAS2)
13	MNEQADAY	DATE			
14	MNINDADA	DATE			(MIN('SYDIADAY' , MNEQADAY))
15	MNDEPADA	DATE			
16	LFSYSCLC	DATE			(MIN('MNINDADA' , MNDEPADA))

Column definitions

#	Name	Type	Length	Key	Expression
17	LSSYSCLC	DATE			('LFSYSCLC'-7* 'DURCALC'+3)
18	LFPHASE2	DATE			('MNSYSCDA'-14)
19	LSPHASE1	DATE			('LSSYSCLC'-7* 'DURPHAS1')

Current number of rows: 11

Figure A-5

PRINTOUT OF SYSTEM DATA TABLE DIAGRAM DATA CONTENT
 Printed on 01/16/89 at 14:52:24

SYSTEM NAME	SYMB TYP	SHIPYARD'S DIAG NR	OWNER'S DWG NUMBER
DURATIONS-WKS		DATES	
PH1 CLC PH2 PH3	MNSYSCDA	DIAGADAY MNEQADAY	MNINDADA MNDEPADA SYSTADAY
====	=====	=====	=====
AFFF DISTRIBUTN 2 4 8 8	AF P	SYDNR XXXXXD 03/05/91 01/08/91 09/18/90	MM053D180 09/18/90 06/26/90 06/26/90
AUX SW COOLING 4 5 10 13	AS P	SYDNR YYYYYYE 03/15/91 01/04/91 09/07/90	MM055D16D 09/07/90 06/26/90 06/26/90
COMPRESSED AIR 3 4 8 5	CA P	- 02/12/91 12/18/90 09/25/90	M05D12 09/25/90 12/10/99 09/25/90
CHILLED WATER 2 3 10 12	CW P	444455023-12 03/15/91 01/04/91 11/02/90	01234-12-333D 11/02/90 12/10/99 11/02/90
DRAIN & BALLAST 4 4 10 12	DB P	- 03/15/91 01/04/91 10/12/90	M05D08A 10/12/90 06/19/90 06/19/90
FIREMAIN 3 4 14 12	FM P	- 03/05/91 11/27/90 10/12/90	M05D07B 10/12/90 07/10/90 07/10/90
HYDRAULIC STRG 1 1 5 5	HS P	560-60 03/15/91 02/08/91 11/30/90	- 11/30/90 12/10/99 11/30/90
PRAIRIE MASKER 3 3 8 8	PM P	- 01/22/91 11/27/90 07/31/90	M08D010 07/31/90 06/12/90 06/12/90
POTABLE WATER 2 4 12 13	PW P	- 03/05/91 12/11/90 09/25/90	- 09/25/90 09/18/90 09/18/90
SANITARY FLUSHG 4 5 10 10	SF P	- 03/19/91 01/08/91 09/11/90	M05D040 09/11/90 06/26/90 06/26/90
MAIN SW COOLING 4 5 10 13	SW P	- 01/22/91 11/13/90 07/24/90	M05D 07/24/90 12/10/99 07/24/90

Figure A-6

SYSTEM-UNIT COMBINATION TABLE DATA PRINTOUT

SYMB	NAME		C DATE
AF	AFFF DISTRIBUTN	1421	03/15/91
AF	AFFF DISTRIBUTN	1422	03/29/91
AF	AFFF DISTRIBUTN	1423	04/02/91
AF	AFFF DISTRIBUTN	1433	03/05/91
AF	AFFF DISTRIBUTN	1510	04/02/91
AF	AFFF DISTRIBUTN	1520	03/19/91
AF	AFFF DISTRIBUTN	1620	05/07/91
AF	AFFF DISTRIBUTN	2400	07/30/91
AF	AFFF DISTRIBUTN	2510	06/18/91
AF	AFFF DISTRIBUTN	-	-
AS	AUX SW COOLING	1421	03/15/91
AS	AUX SW COOLING	1422	03/29/91
AS	AUX SW COOLING	1423	04/02/91
CA	COMPRESSED AIR	1130	09/10/91
CA	COMPRESSED AIR	1230	07/16/91
CA	COMPRESSED AIR	1411	02/12/91
CA	COMPRESSED AIR	1421	03/15/91
CA	COMPRESSED AIR	1422	03/29/91
CA	COMPRESSED AIR	1423	04/02/91
CA	COMPRESSED AIR	1433	03/05/91
CA	COMPRESSED AIR	1510	04/02/91
CA	COMPRESSED AIR	2510	06/18/91
CW	CHILLED WATER	1421	03/15/91
CW	CHILLED WATER	1422	03/29/91
CW	CHILLED WATER	1423	04/02/91
CW	CHILLED WATER	1510	04/02/91
CW	CHILLED WATER	1610	04/02/91
DB	DRAIN & BALLAST	1110	10/15/91
DB	DRAIN & BALLAST	1210	06/18/91
DB	DRAIN & BALLAST	1220	06/25/91
DB	DRAIN & BALLAST	1320	04/23/91
DB	DRAIN & BALLAST	1421	03/15/91
DB	DRAIN & BALLAST	1422	03/29/91
DB	DRAIN & BALLAST	1423	04/02/91
DB	DRAIN & BALLAST	1510	04/02/91
DB	DRAIN & BALLAST	1610	04/02/91
FM	FIREMAIN	1421	03/15/91
FM	FIREMAIN	1422	03/29/91
FM	FIREMAIN	1423	04/02/91
FM	FIREMAIN	1433	03/05/91
FM	FIREMAIN	1510	04/02/91
FM	FIREMAIN	1520	03/19/91
FM	FIREMAIN	1610	04/02/91
FM	FIREMAIN	1620	05/07/91
FM	FIREMAIN	2100	11/26/91
FM	FIREMAIN	2200	11/19/91
FM	FIREMAIN	2310	06/04/91
FM	FIREMAIN	2400	07/30/91
FM	FIREMAIN	2510	06/18/91
HS	HYDRAULIC STRG	1421	03/15/91
PM	PRAIRIE MASKER	1412	01/22/91
PM	PRAIRIE MASKER	1421	03/15/91
PM	PRAIRIE MASKER	1422	03/29/91
PM	PRAIRIE MASKER	1433	03/05/91

SYSTEM TYPE UNIT ASSEMBLY PROCESS TABLE DATA
Printed on 01/15/89 on 15:07:38

SYS TYP	UNIT	STG	:-----DURATIONS-----: WEEKS-----:							SYSTYPE "F" DATE	SYSTYPE "C" DATE
			UAD	UAP	SS	UFD	UFP	UFF	TOT		
P	1110	50	8	4	2	7	4	6	29	05/08/92	10/15/91
S	1110	20	6	3	2	4	3	3	22	04/03/92	10/29/91
W	1110	50	8	3	2	6	3	2	23	05/08/92	11/26/91
P	1120	50	8	4	2	7	4	6	29	04/10/92	09/17/91
S	1120	20	6	3	2	4	3	3	22	03/06/92	10/01/91
P	1130	50	8	4	2	7	4	6	29	04/03/92	09/10/91
S	1130	20	6	3	2	4	3	3	22	02/21/92	09/17/91
P	1210	50	8	4	2	7	4	6	29	01/10/92	06/18/91
S	1210	20	6	3	2	4	3	3	22	12/13/91	07/09/91
P	1220	50	8	4	2	7	4	6	29	01/17/92	06/25/91
S	1220	20	6	3	2	4	3	3	22	12/06/91	07/02/91
P	1230	50	8	4	2	7	4	6	29	02/07/92	07/16/91
S	1230	20	6	3	2	4	3	3	22	01/03/92	07/30/91
P	1310	40	8	4	2	6	4	6	28	11/08/91	04/23/91
S	1310	20	6	3	2	4	3	3	22	11/08/91	06/04/91
W	1310	40	8	3	2	6	3	3	24	11/08/91	05/21/91
P	1320	40	8	4	2	6	4	6	28	11/08/91	04/23/91
S	1320	20	6	3	2	4	3	3	22	11/08/91	06/04/91
P	1330	40	8	4	2	6	4	6	28	12/06/91	05/21/91
S	1330	20	6	4	2	4	3	5	24	12/06/91	06/18/91
P	1411	50	14	6	2	10	6	8	36	12/06/91	03/26/91
S	1411	20	12	6	2	8	8	10	38	11/08/91	02/12/91
W	1411	50	8	5	2	4	4	3	23	12/06/91	06/25/91
P	1412	50	10	5	2	8	6	8	34	11/22/91	03/26/91
S	1412	20	13	4	3	12	6	8	39	10/25/91	01/22/91
W	1412	50	8	4	2	6	4	4	26	11/22/91	05/21/91
P	1413	50	12	6	2	8	6	10	36	11/22/91	03/12/91
P	1414	50	12	6	2	8	6	10	36	01/03/92	04/23/91
P	1415	50	12	6	2	8	6	10	36	01/03/92	04/23/91
P	1421	40	10	4	3	6	3	8	30	11/11/91	04/12/91
S	1421	20	12	4	3	8	3	8	32	10/28/91	03/15/91
W	1421	50	8	5	2	4	4	3	23	12/30/91	07/19/91
P	1422	30	12	4	3	7	3	9	32	12/30/91	05/17/91
S	1422	20	12	4	2	8	4	10	34	11/25/91	03/29/91
W	1422	50	8	5	2	4	4	3	23	02/03/92	08/23/91
P	1423	40	12	6	2	8	6	8	34	11/29/91	04/02/91
S	1423	20	12	6	2	8	8	10	38	01/03/92	04/09/91
W	1423	50	8	5	2	4	4	3	23	01/17/92	08/06/91
P	1424	40	9	4	2	6	4	8	30	11/29/91	04/30/91
S	1424	20	12	6	2	8	8	10	38	01/03/92	04/09/91
W	1424	40	10	4	2	5	4	8	29	11/29/91	05/07/91
S	1425	20	12	6	2	8	8	10	38	10/18/91	01/22/91
S	1431	20	12	6	2	8	8	10	38	01/10/92	04/16/91
S	1432	20	12	6	2	8	8	10	38	12/20/91	03/26/91
P	1433	40	11	4	2	9	5	7	33	12/06/91	04/16/91
S	1433	20	12	6	2	8	8	10	38	11/29/91	03/05/91
P	1510	40	12	5	2	8	5	6	31	11/08/91	04/02/91
S	1510	20	12	5	2	8	5	6	31	11/08/91	04/02/91
P	1520	40	10	5	2	8	5	6	31	10/25/91	03/19/91
S	1520	20	12	5	2	8	5	6	31	10/25/91	03/19/91
P	1610	50	9	4	2	7	4	6	29	12/13/91	05/21/91
S	1610	20	12	5	2	8	5	6	31	11/08/91	04/02/91
P	1620	50	9	4	2	7	4	6	29	01/17/92	06/25/91

UNIT-STAGE SCHEDULE TABLE DATA PRINTOUT
Printed on 02/13/89 at 15:12:11

UNIT-STAGE TABLE DATA							
Dates Based on an Effective Contract Award Date of 06/02/89							
UNIT/ C-DATE		ST 20	30	40	50	60	65
=====		=====	=====	=====	=====	=====	=====
1110	Wks ACED:	148	151	148	153	156	160
	Duration:	3	4	5	2	4	6
10/15/91	Dates	04/03/92	04/24/92	04/03/92	05/08/92	05/29/92	06/26/92
1120	Wks ACED:	144	147	144	149	152	156
	Duration:	3	4	5	2	4	6
09/17/91	Dates	03/06/92	03/27/92	03/06/92	04/10/92	05/01/92	05/29/92
1130	Wks ACED:	142	146	142	148	151	156
	Duration:	4	4	6	2	5	6
09/10/91	Dates	02/21/92	03/20/92	02/21/92	04/03/92	04/24/92	05/29/92
1210	Wks ACED:	132	134	130	136	137	143
	Duration:	7	8	5	1	8	9
06/18/91	Dates	12/13/91	12/27/91	11/29/91	01/10/92	01/17/92	02/28/92
1220	Wks ACED:	131	135	131	137	139	143
	Duration:	4	4	6	2	4	9
06/25/91	Dates	12/06/91	01/03/92	12/06/91	01/17/92	01/31/92	02/28/92
1230	Wks ACED:	135	138	135	140	143	148
	Duration:	4	4	5	2	4	9
07/16/91	Dates	01/03/92	01/24/92	01/03/92	02/07/92	02/28/92	04/03/92
1310	Wks ACED:	127	130	127	133	134	140
	Duration:	8	9	5	1	2	8
04/23/91	Dates	11/08/91	11/29/91	11/08/91	12/20/91	12/27/91	02/07/92
1320	Wks ACED:	127	131	127	133	136	140
	Duration:	4	4	6	2	4	8
04/23/91	Dates	11/08/91	12/06/91	11/08/91	12/20/91	01/10/92	02/07/92
1330	Wks ACED:	131	135	131	137	140	144
	Duration:	4	4	6	2	4	8
05/21/91	Dates	12/06/91	01/03/92	12/06/91	01/17/92	02/07/92	03/06/92
1411	Wks ACED:	127	129	125	131	132	136
	Duration:	6	6	6	1	1	10
02/12/91	Dates	11/08/91	11/22/91	10/25/91	12/06/91	12/13/91	01/10/92
1412	Wks ACED:	125	127	123	129	130	134
	Duration:	6	6	6	1	1	9
01/22/91	Dates	10/25/91	11/08/91	10/11/91	11/22/91	11/29/91	12/27/91
1413	Wks ACED:	125	127	124	129	130	134
	Duration:	6	6	6	1	1	9
03/12/91	Dates	10/25/91	11/08/91	10/18/91	11/22/91	11/29/91	12/27/91
1414	Wks ACED:	133	133	130	135	137	139
	Duration:	3	3	6	1	2	5
04/23/91	Dates	12/20/91	12/20/91	11/29/91	01/03/92	01/17/92	01/31/92

EQUIPMENT DATA TABLE PRINTOUT

Printed on 01/15/89 at 14:58:25

SYSTEM NAME		DURATIONS											DATES		
EQUIPMENT NAME	EQSYM PO NR	T	R	V	E	V	V	E	M	T	S	W	PD C DAY	CD C DAY	INSTL DAY
EQUIP A DATE		S	F	B	V	P	C	V	F	S	H	H	PD A DAY	CD A DAY	HW A DAY
		P	Q	D	L	D	D	D	R	T	P	S			
AFFF DISTRIBUTN															
AFFF HOSE RACKS	AFHRK -	3	4	5	3	6	8	2	12	1	2	3	03/05/91	03/05/91	12/30/91
09/18/90													10/09/90	09/18/90	03/21/91
AFFF CONC PUMP	AFPMP -	4	4	5	4	7	9	3	26	3	3	3	03/05/91	06/18/91	12/06/91
09/18/90													09/18/90	12/11/90	10/01/90
AFFF PROPORTRNR	AFPRP -	2	3	5	2	4	5	1	25	2	3	3	03/05/91	06/18/91	12/06/91
10/30/90													10/30/90	01/29/91	12/17/90
AFFF CONC TANK	AFTNK -	3	4	5	2	3	6	3	12	2	3	3	03/05/91	03/29/91	11/29/91
11/02/90													11/06/90	11/02/90	02/18/91
AUX SW COOLING															
A/C COMPRESSORS	ASACC -	4	5	5	3	6	9	2	18	3	3	3	03/15/91	03/15/91	11/11/91
09/07/90													10/05/90	09/07/90	11/08/90
REFRIG COMPRPMP	ASCPM -	4	5	5	3	6	9	2	18	3	3	3	03/15/91	03/15/91	11/11/91
09/14/90													10/12/90	09/14/90	11/15/90
MSKRAIR COOLER	ASMAC -	2	3	5	4	4	6	2	12	2	4	3	03/15/91	03/15/91	11/11/91
10/05/90													10/26/90	10/05/90	01/17/91
MSKRAIR CLG PMP	ASMCP -	4	4	5	4	6	8	1	15	2	3	3	03/15/91	03/15/91	11/11/91
09/14/90													10/05/90	09/14/90	12/20/90
MSKROILCLRCOMP	ASMOC -	4	5	5	3	6	8	2	13	2	3	3	03/15/91	03/15/91	11/11/91
09/14/90													10/05/90	09/14/90	12/27/90
PRARYAIR COOLER	ASPAC -	2	3	5	4	4	6	2	12	2	4	3	03/15/91	03/15/91	11/11/91
10/12/90													11/02/90	10/12/90	01/24/91
PRARYAIR CLGPMP	ASPCP -	4	4	5	4	6	8	1	15	2	3	3	03/15/91	03/15/91	11/11/91
09/07/90													09/28/90	09/07/90	12/13/90
AUX SW PUMP	ASPMP -	4	4	5	4	6	8	1	15	2	3	3	03/15/91	03/15/91	11/11/91
09/14/90													10/05/90	09/14/90	12/20/90
PRAIROILCLRCOMP	ASPOC -	4	5	5	4	6	8	2	13	2	3	3	03/15/91	03/15/91	11/11/91
09/14/90													10/05/90	09/14/90	12/27/90
REFR COMP CLR	ASRCL -	2	3	5	4	6	8	2	16	2	3	3	03/15/91	03/15/91	11/11/91
09/28/90													10/19/90	09/28/90	12/20/90
REFRIG COMPRPMP	ASRCP -	4	4	5	4	6	8	2	19	3	2	3	03/15/91	03/15/91	11/11/91
09/14/90													10/05/90	09/14/90	11/15/90
STNDBY ASW PUMP	ASSTB -	4	4	5	4	6	8	1	15	2	3	3	03/15/91	03/15/91	11/11/91
09/14/90													10/05/90	09/14/90	12/20/90
COMPRESSED AIR															
HP AIR COMPRESR	CAHPC -	3	4	5	2	6	8	1	25	2	2	3	02/12/91	03/15/91	12/30/91
09/25/90													09/25/90	10/05/90	12/27/90
HP AIR FLASK	CAHPF -	2	3	5	2	0	3	1	5	1	2	3	02/12/91	03/15/91	11/11/91
11/20/90													11/20/90	11/23/90	05/23/91
HP AIR MANIFOLD	CAHPM -	3	4	5	3	1	3	1	8	2	2	3	02/12/91	03/15/91	11/11/91
10/23/90													10/23/90	11/02/90	04/04/91
CHILLED WATER															
COOLING COIL	CWCYL -	3	4	4	2	6	8	1	20	2	3	3	03/15/91	12/15/99	12/15/99
11/02/90													11/02/90	07/14/99	01/16/99
DRAIN & BALLAST															
ACTUATOR	DBACT -	3	4	5	3	4	5	1	12	2	3	3	03/15/91	03/15/91	01/31/92
10/19/90													11/02/90	10/19/90	05/06/91

EQUIPMENT - UNIT - STAGE TABLE DATA PRINTOUT
Printed on 01/15/89 at 15:02:22

SYS TYP	EQUIPMENT SYMBL	NAME	UNIT	STAGE	INSTALLATION DATE	UNIT "C" DATE
----	-----	-----	----	----	-----	-----
P	AFHRK	AFFF HOSERACKS	1421	50	12/30/91	03/15/91
P	AFHRK	AFFF HOSERACKS	1422	60	04/06/92	03/29/91
P	AFHRK	AFFF HOSERACKS	1433	60	02/07/92	03/05/91
P	AFHRK	AFFF HOSERACKS	2510	50	01/17/92	06/18/91
P	AFPMP	AFFF CONC PUMP	2510	40	12/06/91	06/18/91
P	AFPMP	AFFF CONC PUMP	2510	40	12/06/91	06/18/91
P	AFTNK	AFFF CONC TANK	1422	50	02/03/92	03/29/91
P	AFTNK	AFFF CONC TANK	1423	40	11/29/91	04/02/91
P	AFTNK	AFFF CONC TANK	2510	40	12/06/91	06/18/91
P	ASACC	A/C COMPRESSORS	1421	40	11/11/91	03/15/91
P	ASACC	A/C COMPRESSORS	1422	40	11/22/91	03/28/91
P	ASACC	A/C COMPRESSORS	1423	40	11/29/91	04/02/91
P	ASCPM	REFRIG COMPMP	1421	40	11/11/91	03/15/91
P	ASHAC	MSKRAIR COOLER	1421	40	11/11/91	03/15/91
P	ASHCP	MSKRAIR CLG PMP	1421	40	11/11/91	03/15/91
P	ASMOC	MSKROILCLRCONPR	1421	40	11/11/91	03/15/91
P	ASPAC	PRARYAIR COOLER	1421	40	11/11/91	03/15/91
P	ASPCP	PRARYAIR CLGMP	1421	40	11/11/91	03/15/91
P	ASPMP	AUX SW PUMP	1421	40	11/11/91	03/15/91
P	ASPOC	PRAIROILCLRCONPR	1421	40	11/11/91	03/15/91
P	ASRCL	REFR COMPR CLR	1421	40	11/11/91	03/15/91
P	ASRCP	REFRIG COMPMP	1421	40	11/11/91	03/15/91
P	ASSTB	STNDBY ASW PUMP	1421	40	11/11/91	03/15/91
P	CAHPC	HP AIR COMPRESR	1421	50	12/30/91	03/15/91
P	CAHPC	HP AIR COMPRESR	1422	50	02/03/92	03/29/91
P	CAHPF	HP AIR FLASK	1421	40	11/11/91	03/15/91
P	CAHPF	HP AIR FLASK	1422	40	11/22/91	03/29/91
P	CAHPM	HP AIR MANIFOLD	1421	40	11/11/91	03/15/91
P	CAHPM	HP AIR MANIFOLD	1422	40	11/22/91	03/29/91
P	CAHPM	HP AIR MANIFOLD	2400	40	02/07/92	07/30/91
P	DBACT	ACTUATOR	1421	60	02/24/92	03/15/91
P	DBACT	ACTUATOR	1422	60	04/06/92	03/29/91
P	DBACT	ACTUATOR	1423	60	01/31/92	04/02/91
P	DBAED	AUX EDUCTOR	1421	50	12/30/91	03/15/91
P	DBAED	AUX EDUCTOR	1422	50	02/03/92	03/29/91
P	DBAED	AUX EDUCTOR	1423	50	01/17/92	04/02/91
P	DBMED	MAIN EDUCTOR	1421	50	12/30/91	03/15/91
P	FMPMP	FIRE PUMP	1421	40	11/11/91	03/15/91
P	FMPMP	FIRE PUMP	1422	40	11/22/91	03/29/91
P	FMPMP	FIRE PUMP	1422	50	02/03/92	03/29/91
P	FMPMP	FIRE PUMP	1423	40	11/29/91	04/02/91
P	FMSTR	FIREPMP STRAINR	1421	40	11/11/91	03/15/91
P	FMSTR	FIREPMP STRAINR	1422	40	11/22/91	03/29/91
P	FMSTR	FIREPMP STRAINR	1423	40	11/29/91	04/02/91
P	HSSTG	STEERING GEAR	1610	50	12/13/91	04/02/91
P	PHMCL	MASKER COOLER	1422	50	02/03/92	03/29/91
P	PHMCP	MASKER COMPRSR	1422	50	02/03/92	03/29/91
P	PMPCCL	PRAIRE COOLER	1422	50	02/03/92	03/29/91
P	PMPCP	PRAIRIE COMPRSR	1433	50	01/17/92	03/05/91
P	PWBRP	BROM RECIRC PMP	1422	40	11/22/91	03/29/91
P	PWDST	DISTILLERS	1422	60	04/06/92	03/29/91
P	PWDST	DISTILLERS	1423	60	01/31/92	04/02/91

SYSTEM DEPENDENCY DATA TABLE PRINTOUT On 01/15/89 At 10:48:41

SYSTEMS			FINISH-FINISH LAGS				PHASE 2 START	
USER	PRVDR	DRVR	USR PH1	USR CLC	PRV PH2	USR PH3	"A" DATES	
			PRV PH1	PRV CLC	USR PH2	PRV PH3	PRVDR'S	USER'S
AF	SW	FM	2	4	2	2	07/24/90	06/26/90
AS	SW	FM	1	4	2	1	07/24/90	06/26/90
DB	SW	FM	3	5	2	2	07/24/90	06/19/90
FM	SW	-	1	2	2	3	07/24/90	07/10/90
PM	SW	FM	2	6	2	2	07/24/90	06/12/90
PW	CA	-	1	1	1	1	09/25/90	09/18/90
SF	SW	FM	2	4	2	2	07/24/90	06/26/90
SF	CA	PW	2	3	4	2	09/25/90	09/04/90
SF	CA	-	2	2	2	2	09/25/90	09/11/90

Figure A-12

DIAGRAM CURRENT/ACTUAL DATA TABLE CONTENT
Printed on 08/31/89 at 15:14:41

SYSTEM NAME	PHASE 1		CALCULATIONS		PHASE 2		PHASE 3	
	START	FINISH	START	FINISH	START	FINISH	START	FINISH
=====								
AFFF DISTRIBUTN								
Curr	05/05/89	05/16/89	05/20/89	06/14/89	06/17/89	10/18/89	10/21/89	12/07/89
Actl	06/09/89	06/23/89	06/23/89	-	-	-	-	-
=====								
AUX SW COOLING								
Curr	08/12/89	09/10/89	09/13/89	09/14/89	09/30/89	12/07/89	01/14/90	03/22/90
Actl	-	-	-	-	-	-	-	-
=====								
COMPRESSED AIR								
Curr	07/09/90	07/27/90	07/30/90	08/24/90	08/27/90	10/19/90	10/22/90	12/14/90
Actl	06/12/90	-	-	-	-	-	-	-
=====								
CHILLED WATER								
Curr	09/24/90	10/05/90	10/08/90	10/26/90	10/29/90	01/04/91	01/07/91	03/15/91
Actl	-	-	-	-	-	-	-	-
=====								
DRAIN & BALLAST								
Curr	-	-	-	-	-	-	-	-
Actl	-	-	-	-	-	-	-	-
=====								
FIREMAIN								
Curr	08/15/90	08/31/90	09/03/90	09/28/90	10/01/90	11/23/90	11/26/94	01/18/91
Actl	-	-	-	-	-	-	-	-
=====								
FIREMAIN								
Curr	-	-	-	-	-	-	-	-
Actl	-	-	-	-	-	-	-	-
=====								
HYDRAULIC STRG								
Curr	-	-	-	-	-	-	-	-
Actl	-	-	-	-	-	-	-	-
=====								
PRAIRIE MASKER								
Curr	-	-	-	-	-	-	-	-
Actl	-	-	-	-	-	-	-	-
=====								
POTABLE WATER								
Curr	05/20/89	05/31/89	06/03/89	06/28/89	07/01/89	09/20/89	09/23/89	12/12/89
Actl	-	-	-	-	-	-	-	-
=====								
SANITARY FLUSHG								
Curr	-	-	-	-	-	-	-	-
Actl	-	-	-	-	-	-	-	-
=====								
MAIN SW COOLING								
Curr	08/20/90	09/07/90	09/10/90	10/12/90	10/15/90	12/21/90	12/24/90	03/01/91
Actl	-	-	-	-	-	-	-	-

DIAGRAM SCHEDULE -

Based on Contract Award Date of 06/02/89
 Printed on 08/31/89 at 15:17:02

SYSTEM NAME	SHIPYARD DWG NR		OWNER'S DWG NR		PHASE ONE		PHASE TWO		PHASE THREE	
	START	FINISH	START	FINISH	START	FINISH	START	FINISH	START	FINISH
AFFF DISTRIBUTN	SYDNR XXXXXD		555-12345678D							
E					06/29/90	08/21/90	08/24/90	10/16/90		
L	05/18/90	05/29/90	06/01/90	06/26/90	12/28/90	02/19/91	02/22/91	04/19/91		
C	05/05/89	05/16/89	05/20/89	06/14/89	06/17/89	10/18/89	10/21/89	12/07/89		
A	06/09/89	06/23/89	06/23/89	-	-	-	-	-		
AUX SW COOLING	SYDNR YYYYYE		520-23456789E							
E					06/29/90	09/04/90	09/07/90	12/04/90		
L	04/27/90	05/22/90	05/25/90	06/26/90	12/24/90	03/01/91	03/04/91	06/03/91		
C	08/12/89	09/10/89	09/13/89	09/14/89	09/30/89	12/07/89	01/14/90	03/22/90		
A	-	-	-	-	-	-	-	-		
COMPRESSED AIR	-		-							
E					09/28/90	11/20/90	11/23/90	12/25/90		
L	08/10/90	08/28/90	08/31/90	09/25/90	12/07/90	01/29/91	02/01/91	03/08/91		
C	07/09/90	07/27/90	07/30/90	08/24/90	08/27/90	10/19/90	10/22/90	12/14/90		
A	06/12/90	-	-	-	-	-	-	-		
CHILLED WATER	444455023-12		999-6666-123A							
E					11/05/90	01/11/91	01/14/91	04/05/91		
L	10/01/90	10/12/90	10/15/90	11/02/90	12/24/90	03/01/91	03/04/91	05/27/91		
C	09/24/90	10/05/90	10/08/90	10/26/90	10/29/90	01/04/91	01/07/91	03/15/91		
A	-	-	-	-	-	-	-	-		
DRAIN & BALLAST	-		-							
E					06/22/90	08/28/90	08/31/90	11/20/90		
L	04/27/90	05/22/90	05/25/90	06/19/90	12/24/90	03/01/91	03/04/91	05/27/91		
C	-	-	-	-	-	-	-	-		
A	-	-	-	-	-	-	-	-		
FIREMAIN	-		-							
E					07/13/90	10/16/90	10/19/90	01/08/91		
L	05/25/90	06/12/90	06/15/90	07/10/90	11/16/90	02/19/91	02/22/91	05/17/91		
C	08/15/90	08/31/90	09/03/90	09/28/90	10/01/90	11/23/90	11/26/90	01/18/91		
A	-	-	-	-	-	-	-	-		
FIREMAIN	-		-							
E					07/13/90	10/16/90	10/19/90	01/08/91		
L	05/25/90	06/12/90	06/15/90	07/10/90	11/16/90	02/19/91	02/22/91	05/17/91		
C	-	-	-	-	-	-	-	-		
A	-	-	-	-	-	-	-	-		
HYDRAULIC STRG	560-60		560-34567890F							
E					12/03/90	01/04/91	01/07/91	02/08/91		
L	11/19/90	11/23/90	11/26/90	11/30/90	01/28/91	03/01/91	03/04/91	04/08/91		
C	-	-	-	-	-	-	-	-		
A	-	-	-	-	-	-	-	-		

DIAGRAM SCHEDULE -

Based on Contract Award Date of 06/02/89
 Printed on 06/30/89 at 15:33:18

	SYSTEM NAME		SHIPYARD DWG NR		OWNER'S DWG NR		PHASE ONE		PHASE TWO		PHASE THREE	
	START	FINISH	START	FINISH	START	FINISH	START	FINISH	START	FINISH	START	FINISH
	AUX SW COOLING		SYDNR YYYYYY		520-23456789E							
E					06/29/90	09/04/90	09/07/90	12/04/90				
L	04/27/90	05/22/90	05/25/90	06/26/90	12/24/90	03/01/91	03/04/91	06/03/91				
C	08/12/89	09/10/89	09/13/89	09/14/89	09/30/89	12/07/89						
A	-	-	-	-	-	-	-	-	-	-	-	-
	DRAIN & BALLAST											
E					06/22/90	08/28/90	08/31/90	11/20/90				
L	04/27/90	05/22/90	05/25/90	06/19/90	12/24/90	03/01/91	03/04/91	05/27/91				
C	-	-	-	-	-	-	-	-	-	-	-	-
A	-	-	-	-	-	-	-	-	-	-	-	-
	SANITARY FLUSHG											
E					06/29/90	09/04/90	09/07/90	11/13/90				
L	04/27/90	05/22/90	05/25/90	06/26/90	12/28/90	03/05/91	03/08/91	05/17/91				
C	-	-	-	-	-	-	-	-	-	-	-	-
A	-	-	-	-	-	-	-	-	-	-	-	-
	PRAIRIE MASKER											
E					06/15/90	08/07/90	08/10/90	10/02/90				
L	05/04/90	05/22/90	05/25/90	06/12/90	11/16/90	01/08/91	01/11/91	03/08/91				
C	-	-	-	-	-	-	-	-	-	-	-	-
A	-	-	-	-	-	-	-	-	-	-	-	-
	AFFD DISTRIBUTN		SYDNR XXXXXXD		555-12345678D							
E					06/29/90	08/21/90	08/24/90	10/16/90				
L	05/18/90	05/29/90	06/01/90	06/26/90	12/28/90	02/19/91	02/22/91	04/19/91				
C	05/05/89	05/16/89	05/20/89	06/14/89	06/17/89	10/18/89	10/21/89	12/07/89				
A	06/09/89	06/23/89	06/23/89	-	-	-	-	-	-	-	-	-
	FIREMAIN											
E					07/13/90	10/16/90	10/19/90	01/08/91				
L	05/25/90	06/12/90	06/15/90	07/10/90	11/16/90	02/19/91	02/22/91	05/17/91				
C	-	-	-	-	-	-	-	-	-	-	-	-
A	-	-	-	-	-	-	-	-	-	-	-	-
	FIREMAIN											
E					07/13/90	10/16/90	10/19/90	01/08/91				
L	05/25/90	06/12/90	06/15/90	07/10/90	11/16/90	02/19/91	02/22/91	05/17/91				
C	08/15/90	08/31/90	09/03/90	09/28/90	10/01/90	11/23/90	11/26/94	01/18/91				
A	-	-	-	-	-	-	-	-	-	-	-	-
	MAIN SW COOLING											
E					07/27/90	10/02/90	10/05/90	01/01/91				
L	05/25/90	06/19/90	06/22/90	07/24/90	11/02/90	01/08/91	01/11/91	04/12/91				
C	08/20/90	09/07/90	09/10/90	10/12/90	10/15/90	12/21/90	12/24/90	03/01/91				
A	-	-	-	-	-	-	-	-	-	-	-	-

UNIT COMPOSITE DRAWING SCHEDULE -

Based on a Contract Award Date of 06/02/89

Printed on 06/30/89 at 15:41:51

UNIT	ORIG SCHED	CURRENT EST		ACTUAL	
	FINISH	START	FINISH	START	FINISH
1110	10/15/91	-	10/01/91	-	-
1120	09/17/91	-	09/03/91	-	-
1130	09/10/91	-	08/28/91	-	-
1210	06/18/91	-	06/04/91	-	-
1220	06/25/91	-	06/11/91	-	-
1230	07/16/91	-	07/02/91	-	-
1310	04/23/91	-	04/09/91	-	-
1320	04/23/91	-	04/09/91	-	-
1330	05/21/91	-	05/07/91	-	-
1411	02/12/91	-	01/29/91	-	-
1412	01/22/91	-	01/15/91	-	-
1413	03/12/91	-	02/28/91	-	-
1414	04/23/91	-	04/09/91	-	-
1415	04/23/91	-	04/16/91	-	-
1421	03/15/91	-	04/12/91	-	-
1422	03/29/91	-	03/20/91	-	-
1423	04/02/91	-	03/20/91	-	-
1424	04/09/91	-	03/27/91	-	-
1425	01/22/91	-	01/15/91	-	-
1431	04/16/91	-	04/02/91	-	-
1432	03/26/91	-	03/12/91	-	-
1433	03/05/91	-	02/21/91	-	-
1510	04/02/91	-	03/19/91	-	-
1520	03/19/91	-	03/05/91	-	-
1610	04/02/91	-	03/19/91	-	-
1620	05/07/91	-	04/23/91	-	-
2100	11/26/91	-	11/12/91	-	-
2210	11/19/91	-	11/05/91	-	-
2310	06/04/91	-	05/21/91	-	-
2320	07/02/91	-	06/18/91	-	-
2330	06/18/91	-	06/04/91	-	-
2400	07/30/91	-	07/16/91	-	-
2510	06/18/91	-	06/04/91	-	-
2520	06/18/91	-	06/04/91	-	-

SYSTEM TYPE UNIT ASSEMBLY PROCESS SCHEDULE
 Based on a Contract Award Date of 06/02/89
 Printed on 06/30/89 at 11:16:34

UNIT	SYSTYPE	ASSEMBLY DRAWING NR.		FABRICATION DWG NR.		UAD		UFD		UFF		UFF	
		START	FINISH	START	FINISH	START	FINISH	START	FINISH	START	FINISH	START	FINISH
1421	P	1421-PI-40-A		1421-PF-40--									
Early:		04/01/91	06/07/91	04/22/91	05/31/91	06/17/91	07/05/91	07/22/91	09/13/91				
Late :		05/16/91	07/22/91	06/03/91	07/12/91	07/29/91	08/16/91	09/02/91	10/25/91				
Curr :		04/29/91	07/05/91	05/20/91	06/28/91	07/15/91	08/02/91	08/19/91	10/11/91				
Act :		-	-	-	-	-	-	-	-				
1422	P	1422-PI-30-B		1422-PF-30-C									
Early:		04/15/91	07/05/91	05/06/91	06/21/91	07/08/91	07/26/91	08/12/91	10/11/91				
Late :		06/20/91	09/09/91	07/08/91	08/23/91	09/09/91	09/27/91	10/14/91	12/13/91				
Curr :		06/03/91	08/23/91	06/24/91	08/09/91	08/26/91	09/13/91	09/30/91	11/13/91				
Act :		-	-	-	-	-	-	-	-				
1421	S	1421-SI-20-B		1421-SF-20-A									
Early:		04/01/91	06/21/91	04/22/91	06/14/91	07/01/91	07/19/91	08/05/91	09/27/91				
Late :		04/18/91	07/08/91	05/06/91	06/28/91	07/15/91	08/02/91	08/19/91	10/11/91				
Curr :		-	-	-	-	-	-	-	-				
Act :		-	-	-	-	-	-	-	-				
1422	S	1422-SI-20-A		1422-SF-20-B									
Early:		04/15/91	07/05/91	04/29/91	06/21/91	07/08/91	08/02/91	08/19/91	10/25/91				
Late :		05/02/91	07/22/91	05/13/91	07/05/91	07/22/91	08/16/91	09/02/91	11/08/91				
Curr :		-	-	-	-	-	-	-	-				
Act :		-	-	-	-	-	-	-	-				
1424	P	-		-									
Early:		04/26/91	06/25/91	05/10/91	06/18/91	07/05/91	07/30/91	08/16/91	10/08/91				
Late :		06/03/91	08/02/91	06/14/91	07/23/91	08/09/91	09/03/91	09/20/91	11/12/91				
Curr :		-	-	-	-	-	-	-	-				
Act :		-	-	-	-	-	-	-	-				
1412	P	-		-									
Early:		02/08/91	04/16/91	02/22/91	04/16/91	05/03/91	06/11/91	06/28/91	08/20/91				
Late :		04/29/91	07/05/91	05/10/91	07/02/91	07/19/91	08/27/91	09/13/91	11/05/91				
Curr :		-	-	-	-	-	-	-	-				
Act :		-	-	-	-	-	-	-	-				
1423	P	-		-									
Early:		04/19/91	07/09/91	05/03/91	06/25/91	07/12/91	08/20/91	09/06/91	10/29/91				
Late :		05/06/91	07/26/91	05/17/91	07/09/91	07/26/91	09/03/91	09/20/91	11/12/91				
Curr :		-	-	-	-	-	-	-	-				
Act :		-	-	-	-	-	-	-	-				
1411	W	-		-									
Early:		03/01/91	04/23/91	03/15/91	04/09/91	04/26/91	05/21/91	06/07/91	06/25/91				
Late :		07/29/91	09/20/91	08/09/91	09/03/91	09/20/91	10/15/91	11/01/91	11/19/91				
Curr :		-	-	-	-	-	-	-	-				
Act :		-	-	-	-	-	-	-	-				

EQUIPMENT SCHEDULES AND STATUS
Based on Contract Award Date of 06/02/89
Printed On 06/30/89 at 15:37:48

SYSTEM EQUIPMENT NAME	SYMBOL	PD NR.		PD AWARD	PD RECEIPT	CD RECEIPT
		TECH START	SPEC FINISH			
AFFF DISTRIBUTN AFFF HOSERACKS	AFHRK	-	-	-	-	-
Early Sched	06/29/90	07/17/90	09/25/90	01/29/91	02/12/91	
Late Sched	09/21/90	10/09/90	12/18/90	02/19/91	02/12/91	
Current Sched	10/16/89	11/03/89	12/15/89	02/16/90	03/02/90	
Actual	-	-	-	-	-	
AFFF CONC PUMP	AFPMP	-	-	-	-	-
Early Sched	06/29/90	07/24/90	10/09/90	02/19/91	03/05/91	
Late Sched	09/21/90	10/16/90	01/01/91	02/19/91	05/28/91	
Current Sched	10/16/89	11/10/89	01/15/90	03/02/90	03/16/90	
Actual	-	-	-	-	-	
AFFF PROPORTRNR	AFPRP	-	-	-	-	-
Early Sched	06/29/90	07/10/90	09/18/90	02/19/91	02/26/91	
Late Sched	11/02/90	11/13/90	01/22/91	02/19/91	05/28/91	
Current Sched	-	-	-	-	-	
Actual	-	-	-	-	-	
AFFF CONC TANK	AFTNK	-	-	-	-	-
Early Sched	06/29/90	07/17/90	09/18/90	02/15/91	03/08/91	
Late Sched	11/05/90	11/23/90	01/25/91	02/19/91	03/08/91	
Current Sched	07/22/89	08/09/89	10/04/89	11/15/89	11/29/89	
Actual	-	-	-	-	-	
AUX SW COOLING A/C COMPRESSORS	ASACC	-	-	-	-	-
Early Sched	06/29/90	07/24/90	10/09/90	02/01/91	02/22/91	
Late Sched	09/10/90	10/05/90	12/21/90	03/01/91	02/22/91	
Current Sched	-	-	-	-	-	
Actual	-	-	-	-	-	
REFRIG COMPRPMP	ASCPM	-	-	-	-	-
Early Sched	06/29/90	07/24/90	10/02/90	02/01/91	02/22/91	
Late Sched	09/17/90	10/12/90	12/21/90	03/01/91	02/22/91	
Current Sched	-	-	-	-	-	
Actual	-	-	-	-	-	
MSKRAIR COOLER	ASMAC	-	-	-	-	-
Early Sched	06/29/90	07/10/90	10/02/90	02/08/91	02/22/91	
Late Sched	10/08/90	10/19/90	01/11/91	03/01/91	02/22/91	
Current Sched	-	-	-	-	-	
Actual	-	-	-	-	-	
MSKRAIR CLG PMP	ASMCP	-	-	-	-	-
Early Sched	06/29/90	07/24/90	10/09/90	02/08/91	02/22/91	
Late Sched	09/17/90	10/12/90	12/28/90	03/01/91	02/22/91	
Current Sched	-	-	-	-	-	
Actual	-	-	-	-	-	