

**AFRL-SN-WP-TP-2006-117**

**MEASUREMENT OF THE  
PROPAGATION CONSTANT OF  
SURFACE WAVES ON A PERIODIC  
ARRAY (PREPRINT)**



**Dan S. Janning**

**MAY 2006**

**Approved for public release; distribution is unlimited.**

**STINFO COPY**

**This work has been submitted to Antenna Measurement Techniques Association (AMTA) for publication in the AMTA 2005 Proceedings. This is a work of the U.S. Government and is not subject to copyright protection in the United States.**

**SENSORS DIRECTORATE  
AIR FORCE RESEARCH LABORATORY  
AIR FORCE MATERIEL COMMAND  
WRIGHT-PATTERSON AIR FORCE BASE, OH 45433-7320**

# REPORT DOCUMENTATION PAGE

*Form Approved*  
OMB No. 0704-0188

The public reporting burden for this collection of information is estimated to average 1 hour per response, including the time for reviewing instructions, searching existing data sources, gathering and maintaining the data needed, and completing and reviewing the collection of information. Send comments regarding this burden estimate or any other aspect of this collection of information, including suggestions for reducing this burden, to Department of Defense, Washington Headquarters Services, Directorate for Information Operations and Reports (0704-0188), 1215 Jefferson Davis Highway, Suite 1204, Arlington, VA 22202-4302. Respondents should be aware that notwithstanding any other provision of law, no person shall be subject to any penalty for failing to comply with a collection of information if it does not display a currently valid OMB control number. **PLEASE DO NOT RETURN YOUR FORM TO THE ABOVE ADDRESS.**

<b>1. REPORT DATE (DD-MM-YY)</b> May 2006		<b>2. REPORT TYPE</b> Conference Paper Preprint		<b>3. DATES COVERED (From - To)</b> 05/01/2004 – 05/01/2006	
<b>4. TITLE AND SUBTITLE</b> MEASUREMENT OF THE PROPAGATION CONSTANT OF SURFACE WAVES ON A PERIODIC ARRAY (PREPRINT)				<b>5a. CONTRACT NUMBER</b> In-house	
				<b>5b. GRANT NUMBER</b>	
				<b>5c. PROGRAM ELEMENT NUMBER</b> N/A	
<b>6. AUTHOR(S)</b> Dan S. Janning				<b>5d. PROJECT NUMBER</b> 7622	
				<b>5e. TASK NUMBER</b> 11	
				<b>5f. WORK UNIT NUMBER</b> 0D	
<b>7. PERFORMING ORGANIZATION NAME(S) AND ADDRESS(ES)</b> Reference Systems and Analysis Branch (AFRL/SNRR) RF Sensors Technology Division Sensors Directorate Air Force Research Laboratory, Air Force Materiel Command Wright-Patterson AFB, OH 45433-7320				<b>8. PERFORMING ORGANIZATION REPORT NUMBER</b> AFRL-SN-WP-TP-2006-117	
<b>9. SPONSORING/MONITORING AGENCY NAME(S) AND ADDRESS(ES)</b>  Sensors Directorate Air Force Research Laboratory Air Force Materiel Command Wright-Patterson Air Force Base, OH 45433-7320				<b>10. SPONSORING/MONITORING AGENCY ACRONYM(S)</b>  AFRL-SN-WP	
				<b>11. SPONSORING/MONITORING AGENCY REPORT NUMBER(S)</b> AFRL-SN-WP-TP-2006-117	
<b>12. DISTRIBUTION/AVAILABILITY STATEMENT</b> Approved for public release; distribution is unlimited.					
<b>13. SUPPLEMENTARY NOTES</b> PAO Case Number: AFRL/WS 05-1648, 13 Jul 2005.  This work has been submitted to Antenna Measurement Techniques Association (AMTA) for publication in the AMTA 2005 Proceedings.  This report contains color.					
<b>14. ABSTRACT</b> A technique is proposed to measure the propagation constant of surface waves on a periodic dipole array using a waveguide simulator. Due to the slow wave characteristic of surface waves, it is necessary to present an evanescent waveguide mode to the plane containing the elements. Two techniques for sensing the element currents are outlined.					
<b>15. SUBJECT TERMS</b> frequency selective surfaces, arrays					
<b>16. SECURITY CLASSIFICATION OF:</b>			<b>17. LIMITATION OF ABSTRACT:</b> SAR	<b>18. NUMBER OF PAGES</b> 10	<b>19a. NAME OF RESPONSIBLE PERSON (Monitor)</b> Joshua Radcliffe
<b>a. REPORT</b> Unclassified	<b>b. ABSTRACT</b> Unclassified	<b>c. THIS PAGE</b> Unclassified			

Standard Form 298 (Rev. 8-98)  
Prescribed by ANSI Std. Z39-18

# MEASUREMENT OF THE PROPAGATION CONSTANT OF SURFACE WAVES ON A PERIODIC ARRAY

Dan S. Janning

Air Force Research Laboratory, AFRL/SNRR Bldg 620, 2241 Avionics Circle  
Wright Patterson AFB, Ohio 45433-7302

## ABSTRACT

A technique is proposed to measure the propagation constant of surface waves on a periodic dipole array using a waveguide simulator. Due to the slow wave characteristic of surface waves, it is necessary to present an evanescent waveguide mode to the plane containing the elements. Two techniques for sensing the element currents are outlined.

**Keywords:** Frequency Selective Surfaces, Arrays

## 1.0 Introduction

Whereas studies of periodic surfaces initially focus upon elements in an infinite planar array environment [1-3] the effects of truncation are usually a secondary concern [4]. In a large truncated array, the currents on the interior elements are typically very close to those in the infinite case- the so-called Floquet currents- and only a few columns near the edges exhibit some perturbation. Nevertheless, there can exist, at lower frequencies, surface waves which propagate across the array and render the currents throughout dramatically different from the Floquet currents of the corresponding infinite array. Simulations have been performed to predict the propagation constant and the amplitude of surface waves excited on finite arrays [5]. The former parameter can be determined through infinite array analysis. The amplitude of the surface waves must be determined through analysis of truncated arrays.

Up to now, little or no experimental work has been performed to verify the values derived from the simulations described above. Measurements have been performed on linear dipole arrays [6]. Here, it is proposed that a waveguide simulator be employed to experimentally determine the propagation constant of surface waves traveling on an array of periodically spaced dipoles. Waveguide simulators have the advantage of simulating a fully infinite array, removing edge perturbations that must be accounted for in a real array. Supporting layers of dielectric can also be incorporated into the measurement apparatus.

Since waveguide simulators model infinite arrays, they cannot be used to measure truncation-dependent effects, such as the magnitude of surface waves excited at the edge of a finite periodic surface or the reflection of a

surface wave that encounters an edge. As in all waveguide simulator measurements, at a given frequency, scan is obtained at one specific angle. This implies that surface waves should only be detectable at a single frequency.

## 2.0 Background

The propagation constant of surface waves on a periodic surface can be derived by calculating the source-free solutions from the method of moments (MoM) formulation [5]. This defines the mode where the array guides the surface waves. These waves are considered "source-free" on a lossless infinite array in the sense that once excited, they can travel an indefinite distance without attenuation- that is, the source of the wave can be located an arbitrarily large distance away.

In the MoM model of the infinite, planar dipole array, the current on each element is expanded into one or more modes. The array is assumed to be uniformly excited, either by an external plane wave, or voltage generators on each element. Thus all elements of the array have the same voltages and currents aside from a known phase taper, and it is necessary only to model the current on a single element of the array, the so-called reference element. A reaction integral equation is set up to enforce the condition of zero electric fields on the center axis of each dipole. This leads to the standard matrix equation

$$\mathbf{V} = [\mathbf{Z}]\mathbf{I} . \quad (1)$$

If sources are not present or are removed to infinity, then the voltage vector  $\mathbf{V}$  contains all zeroes and a non-trivial solution for the expansion mode currents in  $\mathbf{I}$  is possible only if

$$\det [\mathbf{Z}] = 0. \quad (2)$$

Passive dipole arrays are treated in this paper. It is advantageous, however, to examine the variation of the driving point impedance of an active array with scan angle. A delta gap voltage generator is placed at the center of each element, so that the voltage vector contains one non-zero entry. The driving point impedance is then the ratio of that voltage to the terminal current. Since the terminal current is one of the entries of  $\mathbf{I}$  in (1), application of Cramer's rule demonstrates that the zeroes of the scan impedance coincide with the zeroes of the determinant of  $[\mathbf{Z}]$ . In other words, the source-free

**PREPRINT**

modes of the passive array can be determined by finding the zeroes of the driving point impedance of the active array. The use of generators, has the additional advantage of allowing scan into so-called “imaginary space”, where the impedance is purely reactive and no power is carried away from the array. As explained below, surface waves propagate in imaginary space.

The array under consideration is shown in Figure 1. The geometry supports surface waves traveling parallel to the x- axis, so the direction of scan is in the H-plane, as shown in the drawing. Rather than use the angle  $\phi$  as an independent variable, it is more convenient to use the propagation constant relative to the free space propagation constant.

$$s_x = \beta_x / \beta_0 \quad (3)$$

This quantity is equivalent to the direction cosine along the x axis of the plane wave radiated by the array. The relative propagation constant is related to the scan angle by the equation  $s_x = \cos\phi$ . However, the relative phase difference between adjacent columns is  $\psi = 2\pi s_x D_x / \lambda$ , so that unique phasing is obtained for values of  $s_x$  in the range  $-\lambda/2/D_x \leq s_x \leq \lambda/2/D_x$ . Therefore, when the inter-column spacing,  $D_x$ , is less than one-half wavelength, it is possible to excite the array such that

$$|s_x| > 1. \quad (4)$$

In fact, since surface waves are slow waves that attenuate exponentially away from the supporting structure, the magnitude of their relative propagation constant is always greater than one. Since the direction cosines of a propagating plane wave are of less than unit magnitude, it is convenient to excite the array with voltage generators instead of a plane wave when determining surface wave propagation constants.

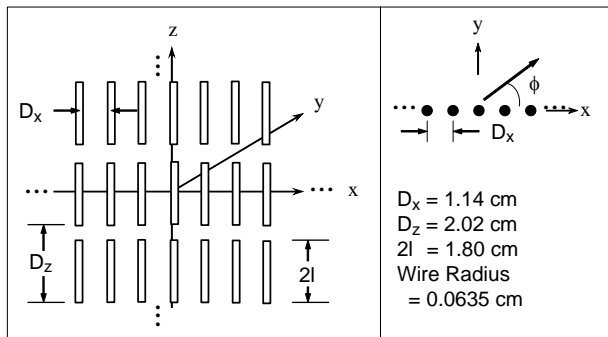

Figure 1- Array Geometry

In Figure 2 the self-impedance is plotted as a function of  $s_x$  at 5.4 GHz. The impedance, denoted  $Z_{11}$ , is shown for only for positive values of  $s_x$ , since, due to symmetry,  $Z_{11}(-s_x) = Z_{11}(s_x)$ . For improved accuracy, three expansion modes were used for the dipole currents. When  $s_x = 0$ , the main beam of the array is directed broadside. As  $s_x$  increases, the main beam approaches end-fire and the impedance becomes more capacitive. Just before the endfire condition is reached, the curve begins to turn rapidly back to the left and the impedances become purely imaginary at  $s_x = 1$ . No power is carried away from the array beyond this point. As the phase difference is increased beyond the endfire condition, the curves quickly descend the imaginary axis to minus infinity and return along the positive imaginary axis. The imaginary part then decreases until a minimum value is reached at  $s_x = \lambda/(2D_x)$ . At this point each column is  $180^\circ$  out of phase with its neighbors.

The imaginary part passes through 0 at  $s_x = s_{x0} = 1.21$ . This is the propagation constant for surface waves. If the frequency is raised above 5.4 GHz, the minimum reactance, attained at  $s_x = \lambda/(2D_x)$ , is pushed higher, eventually crossing zero at 6.75 GHz. Above this frequency, the impedance has no zeroes and surface waves do not propagate.

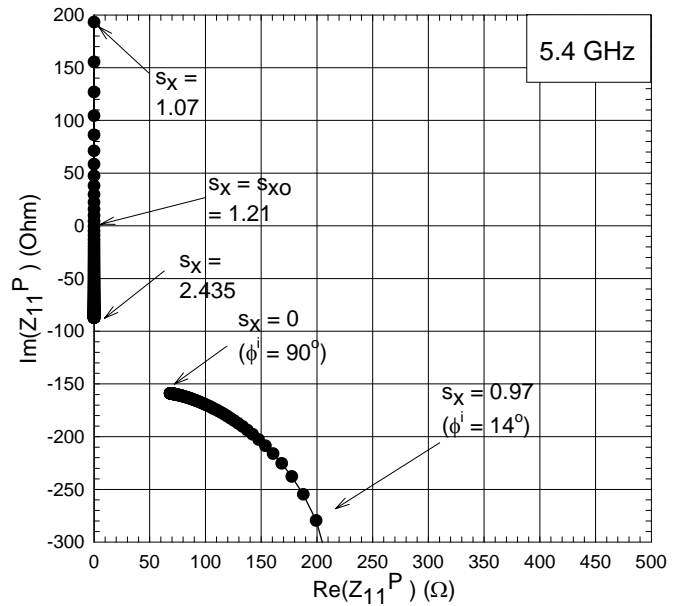
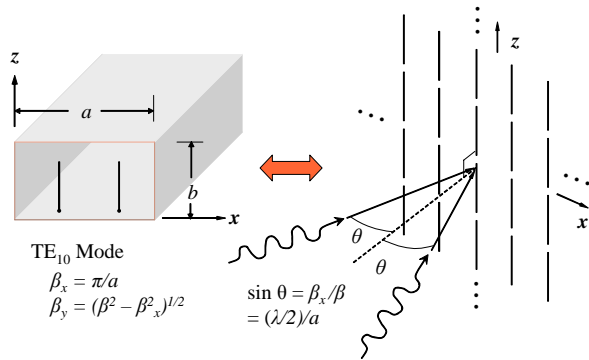

Figure 2- The self impedance of an infinite planar array of dipoles as the phase between successive columns is changed varied between 0 and 180 Degrees.



**Figure 3- Diagram showing the relationship between the propagation constant of the lowest order waveguide mode and the angle of scan of the simulated array.**

### 3.0 Description of the Measurement Technique

It is now proposed that a waveguide simulator be used to experimentally determine the propagation constant of surface waves. Waveguide simulators were introduced in the 1960's as a means of determining the reflection coefficient of an infinite array [7]. Antenna elements, or portions thereof, are positioned inside a waveguide such that the ensemble of images through the walls of the waveguide form the complete infinite planar array. The fields of the dominant waveguide mode image to multiple plane waves whose interference patterns are such that nulls in the tangential electric field are formed in the planes where the waveguide walls are located.

Figure 3 shows the equivalence between a simulator excited in the TE<sub>10</sub> mode and a planar array excited by a pair of plane waves. The waveguide dimensions are related to the interelement spacings by  $a = 2D_x$  and  $b = D_z/2$ . The monopoles in the waveguide are half as long as the dipoles in the array. The angle  $\theta$  in Figure 3 denotes the direction of propagation of the incident plane waves and is the complement of the angle  $\phi$  shown in Figure 1.

Since  $s_x = \beta_x/\beta$  must be greater than unity to enable surface wave propagation, it follows that the waveguide must be excited with an evanescent TE<sub>10</sub> mode in order to observe surface wave-related effects. This creates a problem in how to sense the fields near the monopole elements. Two solutions are presented in Figure 4. In one case, the simulator couples to larger waveguides on the input and output sides. The larger waveguides support a propagating TE<sub>10</sub> mode. In the second case, a

slot along the broad wall of the reduced waveguide allows a small probe to be placed inside the waveguide, as in a slotted-line measurement of voltage standing wave ratio.

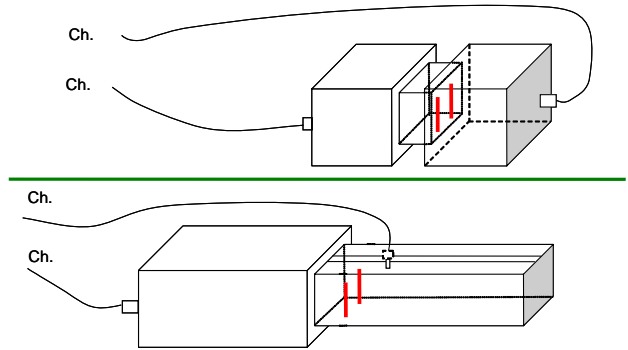

**Figure 4- Two methods of sensing the fields of monopoles in a waveguide that supports only evanescent modes: (Top) Allow the reduced-size waveguide to couple to a larger waveguide which permits a propagating wave, and (Bottom) Insert a probe in a slot along the broad wall of the reduced waveguide.**

A sweep of the frequency, in either case, will excite the equivalent of the surface wave when the waveguide propagation constant is equal to the surface wave propagation constant. In Figure 5 the waveguide propagation constant and the calculated surface wave constant are plotted versus frequency. The surface wave condition in this case occurs at 5.4 GHz. At the onset of surface waves, the array impedance, as shown in Figure 2, approaches zero for the lossless array. In the waveguide, therefore, the currents should peak at the critical frequency, limited by the tolerances in construction of the simulator and the ohmic loss in the metal. Because the fields are evanescent, the probe- or alternatively the larger section of waveguide- must be placed close enough to the array to sense the fields.

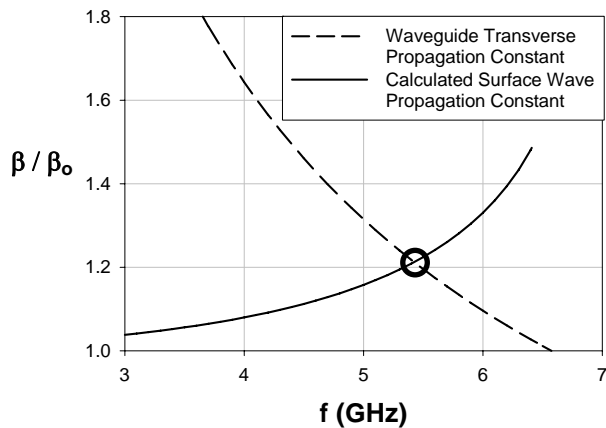

**Figure 5- Surface wave propagation constant (from method of moment calculation) and waveguide propagation constant.**

#### 4. Summary

A method of measuring the propagation constant of surface waves on periodic dipole arrays using a waveguide simulator has been presented. This technique, which involves presenting an evanescent waveguide mode to the representative monopoles, models the infinite array, for which computer simulation results are readily available. For a given configuration, the surface wave propagation constant can be measured at a single frequency. This technique can be applied to arrays having complicated elements embedded in layers of dielectric material.

#### 5. REFERENCES

- [1] B.A. Munk, "Frequency Selective Surfaces: Theory and Design," John Wiley & Sons, Inc., 1998.
- [2] T.K. Wu, "Frequency Selective Surface and Grid Array," John Wiley & Sons, Inc., 1995.
- [3] R.C. Hansen, "Phased Array Antennas," John Wiley & Sons, Inc., 1998.
- [4] B.A. Munk, "Finite Antenna Arrays and FSS," John Wiley & Sons, Inc., 2003.
- [5] D.S. Janning and B.A. Munk, "Effects of surface waves on the currents of truncated periodic arrays," IEEE Trans. Antennas Propagat., AP-50(9):1254-1265, Sep 2002.

[6] E.K. Damon, "The near fields of long end-fire dipoles," IRE Trans. Antennas Propagat., AP-10:511-523, Sep 1962.

[7] P.W. Hannan and M.A. Balfour, "Simulation of a phased-array antenna in a waveguide," IEEE Trans. Antennas Propagat., AP-13(3):342-353, May 1965.

#### 6. ACKNOWLEDGMENTS

The author wishes to thank Dr. Leo Kempel for reviewing the manuscript.