



NATIONAL STEEL AND SHIPBUILDING COMPANY

LEAPFROG TECHNOLOGY TO
STANDARDIZE EQUIPMENT
AND SYSTEM INSTALLATION

UNIVERSITY OF NEW ORLEANS SUBCONTRACT

NSRP 0537 PROJECT SP-6-95-2 Sept. 1999

SECTION NO. 8 — PRODUCT MODELING CRITERIA AND DEMONSTRATION

PRINCIPAL INVESTIGATOR:

DOMINIC BURNS

SENIOR ENGINEER

NATIONAL STEEL AND SHIPBUILDING COMPANY

ADDITIONAL INVESTIGATOR:

JOHN HOPKINSON

PRESIDENT

VIBTECH, INC.

UNIVERSITY OF NEW ORLEANS

NEW ORLEANS, LA 7014

Report Documentation Page

Form Approved
OMB No. 0704-0188

Public reporting burden for the collection of information is estimated to average 1 hour per response, including the time for reviewing instructions, searching existing data sources, gathering and maintaining the data needed, and completing and reviewing the collection of information. Send comments regarding this burden estimate or any other aspect of this collection of information, including suggestions for reducing this burden, to Washington Headquarters Services, Directorate for Information Operations and Reports, 1215 Jefferson Davis Highway, Suite 1204, Arlington VA 22202-4302. Respondents should be aware that notwithstanding any other provision of law, no person shall be subject to a penalty for failing to comply with a collection of information if it does not display a currently valid OMB control number.

| | | | | | |
|--|------------------------------------|--|--|----------------------------------|---------------------------------|
| 1. REPORT DATE SEP 1999 | 2. REPORT TYPE N/A | 3. DATES COVERED - | | | |
| 4. TITLE AND SUBTITLE The National Shipbuilding Research Program, Leapfrog Technology to Standardize Equipment and Systems Installations, Section No.8-Product Modeling Criteria and Demonstration | | 5a. CONTRACT NUMBER | | | |
| | | 5b. GRANT NUMBER | | | |
| | | 5c. PROGRAM ELEMENT NUMBER | | | |
| 6. AUTHOR(S) | | 5d. PROJECT NUMBER | | | |
| | | 5e. TASK NUMBER | | | |
| | | 5f. WORK UNIT NUMBER | | | |
| 7. PERFORMING ORGANIZATION NAME(S) AND ADDRESS(ES) Naval Surface Warfare Center CD Code 2230-Design Integration Tower Bldg 192, Room 128 9500 MacArthur Blvd Bethesda, MD 20817-5700 | | 8. PERFORMING ORGANIZATION REPORT NUMBER | | | |
| 9. SPONSORING/MONITORING AGENCY NAME(S) AND ADDRESS(ES) | | 10. SPONSOR/MONITOR'S ACRONYM(S) | | | |
| | | 11. SPONSOR/MONITOR'S REPORT NUMBER(S) | | | |
| 12. DISTRIBUTION/AVAILABILITY STATEMENT Approved for public release, distribution unlimited | | | | | |
| 13. SUPPLEMENTARY NOTES | | | | | |
| 14. ABSTRACT | | | | | |
| 15. SUBJECT TERMS | | | | | |
| 16. SECURITY CLASSIFICATION OF: | | | 17. LIMITATION OF ABSTRACT SAR | 18. NUMBER OF PAGES 10 | 19a. NAME OF RESPONSIBLE PERSON |
| a. REPORT unclassified | b. ABSTRACT unclassified | c. THIS PAGE unclassified | | | |

| |
|--------------------------|
| TABLE OF CONTENTS |
|--------------------------|

| | |
|--|------------|
| 8 PRODUCT MODELING CRITERIA/ATTRIBUTES & DEMONSTRATE..... | 8-1 |
| STANDARDS SELECTION..... | 8-1 |
| ENGINEERING ANALYSIS SPREADSHEET | 8-1 |
| INPUT BOX..... | 8-1 |
| AVAILABLE SCANTLINGS | 8-4 |
| APPLICATION OF PARAMETERS TO MODEL..... | 8-6 |
| FINAL DESIGN..... | 8-6 |

8 PRODUCT MODELING CRITERIA/ATTRIBUTES & DEMONSTRATE

This section describes and outlines the processes related to the design of Equipment Installations. The various Engineering and design tools developed in the previous sections and the methods associated with them will be described here. This section will attempt to relay a practical example of the basic application of the tools. The result of this described exercise should result in an Equipment Installation that has been through a cognizant process of calculation, validation, product modeling, and final design. The consequent design will be for an installation that is more producible in terms of materials, methods, and manhours.

STANDARDS SELECTION

Based on the ship functionality and scantling plan, an applicable standard mounting method and foundation is chosen and validated. The primary driver for the standards determination will be to support the Build Strategy for the shipyard for the particular contract.

For example, a typical crude oil tanker will most probably have a need for a pipe rack on the weather deck. The Build Strategy for this tanker might address producibility issues as they relate to certain facilities and timelines. Therefore, the different options for above deck pipe racks should be qualified.

ENGINEERING ANALYSIS SPREADSHEET

In order to validate a chosen standard and to develop an acceptable scantling plan for the Equipment Installation, the Engineering Analysis Spreadsheet is used as a tool to calculate dimensional requirements for the standard and scantling in process.

A spreadsheet has been developed to aid designers in determining the required scantling for the most common scenarios. These are single run hangers, single run hangers with bracing, racking systems with legs and structural attachments, and goal post racking systems with variable number of legs. These scenarios can be calculated using different configurations. These are forward and aft runs supported horizontally, athwartship runs supported horizontally, vertical runs mounted to longitudinal and athwartship bulkheads.

This spreadsheet determines the minimum section modulus and defaults to the required scantling. The scantling which can be chosen should reflect the raw material stock carried by the particular shipyard.

In the past there was no simple and consistent manner to determine scantling sizes. What came from that was over designed racking systems. A comparison was done between previous racking system designs and the racking systems selected by the program. This revealed that previous designs were over-designed with bracing that was not required.

The spreadsheet ensures that the scantlings selected are adequate without being overly conservative. Pipe Rack Spreadsheet Summary Sheet

Spreadsheet Summary

The racksf.xls spreadsheet was developed to assist in the selection of pipe racks scantlings for a variety of situations. Although many configurations are covered, some unique installations will have to be analyzed separately. The sheet consists of an input box, output box, a scantling chart, calculation section and several drawings. An attempt was made to create a product that is user friendly and easily updated if different criteria is to be used. The following is a line by line description of the spreadsheet.

INPUT BOX

Allowable Stress (psi) - This is the user defined maximum allowable stress in the pipe rack scantlings. This value is based on the scantling material. A commonly used value for steel is 34000 psi. Adjustments in this figure can produce varying factors of safety. (i.e. 17000 psi would create a 'factor of safety' of 2)

SECTION 8: PRODUCT MODELING CRITERIA AND DEMONSTRATION
LEAPFROG TECHNOLOGY TO STANDARDIZE EQUIPMENT & SYSTEM INSTALLATIONS

of Pipes (#) - This value can range any where from 1 to 15 pipes. If necessary, the chart can be altered to accommodate additional pipes. This would require adding additional rows to the pipe charts in both the input box and calculation box. The total weight line in the calculation box would also change to reflect the added rows. In a double tier situation, it would be necessary to run two different calculations. The first calculation would be for the outer tiers rack and legs. The second calculation would be for the inner tier rack and legs. For the second calculation it would be necessary to add the weight of the outer tier as an additional weight.

Standoff (in) - This is the distance the pipes are away from the structure or simply the leg length.

Length of Rack (in) - This is the width of the rack or the length of the pipe supporting scantling. In the cantilever case, there is only rack and no leg.

Gz, Gx, Gy - These are G force inputs to the to the pipe rack. The G-load chart indicates proper orientations. The values are a function of location in the ship and ships motions.

of Legs (#) - Simply the number of legs the rack has. This does not include attachments to ship structure.

of Structural Attachments (#) - Simply the number of attachments to the ship structure. This value should not include legs.

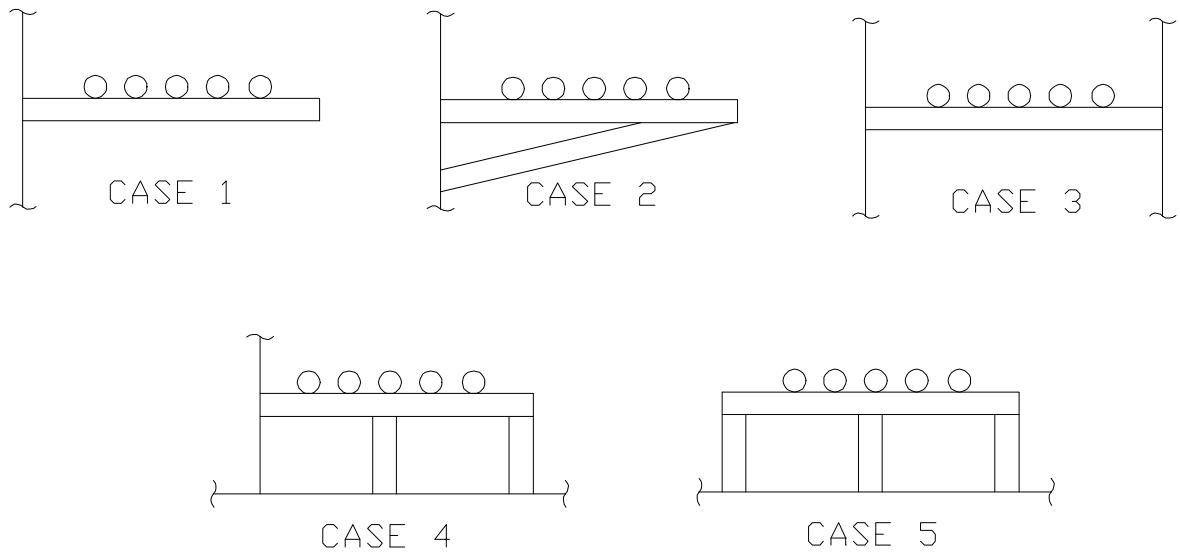

*THIS PAGE LEFT BLANK FOR INSERTION OF SCANTLING
SELECTION SPREADSHEET (INPUT -- see additional download)*

NSRP 0537 PROJECT 6-95-2

SECTION 8: PRODUCT MODELING CRITERIA AND DEMONSTRATION
LEAPFROG TECHNOLOGY TO STANDARDIZE EQUIPMENT & SYSTEM INSTALLATIONS

AVAILABLE SCANTLINGS

| | RACK | LEG | | RACK | LEG |
|----------------------|-------------|-----------|---------------------|--------|--------|
| ANGLE | SM | SM | CHANNELS | SM | SM |
| 1 X 1 X 1/8 | N/A | N/A | RTD1.624X.625X14GA | N/A | N/A |
| RTD 12 GA ANGLE | N/A | N/A | 1-1/4 X 1/2 X 1.0 # | N/A | N/A |
| 1 X 1 X 1/4 | N/A | N/A | RTD1.624X.625X3/16 | N/A | N/A |
| 1-1/4 X 1-1/4 X 3/16 | N/A | N/A | 2 X 1 X 2.32 # | N/A | N/A |
| 1-1/2 X 1-1/2 X 1/8 | N/A | N/A | 3 X 1-5/8 X 6.0 # | N/A | N/A |
| RTD 3/16 ANGLE | N/A | N/A | 4 X 1-5/8 X 7.25 # | N/A | N/A |
| 1-1/2 X 1-1/2 X 1/4 | N/A | N/A | 5 X 1-3/4 X 9.0 # | N/A | N/A |
| 2 X 2 X 1/4 | N/A | N/A | 6 X 2 X 10.5 # | N/A | N/A |
| 2 X 2 X 3/8 | N/A | N/A | 8 X 2-1/4 X 11.5 # | 8.140 | N/A |
| 2-1/2 X 2-1/2 X 5/16 | N/A | N/A | 6 X 3-1/2 X 15.3 # | 8.368 | N/A |
| 3 X 3 X 1/4 | N/A | N/A | 10 X 1-1/2 X 8.4 # | 8.909 | N/A |
| 3 X 3 X 3/8 | N/A | N/A | 8 X 3 X 18.7 # | 11.000 | N/A |
| 4 X 3 X 1/4 | N/A | N/A | 9 X 2-1/2 X 15.0 # | 11.300 | N/A |
| 4 X 3-1/2 X 5/16 | N/A | N/A | 12 X 1-1/2 X 10.6 # | 13.715 | 13.715 |
| 4 X 3 X 3/8 | N/A | N/A | 10 X 3-1/2 X 25.3 # | 18.200 | 18.200 |
| 5 X 3-1/2 X 5/16 | N/A | N/A | 12 X 3 X 20.7 # | 21.500 | 21.500 |
| 4 X 4 X 1/2 | N/A | N/A | 13 X 4 X 35.0 # | 37.106 | 37.106 |
| 5 X 3-1/2 X 3/8 | N/A | N/A | | | |
| 6 X 4 X 5/16 | N/A | N/A | | | |
| 6 X 3-1/2 X 3/8 | N/A | N/A | | | |
| 6 X 4 X 3/8 | N/A | N/A | | | |
| 6 X 4 X 1/2 | N/A | N/A | | | |
| 7 X 4 X 3/8 | N/A | N/A | | | |
| 7 X 4 X 1/2 | 5.810 | N/A | | | |
| 8 X 4 X 1/2 | 7.490 | N/A | | | |
| 9 X 4 X 1/2 | 9.340 | N/A | | | |
| | LEG | | | | |
| | PIPE | | | | |
| | | SM | | | |
| 1" SCH 80 | | N/A | | | |
| 1-1/2" SCH 80 | | N/A | | | |
| 2" SCH 80 | | N/A | | | |
| 2-1/2" SCH 80 | | N/A | | | |
| 3" SCH 80 | | N/A | | | |
| 4" SCH 80 | | N/A | | | |
| 5" SCH 80 | | N/A | | | |
| 6" SCH 80 | | N/A | | | |
| 8" SCH 80 | | 24.514 | | | |
| 10" SCH 80 | | 45.552 | | | |
| 12" SCH 80 | | 74.526 | | | |
| 14" SCH 80 | | 98.188 | | | |

SECTION 8: PRODUCT MODELING CRITERIA AND DEMONSTRATION
LEAPFROG TECHNOLOGY TO STANDARDIZE EQUIPMENT & SYSTEM INSTALLATIONS

| | |
|---------------------------------|---------------------|
| OUTPUT TANKER MAIN RACK | |
| RACK DATA | |
| | |
| RACK LENGTH (IN) | 216 |
| RACK REQD SM (IN ³) | 5.533 |
| | |
| ANGLE | 7 X 4 X 1/2 |
| ANGLE SM (IN ³) | 5.810 |
| ANGLE I (IN ⁴) | 26.7 |
| ANGLE FREQ (HZ) | 1.89 |
| | |
| CHANNEL | 8 X 2-1/4 X 11.5 # |
| CHANNEL SM (IN ³) | 8.140 |
| CHANNEL I (IN ⁴) | 32.56 |
| CHANNEL FREQ (HZ) | 2.09 |
| | |
| LEG DATA | |
| | |
| LEG LENGTH (IN) | 82.00 |
| LEG REQD SM | 12.603 |
| | |
| ANGLE | #N/A |
| ANGLE SM (IN ³) | 0.000 |
| ANGLE I (IN ⁴) | #N/A |
| ANGLE FREQ (HZ) | #N/A |
| | |
| CHANNEL | 12 X 1-1/2 X 10.6 # |
| CHANNEL SM (IN ³) | 13.715 |
| CHANNEL I (IN ⁴) | 82.29 |
| CHANNEL FREQ (HZ) | 3.54 |
| | |
| PIPE | 8" SCH 80 |
| PIPE SM (IN ³) | 24.514 |
| PIPE (IN ⁴) | 105.716 |
| PIPE FREQ (HZ) | 4.02 |

APPLICATION OF PARAMETERS TO MODEL

Based on the parameters validated by the Engineering Analysis Spreadsheet, a model of the foundation for the Equipment Installation is created and/or applicable dimensions applied to that model. At this point, the Equipment Installation foundation has become a product model, such that Production Information attributes are included as part of the model. This will enable automated Production Information to be created. From this point, similar repeatable products can be assigned to appropriate work stations or other facilities used by the shipyard for construction and assembly.

Sketch of pipe support

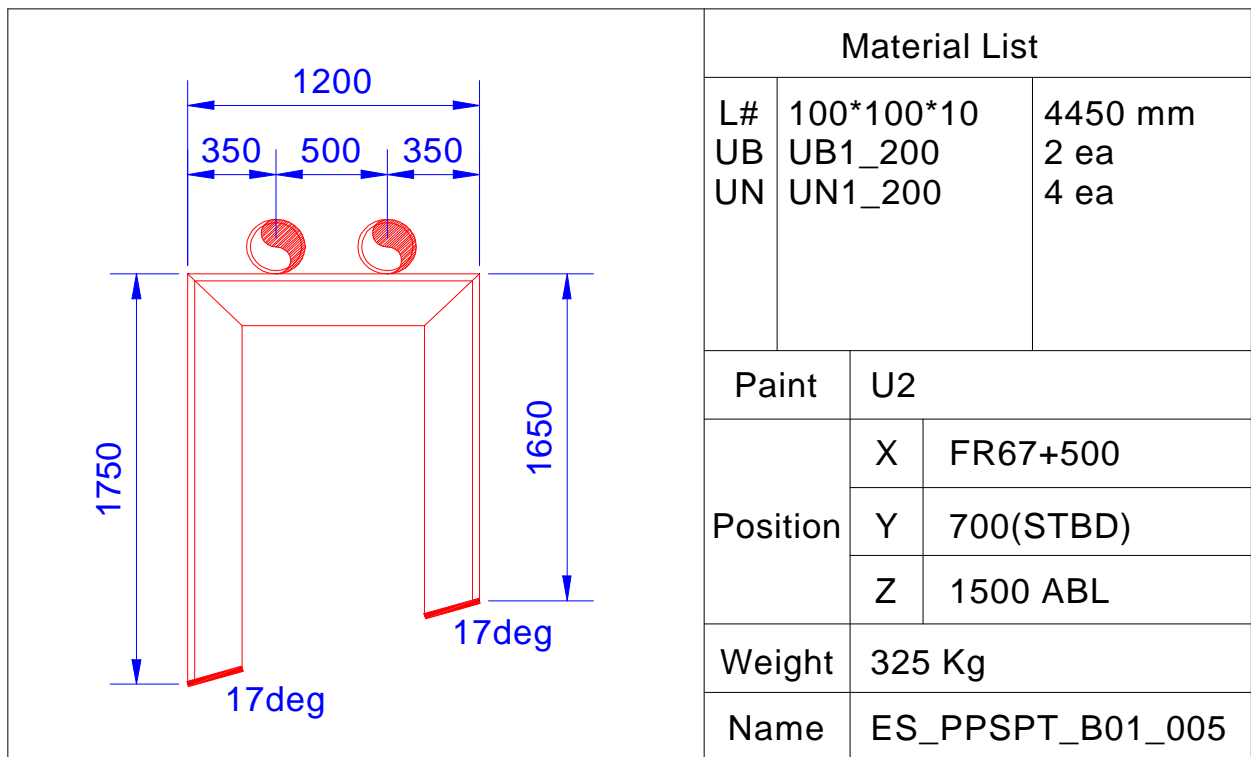

FINAL DESIGN

At this point, the design team should have a valid product model to apply to the final design. The model will provide the information necessary to provide production information. The advantages now included as an integral part of the production information are as follows:

- Automated Layout of Hangers and Foundations

SECTION 8: PRODUCT MODELING CRITERIA AND DEMONSTRATION
LEAPFROG TECHNOLOGY TO STANDARDIZE EQUIPMENT & SYSTEM INSTALLATIONS

The final arrangement model will provide location information for the layout of hangers and foundations. The location points will be included in the NC information that goes to the steel plate burning machines. The burning machines are capable of marking locating point on the steel. These locating marks can then be used to install the hangers and foundations. The method of placing the locating points will be dependent on the materials to be installed.

For example, in the case of hangers and foundations where weld pads are required, such as on the weather deck for a tanker, the weld pads are designed to have standard markings or notches that are used to line up with the location markings created with the automated burning machines.

- Automated Hanger and Foundation Sketches

The model will also have the information to provide shop information to fabricate hangers and foundations with a high degree of accuracy. This automated foundation sketching will be similar to pipe spooling software and applications already being used.

The production information created from the intelligent model will have the following attributes:

- Automated material lists

Each sketch will have all the materials and attributes of the model(s) to automatically produce a parts list relative to each sketch.

- Neat cutting of hangers

Materials used for hangers, such as steel angle, can be cut to accurate dimensions.

This will eliminate "cut to suit" operations in the field. In order to increase throughput in the field or on the ship, the focus for field operations will be installation rather than fabrication. Fabrication is best performed in shops under controlled conditions and proper tools and facilities.

Finally, the product models can be managed hierarchically to support interim product development, design, planning, fabrication, and assembly. The resulting units are in support of ship functional zones and arrangements.

