

SHIP PRODUCTION COMMITTEE  
FACILITIES AND ENVIRONMENTAL EFFECTS  
SURFACE PREPARATION AND COATINGS  
DESIGN/PRODUCTION INTEGRATION  
HUMAN RESOURCE INNOVATION  
MARINE INDUSTRY STANDARDS  
WELDING  
INDUSTRIAL ENGINEERING  
EDUCATION AND TRAINING

August 1990  
NSRP 0320

# **THE NATIONAL SHIPBUILDING RESEARCH PROGRAM**

## **1990 Ship Production Symposium**

### **Paper No. 6A-2: Large Scale Processing Machinery for Fabrication of Composite Hulls and Superstructure**

U.S. DEPARTMENT OF THE NAVY  
CARDEROCK DIVISION,  
NAVAL SURFACE WARFARE CENTER

# Report Documentation Page

*Form Approved*  
*OMB No. 0704-0188*

Public reporting burden for the collection of information is estimated to average 1 hour per response, including the time for reviewing instructions, searching existing data sources, gathering and maintaining the data needed, and completing and reviewing the collection of information. Send comments regarding this burden estimate or any other aspect of this collection of information, including suggestions for reducing this burden, to Washington Headquarters Services, Directorate for Information Operations and Reports, 1215 Jefferson Davis Highway, Suite 1204, Arlington VA 22202-4302. Respondents should be aware that notwithstanding any other provision of law, no person shall be subject to a penalty for failing to comply with a collection of information if it does not display a currently valid OMB control number.

1. REPORT DATE <b>AUG 1990</b>	2. REPORT TYPE <b>N/A</b>	3. DATES COVERED <b>-</b>			
4. TITLE AND SUBTITLE <b>The National Shipbuilding Research Program, 1990 Ship Production Symposium, Paper No. 6A-2: Large Scale Processing Machinery for Fabrication of Composite Hulls and Superstructure</b>		5a. CONTRACT NUMBER			
		5b. GRANT NUMBER			
		5c. PROGRAM ELEMENT NUMBER			
6. AUTHOR(S)		5d. PROJECT NUMBER			
		5e. TASK NUMBER			
		5f. WORK UNIT NUMBER			
7. PERFORMING ORGANIZATION NAME(S) AND ADDRESS(ES) <b>Naval Surface Warfare Center CD Code 2230-Design Integration Tools Bldg 192, Room 128 9500 MacArthur Blvd, Bethesda, MD 20817-5700</b>		8. PERFORMING ORGANIZATION REPORT NUMBER			
9. SPONSORING/MONITORING AGENCY NAME(S) AND ADDRESS(ES)		10. SPONSOR/MONITOR'S ACRONYM(S)			
		11. SPONSOR/MONITOR'S REPORT NUMBER(S)			
12. DISTRIBUTION/AVAILABILITY STATEMENT <b>Approved for public release, distribution unlimited</b>					
13. SUPPLEMENTARY NOTES					
14. ABSTRACT					
15. SUBJECT TERMS					
16. SECURITY CLASSIFICATION OF:			17. LIMITATION OF ABSTRACT <b>SAR</b>	18. NUMBER OF PAGES <b>21</b>	19a. NAME OF RESPONSIBLE PERSON
a. REPORT <b>unclassified</b>	b. ABSTRACT <b>unclassified</b>	c. THIS PAGE <b>unclassified</b>			

## DISCLAIMER

These reports were prepared as an account of government-sponsored work. Neither the United States, nor the United States Navy, nor any person acting on behalf of the United States Navy (A) makes any warranty or representation, expressed or implied, with respect to the accuracy, completeness or usefulness of the information contained in this report/manual, or that the use of any information, apparatus, method, or process disclosed in this report may not infringe privately owned rights; or (B) assumes any liabilities with respect to the use of or for damages resulting from the use of any information, apparatus, method, or process disclosed in the report. As used in the above, "Persons acting on behalf of the United States Navy" includes any employee, contractor, or subcontractor to the contractor of the United States Navy to the extent that such employee, contractor, or subcontractor to the contractor prepares, handles, or distributes, or provides access to any information pursuant to his employment or contract or subcontract to the contractor with the United States Navy. ANY POSSIBLE IMPLIED WARRANTIES OF MERCHANTABILITY AND/OR FITNESS FOR PURPOSE ARE SPECIFICALLY DISCLAIMED.

# THE NATIONAL SHIPBUILDING RESEARCH PROGRAM'S

## 1990 SHIP PRODUCTION SYMPOSIUM

Preparing for the 21st Century:  
Focusing on Productivity and Quality Management

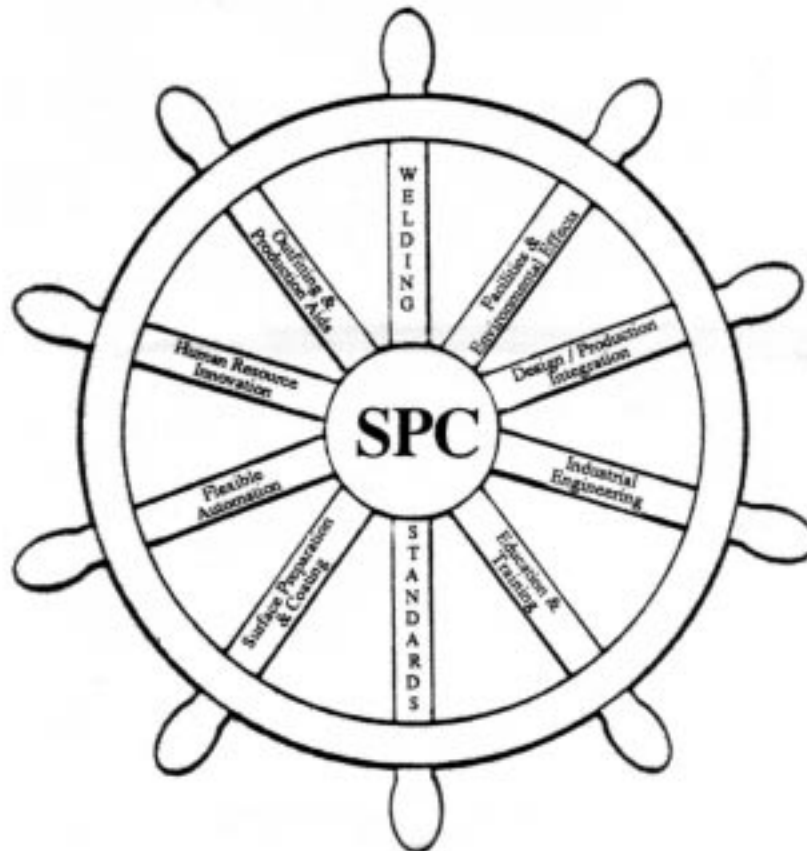

August 22-24, 1990  
Pfister Hotel  
Milwaukee, Wisconsin

SPONSORED BY THE SHIP PRODUCTION COMMITTEE  
AND HOSTED BY THE GREAT LAKES AND RIVERS SECTION OF  
THE SOCIETY OF NAVAL ARCHITECTS AND MARINE ENGINEERS





# Large Scale Processing Machinery for Fabrication of Composite Hulls and Superstructure

6A-2

John F. Raymer, Visitor, Venus-Gusmer, Kent, WA

## ABSTRACT

Large scale mechanical systems for impregnating and positioning composite materials are now permitting efficient manufacturing of composite hulls to 60 meters (200 ft) and greater. Recreational, commercial, and military vessels fabricated from composite materials are gaining acceptance around the world; however, processing of thermosetting resins and fiber reinforcements in quantities exceeding 90,000 kg (200,000 lbs) per unit presents a new set of challenges to production engineers responsible for maintaining quality control. Impregnation systems are currently being used at several mine-hunter production shipyards world-wide. Large-to-medium sized recreational yachts are also in production with impregnation systems. This paper will review some past and current impregnator installations, the selection process used for choosing the systems, and production engineering factors.

## INTRODUCTION

In recent years, the use of composite materials for fabrication of hulls and superstructures for mine counter-measure vessels (MKM), mine-hunter counter-measures (MHC), and minesweeper hunters (MSH) has been fully accepted by naval designers. Advantages of composites over steel have been well documented in numerous tests and include the abilities of surviving multiple explosion shocks while maintaining a low magnetic signature. Peripheral advantages of composite materials include superior resistance to corrosion, very low maintenance, ease of repair, rapid production schedules, and an excellent strength-to-weight ratio, which allows novel hull designs to be utilized

## REVIEW OF THE TECHNOLOGY

While fabrication of hulls and superstructures with steel is documented by an extensive body of knowledge gathered through years of experience, composite structures engineers do not have this body of knowledge available for reference. As the plastics industry as a whole evolves at a pace much faster than the metals industry, composite hull technology is also evolving at a rapid pace. While standards for composite or steel military vessels are often set through the same bureaucratic procedures, a problem sometimes exists when military specifications do not

reflect the current state of technology. Even with this technology lag, composite-built MCM vessels are out-performing their wood or steel counterparts in every way.

## Early Technology

Some of the early production experiments in composite MCM vessels were conducted in the United Kingdom during the construction of the *HMS Wilton in the* 1960's. In these early phases, conventional boatbuilding technology typically included hand-mixing of chemicals and application by paintbrush. Using "hand lay-up" methods to produce vessels of this size and complexity had never been attempted before, and the shortcomings soon became apparent. With the encouragement of the British Navy, a project was launched to develop large-scale mechanized equipment for processing glass fibers and impregnating them with polyester resins. Scheduling did not permit an extensive program, however, and this early equipment was abandoned after some limited success.

During this time frame, testing was being conducted in the United States for the development of mechanized lamination equipment. This technology evolved into a product currently available and in use in the world market. The large glass-fiber reinforced plastic panels (FRP/GRP) industry in North America provided a financial base to justify a long-range research and development project.

## Barge Covers

The first large-scale commercial success with mechanized impregnation equipment **took** place along the Mississippi River transport corridor. Commercial opportunities opened for fabrication of fiberglass reinforced barge covers as steel barge covers were rapidly damaged by impact and corrosion. These barge covers offered advantages of increasing cubic yards of grain that could be loaded into a single barge. An additional 100 tons of grain could be loaded in each barge through the use of an arched fiberglass cover configuration, allowing a rapid payback on the purchase.

At the peak of this production cycle, over 75 barge covers were produced in a single day at facilities owned by Xerxes-Proform in St. Paul, Louisville, and Paducah,

Kentucky. The demand for fiberglass barge covers became so great that it is reported that over 10% of all fiberglass rovings consumed in the U.S. were processed through the five impregnators installed in these facilities. In order to meet the demand for product, Proform purchased the Kaiser Glass Facility in Seguin, Texas to begin weaving and knitting operations .

### Evolution of the Process

During the 1970's, interest in composite MCM vessels began to expand and several vessels were constructed in Europe. During development of equipment for the barge cover projects in North America, it was found that precise pneumatic control systems were necessary to allow draping woven materials in the tight corners and sharp radii of stair steps and hat sections. This motion-control technology was ideally suited for fabrication of MCM vessels with stringent military standards. The Italian Navy settled on composite vessels as the standard method of construction after a series of rigorous tests. Equipment was exported from the United States to Italy for a series of highly successfully composite MCM programs.

### ADVANTAGES OF MECHANIZATION

When fabricating with composites, a major determining factor in the control of product quality is the fact that the material itself is actually blended and compounded on-site by skilled or semi-skilled laborers. This is not the case with steel: steel materials are fabricated in raw material production situations with numerous quality-control systems closely monitoring the process.

During the fabrication of composite hulls, materials must be brought together, metered, thoroughly mixed, and de-aerated by a team of fabricators. This is radically different from construction of hulls and superstructures with steel products.

Early experiences with composite fabrication of military vessels were conducted with hand-mixing methods or machine mixing with small-scale spray-gun equipment. While many successes were reported, many quality control problems began to arise that were not easily solvable.

While there were extensive training programs in place to allow welders to achieve a high-quality welding bead (inspected with x-ray technology), there were no such formal programs in place for training of composite laminators. This shortcoming manifested itself as a series of quality control problems in early attempts at fabricating composite MCM vessels.

The successful implementation of large-scale machinery in the Italian programs made apparent the tremendous advantage and versatility of centralizing the compounding, mixing, and metering technologies within a single large machine. Through the use of a single machine, it became possible to assign a small team of skilled technicians to maintain, operate, and monitor the

processing of the many tons of polyester used to impregnate the woven fiberglass.

### Air-Void Content

The key issue in quality control programs for composite MCM vessels is the air content of the laminate as it affects the wetted surfaces of the glass fibers. Early quality control methods established in the United Kingdom concentrated heavily on air-voids as the primary method of monitoring quality. This philosophy was based upon the obvious loss of physical properties that could occur if glass fibers were allowed to remain dry within a laminate, thereby disconnecting the fibers from the physical structure of the matrix. It was determined at the time that "less air means more strength" to the point of counting microscopic bubbles occurring within a cubic centimeter of laminate.

After this standard was firmly entrenched, further analysis determined that air voids were critical only when they prevented surface wetting of glass fibers. It was later found that small air voids falling within the resin matrix, and not contacting fiber surface areas, were not detrimental to physical properties by any significant factor. Because specifications followed by the industry were predicated upon traditional materials such as steel, the time required to review established standards for composites has been much more lengthy than the rate of the expansion of scientific knowledge within the plastics industry.

Because it is theoretically possible to hand-laminate a laboratory sample having a lower air-void content than is possible by machine, the growth of large-scale mechanized equipment has been limited to markets not directly impacted by the standards established by the British Navy. New technology is rapidly bringing the air-void content of impregnator-produced laminations closer to that achievable in laboratory conditions. However, this gap may never be completely closed due to the difference in scale between laboratory samples and the samples obtained from large-scale machinery operating at over 1000 pounds per hour.

### REVIEW OF IMPREGNATOR TECHNOLOGY

Early attempts in the U.K. at large-scale mechanization of the impregnation process involved the use of a controlled flat puddle of material through which the glass was pulled. This early technology has since evolved in the United States to a process involving two nip rollers controlling a pool of catalyzed material on either side of the glass fiber (figure 1). An additional set of rubber rollers is sometimes used to feed glass through the nip rollers (as well as preventing the glass from being pulled through by its own weight as it drops to the mold). This technology has since been utilized by shipyards in Italy, the U.K. and Korea as a standard operating method.

Impregnator technology has improved the quality control possible with composite materials and also has reduced labor requirements to 25% of that required with

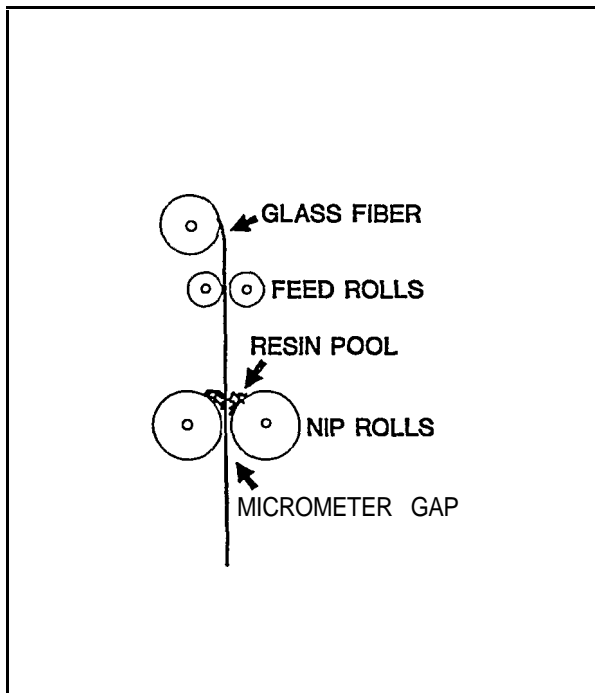

Figure 1. Impregnator Material Path

spray-gun or hand lamination technology. Motion control systems for accurate placement of material have completed the equipment package, to permit fabrication of MCM vessels at a much faster pace than steel fabrication technology has permitted

### NEW TECHNOLOGY

World patents have recently been filed describing a radical new approach to Impregnation technology. Previous four-roll Impregnator designs have succeeded in reducing air-void content well below the threshold required to achieve uniform fiber wetting; however, some variation in fiber volume content occurred when the machine was stopped for a significant length of time (allowing resin to further wet the glass fibers and saturate through “wicking”). A machine operated at full linear throughput would usually have a lower fiber volume content than a machine which was intermittently stopped and started. Without a skillful crew, this situation could result in some variation of resin content (although quality was still far better than hand-lamination allowed).

Another shortcoming of the four-roll design has been the effect of saturating resin into the glass fibers from both sides of the glass simultaneously, thereby trapping some air within the glass material as the resin meets in the center (figure 2). Even so, the air-void content was still significantly less than that achievable by hand or spray gun when dry glass was laid against a dry mold and a mist of resin was applied over the top of the glass. Achieving high-speed mechanical saturation of the glass without trapping air was the problem to be addressed. Patents have recently been applied for describing a system which moves resin through the glass reinforcement from a single

direction, thereby allowing air to move in front of the resin “wave.” This new technology allows significant improvement in air-void content to levels approaching those possible in laboratory conditions with hand squeegees.

### New Impregnator Technology

By a reconfiguration of the conventional impregnator design (patent applied for), it has become possible to move resin through the glass fiber from one direction only (figure 3). The pool of resin is restricted to one side of the glass fabric as it moves through the sets of Impregnator rollers. A pressure roller is then used to create pressure exerted from the resin-impregnated side of the glass. This tensioning device creates a majority of the impregnation effect in this design.

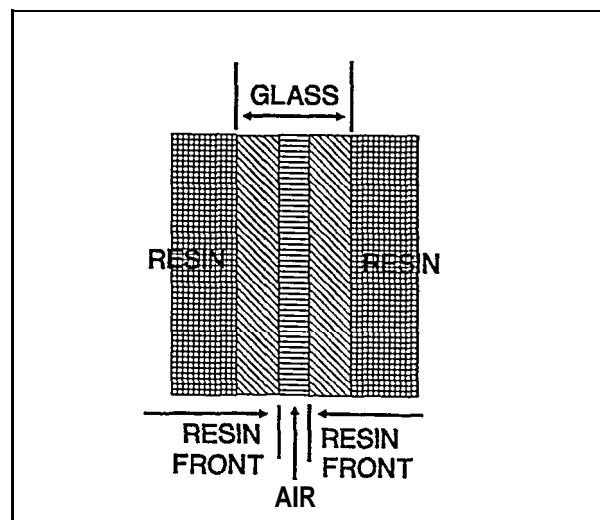

Figure 2. Four-roll Impregnator

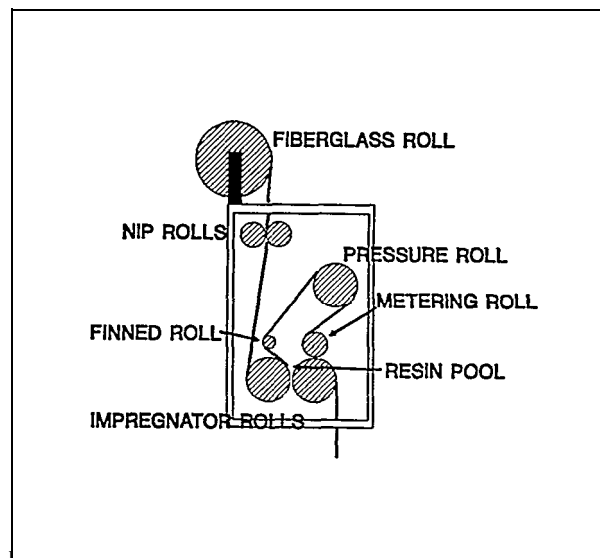

Figure 3. Seven-roll Material Path

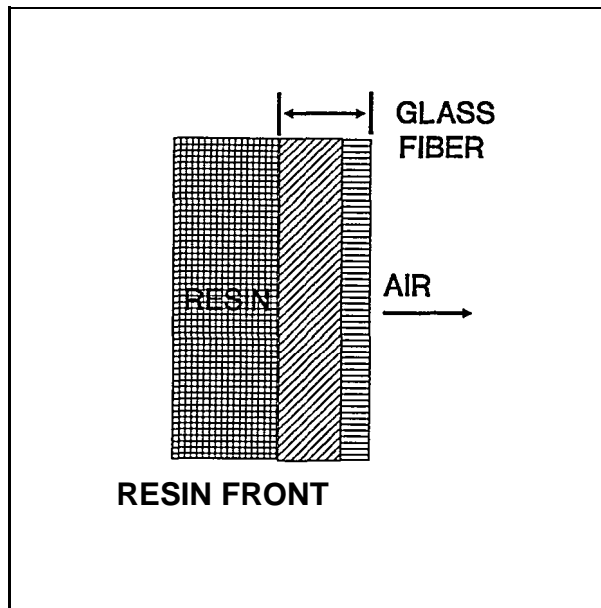

Figure 4. seven-roll Impregnator

By the time the material is returned to the pool for a final wetting, nearly 100% of entrapped air has been expelled through the outside surface of the material (figure 4). An additional saturation by the resin occurs on a cycle of the material through a final micrometer-controlled gap, which determines the final thickness of the wet material (therefore, the fiber-volume-fraction as well). Existing technology is utilized to control the depth of the resin pool automatically with a self-purging liquid level controller.

With air-void content recently being called into question as a major contributor to osmotic blistering, further reductions in air void content can only be beneficial to the ultimate integrity of laminate intended for marine service.

An immediate benefit is also seen during fabrication. A reduction of air voids reduces time requirements for applying multiple layers of laminate and removing air from the material.

## OSMOTIC BLISTERING

As more fiberglass vessels are sold throughout the world yearly, the aggregate hours of composite laminate exposure to marine environments increases. The question of osmotic blistering has become a major topic of discussion within the naval architecture community. Osmotic blistering is easily reproduced with hot water testing in laboratory conditions; however, the actual factors contributing to blistering in a marine environment are still subject to discussion. It appears that a number of factors are contributing to osmotic blistering, with poorly mixed catalyst and dry fiberglass being two of the leading culprits.

Laminate samples constructed with either too much or too little catalyst will always result in a decrease of the time required to exhibit blistering. Laboratory experiments

also reveal a rapid degeneration of laminates that are constructed with air-voids lying along the surfaces of individual fibers (creating a channel for moisture wicking). Large air-voids also create a site for **moisture to gather** while collecting additional ions to initiate an osmosis process.

Some other factors called into question as contributors to osmotic blisters have been: (1) raw drops of MEKP catalyst overshooting the resin spray fan in external mixing spray equipment; (2) excessively long curing (without abrading) prior to further lamination; (3) insufficient curing before exposure to the marine environment; (4) attempts at production of laminates with extremely high fiber-volume-fractions (resulting in unwetted glass fiber surfaces).

Mechanized production of composite laminates is an obvious means of controlling poor techniques. Impregnation machinery allows the use of centralized metering and mixing pumps, which closely control catalyst-to-resin ratios without intervention by semi-skilled laborers. In the past, contamination of central resin sources has sometimes been a problem in production of MCM vessels. Semi-skilled laborers have even been known to return catalyzed resin to bulk holding tanks to "avoid wasting resin." Over-catalyzation of the resin to allow "working faster" is also a serious problem where manual labor is relied upon for compounding composite laminates.

## MOTION CONTROL SYSTEMS

A primary factor to be addressed by the production engineer is a system for moving the impregnation machine to any point within the mold, at any axis and at any elevation. The primary technology available today for motion control of impregnation systems is described as follows.

### Bridge-Crane Impregnator

The overhead bridge-crane has been proven for years as a rapid and efficient means of moving large loads within an industrial area. By adapting this technology to the Bridge-Crane Impregnator (with some improvements), it becomes possible to move the machine on a single horizontal plane to any point within the lamination area. By further mounting the impregnator machine on a rotating turret, it becomes possible to approach the mold surface at any vector required (figure 5). Although variable speed electric motors or hydraulic systems may be used to achieve these movements, pneumatic systems are more commonly used due to their high reliability, ease of maintenance, and acceleration control. Pneumatic motors are typically used to drive the bridge itself north and south with the carriage on the bridge driven east and west (with an additional motor driving the turret in a 360-degree rotation). Another set of controls (possibly operated by another operator) is used to increase and decrease the rate of linear travel of the reinforcement through the machine. Resin flow rate may also be visually monitored within the pool of the nip rollers, or automatic liquid level control devices may be installed (also pneumatically operated).

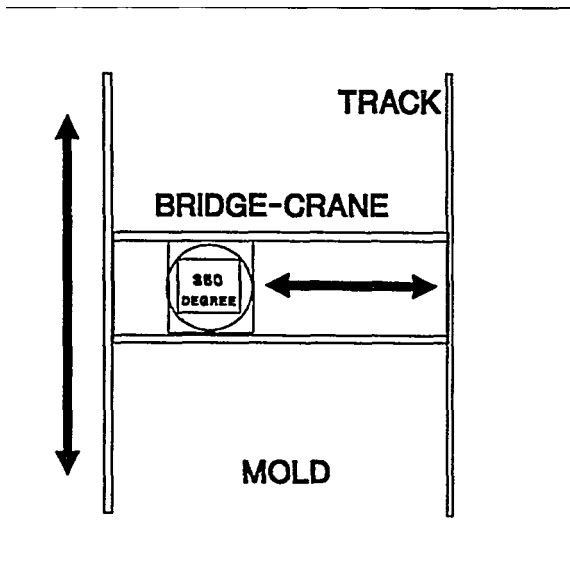

Figure 5. Bridge-Crane Impregnator

### Gantry Impregnator

In an extremely large shop or in a shop having an extremely high ceiling clearance, it may become preferable to mount a bridge upon a gantry arrangement (figure 6). Either one or two sets of gantry legs may be used, depending on the availability of a wall for mounting tracks to hold one side of the bridge carriage. A major detriment to gantry arrangements is the necessity of heavy gantry structures to support a free vertical structure, as well as the additional floor space that must be allocated to accommodate the gantry tracks. It is generally preferable to design a building that can support a free bridge span.

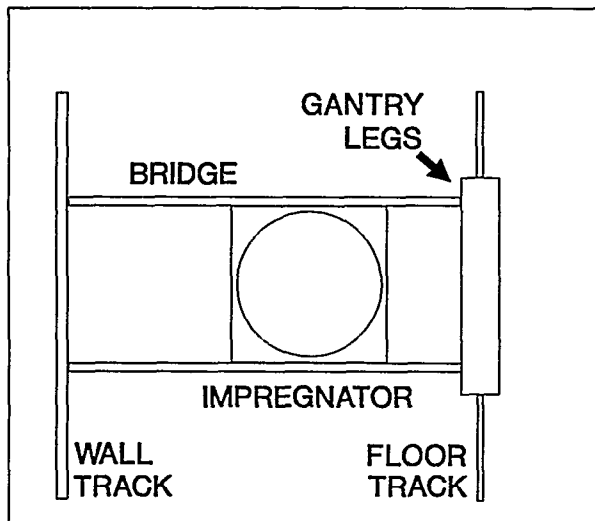

Figure 6. Gantry Impregnator

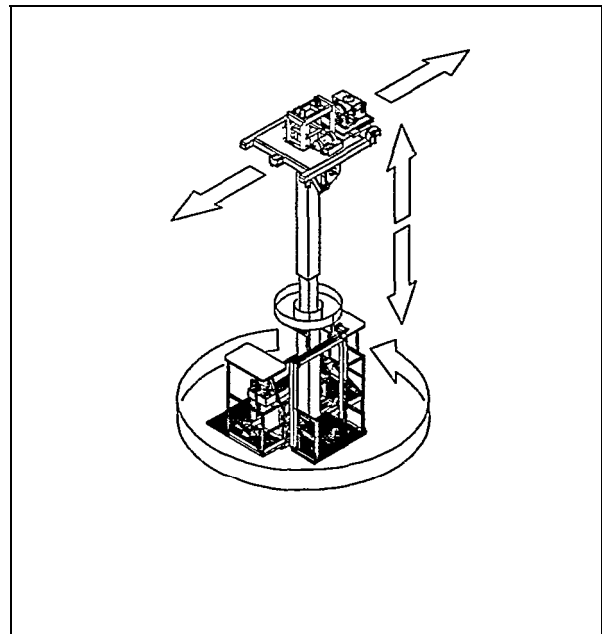

Figure 7. Telescoping impregnator

### Telescoping Impregnator

In the lamination of composite MCM vessels, the addition of another axis in the form of a telescoping vertical movement becomes highly desirable due to the increased vertical distance from keel to gunnel. The limitation of most impregnator systems is the amount of vertical material drop that can be tolerated. Excessively heavy lamination suspended from the impregnator will result in slippage through traction rollers and nip rollers, and a loss of laminate and production time. By moving the entire impregnator assembly vertically, through the use of a driven telescope, it becomes possible to position the machine directly next to, or even against, the mold itself for lamination and/or roll-out purposes (see further description of roll-out technology). The Telescoping Impregnator design allows more accurate positioning of material overlaps and also allows working in tight areas such as molded keels and bow contours with tight radii. When laminate must be trimmed during molding of a segment not ending at the gunnel, excessive waste can be avoided by operating the machine in close proximity to the mold.

### Mechanized Roll-Out Systems

An additional refinement has recently been made to the telescoping impregnator system allowing mechanical roll-out for air-void removal. Air-void removal has remained a major factor in labor cost, since ultimately, two layers of material must be layered together with subsequent air entrapment between layers. Impregnation equipment (patent applied for) has recently been shipped to the United Kingdom from the United States which permits mechanized roll-out of air in large flat expanses of laminate. As marine structures increase in size and weight, the addition of mechanized roll-out systems become a near necessity.

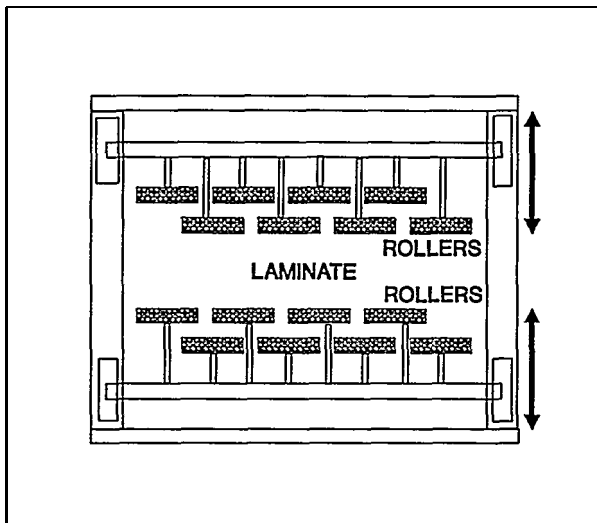

Figure 8. Mechanized Rollout (patent pending)

As seen in figure 8, mechanized roll-out takes place beneath the telescoping impregnator with two sets of reciprocating finned metal rollers similar to those used by hand laminators. The reciprocating movement against the laminate is more rapid and more effective than manual roll-out techniques.

Mechanized roll-out machinery has also been constructed for stand-alone units to be operated independently of impregnator bridge-crane machinery. This allows simultaneous operation of bridge-crane or telescoping impregnators with mechanized roll-out machinery operating in individual work areas.

#### METER/MIX TECHNOLOGY

Without properly metered and mixed chemistry for the process, composite hull and superstructure production quickly becomes a shaky proposition. An unfortunate characteristic of polyester resin is that poorly mixed and metered polyester materials often appear to the observer to be fully cured. Polyester is extremely forgiving of poor metering and mixing due to the self-propagating cross-linking that quickly penetrates from cured areas to uncured areas. The problem with this characteristic is that slightly undercured areas may not be apparent until years of osmotic blistering have revealed those areas that accept moisture more readily.

#### Slave Arm Metering

As illustrated in figure 9, the most common method of metering and mixing polyester resin with MEKP (Methyl Ethyl Ketone Peroxide) or BPO (Benzoyl Peroxide) catalyst is the interlocking slave arm pump system. By locking a resin pump with a catalyst pump, it becomes possible to reliably meter polyester and MEKP over extended periods of time. It is generally accepted that a precision-machined catalyst pump constructed of stainless steel materials will out-perform sophisticated electronic digital metering pumps, which are subject to maintenance and training problems. By simply moving the catalyst

pump along the length of the slave arm assembly, it is possible to vary the stroke length of the catalyst pump proportionately from 0.5% to 1.5%. Additional catalyst may be metered by the addition of another slave arm pump or by increasing the size of the slave arm pump. A pneumatic powerhead is usually used to power the resin pump as well as the slave arm assembly. Pneumatic drive motors are highly reliable and offer the additional advantage of being non-sparking in a flammable environment. In some instances, it may be desirable to add 2000 watt in-line fluid heaters; contained in appropriate housings, they warm the polyester resin and allow it to be moved more readily through the long hose lengths to the overhead impregnation device. Digital electronics may be utilized to monitor flow rate of resin, catalyst, and fiberglass, thereby monitoring ratios; however, use of computer servo-loops, etc., is usually to be avoided as an unnecessary addition to maintenance problems.

#### MATERIALS

##### Polyester Resin

Polyester resin accounts for a vast majority of composite marine structures. Low-cost orthophthalic resin systems are usually selected for recreational vehicles and less critical marine applications. However, as service becomes more severe, many naval architects are specifying isophthalic or vinyl ester systems for composite hulls and superstructures. Analysis of gel coat blistering tendencies has revealed that isophthalic systems and vinyl ester resins offer significant advantages over orthophthalic systems.

##### Epoxy

When high cruising speed or design tolerances become critical, epoxy laminations are sometimes specified. Epoxy offers greater strength per unit of weight. However, the cost is significantly higher and curing heat is

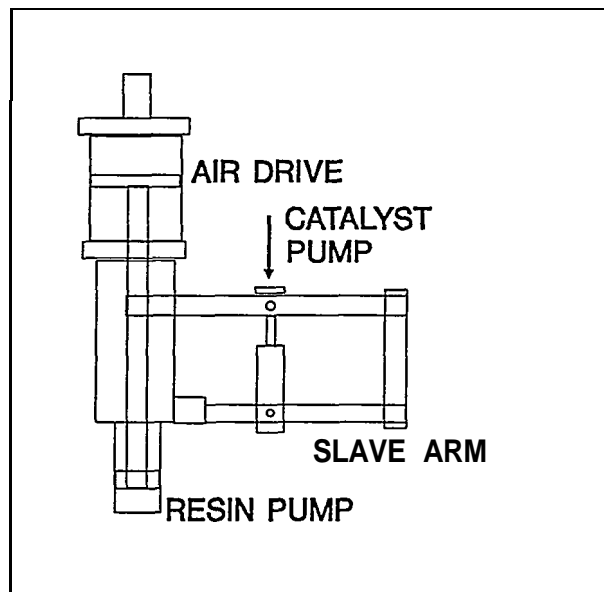

Figure 9. Slave-arm Metering

often required to achieve design specifications. Epoxies are typically higher in viscosity than polyesters and may require vacuum bags or other technology to achieve good wet out during lamination. For these reasons, epoxies are rarely seen in marine vehicles exceeding twenty feet in length.

### Phenolic Resins

Recent technology has allowed the U.S. Navy to incorporate phenolic/fiberglass composite armor in deckhouses for the LHD class of multi-purpose amphibious assault ships. Scheduled to be christened in 1991, the USS **Essex** will be outfitted with glass fiber/phenolic armor for deckhouse protection. The first marine use of phenolic/fiberglass by the U.S. Navy was for retrofitting the hangar doors of the aircraft carrier USS **America** in 1987. Phenolic resins offer advantages of superior fire resistance and low smoke generation when compared to other thermosetting resins. Although phenolics are more brittle than polyester or epoxy, the short-comings in strength may be made up by increased thickness of armor. Phenolic materials have been processed through closed-mold Resin Transfer Molding (RTM) processes and spray-up processes. Some problems exist with the toxicity of phenolics, especially when sprayed in an uncontrolled-fume environment. Phenolics are some of the oldest plastic compounds in existence and are recently showing new promise for fabrication of armor systems for military applications.

## REINFORCING FIBERS

Selection of proper reinforcing materials is a huge factor in the success or failure of mechanized production of composite hulls and superstructures. A tremendous variety of woven, knitted, and stitched fiberglass material is available on the market, with other variations of spun and combination materials also being offered as solutions to construction of composite military equipment.

### Woven Roving

Woven Roving offers a combination of low-cost, easy processability, and ready availability. Woven Roving has a fairly loose weave and easy saturation of resin through the weave structure. Material is easily draped, conforms to complex contours, and readily shifts its configuration to accommodate draping problems. For non-critical applications such as pleasure craft, fishing boats, and other non-combat vessels, simple woven roving structures are economical and offer better-than-adequate strength.

### Knitted Reinforcements

When woven roving is subjected to tensile stresses, the radii within the woven configuration are pulled straight, thereby allowing additional stress to be transferred to the resin matrix but preventing the fibers from developing their full strength. This situation can be prevented by utilizing fully straightened reinforcements stitched together in layers. This system also allows additional flexibility in designing knitted materials having proportional amounts of

reinforcement in the desired direction. Knitted materials or unidirectional materials, unfortunately, offer greater resistance to resin penetration and also naturally develop a higher fiber volume content due to the geometry of the reinforcements. These materials have been commonly processed through impregnators at reduced throughput rates.

### Combination Woven/Chop-Strand Mat

Combinations of woven roving and chopped-strand mat have been successfully processed through impregnators for many years. A layer of chopped-strand mat may be stitched or bonded to a layer of woven or knitted roving to achieve a better surface interface through layers of continuous fibers.

Two contacting layers of woven roving may sometimes not achieve a high percentage of contact interfaces where two weaving "peaks" meet between layers. A layer of chopped-strand mat between woven layers greatly improves this interface, but also contributes to thickness and weight of the laminate.

The most successful combinations of materials processed by impregnators to date have been those where the woven material is stitched to the mat with a z-axis fiber. Binders seem to create an additional barrier to resin penetration and allow the chopped-strand mat to fall from the face of the woven roving if suspended from the machine for more than five minutes.

### Kevlar and Carbon Fibers

Advanced composite high-modulus reinforcements are not commonly found in the marine industry due to their cost and the minimal impact of weight reduction on a

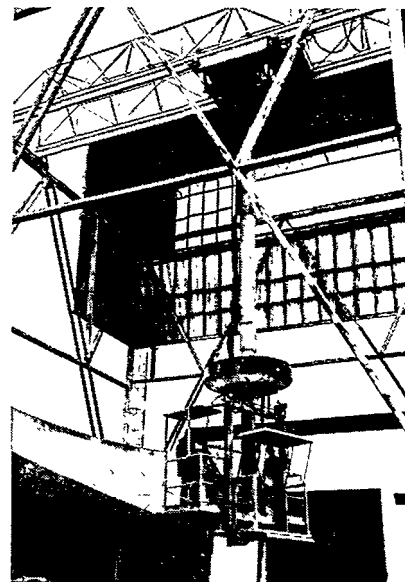

Figure 10. Telescoping Bridge-Crane Impregnator

marine structure design. For high-speed patrol boats and other high-speed vessels, carbon fibers or Kevlar are sometimes used for their high performance characteristics. Carbon fibers and Kevlar® are typically processed as a prepreg to be vacuum bagged and cured by autoclave; however, some success has been achieved with processing through RTM or closed-mold processing methods (where the fibers are closed in a mold prior to injection with meter/mix equipment). Kevlar® has been successfully processed by an impregnator for application in armor plate applications.

## **CONCLUSION**

Large-scale machinery for processing of advanced composites offers an effective means of monitoring and improving quality, and reducing labor. As larger vessels are constructed, especially for military operations, traditional hand-lamination methods no longer offer the precision required to take advantage of the physical properties offered by machine-laid composites. The ordinary quality standards of the recreational boating industry can not and should not be applied to high-displacement vessels or vessels designed for combat applications.

## **GLOSSARY OF ACRONYMS**

BPO	Benzoyl peroxide.
FRP	Fiber reinforced plastic panels.
MCM	Mine hunter counter-measure vessels.
MEKP	Methyl ethyl ketone peroxide.
MHX	Mine hunter counter measures.
MSH	Minesweeper hunters.
RTM	Resin transfer molding.

®Kevlar is a registered trademark of E.I. duPont

Additional copies of this report can be obtained from the  
National Shipbuilding Research and Documentation Center:

**<http://www.nsnet.com/docctr/>**

Documentation Center  
The University of Michigan  
Transportation Research Institute  
Marine Systems Division  
2901 Baxter Road  
Ann Arbor, MI 48109-2150

Phone: 734-763-2465  
Fax: 734-763-4862  
E-mail: [Doc.Center@umich.edu](mailto:Doc.Center@umich.edu)