

**SHIP PRODUCTION COMMITTEE  
FACILITIES AND ENVIRONMENTAL EFFECTS  
SURFACE PREPARATION AND COATINGS  
DESIGN/PRODUCTION INTEGRATION  
HUMAN RESOURCE INNOVATION  
MARINE INDUSTRY STANDARDS  
WELDING  
INDUSTRIAL ENGINEERING  
EDUCATION AND TRAINING**

September 1991  
NSRP 0340

# **THE NATIONAL SHIPBUILDING RESEARCH PROGRAM**

**1991 Ship Production Symposium  
Proceedings:  
Paper No. IIIB-1  
Composite Materials and Naval Sur-  
face Combatants: The Integrated  
Technology Deckhouse Project**

U.S. DEPARTMENT OF THE NAVY  
CARDEROCK DIVISION,  
NAVAL SURFACE WARFARE CENTER

# Report Documentation Page

*Form Approved  
OMB No. 0704-0188*

Public reporting burden for the collection of information is estimated to average 1 hour per response, including the time for reviewing instructions, searching existing data sources, gathering and maintaining the data needed, and completing and reviewing the collection of information. Send comments regarding this burden estimate or any other aspect of this collection of information, including suggestions for reducing this burden, to Washington Headquarters Services, Directorate for Information Operations and Reports, 1215 Jefferson Davis Highway, Suite 1204, Arlington VA 22202-4302. Respondents should be aware that notwithstanding any other provision of law, no person shall be subject to a penalty for failing to comply with a collection of information if it does not display a currently valid OMB control number.

1. REPORT DATE <b>SEP 1991</b>	2. REPORT TYPE <b>N/A</b>	3. DATES COVERED <b>-</b>			
4. TITLE AND SUBTITLE <b>The National Shipbuilding Research Program, 1991 Ship Production Symposium Proceedings: Paper No. IIB-1: Composite Materials and Naval Surface Combatants: The Integrated Technology Deckhouse Project</b>		5a. CONTRACT NUMBER			
		5b. GRANT NUMBER			
		5c. PROGRAM ELEMENT NUMBER			
6. AUTHOR(S)		5d. PROJECT NUMBER			
		5e. TASK NUMBER			
		5f. WORK UNIT NUMBER			
7. PERFORMING ORGANIZATION NAME(S) AND ADDRESS(ES) <b>Naval Surface Warfare Center CD Code 2230-Design Integration Tools Bldg 192, Room 128 9500 MacArthur Blvd, Bethesda, MD 20817-5700</b>		8. PERFORMING ORGANIZATION REPORT NUMBER			
9. SPONSORING/MONITORING AGENCY NAME(S) AND ADDRESS(ES)		10. SPONSOR/MONITOR'S ACRONYM(S)			
		11. SPONSOR/MONITOR'S REPORT NUMBER(S)			
12. DISTRIBUTION/AVAILABILITY STATEMENT <b>Approved for public release, distribution unlimited</b>					
13. SUPPLEMENTARY NOTES					
14. ABSTRACT					
15. SUBJECT TERMS					
16. SECURITY CLASSIFICATION OF:			17. LIMITATION OF ABSTRACT <b>SAR</b>	18. NUMBER OF PAGES <b>12</b>	19a. NAME OF RESPONSIBLE PERSON
a. REPORT <b>unclassified</b>	b. ABSTRACT <b>unclassified</b>	c. THIS PAGE <b>unclassified</b>			

## DISCLAIMER

These reports were prepared as an account of government-sponsored work. Neither the United States, nor the United States Navy, nor any person acting on behalf of the United States Navy (A) makes any warranty or representation, expressed or implied, with respect to the accuracy, completeness or usefulness of the information contained in this report/manual, or that the use of any information, apparatus, method, or process disclosed in this report may not infringe privately owned rights; or (B) assumes any liabilities with respect to the use of or for damages resulting from the use of any information, apparatus, method, or process disclosed in the report. As used in the above, "Persons acting on behalf of the United States Navy" includes any employee, contractor, or subcontractor to the contractor of the United States Navy to the extent that such employee, contractor, or subcontractor to the contractor prepares, handles, or distributes, or provides access to any information pursuant to his employment or contract or subcontract to the contractor with the United States Navy. ANY POSSIBLE IMPLIED WARRANTIES OF MERCHANTABILITY AND/OR FITNESS FOR PURPOSE ARE SPECIFICALLY DISCLAIMED.



# Composite Materials and Naval Surface Combatants: The Integrated Technology Deckhouse Project

Pat Cahill, Associate Member, Bath Iron Works

IIIB-1

## ABSTRACT

Composite materials, particularly fiberglass, have created a revolution in commercial marine design and construction over the past 20-30 years. The U.S. Navy, however, has been slow in recognizing the value of composite materials and implementing their use. The current construction of a fiberglass minesweeper will introduce composites into the auxiliary Navy, but major surface combatants have yet to take advantage of their unique material properties.

The Integrated Technology Deckhouse (ITD) Project has been steadily progressing toward the goal of constructing Naval combatant deckhouses out of an integrated system of steel and composites. The approach of the ITD Project has resolved problems and issues in phases, with each phase becoming progressively narrower in scope and greater in detail. The first phase of the project was primarily a materials and structural concepts trade-off study. Material properties were reviewed for a variety of fiberglass composites and design concepts, resulting in a trade-off matrix. The second phase included a shipyard producibility study. Issues associated with working with composites in a modular, steel construction environment were addressed. Recommendations from this study were then addressed in detail in a follow-on producibility study.

In the most recently completed study, the producibility issues associated with the design and construction of the DDG-51 Class forward Close In Weapons System (CIWS) maintenance enclosure were addressed. This paper reviews the progress to date in the ITD project, highlighting the significant issues and explaining why some of the major decisions were made. Emphasis is placed on the most recent phase of the project, which concentrated on a specific ship unit.

## INTRODUCTION

The continuing efforts of the U.S. Navy to reduce weight and increase survivability of Naval combatants has led to the serious development of composite technology for use on combatant ships. Composites, especially fiberglass, have revolutionized design and construction in the commercial marine industry. Until recently the impact has been primarily on pleasure craft and other small boats. Technological ad-

vances in materials and construction processes have led to larger composite boat designs as well as an increased interest in the use of composites by the U.S. Navy.

Although large combatant hulls will most likely continue to be constructed of steel, polymer composites may be integrated with more traditional ship building materials to form hybrid structures. Because of their high strength to weight ratios, composites are particularly attractive for weight critical areas. In the past, aluminum has been used to keep weights and centers of gravity down, but has proven to be a less than ideal material for combatant deckhouses. In the future, polymer composites may be the material of choice for deckhouse structures. The U.S. Navy's Integrated Technology Deckhouse Project is steadily progressing toward making this a reality.

## BACKGROUND

The objective of the Integrated Technology Deckhouse (ITD) Project is to enhance the survivability of U.S. Navy combatant surface ships. Composite materials have been chosen as a means to achieve this enhanced survivability because of several factors. Composites allow an integration of a number of survivability requirements, have beneficial material characteristics and may reduce maintenance requirements. One of the major advantages over steel or aluminum is in fire containment. Although composites will burn at high temperatures, the thermal conductivity is considerably less than metals. A fire occurring in a composite space will not transmit significant heat through the bulkheads to adjacent spaces. Spontaneous combustion in spaces adjacent to the fire, such as that experienced on the U.S.S. Stark, should be prevented.

Polymer composites also have excellent ballistic properties, yet are considerably lighter than equivalent steel armor plate. Reduction of topside weight, although not yet an issue on the newest Navy destroyers, is an additional advantage of composite deckhouses. Because of their high strength to weight ratios, composite materials can result in a 25%-30% reduction in structural weight. Finally, properly prepared composite materials are nearly impervious to the corrosive effects of the ocean environment, resulting in reduced maintenance.

The ITD Project has been on-going since 1987, with sponsorship by Operational Navy (OPNAV) Code 03C2,

program management by Naval Sea Systems Command (SEA) Code 5112 and technical management and coordination by SEA55Y. David Taylor Research Center in Carderock and Annapolis, Maryland has played a key role in resolving technical problems. The Navy has used a design agent as prime contractor to complete much of the design and engineering work and to subcontract work out to shipyards and composite manufacturers. Additionally, there has been active participation since the inception of the project by three major surface combatant construction shipyards. The early involvement of the shipyards has been extremely valuable in ensuring that technical concepts developed in the labs and by the design firm can actually be built in a shipyard.

The project has been established as a three phase effort. Phase A, from FY87 to 1st quarter FY89, was a concept development and material characterization stage. Phase B, dedicated to technical development and validation of design details and structural elements, is scheduled through FY91. During this phase the efforts of the project were, and continue to be, focused on the construction of a Close In Weapons System (CIWS) maintenance enclosure for DDG51 Class destroyers. Phase C, scheduled for FY92-FY94, is planned to be the full scale deckhouse unit fabrication, erection and evaluation.

The project is currently on schedule and well into Phase B. The CIWS structural design is nearly complete, and the testing of design details will occur during the summer of 1991.

#### PHASE A

Phase A consisted of a number of paper studies and small scale testing. The paper studies included identification of technology areas and definition of design criteria. Phase A culminated in an *overall Material Systems* and Structural Concepts Trade-off Study. A number of different material systems were considered for use in the ITD Project. Five major factors were used as evaluation criteria in deciding which material was best suited for the project. These factors were:

- specific strength
- fire resistance
- environmental suitability
- fragmentation protection
- acquisition cost and availability

Using these evaluation criteria a fiberglass composite made from a woven roving E-glass solid laminate vinylester resin system was chosen as the primary material. The additional strength characteristics of a 70% glass (70% glass to resin weight ratio) system made it the primary choice for exterior and structural bulkheads, while a 50% system was recommended for non-structural and joiner bulkheads.

The second part of the study evaluated a number of different structural concepts for composite deckhouse construction. Molded construction and modular construction using a framework and panels were both considered, with modular construction chosen for the project. Modular con-

struction eliminates the need for molds, does not require extensive facility upgrades by shipyards building primarily steel combatants, incorporates construction techniques familiar to most shipyards and may reduce the risk and costs associated with repairs and rework. Composite panels are also easier to ship from the fabrication facility to the shipyard than large molded structures.

Once this decision was made a number of new issues arose, including composite versus steel framework, single bay versus multi bay panels, integral versus non-integral stiffeners and adhesive versus mechanical fastening. Candidates were evaluated using the following criteria:

- structural weight
- ballistic performance
- fire containment
- electromagnetic properties
- producibility, repairability and maintainability

At this stage of the program a matrix of concepts and their advantages and disadvantages was developed rather than selecting a specific concept, as the optimum structural concept will be dependent on the actual deckhouse configuration.

#### PHASE B

Phase B of the ITD Project concentrated initially on solving the air blast and fire issues, as well as continued shipyard support. A simulated nuclear air blast test was performed on a small (2.44m (8') by 2.44m (8') by 4.88m (16')) composite module. In addition, a series of fire tests, including a large scale "Stark" fire simulation, were conducted on a similar sized module. The results of these tests supported the choice of materials.

An in depth shipyard producibility study was also conducted during this phase. The study identified and resolved producibility issues associated with the design and construction of a generic composite deckhouse structure. Significant contributions were made to the ITD Project in the areas of fabrication, safety and non-destructive testing and evaluation techniques. Methods of construction were reviewed and several alternatives identified for most production tasks.

The study made a number of recommendations pertaining to panel fabrication and storage. Composite panels will be manufactured by a vendor contracted through the shipyard, as the yards currently involved in major naval combatant construction have limited capability for large scale fiberglass panel fabrication. The shipyard or design agent will provide the manufacturer with the necessary design information to fabricate either custom or standard panels. Gel-coat will be applied by the panel manufacturer to prevent environmental damage to the panels during construction. Panels must be carefully handled and stored, preferably in a vertical racking system.

The design of the deckhouse panels should minimize the requirement for cutting and trimming of the panels by the



fabricated using the 70% E-glass/vinylesteres in system. The initial design called for one half inch solid laminate panels, thickening to three-quarters inch at the edges to provide a stronger faying surface. The design had foam or balsa cored hat stiffeners integrated into the panels during layup, a steel framework consisting of angles at the joints, and a steel flat bar at the deck and bulkhead connections. The angles were connected to the panels using steel bolts and the edges sealed with the same vinylester resin used in the panel fabrication.

It was anticipated that the assembled unit will be temporarily erected on the ship, and the deck and bulkhead edge locations scribed onto the adjoining units. The enclosure will then be removed and the flatbar (with pre-drilled bolt holes) welded in place and straightened as necessary. The fully assembled enclosure is then lifted back onto the ship and bolted in place, applying a resin sealer to the joints. This preliminary construction method was later modified during the shipyard study.

A small number of outfitting details, based primarily on techniques developed during design of the MHC-51 Class Coastal Minehunters, were also provided with the preliminary design. These included methods for installing pipe and vent hangers, electrical cableways and foundations.

## **CONSTRUCTION PHILOSOPHY**

Previous studies recommended the continued use of modern modular construction and zone outfitting methods currently in use in many shipyards. The CIWS study concurred with the recommendations and identified construction approaches that will result in as little deviation as possible from present shipbuilding practices.

## **STORAGE AND HANDLING**

One of the initial steps in the construction process is the receipt and storage of construction materials. The expense and long lead times associated with composite panels requires a more careful process than that used with steel plate. To prevent environmental damage prior to erection on the ship the panels should be stored inside. A vertical racking system is the preferred method of storage, particularly for custom panels, as the panels will only have to be moved once during each construction phase. Each panel will also be readily accessible when needed.

Several methods of handling the composite panels were recommended by the various shipyard studies. The use of vacuum cups appears to be the best method as no modifications to the panels are required. Other methods include the use of slings, which is labor intensive; holes drilled in the panels, which will require later rework; and laminated fiberglass padeyes. An advantage of laminated padeyes is that, if properly designed and located, they may be left in place and used for unit lifting and erection of temporary scaffolding.

## **PANEL DESIGN**

The next step to consider was the design of the panels

themselves. Earlier studies had considered both custom made and standard panels, with custom panels as the final recommendation. For a DDG-51 Class deckhouse this is the only logical choice due to its unusual configuration and varied geometry, as shown in Figure 3.

The use of standardization during custom panel design and fabrication should, however, result in lower shipbuilding costs. Maintaining a degree of consistency between panels allows the shipbuilder to fabricate connection and mounting parts on a large scale, rather than designing and fabricating completely unique pieces for each panel. It also allows the tradesmen to develop a familiarity with the product, which eventually results in reduced production manhours. Stiffener spacings and dimensions, panel thicknesses and faying surface widths are some of the items that, if held to a strict standard, will reduce overall costs.

An additional consideration is the amount of pre-outfitting to be accomplished by the panel vendor. By working with the shipyards on a jointly developed design the panel manufacturers should be able to fabricate panels that incorporate a number of attachment points for outfit items, resulting in a shorter production cycle in the shipyard and fewer opportunities to damage the panels during the production process. The disadvantage to this is the possibility of improperly located attachment points resulting in rework and delays. Strict quality assurance procedures and accurate, fixed designs will prevent this problem.

## **FRAME DESIGN**

The next major design consideration was the type of framing system to use. It was decided relatively early in the ITD project to use a steel or composite frame system to hold the panels together. Several factors must be considered in the design of a framing system. It must be adaptable to several types of composite joints, all of which will be addressed by the CIWS maintenance enclosure. These include:

- GRP deck to GRP bulkhead
- GRP deck to steel bulkhead
- GRP bulkhead to steel bulkhead
- GRP bulkhead to steel deck

Panels and their connections must be designed for nuclear air blast loading, meeting strict requirements for panel deflection, sheer and bending moments. The framing system should minimize weight, but not at the expense of producibility. Finally, the unique configuration of the DDG-51 deckhouse units will require the use of non-standard shapes.

Two types of framing systems were considered as candidates for the CIWS enclosure. Each has its merits and its disadvantages. The first type, with framing members located only at the panel edges, is shown in Figure 4.

The panels are bolted to the frame members and act together to provide the structural strength and stiffness of the unit. This type of framing system will allow the use of composite framing members and offers the minimum structural weight. Construction using this framing method will



ing, adhesives and welding, as well as combinations of the aforementioned. The early ITD studies considered steel plates embedded in the edges of the panels and then welded to the adjacent deck or bulkhead. This was ruled out because it was assumed that the high heat from welding would cause significant damage to the composite panels.

The suggested method was to weld the steel coaming to the adjacent structure and then bolt the composite panels to the coaming. The problem with this method is that difficulties in obtaining alignment within tolerances are anticipated when erecting the assembled composite unit onto the ship. An alternative method that will prevent alignment problems by allowing welding near the panels needed to be developed.

The CIWS study proposed that the transition pieces be temporarily bolted to the panels until the unit is erected and supported by temporary jacking stools. Once proper alignment is obtained the transition pieces will be welded to the adjacent steel plate and the permanent bolts installed and torqued down. This method still left the heat damage issue open.

In order to verify the practicality of the proposed construction method a welding heat experiment was conducted. Steel flatbars of varying thickness and width were welded into a tee shape with temperature probes attached to the vertical member of the tee as shown in Figure 6.

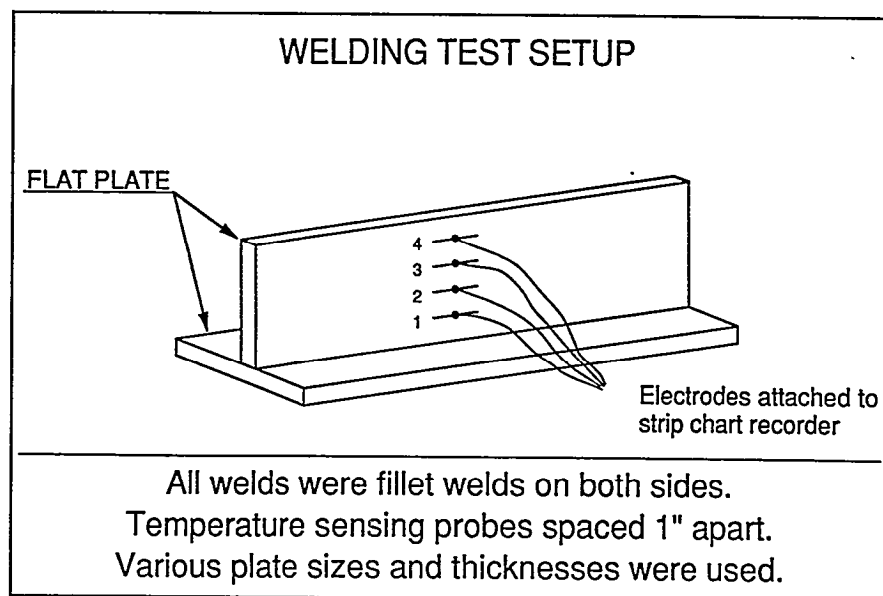

Figure 6

Two different types of welders were used; a pulse gas metal arc welder and a flux core welder, which is the hotter of the two. Single and double passes were conducted, as well as several with a preheat to simulate summer conditions. The temperature of the plate was measured at one inch increments from the weld and recorded on a strip chart recorder for the duration of the weld.

The critical temperatures for the E-glass/vinylester resin panels are shown in Table I.

Table II shows the test results. The results of this test demonstrate that depending on the type of plate used it may be possible to weld as close as one inch to the composite panels without significant damage, validating the proposed construction method. Several types of connections using this method were designed, with the preferred option shown in Figure 7.

## OUTFIT DESIGN

Outfitting methods to be employed are another major challenge of the project. Outfitting includes the installation of all piping and mechanical equipment, combat systems and equipment, electrical equipment and cableways, ventilation ductwork and hull outfit items such as doors, ladders, gratings and habitability components. A steel or aluminum deckhouse is typically outfitted by welding foundations or hangers onto the structure and attaching the system or outfit items to them. Obviously this cannot be done with a composite structure. In most cases the existing hanger designs can be used, but the method of attaching them to structure will be modified. A number of possible methods were developed as part of the CIWS study, including attachment with adhesives, laminated attachment points, through bolts on stiffeners and bolting through the panels. Tap screws and rivenuts can also be used, provided shock requirements are met. Figures S-11 show examples of the different types of methods that were conceived during the CIWS study.

## REWORK AND SHIPYARD REPAIRS

Rework during construction on a steel structure often requires cutting or burning off the incorrect component, grinding down the steel plate surface and welding a new component in place. Rework with composites may, however, result in a labor intensive sanding, patching and re-laminating process. It is anticipated that common fiberglass boat building technology will be used to accomplish any required repairs.

Nomenclature	Temperature	Effect
Glass Transition Temperature	100 deg C 212 deg F	Surface changes and resin softening. Depth of laminate exposed to 100 deg is degraded.
Thermal Degradation	200 deg C 392 deg F	Gas emission, volatiles separate without burning- Phase change starts on surface.
Thermal Decomposition	300 deg C 572 deg F	Laminate starts to char and burn. More gases released. Permanent damage results.

Table I

WELDING TEST RESULTS						
HORIZ PLATE	VERT PLATE	PEAK TEMPERATURE				
		NEAR(FAR)	NEAR(FAR)	NEAR(FAR)	NEAR(FAR)	
3/16"X8"	3/16"X4"	360(300)	210(190)	180(160)	N/A	*#
3/16"X8"	3/16"X8"	370(365)	210(210)	165(160)	140(130)	* #
1/2" X8"	3/16"X4"	280(265)	160 (160)	140(140)	N/A	*#
1/2"X8"	1/2"X4"	510(460)	360 (330)	320 (300)	N/A	*+
1/2"X8"	1/2"X8"	480(460)	330 (310)	260 (240)	210(200)	§+
3/16"X8"	3/16"X8"	400(370)	280(260)	200(200)	185(170)	*#.
1/2"X8"	1/2"X8"	500 (510)	360 (360)	280(280)	240(240)	§+.

. Pulse gas metal arc welder # 1/8" fillet weld  
 § Flux Core welder + 3/8" fillet weld  
 . Preheat to 200 °F, cooled to 180°F prior to welding

Table II

Since fiberglass resin layup normally requires an environment with controlled temperatures and humidity, rework will present some difficulties on the shipways, particularly during winter months. For the CIWS enclosure a temporary cover and space heaters will be adequate, but this problem must be addressed prior to construction of an entire deckhouse. The best solution is to avoid rework altogether, making it especially important to ensure that design and construction practices minimize the possibility of errors.

**PAINTING AND CORROSION CONTROL**

The use of an integrated system of steel and composites presents a unique challenge for corrosion control. Although the composites are not themselves susceptible to

corrosion they are not impervious to environmental damage. If not properly coated the long term effects of ultraviolet radiation will cause material degradation. Long term exposure to the ocean environment will also result in water and mineral absorption problems. A gel coat applied by the panel manufacturer will discourage these problems, but touch-up will be required by the shipyard prior to final painting.

The design used to integrate the steel and composites may also create crevice corrosion problems on the steel members. Steel erection units are normally grit blasted and primed prior to accomplishing most pre-outfitting. A steel/composite unit can not be put through the normal blasting process, so the steel framing members must be prepared separately prior to bolting to the panels. Weldable primer will

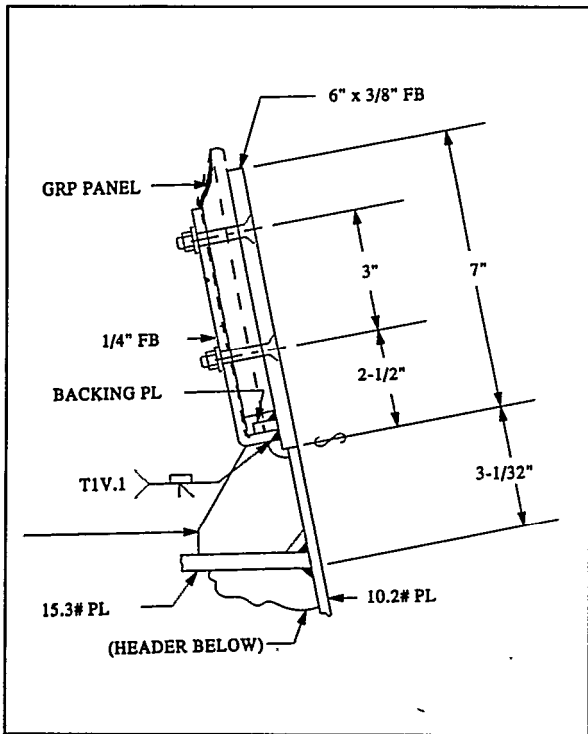

Figure 7

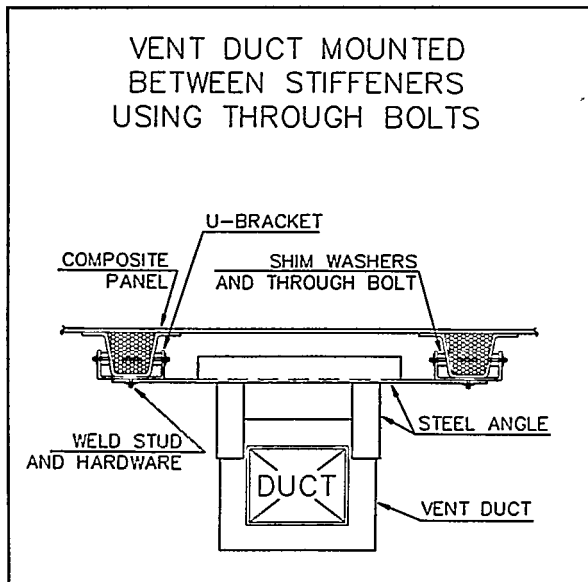

Figure 8

have to be used on most parts to allow for welding. Flexible caulking is required at the composite/steel interface to create an air and watertight seal. The seal must remain intact during normal expansion and contraction of the steel plate from ships motion and environmental heating and cooling.

Actually putting a unit to sea and exposing it to the rigors of the ocean environment will test the effectiveness of these protective measures. New inspection and underway painting procedures must be developed to counter corrosion problems that may occur.

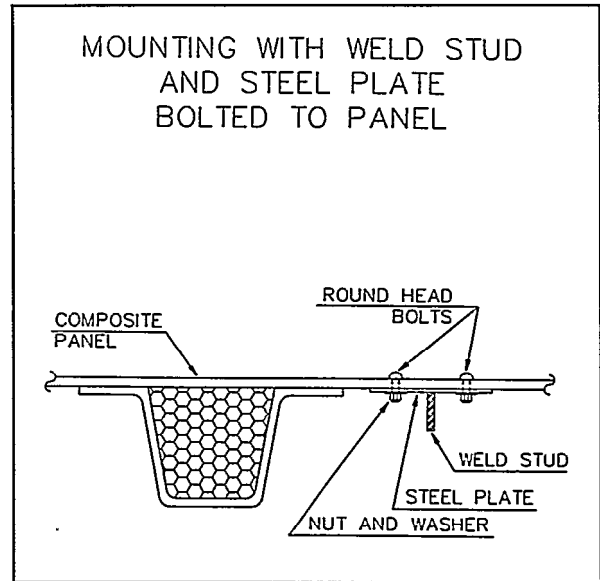

Figure 9

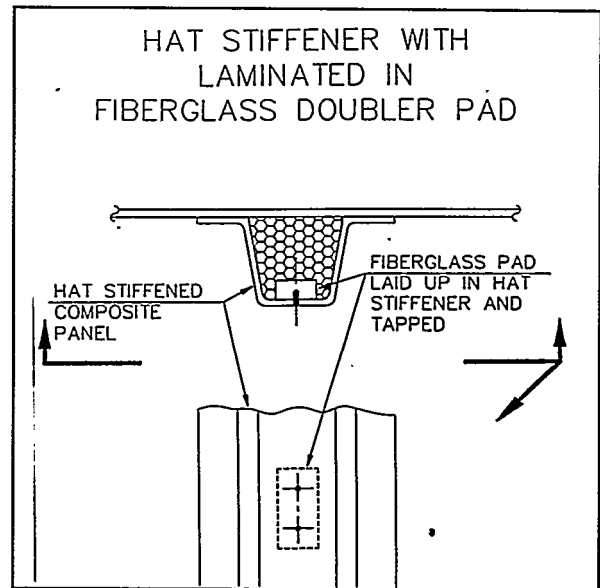

Figure 10

## MAINTENANCE REQUIREMENTS

Maintenance of a composite/steel structure by ship's force will be far different than that required for an all steel or aluminum vessel. Maintenance must become more inspection oriented and conditional, fixing defects or problems as they are found rather than performing regular preventive maintenance. Training will be required to instruct crew members on how to detect damaged gel coat, blisters, delamination and corrosion at the steel/composite interface. Period checks on bolts and seals will be required and care must be taken when performing hot work in the vicinity of composites.

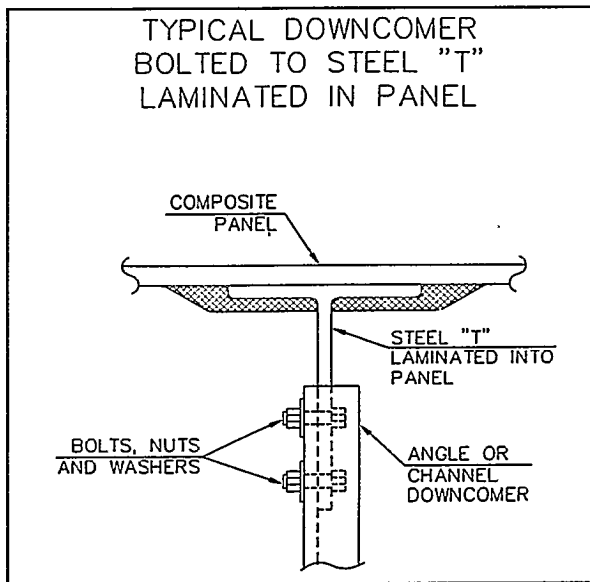

Figure 11

## CONCLUSIONS

The use of composites on large naval combatants has the potential to be a cost effective means of increasing survivability and decreasing weight. The remaining milestones prior to erection of a CIWS maintenance enclosure aboard a DDG-51 class ship will continue to present challenges to those working on the project. The successful erection and subsequent trials of the unit may potentially open the door for a larger scale introduction of this technology into naval shipbuilding.

## ACKNOWLEDGEMENTS

The author would like to thank Mr. Alan Kurzweil of Naval Sea Systems Command and Mr. Bill Gregory of CASDE Corp., two of the key players in the ITD Project, for their assistance in the preparation of this paper. Thanks also to Mr. Tim Tetu of BIW for the DDG 51 isometrics.

Additional copies of this report can be obtained from the  
National Shipbuilding Research and Documentation Center:

**<http://www.nsnet.com/docctr/>**

Documentation Center  
The University of Michigan  
Transportation Research Institute  
Marine Systems Division  
2901 Baxter Road  
Ann Arbor, MI 48109-2150

Phone: 734-763-2465  
Fax: 734-936-1081  
E-mail: [Doc.Center@umich.edu](mailto:Doc.Center@umich.edu)