

NAWCWD TP 8598

NAV  AIR

**Insensitive Munitions Technology Transition
Program Composite Case Captive Carry
Qualification (C⁴Q) Final Report**

by

Brandy Corley Flotten

Research and Engineering Sciences Department

JULY 2005

**NAVAL AIR WARFARE CENTER WEAPONS DIVISION
CHINA LAKE, CA 93555-6100**



Approved for public release; distribution is
unlimited.

Naval Air Warfare Center Weapons Division

FOREWORD

The Composite Case Captive Carry Qualification (C⁴Q) Program entails the design, the fabrication, and the ground and flight testing of a captive air training missile (CATM) with a composite primary structure. This configuration, which is commonly referred to as the composite "blue tube," maintains the form, fit, and function of the CATM-9M with the MDU-27A/A hardware and is designed to withstand the induced load and vibration environments of the F/A-18C/D. This paper provides a description of the design, analysis, test, and evaluation conducted thus far for this effort. Included is a discussion of the tailored material property characterization, design loads determination, manufacturing, ground testing, flight clearance package and documentation, flight testing, and lessons learned.

This document was reviewed for technical accuracy by Peter Hudson and James McManigal.

Approved by
J. M. ROBBINS, *Deputy*
Weapons and Energetics Department
21 July 2005

Under authority of
W. M. SKINNER
RDML, U.S. Navy
Commander

Released for publication by
K. HIGGINS
Director for Research and Engineering

NAWCWD Technical Publication 8598

Published by Technical Information Division
Collation Cover, 174 leaves
First printing 46 copies

REPORT DOCUMENTATION PAGE**Form Approved
OMB No. 0704-0188**

Public reporting burden for this collection of information is estimated to average 1 hour per response, including the time for reviewing instructions, searching existing data sources, gathering and maintaining the data needed, and completing and reviewing the collection of information. Send comments regarding the burden estimate or any other aspect of this collection of information, including suggestions for reducing this burden, to Washington Headquarters Services, Directorate for Information Operations and Reports, 1215 Jefferson Davis Highway, Suite 1204, Arlington, VA 22202-4302, and to the Office of Management and Budget, Paperwork Reduction Project (704-0188), Washington, DC 20503.

1. AGENCY USE ONLY (Leave blank)		2. REPORT DATE July 2005	3. REPORT TYPE AND DATES COVERED Summary	
4. TITLE AND SUBTITLE Insensitive Munitions Technology Transition Program Composite Case Captive Carry Qualification (C ⁴ Q) Final Report (U)			5. FUNDING NUMBERS	
6. AUTHOR(S) Brandy Corley Flotten				
7. PERFORMING ORGANIZATION NAME(S) AND ADDRESS(ES) Naval Air Warfare Center Weapons Division 1 Administration Circle China Lake, CA 93555-6100			8. PERFORMING ORGANIZATION REPORT NUMBER NAWCWD TP 8598	
8. SPONSORING/MONITORING AGENCY NAME(S) AND ADDRESS(ES) Vicki Brady Insensitive Munitions Technology Transition Program Code 474000D, Mail Stop 5301 China Lake, CA 93555-6100			10. SPONSORING/MONITORING AGENCY REPORT NUMBER	
11. SUPPLEMENTARY NOTES				
12a. DISTRIBUTION/AVAILABILITY STATEMENT Approved for public release; distribution is unlimited.			12b. DISTRIBUTION CODE	
13. ABSTRACT (Maximum 200 words) (U) The Composite Case Captive Carry Qualification (C ⁴ Q) Program was conceived to reduce the risk of employing composite materials on air-launched missiles by demonstrating that the resultant case technology is robust enough to withstand a tactical aircraft flight. This effort entails the design, the fabrication, and the ground and flight testing of a captive air training missile (CATM) with a composite primary structure. This configuration, which is commonly referred to as the composite "blue tube," maintains the form, fit, and function of the CATM-9M with the MDU-27A/A hardware and is designed to withstand the induced load and vibration environments of the F/A-18C/D. (U) This program substantiates that a high degree of confidence can be placed in the composite material's intrinsic properties and provides confidence that a timely flight clearance can be obtained for a weapon that incorporates composite technology. During this work, the investigators overcame numerous technical challenges that have traditionally prevented the application of filament-wound composite cases to tactical missile design. These issues include, but are not limited to, impact damage and moisture intrusion. The goal is to highlight the issues that must be addressed in a composite case certification program. (U) This document provides a description of the design, analysis, test, and evaluation conducted thus far for this effort. Included is a discussion of the tailored material property characterization, design loads determination, manufacturing, ground testing, flight clearance package and documentation, flight testing, and lessons learned.				
14. SUBJECT TERMS Insensitive Munitions Technology Transition Program (IMTTP), Composite Case Captive Carry Qualification (C ⁴ Q), Captive Air Training Missile (CATM), Blue Tube, Effective Flight Hours, Non-destructive Inspection (NDI)			15. NUMBER OF PAGES 346	
			16. PRICE CODE	
17. SECURITY CLASSIFICATION OF REPORT UNCLASSIFIED	18. SECURITY CLASSIFICATION OF THIS PAGE UNCLASSIFIED	19. SECURITY CLASSIFICATION OF ABSTRACT UNCLASSIFIED	20. LIMITATION OF ABSTRACT SAR	

UNCLASSIFIED

SECURITY CLASSIFICATION OF THIS PAGE (When Data Entered)

CONTENTS

Background and Introduction	5
Scope	5
C ⁴ Q Program Objective	6
Design	6
Material Property Characterization	7
Design Loads Determination	8
Manufacturing	8
Detailed Design	8
Ground Testing.....	9
Bending Test at Room Temperature Under Dry Conditions Without Impact Damage.....	9
Bending Test After Tube Exposed to Impact Damage and Hot/Wet Conditions	9
Forward Hanger Test.....	9
Middle Hanger Test.....	9
Modified Middle Hanger Test.....	10
Aft Hanger Test	10
Wing Attachment Test.....	10
Fatigue Test.....	10
Stiffness (Modal) Test	10
Mass Properties.....	11
Vibration Test	11
Bending Test After Vibration.....	11
Bending Test With Impact Damage.....	11
Thermal Shock and Temperature, Altitude, and Humidity Tests	11
Pre-flight Proof Test	12
Bending Test Under Hot/Wet Conditions With Kevlar Overwrap Removed.....	12
Summary	12
Flight Clearance Package and Documentation	14
Flight Testing	14
Summary of Lessons Learned	15
References	17
Nomenclature	17

Appendixes:

A.	Composite Case Captive Carry Qualification (C ⁴ Q) Blue Tube Bending Test Plan.....	A-1
B.	Composite Case Captive Carry Qualification (C ⁴ Q) Blue Tube Test Report for Bending at Room Temperature Under Dry Conditions Without Impact Damage	B-1
C.	Composite Case Captive Carry Qualification (C ⁴ Q) Blue Tube Test Plan for Bending Test After Tube Exposed to Impact Damage and Hot/Wet Conditions.....	C-1
D.	Composite Case Captive Carry Qualification (C ⁴ Q) Blue Tube Test Report for Bending Test After Tube Exposed to Impact Damage and Hot/Wet Conditions.....	D-1
E.	Composite Case Captive Carry Qualification (C ⁴ Q) Blue Tube Forward Hanger Test Plan.....	E-1
F.	Composite Case Captive Carry Qualification (C ⁴ Q) Blue Tube Forward Hanger Test Report.....	F-1
G.	Composite Case Captive Carry Qualification (C ⁴ Q) Blue Tube Middle Hanger Test Plan.....	G-1
H.	Composite Case Captive Carry Qualification (C ⁴ Q) Blue Tube Middle Hanger Test Report.....	H-1
I.	Composite Case Captive Carry Qualification (C ⁴ Q) Blue Tube Modified Middle Hanger Test Plan	I-1
J.	Composite Case Captive Carry Qualification (C ⁴ Q) Blue Tube Modified Middle Hanger Test Report	J-1
K.	Composite Case Captive Carry Qualification (C ⁴ Q) Blue Tube Aft Hanger Test Plan.....	K-1
L.	Composite Case Captive Carry Qualification (C ⁴ Q) Blue Tube Aft Hanger Test Report	L-1
M.	Composite Case Captive Carry Qualification (C ⁴ Q) Blue Tube Wing Attachment Test Plan	M-1
N.	Composite Case Captive Carry Qualification (C ⁴ Q) Blue Tube Wing Attachment Test Report	N-1
O.	Composite Case Captive Carry Qualification (C ⁴ Q) Blue Tube Fatigue Test Plan	O-1
P.	Composite Case Captive Carry Qualification (C ⁴ Q) Blue Tube Fatigue Test Report	P-1
Q.	Composite Case Captive Carry Qualification (C ⁴ Q) Blue Tube Vibration Test Plan.....	Q-1
R.	Composite Case Captive Carry Qualification (C ⁴ Q) Blue Tube Vibration Test Report.....	R-1
S.	Composite Case Captive Carry Qualification (C ⁴ Q) Blue Tube Bending After Vibration Test Report	S-1
T.	Composite Case Captive Carry Qualification (C ⁴ Q) Blue Tube Bending After Impact Damage Test Report.....	T-1
U.	Composite Case Captive Carry Qualification (C ⁴ Q) Blue Tube Thermal Shock and Temperature, Altitude, and Humidity Cycling Test Report.....	U-1
V.	Composite Case Captive Carry Qualification (C ⁴ Q) Blue Tube Pre-flight Proof Test Plan.....	V-1
W.	Composite Case Captive Carry Qualification (C ⁴ Q) Blue Tube Pre-flight Proof Test Report.....	W-1
X.	Composite Case Captive Carry Qualification (C ⁴ Q) Blue Tube Test Report and Plan for Bending Test Under Hot/Wet Conditions and With Overwrap Removed.....	X-1
Y.	Composite Case Captive Carry Qualification (C ⁴ Q) Blue Tube Serial Number 015 Surface Investigation Report	Y-1

Tables:

1.	Mass Properties	11
2.	Summary of Ground Test Results.....	13
3.	Flight Log Summary	15

ACKNOWLEDGMENTS

The execution of the Composite Case Captive Carry Qualification (C⁴Q) project was the result of a collaborative effort on the part of many groups, such as Structures and Design, Materials Engineering, Life Cycle Environmental Engineering, Rapid Prototype Engineering, and the Composites Fabrication Laboratory. The Naval Air Systems Command (NAVAIR) NDE Branch provided the non-destructive evaluation and inspection guidance, and local China Lake squadron non-destructive inspection (NDI) personnel performed the follow-on inspections. Other government agencies, military personnel, and industry partners having interest in composite rocket motor cases as next-generation missile systems have also participated. This effort would not have been possible without the cooperation and assistance of all those involved. Special recognition goes to the C⁴Q team: Ted Hicks, Chuck Daugherty, Carl Kumano, Brian Haugen, George Graham, Bob Andre, Frank Goerlich, Peter Vezey, John Lundeen, Nolan Paulsen, Clay Schonhoff, Eric Matthews, Buck Guest, John Gamel, Ricardo Saenz, Gary Simpson, Peter Hudson, Craig Porter, Sharon Berry, and Antonella Thompson. The author would also like to express her thanks to Allen Gehris, Insensitive Munitions Technology Transition Program (IMTTP) NAVAIR Sponsor, and Vicki Brady, IMTTP Technical Coordinator, for their support of this initiative.

(This page intentionally left blank.)

BACKGROUND AND INTRODUCTION

Since the late 1960s, a longstanding need has existed to improve the safety of tactical missile systems. One such effort is embodied in the Insensitive Munitions (IM) Program, whose goals are to develop new systems or to retrofit current ones with technologies that will mitigate weapons' reactions to hazard stimuli resulting from shipboard fire, flying debris, or battle situations. In fact, the U.S. Navy has devoted considerable resources to improve the safety of weapons systems in shipboard applications. Significant progress in meeting these IM requirements, as well as offering enhanced kinematics performance, has been made in composite rocket motors. As with all composite structures, the mechanical properties can be tailored to meet specific stiffness and pressure requirements, an aspect that affords the ability to accommodate tactical flight loads. Other benefits include the ability to utilize more or higher-performance propellants without significantly shifting the missile's center of gravity. In addition, substantial energy has also been dedicated to develop propellants that are less sensitive and that react safely to shipboard hazards. In conjunction, these efforts provide an area of opportunity to achieve a synergistic combination of high performance and IM compliance in rocket motors.

The effort to utilize IM technology for future service is designated the Insensitive Munitions Technology Transition Program (IMTTP). IMTTP's goal is to demonstrate the readiness of various key technologies, like the composite motor, for introduction into the next-generation weapon design cycle. The uncertainty regarding the composite rocket motor's ruggedness and reliability for Fleet use, as well as for captive carriage, has, in the past, precluded that technology from being applied to tactical motors.

IMTTP funded the Composite Case Captive Carry Qualification (C⁴Q) Program, which began in fiscal year 1997 and concluded in fiscal year 2004. The program's purpose is to demonstrate the robustness of a composite rocket motor and its suitability for use in a tactical captive carriage flight environment. The total funding was approximately \$1.9M over the 7 years. In order to reduce the overall program cost, the investigators focused on several factors, such as careful material selection and streamlined manufacturing processes, and utilized AIM-9M hardware and existing loads and aerodynamic data.

The C⁴Q Program entails the design, the fabrication, and the ground and flight testing of a captive air training missile (CATM) with a composite primary structure. This configuration, which is commonly referred to as the composite "blue tube," maintains the form, fit, and function of the CATM-9M with the MDU-27A/A hardware and is designed to withstand the induced load and vibration environments of the F/A-18C/D. This document provides a description of the design, analysis, test, and evaluation conducted thus far for this effort. Included is a discussion of the tailored material property characterization, design loads determination, manufacturing, ground testing, flight clearance package and documentation, flight testing, and lessons learned.

SCOPE

Because the C⁴Q effort is neither a Fleet certification program for a composite rocket motor nor an Engineering and Manufacturing Development (EMD) program, the focus is exclusively on a generic air-to-air missile case or blue tube design. The term *blue tube*, also called a CATM, refers to an inert rocket

motor filled with simulated propellant that exhibits the same mass properties and aerodynamic characteristics as a live missile of the same variety.

Furthermore, the C⁴Q Program does not provide the statistically based design values necessary to integrate composite structures into service nor is the resultant design suitable for direct application into an existing program. Several factors preclude doing so. For example, the structure was not built as a pressure vessel, and the production process for the aft section is complex. The primary focus was merely to design the wall thickness and composite lay-up to meet the anticipated future requirements specific to a 5-inch-diameter AIM-9M configuration.

However, the C⁴Q effort does serve as a stepping-stone for programs that may be considering adopting composite airframe technology in the future. For example, this program substantiates that a high degree of confidence can be placed in the composite material's intrinsic properties and provides confidence that a timely flight clearance can be obtained for a weapon that incorporates composite technology. During this work, the investigators overcame numerous technical challenges that have traditionally prevented the application of filament-wound composite cases to tactical missile design. These issues include, but are not limited to, impact damage and moisture intrusion. The goal is to highlight the issues that must be addressed in a composite case certification program.

C⁴Q PROGRAM OBJECTIVE

The C⁴Q Program was conceived to reduce the risk of employing composite materials on air-launched missiles by demonstrating that the resultant case technology is robust enough to withstand a tactical aircraft flight. To achieve this objective, the following three major tasks were identified.

1. Establish the structural and material data requirements for a load-bearing, filament-wound composite rocket motor case to withstand the full Sidewinder AIM-9M captive carriage flight envelope on the wing of an F/A-18C/D.
2. Develop and document the flight certification process by generating sufficient and appropriate flight clearance data for approval by the Naval Air Systems Command (NAVAIR), thereby setting a precedent for future flight clearances.
3. Demonstrate the durability of the composite structure by manufacturing, testing, flying, and evaluating an inert composite rocket motor on the wing of an F/A-18C/D aircraft.

DESIGN

The composite blue tube was originally designed to withstand the captive carriage flight envelope of a Sidewinder AIM-9M missile suspended from the wing of an F/A-18C/D aircraft at peak environmental conditions—85% humidity at 215°F. The temperature was derived from the highest for the rocket motor skin (165°F), with a margin of 50°F. The motor section was designed to withstand a 4000-psi maximum expected operating pressure. This value, which is twice that of the AIM-9M, was specifically chosen to demonstrate the ability to accommodate higher-performance propellants. A second goal was to increase the stiffness of the airframe to a 50-Hz first body bending mode frequency as compared to that (42 Hz) of the AIM-9M. The resultant configuration had to maintain the mass property characteristics, external

interfaces, and outer mold lines, including the control surface size/positions of the AIM-9M CATM. In addition, the hardware was devised to be similar to that of the MDU-27A/A. The envisioned blue tube was physically the same as a functional rocket motor in every aspect, except for the filament-wound composite airframe and the wound-in features (lug attachments and wing ribs).

Nineteen blue tubes were manufactured according to the conceptual design to accommodate the number of assets required for qualification ground and flight testing. All blue tubes were examined for manufacturing flaws via pulse-echo ultrasound non-destructive inspection (NDI).

MATERIAL PROPERTY CHARACTERIZATION

A key element of the start-up tasks entailed collecting material data for the IM7 carbon fiber in conjunction with the EPON 9400 epoxy resin. The investigators found that an extensive material properties database exists for this fiber resin system. Information was collected from the Trident Program, contractor material characterization efforts, numerous projects at the Naval Air Warfare Center Weapons Division (NAWCWD), and information used to develop American Society for Testing Materials (ASTM) D5448 (Reference 1), D5449 (Reference 2), and D5450 (Reference 3) standards, all of which were consolidated into standard MIL-HDBK-17-1E (Reference 4) format. Close collaboration with other NAVAIR material and structural engineers resulted in a process that would allow the flight certification of this type of airframe to establish a template for the material data requirements specific to composite weapons.

The mechanical behavior of filament-wound composite structures is typically different from that of flat laminated structures because material properties such as resin void content, curing, micro-cracking, and free edge construction significantly affect the actual mechanical properties of the part—sometimes by as much as an order of magnitude. However, analysis and design of filament-wound structures require the same mechanical property data as used to generate general laminated structures. The majority of filament-wound composite structures are used in the rocket motor case community. Consequently, most of the test specimens are cylinders or bottles, shapes that more closely simulate the geometry of the structures to be designed and analyzed.

MIL-HDBK-17-1E (Reference 4) specifies the method and content of a material database for composite structures. It also provides a building block approach for deriving material properties and characterizing new materials. As such, this handbook was adopted in the C⁴Q material characterization effort. Per Section 6-12 of that document, coupon methods were tailored to accurately test a representative structure for filament-winding fabrication. Transverse tensile, transverse compressive, and in-plane shear mechanical properties were obtained by utilizing three ASTM standards (References 1, 2, and 3) developed to accurately measure the properties of filament-wound structures. These documents specify that a standard 4-inch-diameter, 4-inch-gage-length test cylinder be fabricated in the same manner as the filament-wound composite structure in question. The 4-inch-diameter cylinder is an industry adopted standard and ensures that consistent data are developed by both government and industry. The test methods and cylinder configuration used in these standards provide representative and accurate material properties for these specialized structures. Damage tolerance design levels for hot/wet compression and compression values after impact were established by utilizing 5-inch test bottles. The bottles were composed of a composite lay-up and filled with inert propellant, both identical to those of the blue tube configuration.

DESIGN LOADS DETERMINATION

The primary design loads were determined based on previous testing conditions defined for the captive carriage of a CATM-9M with MDU-27A/A hardware on board the wing tip station of the F/A-18A/B/C/D aircraft. In addition to these loads, an edge drop condition (which could result in localized damage) was generated. These loading conditions were used in the detailed design and analysis tasks. An existing National Aeronautics and Space Administration (NASA) Structural Analysis (NASTRAN) beam model of the current blue tube was modified for the composite unit.

MANUFACTURING

The IMTTP effort focused on demonstrating a repeatable and consistent manufacturing method to achieve the necessary structural integrity and safety margins to obtain flight clearance approval. As such, the wet filament-winding process was chosen for the composite blue tube program, primarily because of the wealth of experience available that pertained to the method and the materials. Design and fabrication of the winding mandrels and support fixtures (e.g., pads and wing ribs) and the manufacture of the metal components (i.e., hanger lug, lug pad, body joints, and wing ribs) were conducted at NAWCWD China Lake. The 19 composite blue tubes were also fabricated and assembled at that site.

DETAILED DESIGN

The detailed design effort required various types of intricate structural models. The first phase resulted in a composite lay-up that incorporated the material properties, loads, stiffness, and physical dimensions defined earlier by the requirements. This lay-up afforded the wrap angles that achieved the optimum through-the-wall tube thickness with the appropriate margins of safety. The product from the second phase was the design of the body joints, lug pads, wing attachments, and localized cutouts for the blue tube. The final stage entailed generating the drawing package and fabrication specification.

Body bending was the critical load factor for sizing the thickness of the cases. The Integrated Composites Analyzer (ICAN), a computer analysis tool used to calculate the acceptable constituent parameters for the composite structure, predicted unusually low compressive stress values. So, representative 5-inch-diameter composite blue tubes were fabricated and tested for transverse compressive properties per ASTM-D5449 (Reference 2). The results of this supplemental testing both confirmed and correlated well with the lower compressive strength values predicted by ICAN.

The compressive strength values were also found to be highly dependent on the void content of the structure. Through a series of iterative fabrication and testing trials, the investigators determined that a void content value no greater than 3.0% would achieve the required strength and stiffness based on a 0.175-inch-thick composite wall.

GROUND TESTING

The ground tests that follow represent the minimum effort required to obtain local flight clearance for demonstration purposes. The confidence and assurance of the material composite response and structural integrity were further demonstrated by the successful ground tests needed to proceed with flight testing. As such, the requirements for a Fleet certification of a composite rocket motor have not been fully satisfied.

BENDING TEST AT ROOM TEMPERATURE UNDER DRY CONDITIONS WITHOUT IMPACT DAMAGE

The most severe load scenario for the C⁴Q blue is that experienced during the Mk 84 bomb release, which imposes a 50-g peak acceleration on the wing tip station. As a consequence, a maximum bending moment of approximately 70,000 in-lb results. In the first bending test, a full-scale article was subjected to this load condition at room temperature, but without moisture conditioning or impact damage. This effort was conducted to provide a baseline for comparison and to ensure that the design was performing as predicted. Appendixes A and B provide the test plan and report, respectively.

BENDING TEST AFTER TUBE EXPOSED TO IMPACT DAMAGE AND HOT/WET CONDITIONS

The elevated temperatures and absorbed moisture that may occur during Fleet use degrade the material properties of the composite structure. Additionally, unseen impact damage can potentially decrease the strength of the structure. Both of these aspects must be addressed to provide the requisite confidence. To this end, sufficient impact was imparted to create visible damage on the two most critical locations of the blue tube. Then, the specified article was soaked at 85% humidity until equilibrium was reached, heated to the maximum design temperature (+215°F), and tested in bending while hot. Appendixes C and D are the pertinent test plan and report, respectively.

FORWARD HANGER TEST

The forward hanger represents a critical load path for the C⁴Q blue tube. As such, to verify the integrity of the design, a full-scale article was tested to failure in which the forward hanger was subjected to loading typical of that occurring at the wing tip stations. In that the load path of the forward hanger goes through the metallic structure, this effort was performed at room temperature and under dry conditions. Appendixes E and F provide the test plan and report, respectively.

MIDDLE HANGER TEST

The mid-body hanger is another area of technology demonstration. The applicable test involves a metal pad wound into the composite tube during manufacture, with a hanger bolted onto this pad. The resultant device represents a possible solution to the challenge of attaching hangers to composite rocket motors in a cost-effective and structurally efficient manner. These pads are mechanically locked into

position with composite plies and are then cured in place. As a consequence, this design approach does not require a bond between the pad and metal. Because of the difficulty of non-destructively establishing the integrity of the bond between the pad and the composite, a test was conducted to address both extremes on a middle hanger manufactured normally and one chemically released from the composite. Appendixes G and H document the test plan and report, respectively.

MODIFIED MIDDLE HANGER TEST

The performance of the original middle hanger design was marginal. However, the nature of the ultimate failure suggested an easy improvement to the configuration. As a result, the middle hanger pad was modified and re-tested, with satisfactory results. This effort also included both mechanically and chemically released hangers. Appendixes I and J provide the test plan and report, respectively.

AFT HANGER TEST

The aft hanger also represents a primary load path. As such, to verify the integrity of the design, a full-scale article was tested to failure in which the aft hanger was subjected to loading representative of that occurring at the wing tip stations. In that the load path of the aft hanger is through the metallic structure, the effort was conducted at room temperature and under dry conditions. Appendixes K and L provide the applicable test plan and report, respectively.

WING ATTACHMENT TEST

Although the aft tube fitting of the C⁴Q design is quite robust, the wing attachment tabs, unlike those for the CATM-9M configuration, are not continuous. Also, the wing attachment is a primary structural element. Therefore, testing the wing-to-missile-body attachment method was worthwhile. While not a composite material issue, this effort was needed to ensure structural adequacy. Appendixes M and N present the pertinent test plan and report, respectively.

FATIGUE TEST

The purpose of the fatigue test was to demonstrate that the C⁴Q blue tube could withstand repeated loading. As such, the unit was mounted in a fixture and wiffle tree arrangement that simulated the bending moment profile and hanger reaction loads on the missile. The spectrum of positive and negative accelerations encountered at the F/A-18C/D wing tip station was applied to the missile for a total of 1500 effective flight hours (equivalent to five lifetimes). Prior to the final 300 effective flight hours, impact damage was imposed upon the missile in the most critical locations. Appendixes O and P provide the test plan and report, respectively.

STIFFNESS (MODAL) TEST

The first torsional and body bending mode frequencies were measured for the all-up round used in the vibration test. The former was 81.9 Hz (the goal was >75 Hz, with no prediction made). The latter was 50.3 Hz (the goal was 50 Hz and the predicted result was 54 Hz). The results were not documented in an official report.

MASS PROPERTIES

Critical mass properties were measured on the vibration test article to confirm that the C⁴Q blue tube was falling within the AIM-9M envelope. While no report was prepared, Table 1 provides the results, all of which were within AIM-9M limits.

TABLE 1. Mass Properties.

	Weight, lb	Longitudinal Center of Gravity	Pitch Moment of Inertia, lb-in ²
AIM-9M range	183.6 to 194	60.8 to 62.1	210,600 to 223,200
C ⁴ Q blue tube results	190.7	61.6	219,737

VIBRATION TEST

The captive carriage vibration environment and its effect on composite rocket motors are areas for which little prior history exists. As a consequence, the C⁴Q blue tube was subjected to 300 equivalent flight hours of vibration. The profile, which was based on data collected in an AIM-9M environmental test round, was driven primarily by the F/A-18C/D. Therefore, these conditions represent the environment that the C⁴Q blue tube will experience. After being subjected to vibration, the blue tube was tested in the worst-case bending moment (the Mk 84 bomb release) to verify its residual strength. Appendixes Q and R provide the vibration test plan and report, respectively.

BENDING TEST AFTER VIBRATION

The vibration testing produced evidence of internal delamination or anomalies near the forward hanger at approximately 0.060 inch beneath the surface. The indications, while small, were numerous. So, a test of the residual strength of the composite tube was in order. The all-up-round vibration article was modified into a bending test unit, which was loaded to failure. The purpose was to establish that the effects of the vibration test and the resultant anomalies were not severe enough to negatively influence the airworthiness of the C⁴Q blue tube. Appendixes A and S provide the test plan and report, respectively.

BENDING TEST WITH IMPACT DAMAGE

Impact was imparted with sufficient energy to cause visible damage at the two most critical locations of the blue tube. The results showed a positive margin after the inclusion of knockdowns for hot/wet conditions. Appendixes A and T provide the test plan and report, respectively.

THERMAL SHOCK AND TEMPERATURE, ALTITUDE, AND HUMIDITY TESTS

Tests were conducted to replicate the thermal shock associated with high-temperature storage conditions followed by high-altitude flight, as well as the temperature, altitude, and humidity cycles experienced during aircraft operations. This effort involved using some remnants of the C⁴Q blue tube previously used to support the first bending test (room temperature, dry conditions). The primary specimen, a 5-inch-diameter by 6-inch-long section, was subjected to the aforementioned environments.

To isolate the results of the proposed environments, a secondary specimen, a 1-inch-long section cut from the primary, underwent thermal shock testing only.

In the thermal shock profile, which was performed per Method 503.2 of MIL-STD-810, the temperature ranged from -65°F to +165°F over a 1-minute time period, with the cycle repeated three times.

The temperature, altitude, and humidity testing was conducted in accordance with Method 520.1 of MIL-STD-810. Ten cycles were performed under the following conditions: temperature varied from -55 to +75°C, altitude ranged from 0 to 75,000 feet, and relative humidity varied from 0 to 75%.

Sections of the test specimens were mounted, polished, and photo-micrographed. The results indicated no apparent adverse effects or damage. Appendix U documents this effort.

PRE-FLIGHT PROOF TEST

To ensure the quality of manufacturing and assembly, all five flight units were subjected to a one-time proof load of 6014 lbf. The load was applied and distributed by utilizing the same wiffle tree fixture constructed for the fatigue series. All five units successfully passed this test. Appendixes V and W document the test plan and results, respectively.

BENDING TEST UNDER HOT/WET CONDITIONS WITH KEVLAR OVERWRAP REMOVED

Prior to the bending test under hot/wet conditions with the Kevlar overwrap removed, blue tube Serial Number 015 had been subjected to a total of 8.88 hours of captive carry on the F/A-18C/D on both the pylon and wing tip stations. However, a post-flight visual inspection revealed "separations" between the Kevlar fibers on the exterior overwrap. While an ultrasonic inspection had also been performed, no indications of the aforementioned condition were observed because the separations were confined to the outermost hoop-direction Kevlar fibers, which run parallel to the line of sight used in the inspection technique. So, a test was conducted to demonstrate the structural adequacy of the blue tube with portions of the Kevlar overwrap removed to simulate the worst-case environmental factors of hot/wet bending combined with a maximum bending load on the missile body. The first stage entailed conditioning the blue tube in an environment with 85% relative humidity at 130°F (54.4°C). The second phase involved heating the blue tube to a temperature of 215°F (101.7°C). Next, the load was increased to the yield and then allowed to return to zero. Finally, the load was increased to ultimate and the unit continued to undergo exposure until failure occurred. The reader should note that the outer Kevlar layer is incorporated to help protect the inner load-bearing graphite/epoxy structure from both impact and thermal environments. The layer is not relied upon for structural integrity. Appendix X provides the test plan and results.

SUMMARY

The ground testing conducted in support of C⁴Q meets only the minimum effort needed to obtain a local flight clearance for demonstration purposes. As a consequence, the blue tube does not satisfy all of the requirements for a Fleet certification of a composite rocket motor. However, the ground testing did demonstrate that the C⁴Q blue tube is capable of withstanding captive carriage loads and environments. In fact, the outcome indicated that the composite structure was robust and could tolerate the conditions under which it will operate during service. In addition, all margins of safety were positive. The lowest margin of safety resulted from the maximum bending moment after introducing impact damage to the two most

sensitive locations and testing at maximum service temperature after moisture conditioning. Based on these results, the principal investigator recommended that the C⁴Q blue tube be cleared to the full limits of the Naval Air Training and Operating Procedures Standardization (NATOPS) and Tactical Manuals (TACMAN) of the F/A-18C/D to begin the accumulation of real flight hours.

Upon the essential ground testing being completed, the results were collected and documented. Table 2 presents a summary of the results.

TABLE 2. Summary of Ground Test Results.

Test	Margin of Safety	Comments
Bending (room temperature and dry conditions)	+0.77	With increased loading factors as shown [× (1.5 FS); × (1.25 hot/wet); × (1.25 impact)].
Bending (impact damage and hot/wet conditions)	+0.08	Test at 85% humidity weight equilibrium and 215°F [× (1.5 FS)].
Forward hanger	+1.60	Failure in metal hanger lip [× (1.5 FS)].
Middle hanger (modified design)	+0.19	With increased loading factors as shown [× (1.5 FS); × (1.25 hot/wet); × (1.25 impact)].
Middle hanger (modified design) (with released pad)	+0.16	Indication of small change from prior test [× (1.5 FS); × (1.25 hot/wet); × (1.25 impact)].
Aft hanger	+1.09	Failure in metal hanger lip [× (1.5 FS)].
Wing attachment fitting	+0.55	Failure in AIM-9M wing [× (1.5 FS)].
Fatigue test	N/A	150-flight-hour life recommended, 300 flight hours of life possible, 1500 EFH total test time.
Stiffness	N/A	50.3 Hz measured/50 Hz goal.
Mass properties	N/A	Within middle of AIM-9M range for weight, center of gravity, and pitch moment of inertia.
Vibration	N/A	No failure to perform function. NDI indication of small internal anomalies about 1/4 in ² .
Post-vibration bending	+0.54	With increased loading factors as shown [× (1.5 FS); × (1.25 hot/wet); × (1.25 impact)].
Bending (impact damage)	+0.45	With increased loading factors as shown [× (1.5 FS); × (1.25 hot/wet)].
Thermal shock	N/A	-65°F to +165°F (no resin degradation or micro-cracking).
Thermal cycling	N/A	-55° to +75°C, 0-75% humidity, 0- to 30,000-foot altitude.
Pre-flight proof test	N/A	Proof load of 6014 lbf.
Bending (hot/wet conditions and overwrap removed)	+0.39	Test at 85% humidity weight equilibrium and 215°F [× (1.5 FS)].

FS = factor of safety, EFH = effective flight hours.

FLIGHT CLEARANCE PACKAGE AND DOCUMENTATION

A flight clearance request package encompassing the following documents was submitted on January 2001 to NAWCWD, China Lake, California, and NAVAIR Headquarters, AIR-4.3T, Patuxent River, Maryland, for review and approval.

1. Flight Clearance Request
2. Draft Flight Clearance Message
3. Design Criteria for the C⁴Q Blue Tube
4. Structural Adequacy of the C⁴Q Blue Tube
5. IMTTP C⁴Q Composite Blue Tube Ground Test Report
6. C⁴Q Proof Test Plan
7. Complete C⁴Q Blue Tube Drawing Package (Including Tooling Drawings)

The China Lake Aircraft Review Board Chairman signed the final flight clearance in May 2001.

FLIGHT TESTING

Five of the 19 composite blue tubes fabricated were designated as flight assets. These units were originally cleared to fly on F/A-18C/D missile stations 2 and 8 for a 5-month period, subject to renewal (Commander Naval Air Systems Command [COMNAVAIRSYSCOM] 4.0P, Patuxent River, Maryland, Naval Message DTG 142000Z of May 2001). As confidence continued to grow, the flight clearance was subsequently expanded and approved for the composite blue tubes to be loaded on the wing tip and on stations 1 and 9 and, later, to include carrier suitability testing (simulated catapult launches and arrested landings) per COMNAVAIRSYSCOM 4.0P, Patuxent River, Maryland, Naval Message DTG 272008Z of June 2002).

The flight units were handled in the same manner as any other CATM. After each flight, a visual inspection by the test engineer and project director was conducted, followed by ultrasonic examination performed by the China Lake Test Squadron NDI Laboratory. The program goal was to obtain at least 30 hours on two or three units; however, achieving up to 150 hours on each unit was desirable. In 2004, the number of ultrasonic inspections were reduced based on the historical performance and satisfactory results of the visual examinations, a situation that required an amendment to the flight clearance (COMNAVAIRSYSCOM 4.0P, Patuxent River, Maryland, Naval Message DTG 242024Z of February 2004).

As flights became difficult to schedule, focus was redirected toward accumulating flight hours on the high-flight-time assets (blue tube Serial Numbers 012 and 013). The data recorded from each flight included the following parameters: velocity; acceleration (g); total flight time; and any special event such as adjacent store releases, rolling pullouts, etc. Table 3 is the flight log summary, for a total of 109 cumulative flight hours.

TABLE 3. Flight Log Summary.

Blue Tube Serial Number	Captive Carriage EFH	Arrested Landings	Simulated Catapult Launches	Notes
012	63.97			Flights conducted at China Lake.
013	30.79	23	6	Carrier suitability testing conducted at Patuxent River; results reported via COMNAVAIRSYSCOM Patuxent River, Maryland, 4.11.3, Naval Message DTG 291459Z, October 2003.
014	4.24			
015	8.88			Unit removed from flight pool for an additional hot/wet bending test with Kevlar overwrap removed.
016	1.5			

SUMMARY OF LESSONS LEARNED

During the test phase, the investigators encountered and overcame several obstacles related to using composite rocket motors in a captive carriage environment. The following paragraphs describe some of the most significant lessons learned.

The primary failure mode for the rocket motor was compressive stress caused by bending moments experienced during captive carriage. The bending moment, rather than pressure or stiffness, was the principal factor in determining the case wall thickness. In the initial design phase of the program, representative compressive strength parameters for the composite laminate were not available in previously existing test data. Furthermore, the analytical prediction code indicated unusually low compression strength values. Thus, representative 5-inch-diameter blue tubes were fabricated and then tested to supply actual transverse compressive material properties. Five-inch bottles were also tested for impact and pressurization to supplement the existing material database. The results of this supplemental effort both confirmed and correlated well with the predicted compressive strength values and emphasized the importance of testing flight-representative hardware and adopting industry-developed standards.

Results from initial tests indicated that the void contents in the composite blue tubes ranged between 5 to 9%. After some research and troubleshooting, the investigators discovered that the sizing (or primer coating) on the fiber had been changed by the manufacturer to a water-based system. This feature made wetting of the fibers with resin more difficult. To compensate for this anomaly, a modification to the filament winder was made. This change entailed a series of bars that broke up the sizing before the resin bath; then, afterwards, the resin was kneaded into the tow bundle. The blue tubes manufactured according to this process yielded void content values as low as 1.5%. In fact, the new method consistently produced the mechanical properties required to satisfy the critical compressive strength test.

Earlier concerns of any unseen impact damage were considerably mitigated. The force required to produce clearly visible external damage is 18 to 20 ft-lb. The outcome of the bending test after imparting the impact damage demonstrated that the resultant internal impairment was not severe enough to prevent the C⁴Q blue tube from sustaining ultimate loads. The impact-damaged areas were also easily detected with pulse-echo ultrasound NDI, which is currently in Fleet service. The scalability of this response to

impact damage was not explored. Further study is required to identify actual damage levels in order to provide the Fleet with guidelines pertaining to disposition, inspection technique, and frequency. Also needed is a characterization, or inspection standard, for the size and lay-up of a specific composite rocket motor. While the test results reflect only those for the blue tube configuration, they do provide confidence that other systems can still be effective with impact damage.

The fatigue life of the composite tube was quite adequate. For example, after 1200 effective flight hours of testing, impact damage was introduced to the structure in two critical areas; and then the effort resumed for another 300 hours. The blue tube continued to sustain the fatigue spectrum until the test was terminated (spectrum loading from -15 to +22 g). There were, however, indications of interlaminar anomalies; and the impaired area had increased. This outcome illustrates the need to characterize the fatigue behavior of the composite structure for future weapon certification programs.

The wound-in hanger pad concept met the loading and vibration requirements of captive carriage. Although other variations of the design may be more conducive to low-cost production methods, the success of this particular design for the C⁴Q blue tube illustrates that attaching hardware to composite cases can be achieved by utilizing wound-in fittings. Taking this approach can result in potentially lower costs than using secondarily attached hardware. Testing confirmed that the mechanically locked-in hanger pad does not depend upon the bond between the composite and the metal to meet the load requirements.

Blue tube Serial Number 015 had been subjected to a total of 8.88 hours of captive carriage flight on the F/A-18C/D on both the pylon and wing tip stations when what were initially identified as "cracks" in the airframe exterior were discovered during a post-flight visual inspection. Further investigation revealed that the "cracks," which were confined solely to the exterior overwrap, were actually separations between the Kevlar tows and did not penetrate the structural fibers. An ultrasonic inspection provided no indications of this condition because the separations were confined to the outermost hoop-direction Kevlar fibers, which run parallel to the line of sight used in the inspection technique. Blue tube Serial Number 015 was pulled from the flight pool, and all five flight assets were essentially "grounded" until the Materials Engineering Branch conducted a detailed evaluation (see Appendix Y for the results). A careful visual examination revealed this condition only in blue tube Serial Numbers 014 and 015. Several factors contributed to this condition and include the following:

1. The surface finish of the composite tubes was somewhat variable. As a consequence, resin-rich areas occurred on the outermost layer of composite tubes.
2. The half hoop of Kevlar overwrap (one winding pass along the length of the tube) was wound on top of the already cured carbon fibers and the moisture barrier, a condition that compromised the cohesive bond between the two fiber systems.

In order to resume flying the remaining units, the structural adequacy of the blue tube had to be demonstrated. As such, blue tube Serial Number 015 was subjected to a ground qualification test that involved the worst-case environmental factors of hot/wet exposure combined with a maximum bending load on the missile body. In addition, portions of the Kevlar overwrap were removed. As required, the conditions were 85% relative humidity at 130°F for 36 days. Even with portions of the overwrap removed and the moisture barrier compromised, the airframe, when exposed to the maximum bending load, absorbed minimal moisture (0.1 pound) and positive safety margins resulted.

The findings from this situation resulted in a process change that was later implemented in a related composite airframe program, the Rolling Airframe Missile (RAM) pre-planned product improvement. The moisture barrier between the carbon and Kevlar fibers was omitted and peel ply tape was applied over the Kevlar to allow the excess resin to be stripped off, leaving a "ready-for-paint" surface

finish. The fabrication just described has since alleviated any “separations” in the Kevlar overwrap and is common in private industry as well.

On a final note, in the manufacturing of the 19 blue tubes, a moisture barrier was placed between the carbon structural fibers and the Kevlar overwrap in an attempt to protect the propellant. However, this placement caused a natural delamination in the airframe. In addition, results from the hot/wet conditioning (with and without the moisture barrier intact) indicated that the airframe absorbed little to no moisture, further evidence that incorporating the moisture barrier externally to the structural fibers provides little benefit. Recommendations for follow-on composite motor efforts include inserting the moisture barrier between the insulation and composite case instead.

REFERENCES

1. American Society of Testing Materials. *Standard Test Methods for Inplane Sheer Properties of Hoop-wound Polymer Matrix Composite Cylinders*. ASTM, 2001. (ASTM-D5448.)
2. American Society of Testing Materials. *Standard Test Methods for Transverse Compressive Properties of Hoop-wound Polymer Matrix Composite Cylinders*. ASTM, 2001. (ASTM-D5449.)
3. American Society of Testing Materials. *Standard Test Methods for Transverse Tensile Properties of Hoop-wound Polymer Matrix Composite Cylinders*. ASTM, 2001. (ASTM-D5450.)
4. Department of Defense. *Department of Defense Handbook, Polymer Matrix Composites, Volume 1, Guidelines for Characterization of Structural Materials*. Washington, DC, DOD, 23 January 1997. (MIL-HDBK-17-1E, publication UNCLASSIFIED.)

NOMENCLATURE

ASTM	American Society for Testing Materials
C ⁴ Q	Composite Case Captive Carry Qualification
CATM	captive air training missile
COMNAVAIRSYSCOM	Commander Naval Air Systems Command
EFH	effective flight hours
EMD	Engineering and Manufacturing Development
FS	factor of safety
ICAN	Integrated Composites Analyzer
IM	Insensitive Munitions
IMTTP	Insensitive Munitions Technology Transition Program
NASA	National Aeronautics and Space Administration
NASTRAN	NASA Structural Analysis
NATOPS	Naval Air Training and Operating Procedures Standardization
NAVAIR	Naval Air Systems Command

NAWCWD	Naval Air Warfare Center Weapons Division
NDI	non-destructive inspection
RAM	Rolling Airframe Missile
TACMAN	Tactical Manuals

Appendix A
COMPOSITE CASE CAPTIVE CARRY QUALIFICATION
(C⁴Q) BLUE TUBE BENDING TEST PLAN

(This page intentionally left blank.)

1.0 INTRODUCTION

This test plan describes the requirements of the Insensitive Munitions Technology Transition Program (IMTTP) Composite Case Captive Carry Qualification (C⁴Q) composite tube structural verification tests. Only tube body bending testing will be described in this test plan.

2.0 OBJECTIVE

The primary purpose of this bending test is to verify that design requirements are met. This test plan provides the overall instructions for conducting tube bending moment testing of the IMTTP 5.0-inch composite tube.

3.0 TEST DESCRIPTION

The test requirements, as defined by the loads given in the design, will be demonstrated via proof (yield) and ultimate testing.

Yield (proof) testing consists of applying limit loading (69,200 in-lb moment at missile station 44.0 inches) times a 1.15 factor for a total applied bending moment of 79,580 in-lb. Due to this test being performed at room temperature, dry, and without impact damage, the applied loading is then increased by the knockdown factors used in the design. The factors are 1.25 for hot/wet and 1.25 for impact. This results in an applied moment of 124,300 in-lb. This value is denoted as "composite yield load."

Ultimate testing consists of applying limit loading (69,200 in-lb moment at missile station 44.0 inches) times a 1.5 factor for ultimate (plus 1.25 and 1.25 for the knockdowns), resulting in a total applied bending moment of 162,200 in-lb. This value is denoted as "composite ultimate load."

The success criteria are as follows. Yield testing shall be considered successful if the case withstands proof moment without anomalous behavior that would be indicative of its inability to perform its intended use. This shall be determined by inspection (visual and dimensional) and comparison of data (strains and deflections) with other composite case designs.

Ultimate bending moment testing shall be considered successful if the case fails in the predicted manner at 1.5 or higher load factor.

3.1 TEST ARTICLE DESCRIPTION

The test article consists of an IMTTP C⁴Q composite tube (Serial Number 001), as described in drawing number A476200D-126 (C⁴Q FIRST CURED ASSY) and shown here in Figure A-1. (Note: all figures can be found at the end of this test plan.) The test article consists of the warhead section and

composite tube only. No wing ribs or hangers are used. The cases are wound by using IM-7 graphite fiber embedded in an epoxy resin. The graphite/epoxy winding lay-up consists of helical (14-degree), axial (0-degree), and hoop (90-degree) layers. A Kevlar overwrap hoop layer is used for protection. A 3/4-inch hole for a pin is added as shown in Section B-B of Figure A-1. The holes for the forward hanger are opened up to 1/2-inch clearance holes (see section C-C of Figure A-1).

3.2 TEST FACILITIES

The test facility is located at the Code 476300D static frame test facility. The test equipment for this bending moment test consists of a hydraulic load jack, load cell, strain gages, a displacement transducer, and signal conditioning and recording equipment. The test fixturing to be used for this test will include two tie-down collars (one with a 0.75-inch pin at 12 o'clock) and a forward hanger replacement block. The layout of the test fixtures is shown in Figure A-2.

4.0 INSTRUMENTATION AND DATA REQUIREMENTS

The instrumentation requirements for these tests will be the same for both proof (yield) and ultimate tests. All strain gages are 45-degree rectangular rosette (MM CEA-06-125 UR-350) gages. The placement of the instrumentation is shown in Figure A-3.

The accuracy requirements for the instrumentation through the data recording system shall be as shown in Table A-1.

TABLE A-1. Accuracy Requirements for Instrumentation.

Strain Gages	$\pm 0.08\%$ strain
Load Cell	± 10.0 lb
Displacement Potentiometers	± 0.01 inch

The test data shall be reduced and plotted at five samples per second. Two copies of all printouts and plots are required. The digital listings (printouts) will have the strain and displacement as a function of load. Digital plotting will be in the format provided in Table A-2.

TABLE A-2. Digital Plotting Format.

Instrumentation	Abscissa	Ordinate
Load (shear load) cell	Time, seconds	0 to 20,000 lb
Strain gages (SG1-SG12)	0 to 20,000 lb	-3.50 to 3.50%
Displacement potentiometer (DP1)	0 to 20,000 lb	0 to 0.70 inch

5.0 TEST PROCEDURE AND SETUP

The types of gages are noted in Figure A-3. These gages must be protected and thermal compensation is not required. Prior to the tests, the test director will define selected priority data, which will be immediately processed and reviewed prior to proceeding with the testing.

The general test procedures are as follows:

1. Attach the load actuator stinger to the forward hanger replacement block.
2. Place all assembly into the static test frame and assemble composite tube to the forward hanger replacement block.
3. Attach the aft collar tie assembly to the aft section of the composite tube.
4. Align the forward collar and insert the pin through the collar and tube.
5. Fit position displacement potentiometer according to Figure A-2.
6. Connect all instrumentation.
7. Take pretest photographs of the test setup.
8. Slowly raise the load to 1000 pounds and then lower the load back to zero. Observe strain gage and displacement readings. Verify all instrumentation is operating properly.
9. Once correct instrumentation operation has been confirmed, start recording data and begin to raise the load in accordance with Figure A-4. Note the steps in the loading to allow for instrument stabilization.
10. Turn off instrumentation and disconnect all lead wiring and fixtures.
11. Note all anomalies during and after the testing.
12. Take post-test photographs of the test setup.
13. Remove test article (see Sections 5.1 and 5.2).

5.1 TEST PRECAUTIONS

The composite tube will be placed in an isolated area during the test. Hazardous flying debris is expected during the ultimate test and all precautions shall be taken to avoid exposure to the debris. Extreme care should be taken in handling the remains of the case after the test is completed. All the bending moment tests must comply with all Code 476300D safety requirements.

5.2 TEST ARTICLE DISPOSITION

The composite tube will be post inspected after proof (yield) and ultimate tests by Code 476J00D personnel. The tube will be delivered to Code 476J00D for sectioning into coupons and cylindrical test articles after the ultimate test.

6.0 SUMMARY

Following each test, a summarized report shall be drafted describing the test and the results. Pertinent diagrams and graphs shall be included.

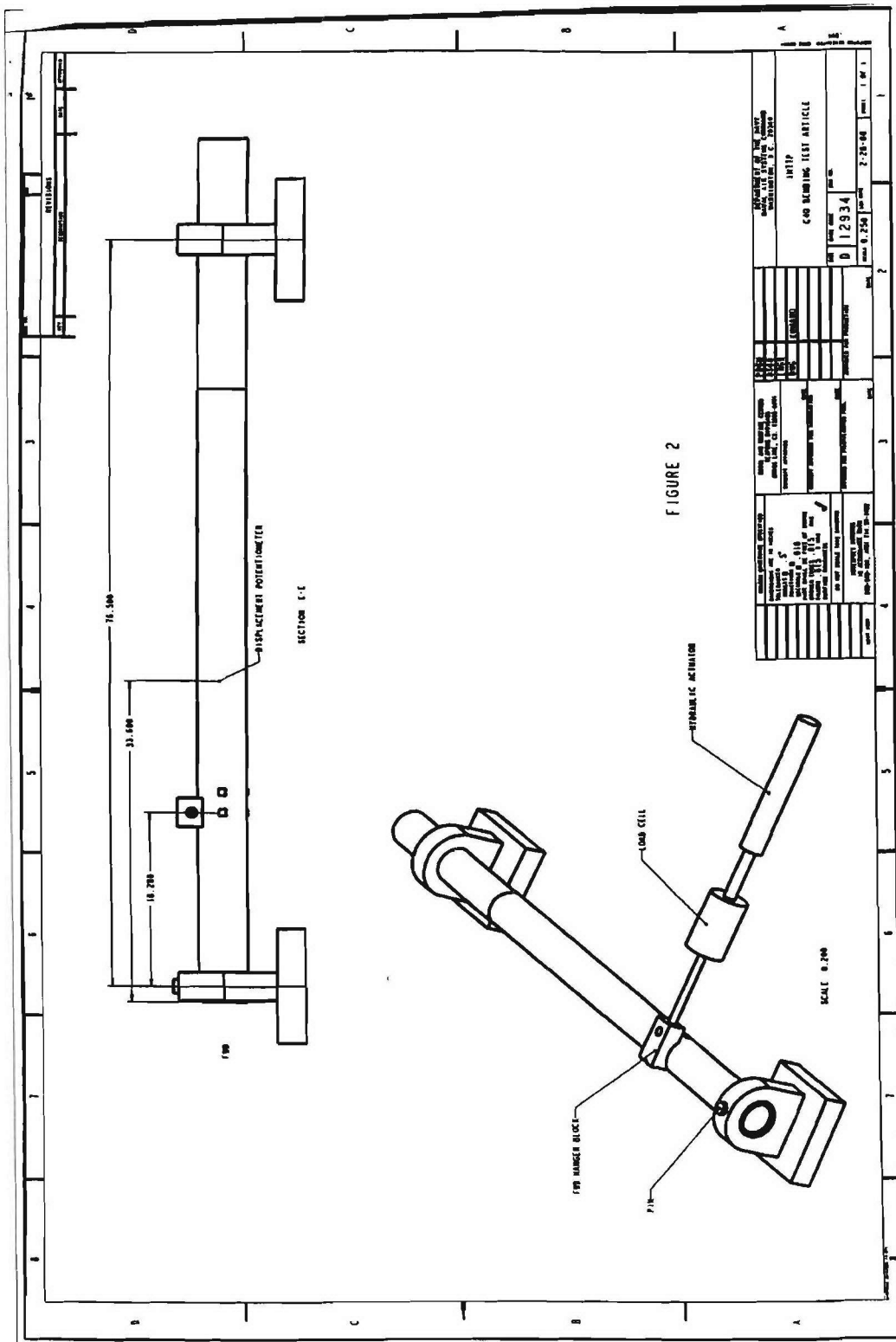

FIGURE A-2. Layout of Text Fixtures.

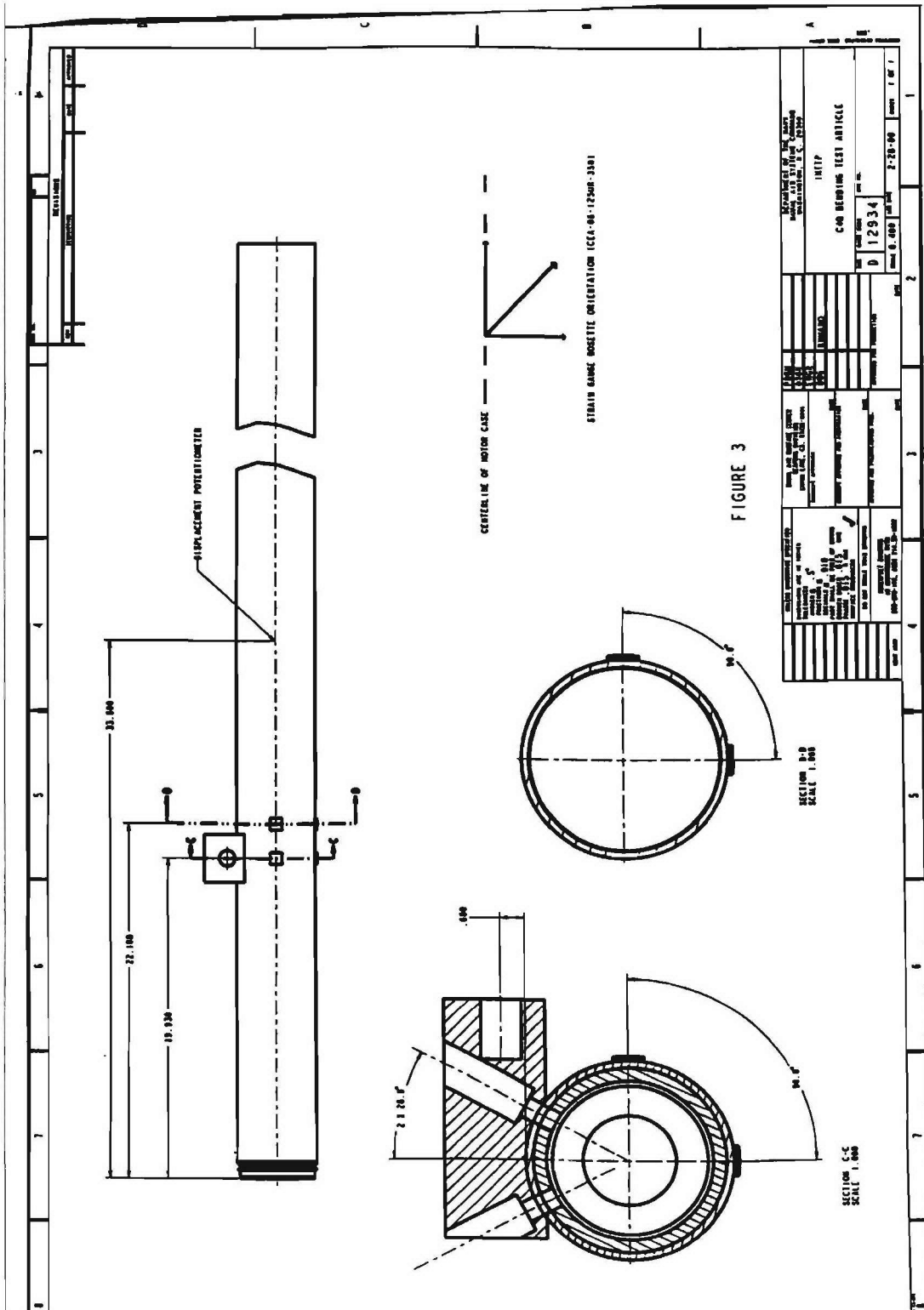
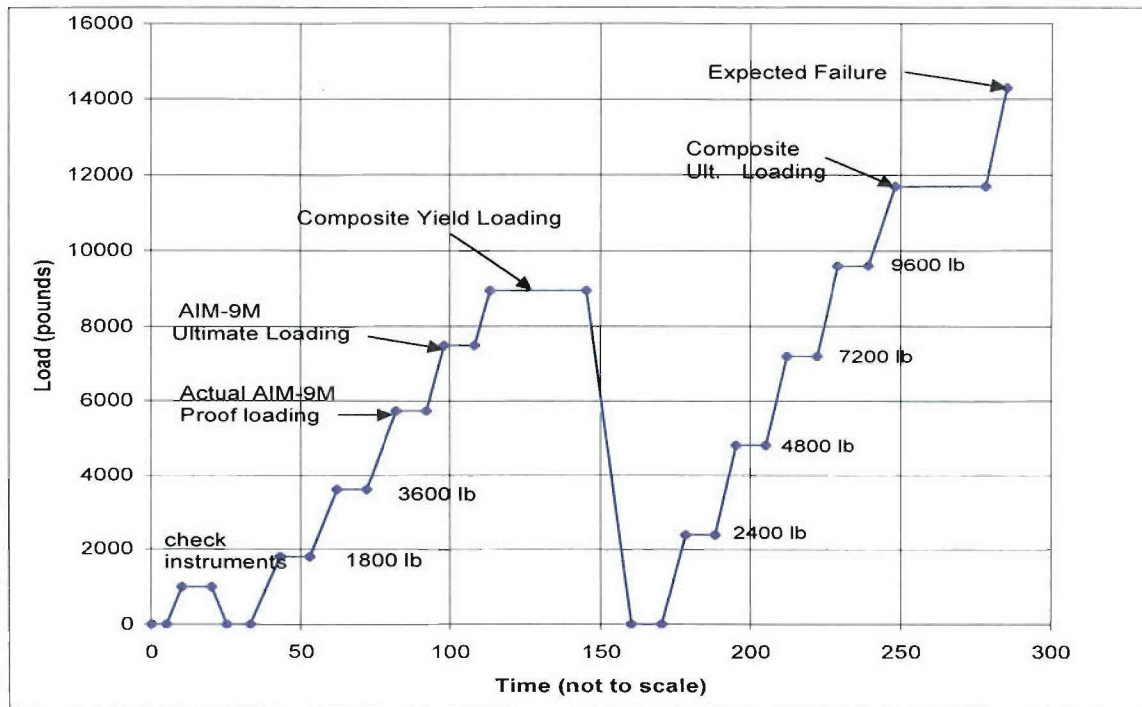

FIGURE A-3. Instrumentation Placement.



	Applied Load, lb	Resulting Moment, in-lb	Strain, inches/inch	Maximum Displacement, inches
Instrument test	1,000	13,870	0.000241	0.044
Actual yield load	5,738	79,586	0.001383	0.250
Actual ultimate load	7,490	103,886	0.001805	0.327
Composite yield load	8,962	124,303	0.002160	0.391
Composite ultimate load	11,700	162,279	0.002820	0.510
Predicted failure	14,300	198,341	0.003446	0.623

FIGURE A-4. Load Schedule.

Appendix B
COMPOSITE CASE CAPTIVE CARRY QUALIFICATION (C⁴Q) BLUE TUBE
TEST REPORT FOR BENDING TEST AT ROOM TEMPERATURE
UNDER DRY CONDITIONS WITHOUT IMPACT DAMAGE

(This page intentionally left blank.)

CONTENTS

Test Description	B-5
Introduction.....	B-5
Test Specimen.....	B-5
Loading Condition.....	B-5
Analysis of Loading.....	B-7
Three-point Bending Development.....	B-7
Analysis of Structural Response.....	B-8
Laminate Properties.....	B-8
Tube Structural Analysis.....	B-9
Test Results	B-11
Yield Test.....	B-11
Ultimate Test.....	B-14
Summary.....	B-17

Figures:

B-1. All-up-round (AUR) Structural Layout.....	B-5
B-2. Fixtures (View 1).....	B-6
B-3. Fixtures (View 2).....	B-6
B-4. Bending Test Moment Diagram	B-7
B-5. Yield Test Load History.....	B-12
B-6. Compressive Strain at Forward Hanger (Estimated From Gage 2).....	B-12
B-7. Yield Load Test Displacement.....	B-13
B-8. Ultimate Test Load History.....	B-14
B-9. Ultimate Load Test Displacements.....	B-15
B-10. Ultimate Load Test Selected Strain Data	B-15
B-11. Gage 2 (View 1)	B-16
B-12. Gage 2 (View 2)	B-16

Tables:

B-1. Laminate Failure Criteria.....	B-8
B-2. Laminate Stress–Strain Relations, psi	B-9
B-3. Predicted Structural Response	B-11

(This page intentionally left blank.)

TEST DESCRIPTION

INTRODUCTION

The Composite Case Captive Carry Qualification (C⁴Q) blue tube bending test 1 is a full-scale structural test of the composite blue tube in bending. The goal was to simulate the worst-case bending load on the missile body. This test, in combination with other testing, is intended to demonstrate the structural adequacy of the C⁴Q blue tube design. Test 1 is performed on a full-scale specimen at room temperature, without heat, moisture, or impact damage. The test yielded a margin of safety (M. S.) for bending of the tube of +0.77. This was with a 1.5 factor of safety for ultimate (with increased load requirements for the knockdown factors of 1.25 and 1.25).

TEST SPECIMEN

For reference, Figure B-1 shows the basic structural layout of the CATM-9M with the C⁴Q hardware. The test article omits the guidance and control section (GCS), wings, fins, and hangers. The inert fill was omitted as well. None of these items were considered necessary for this test. The forward hanger bolt holes were enlarged and a locating pin hole added per the instructions in the test plan. This allowed sufficient load to be applied to the composite case for it to fail in the composite section without failing at the forward hanger or spinning in the fixture.

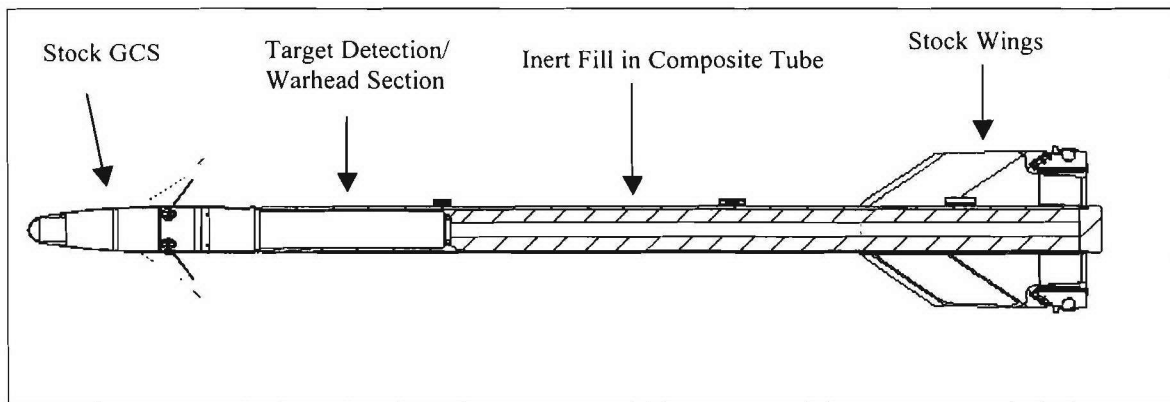

FIGURE B-1. All-up-round (AUR) Structural Layout.

LOADING CONDITION

The specimen was loaded in a three-point bending fixture. The locations of the end clamping fixtures and load application point were designed to approximate the moment diagram during the worst-case bending maneuver (the Mk 84 bomb release). A block-like replacement for the forward hanger was used to simulate the load transfer through the forward hanger. This reduced the risk of forward hanger failure to prevent an invalid test and wasted specimen. The loading was raised to yield level and returned to zero in order to confirm that no permanent deformation occurred. The loading was then raised until it

produced failure. The fixtures and loading sequence can be seen in detail in the test plan (Appendix A) and in Figures B-2 and B-3.

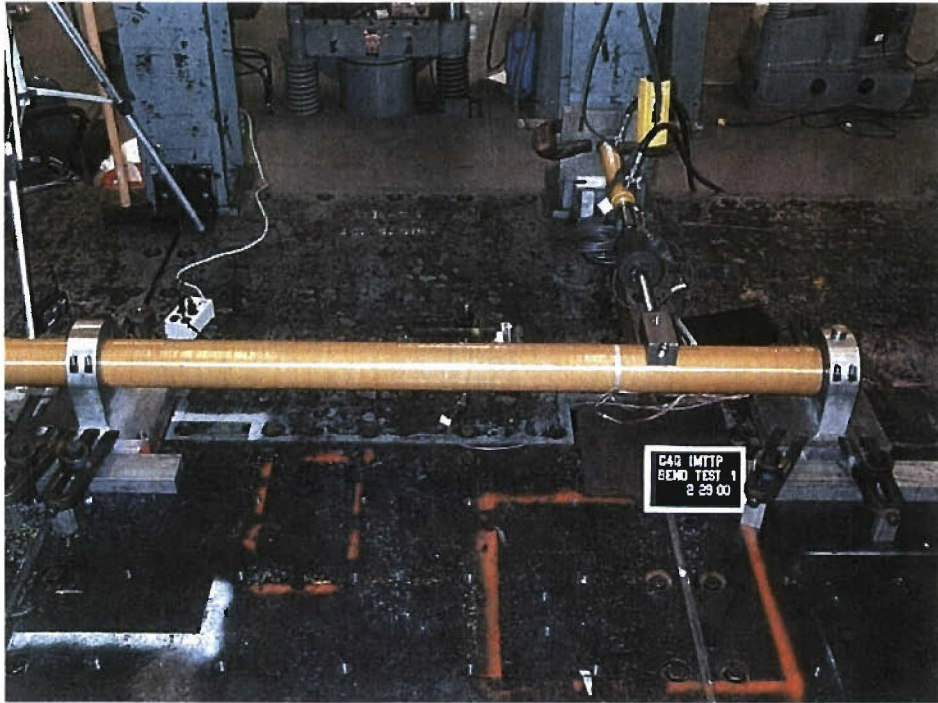

FIGURE B-2. Fixtures (View 1).

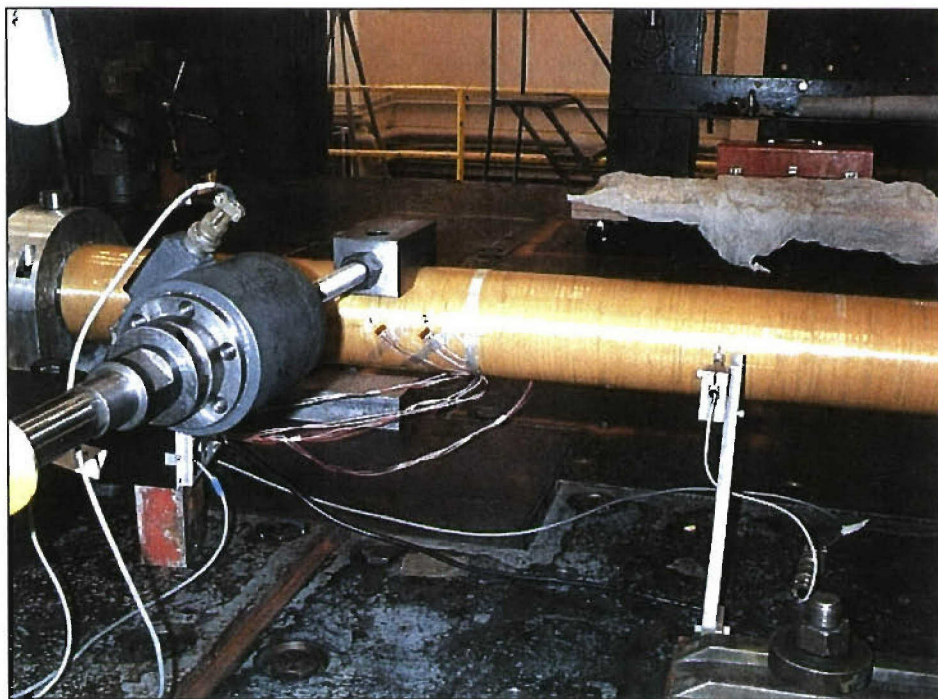

FIGURE B-3. Fixtures (View 2).

ANALYSIS OF LOADING

THREE-POINT BENDING DEVELOPMENT

The development of the three-point bending fixture and loading values is based on the assumption that the composite tube will fail at or near the forward hanger where the bending moment is most severe. The assumption of simple supports is used due to the geometry of the clamps and the clearance with the tube. The clamp locations were estimated by fitting a triangular moment diagram (typical for three-point bending) onto the maximum moment envelope. The peak at the forward hanger is for the Mk 84 release condition (worst-case limit load). Figure B-4 shows the results. Note that the locations of the base corners of the triangle correspond to the clamping locations.

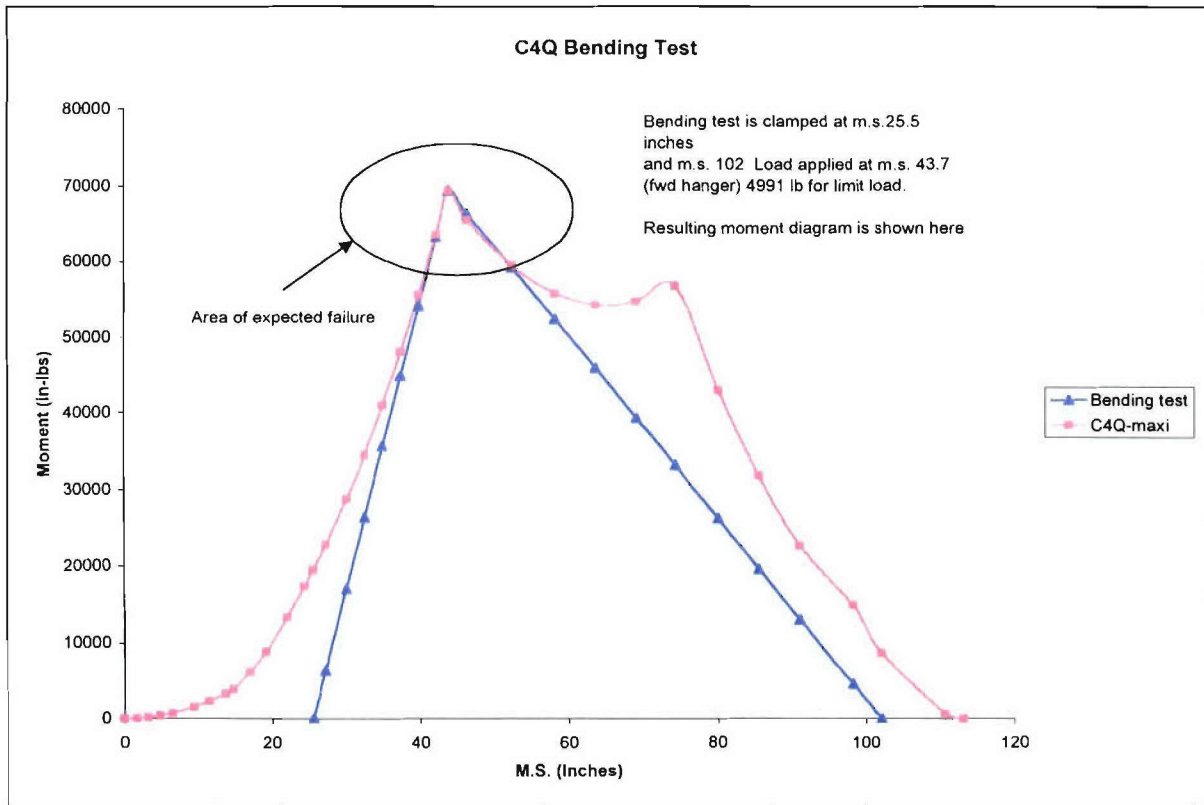

FIGURE B-4. Bending Test Moment Diagram.

The magnitude of the needed applied load was determined by working backward from the triangular moment diagram.

The shear in front of the load is equal to moment divided by the distance from front clamp to load ($[(69,200 \text{ in-lb}) / (18.2 \text{ inches})] = 3800 \text{ pounds}$). The shear behind the load is equal to negative moment divided by the distance from load to the back clamp ($-[(69,200 \text{ in-lb}) / (58.3 \text{ inches})] = -1190 \text{ pounds}$). The

total applied load is 4990 pounds (3800 pounds + 1190 pounds). This value is for the AIM-9M limit load condition. Therefore, Equations B-1 and B-2 apply.

$$\text{Yield Load} = 4990 \times 1.15 = 5738 \text{ pounds} \quad (\text{B-1})$$

$$\text{Ultimate Load} = 4990 \times 1.50 = 7485 \text{ pounds} \quad (\text{B-2})$$

The composite materials have knockdown factors to cover the degradation due to impact damage and hot/wet operating environments. The knockdown factors are 1.25 for impact and 1.25 for hot/wet. Because bending test 1 does not pre-condition the composite to those reduced strengths, the test loads must be higher to demonstrate the adequacy of the tube. Later tests will demonstrate the tube under these adverse conditions. Equations B-3 and B-4 apply.

$$\text{Composite Yield Load} = 5738 \text{ pounds} \times 1.25 \times 1.25 = 8960 \text{ pounds} \quad (\text{B-3})$$

$$\text{Composite Ultimate Load} = 7485 \text{ pounds} \times 1.25 \times 1.25 = 11,700 \text{ pounds} \quad (\text{B-4})$$

ANALYSIS OF STRUCTURAL RESPONSE

Some of the analysis shown here is taken from the *Structural Adequacy of C⁴Q Composite Training Missile for F/A-18A/B/C/D*, Memo 476200D/006, dated 3 February 2000. These are repeated here for convenience. This analysis was performed here to provide reference strains and displacements to use for comparison with the test data. The different load levels were analyzed by assuming linear response until ultimate loads were reached. This is not unreasonable for a composite structure, especially considering the results are only used for reference.

LAMINATE PROPERTIES

The laminate properties were calculated using the "ICAN" laminate code. These data were developed for the C⁴Q lay-up with a fiber volume of 58% and a void content of 3%. ICAN produced the data shown in Tables B-1 and B-2.

TABLE B-1. Laminate Failure Criteria.

Load Type	Stress, ksi	Failure Mode	Ply No.	Theta	Material System
SCXXT	305	SL11T	4	0	IM7-EPON
SCXXC	61.1	SL11C	4	0	IM7-EPON
SCYYT	130	SL11T	13	90	IM7-EPON
SCYYC	26.0	SL11C	13	90	IM7-EPON
SCXYS	10.9	SL11C	10	14	IM7-EPON

TABLE B-2. Laminate Stress–Strain Relations, psi.

	-1-	-2-	-3-	-4-	-5-	-6-
1	<i>1.77E+07</i>	8.66E+05	5.46E+05	0.00E+00	0.00E+00	-9.01E-03
2	8.64E+05	7.61E+06	5.78E+05	0.00E+00	0.00E+00	-2.70E-01
3	5.46E+05	5.78E+05	1.38E+06	0.00E+00	0.00E+00	9.16E-04
4	0.00E+00	0.00E+00	0.00E+00	3.52E+05	1.88E-03	0.00E+00
5	0.00E+00	0.00E+00	0.00E+00	1.88E-03	4.19E+05	0.00E+00
6	-9.53E-03	-2.70E-01	9.16E-04	0.00E+00	0.00E+00	8.02E+05

TUBE STRUCTURAL ANALYSIS

Tube in Bending

First, the bending compressive stress (σ_c) is determined from the following known data:

Maximum moment (M) = 69,200 in-lb

Outer diameter (D_o) = 5.00 inches

Inner diameter (D_i) = 4.63 inches

Equations B-5 and B-6 apply.

$$I_{yy} = I_{zz} = \frac{\pi}{64}(D_o^4 - D_i^4) = 8.122in^4 \quad (B-5)$$

$$\sigma_{xc} = \frac{Mc}{I_{yy}} = \frac{(69200)(2.5)}{8.122} = 21.3ksi \quad (B-6)$$

The M.S. is calculated with the following data:

1. Whether the knockdowns for impact and hygrothermal are considered additive as it represents the worst-case analysis for the information available at this time.
2. 61.1 ksi allowable for axial compression (Table B-1, row 2).
3. 1.5 factor for ultimate.
4. 1.25 factor for impact damage (estimated until test data are available).
5. 1.25 factor for hygrothermal effects (estimated until test data are available).

Equations B-7 and B-8 apply.

$$M.S. = \frac{61.1}{(1.5)(1.25)(1.25)(21.3)} - 1 \quad (B-7)$$

$$M.S. = +0.22 \quad (B-8)$$

Response at 1000 Pounds

The first step in the loading sequence is 1000 pounds. The step allows us to confirm the instrumentation and test setup are functioning properly.

From the above analysis, the stress in the compression area of the tube at limit load is 21.3 ksi. Limit load corresponds to 4990 pounds. So, assuming linear behavior, the stress at 1000 pounds can be scaled. Equation B-9 applies.

$$\sigma_{1000} = 21.3 \text{ ksi} (1000/4990) = 4.270 \text{ ksi} \quad (B-9)$$

With a modulus (in this direction) of 17.7 Mpsi, the strain at 1000 pounds is as shown in Equation B-10.

$$\epsilon_{1000} = 4270/17.7E6 = 0.000241 \text{ in/in} \quad (B-10)$$

Using Roark's Formulas for Stress and Strain, Table 3, case 1e, the maximum deflection in the tube was determined with Equations B-11 and B-12.

$$X_{\max} = l - \left(\frac{l^2 - a^2}{3} \right)^{\frac{1}{2}} \quad (B-11)$$

$$X_{\max} = 76.5 - \left(\frac{76.5^2 - 18.2^2}{3} \right)^{\frac{1}{2}} = 33.6 \text{ in} \quad (B-12)$$

This suggests that 33.6 inches (from the front clamp) will be a good place for a displacement potentiometer. The expected displacement there at 1000 pounds was determined with Equations B-13 and B-14.

$$\delta_{1000} = \frac{-Wa}{3EI} \left(\frac{l^2 - a^2}{3} \right)^{\frac{3}{2}} \quad (B-13)$$

$$\delta_{1000} = \frac{-1000(18.2)}{3(17.7E6)(8.122)(76.5)} \left(\frac{76.5^2 - 18.2^2}{3} \right)^{\frac{3}{2}} = 0.0436 \text{ in} \quad (B-14)$$

These results and linear scaling for the higher loads are summarized in Table B-3.

TABLE B-3. Predicted Structural Response.

Level	Load, lb	Moment, in-lb	Stress, ksi	Strain, in/inE-6	Deflection, in
Instrument test	1,000	13,900	4.27	-241	0.044
Limit load	4,990	69,200	21.3	-1200	0.220
Yield load	5,740	79,600	24.5	-1380	0.250
Ultimate load	7,480	103,700	31.9	-1800	0.327
Composite yield load	8,960	124,000	38.2	-2160	0.391
Composite ultimate load	11,700	162,000	49.9	-2820	0.510
Predicted failure	14,300	198,000	61.1	-3450	0.623

TEST RESULTS

The test plan is included as Appendix A. It contains the procedures and figures needed to execute the test. The test was performed on 29 February 2000. All fixtures and instrumentation performed as expected. The test was performed in two stages. The first stage was to increase the load to the "composite yield load" and back down to zero. The second stage was to increase the load to failure.

YIELD TEST

Figure B-5 shows the applied load history for this stage of the test. It also includes the 1000-pound instrument check level. The measured strains and displacements for the 1000-pound load were very close to the predicted values, so the test was continued.

The predictions of compressive strain at the forward hanger were made under the assumption that the composite tube was disbanded from the warhead section. Because this test article did not include an intentional release of the warhead section, the strains at the forward hanger (gage 1) will be less than predicted until such a disbond occurs. To verify the predictions, we can look at gage 2, which was placed on the compressive side just aft of the warhead section (2.17 inches aft of the forward hanger) and scale the results up to the increased moment at the forward hanger location. Figure B-6 shows those scaled up results and the predicted values of Table B-3.

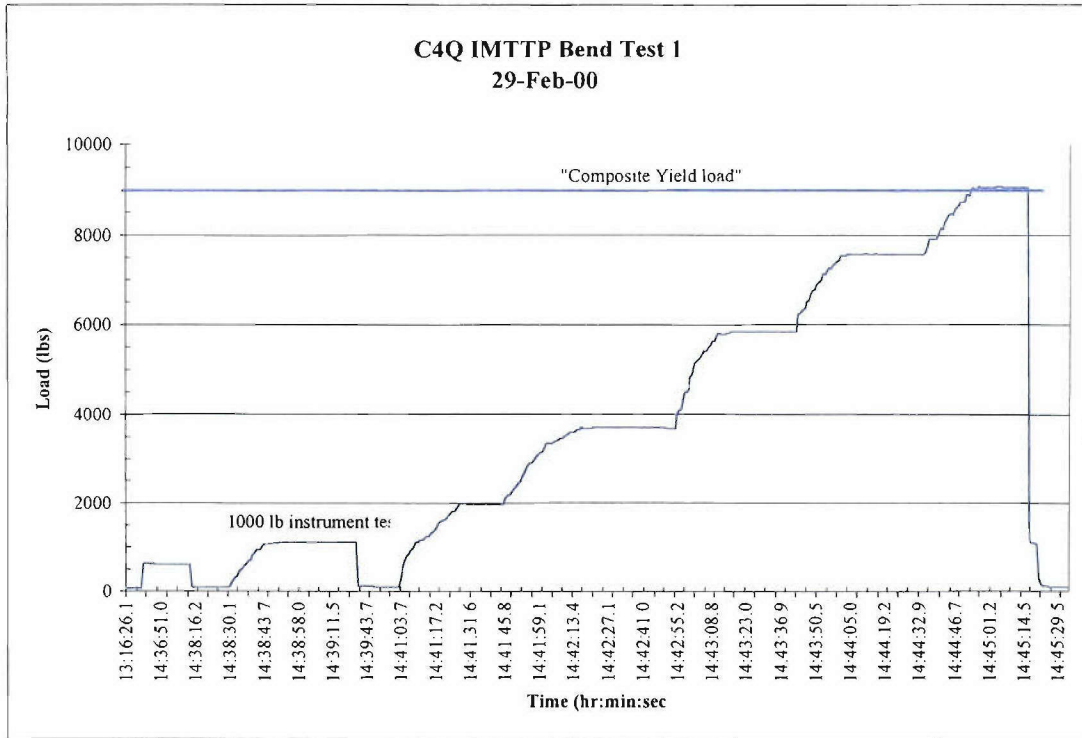

FIGURE B-5. Yield Test Load History.

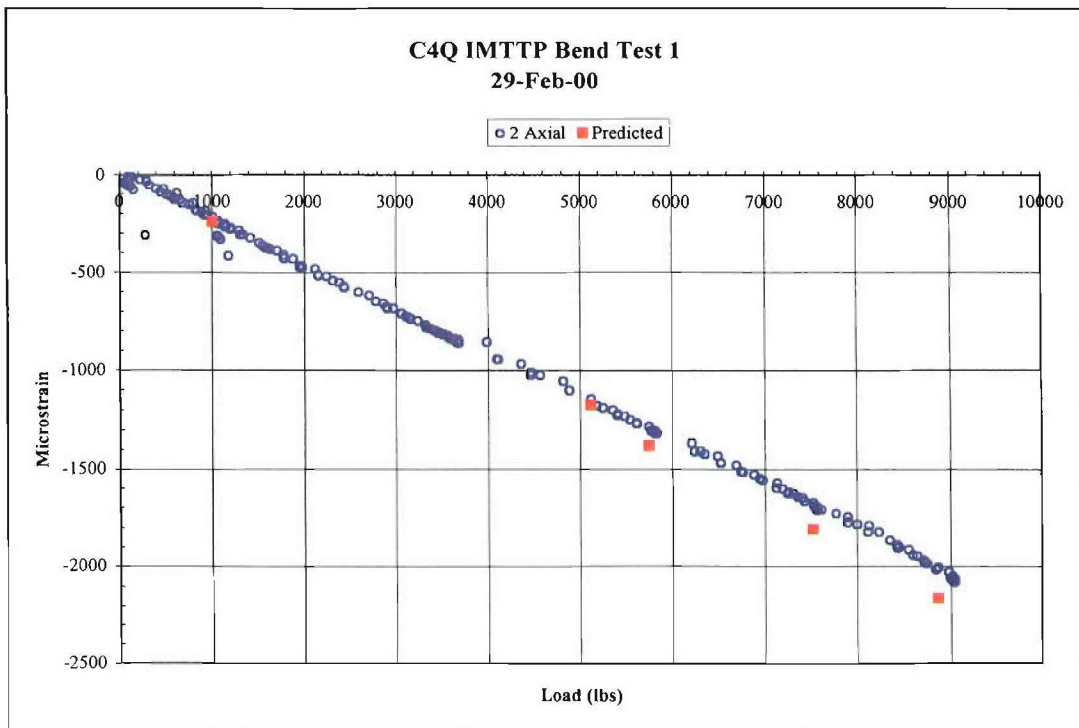

FIGURE B-6. Compressive Strain at Forward Hanger (Estimated From Gage 2).

The return to zero-load strain data are included in above plot. There was no redistribution of strain on any of the gages or discontinuity of strain data. The strain values returned along the same path as the increasing load.

Therefore, the C⁴Q composite tube passed yield test with the loads increased to cover the material knockdowns.

The displacement data are used to verify the EI value used in the analysis. It is also a check of the assumption of the simply supported beam. The data are shown in Figure B-7, along with the predicted values.

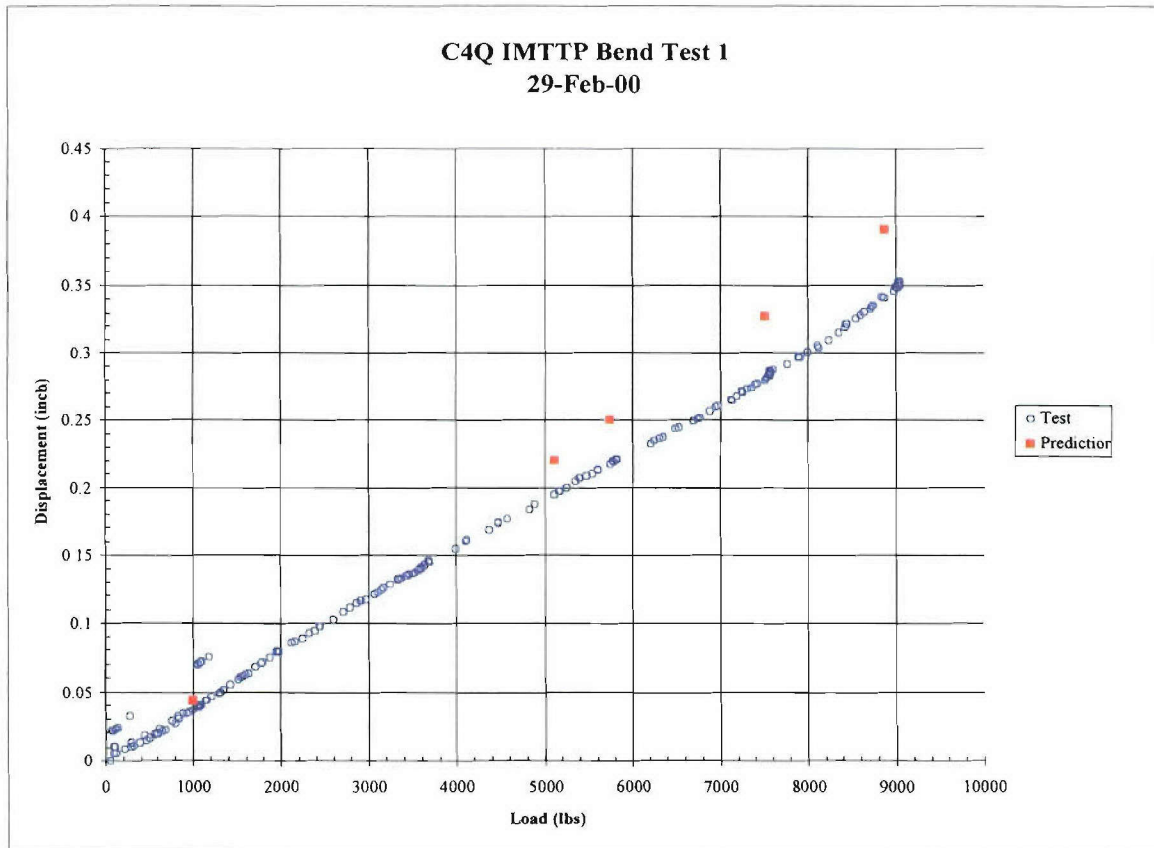

FIGURE B-7. Yield Load Test Displacement.

The displacement data correlate fairly well to the predicted values. The actual displacement is a little less than predicted due, in part, to the contribution of the warhead section (which was omitted in the analysis). This shows that the EI values in the analysis are fairly accurate. It also confirms the assumption that the test clamps are close to producing simply supported three-point bending.

ULTIMATE TEST

The next stage in the test was to increase the load on the tube until failure. The load application history is shown in Figure B-8.

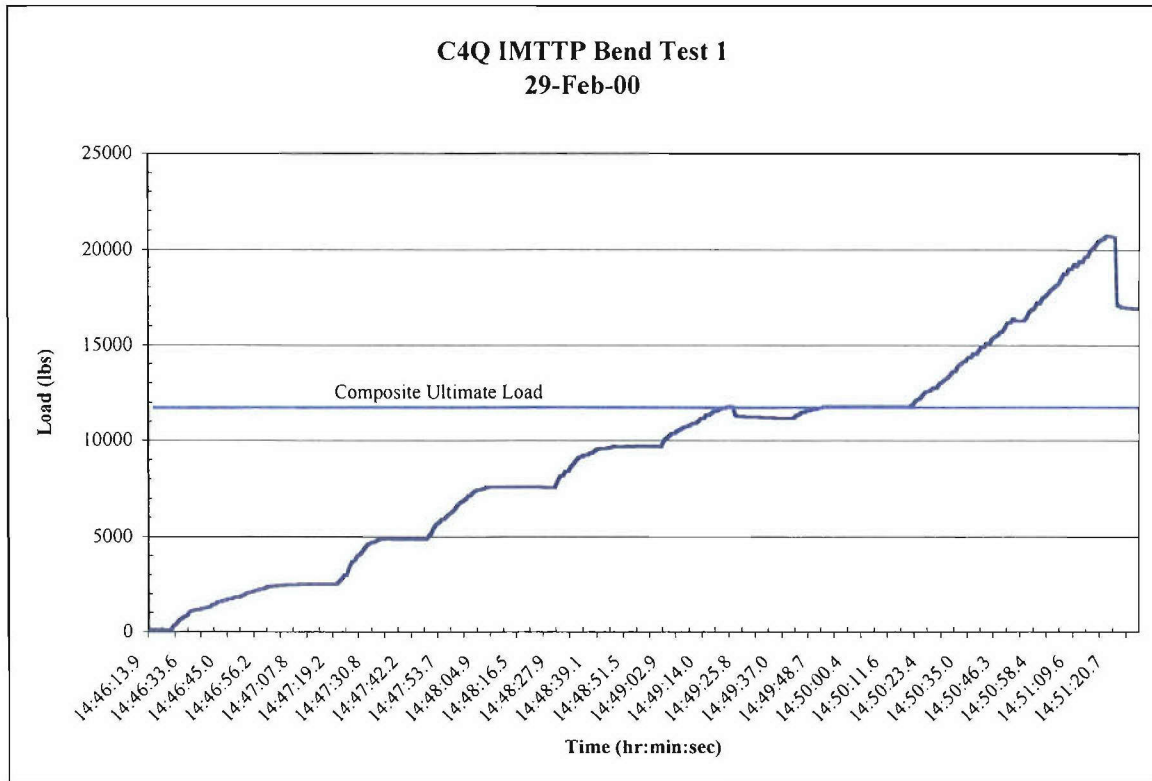

FIGURE B-8. Ultimate Test Load History.

As the load was increased, the first slight popping noise was heard at 11,800 pounds. This load is already higher than the required 11,700-pound ultimate. At this point, there was some redistribution of strains. Most noticeable was that at gage 3 (directly opposite the forward hanger on the "shear side" or neutral axis of the tube). It showed that the composite tube picked up a substantial portion of the shear load from the warhead. Additionally, the displacement increased to align more closely with the predicted value. This indicates that a probable disbond with the warhead section occurred at this point. The increased displacement caused a slight unloading of the tube, creating a dip in the load application curve.

The loading was continued until a second louder popping sound was heard at 16,400 pounds. Again, a redistribution of strain and a slight increase in displacement occurred. Since the tube was continuing to support the load, the load was increased further until a substantial and visible failure occurred at 20,700 pounds. After the failure at 20,700 pounds, the tube was still supporting 16,900 pounds (well past ultimate load); but, due to the clearly visible damage and significant dip in the loading curve, the test was terminated.

Figures B-9 and B-10 provide the ultimate load test displacements and selected strain data, respectively. Figures B-11 and B-12 show gage 2.

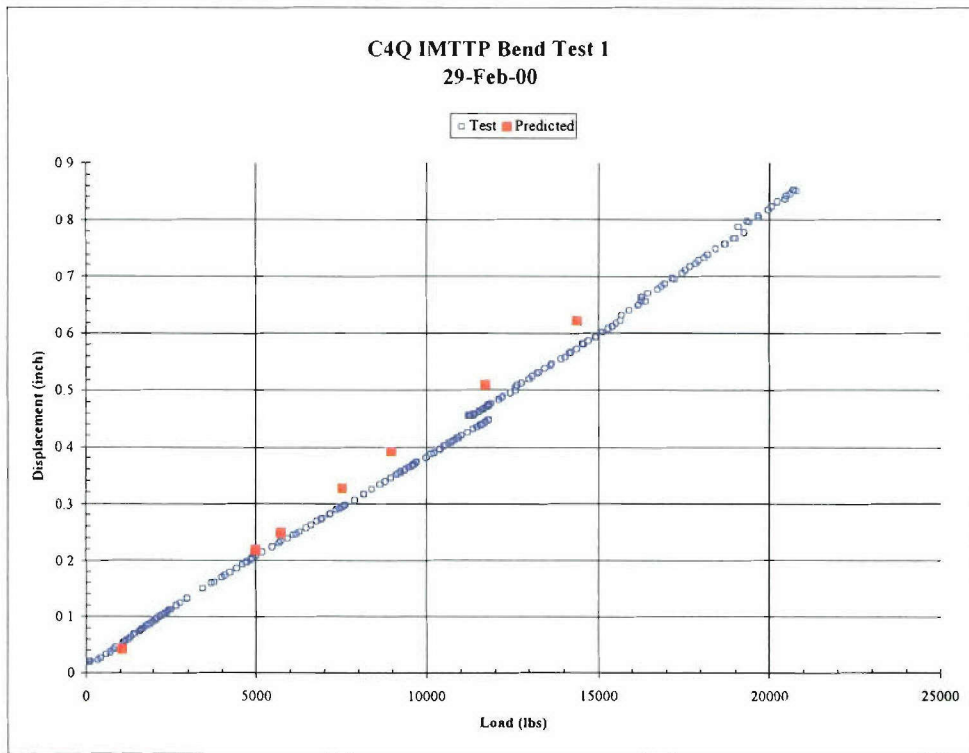

FIGURE B-9. Ultimate Load Test Displacements.

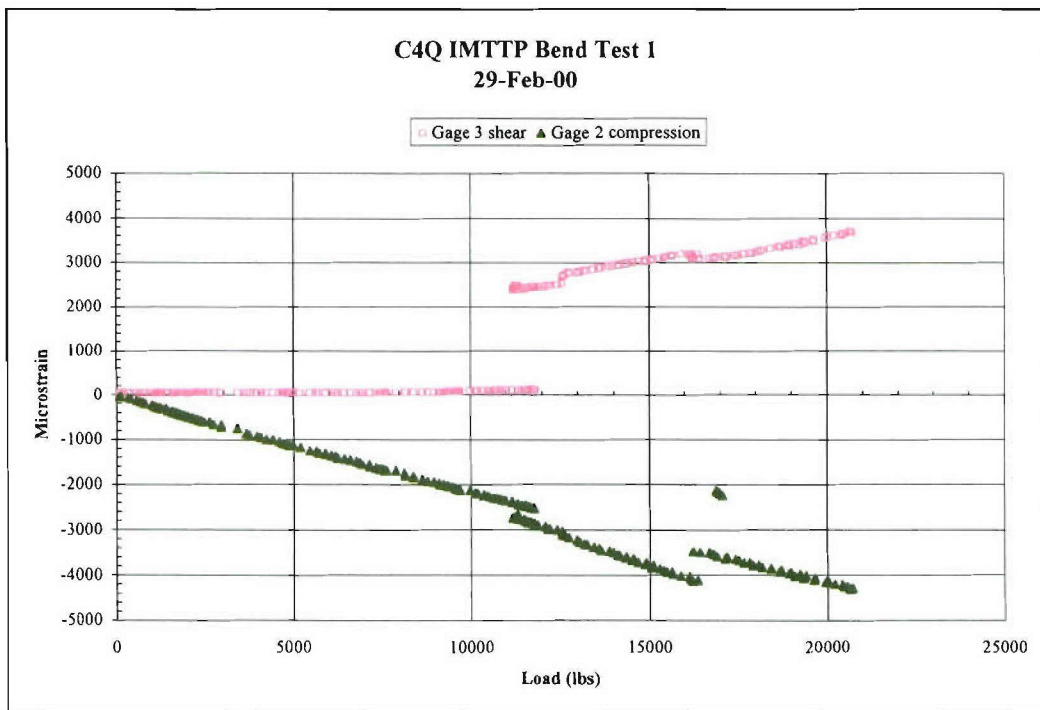

FIGURE B-10. Ultimate Load Test Selected Strain Data.

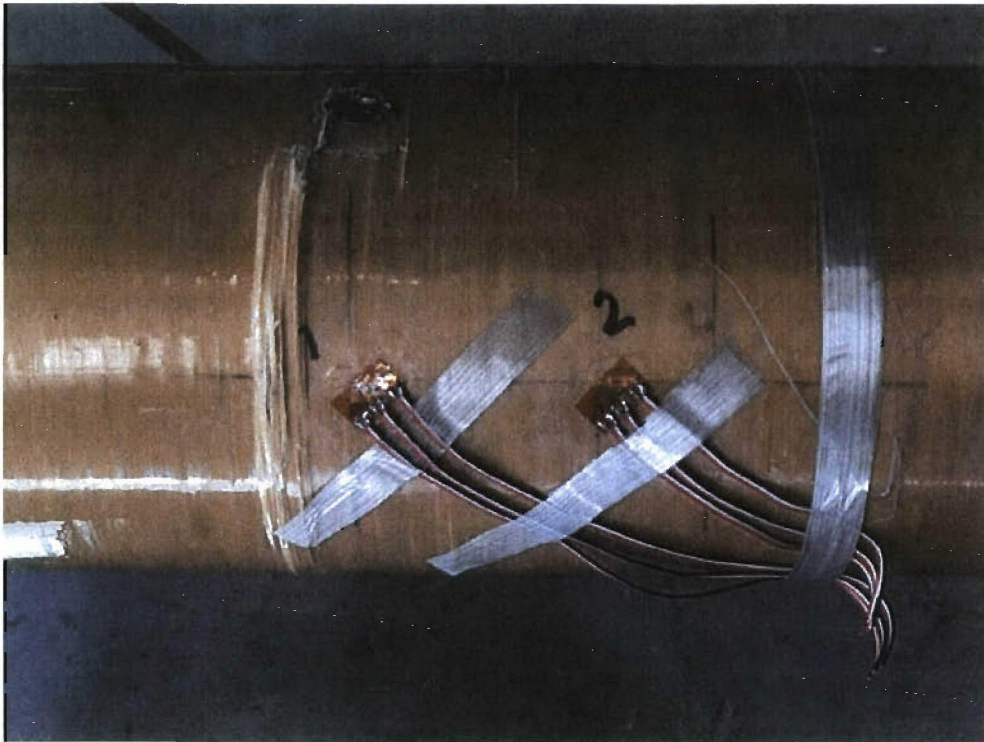

FIGURE B-11. Gage 2 (View 1).

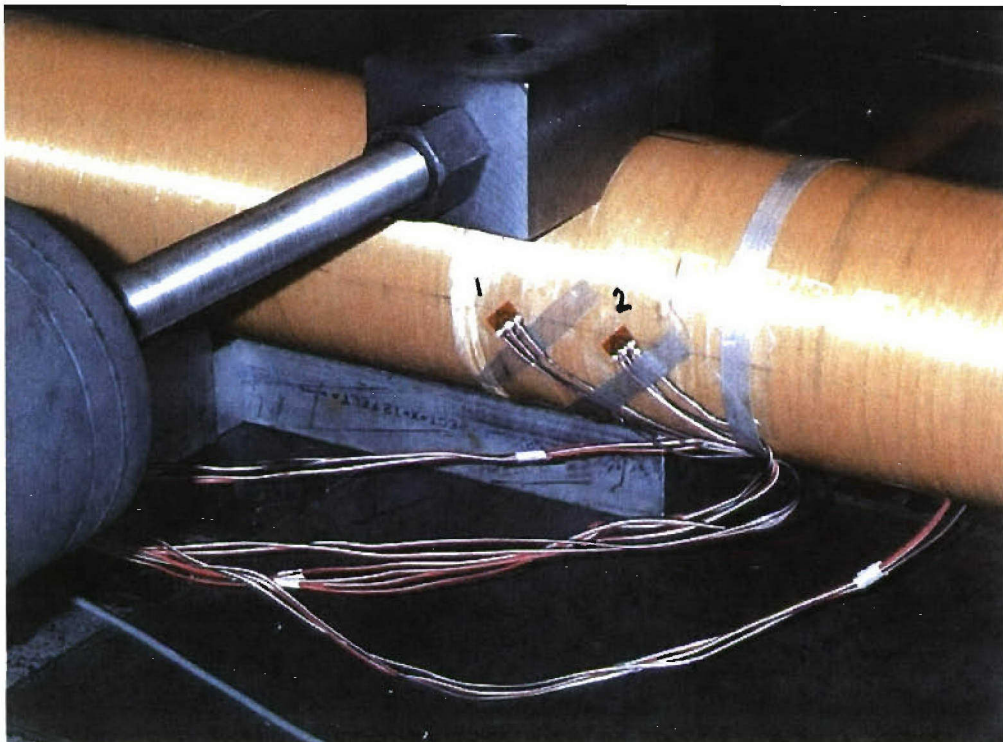

FIGURE B-12. Gage 2 (View 2).

SUMMARY

The test data closely followed the predicted strains and displacements, validating the analysis and test methods. The displacement data suggest that the EI values used are also close; therefore, the first body bending mode frequency predictions will likely be close as well.

The C⁴Q composite blue tube passed the ultimate bending test. The test was performed with the load increased to cover the additional material margins allowed for hot/wet and impact damage. (Later testing will be performed with the specimen preconditioned to hot/wet and damaged conditions.) Based on the increased required load of 11,700 pounds and the failure of the tube at 20,700 pounds, the margin for the undamaged tube is shown in Equation B-15.

$$M.S. = \frac{20700}{11700} - 1 = +0.77 \quad (B-15)$$

In addition to an ample M.S., the failure was not catastrophic and continued to support loads greater than ultimate.

(This page intentionally left blank.)

Appendix C
COMPOSITE CASE CAPTIVE CARRY QUALIFICATION (C⁴Q) BLUE TUBE
TEST PLAN FOR BENDING TEST AFTER TUBE EXPOSED TO
IMPACT DAMAGE AND HOT/WET CONDITIONS

(This page intentionally left blank.)

1.0 INTRODUCTION

This test plan describes the requirements of the Insensitive Munitions Technology Transition Program (IMTTP) Composite Case Captive Carry Qualification (C⁴Q) composite structural verification bending tests after exposure to impact and a hot/wet environment. The composite tube will be first subjected to impact damage, then conditioned in a hot/humid environment. The bending test will then be performed at elevated temperature.

2.0 OBJECTIVE

The primary purpose of this environment and loading test is to verify that design requirements are met. This test plan provides the overall instructions for impacting the IMTTP 5.0-inch composite tube specimen. It contains instructions for subjecting the test item to the humid environment until equilibrium is achieved. And, finally, it contains the instructions for performing the bending test at elevated temperature.

3.0 TEST DESCRIPTION

The test requirements, as defined by the loads given in the design criteria, will be demonstrated via yield and ultimate testing.

Yield testing consists of applying limit loading (69,200 in-lb moment at missile station 44.0 inches) times a 1.15 factor for a total applied bending moment of 79,580 in-lb.

Ultimate testing consists of applying limit loading (69,200 in-lb moment at missile station 44.0 inches) times a 1.5 factor for ultimate testing, resulting in a total applied bending moment of 103,800 in-lb.

The success criteria are as follows. Yield testing shall be considered successful if the case withstands yield moment without anomalous behavior that would be indicative of its inability to perform its intended use. This shall be determined by inspection (visual and dimensional) and comparison of data (strains and deflections) with predicted values.

Ultimate bending moment testing shall be considered successful if the case fails in the predicted manner at 1.5 or higher load factor.

3.1 TEST ARTICLE DESCRIPTION

The test article consists of an IMTTP C⁴Q composite tube (Serial Number 002), as described in drawing number A476200D-126 (C4Q FIRST CURED ASSY) and shown here in Figure C-1. (Note: All of the figures are found at the end of this test plan.) The test article consists of the warhead section and

composite tube only. The composite tube is filled with a urethane/tungsten mix to simulate rocket motor propellant. No wing ribs or hangers are used. The cases are wound by using IM-7 graphite fiber embedded in an epoxy resin. The graphite/epoxy winding lay-up consists of helical (14-degree), axial (0-degree), and hoop (90-degree) layers. A Kevlar overwrap hoop layer is used for protection. A 3/4-inch hole for a pin is added as shown in section B-B of Figure C-1. The holes for the forward hanger are opened up to 1/2-inch clearance holes (see section C-C of Figure C-1).

3.2 TEST FACILITIES

The test facility is located at the Code 476300D environmental laboratory. Bending moment tests will be done on the static frame tester, while the hot/wet environment conditioning will be done in the large (Sexton) temperature chamber.

The test equipment for the bending moment test consists of a hydraulic load jack, load cell, strain gages, a displacement transducer, and signal conditioning and recording equipment. The test equipment for the hot/wet environment conditioning consists of the large temperature chamber, flexible heater with controller, and thermocouples. The equipment for the impact test consists of the Code 476J00D impact tester modified for full-length tube testing.

The test fixturing to be used for the bending test will include two tie-down collars (one with a 0.75-inch pin at 12 o'clock) and a forward hanger replacement block. The layout of the test fixtures is shown in Figure C-2.

4.0 INSTRUMENTATION AND DATA REQUIREMENTS

The instrumentation requirements for these tests will be the same for both proof (yield) and ultimate tests. All strain gages are 45-degree rectangular rosette (MM CEA-06-125 UR-350) gages. The placement of the instrumentation is shown in Figure C-3.

The accuracy requirements for the instrumentation through the data recording system shall be as shown in Table C-1.

TABLE C-1. Accuracy Requirements.

Strain Gages	±0.08% strain
Load Cell	±10.0 lb
Displacement Potentiometers	±0.01 inch
Thermocouples	± 5°F

The test data shall be reduced and plotted at five samples per second. Two copies of all printouts and plots are required. The digital listings (printouts) will have the strain and displacement as a function of load. Digital plotting will be in the format described in Table C-2.

TABLE C-2. Digital Plotting Format.

Instrumentation	Abscissa	Ordinate
Load (shear load) cell	Time, seconds	0 to 20,000 lb
Strain gages (SG1-SG12)	0 to 20,000 lb	-3.50 to 3.50%
Displacement potentiometer (DPI)	0 to 20,000 lb	0 to 0.70 inch
Thermocouples	Time, minutes	0 to 300°F

5.0 TEST PROCEDURE AND SETUP

5.1 IMPACT OF TEST ARTICLE

This test will utilize the Code 476J00D impact tester modified to accommodate a full-length composite tube with inert fill. The impact tester has a 12.5-pound slider and a 1/2-inch-diameter spherical tup. The release height for the slider is 19.2 inches (producing a 20-foot-pound impact). The test article will be struck on the compression side (20.5 inches aft of the front face of the warhead) and farther aft in the unsupported part of the composite tube (20.5 inches aft of the front face of the warhead). The locations are shown in Figure C-4.

5.2 HOT/WET ENVIRONMENT CONDITIONING OF TEST ARTICLE

Composite materials when exposed to high humidity for prolonged periods absorb moisture, which adversely affects the mechanical properties. High temperatures also have a negative effect. Consequently, this test will condition the composite test sample in a chamber at 85% relative humidity and 130°F for several weeks until moisture equilibrium is achieved. The sample will then be heated to 215°F for a minimum of 6 minutes (worst F-18C/D wing tip aero-heat temperature) and subjected to the bending moment tests to assess the effect of moisture absorption and elevated temperature.

The general moisture conditioning procedure is as follows.

1. Weigh tube to determine the as-received weight.
2. Place tube in temperature/humidity chamber and initiate test conditions of 85% relative humidity at 130°F. Maintain chart data for chamber conditions.
3. Remove the tube every 1 to 4 days of conditioning and weigh. Once per day is preferred, but weekend weights can be omitted.
4. Return item immediately to chamber and resume test conditions.
5. Determine if moisture equilibrium has been reasonably approached. If not, continue conditioning. Otherwise proceed to bending moment tests.
6. Once equilibrium has been reached, then determine the weight lost over a 3-hour period in room temperature conditions, then return the specimen to re-attain equilibrium. (This is to verify the specimen is still sufficiently conditioned throughout the testing time.)

5.3 BENDING MOMENT TESTS

The types of gages are noted in Figure C-3. These gages must be protected. Thermal compensation is required as the flexible heater encasing the tube will be maintaining a temperature of 215°F. Prior to the tests, the test director will define selected priority data, which will be immediately processed and reviewed prior to proceeding with the testing. Maintaining the moisture content from the preconditioning is important. The test should be set up and performed in as short a period of time as possible (definitely on the same day).

The general test procedures are as follows.

1. Remove test article from the moisture chamber.
2. Attach the load actuator stinger to the forward hanger replacement block.
3. Place all assembly into the static test frame and assemble composite tube to the forward hanger replacement block.
4. Attach the aft collar tie assembly to the aft section of the composite tube.
5. Align the forward collar and insert the pin through the collar and tube.
6. Fit position displacement potentiometer according to Figure C-2.
7. Connect all instrumentation.
8. Cover composite tube with flexible heater and stabilize test item at 215°F (+10/-0).
9. Take pretest photographs of the test setup.
10. Slowly raise the load to 1000 pounds and then lower the load back to zero. Observe strain gage and displacement readings. Verify all instrumentation is operating properly.
11. Once correct instrumentation operation has been confirmed, start recording data and begin to raise the load in accordance with Figure C-4. Note the steps in the loading to allow for instrument stabilization.
12. Turn off instrumentation and disconnect all lead wiring and fixtures.
13. Note all anomalies during and after the testing.
14. Take post-test photographs of the test setup.
14. Remove test article (see Sections 5.3.1 and 5.3.2).

5.3.1 Test Precautions

The composite tube will be placed in an isolated area during the test. Hazardous flying debris is expected during the ultimate test and all precautions shall be taken to avoid exposure to the debris. Extreme care should be taken in handling the remains of the case after the test is completed. All the bending moment tests must comply with all Code 476300D safety requirements.

5.3.2 Test Article Disposition

The composite tube with inert fill will be post inspected after proof (yield) and ultimate tests by Code 476J00D personnel. The tube will be delivered to Code 476J00D for sectioning into coupons and cylindrical test articles after the ultimate test.

6.0 SUMMARY

Following this bending moment test, a summarized report shall be drafted describing the test and the results. Pertinent diagrams and graphs shall be included.

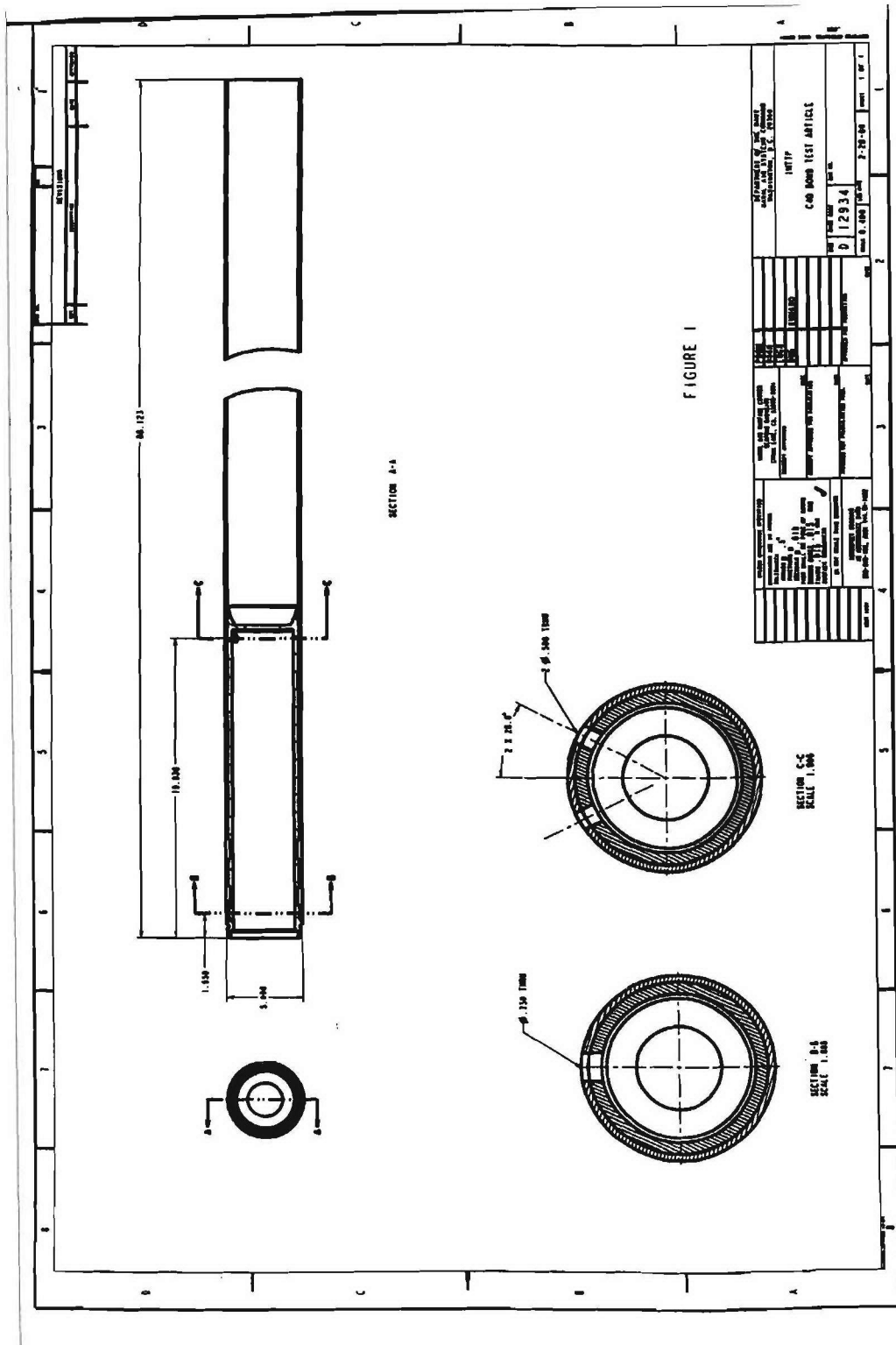

FIGURE C-1. Drawing Number A476200D-126 (C⁴Q FIRST CURED ASSY).

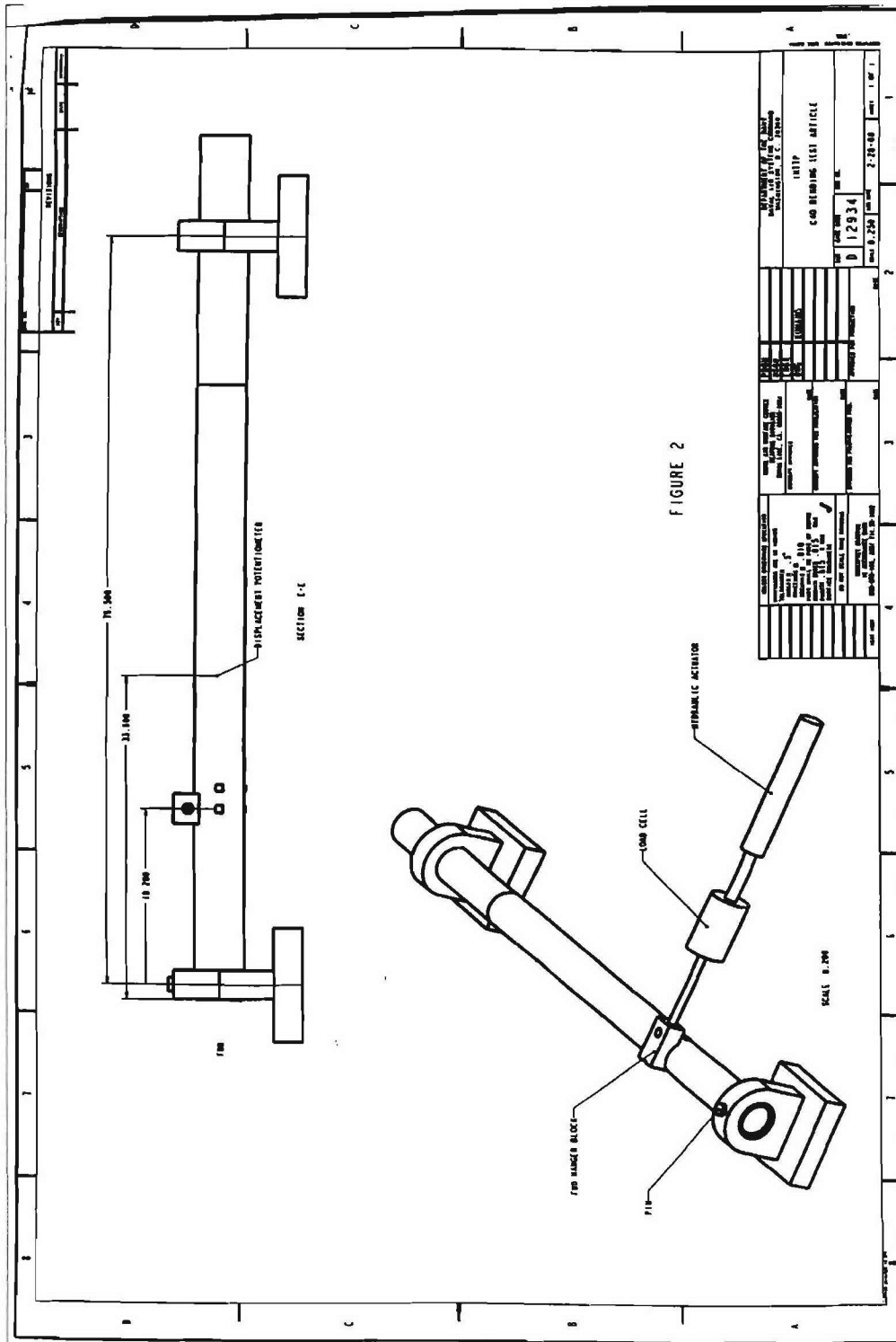

FIGURE C-2. Layout of Text Fixtures.

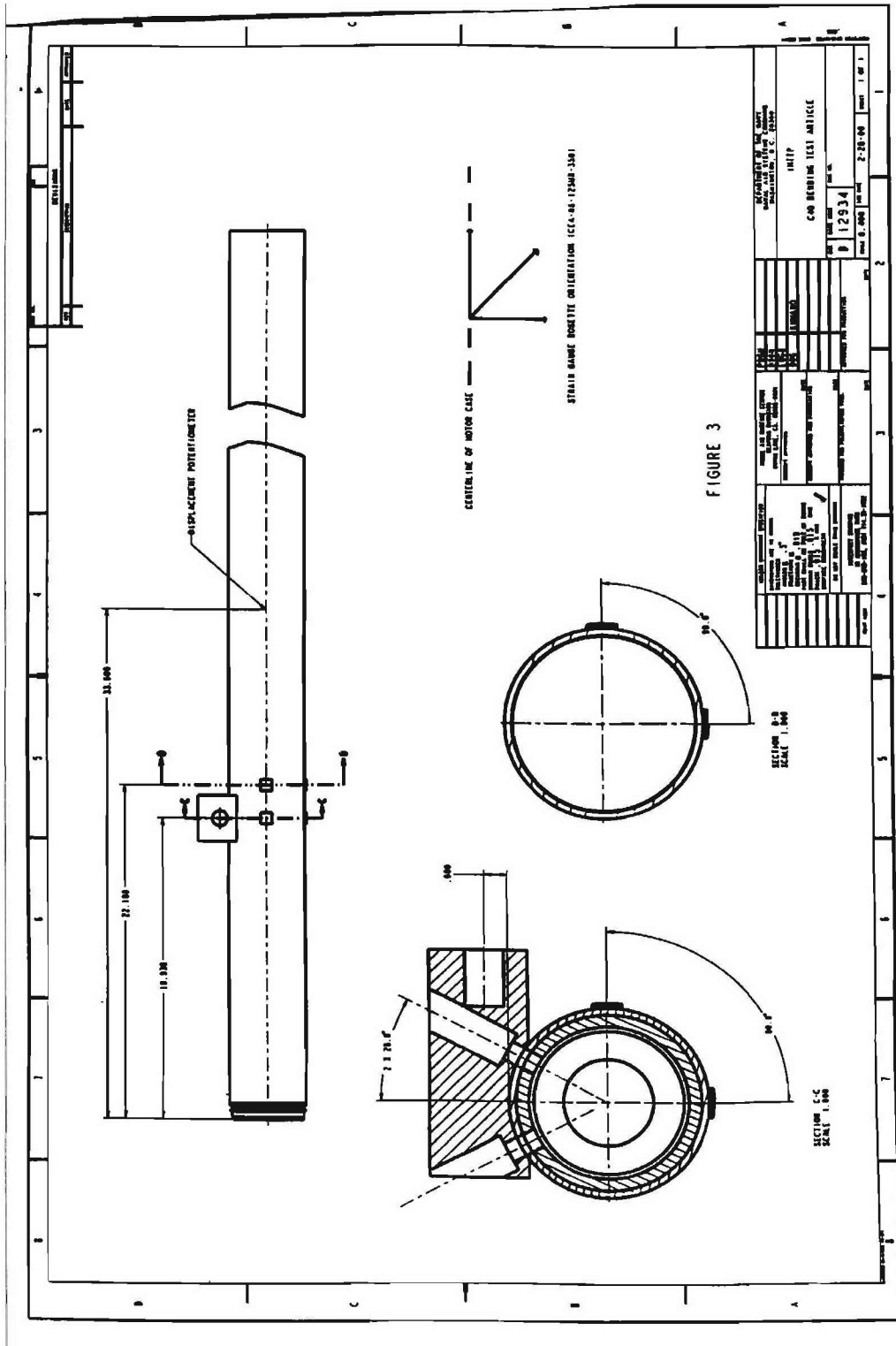
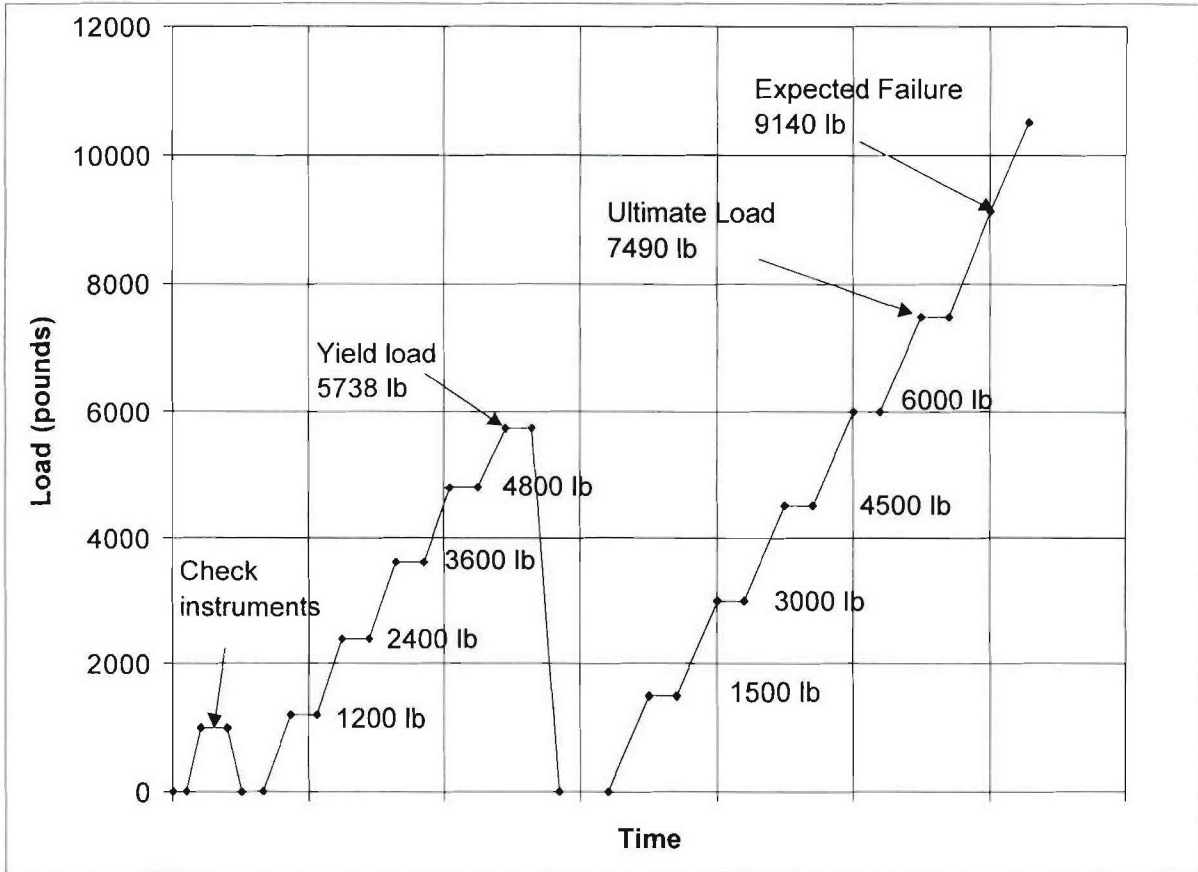

FIGURE C-3. Instrumentation Placement.



	Applied Load, lb	Resulting Moment, in-lb	Strain, inches/inch	Maximum Displacement, inches
Instrument test	1,000	13,870	0.000241	0.044
Yield load	5,738	79,586	0.001383	0.250
Ultimate load	7,490	103,886	0.001805	0.327
Predicted failure	9,140	126,600	0.002200	0.402

FIGURE C-4. Load Schedule.

(This page intentionally left blank.)

Appendix D
COMPOSITE CASE CAPTIVE CARRY QUALIFICATION (C⁴Q) BLUE TUBE
TEST REPORT FOR BENDING TEST AFTER TUBE EXPOSED TO
IMPACT DAMAGE AND HOT/WET CONDITIONS

(This page intentionally left blank.)

CONTENTS

Test Description	D-5
Introduction.....	D-5
Test Specimen.....	D-5
Specimen Impact Damage.....	D-5
Specimen Moisture Conditioning	D-8
Elevated Temperature Conditioning	D-8
Loading Condition.....	D-8
Analysis of Loading	D-10
Three-point Bending.....	D-10
Test Results	D-11
Yield Test.....	D-11
Ultimate Test.....	D-11
Summary.....	D-15

Figures:

D-1. All-up-round (AUR) Structural Layout.....	D-5
D-2. Impact Tester.....	D-6
D-3. Impact Damage Locations	D-6
D-4. Forward Impact Damage Location	D-7
D-5. Aft Impact Damage Location.....	D-7
D-6. Test Article and Coupon Weight Gain	D-8
D-7. Test Setup (View 1).....	D-9
D-8. Test Setup (View 2).....	D-9
D-9. Bending Test Moment Diagram	D-10
D-10. Yield Test Strain History	D-12
D-11. Ultimate Test Load History.....	D-12
D-12. Ultimate Load Test Selected Strain Data	D-13
D-13. Temperature Data During Ultimate Test.....	D-13
D-14. Failure Photograph 1	D-14
D-15. Failure Photograph 2	D-14

(This page intentionally left blank.)

TEST DESCRIPTION

INTRODUCTION

The Composite Case Captive Carry Qualification (C⁴Q) blue tube bending test exposed to impact damage and hot/wet conditions is a full-scale structural test of the composite blue tube in bending. The goal was to simulate the worst-case bending load on the missile body. This test, in combination with other testing, is intended to demonstrate the structural adequacy of the C⁴Q blue tube design. This test is performed on a full-scale specimen with an applied temperature of 215°F after moisture conditioning in 85% humidity. Impact damage was inflicted on the tube in two locations prior to moisture conditioning. The test showed an ultimate margin of safety (M.S) for bending of the damaged tube of +0.08. This was with a 1.5 factor of safety for ultimate.

TEST SPECIMEN

For reference, Figure D-1 shows the basic structural layout of the CATM-9M with the C⁴Q hardware. The test article omits the guidance and control section (GCS), wings, fins, and hangers. None of these items were considered necessary for this test. The forward hanger bolt holes were enlarged and a locating pin hole added per the instructions in the test plan. This allowed sufficient load to be applied to the composite case for it to fail in the composite section without failing at the forward hanger or spinning in the fixture.

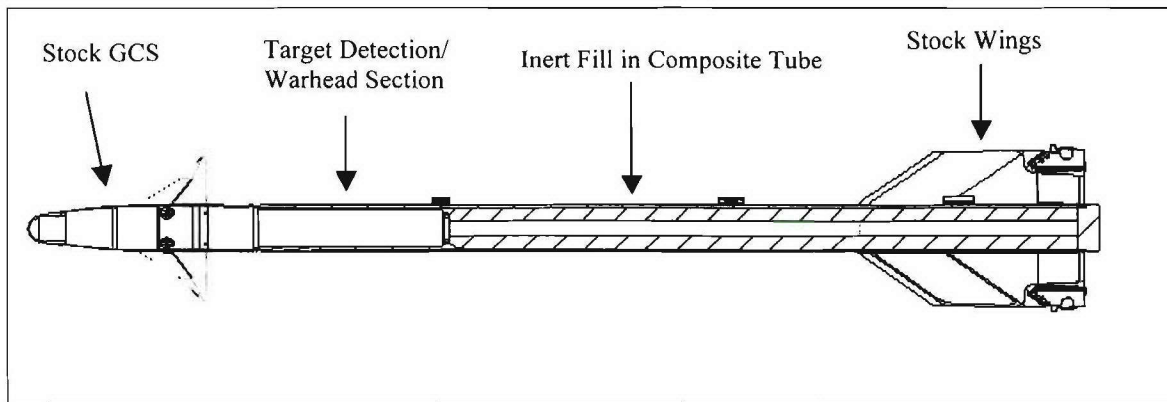

FIGURE D-1. All-up-round (AUR) Structural Layout.

SPECIMEN IMPACT DAMAGE

The test specimen was subjected to impact damage in two locations. The first location was at the maximum bending moment (i.e., the front hanger). Because the first location is supported internally by the metal warhead section, a second impact location was chosen 2.5 inches aft of the warhead section to produce damage in an "unsupported" area. Both impact points were on the compression side of the tube in bending. The impact was made with a 1/2-inch-diameter tup with 18.75 foot pounds of energy. The

impact fixture is shown in Figure D-2. This produced impact damage that is clearly visible to the naked eye from 5 feet away. Figures D-3, D-4, and D-5 show the damaged areas.

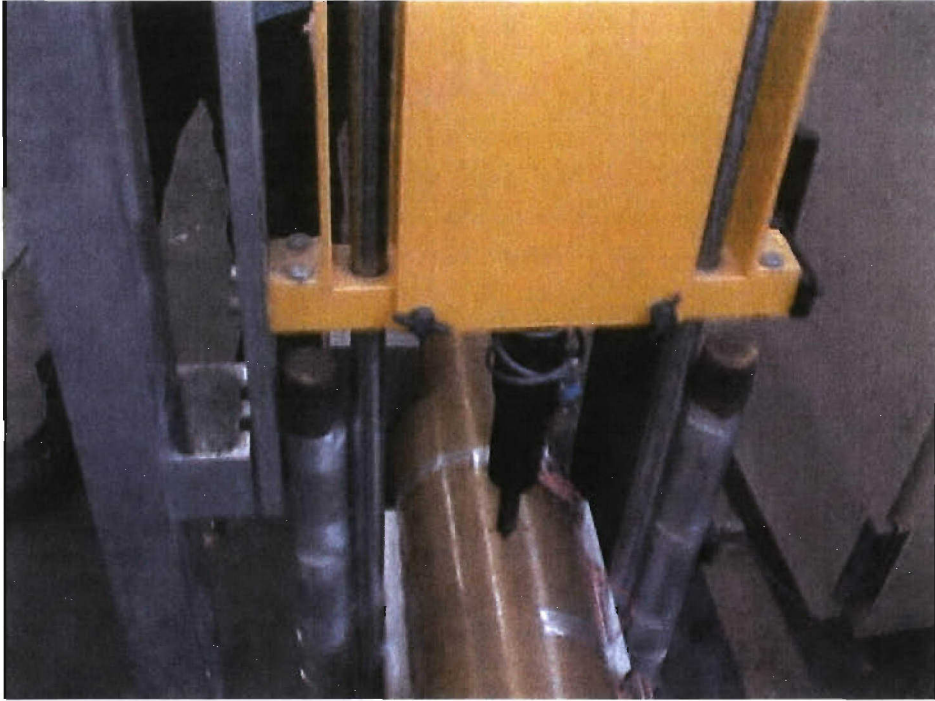

FIGURE D-2. Impact Tester.

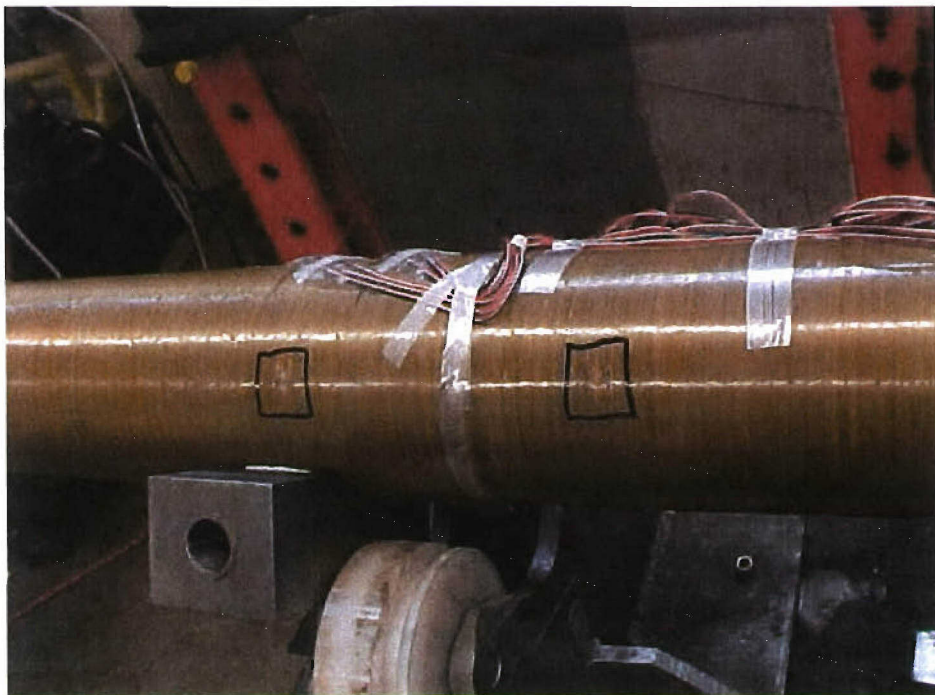

FIGURE D-3. Impact Damage Locations.

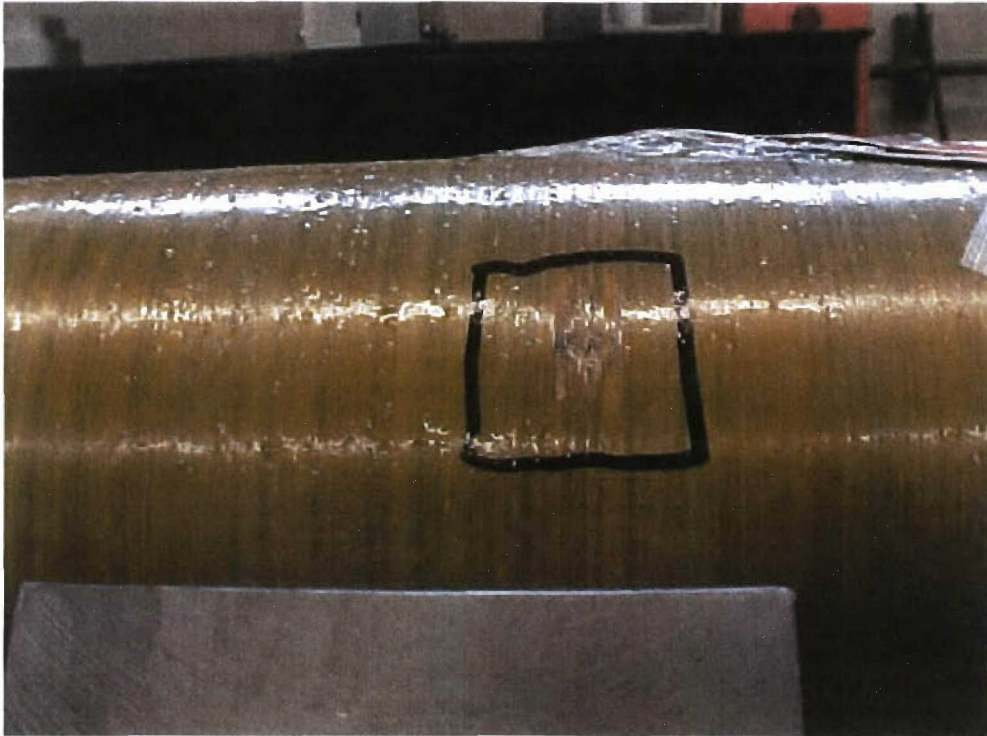

FIGURE D-4. Forward Impact Damage Location.

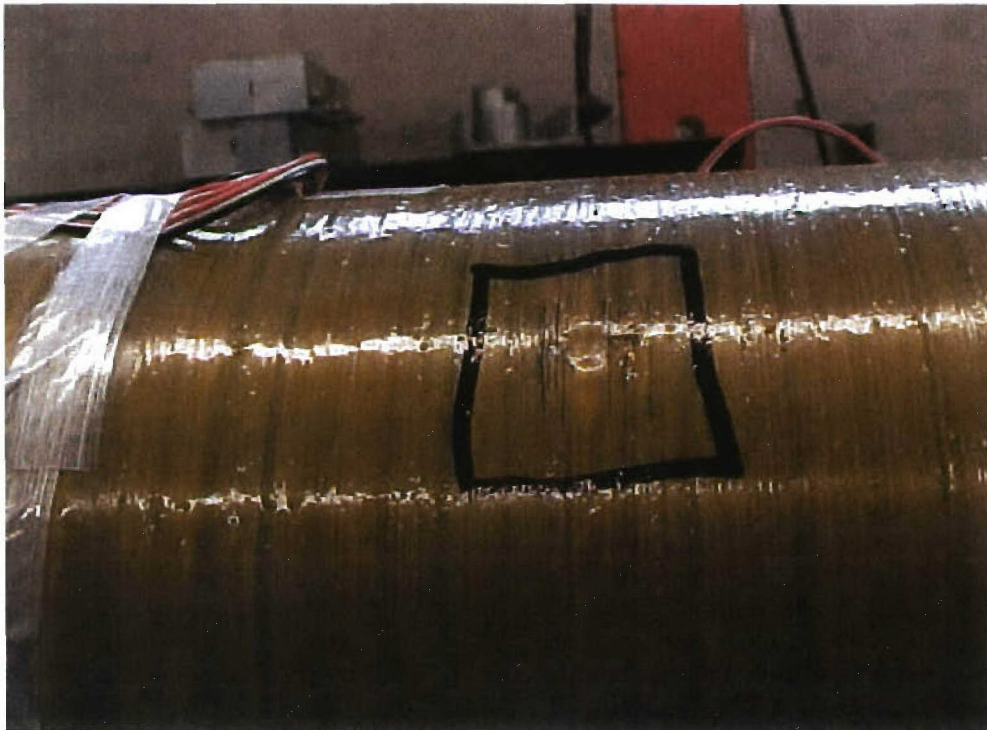

FIGURE D-5. Aft Impact Damage Location.

SPECIMEN MOISTURE CONDITIONING

The test specimen was subjected to 85% humidity at 130°F for 33 days. The weight equilibrium changes were difficult to measure on the full-scale test article due to the extra weight of the metal components and inert fill. Therefore, a small coupon was included in the chamber to track the weight gain due to moisture absorption. The weight gain is charted here in Figure D-6.

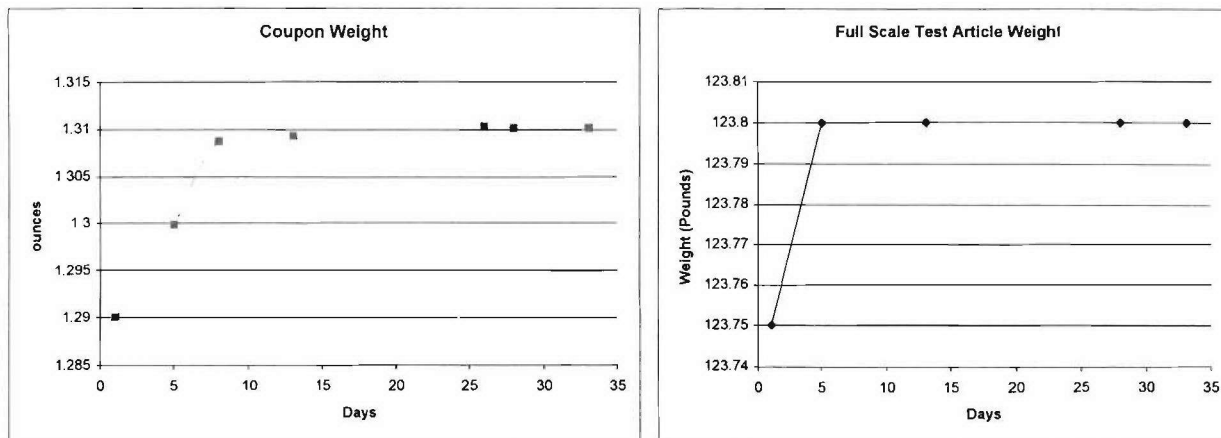

FIGURE D-6. Test Article and Coupon Weight Gain.

ELEVATED TEMPERATURE CONDITIONING

The specimen was tested at elevated temperature. The original design specification used 248°F as the highest temperature during captive carriage. This was based on worst-case stagnation temperature at the wing tip on the F/A-18C/D. Since that time, better environmental information has become available. NAWCWPNS TP 8359 Volume 1 states the wing tip maximum service temperature as 165°F (for a maximum of 6 minutes). Adding 50°F to provide a material operating limit cushion indicates that a 215°F test temperature will cover the extreme wing tip temperature condition.

To achieve this elevated temperature, the specimen was covered with heating blankets and insulation. The temperature was controlled electronically to maintain 215°F. Although this temperature is present for only 6 minutes, the specimen was soaked for about 30 minutes. This was due to the test setup time rather than any effort to reach a thermal equilibrium.

LOADING CONDITION

The specimen was loaded in a three-point bending fixture. The locations of the end clamping fixtures and load application point were designed to approximate the moment diagram during the worst-case bending maneuver (the Mk 84 bomb release). A block-like replacement for the forward hanger was used to simulate the load transfer through the forward hanger. This reduced the risk of forward hanger failure to prevent an invalid test and wasted specimen. The loading was raised to yield level and returned to zero in order to confirm that no permanent deformation occurred. The loading was then raised until it produced failure. The fixtures and loading sequence can be seen in detail in the test plan (Appendix C) and in Figures D-7 and D-8. Notice the heating blankets and insulation to produce the elevated temperature for the test.

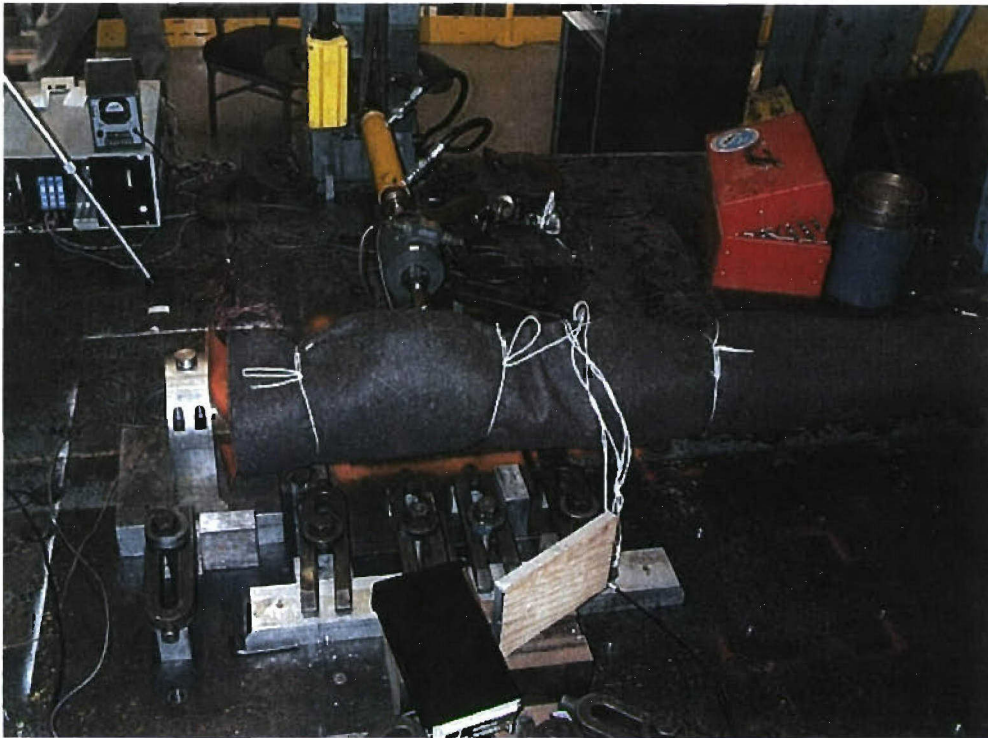

FIGURE D-7. Test Setup (View 1).

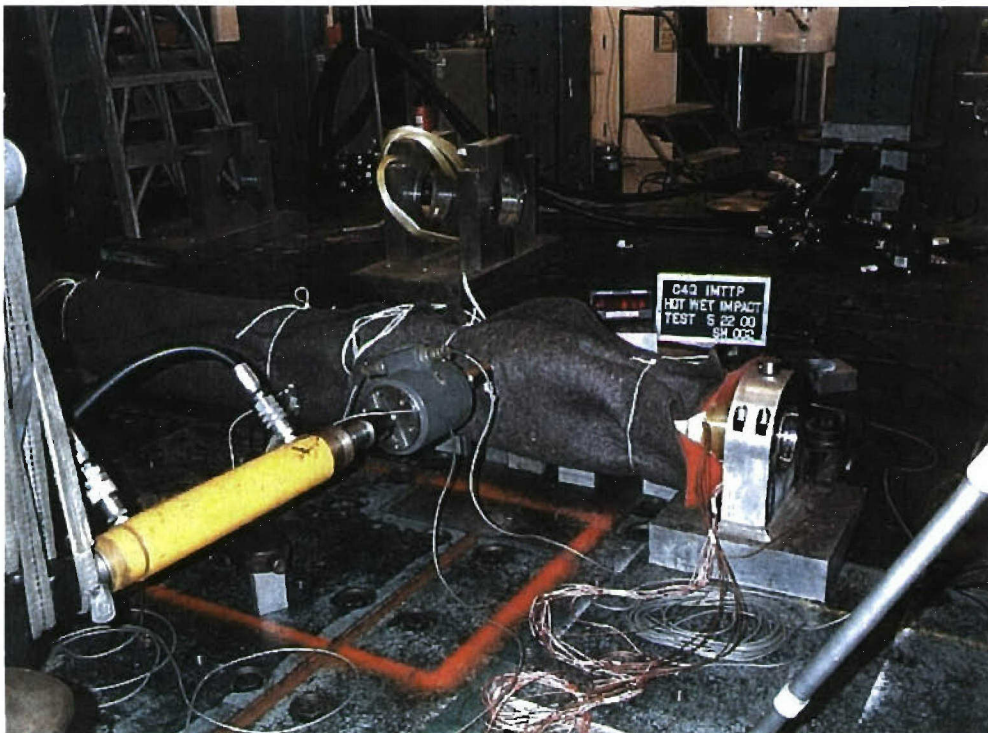

FIGURE D-8. Test Setup (View 2).

ANALYSIS OF LOADING

THREE-POINT BENDING

The development of the three-point bending fixture and loading values is based on the assumption that the composite tube will fail at or near the forward hanger where the bending moment is most severe. The assumption of simple supports is used due to the geometry of the clamps and the clearance with the tube. The clamp locations were estimated by fitting a triangular moment diagram (typical for three-point bending) onto the maximum moment envelope. The peak at the forward hanger is for the Mk 84 release condition (worst-case limit load). Figure D-9 shows the results. Note that the locations of the base corners of the triangle correspond to the clamping locations. This test uses the same fixtures as the bending test of C⁴Q tube Serial Number 001 (room temperature, dry bending test).

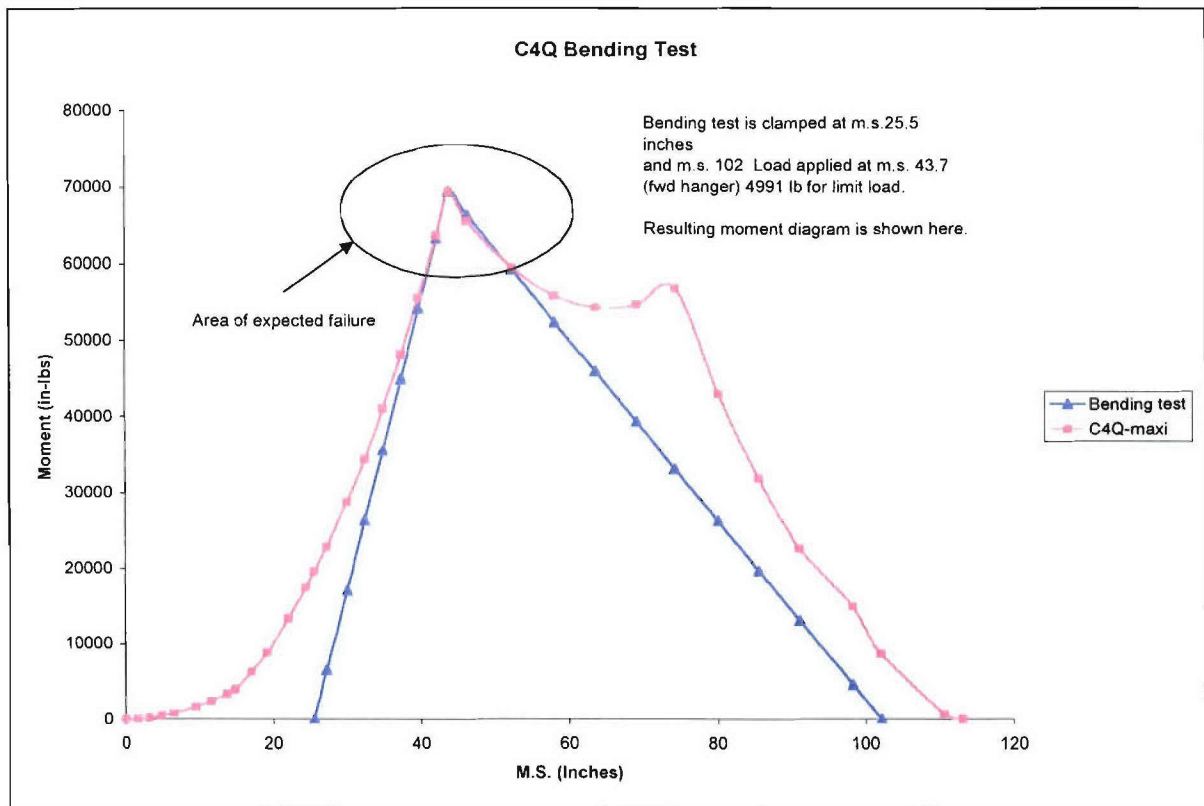

FIGURE D-9. Bending Test Moment Diagram.

The magnitude of the needed applied load was determined by working backward from the triangular moment diagram.

The shear in front of the load is equal to moment divided by the distance from front clamp to load ($[69,200 \text{ in-lb}]/[18.2 \text{ inches}] = 3800 \text{ pounds}$). The shear behind the load is equal to negative moment divided by the distance from load to the back clamp ($-[69,200 \text{ in-lb}]/[58.3 \text{ inches}] = -1190 \text{ pounds}$). The

total applied load is 4990 pounds (3800 pounds + 1190 pounds). This value is for the AIM-9M limit load condition. Therefore, Equations D-1 and D-2 apply.

$$\text{Yield Load} = 4990 \times 1.15 = 5738 \text{ pounds} \quad (\text{D-1})$$

$$\text{Ultimate Load} = 4990 \times 1.50 = 7485 \text{ pounds} \quad (\text{D-2})$$

TEST RESULTS

The test plan is included as Appendix C. It contains the procedures and figures needed to execute the test. The test was performed on 22 May 2000. All fixtures and instrumentation performed as expected. The test was performed in two stages. The first stage was to increase the load to the yield and back down to zero. The second stage was to increase the load to failure.

YIELD TEST

Figure D-10 shows the axial compressive strain in the tube at the edge of the warhead section. The initial strain values at zero load are due to the application of heat after the instrumentation was set to zero strain.

The results show that the tube returns to zero load without any residual strain or load redistribution. There was no redistribution of strain on any of the other gages or discontinuity of strain data. The strain values returned along the same path as the increasing load.

Therefore, the C⁴Q composite tube passed yield test at maximum temperature and moisture content with visible levels of impact damage.

ULTIMATE TEST

The next stage in the test was to increase the load on the tube until failure. The load application history is shown in Figure D-11.

As the load was increased, there were no cracking or popping sounds until failure at the maximum load of 8109 pounds.

The compressive axial strain at the edge of the warhead section is presented in Figure D-12. Again, note the zero offset due to the elevated temperature. The thermocouple readings are shown in Figure D-13. They establish that thermal equilibrium was reached. Note that the control gage was on the surface of the composite tube away from the metal underlying structure of the warhead. As a control, this most closely represented the "applied external temperature" of the environment. The location of thermocouple (TC 6) is at the forward hanger at 9 o'clock (looking aft with hanger at 12 o'clock). The control thermocouple (TC 7) is near the aft impact point at 12 o'clock. Thermocouple (TC 8) is 20 inches aft of the forward hanger at 10 o'clock. Figures D-14 and D-15 are photographs of the failure.

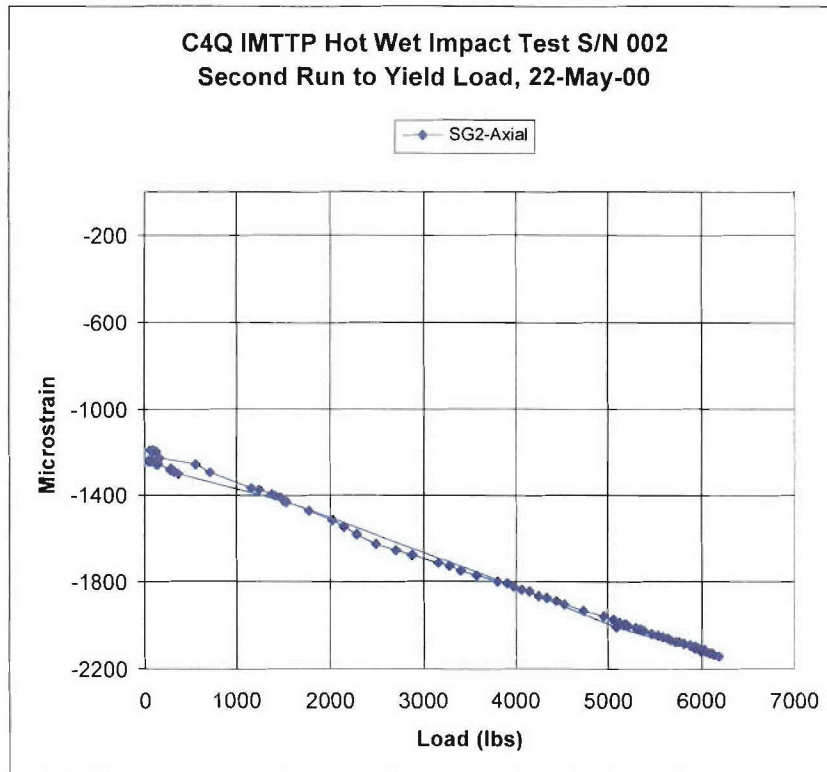

FIGURE D-10. Yield Test Strain History.

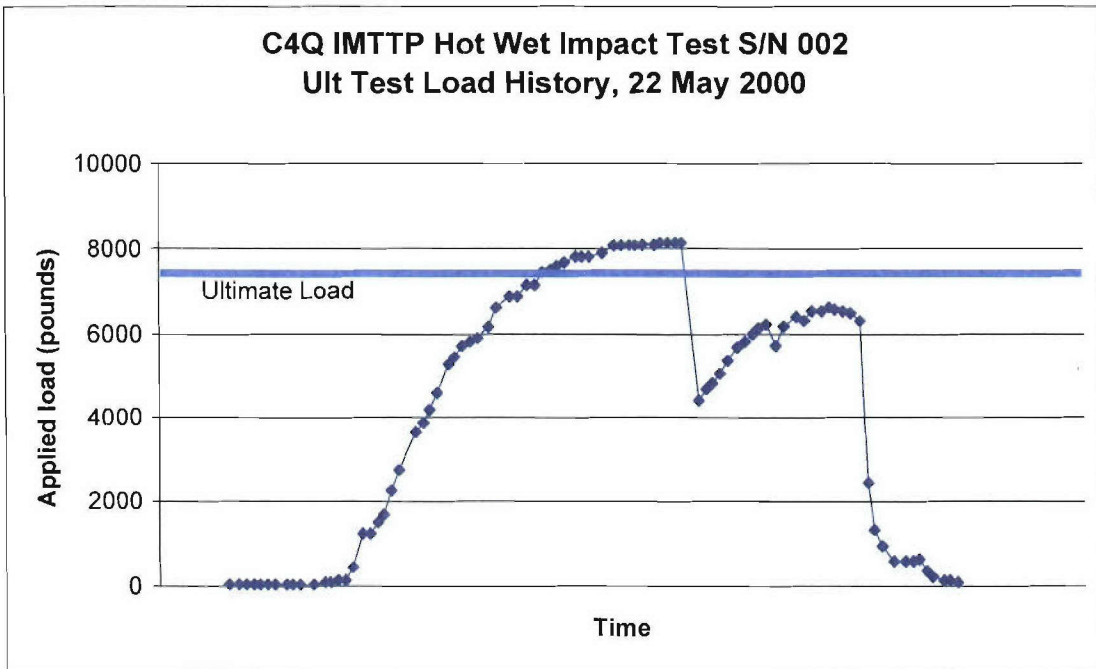

FIGURE D-11. Ultimate Test Load History.

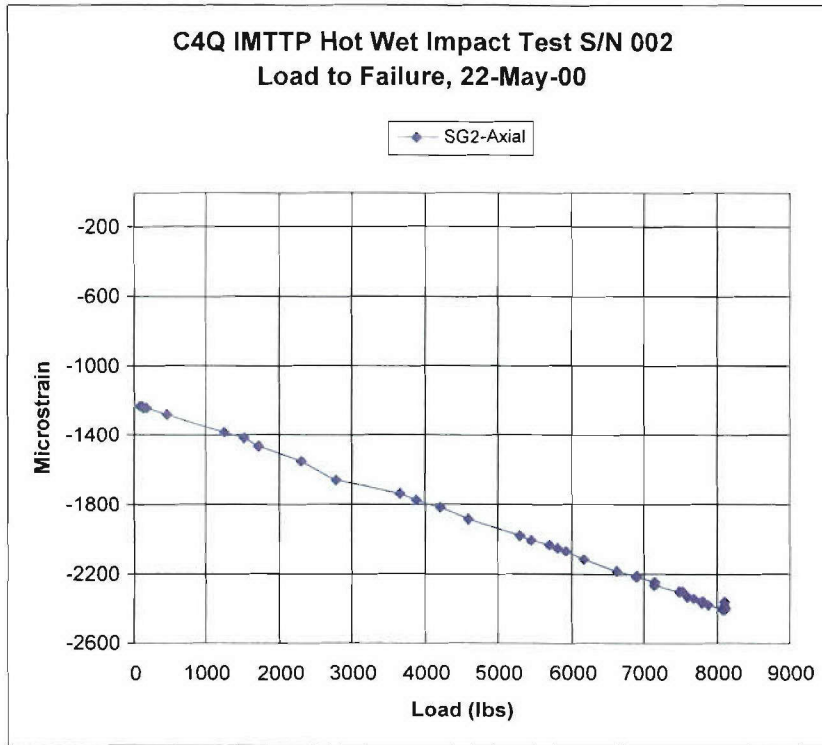

FIGURE D-12. Ultimate Load Test Selected Strain Data.

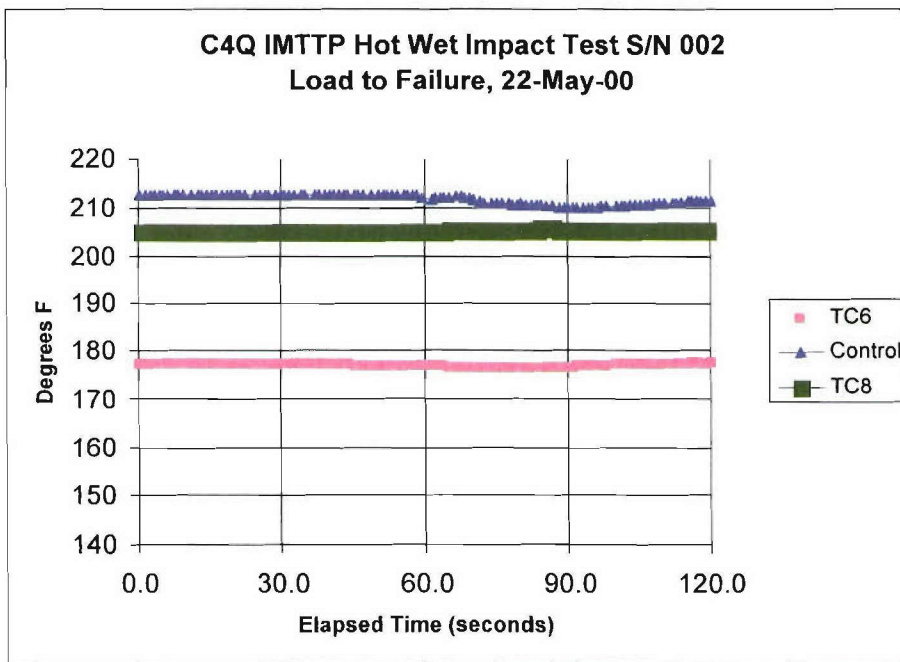

FIGURE D-13. Temperature Data During Ultimate Test.

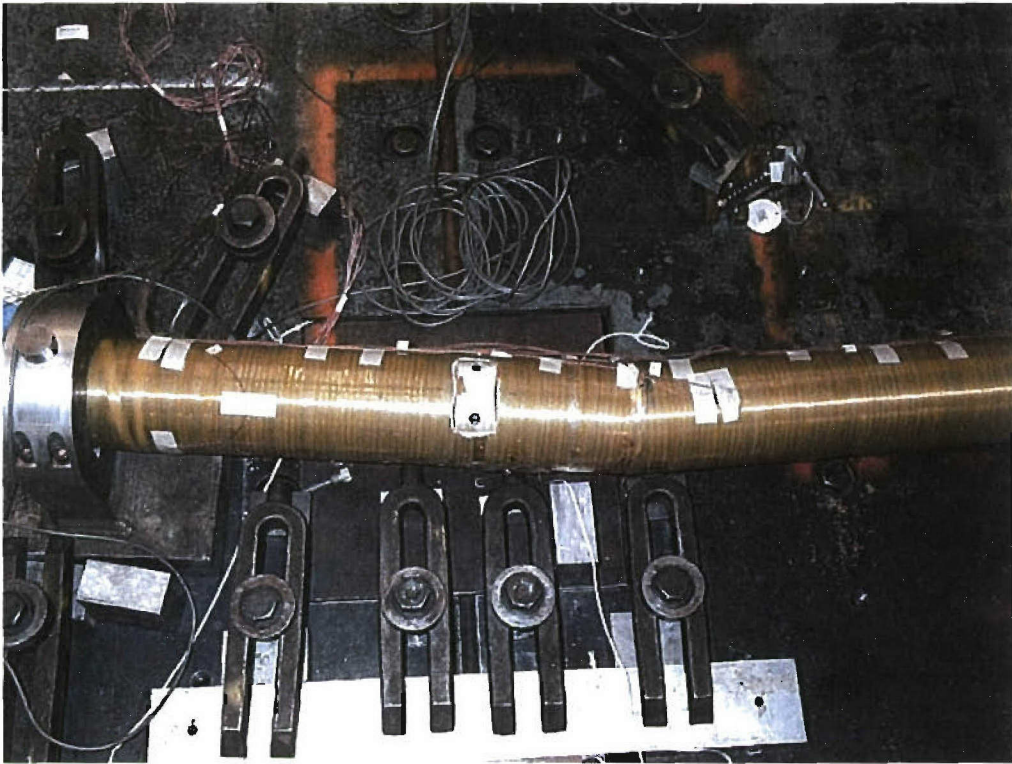

FIGURE D-14. Failure Photograph 1.



FIGURE D-15. Failure Photograph 2.

SUMMARY

The C⁴Q composite blue tube passed the ultimate bending test. The test was performed with hot/wet conditions and impact damage to the tube. Based on the required load of 7480 pounds and the failure of the tube at 8109 pounds, the ultimate M.S. for the damaged tube is as shown in Equation D-3.

$$M.S. = \frac{8109}{7480} - 1 = +0.08 \quad (D-3)$$

(This page intentionally left blank.)

Appendix E
COMPOSITE CASE CAPTIVE CARRY QUALIFICATION (C⁴Q)
BLUE TUBE FORWARD HANGER TEST PLAN

(This page intentionally left blank.)

1.0 INTRODUCTION

This test plan describes the requirements of the Insensitive Munitions Technology Transition Program (IMTTP) Composite Case Captive Carry Qualification (C⁴Q) composite structural verification tests. The forward hanger test is an ultimate load test of the forward hanger to missile body joint.

2.0 OBJECTIVE

The primary purpose of this test is to verify that design requirements are met. This test plan provides the overall instructions for performing the test.

3.0 TEST DESCRIPTION

The test requirements, as defined by the loads given in the design criteria, will be demonstrated via yield and ultimate testing.

Yield testing consists of applying limit loading (4875-pound side load to the hanger) times a 1.15 factor for a total applied load of 5606 pounds.

Ultimate testing consists of applying limit load times a 1.5 factor for ultimate testing, resulting in a total applied load of 7312 pounds.

The success criteria are as follows. Yield testing shall be considered successful if the case and hanger withstand yield load without anomalous behavior that would be indicative of their inability to perform their intended use. This shall be determined by inspection (visual and dimensional) and comparison of data (strains and deflections) with predicted values.

Ultimate load testing shall be considered successful if the case and hanger fail in the predicted manner at 1.5 or higher load factor.

3.1 TEST ARTICLE DESCRIPTION

The test article consists of the forward part of an IMTTP C⁴Q composite tube (Serial Number 003) shown in Figure E-1. (Note: All of the figures are found at the end of this test plan.) The test article consists of a segment of the composite tube with the forward hanger attached. The segment is 35 inches in length (cut 15 inches aft of the forward of the hanger). The forward hanger bolts are installed wet with epoxy at a torque of 240 in-lb.

3.2 TEST FACILITIES

The test facility is located at the Code 476300D environmental laboratory. Hanger tests will be done on the static frame tester.

The test equipment for the bending moment test consists of a hydraulic load jack, load cell, strain gages, and signal conditioning and recording equipment.

The test fixturing to be used for the hanger test will include a hanger tie-down block (with launcher-like interface), a loading beam, and connecting straps. The layout of the test fixture is shown in Figure E-2.

4.0 INSTRUMENTATION AND DATA REQUIREMENTS

The instrumentation requirements for these tests will be the same for both proof (yield) and ultimate tests. All strain gages are 45-degree rectangular rosette (MM CEA-06-125 UR-350) gages. The placement of the instrumentation is shown in Figure E-3.

The accuracy requirements for the instrumentation through the data recording system shall be as provided in Table E-1.

TABLE E-1. Accuracy Requirements for Instrumentation.

Strain Gages	$\pm 0.08\%$ strain
Load Cell	± 10.0 lb
Displacement Potentiometers	± 0.01 inch
Thermocouples	$\pm 5^\circ\text{F}$

The test data shall be reduced and plotted at five samples per second. Two copies of all printouts and plots are required. The digital listings (printouts) will have the strain and displacement as a function of load. Digital plotting will be in the format provided in Table E-2.

TABLE E-2. Digital Plotting Format.

Instrumentation	Abscissa	Ordinate
Load (shear load) cell	Time, seconds	0 to 20,000 lb
Strain gages (SG1-SG12)	0 to 20,000 lb	-3.50 to 3.50%

5.0 TEST PROCEDURE AND SETUP

5.1 MAXIMUM HANGER LOAD TESTS

Prior to the tests, the test director will define selected priority data, which will be immediately processed and reviewed prior to proceeding with the testing.

The general test procedures are as follows.

1. Attach the load actuator stinger to the loading beam.
2. Place article into the static test frame.
3. Attach the forward hanger to the hanger tie-down block.
4. Connect all instrumentation.
5. Take pretest photographs of the test setup.
6. Slowly raise the load to 1000 pounds and then lower the load back to zero. Observe strain gage and displacement readings. Verify all instrumentation is operating properly.
7. Once correct instrumentation operation has been confirmed, start recording data and begin to raise the load in accordance with Figure E-4.
8. Turn off instrumentation and disconnect all lead wiring and fixtures.
9. Note all anomalies during and after the testing.
10. Take post-test photographs of the test setup.
11. Remove test article (see Sections 5.1.1 and 5.1.2).

5.1.1 Test Precautions

The composite tube specimen will be placed in an isolated area during the test. Hazardous flying debris is expected during the ultimate test and all precautions shall be taken to avoid exposure to the debris. Extreme care should be taken in handling the remains of the case after the test is completed. All the bending moment tests must comply with all Code 476300D safety requirements.

5.1.2 Test Article Disposition

The composite tube and hanger joint will be post inspected after proof (yield) and ultimate tests by Code 476J00D personnel. The tube will be delivered to Code 476J00D for sectioning into coupons and cylindrical test articles after the ultimate test.

6.0 SUMMARY

Following each test, a summarized report shall be drafted describing the test and the results. Pertinent diagrams and graphs shall be included.

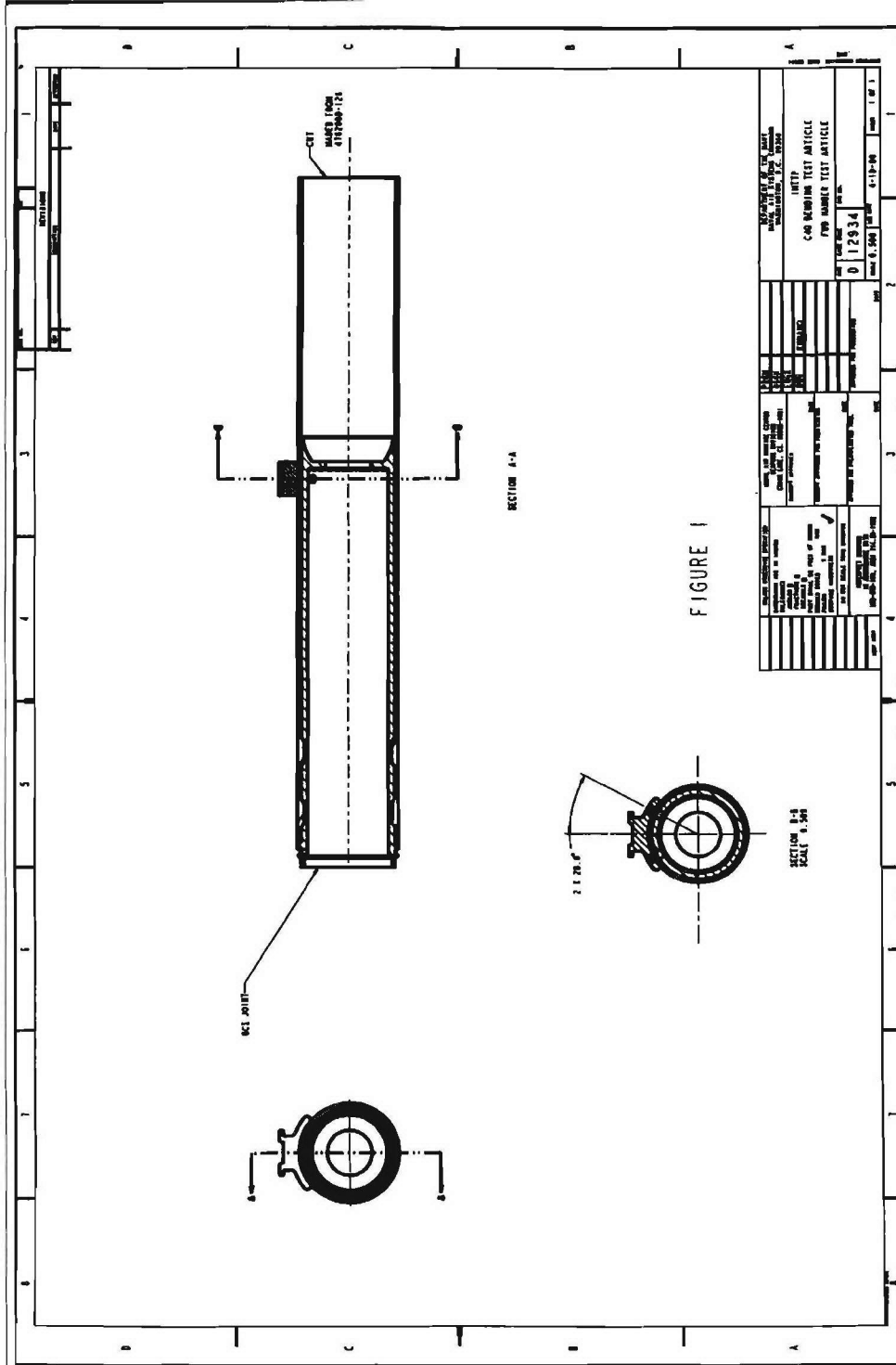

FIGURE E-1. Forward Part of IMTTP C⁴Q Composite Tube.

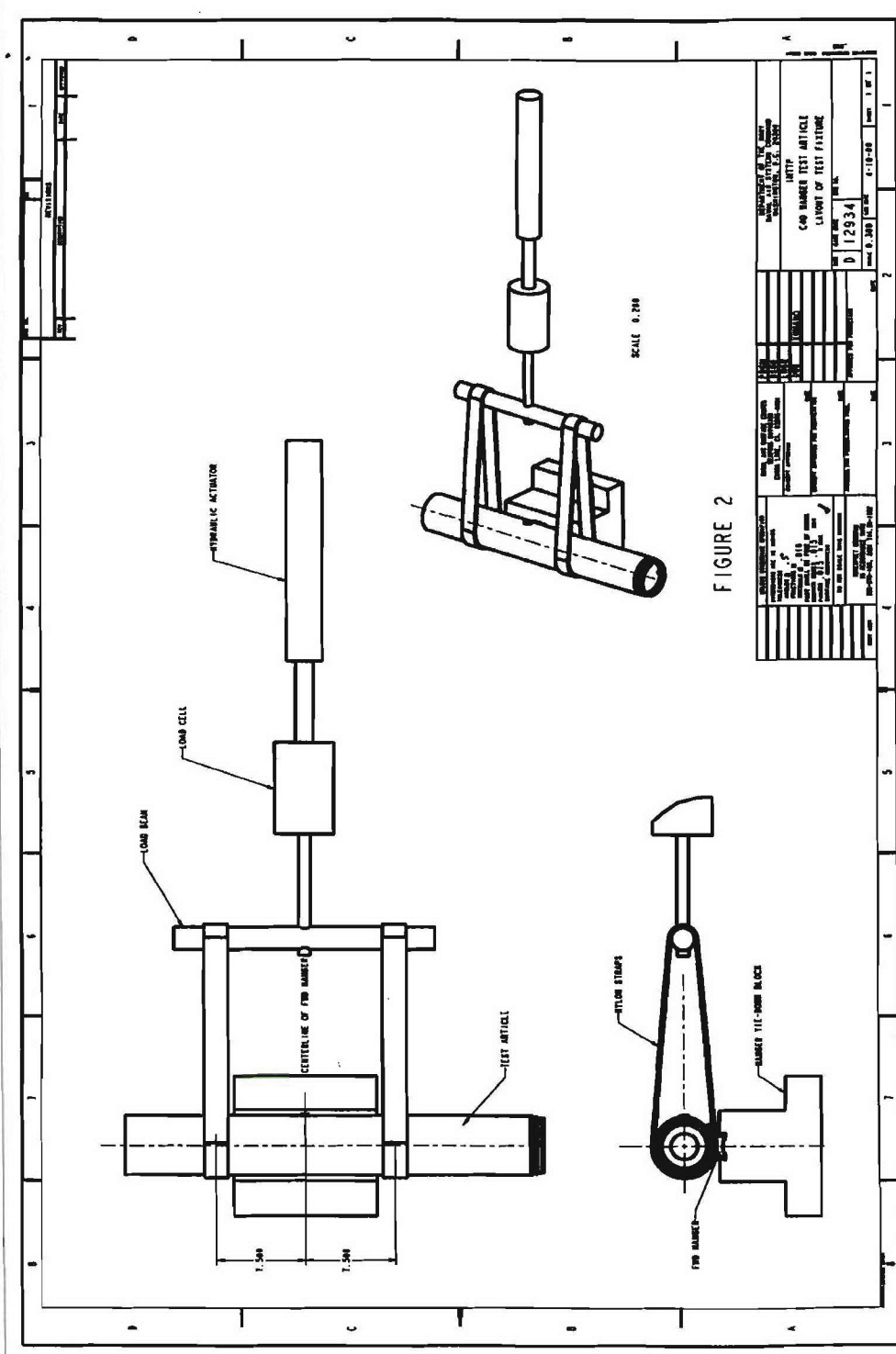

FIGURE E-2. Text Fixture Layout.

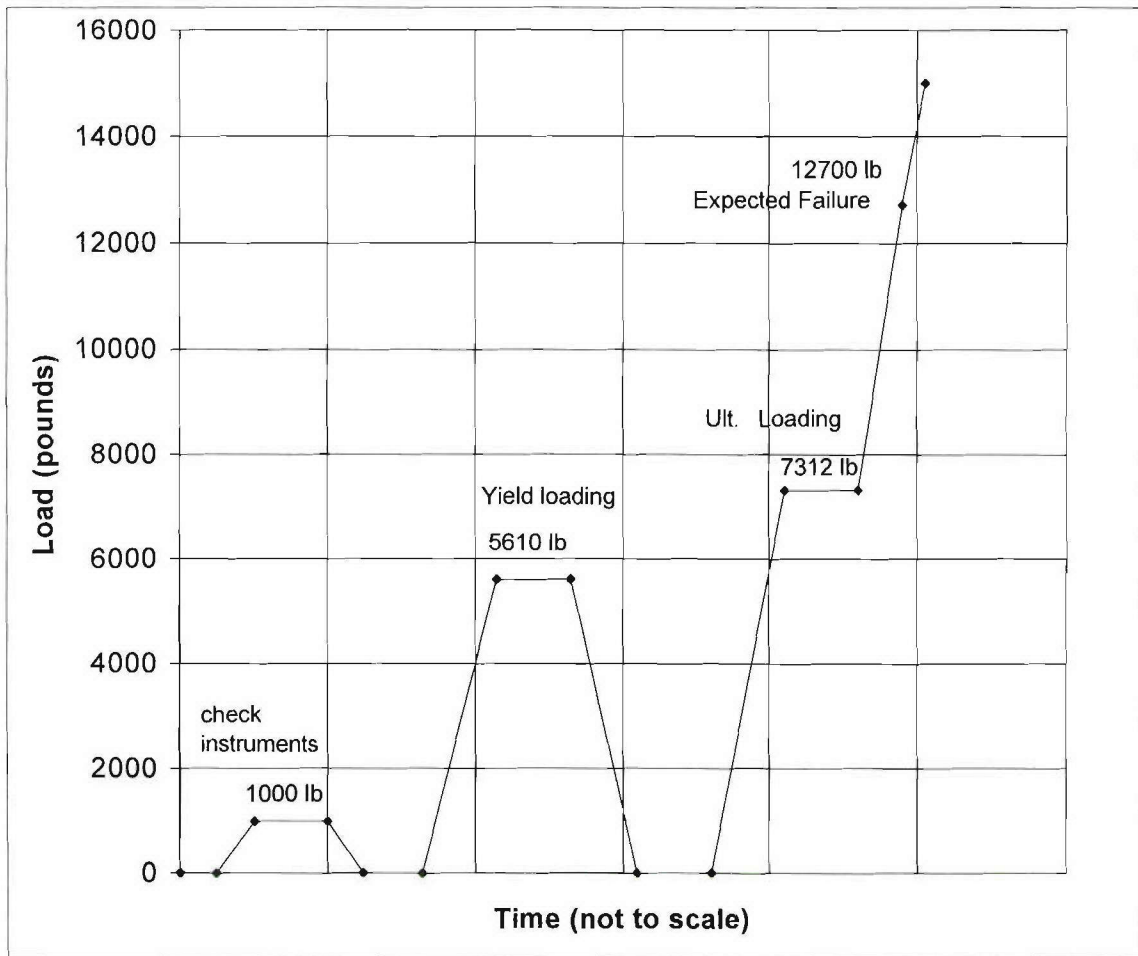

FIGURE E-4. Load Schedule.

Appendix F
COMPOSITE CASE CAPTIVE CARRY QUALIFICATION (C⁴Q)
BLUE TUBE FORWARD HANGER TEST REPORT

(This page intentionally left blank.)

CONTENTS

Test Description	F-5
Introduction.....	F-5
Test Specimen.....	F-5
Loading Condition.....	F-5
Analysis of Loading	F-6
Forward Hanger Loading Development.....	F-6
Test Results	F-7
Yield Test.....	F-8
Ultimate Test.....	F-8
Summary.....	F-10

Figures:

F-1. All-up-round (AUR) Structural Layout.....	F-5
F-2. Forward Hanger Loading Fixture	F-6
F-3. Forward Hanger Test Load History.....	F-7
F-4. Yield Test Hoop Strain Data History.....	F-8
F-5. Ultimate Test Hoop Strain Data.....	F-9
F-6. Ultimate Load Test Hanger Failure Mode.....	F-9
F-7. Ultimate Load Test Hanger Failure Mode (Close-up).....	F-10

(This page intentionally left blank.)

TEST DESCRIPTION

INTRODUCTION

The Composite Case Captive Carry Qualification (C⁴Q) blue tube forward hanger test is a full-scale structural test of the composite blue tube. The goal was to simulate the worst-case captive carriage load on the forward hanger. This test, in combination with other testing, is intended to demonstrate the structural adequacy of the C⁴Q blue tube design. This test is performed on a full-scale specimen at room temperature. The test yielded a margin of safety (M.S.) of +1.60 for the hanger while at station 1 or 9 (wing tip) of the F/A-18C/D. This was with a 1.5 factor of safety for ultimate load.

TEST SPECIMEN

For reference, Figure F-1 shows the basic structural layout of the CATM-9M with the C⁴Q hardware. The test article consists of a segment of the composite tube with the forward hanger attached. The segment is 35 inches in length (cut 15 inches aft of the forward of the hanger). The forward hanger bolts are installed wet with epoxy at a torque of 240 in-lb.

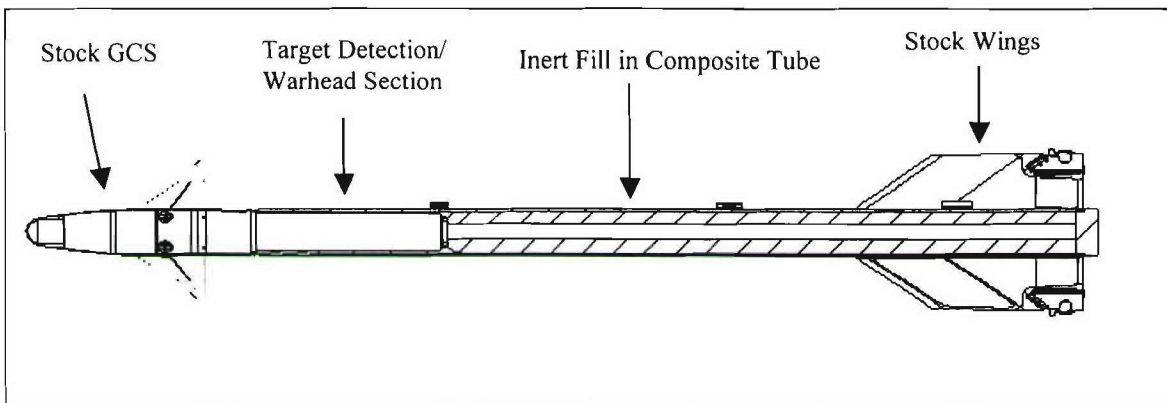

FIGURE F-1. All-up-round (AUR) Structural Layout.

LOADING CONDITION

The specimen was loaded to simulate the load direction and magnitude of the forward hanger on the wing tip stations during the worst-case maneuver (the Mk 84 bomb release). The loading was raised to yield level and returned to zero in order to confirm that no permanent deformation occurred. The loading was then raised until it produced failure. The specimen, fixtures, and loading sequence can be seen in detail in the test plan (Appendix E) and in Figure F-2.

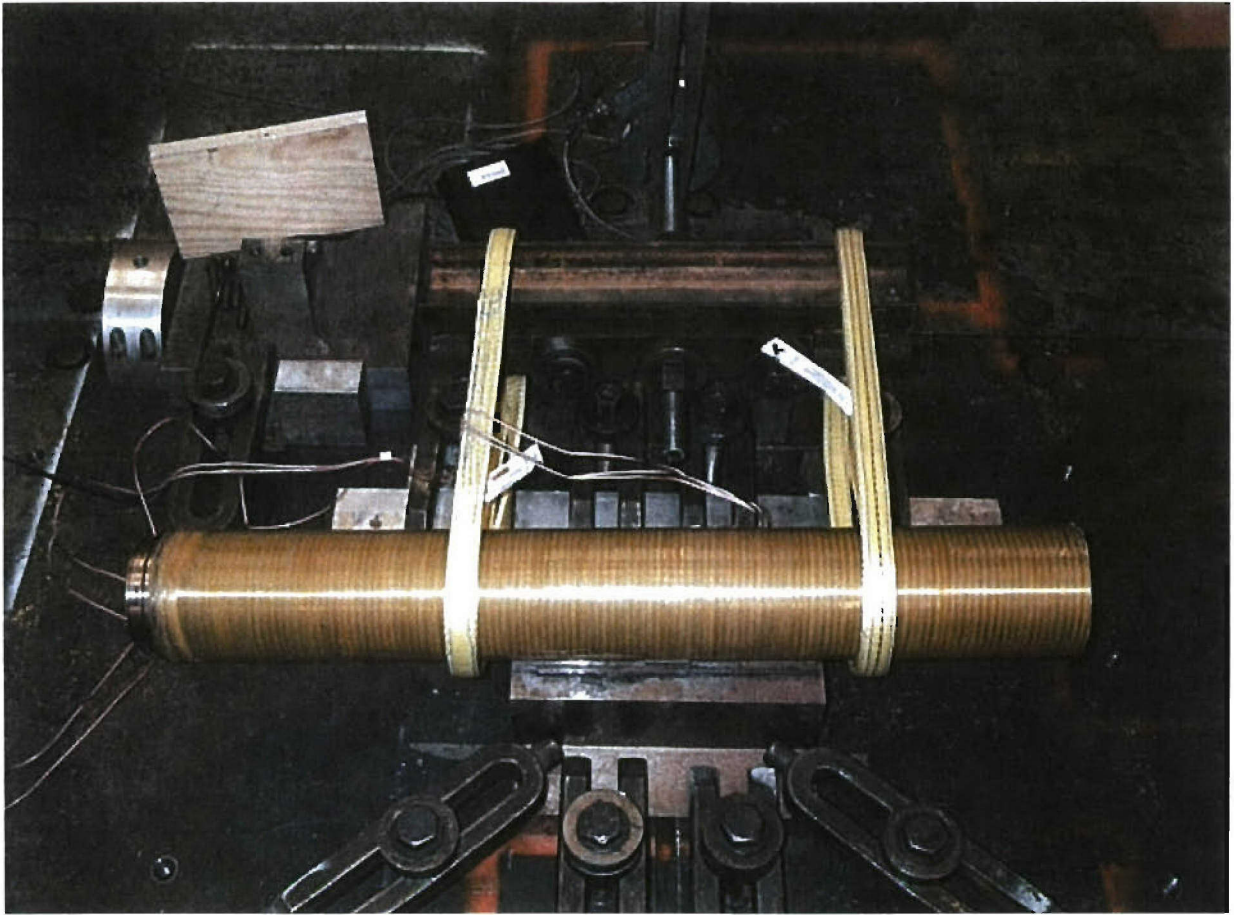

FIGURE F-2. Forward Hanger Loading Fixture.

ANALYSIS OF LOADING

FORWARD HANGER LOADING DEVELOPMENT

The development of the forward hanger loading value is based on the assumption that the metal hanger or the hanger attachment bolts will fail before the composite tube. Therefore, the load requirement is not exaggerated to cover the reduced composite material properties due to hot/wet conditions and impact damage. This assumption was proved to be correct during testing. The magnitude of the load corresponds to the reactions in the finite element loads model at the forward hanger due to the Mk 84 release condition (worst-case limit load). This is a limit load in the missile Y direction of 4875 pounds.

Equations F-1 and F-2 apply.

$$\text{Yield Load} = 4875 \times 1.15 = 5610 \text{ pounds} \quad (\text{F-1})$$

$$\text{Ultimate Load} = 4875 \times 1.50 = 7310 \text{ pounds} \quad (\text{F-2})$$

TEST RESULTS

The test plan is included as Appendix E. It contains the procedures and figures needed to execute the test. The test was performed on 4 May 2000. All fixtures and instrumentation performed as expected. The test was performed in two stages. The first stage was to increase the load to the yield load and back down to zero. The second stage was to increase the load to failure. Figure F-3 shows the actual applied load history.

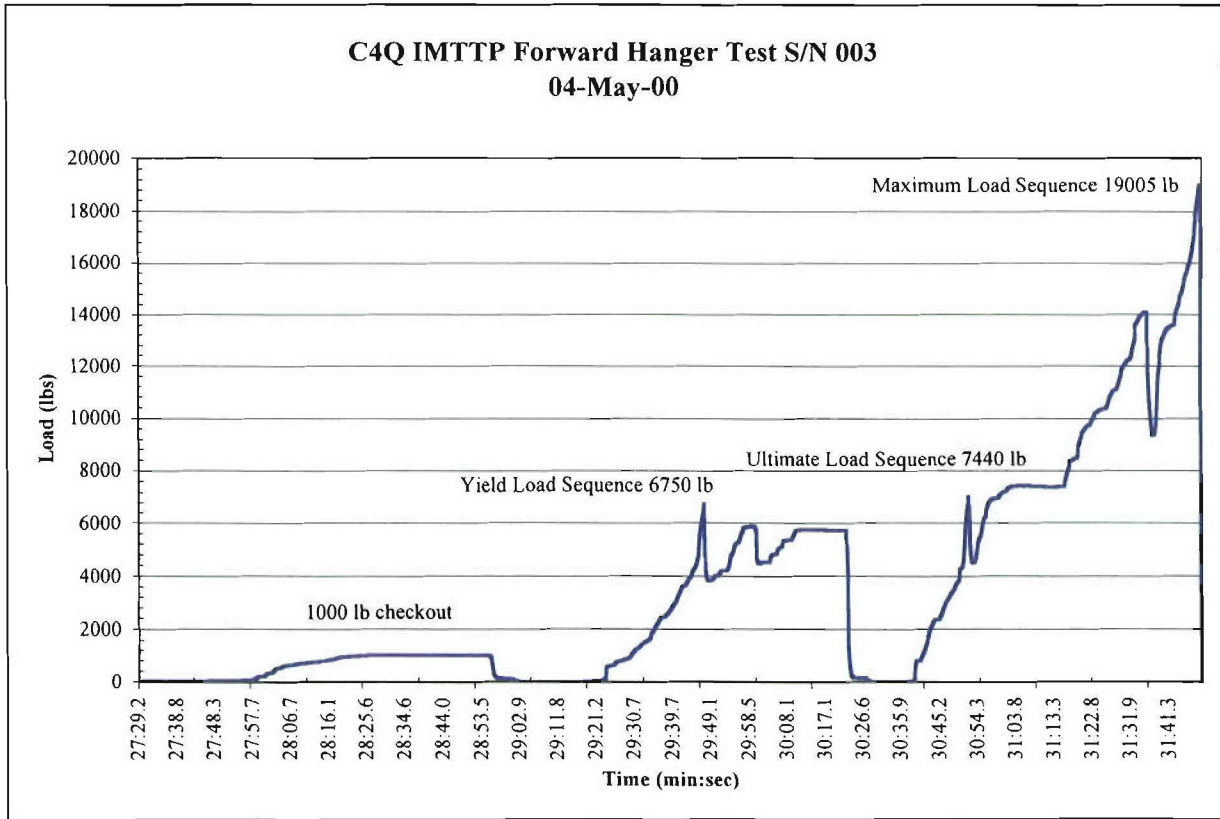

FIGURE F-3. Forward Hanger Test Load History.

YIELD TEST

Figure F-4 shows the hoop strain data for the yield test. This was the dominant strain direction and provides the best indication of the structural response. As seen in Figure F-3, the load was somewhat variable while holding the yield value of 5610 pounds. This is seen in the yield data as the "scribble back and forth" at the top of the graph. The strain data do return to the original value, which meets the yield criteria. No deformation or damage was observed.

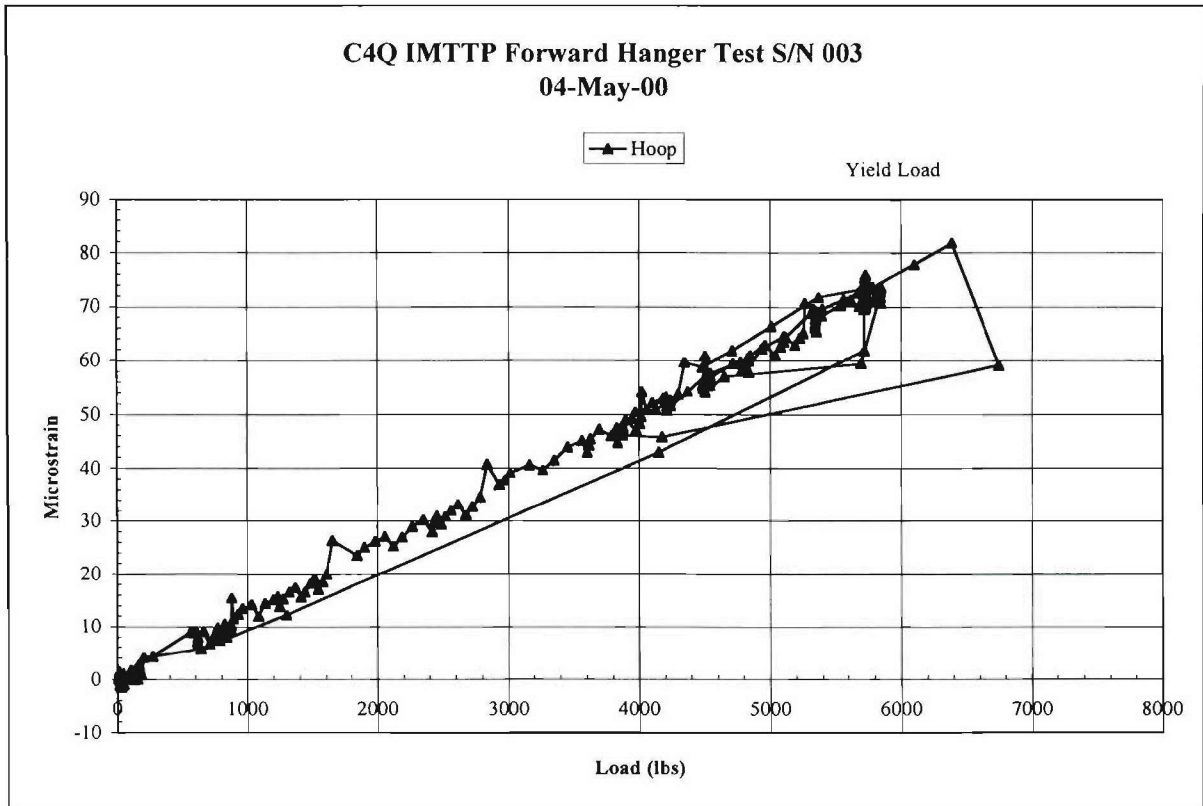

FIGURE F-4. Yield Test Hoop Strain Data History.

ULTIMATE TEST

The next stage in the test was to increase the load on the tube until failure. The strain data are presented in Figure F-5.

As the load was increased, there were no signs of progressive damage until the forward hanger failed at 19,005 pounds. The failure was a catastrophic net section tensile failure at the bolt holes. Figures F-6 and F-7 show the failure.

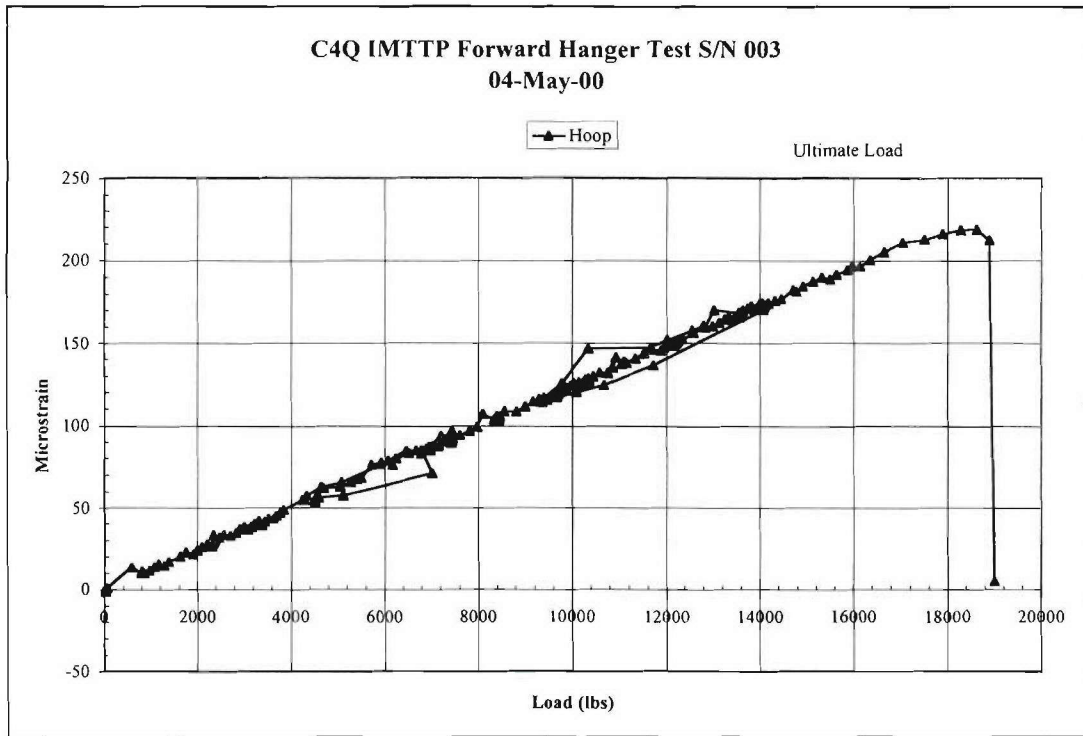

FIGURE F-5. Ultimate Test Hoop Strain Data.

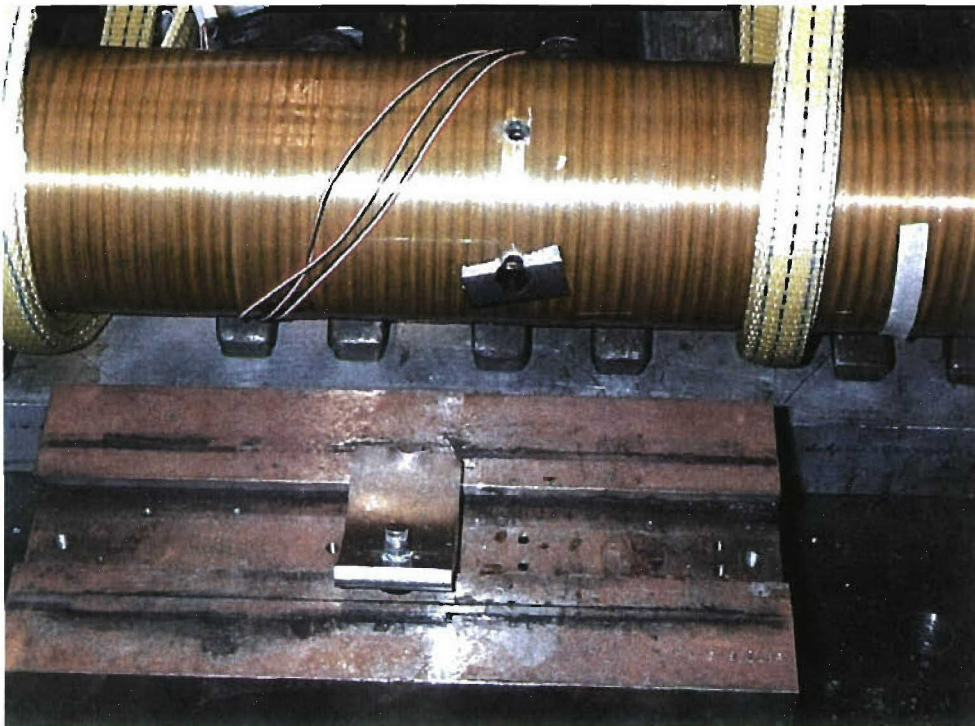

FIGURE F-6. Ultimate Load Test Hanger Failure Mode.

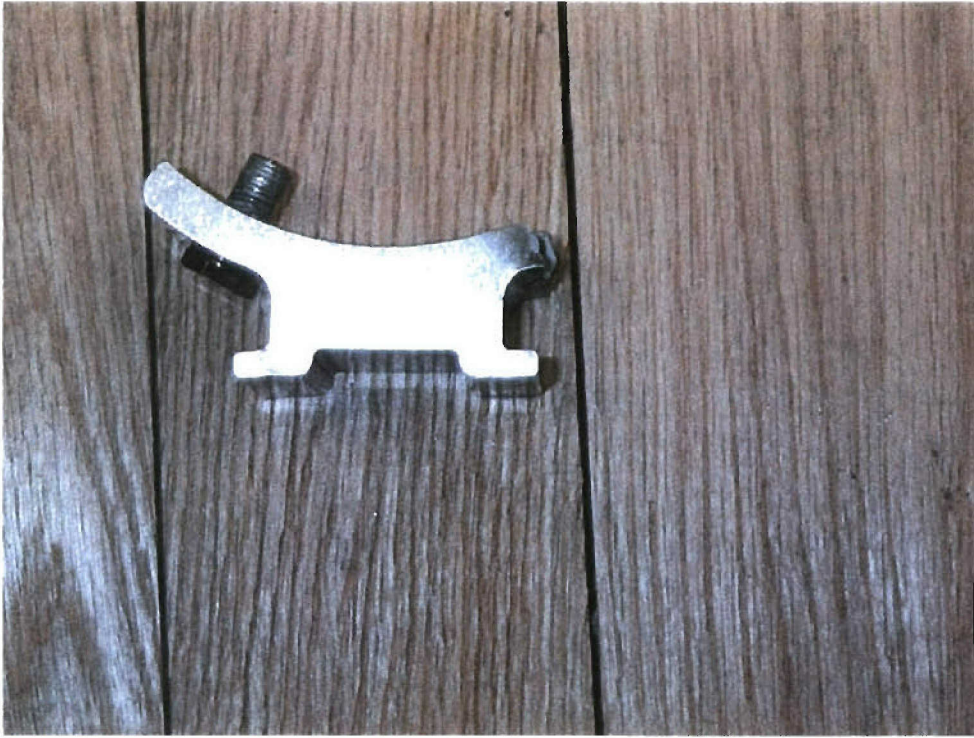

FIGURE F-7. Ultimate Load Test Hanger Failure Mode (Close-up).

SUMMARY

The C⁴Q composite blue tube passed the ultimate forward hanger load test. Based on the required load of 7310 pounds and the failure of the tube at 19,005 pounds, the M.S. for the forward hanger is determined via Equation F-3.

$$M.S. = \frac{19005}{7310} - 1 = +1.60 \quad (F-3)$$

Appendix G
COMPOSITE CASE CAPTIVE CARRY QUALIFICATION (C⁴Q)
BLUE TUBE MIDDLE HANGER TEST PLAN

(This page intentionally left blank.)

1.0 INTRODUCTION

This test plan describes the requirements of the Insensitive Munitions Technology Transition Program (IMTTP) Composite Case Captive Carry Qualification (C⁴Q) composite structural verification tests. The middle hanger test is an ultimate load test of the middle hanger to missile body joint.

2.0 OBJECTIVE

The primary purpose of this test is to verify that design requirements are met. This test plan provides the overall instructions for performing the test.

3.0 TEST DESCRIPTION

The test requirements, as defined by the loads given in the design criteria, will be demonstrated via yield and ultimate testing.

Yield testing consists of applying limit loading (2899-pound side load to the hanger) times a 1.15 factor for a total applied load of 3333 pounds. This is increased to account for the composite knockdowns (times 1.25 for impact and times 1.25 for hygrothermal) for a 5200-pound yield load.

Ultimate testing consists of applying limit load times a 1.5 factor for ultimate testing, resulting in a total applied load of 4348 pounds. This is increased to account for the composite knockdowns (times 1.25 for impact and times 1.25 for hygrothermal) for a 6800-pound ultimate load.

The success criteria are as follows. Yield testing shall be considered successful if the case and hanger withstand yield load without anomalous behavior that would be indicative of their inability to perform their intended use. This shall be determined by inspection (visual and dimensional) and comparison of data (strains and deflections) with predicted values.

Ultimate load testing shall be considered successful if the case and hanger fail in the predicted manner at 1.5 or higher load factor.

3.1 TEST ARTICLE DESCRIPTION

The test article consists of the middle part of an IMTTP C⁴Q composite tube (Serial Number 006), shown here in Figure G-1. (Note: All of the figures are provided at the end of this document.) The test article consists of a segment of the composite tube with the middle hanger attached. The segment is 24 inches in length.

The smaller (3/16-32) mid-body hanger bolts (476200D130-2) are installed wet with epoxy and torqued to 100 in-lb. The larger (1/4-28) mid-body hanger bolts (476200D130-1) are also installed wet with epoxy. They are torqued to 250 in-lb.

3.2 TEST FACILITIES

The test facility is located at the Code 476300D environmental laboratory. Hanger tests will be done on the static frame tester.

The test equipment for the bending moment test consists of a hydraulic load jack, load cell, strain gages, and signal conditioning and recording equipment.

The test fixturing to be used for the hanger test will include a hanger tie-down block (with launcher-like interface), a loading beam, and connecting straps. The layout of the test fixture is shown in Figure G-2.

4.0 INSTRUMENTATION AND DATA REQUIREMENTS

The instrumentation requirements for these tests will be the same for both proof (yield) and ultimate tests. All strain gages are 45-degree rectangular rosette (MM CEA-06-125 UR-350) gages. The placement of the instrumentation is shown in Figure G-3.

The accuracy requirements for the instrumentation through the data recording system shall be as provided in Table G-1.

TABLE G-1. Accuracy Requirements for Instrumentation.

Strain Gages	±0.08% strain
Load Cell	±10.0 lb
Displacement Potentiometers	±0.01 inch
Thermocouples	±5°F

The test data shall be reduced and plotted at five samples per second. Two copies of all printouts and plots are required. The digital listings (printouts) will have the strain and displacement as a function of load. Digital plotting will be in the format provided in Table G-2.

TABLE G-2. Digital Plotting Format.

Instrumentation	Abscissa	Ordinate
Load (shear load) cell	Time, seconds	0 to 20,000 lb
Strain gages (SG1-SG12)	0 to 20,000 lb	-3.50 to 3.50%

5.0 TEST PROCEDURE AND SETUP

5.1 MAXIMUM HANGER LOAD TESTS

Prior to the tests, the test director will define selected priority data, which will be immediately processed and reviewed prior to proceeding with the testing.

The general test procedures are as follows.

1. Attach the load actuator stinger to the loading beam.
2. Place article into the static test frame.
3. Attach the forward hanger to the hanger tie-down block.
4. Connect all instrumentation.
5. Take pretest photographs of the test setup.
6. Slowly raise the load to 1000 pounds and then lower the load back to zero. Observe strain gage and displacement readings. Verify all instrumentation is operating properly.
7. Once correct instrumentation operation has been confirmed, start recording data and begin to raise the load in accordance with Figure G-4.
8. Turn off instrumentation and disconnect all lead wiring and fixtures.
9. Note all anomalies during and after the testing.
10. Take post-test photographs of the test setup.
11. Remove test article (see Sections 5.1.1 and 5.1.2).

5.1.1 Test Precautions

The composite tube specimen will be placed in an isolated area during the test. Hazardous flying debris is expected during the ultimate test and all precautions shall be taken to avoid exposure to the debris. Extreme care should be taken in handling the remains of the case after the test is completed. All the bending moment tests must comply with all Code 476300D safety requirements.

5.1.2 Test Article Disposition

The composite tube and hanger joint will be post inspected after proof (yield) and ultimate tests by Code 476J00D personnel. The tube will be delivered to Code 476J00D for sectioning into coupons and cylindrical test articles after the ultimate test.

6.0 SUMMARY

Following this hanger load test, a summarized report shall be drafted describing the test and the results. Pertinent diagrams and graphs shall be included.

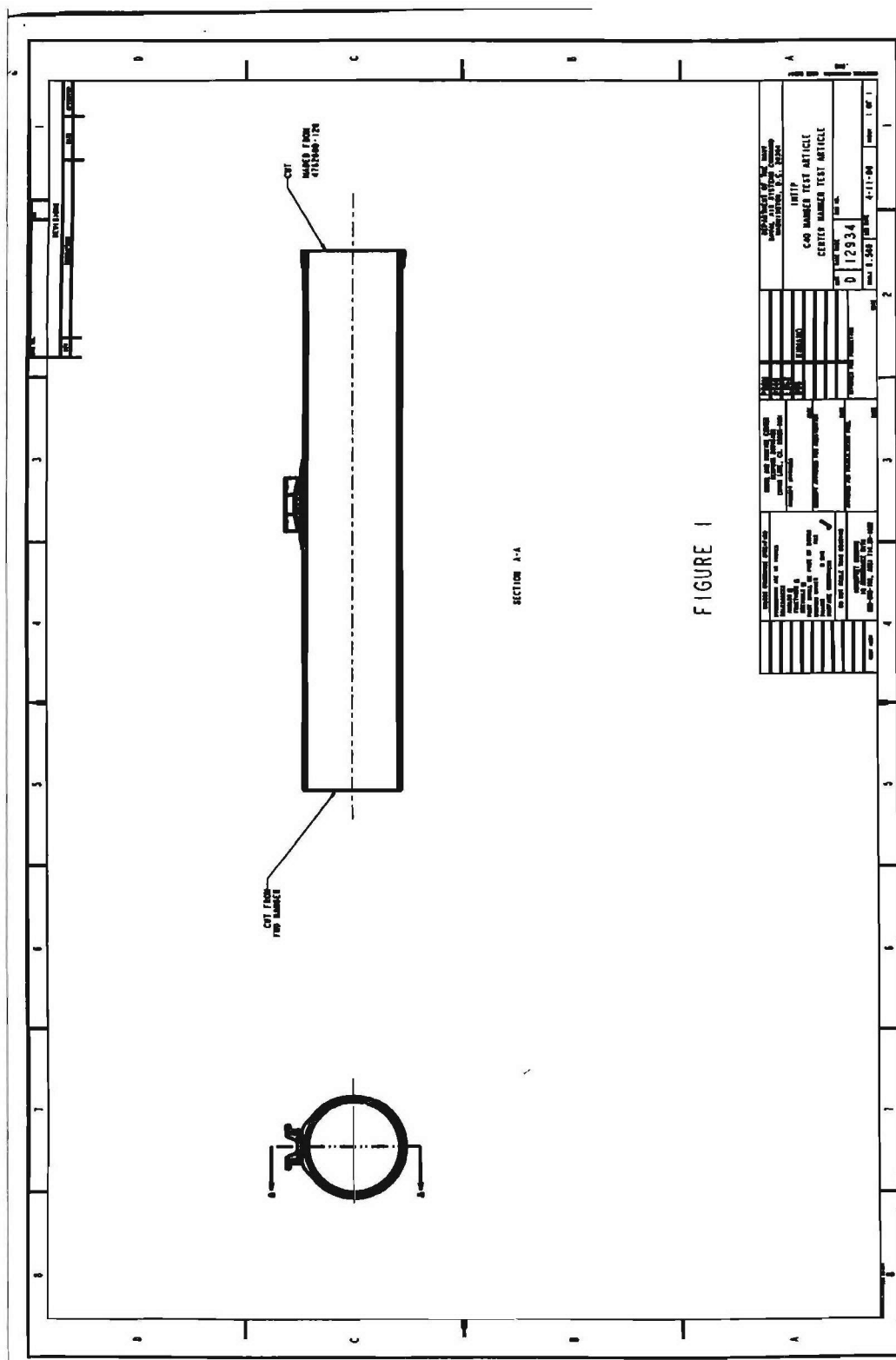

FIGURE G-1. Middle Part of IMTTP C⁴Q Composite Tube.

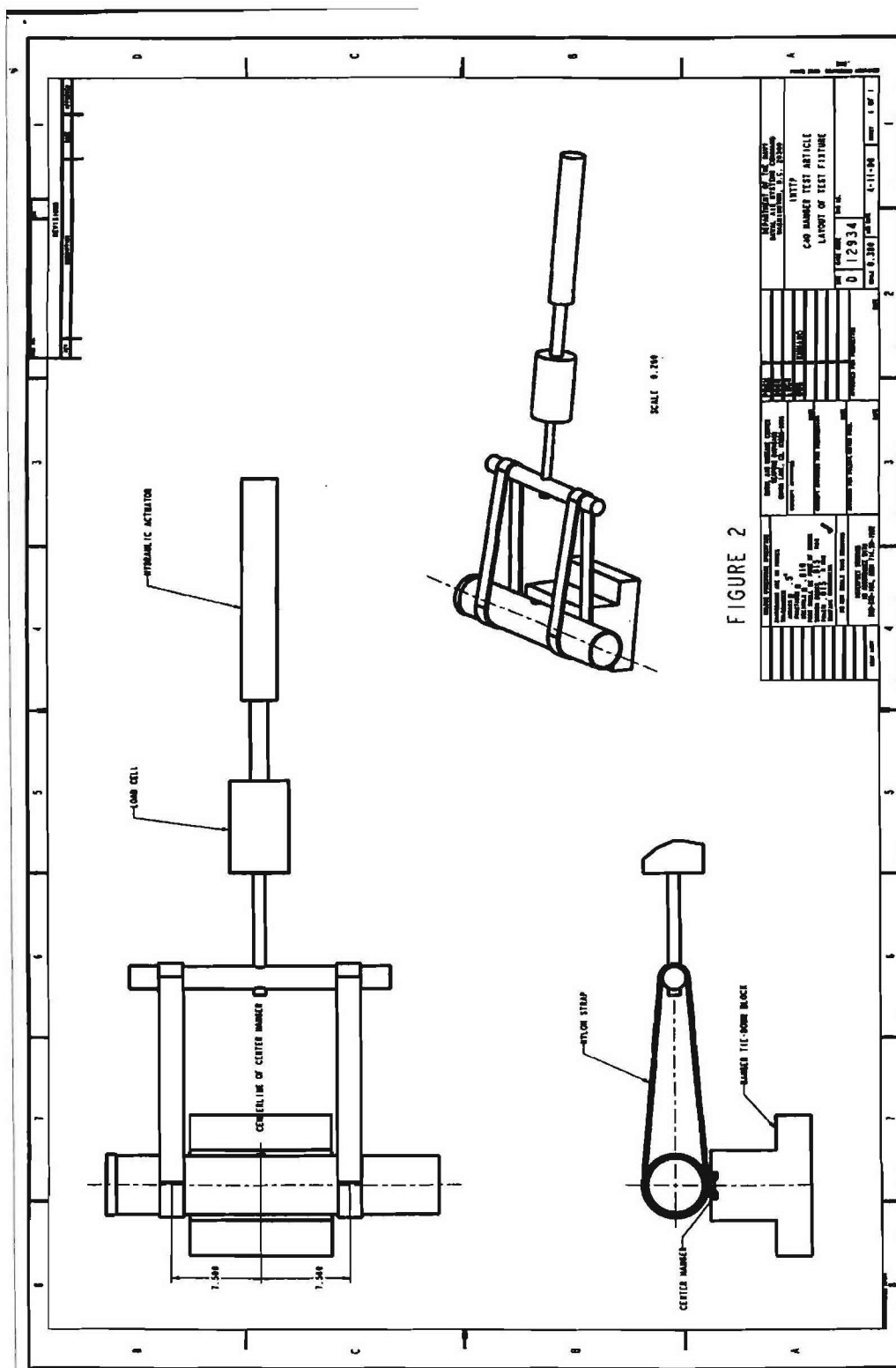

FIGURE G-2. Text Fixture Layout.

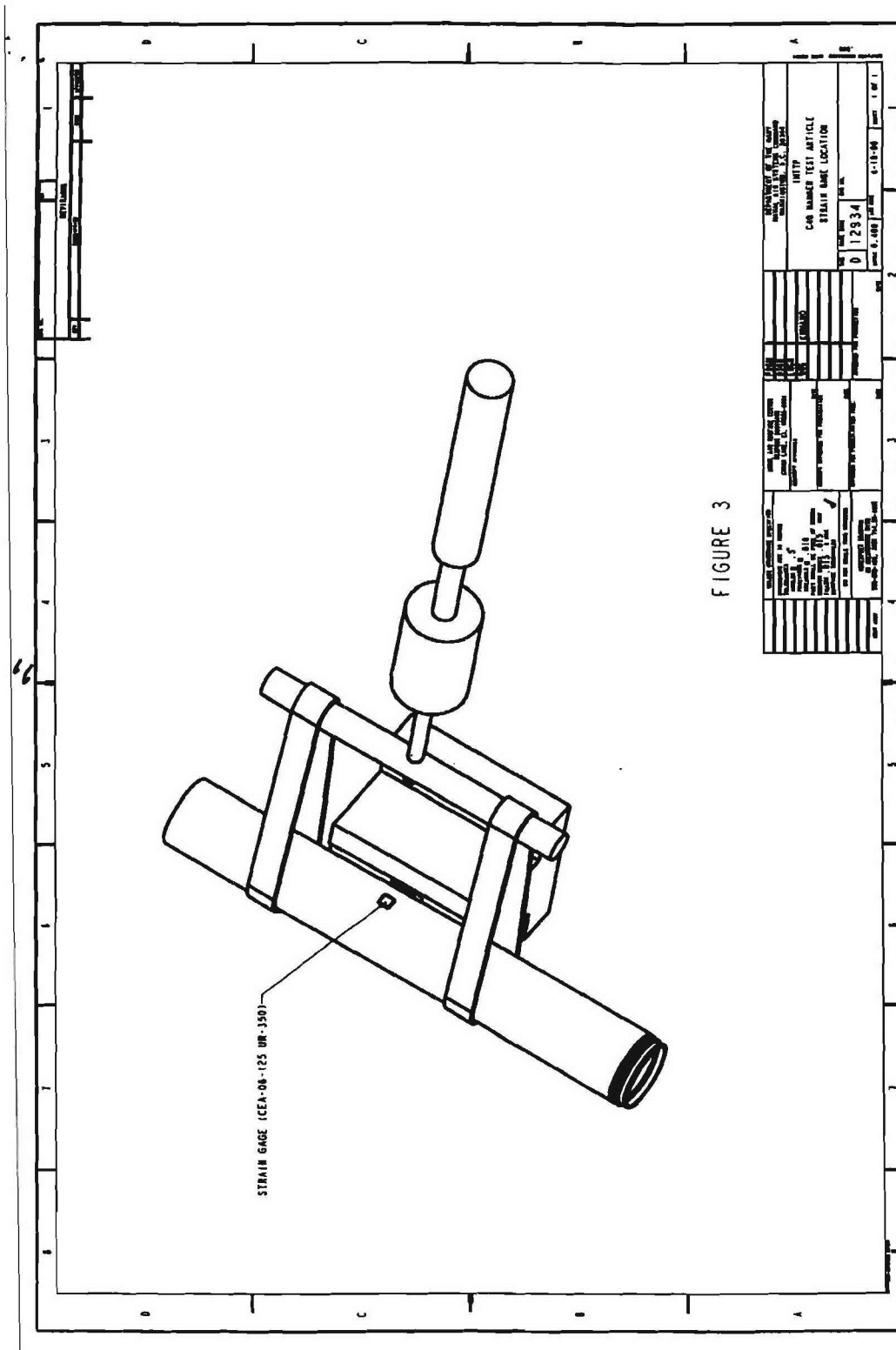

FIGURE 3

FIGURE G-3. Instrumentation Placement.

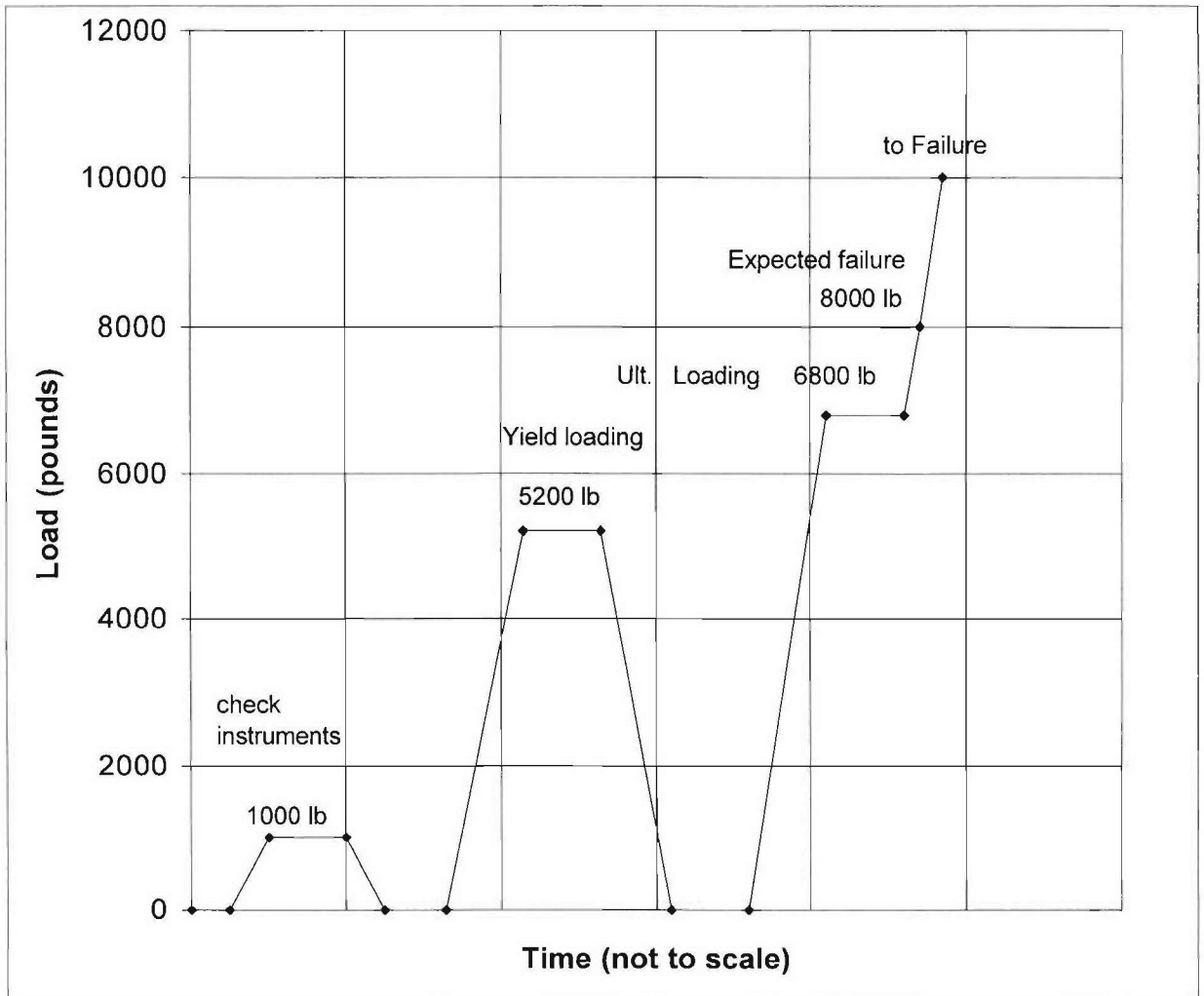

FIGURE G-4. Load Schedule.

Appendix H
COMPOSITE CASE CAPTIVE CARRY QUALIFICATION (C⁴Q)
BLUE TUBE MIDDLE HANGER TEST REPORT

(This page intentionally left blank.)

CONTENTS

Test Description	H-5
Introduction.....	H-5
Test Specimen.....	H-5
Loading Condition.....	H-6
Analysis of Loading	H-6
Middle Hanger Loading Development	H-6
Test Results	H-7
Yield Test.....	H-7
Ultimate Test.....	H-7
Summary.....	H-13
Specimen Without Release on Hanger Pad	H-13
Specimen With Release on Hanger Pad	H-13

Figures:

H-1. All-up-round (AUR) Structural Layout.....	H-5
H-2. Middle Hanger Loading Fixture	H-6
H-3. Middle Hanger Test Load History (No Release Agent)	H-8
H-4. Middle Hanger Test Load History (With Release Agent).....	H-8
H-5. Yield Test Hoop Strain Data History (No Release).....	H-9
H-6. Yield Test Hoop Strain Data History (With Release).....	H-9
H-7. Ultimate Test Hoop Strain Data (No Release).....	H-10
H-8. Ultimate Test Hoop Strain Data (With Release).....	H-10
H-9. Middle Hanger Failure (No Release), Inside View.....	H-11
H-10. Middle Hanger Failure (No Release), Outside View	H-12
H-11. Middle Hanger Failure (With Release), Inside View	H-12
H-12. Middle Hanger Failure (With Release), Outside View.....	H-13

(This page intentionally left blank.)

TEST DESCRIPTION

INTRODUCTION

The Composite Case Captive Carry Qualification (C⁴Q) blue tube middle hanger test is a full-scale structural test of the composite blue tube. The goal was to simulate the worst-case captive carriage load on the middle hanger. This test, in combination with other testing, is intended to demonstrate the structural adequacy of the C⁴Q blue tube design. This test is performed on a full-scale specimen at room temperature. The hanger loads are worst case for station 1 or 9 (wing tip) of the F/A-18C/D. The test showed a margin of safety (M.S.) of +0.15 for the middle hanger. This was with a 1.5 factor of safety for ultimate load and an additional 1.25 factor to cover the hot/wet knockdown and 1.25 to cover the impact damage knockdown. The same test was performed for a middle hanger with a deliberate disbond between the metal and composite. It showed a margin of -0.09 for ultimate with the same factors as before.

TEST SPECIMEN

For reference, Figure H-1 shows the basic structural layout of the CATM-9M with the C⁴Q hardware. The test article consists of the middle segment of the composite tube with the middle hanger attached. The segment is 24 inches in length (cut 12 inches on either side of the middle hanger). The smaller (3/16-32) hanger bolts are installed wet with epoxy at a torque of 100 in-lb. The larger (1/4-20) bolts are installed wet with epoxy at a torque of 250 in-lb. There were two specimens tested. The first was manufactured according to the Process Specification 0032 and the second included a release agent on the wound-in hanger mounting pad to simulate a disbonded pad.

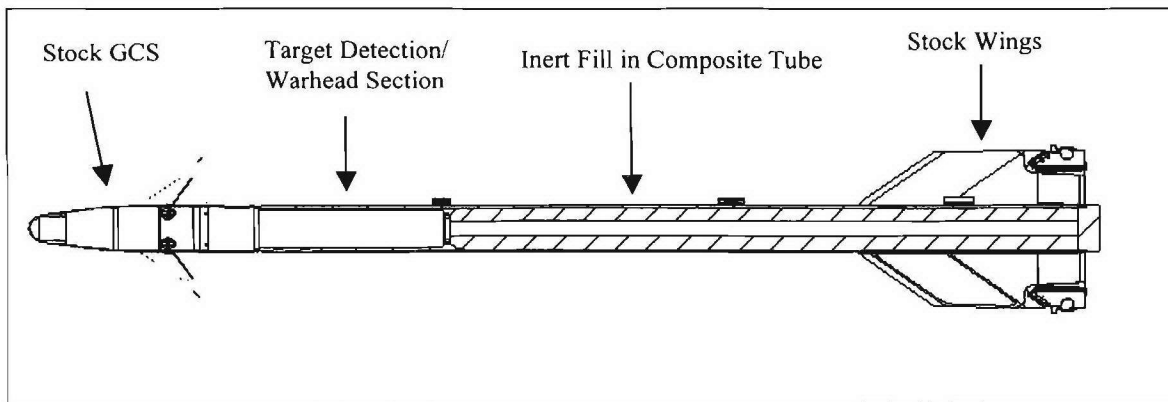

FIGURE H-1. All-up-round (AUR) Structural Layout.

LOADING CONDITION

The specimens were loaded to simulate the load direction and magnitude of the middle hanger on the wing tip stations during the worst-case maneuver (the Mk 84 bomb release). The loading was raised to yield level and returned to zero in order to confirm that no permanent deformation occurred. The loading was then raised until it produced a failure. The specimen, fixtures, and loading sequence can be seen in detail in the test plan (Appendix G) and in Figure H-2.

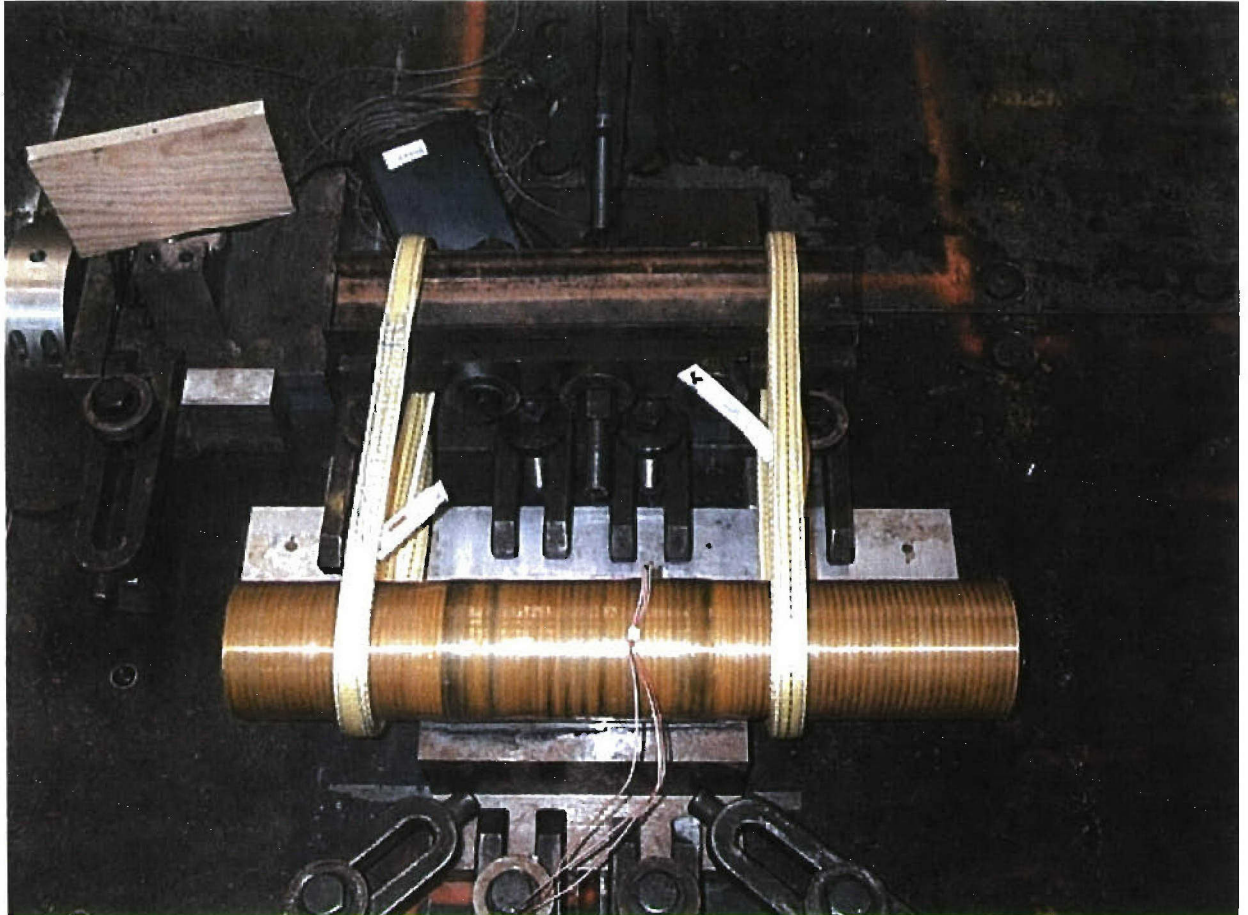

FIGURE H-2. Middle Hanger Loading Fixture.

ANALYSIS OF LOADING

MIDDLE HANGER LOADING DEVELOPMENT

The development of the middle hanger loading value is based on the assumption that the metal hanger or the hanger attachment bolts will fail before the composite tube. This was based on experience in testing of prior programs. Therefore, the load requirement was not exaggerated to cover the reduced composite material properties due to hot/wet conditions and impact damage. This test specimen failure was

in the composite material, so it would have been appropriate to increase the load requirements by 1.25 times 1.25 to cover the material knockdowns. This increased load value is used for the M.S calculations and the second hanger test. The magnitude of the load corresponds to the reactions in the finite element loads model at the middle hanger due to the Mk 84 release condition (worst-case limit load). This is a limit load in the missile Y direction of 2899 pounds.

Equations H-1 through H-4 apply.

$$\text{Yield Load} = 2900 \times 1.15 = 3330 \text{ pounds} \quad (\text{H-1})$$

$$\text{Yield With Knockdowns} = 2900 \times 1.15 \times 1.25 \times 1.25 = 5210 \text{ pounds} \quad (\text{H-2})$$

$$\text{Ultimate Load} = 2900 \times 1.50 = 4350 \text{ pounds} \quad (\text{H-3})$$

$$\text{Ultimate With Knockdowns} = 2900 \times 1.15 \times 1.25 \times 1.25 = 6800 \text{ pounds} \quad (\text{H-4})$$

After the composite failure of the first specimen, we raised the yield and ultimate values to account for the composite material knockdowns.

TEST RESULTS

The test plan is included as Appendix G. It contains the procedures and figures needed to execute the test. The first test was performed on 4 May 2000. All fixtures and instrumentation performed as expected. The test was performed in two stages. The first stage was to increase the load to the yield load and back down to zero. The second stage was to increase the load to ultimate and on up to the end of test limit. Figure H-3 shows the actual applied load history for the first test (no release agent) and Figure H-4 shows it for the specimen with release agent.

YIELD TEST

Figures H-5 and H-6 show the hoop strain data for the yield test. This was the dominant strain direction and provides the best indication of the structural response. Both specimens made cracking sounds during the increase in load. The strain data do not return to the original value, failing the yield test criteria. Visually, the first specimen did not show severe signs of damage, but the second (released) specimen obviously had begun to fail.

ULTIMATE TEST

The next stage in the test was to increase the load on the hangers until failure. The strain data are presented in Figures H-7 and H-8.

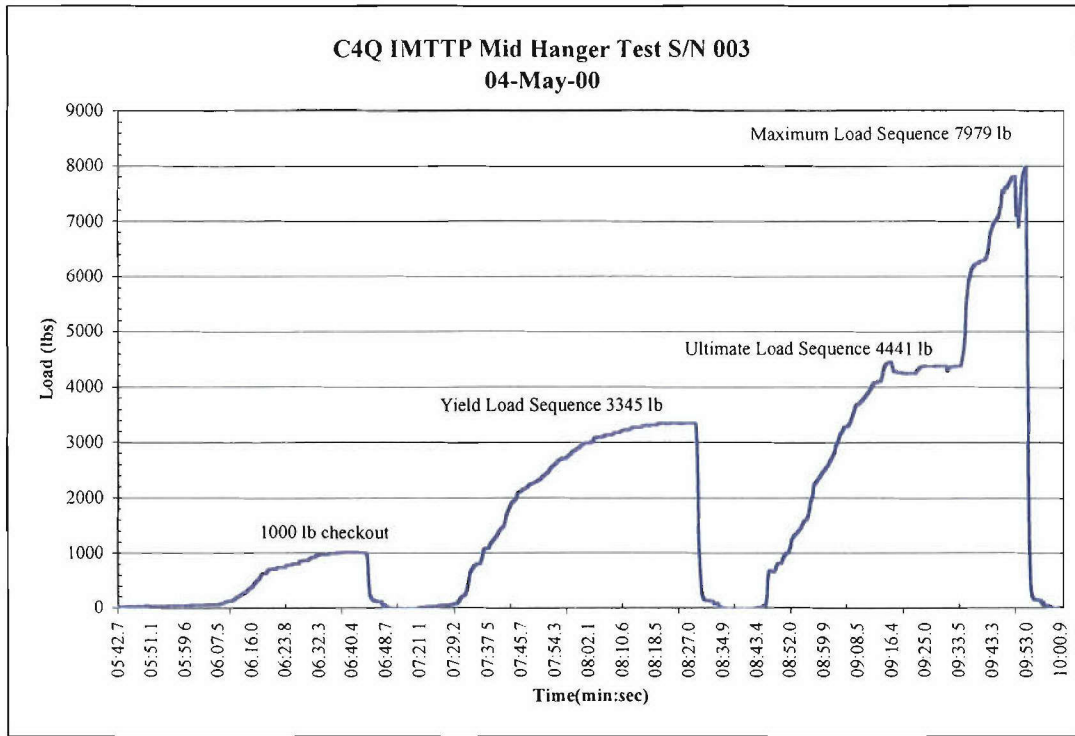

FIGURE H-3. Middle Hanger Test Load History (No Release Agent).

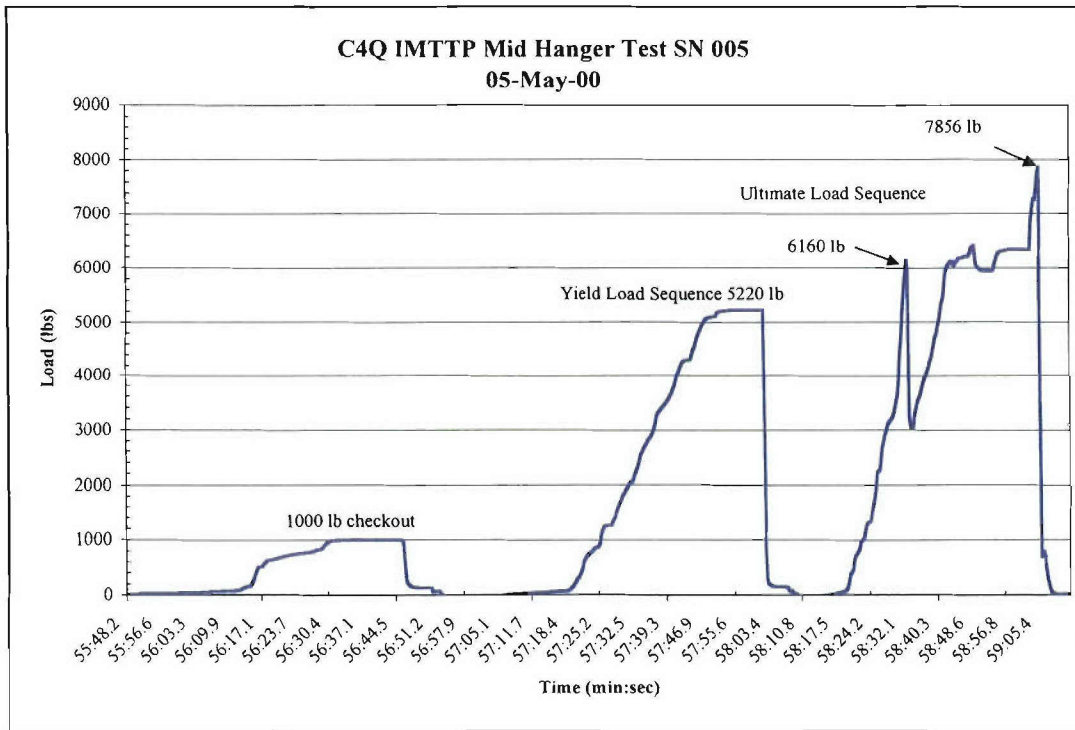

FIGURE H-4. Middle Hanger Test Load History (With Release Agent).

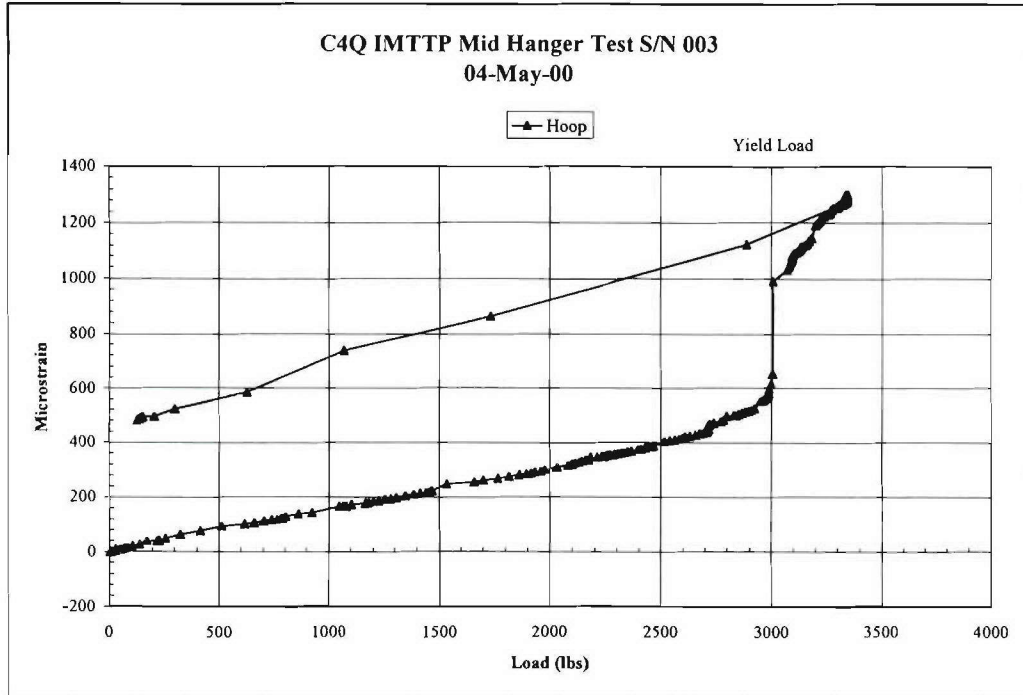

FIGURE H-5. Yield Test Hoop Strain Data History (No Release).

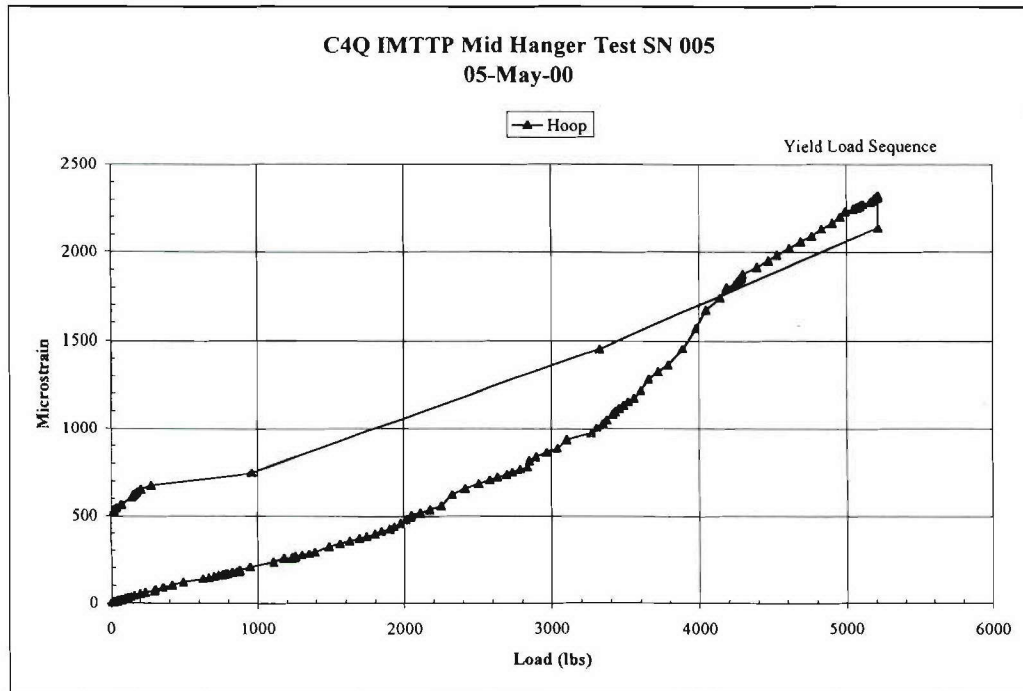

FIGURE H-6. Yield Test Hoop Strain Data (With Release).

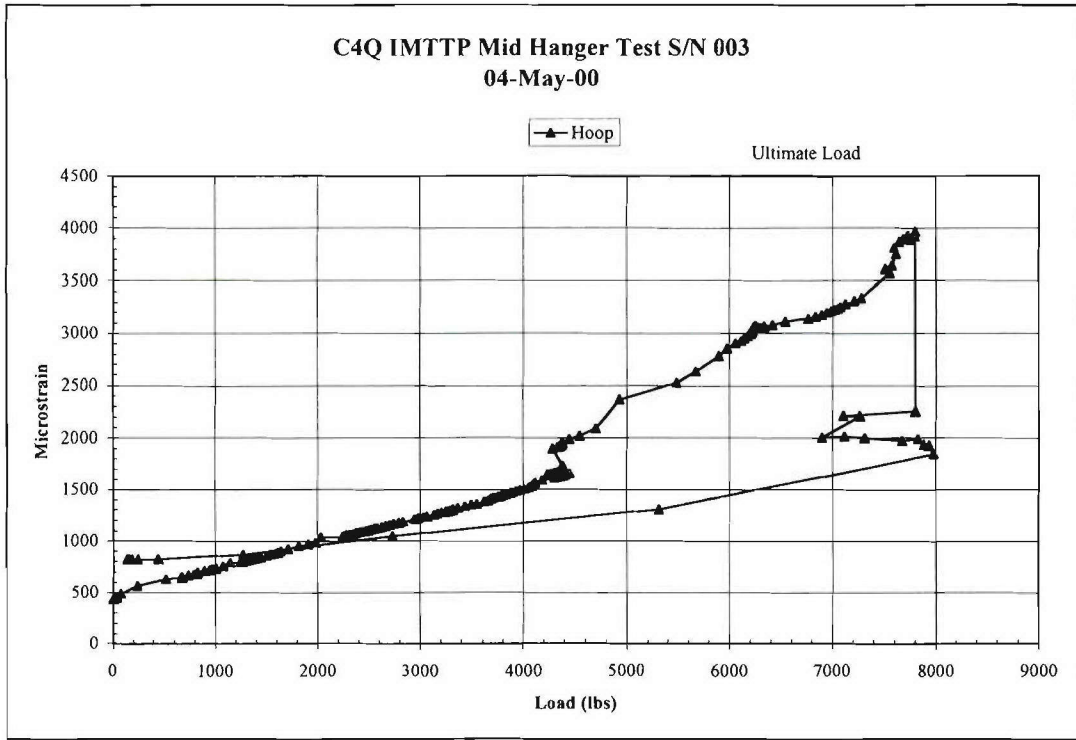

FIGURE H-7. Ultimate Test Hoop Strain Data (No Release).

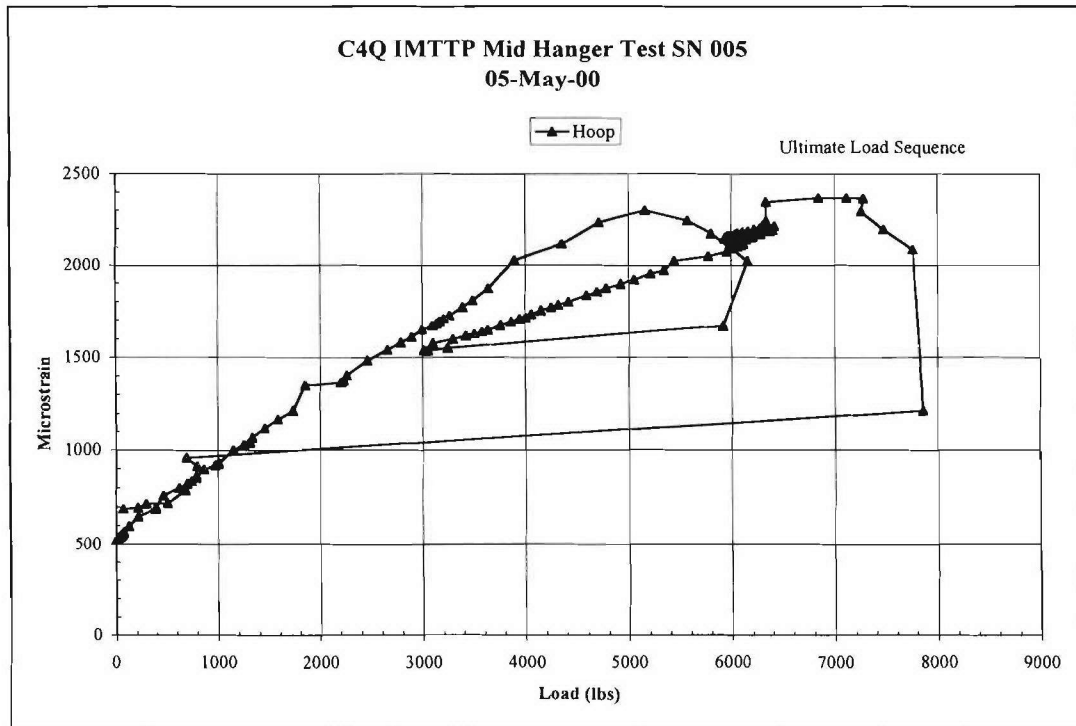

FIGURE H-8. Ultimate Test Hoop Strain Data (With Release).

Both tubes failed in a similar manner. The failures were inside the composite tube, along the edge of the wound-in hanger pad, as the tube distorted inwards from the applied moment. The first specimen was unloaded at this point. The loading on the second specimen was continued until a further tensile failure occurred in the outer fibers on the other side of the hanger pad from the initial failure. The failures indicate that a fairly simple change in the design of the edge of the wound-in hanger pad will improve the performance of this component. This test will be repeated with the redesign. Figures H-9 through H-12 show the failures.

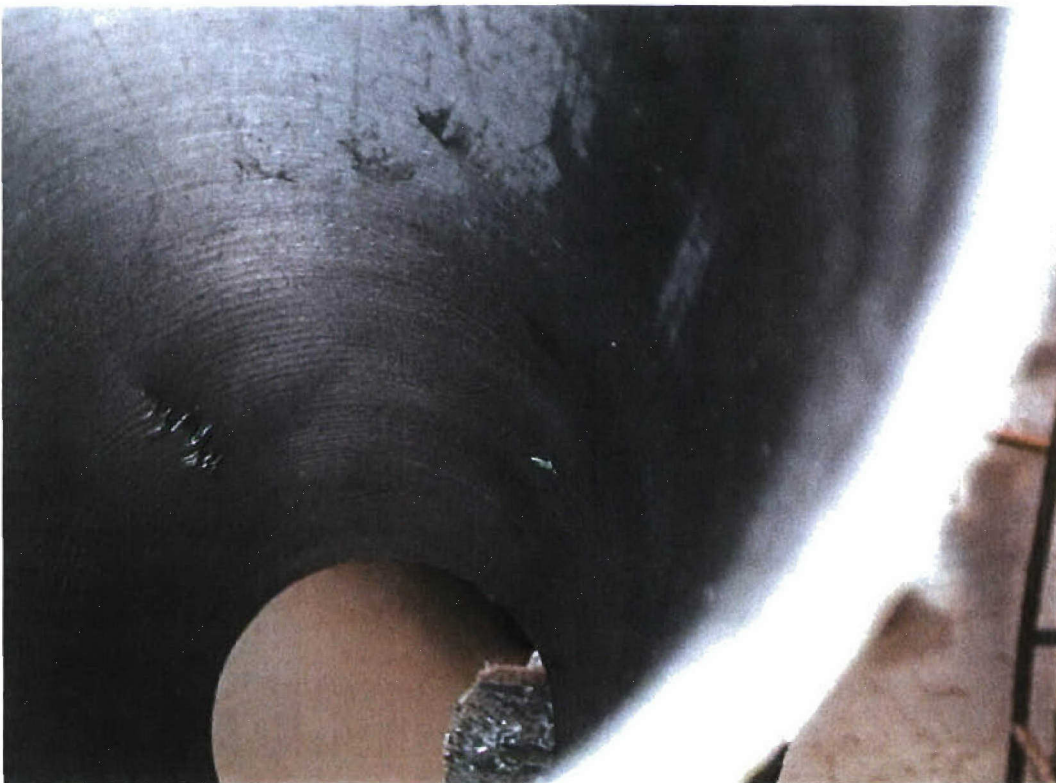

FIGURE H-9. Middle Hanger Failure (No Release), Inside View.

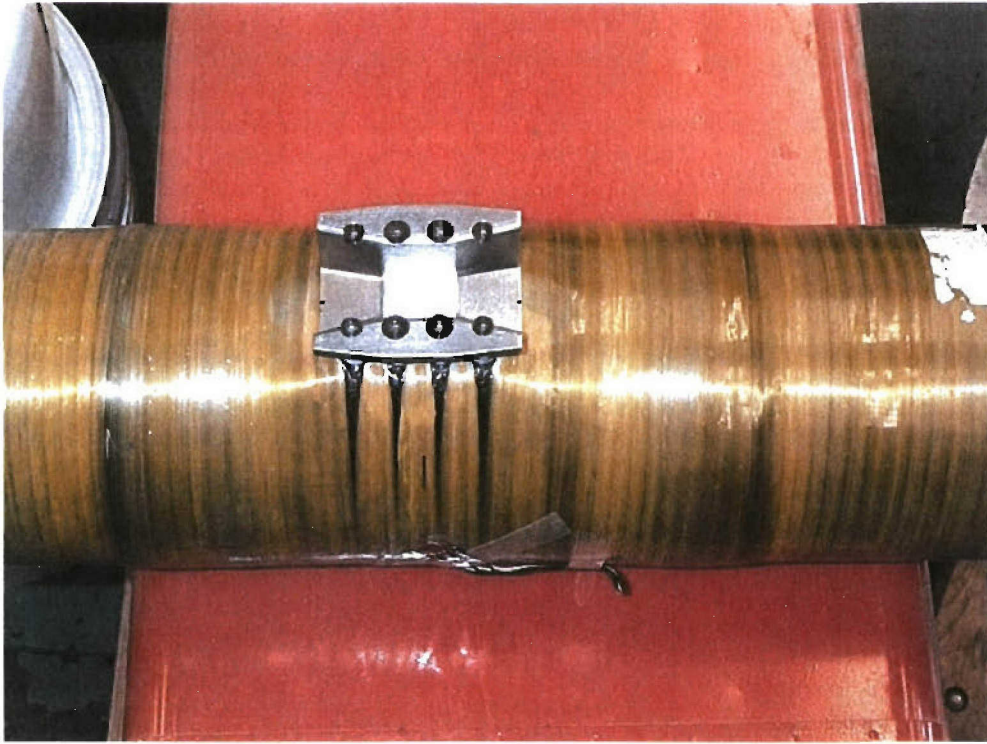

FIGURE H-10. Middle Hanger Failure (No Release), Outside View.



FIGURE H-11. Middle Hanger Failure (With Release), Inside View.



FIGURE H-12. Middle Hanger Failure (With Release), Outside View.

SUMMARY

SPECIMEN WITHOUT RELEASE ON HANGER PAD

Based on the required load of 6800 pounds (including composite knockdowns) and the maximum tested load of 7800 pounds, the ultimate M.S. for the hanger is determined via Equation H-5.

$$M.S. = \frac{7800}{6800} - 1 = +0.15 \quad (H-5)$$

SPECIMEN WITH RELEASE ON HANGER PAD

Based on the maximum load before the first major failure and shift in the strain at 6160 pounds, the M.S. for the hanger is determined via Equation H-6.

$$M.S. = \frac{6160}{6800} - 1 = -0.09 \quad (H-6)$$

With the hanger pad completely released from the composite, neither the yield nor ultimate load could pass the requirements.

Overall, the C⁴Q composite blue tube failed the middle hanger load test due to strain redistribution at yield loads and marginally passed the ultimate loads test unless the hanger pad was chemically released from the composite tube. The failure mode leads to a relatively simple improvement in the wound-in pad design. The middle hanger will be re-tested with the new design.

Appendix I
COMPOSITE CASE CAPTIVE CARRY QUALIFICATION (C⁴Q)
BLUE TUBE MODIFIED MIDDLE HANGER TEST PLAN

(This page intentionally left blank.)

1.0 INTRODUCTION

This test plan describes the requirements of the Insensitive Munitions Technology Transition Program (IMTTP) Composite Case Captive Carry Qualification (C⁴Q) composite structural verification tests. The middle hanger test is an ultimate load test of the middle hanger to missile body joint.

2.0 OBJECTIVE

The primary purpose of this test is to verify that design requirements are met. This test plan provides the overall instructions for performing the test.

3.0 TEST DESCRIPTION

The test requirements, as defined by the loads given in the design criteria, will be demonstrated via yield and ultimate testing.

Yield testing consists of applying limit loading (2899-pound side load to the hanger) times a 1.15 factor for a total applied load of 3333 pounds. This is increased to account for the composite knockdowns (times 1.25 for impact and times 1.25 for hygrothermal) for a 5200-pound yield load.

Ultimate testing consists of applying limit load times a 1.5 factor for ultimate testing, resulting in a total applied load of 4348 pounds. This is increased to account for the composite knockdowns (times 1.25 for impact and times 1.25 for hygrothermal) for a 6800-pound ultimate load.

The success criteria are as follows. Yield testing shall be considered successful if the case and hanger withstand yield load without anomalous behavior that would be indicative of their inability to perform their intended use. This shall be determined by inspection (visual and dimensional) and comparison of data (strains and deflections) with predicted values.

Ultimate load testing shall be considered successful if the case and hanger fail in the predicted manner at 1.5 or higher load factor.

3.1 TEST ARTICLE DESCRIPTION

The test article consists of the middle part of an IMTTP C⁴Q composite tube (Serial Number 006), shown here in Figure I-1. (Note: All of the figures are provided at the end of this document.) The test article consists of a segment of the composite tube with the middle hanger attached. The segment is 24 inches in length.

The smaller (3/16-32) mid-body hanger bolts (476200D130-2) are installed wet with epoxy and torqued to 100 in-lb. The larger (1/4-28) mid-body hanger bolts (476200D130-1) are also installed wet with epoxy. They are torqued to 250 in-lb.

3.2 TEST FACILITIES

The test facility is located at the Code 476300D environmental laboratory. Hanger tests will be done on the static frame tester.

The test equipment for the bending moment test consists of a hydraulic load jack, load cell, strain gages, and signal conditioning and recording equipment.

The test fixturing to be used for the hanger test will include a hanger tie-down block (with launcher-like interface), a loading beam, and connecting straps. The layout of the test fixture is shown in Figure I-2.

4.0 INSTRUMENTATION AND DATA REQUIREMENTS

The instrumentation requirements for these tests will be the same for both proof (yield) and ultimate tests. All strain gages are 45-degree rectangular rosette (MM CEA-06-125 UR-350) gages. The placement of the instrumentation is shown in Figure I-3.

The accuracy requirements for the instrumentation through the data recording system shall be as provided in Table I-1.

TABLE I-1. Accuracy Requirements for Instrumentation.

Strain Gages	$\pm 0.08\%$ strain
Load Cell	± 10.0 lb
Displacement Potentiometers	± 0.01 inch
Thermocouples	$\pm 5^\circ\text{F}$

The test data shall be reduced and plotted at five samples per second. Two copies of all printouts and plots are required. The digital listings (printouts) will have the strain and displacement as a function of load. Digital plotting will be in the format provided in Table I-2.

TABLE I-2. Digital Plotting Format.

Instrumentation	Abscissa	Ordinate
Load (shear load) cell	Time, seconds	0 to 20,000 lb
Strain gages (SG1-SG12)	0 to 20,000 lb	-3.50 to 3.50%

5.0 TEST PROCEDURE AND SETUP

5.1 MAXIMUM HANGER LOAD TESTS

Prior to the tests, the test director will define selected priority data, which will be immediately processed and reviewed prior to proceeding with the testing.

The general test procedures are as follows.

1. Attach the load actuator stinger to the loading beam.
2. Place article into the static test frame.
3. Attach the forward hanger to the hanger tie-down block.
4. Connect all instrumentation.
5. Take pretest photographs of the test setup.
6. Slowly raise the load to 1000 pounds and then lower the load back to zero. Observe strain gage and displacement readings. Verify all instrumentation is operating properly.
7. Once correct instrumentation operation has been confirmed, start recording data and begin to raise the load in accordance with Figure I-4.
8. Turn off instrumentation and disconnect all lead wiring and fixtures.
9. Note all anomalies during and after the testing.
10. Take post-test photographs of the test setup.
11. Remove test article (see Sections 5.1.1 and 5.1.2).

5.1.1 Test Precautions

The composite tube specimen will be placed in an isolated area during the test. Hazardous flying debris is expected during the ultimate test and all precautions shall be taken to avoid exposure to the debris. Extreme care should be taken in handling the remains of the case after the test is completed. All the bending moment tests must comply with all Code 476300D safety requirements.

5.1.2 Test Article Disposition

The composite tube and hanger joint will be post inspected after proof and ultimate tests by Code 476J00D personnel. The tube will be delivered to Code 476J00D for sectioning into coupons and cylindrical test articles after the ultimate test.

6.0 SUMMARY

Following this hanger load test, a summarized report shall be drafted describing the test and the results. Pertinent diagrams and graphs shall be included.

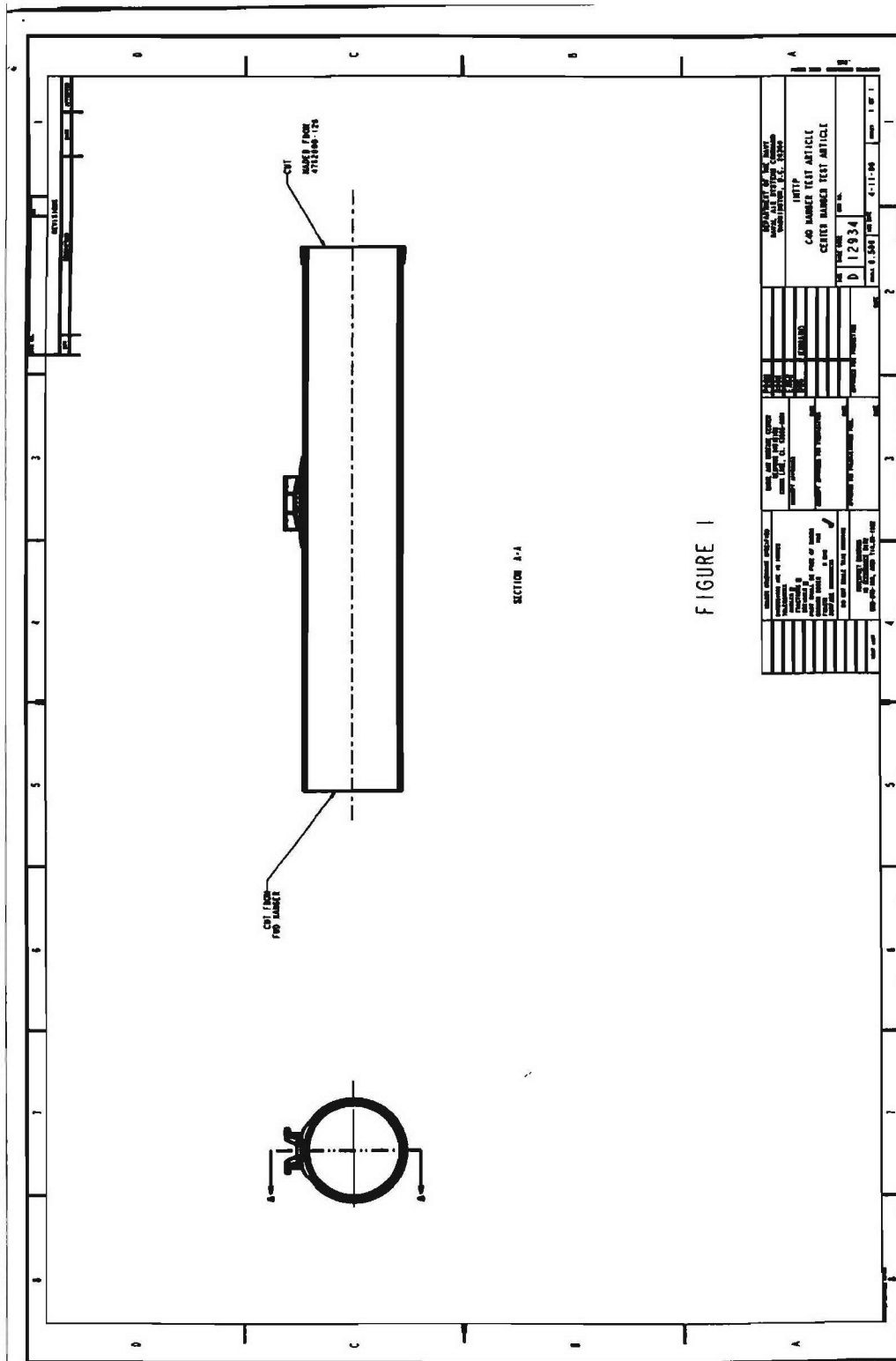

FIGURE I-1. Middle Part of IMTTP C⁴Q Composite Tube.

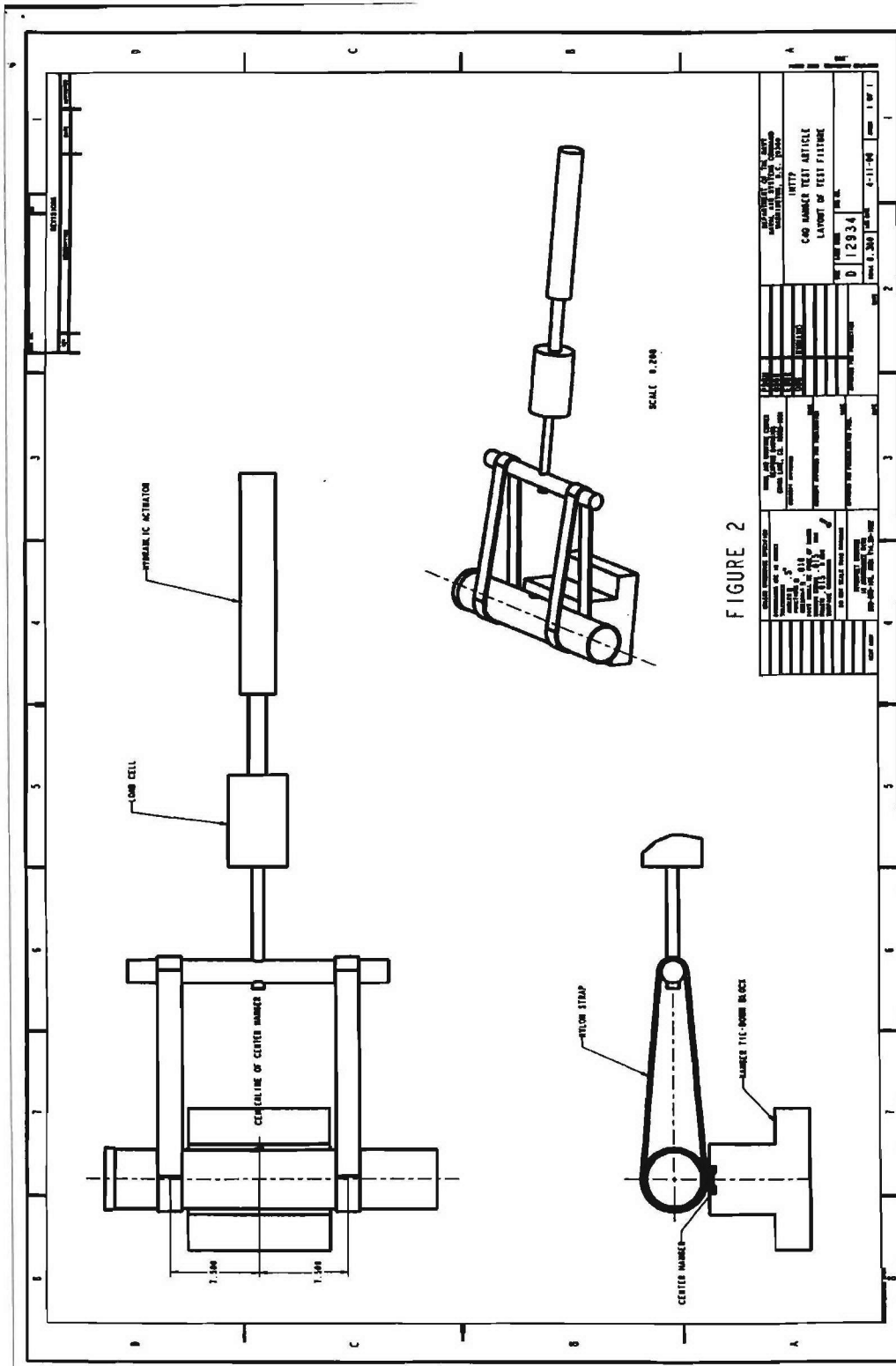

FIGURE I-2. Text Fixture Layout.

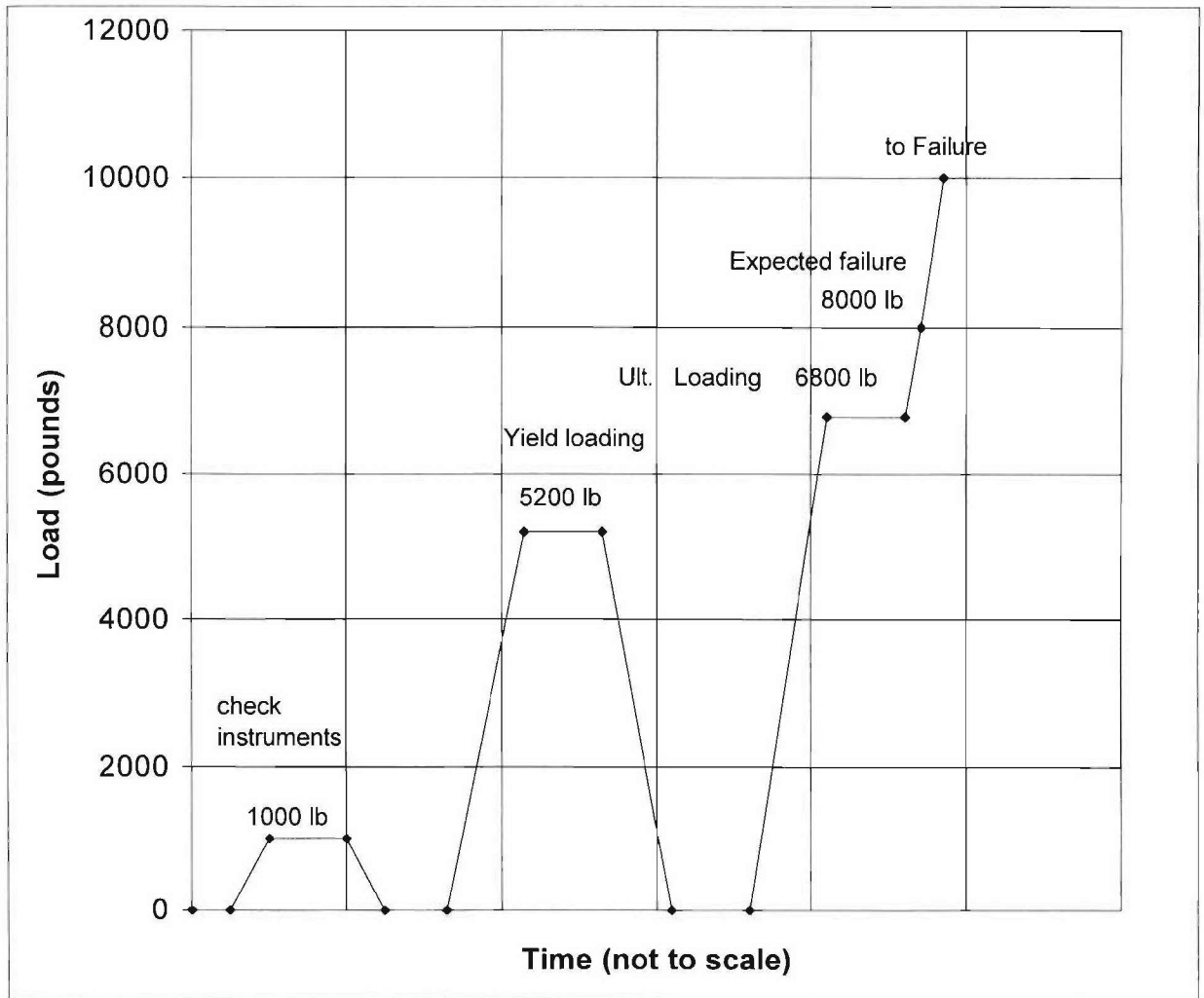

FIGURE I-4. Load Schedule.

Appendix J
COMPOSITE CASE CAPTIVE CARRY QUALIFICATION (C⁴Q)
BLUE TUBE MODIFIED MIDDLE HANGER TEST REPORT

(This page intentionally left blank.)

CONTENTS

Test Description	J-5
Introduction.....	J-5
Test Specimen.....	J-5
Loading Condition	J-5
Analysis of Loading	J-6
Middle Hanger Loading Development	J-6
Test Results	J-7
Yield Test.....	J-7
Ultimate Test.....	J-7
Summary.....	J-13
Specimen Without Released Hanger Pad	J-13
Specimen With Released Hanger Pad.....	J-13

Figures:

J-1. All-up-round (AUR) Structural Layout.....	J-5
J-2. Middle Hanger Loading Fixture	J-6
J-3. Middle Hanger Test Load History (No Release Agent)	J-8
J-4. Middle Hanger Test Load History (With Release Agent)	J-8
J-5. Yield Test Hoop Strain Data History (No Release).....	J-9
J-6. Yield Test Hoop Strain Data History (With Release).....	J-9
J-7. Ultimate Test Hoop Strain Data (No Release)	J-10
J-8. Ultimate Test Hoop Strain Data (With Release).....	J-10
J-9. Middle Hanger Failure (No Release), Inside View.....	J-11
J-10. Middle Hanger Failure (No Release), Outside View	J-11
J-11. Middle Hanger Failure (With Release), Inside View	J-12
J-12. Middle Hanger Failure (With Release), Outside View.....	J-12

(This page intentionally left blank.)

TEST DESCRIPTION

INTRODUCTION

The Composite Case Captive Carry Qualification (C⁴Q) blue tube middle hanger test is a full-scale structural test of the composite blue tube. The goal was to simulate the worst-case captive carriage load on the middle hanger. This test, in combination with other testing, is intended to demonstrate the structural adequacy of the C⁴Q blue tube design. This test is performed on a full-scale specimen at room temperature. The hanger loads are worst case for station 1 or 9 (wing tip) of the F/A-18C/D. The test showed a margin of safety (M.S.) of +0.19 for the middle hanger. This was with a 1.5 factor of safety for ultimate load and an additional 1.25 factor to cover the hot/wet knockdown and 1.25 to cover the impact damage knockdown. The same test was performed for a middle hanger with a deliberate disbond between the metal and composite. It showed a margin of +0.16 for ultimate with the same factors as before.

TEST SPECIMEN

For reference, Figure J-1 shows the basic structural layout of the CATM-9M with the C⁴Q hardware. The test article consists of the middle segment of the composite tube with the middle hanger attached. The segment is 24 inches in length (cut 12 inches on either side of the middle hanger). The smaller (3/16-32) hanger bolts are installed wet with epoxy at a torque of 100 in-lb. The larger (1/4-20) bolts are installed wet with epoxy at a torque of 250 in-lb. There were two specimens tested. The first was manufactured according to the Process Specification 0032 and the second included a flash tape on the wound-in hanger mounting pad to simulate a disbonded pad.

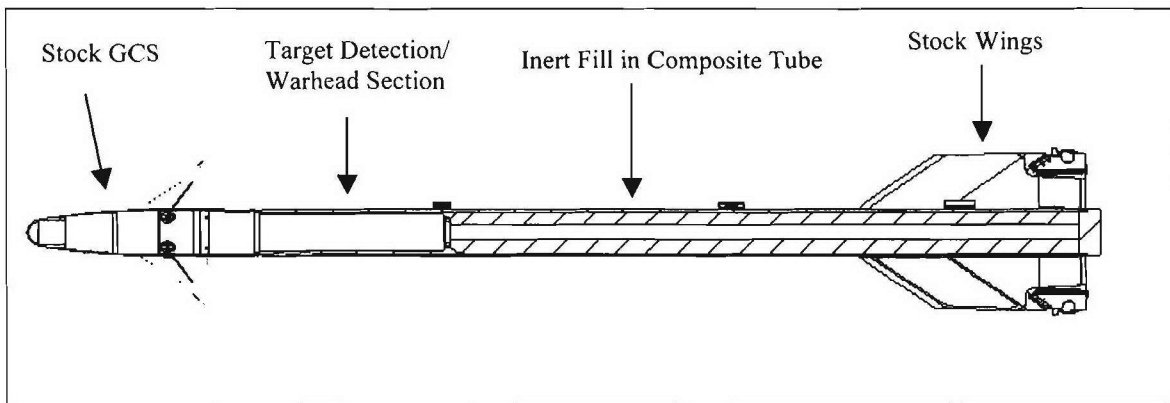

FIGURE J-1. All-up-round (AUR) Structural Layout.

LOADING CONDITION

The specimens were loaded to simulate the load direction and magnitude of the middle hanger on the wing tip stations during the worst-case maneuver (the Mk 84 bomb release). The loading was raised to

yield level and returned to zero in order to confirm that no permanent deformation occurred. The loading was then raised until it produced a failure. The specimen, fixtures, and loading sequence can be seen in detail in the test plan (Appendix I) and in Figure J-2.

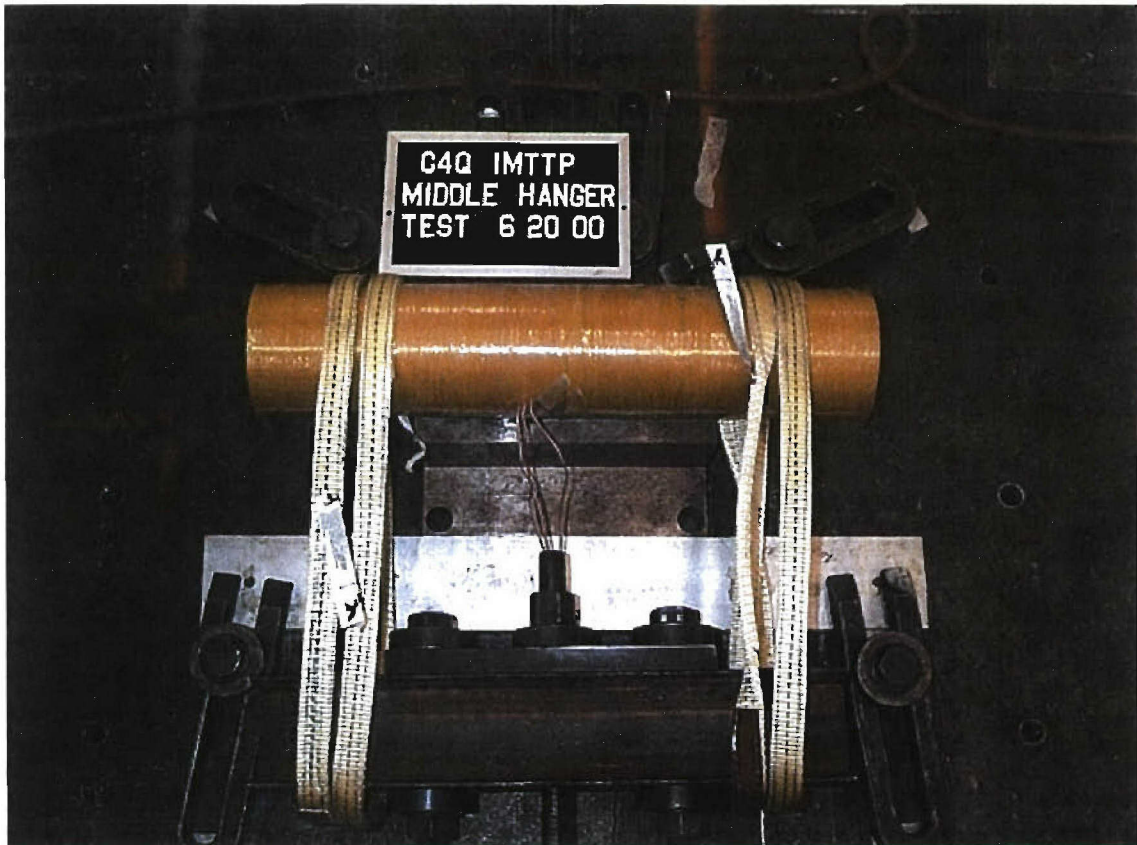

FIGURE J-2. Middle Hanger Loading Fixture.

ANALYSIS OF LOADING

MIDDLE HANGER LOADING DEVELOPMENT

The development of the middle hanger loading value is based on the assumption that the composite material will fail before the metal hanger or the hanger attachment bolts. Therefore, the load requirement was exaggerated to cover the reduced composite material properties due to hot/wet conditions and impact damage by factors of 1.25 and 1.25. This increased load value is used for the M.S. calculations. The magnitude of the load corresponds to the reactions in the finite element loads model at the middle hanger due to the Mk 84 release condition (worst-case limit load). This is a limit load in the missile Y direction of 2899 pounds.

Equations J-1 through J-4 apply.

$$\text{Yield Load} = 2900 \times 1.15 = 3330 \text{ pounds} \quad (\text{J-1})$$

$$\text{Yield With Knockdowns} = 2900 \times 1.15 \times 1.25 \times 1.25 = 5210 \text{ pounds} \quad (\text{J-2})$$

$$\text{Ultimate Load} = 2900 \times 1.50 = 4350 \text{ pounds} \quad (\text{J-3})$$

$$\text{Ultimate With Knockdowns} = 2900 \times 1.5 \times 1.25 \times 1.25 = 6800 \text{ pounds} \quad (\text{J-4})$$

TEST RESULTS

The test plan is included in Appendix I. It contains the procedures and figures needed to execute the test. This test was performed on 20 June 2000. All fixtures and instrumentation performed as expected. The test was performed in two stages. The first stage was to increase the load to the yield load and back down to zero. The second stage was to increase the load to ultimate and on up to the end of test limit. Figure J-3 shows the actual applied load history for the first test (no release agent) and Figure J-4 shows it for the specimen with release agent.

YIELD TEST

Figures J-5 and J-6 show the hoop strain data for the yield test. This was the dominant strain direction and provides the best indication of the structural response. Visually, neither specimen showed signs of damage. There is some residual strain, but it is expected due to a slight residual load and the settling in of the test fixture. The inadvertent release of load at yield and then return to yield level during the "with release" test show that the strain tracks its previous path and there is no permanent damage at yield.

ULTIMATE TEST

The next stage in the test was to increase the load on the hangers until failure. The strain data are presented in Figures J-7 and J-8.

Both tubes failed in a similar manner. The failures were initiated inside the composite tube, along the edge of the wound in hanger pad, and then failed in the fasteners. Both failures were comfortably above the ultimate load. In addition, there was insignificant difference between the regularly manufactured article and the test article with a built-in disbond between the wound-in pad and the composite case. This confirms the mechanically locked-in design functions as expected, despite a bond failure. Figures J-9 through J-12 show the failures.

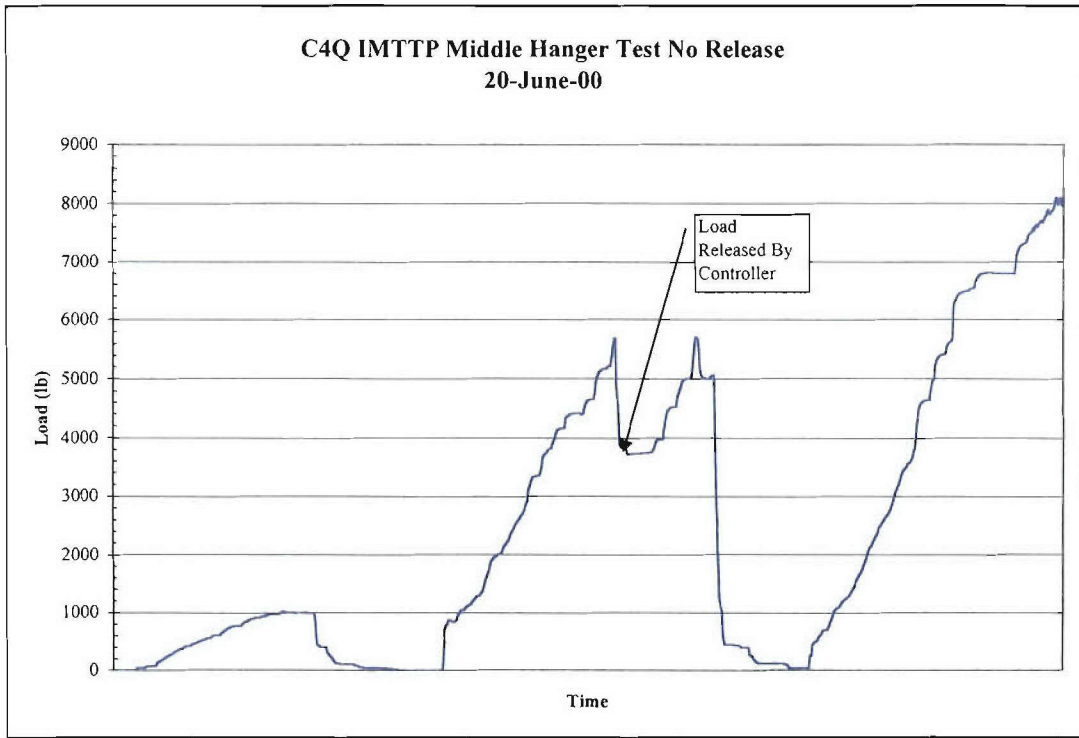

FIGURE J-3. Middle Hanger Test Load History (No Release Agent).

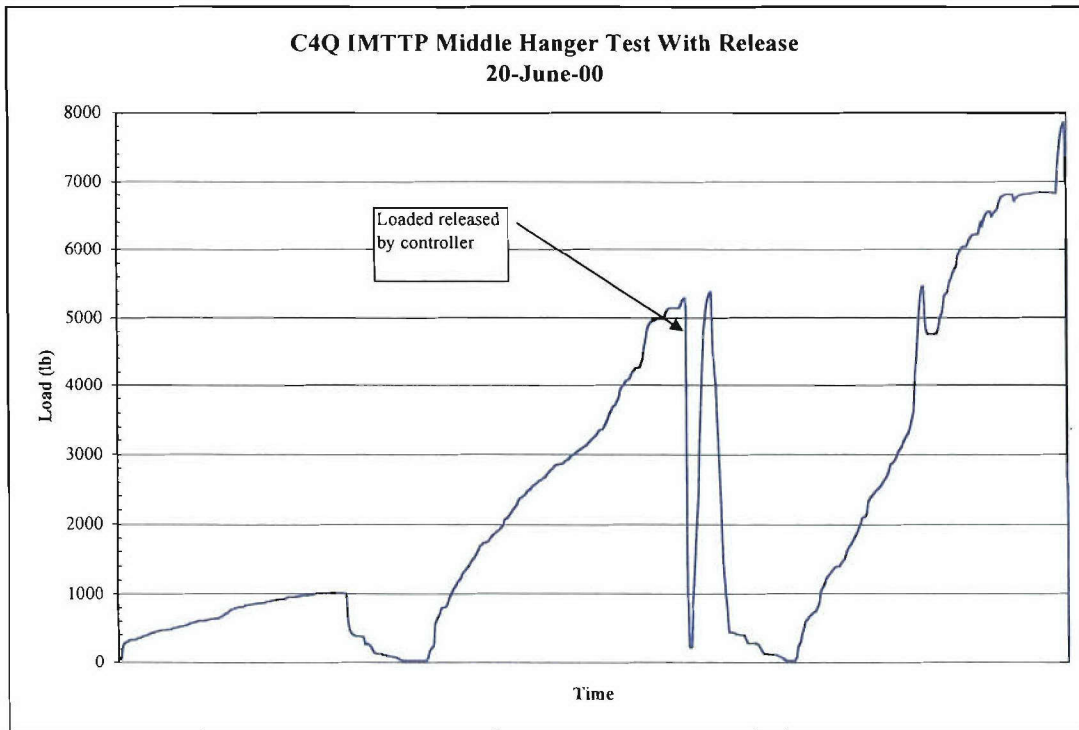

FIGURE J-4. Middle Hanger Test Load History (With Release Agent).

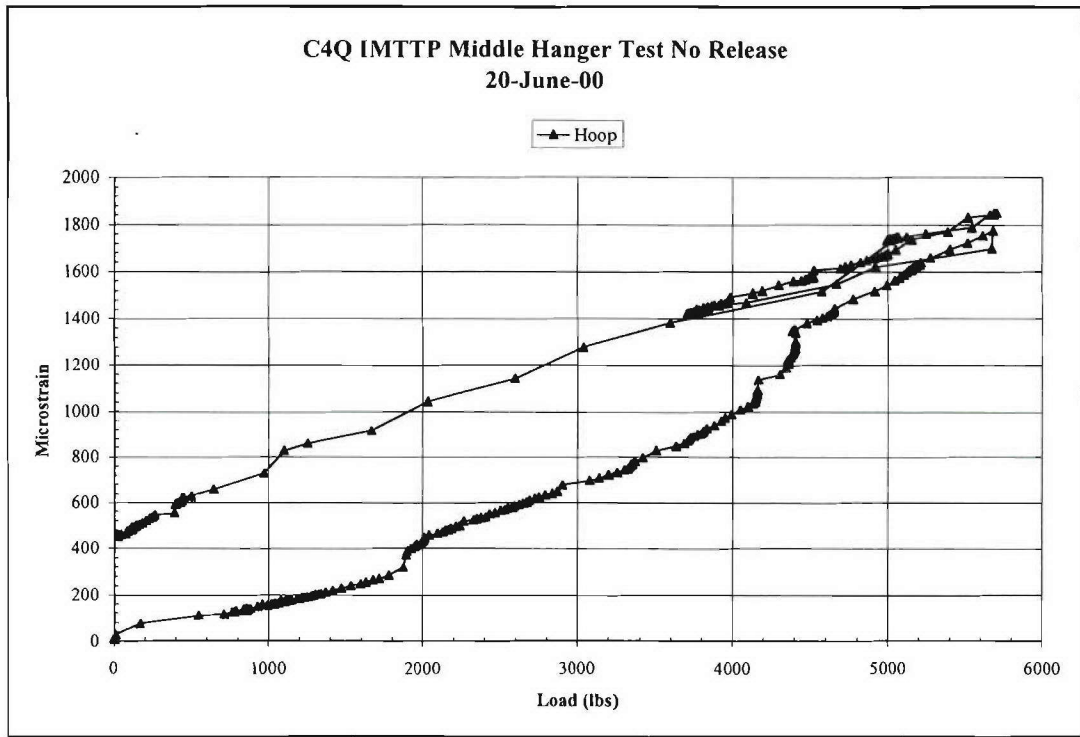

FIGURE J-5. Yield Test Hoop Strain Data History (No Release).

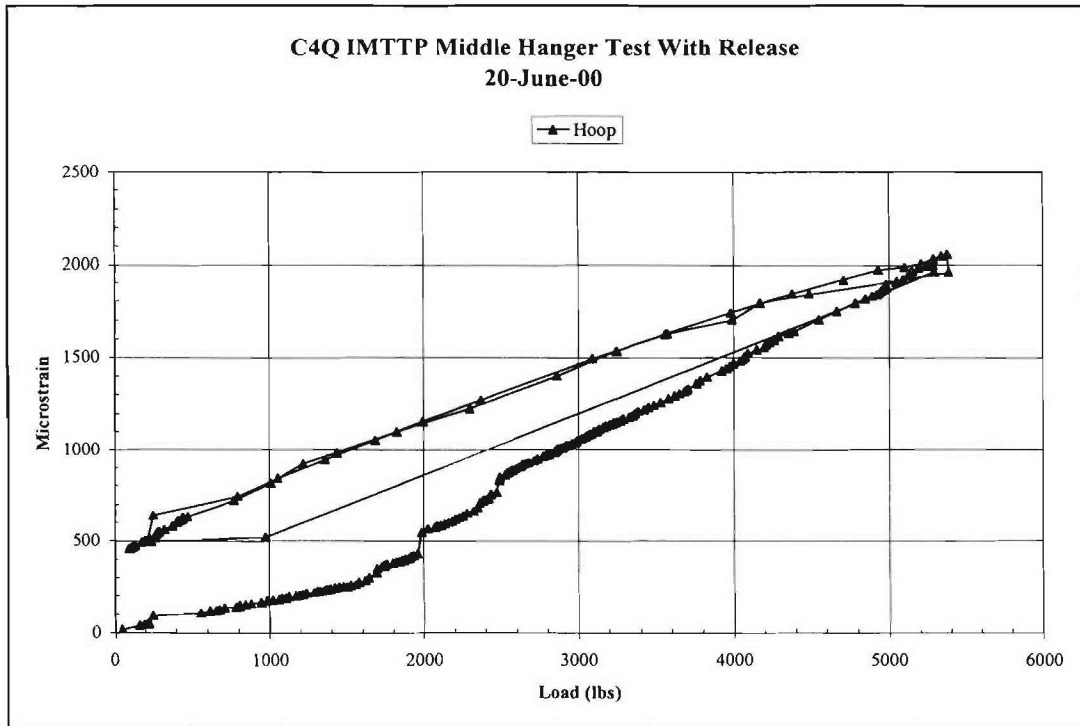

FIGURE J-6. Yield Test Hoop Strain Data (With Release).

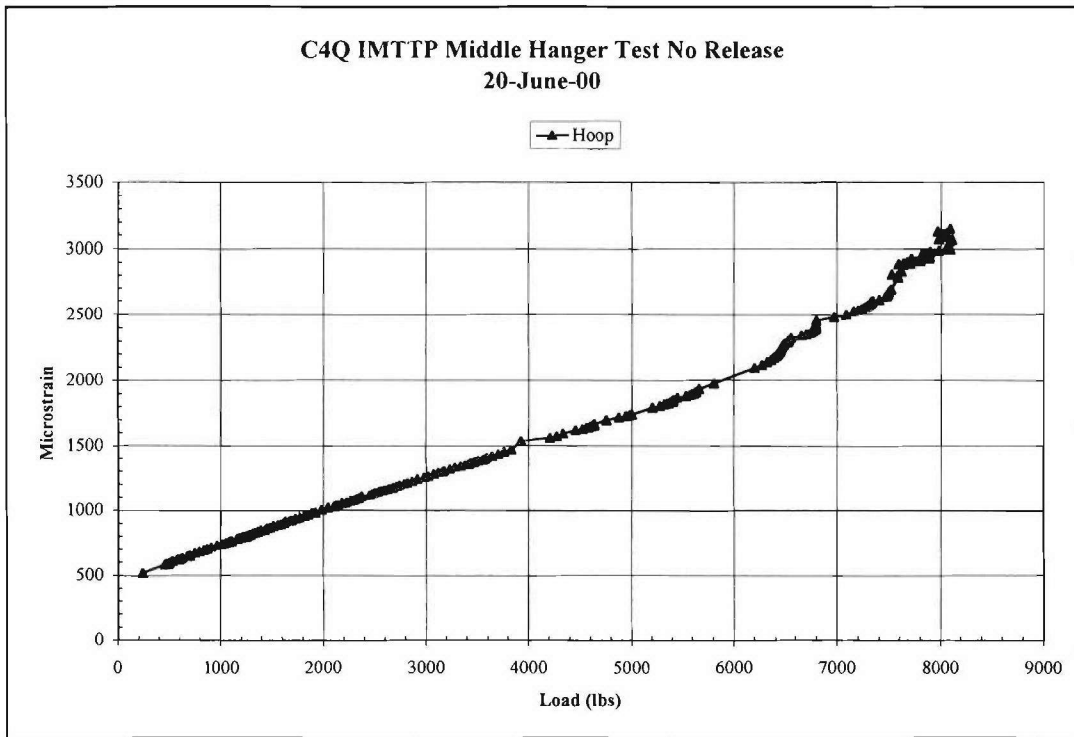

FIGURE J-7. Ultimate Test Hoop Strain Data (No Release).

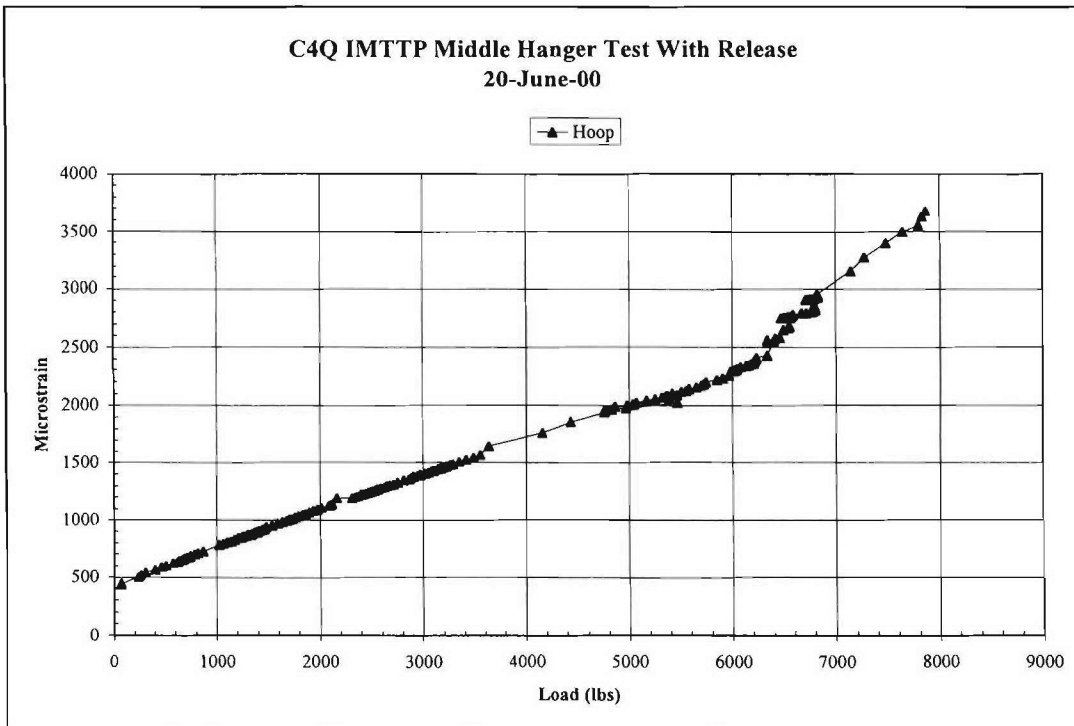

FIGURE J-8. Ultimate Test Hoop Strain Data (With Release).



FIGURE J-9. Middle Hanger Failure (No Release), Inside View.

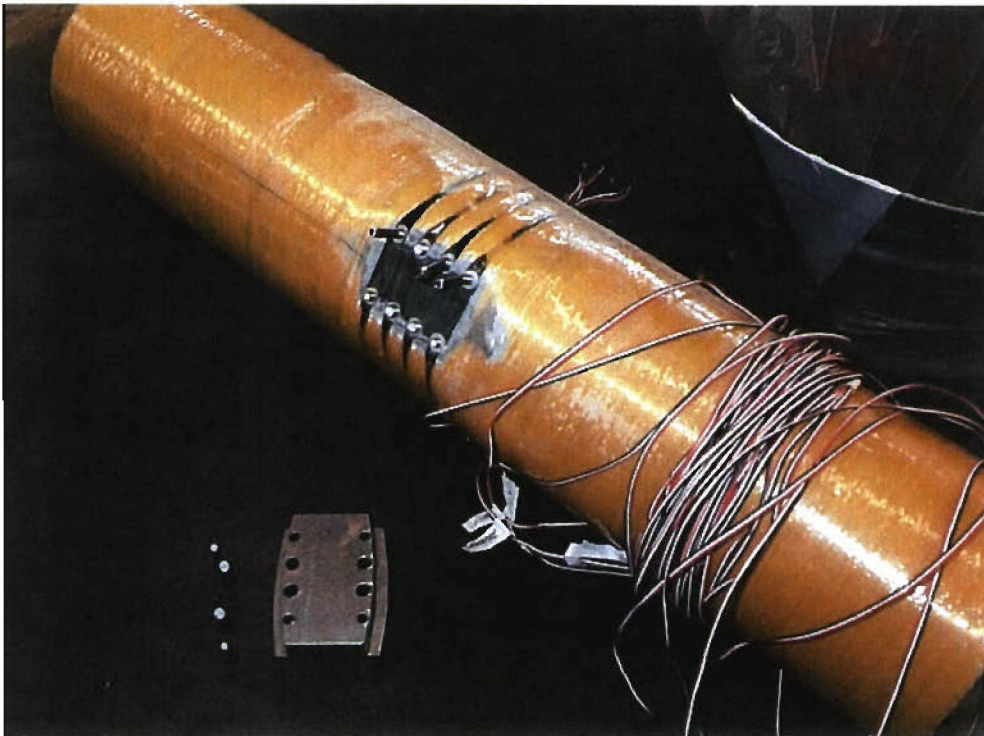

FIGURE J-10. Middle Hanger Failure (No Release), Outside View.



FIGURE J-11. Middle Hanger Failure (With Release), Inside View.

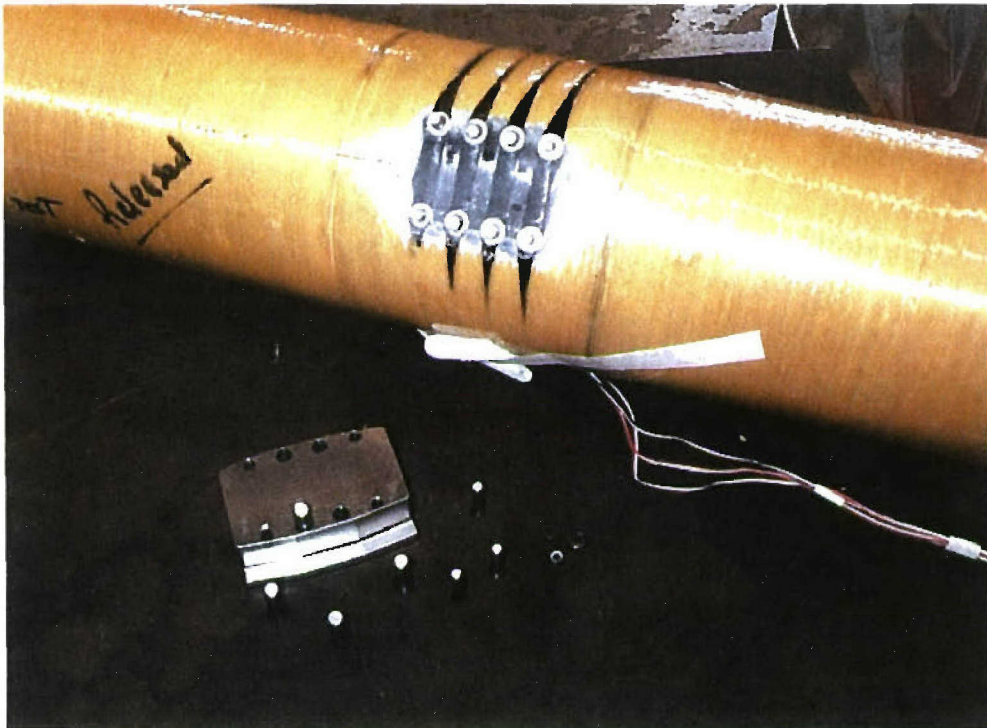

FIGURE J-12. Middle Hanger Failure (With Release), Outside View.

SUMMARY**SPECIMEN WITHOUT RELEASED HANGER PAD**

Based on the required load of 6800 pounds (including composite knockdowns) and the maximum tested load of 8109 pounds, the ultimate M.S. for the hanger is determined via Equation J-5.

$$M.S. = \frac{8109}{6800} - 1 = +0.19 \quad (J-5)$$

SPECIMEN WITH RELEASED HANGER PAD

Based on the maximum tested load of 7860 pounds, the M.S. for the hanger is determined via Equation J-6.

$$M.S. = \frac{7860}{6800} - 1 = +0.16 \quad (J-6)$$

With the hanger pad manufactured per the process specification or completely released from the composite, the modified middle hanger passed both the yield and ultimate tests.

Appendix K
COMPOSITE CASE CAPTIVE CARRY QUALIFICATION (C⁴Q)
BLUE TUBE AFT HANGER TEST PLAN

(This page intentionally left blank.)

1.0 INTRODUCTION

This test plan describes the requirements of the Insensitive Munitions Technology Transition Program (IMTTP) Composite Case Captive Carry Qualification (C⁴Q) composite structural verification tests. The aft hanger test is an ultimate load test of the aft hanger to missile body joint.

2.0 OBJECTIVE

The primary purpose of this test is to verify that design requirements are met. This test plan provides the overall instructions for performing the test.

3.0 TEST DESCRIPTION

The test requirements, as defined by the loads given in the design criteria, will be demonstrated via yield and ultimate testing.

Yield testing consists of applying limit loading (1348-pound side load to the hanger) times a 1.15 factor for a total applied load of 1550 pounds.

Ultimate testing consists of applying limit load times a 1.5 factor for ultimate testing, resulting in a total applied load of 2022 pounds.

The success criteria are as follows. Yield testing shall be considered successful if the case and hanger withstand yield load without anomalous behavior that would be indicative of their inability to perform their intended use. This shall be determined by inspection (visual and dimensional) and comparison of data (strains and deflections) with predicted values.

Ultimate load testing shall be considered successful if the case and hanger fail in the predicted manner at 1.5 or higher load factor or once a load factor of 3 (4044 pounds) has been reached.

3.1 TEST ARTICLE DESCRIPTION

The test article consists of the aft part of an IMTTP C⁴Q composite tube (Serial Number 003), shown here in Figure K-1. (Note: All of the figures are provided at the end of this document.) The test article consists of a segment of the composite tube with the aft hanger attached. The segment is 26 inches in length (forward edge as cut for the middle hanger specimen and the aft edge is the "as-manufactured" end of the tube).

The 1/4-28 bolts are installed wet with epoxy and torqued to 240 in-lb.

3.2 TEST FACILITIES

The test facility is located at the Code 476300D environmental laboratory. Hanger tests will be done on the static frame tester.

The test equipment for the bending moment test consists of a hydraulic load jack, load cell, strain gages, and signal conditioning and recording equipment.

The test fixturing to be used for the hanger test will include a hanger tie-down block (with launcher-like interface), a loading beam, and connecting straps. The layout of the test fixture is shown in Figure K-2.

4.0 INSTRUMENTATION AND DATA REQUIREMENTS

The instrumentation requirements for these tests will be the same for both proof (yield) and ultimate tests. All strain gages are 45-degree rectangular rosette (MM CEA-06-125 UR-350) gages. The placement of the instrumentation is shown in Figure K-3.

The accuracy requirements for the instrumentation through the data recording system shall be as provided in Table K-1.

TABLE K-1. Accuracy Requirements for Instrumentation.

Strain Gages	$\pm 0.08\%$ strain
Load Cell	± 10.0 lb
Displacement Potentiometers	± 0.01 inch
Thermocouples	$\pm 5^\circ\text{F}$

The test data shall be reduced and plotted at five samples per second. Two copies of all printouts and plots are required. The digital listings (printouts) will have the strain and displacement as a function of load. Digital plotting will be in the format provided in Table K-2.

TABLE K-2. Digital Plotting Format.

Instrumentation	Abscissa	Ordinate
Load (shear load) cell	Time, seconds	0 to 20,000 lb
Strain gages (SG1-SG12)	0 to 20,000 lb	-3.50 to 3.50%

5.0 TEST PROCEDURE AND SETUP

5.1 MAXIMUM HANGER LOAD TESTS

Prior to the tests, the test director will define selected priority data, which will be immediately processed and reviewed prior to proceeding with the testing.

The general test procedures are as follows.

1. Attach the load actuator stinger to the loading beam.
2. Place article into the static test frame.
3. Attach the forward hanger to the hanger tie-down block.
4. Connect all instrumentation.
5. Take pretest photographs of the test setup.
6. Slowly raise the load to 1000 pounds and then lower the load back to zero. Observe strain gage and displacement readings. Verify all instrumentation is operating properly.
7. Once correct instrumentation operation has been confirmed, start recording data and begin to raise the load in accordance with Figure K-4.
8. Turn off instrumentation and disconnect all lead wiring and fixtures.
9. Note all anomalies during and after the testing.
10. Take post-test photographs of the test setup.
11. Remove test article (see Sections 5.1.1 and 5.1.2).

5.1.1 Test Precautions

The composite tube specimen will be placed in an isolated area during the test. Hazardous flying debris is expected during the ultimate test and all precautions shall be taken to avoid exposure to the debris. Extreme care should be taken in handling the remains of the case after the test is completed. All the bending moment tests must comply with all Code 476300D safety requirements.

5.1.2 Test Article Disposition

The composite tube with inert fill will be post inspected after proof (yield) and ultimate tests by Code 476J00D personnel. The tube will be delivered to Code 476J00D for sectioning into coupons and after the ultimate test.

6.0 SUMMARY

Following this hanger load test, a summarized report shall be drafted describing the test and the results. Pertinent diagrams and graphs shall be included.

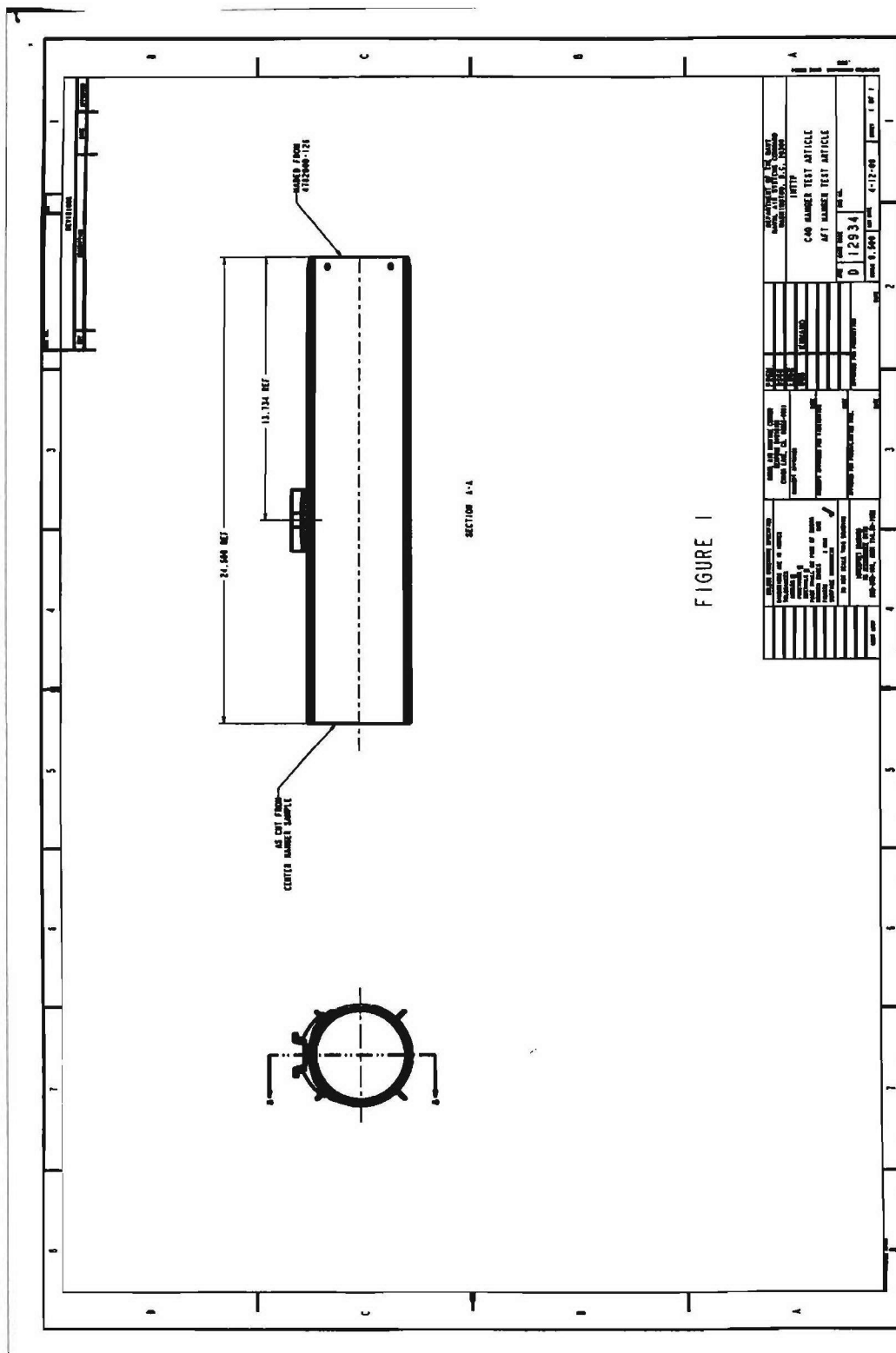

FIGURE K-1. Aft Part of IMTTP C⁴Q Composite Tube.

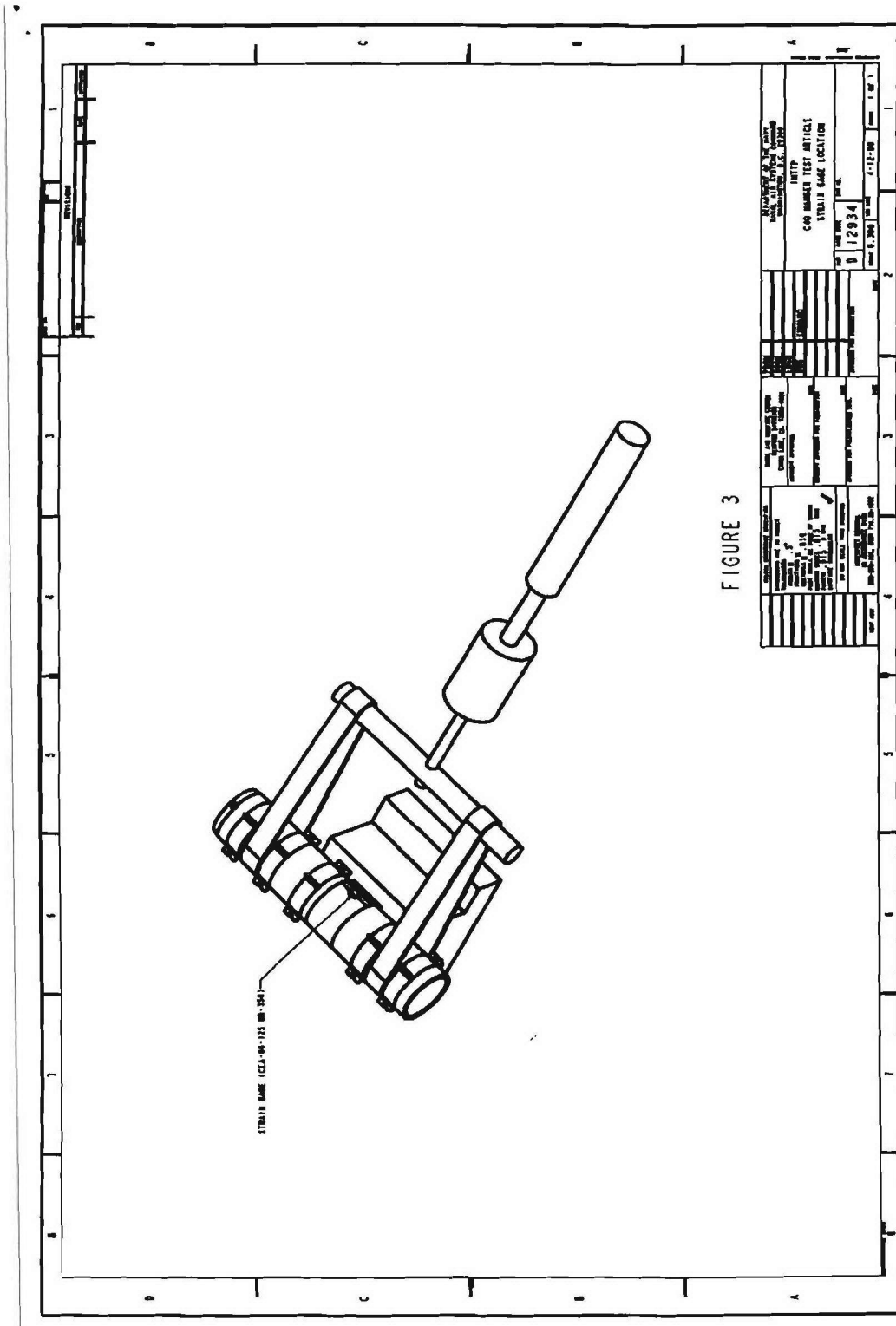

FIGURE K-3. Instrumentation Placement.

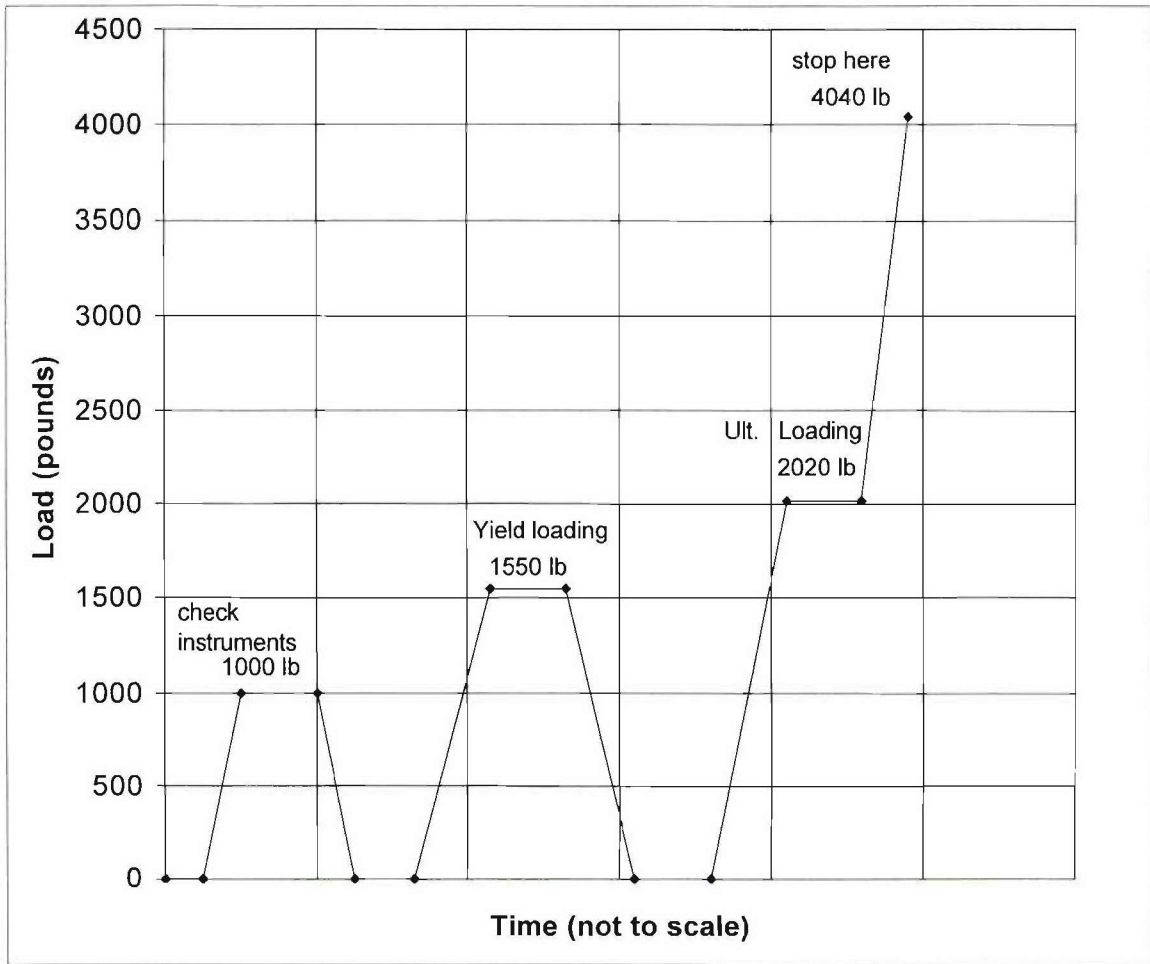

FIGURE K-4. Load Schedule.

Appendix L
COMPOSITE CASE CAPTIVE CARRY QUALIFICATION (C⁴Q)
BLUE TUBE AFT HANGER TEST REPORT

(This page intentionally left blank.)

CONTENTS

Test Description L-5
 Introduction..... L-5
 Test Specimen..... L-5
 Loading Condition..... L-5

Analysis of Loading..... L-6
 Aft Hanger Loading Development..... L-6

Test Results L-7
 Yield Test..... L-7
 Ultimate Test..... L-7

Summary..... L-9

Figures:

L-1. All-up-round (AUR) Structural Layout..... L-5
L-2. Aft Hanger Loading Fixture..... L-6
L-3. Aft Hanger Test Load History L-8
L-4. Yield Test Hoop Strain Data History..... L-8
L-5. Ultimate Test Hoop Strain Data..... L-9

(This page intentionally left blank.)

TEST DESCRIPTION

INTRODUCTION

The Composite Case Captive Carry Qualification (C⁴Q) blue tube aft hanger test is a full-scale structural test of the composite blue tube. The goal was to simulate the worst-case captive carriage load on the aft hanger. This test, in combination with other testing, is intended to demonstrate the structural adequacy of the C⁴Q blue tube design. This test is performed on a full-scale specimen at room temperature. The test yielded a margin of safety (M.S.) of +1.09 for the aft hanger while at station 1 or 9 (wing tip) of the F/A-18C/D. This was with a 1.5 factor of safety for ultimate load.

TEST SPECIMEN

For reference, Figure L-1 shows the basic structural layout of the CATM-9M with the C⁴Q hardware. The test article consists of the aft segment of the composite tube with the aft hanger attached. The segment is 26 inches in length (cut at the forward end of the aft tube fitting). The aft hanger bolts are installed wet with epoxy at a torque of 240 in-lb.

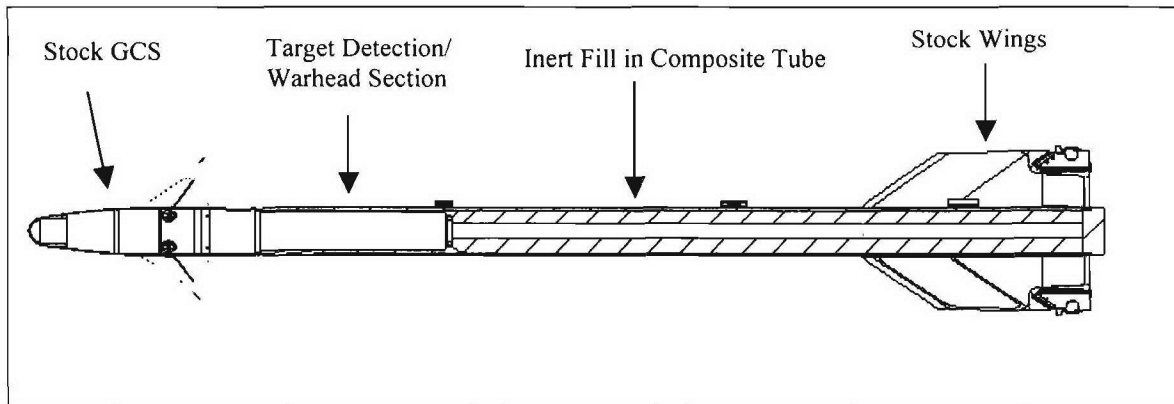

FIGURE L-1. All-up-round (AUR) Structural Layout.

LOADING CONDITION

The specimen was loaded to simulate the load direction and magnitude of the aft hanger on the wing tip stations during the worst-case maneuver (the Mk 84 bomb release). The loading was raised to yield level and returned to zero in order to confirm that no permanent deformation occurred. The loading was then raised until it reached a level approximately three times the limit load. The aft hanger is not critical for captive carriage loads, so failure was not anticipated. Limiting the testing to a large margin, but not to failure, allows the use of the test specimen for the upcoming wing attachment testing. The specimen, fixtures, and loading sequence can be seen in detail in the test plan (Appendix K) and in Figure L-2.

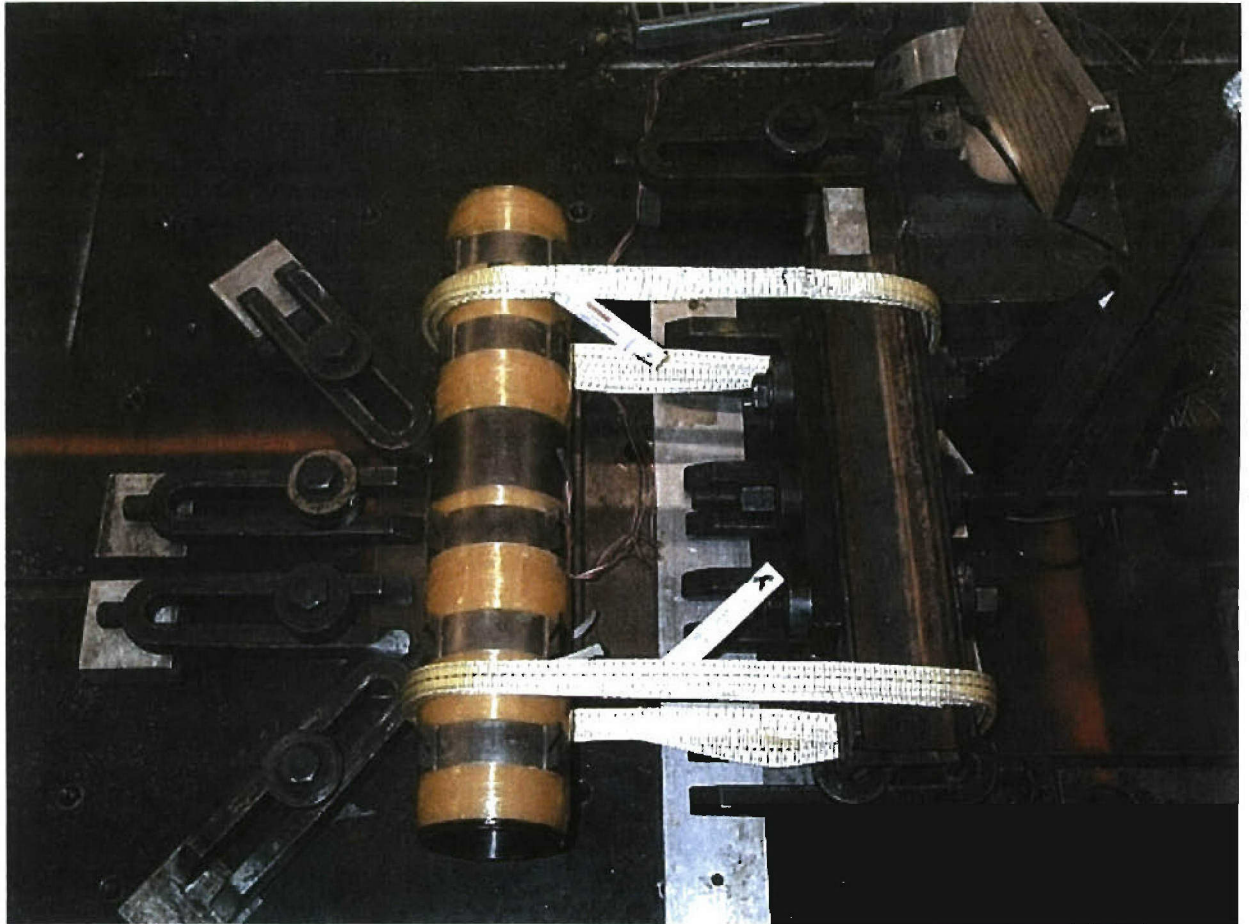

FIGURE L-2. Aft Hanger Loading Fixture.

ANALYSIS OF LOADING

AFT HANGER LOADING DEVELOPMENT

The development of the aft hanger loading value is based on the assumption that the metal hanger or the hanger attachment bolts will fail before the composite tube. Therefore, the load requirement is not exaggerated to cover the reduced composite material properties due to hot/wet conditions and impact damage. The magnitude of the load corresponds to the reactions in the finite element loads model at the aft hanger due to the Mk 84 release condition (worst-case limit load). This is a limit load in the missile Y direction of 1348 pounds.

Equations L-1 through L-3 apply.

$$\text{Yield Load} = 1348 \times 1.15 = 1550 \text{ pounds} \quad (\text{L-1})$$

$$\text{Ultimate Load} = 1348 \times 1.50 = 2020 \text{ pounds} \quad (\text{L-2})$$

$$\text{End of test} = 1348 \times 3.0 = 4040 \text{ pounds} \quad (\text{L-3})$$

TEST RESULTS

The test plan is included as Appendix K. It contains the procedures and figures needed to execute the test. The test was performed on 4 May 2000. All fixtures and instrumentation performed as expected. The test was performed in two stages. The first stage was to increase the load to the yield load and back down to zero. The second stage was to increase the load to ultimate and on up to the end of test limit. Figure L-3 shows the actual applied load history.

YIELD TEST

Figure L-4 shows the hoop strain data for the yield test. This was the dominant strain direction and provides the best indication of the structural response. The hoop strain is quite low. The strain data do return to the original value, meeting the yield test criteria. No deformation or damage was observed.

ULTIMATE TEST

The next stage in the test was to increase the load on the tube until failure. The strain data are presented in Figure L-5.

As the load was increased, there were no signs of damage. The strain data return to the original value and there were no signs of plastic deformation.

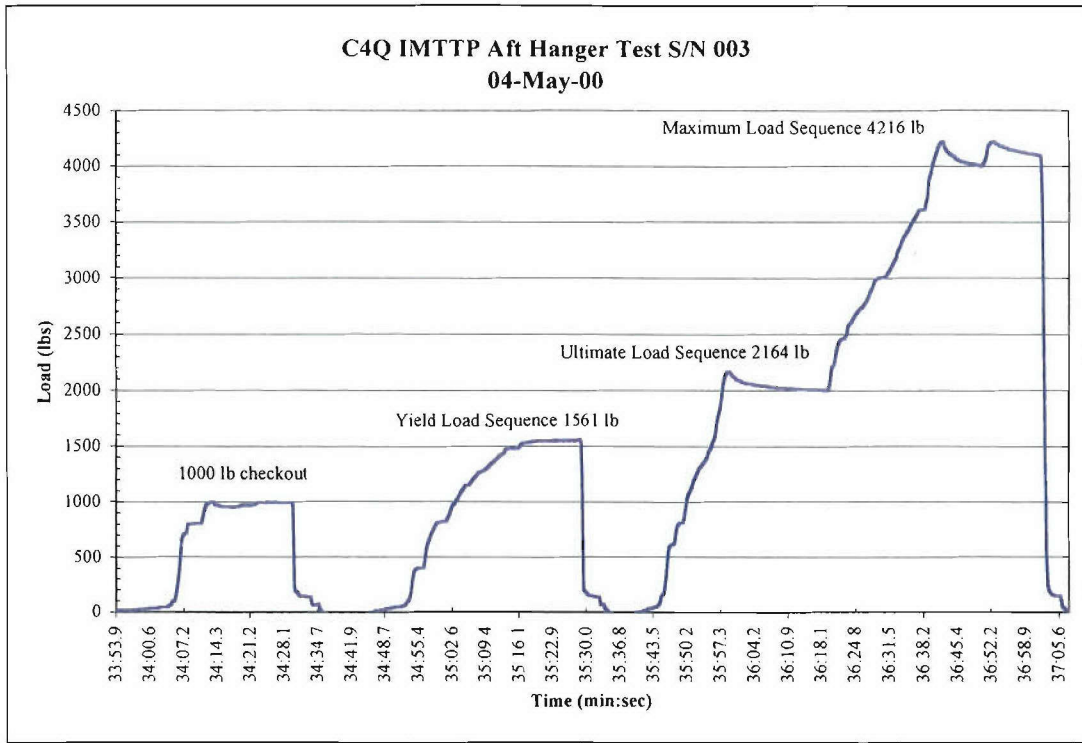

FIGURE L-3. Aft Hanger Test Load History.

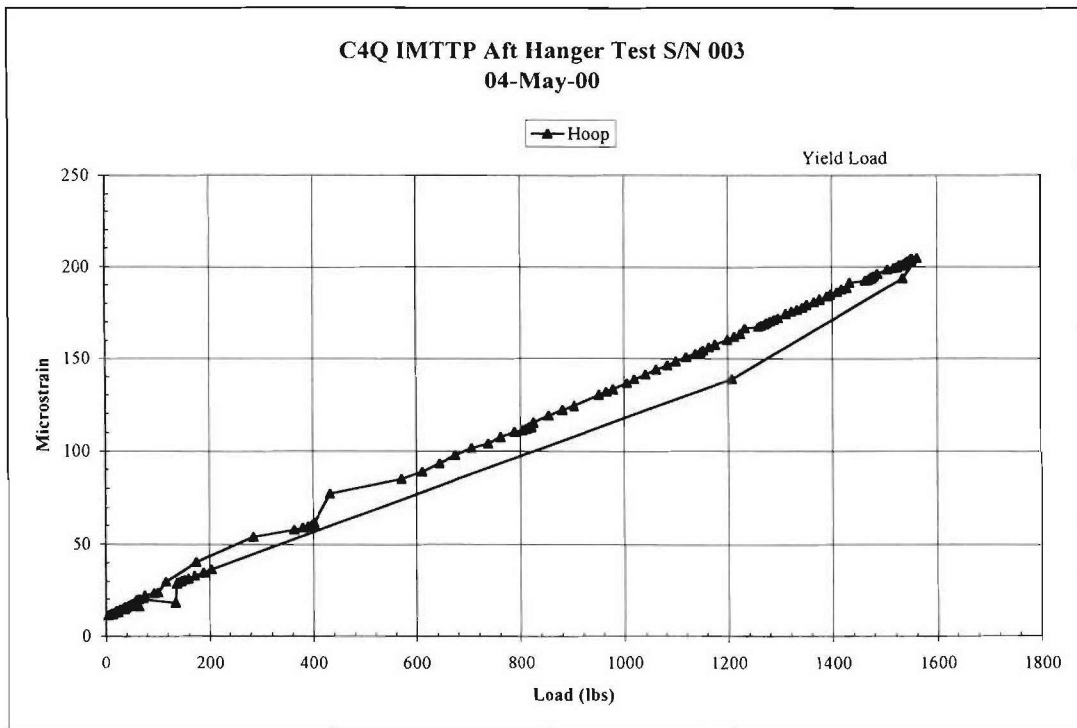

FIGURE L-4. Yield Test Hoop Strain Data History.

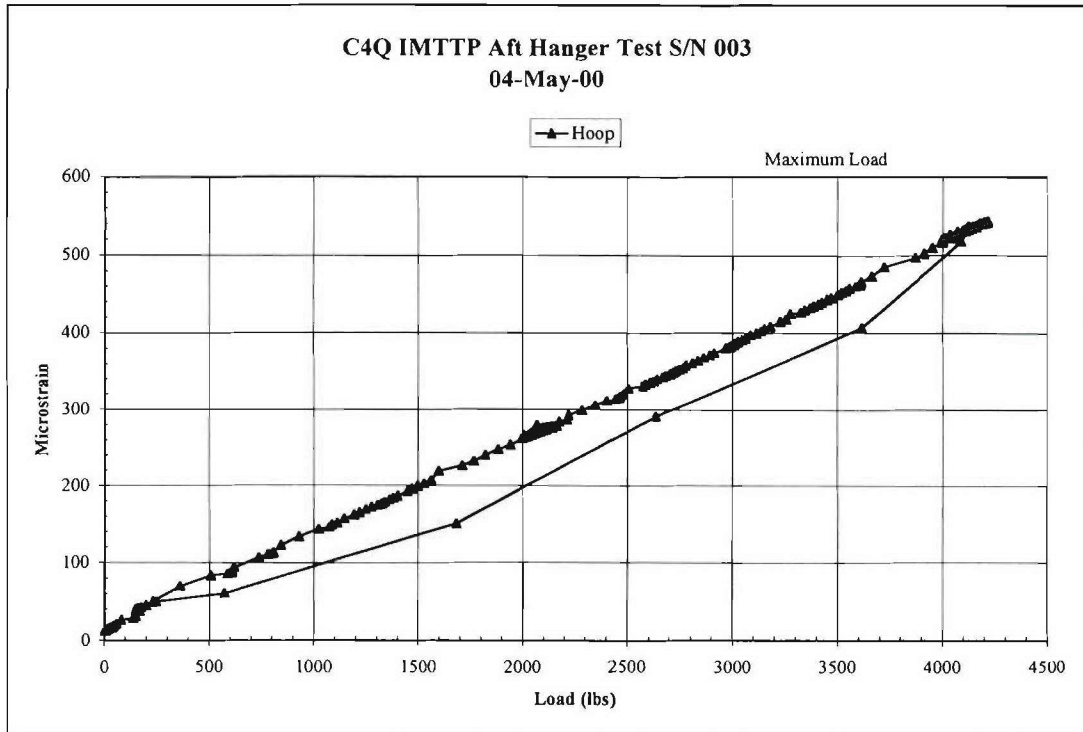

FIGURE L-5. Ultimate Test Hoop Strain Data.

SUMMARY

The C⁴Q composite blue tube passed the ultimate aft hanger load test. Based on the required load of 2020 pounds and the maximum tested load of 4220 pounds, the minimum M.S. for the aft hanger is determined via Equation L-4.

$$M.S. = \frac{4220}{2020} - 1 = +1.09 \tag{L-4}$$

Appendix M
COMPOSITE CASE CAPTIVE CARRY QUALIFICATION (C⁴Q)
BLUE TUBE WING ATTACHMENT TEST PLAN

(This page intentionally left blank.)

1.0 INTRODUCTION

This test plan describes the requirements of the Insensitive Munitions Technology Transition Program (IMTTP) Composite Case Captive Carry Qualification (C⁴Q) composite structural verification tests. The wing attachment test is an ultimate load test of the wing to aft tube fitting joint.

2.0 OBJECTIVE

The primary purpose of this test is to verify that design requirements are met. This test plan provides the overall instructions for performing the test.

3.0 TEST DESCRIPTION

The test requirements, as defined by the loads given in the design criteria, will be demonstrated via yield and ultimate testing.

Yield testing consists of applying limit loading (1352-pound side load applied 7.02 inches from the centerline of the missile) times a 1.15 factor for a total applied load of 1550 pounds.

Ultimate testing consists of applying limit load times a 1.5 factor for ultimate testing, resulting in a total applied load of 2030 pounds.

The success criteria are as follows. Yield testing shall be considered successful if the case and wing withstand yield load without anomalous behavior that would be indicative of their inability to perform their intended use. This shall be determined by inspection (visual and dimensional) and comparison of data (strains and deflections) with predicted values.

Ultimate load testing shall be considered successful if the case and wing fail in the predicted manner at 1.5 or higher load factor.

3.1 TEST ARTICLE DESCRIPTION

The test article consists of the aft part of an IMTTP C⁴Q composite tube (Serial Number 005), shown in Figure M-1. (Note: All of the figures are provided at the end of this document.) The test article consists of a segment of the composite tube including the aft tube fitting. The original segment is 26 inches in length (cut just forward of the aft tube fitting), which is then trimmed to 24 inches as shown to fit into the test fixture.

3.2 TEST FACILITIES

The test facility is located at the Code 476300D environmental laboratory. Wing tests will be done on the static load test equipment.

The test equipment for the wing attachment test consists of a Baldwin 60,000-pound tensile/compression test machine.

The test fixturing to be used for the wing test will include an aft section holding fixture (clamped to the load test frame) and a loading pad attached to the wing. The components of the test fixture are shown in Figures M-2 and M-3; and the assembly is shown in Figure M-4.

4.0 INSTRUMENTATION AND DATA REQUIREMENTS

The instrumentation requirements for these tests will be the same for both proof (yield) and ultimate tests. In this case, a single displacement potentiometer will be used to measure the deflection of the wing during loading. The placement of the instrumentation is also shown in Figure M-4.

The accuracy requirements for the instrumentation through the data recording system shall be as provided in Table M-1.

TABLE M-1. Accuracy Requirements for Instrumentation.

Load Cell	± 10.0 lb
Displacement Potentiometers	± 0.01 inch

The test data shall be reduced and plotted at five samples per second. Two copies of all printouts and plots are required. The digital listings (printouts) will have the strain and displacement as a function of load. Digital plotting will be in the format provided in Table M-2.

TABLE M-2. Digital Plotting Format.

Instrumentation	Abscissa	Ordinate
Load (shear load) cell	Time, seconds	0 to 10,000 lb
Displacement	Load, lb	Displacement, in

5.0 TEST PROCEDURE AND SETUP

5.1 WING ATTACHMENT LOAD TESTS

1. Place aft section test article into the holding fixture.
2. Attach the wing to aft section.
3. Attach the wing loading pad to the wing.
4. Position and attach the holding fixture to the loading frame.
5. Connect all instrumentation.
6. Take pretest photographs of the test setup.
7. Slowly raise the load to 500 pounds and then lower the load back to zero. Observe strain gage and displacement readings. Verify all instrumentation is operating properly.
8. Once correct instrumentation operation has been confirmed, start recording data and begin to raise the load in accordance with Figure M-5.
9. Turn off instrumentation and disconnect all lead wiring and fixtures.
10. Note all anomalies during and after the testing.
11. Take post-test photographs of the test setup.
12. Remove test article (see Sections 5.1.1 and 5.1.2).

5.1.1 Test Precautions

Extreme care should be taken in handling the remains of the case after the test is completed. All the tests must comply with all Code 476300D safety requirements.

5.1.2 Test Article Disposition

The aft tube fitting and wing attachment joint will be post inspected after proof (yield) and ultimate tests by Code 476J00D personnel. The tube will be delivered to Code 476J00D after the ultimate test.

6.0 SUMMARY

Following this wing attachment load test, a summarized report shall be drafted describing the test and the results. Pertinent diagrams and graphs shall be included.

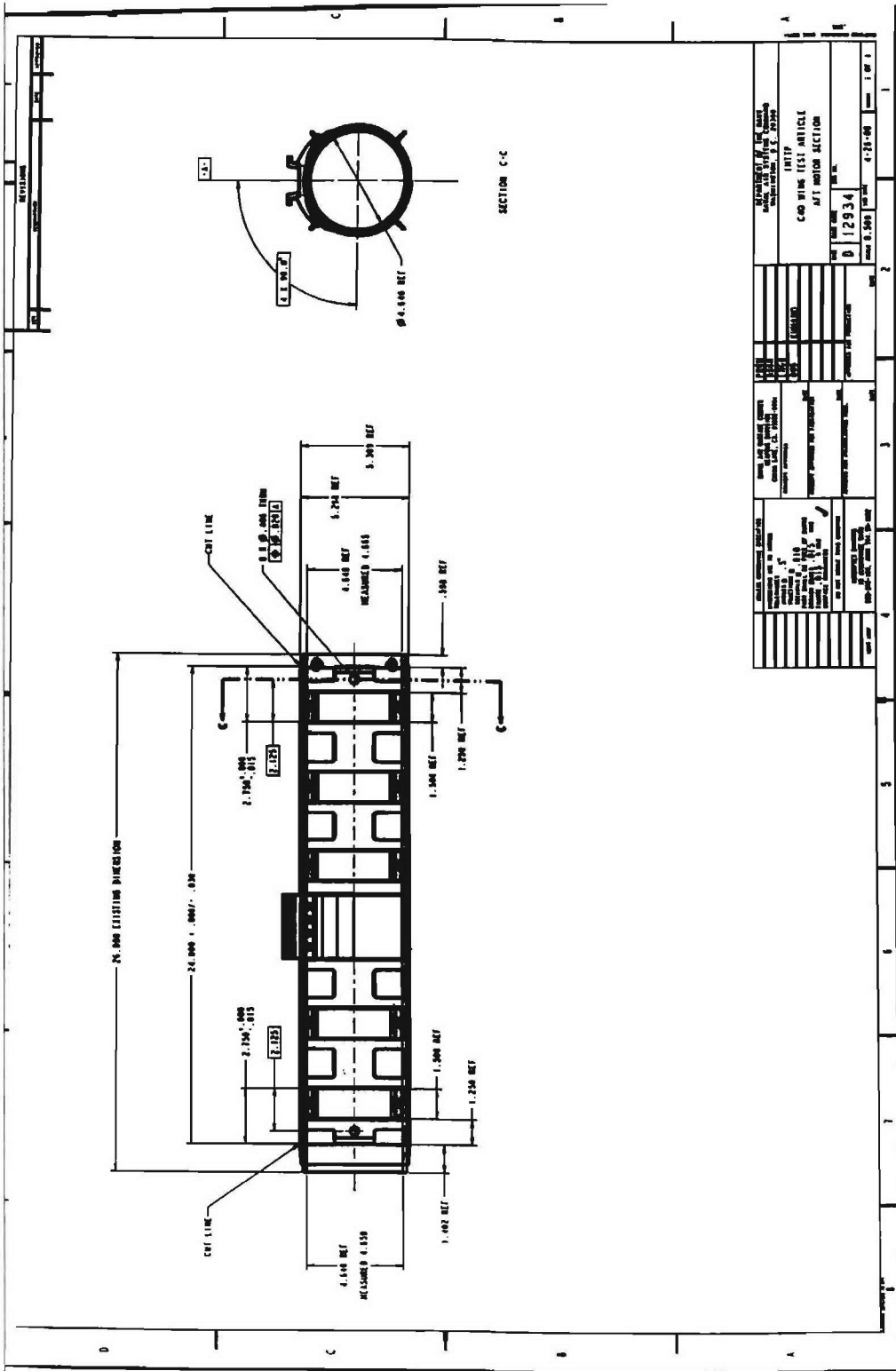

FIGURE M-1. Aft Part of IMTP C⁴Q Composite Tube.

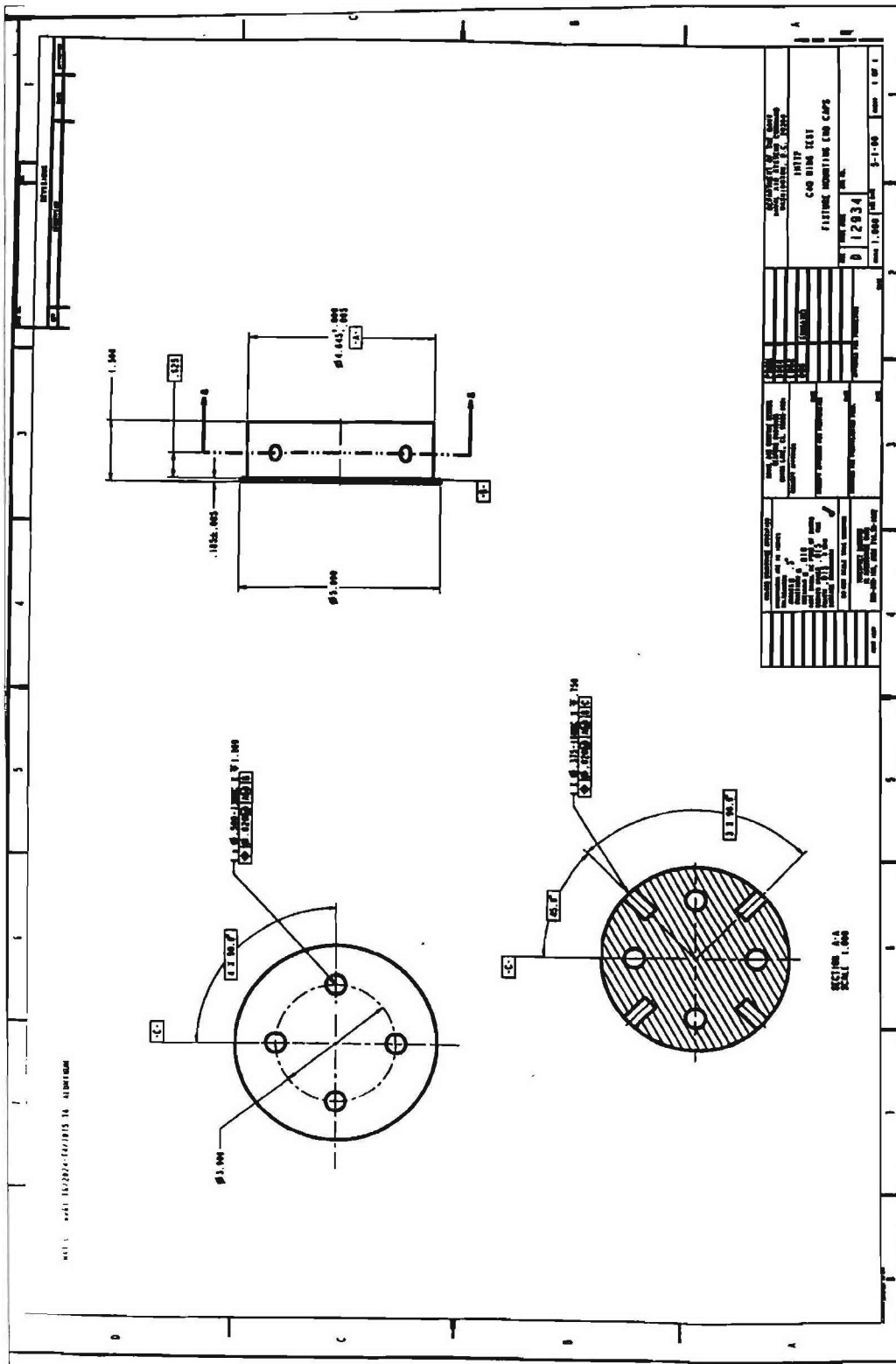

FIGURE M-3. Text Fixture Layout (2 of 2).

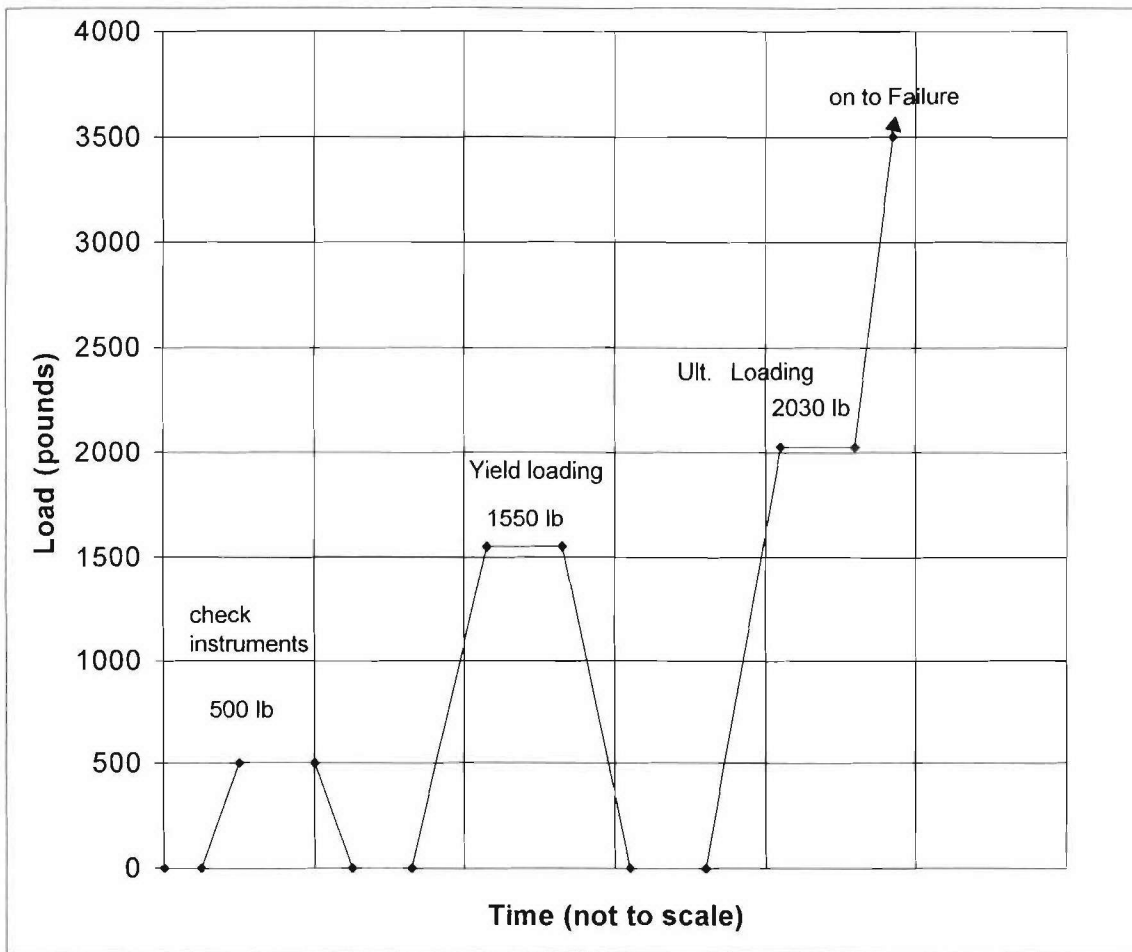

FIGURE M-5. Load Schedule.

Appendix N
COMPOSITE CASE CAPTIVE CARRY QUALIFICATION (C⁴Q)
BLUE TUBE WING ATTACHMENT TEST REPORT

(This page intentionally left blank.)

CONTENTS

Test Description	N-5
Introduction.....	N-5
Test Specimen.....	N-5
Loading Condition.....	N-5
Analysis of Loading.....	N-7
Wing Loading Development.....	N-7
Test Results	N-7
Yield Test.....	N-7
Ultimate Test.....	N-7
Summary.....	N-9

Figures:

N-1. All-up-round (AUR) Structural Layout.....	N-5
N-2. Wing Test Loading Fixture (Front Side).....	N-6
N-3. Wing Test Loading Fixture (Back Side).....	N-6
N-4. Wing Attachment Test Load History.....	N-8
N-4. Yield Test Wing Load Displacement Data.....	N-8
N-4. Ultimate Test Wing Load Displacement Data	N-9

(This page intentionally left blank.)

TEST DESCRIPTION

INTRODUCTION

The Composite Case Captive Carry Qualification (C⁴Q) blue tube wing attachment test is a full-scale structural test of the composite blue tube. The goal was to simulate the worst-case captive carriage air loads on the wing. This test, in combination with other testing, is intended to demonstrate the structural adequacy of the C⁴Q blue tube design. This test is performed on a full-scale specimen at room temperature. The test showed an ultimate margin of safety (M.S.) of +0.55 for the wing attachment with the failure of the wing as the mode. This was with a 1.5 factor of safety for ultimate load.

TEST SPECIMEN

For reference, Figure N-1 shows the basic structural layout of the CATM-9M with the C⁴Q hardware. The test article consists of the aft segment of the composite tube with one wing attached. The segment is 24 inches in length (cut at the forward end of the aft tube fitting). Radial fasteners were added at the ends of the specimen to hold it in the test fixture

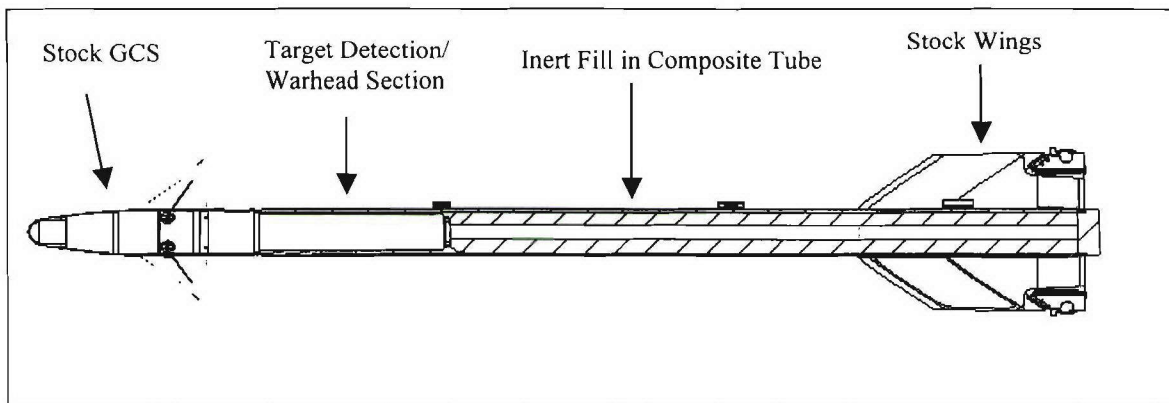

FIGURE N-1. All-up-round (AUR) Structural Layout.

LOADING CONDITION

The specimen was loaded to simulate worst lateral air load on the wing. This was applied at the center of pressure. The loading was raised to yield level and returned to zero in order to confirm that no permanent deformation occurred. The loading was then raised to ultimate and held long enough to confirm its performance. The load was then raised until failure occurred. The specimen, fixtures, and loading sequence can be seen in detail in the test plan (Appendix M) and in Figures N-2 and N-3.

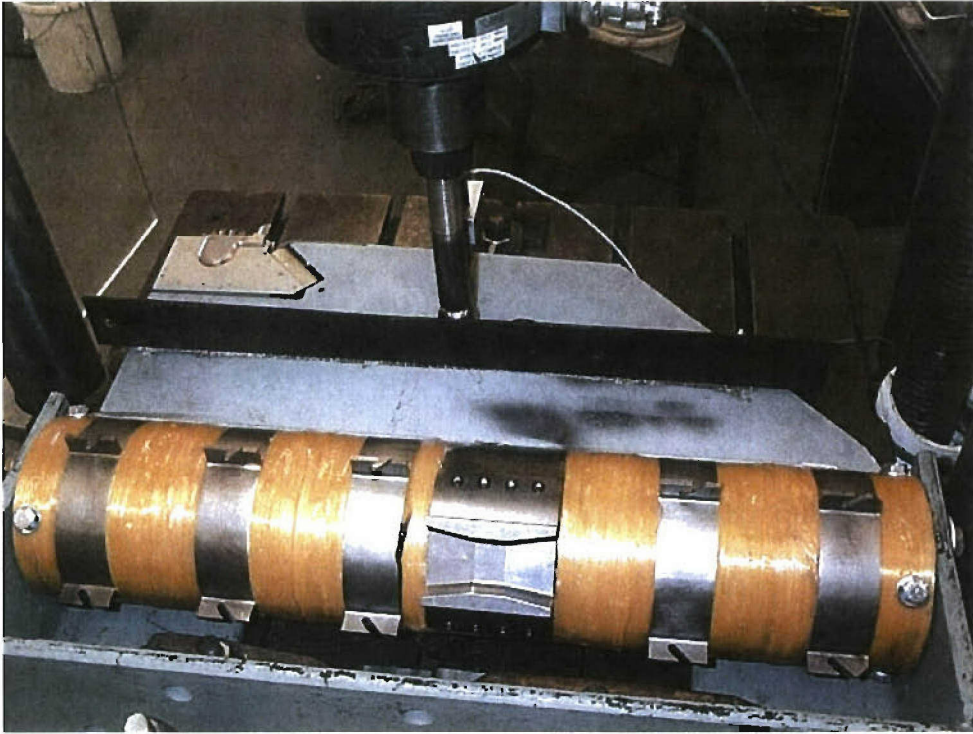

FIGURE N-2. Wing Test Loading Fixture (Front Side).

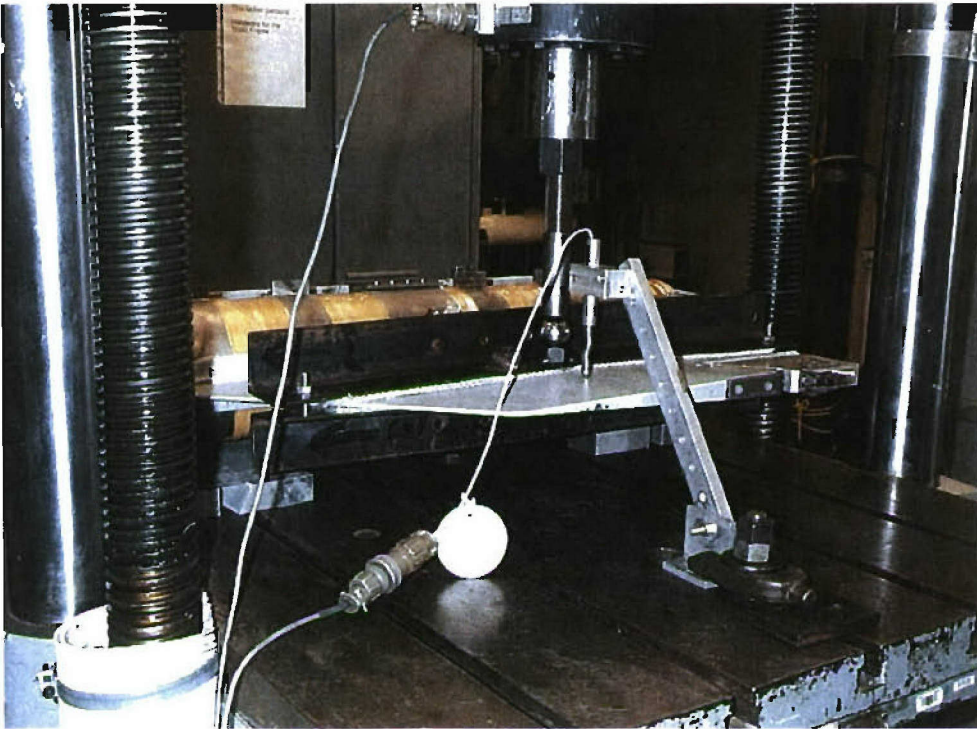

FIGURE N-3. Wing Test Loading Fixture (Back Side).

ANALYSIS OF LOADING

WING LOADING DEVELOPMENT

The development of the wing loading is based on the design criteria, which is in turn based on the values in NAWCWPNS TM 6344, Rev. 1, fin and wing loads.

The magnitude of the load corresponds to flow condition 4B on wing 2. This is a limit load perpendicular to the wing surface of 1350 pounds acting 7.02 inches out from the center of the missile.

Equations N-1 and N-2 apply.

$$\text{Yield Load} = 1352 \times 1.15 = 1550 \text{ pounds} \quad (\text{N-1})$$

$$\text{Ultimate Load} = 1352 \times 1.50 = 2030 \text{ pounds} \quad (\text{N-2})$$

TEST RESULTS

The test plan is included in Appendix M. It contains the procedures and figures needed to execute the test. The test was performed on 7 June 2000. All fixtures and instrumentation performed as expected. The test was performed in two stages. The first stage was to increase the load to the yield load and back down to zero. The second stage was to increase the load to ultimate and on up failure. Figure N-4 shows the actual applied load history.

YIELD TEST

Figure N-5 shows displacement data for the yield test. This was from the displacement transducer as seen in the setup (Figure N-3). The displacement data return almost to the original value, meeting the yield test criteria. No deformation or damage was observed. The small amount of residual deflection after unloading is due to settling of the test fixture and instrumentation rather than plastic deformation in the parts.

ULTIMATE TEST

The next stage in the test was to increase the load on the tube until failure. The strain data are presented in Figure N-6. As the load was increased, there were no signs of damage until failure at 3143 pounds. There were obvious signs of wing failure. There was no damage to the wing attachment tabs or aft tube fitting. The load was continued a little further, just to see if the damaged wing could sustain ultimate loads for a while. The wing attachment and aft tube fitting of the C⁴Q blue tube passed the ultimate test, with no signs of damage or plastic deformation.

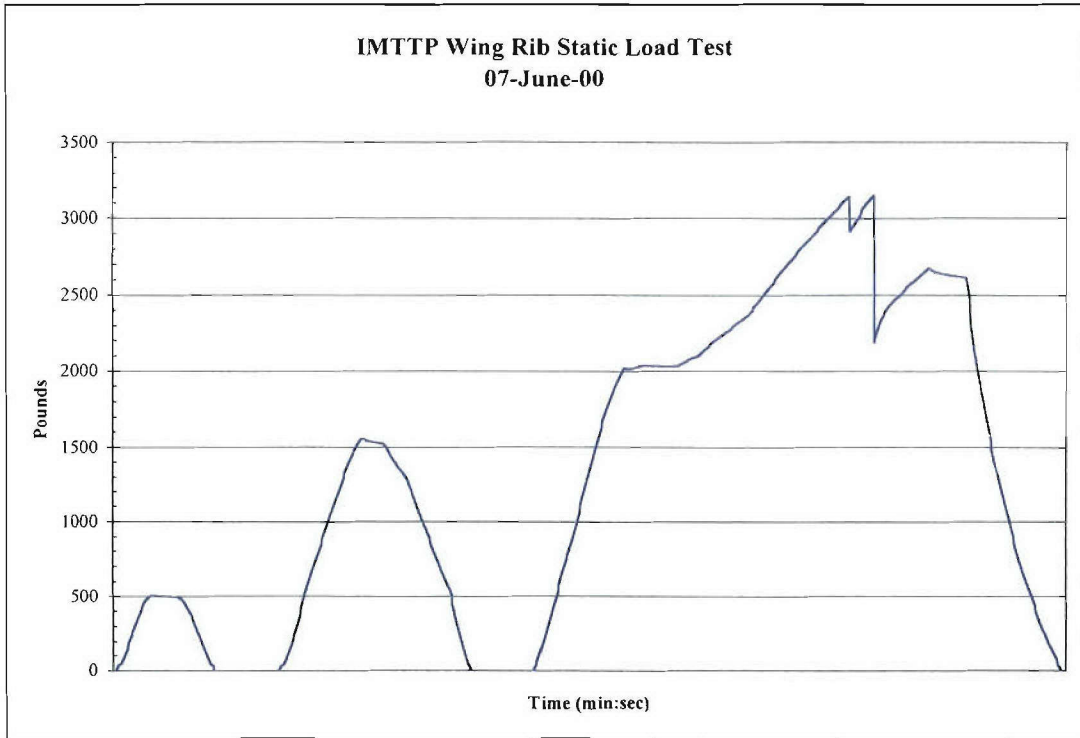

FIGURE N-4. Wing Attachment Test Load History.

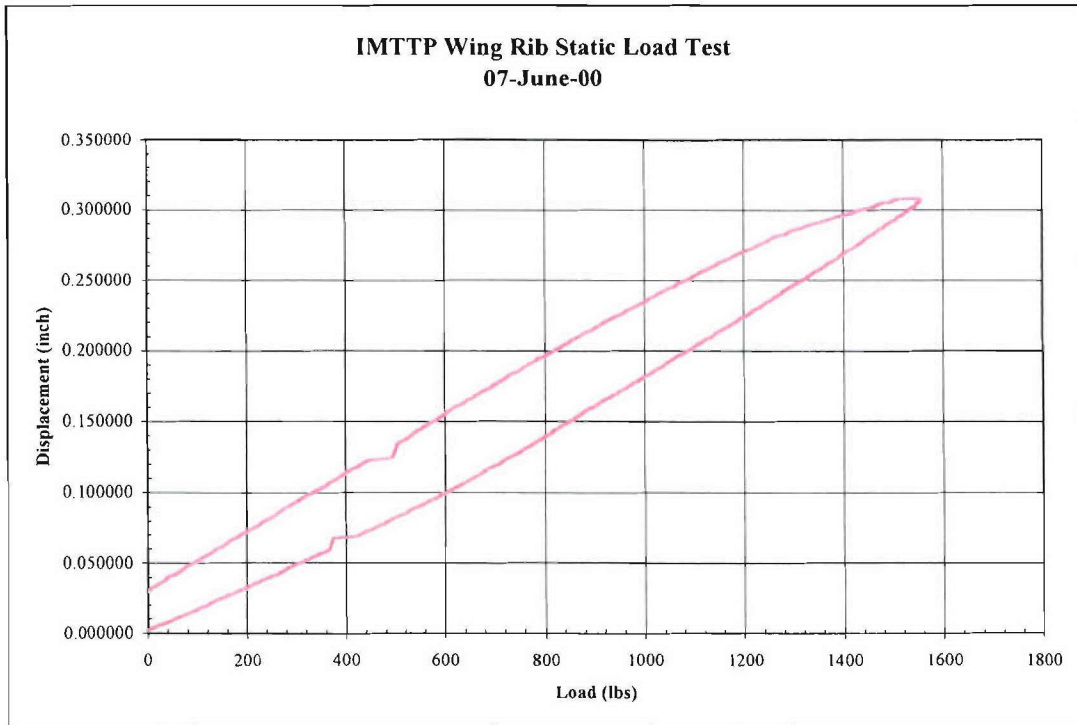

FIGURE N-5. Yield Test Wing Load Displacement Data.

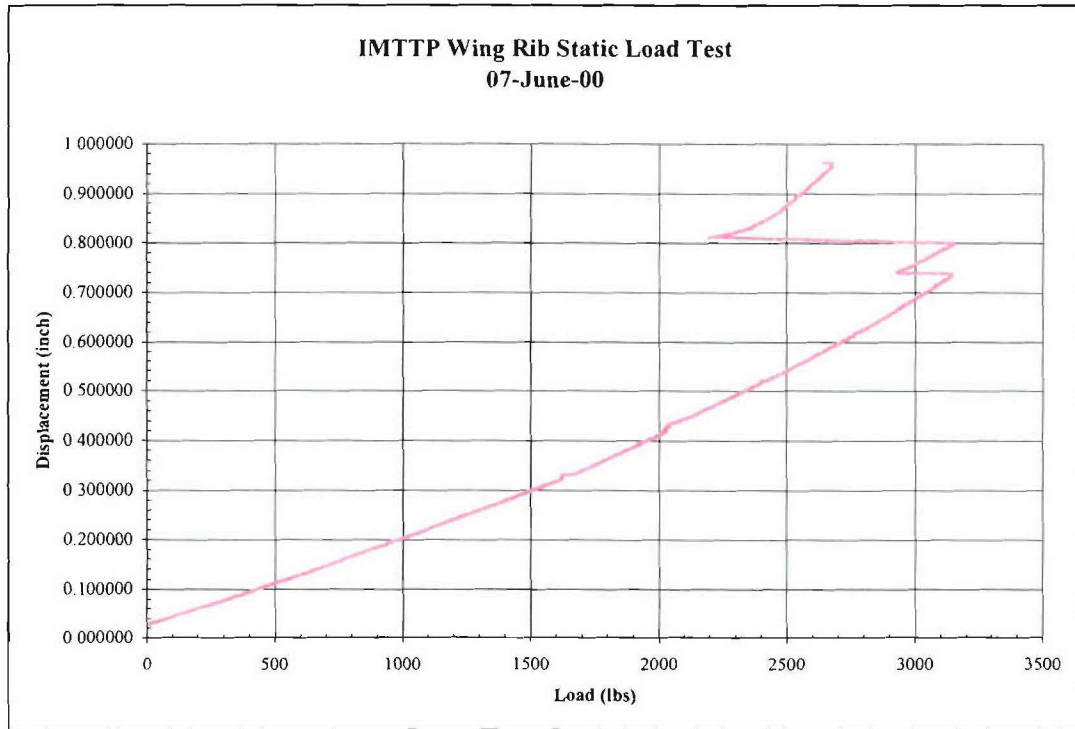

FIGURE N-6. Ultimate Test Wing Load Displacement Data.

SUMMARY

The C⁴Q composite blue tube passed the ultimate wing attachment load test. Based on the required load of 2030 (limit × 1.5) pounds and the maximum tested load of 3140 pounds, the minimum M.S. for the aft hanger is determined via Equation N-3.

$$M.S. = \frac{3140}{2030} - 1 = +0.55 \quad (N-3)$$

Appendix O
COMPOSITE CASE CAPTIVE CARRY QUALIFICATION (C⁴Q)
BLUE TUBE FATIGUE TEST PLAN

(This page intentionally left blank.)

1.0 INTRODUCTION

This test plan describes the full-scale fatigue test that will demonstrate that the Composite Case Captive Carry Qualification (C⁴Q) hardware meets the fatigue requirements of the Insensitive Munitions Technology Transition Program (IMTTP) C⁴Q composite blue tube.

2.0 OBJECTIVE

The primary purpose of this test is to verify that design requirements are met. This test plan provides the overall instructions for conducting fatigue testing of the IMTTP 5.0-inch composite tube.

3.0 TEST DESCRIPTION

Additional information on the fatigue loading spectrum has been obtained since the time of the Structural Design Criteria for the C⁴Q Hardware for the CATM-9M Report. The spectrum is a g exceedance spectrum for the AIM-9M on the wing tip station of the F/A-18C/D in the aircraft Z direction. It is described as the "Complete Appended and Racetracked End-Level Sequence for Four Flight Scenarios" in NWC TM 6526, Revision 1 (May 1991); and the data are on file in the Life-cycle Environmental Engineering Branch (Code 476300D/E). The spectrum consists of 3565 cycles, representing 22.1 hours of life. With the use of this spectrum, it is possible (and desirable) to perform a full-scale fatigue test for the C⁴Q hardware.

The fatigue life requirement is still as defined in the design criteria, where a single lifetime is defined as 300 hours, 100 cats and traps, and 100 conventional take-offs and landings. The magnitude of the spectrum is increased by 13% to cover the additional scatter of the composite materials' fatigue response. As an alternative, we can test to two lifetimes at nominal loads to proof all the metal bits, then continue the loads for two more lifetimes, and only require the composite to succeed for a good test. The second approach is selected for this test due to the test times being reasonably short. It also allows the test to prove the life of the metallic components.

The success criteria are as follows. Fatigue testing shall be considered successful if the case withstands two lifetimes without anomalous behavior in the metallic components that would be indicative of its inability to perform its intended use. Additionally, the composite portion of the structure must withstand two more lifetimes to cover the extra material scatter for composites. This shall be determined by inspection (visual and dimensional) and by any large redistribution of strains as indicated by the instrumentation.

3.1 TEST ARTICLE DESCRIPTION

The test article consists of an IMTTP C⁴Q body assembly (Serial Number 008), as described in Drawing Number A476200D-132 (however, the inert fill and aft end cap are not required). The cases are wound by using IM-7 graphite fiber embedded in an epoxy resin. The graphite/epoxy winding lay-up consists of helical (14-degree), axial (0-degree), and hoop (90-degree) layers. A Kevlar overwrap hoop layer is used for protection. The test article is shown in Figure O-1. (Note: All of the figures are provided at the end of this document.)

3.2 TEST FACILITIES

The test facility is located at the Code 476300D static frame test facility.

The test equipment for this fatigue test consists of two hydraulic load jacks, load cells, strain gages, a displacement transducer, and signal conditioning and recording equipment.

The test article is mounted to a launcher simulator designed to match the stiffness of a LAU-7 launcher. The acceleration loads are applied by the hydraulic load jacks through a wiffle tree arrangement. The wiffle trees and load jacks are placed on both sides of the test article to permit the load reversals in the spectrum. The fixture layout is shown in Figure O-2.

4.0 INSTRUMENTATION AND DATA REQUIREMENTS

All strain gages are 45-degree rectangular rosette (MM CEA-06-125 UR-350) gages. The placement of the instrumentation is shown in Figure O-3.

The accuracy requirements for the instrumentation through the data recording system shall be as provided in Table O-1.

TABLE O-1. Accuracy Requirements for Instrumentation.

Strain Gages	±0.08% strain
Load Cell	±10.0 lb

The test data shall be reduced and plotted. Two copies of all printouts and plots are required, as well as the bulk data. The digital listings (printouts) will have the strain and displacement as a function of load. Digital plotting will be in the format provided in Table O-2

TABLE O-2. Digital Plotting Format.

Instrumentation	Abscissa	Ordinate
Load (shear load) cell	Time, seconds	0 to 5000 lb
Strain gages (SG1-SG12)	Time	-1.0 to 1.0 %

5.0 TEST PROCEDURE AND SETUP

The types of gages are noted in Figure O-3. These gages must be protected and thermal compensation is not required. Prior to the tests, the test director will define selected priority data, which will be immediately processed and reviewed prior to proceeding with the testing.

The general test procedures are as follows.

1. Attach the launch rail simulator to the static test frame.
2. Attach the test article to the launch rail.
3. Attach the wiffle tree clamps to the test article in the locations shown.
4. Assemble the wiffle trees.
5. Attach the wiffle trees to the load jacks.
6. Connect all instrumentation.
7. Take pretest photographs of the test setup.
8. Slowly raise the load to 1900 pounds (10 g) and then lower the load back to zero. Observe strain gage and displacement readings. Verify all instrumentation is operating properly.
9. Slowly raise the load to -1900 pounds (-10 g) and then lower the load back to zero. Observe strain gage and displacement readings. Verify all instrumentation is operating properly.
10. Begin applying the load spectrum continue until two lifetimes (600 equivalent flight hours) are reached.
11. Inspect metal parts for signs of fatigue damage (dye-penetrant).
12. Continue the testing for two more lifetimes.
13. Inspect the composite structure for signs of fatigue damage.
14. Note all anomalies during and after the testing.
15. Take post-test photographs of the test setup.
16. Remove test article (see Sections 5.1 and 5.2).

5.1 TEST PRECAUTIONS

The composite tube will be placed in an isolated area during the test. Hazardous flying debris is possible and all precautions shall be taken to avoid exposure to the debris. Extreme care should be taken in handling the remains of the case after the test is completed. All tests must comply with all Code 476300D safety requirements.

5.2 TEST ARTICLE DISPOSITION

The composite tube will be post inspected after the fatigue test by Code 476J00D personnel. The tube will be delivered to Code 476J00D for sectioning into coupons and cylindrical test articles after the fatigue test.

6.0 SUMMARY

Following each test, a summarized report shall be drafted describing the test and the results. Pertinent diagrams and graphs shall be included.

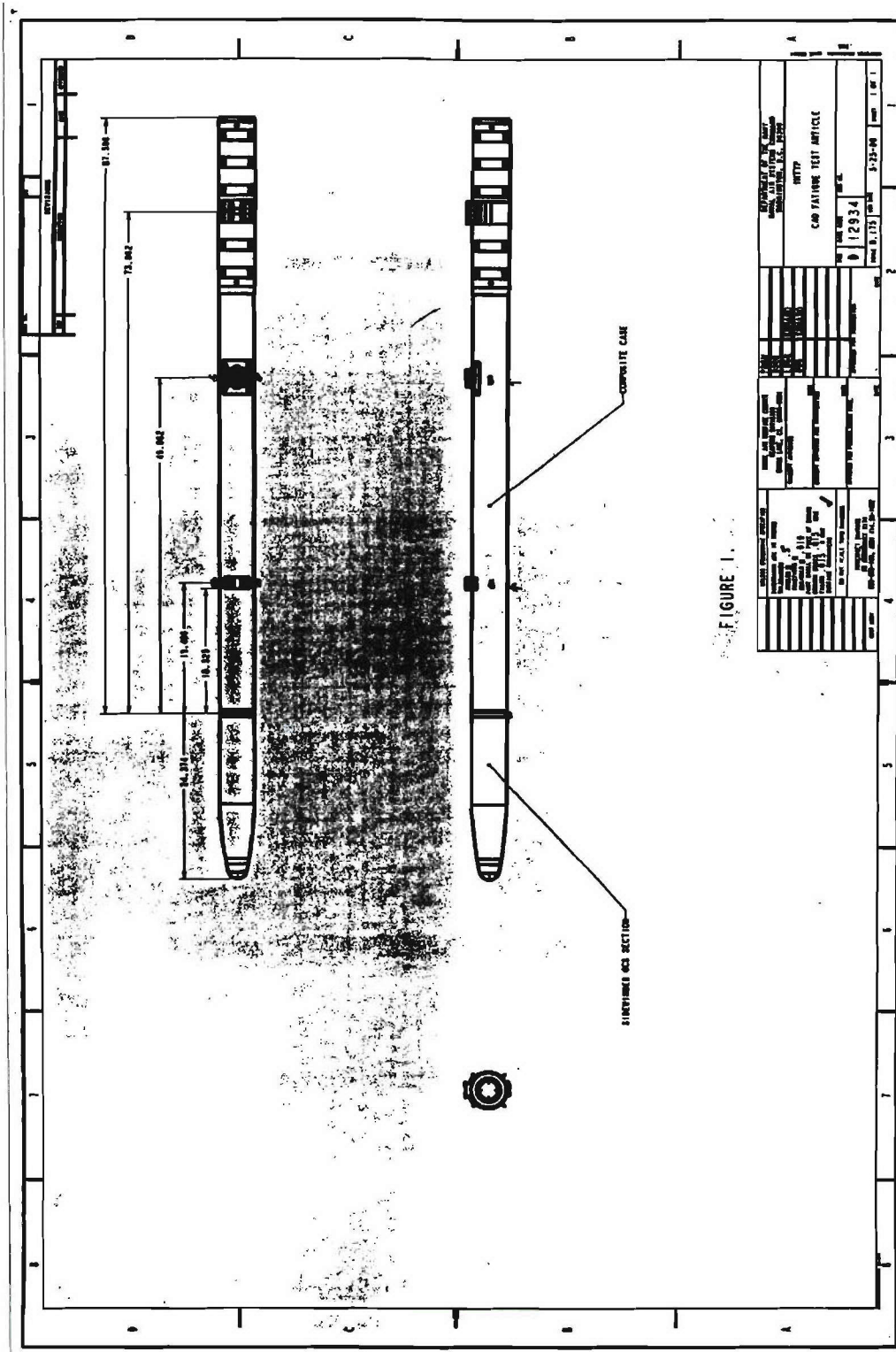

FIGURE O-1. Test Article.

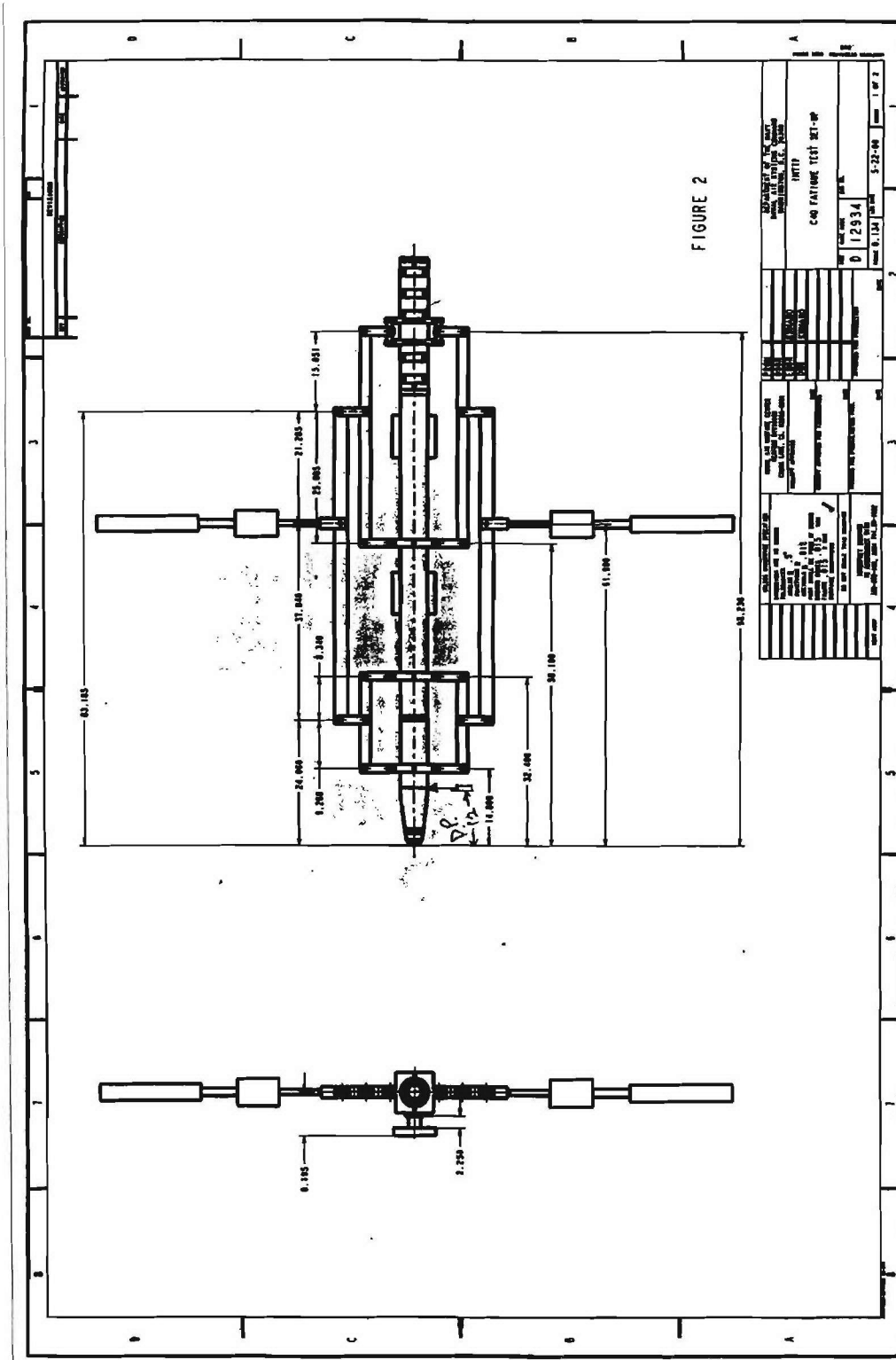

FIGURE O-2. Text Fixture Layout.

Appendix P
COMPOSITE CASE CAPTIVE CARRY QUALIFICATION (C⁴Q)
BLUE TUBE FATIGUE TEST REPORT

(This page intentionally left blank.)

CONTENTS

Test Description	P-5
Introduction.....	P-5
Test Specimen.....	P-5
Loading Condition.....	P-5
Analysis of Loading	P-7
Wiffle Tree and Launcher Development	P-7
Loading Sequence.....	P-8
Test Results	P-9
Inspection Methods.....	P-9
Inspection Results at Beginning of Test.....	P-10
Inspection Results at 600 EFH.....	P-11
Inspection Results at 1200 EFH.....	P-11
Inspection Results After Impact.....	P-12
Inspection Results at 1500 EFH.....	P-12
Strain Results Comparison.....	P-13
Residual Strength.....	P-13
Summary.....	P-14

Figures:

P-1. All-up-round (AUR) Structural Layout.....	P-5
P-2. Test Setup (View 1).....	P-6
P-3. Test Setup (View 2).....	P-6
P-4. Test and Actual Moment Diagram (1 g).....	P-7
P-5. Curve for g Exceedance	P-8
P-6. F/A-18C/D Fatigue Sequence.....	P-9
P-7. Strain Gage Locations	P-10
P-8. Strain History at Maximum Peak Load.....	P-14

Tables:

P-1. Hanger Reactions (by Analysis)	P-7
P-2. Strain Snapshot Just After 0 EFH (Microstrain)	P-11
P-3. Strain Snapshot Just Before 600 EFH (Microstrain)	P-11
P-4. Strain Snapshot Just After 600 EFH (Microstrain).....	P-12
P-5. Strain Snapshot Just Before 1200 EFH (Microstrain)	P-12
P-6. Strain Snapshot Just Before 1500 EFH (Microstrain)	P-13

(This page intentionally left blank.)

TEST DESCRIPTION

INTRODUCTION

The Composite Case Captive Carry Qualification (C⁴Q) blue tube fatigue test is a full-scale structural test of the composite blue tube under a fatigue spectrum loading history. This test, in combination with other testing, is intended to demonstrate the structural adequacy of the C⁴Q blue tube design. The fatigue test article is a full-scale specimen at room temperature and without heat, moisture, or impact damage. The test yielded a conservative fatigue life of 150 hours. Impact damage was introduced at missile stations 47 and 71. One additional lifetime was run and showed a stable increase in the size of the damaged area of the forward location.

TEST SPECIMEN

For reference, Figure P-1 shows the basic structural layout of the CATM-9M with the C⁴Q hardware. The test article omits the wings, fins, and aft plug. The inert fill was omitted as well. None of these items were considered necessary for this test.

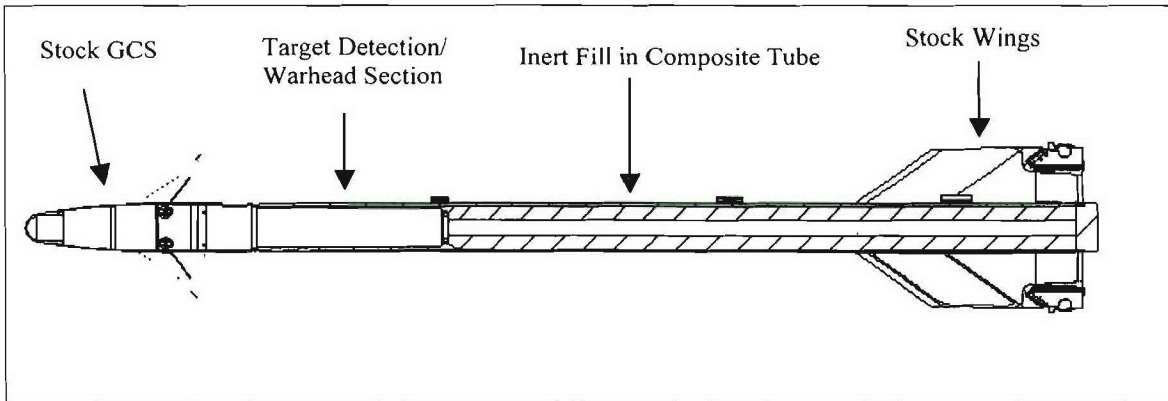

FIGURE P-1. All-up-round (AUR) Structural Layout.

LOADING CONDITION

The specimen was loaded in a wiffle tree fixture. The locations of the load application points were designed to approximate the moment diagram during a 1-g acceleration (gravity). A rectangular section of aluminum bar stock was used to simulate LAU-7 launcher stiffness. The spectrum is a g exceedance spectrum for the AIM-9M on the wing tip station of the F/A-18C/D in the aircraft Z direction. It is described as the "Complete Appended and Racetracked End-Level Sequence for Four Flight Scenarios" in NWC TM 6526, Revision 1 (May 1991); and the data are on file in the Life-cycle Environmental Engineering Branch (Code 476300D/E). The spectrum consists of 3565 cycles, representing 22.1 flight hours of life. The wiffle tree is on both sides of the missile to allow positive and negative loads to be applied (by two actuators). The setup can be seen in Figures P-2 and P-3.

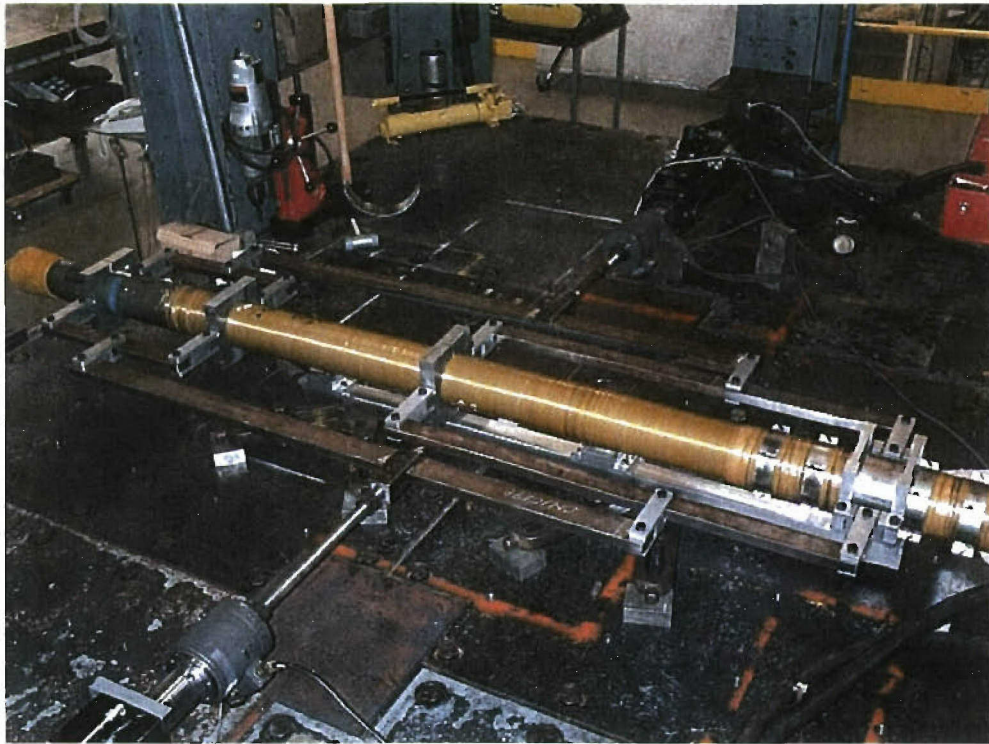

FIGURE P-2. Test Setup (View 1).

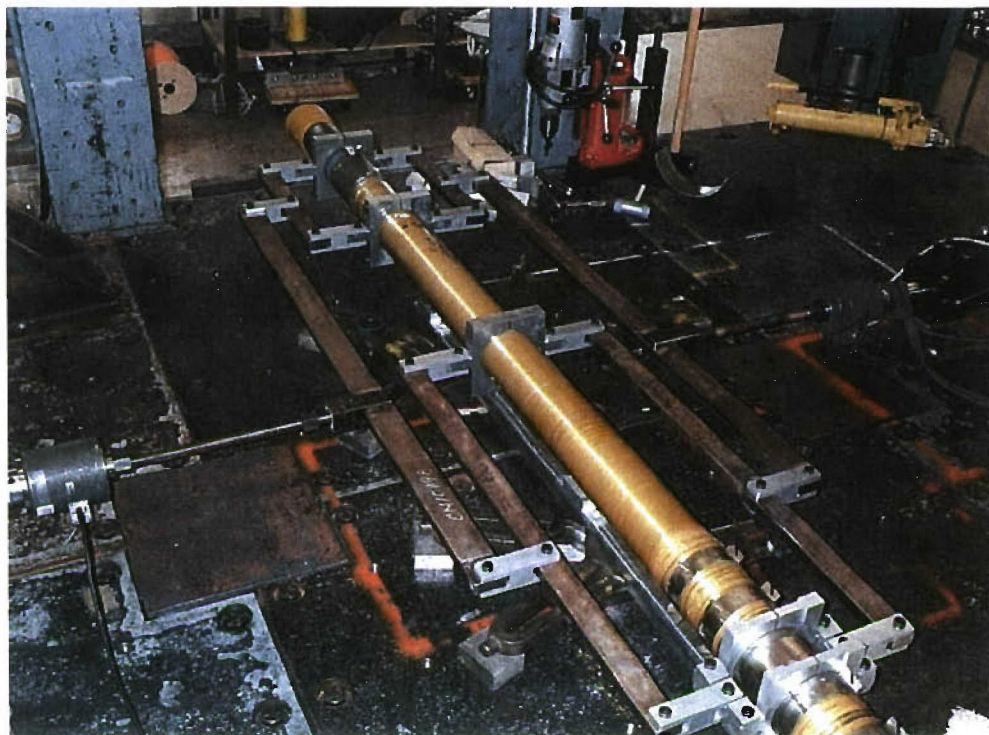

FIGURE P-3. Test Setup (View 2).

ANALYSIS OF LOADING

WIFFLE TREE AND LAUNCHER DEVELOPMENT

The wiffle tree and launcher fixture were designed to produce a representative moment diagram on the missile and to produce appropriate loads on the three hangers for a given *g* level. With a few iterations, it was found that four loading points would sufficiently simulate response to the flight inertial loading. Comparisons of structural response were made using the C⁴Q finite element model (see the C⁴Q design criteria report). Figure P-4 shows the results of the moment diagram comparison, and Table P-1 shows the comparison of the hanger reaction loads.

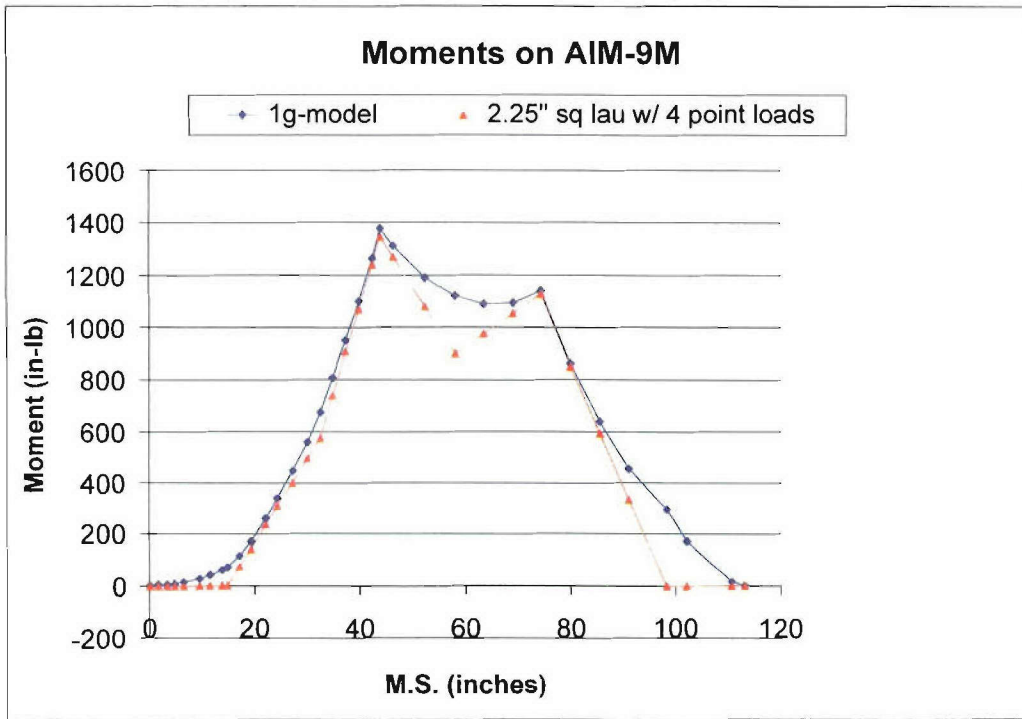

FIGURE P-4. Test and Actual Moment Diagram (1 g).

TABLE P-1. Hanger Reactions (by Analysis).

	1 g (C ⁴ Q Finite Element Model)	190 Pounds Through Wiffle Tree
Forward hanger load, pounds	99.5	99.8
Middle hanger load, pounds	61.3	57.2
Aft hanger load, pounds	25.9	29.0

LOADING SEQUENCE

The fatigue sequence was based upon the missions flown during the tactical operation of the F/A-18. The four mission types are (1) combat air patrol (CAP), (2) Mig sweep, (3) yo-yo, and (4) strike. The missions are estimated to occur 25%, 20%, 5%, and 50%, respectively, of the total mission time flown. Measured AIM-9M captive carry data were used to generate the sequence. The load exceedance curve for 1000 hours of captive carriage is shown in Figure P-5. The sequence used for the test is shown in Figure P-6. The sequence is equivalent to 22 .1 hours of captive carriage, which are comprised of five CAP, four Mig seeps, one yo-yo, and ten strike missions. The sequence has been racetracked at 6 g to remove low-level cycles, which do not significantly contribute to fatigue damage but would increase the required test time (reference: "Development of Load Exceedance Curve for Sidewinder AIM-9M Wing Tip Station of F/A-18 Aircraft," Reg. Memo 3915/028, 1 March 1987).

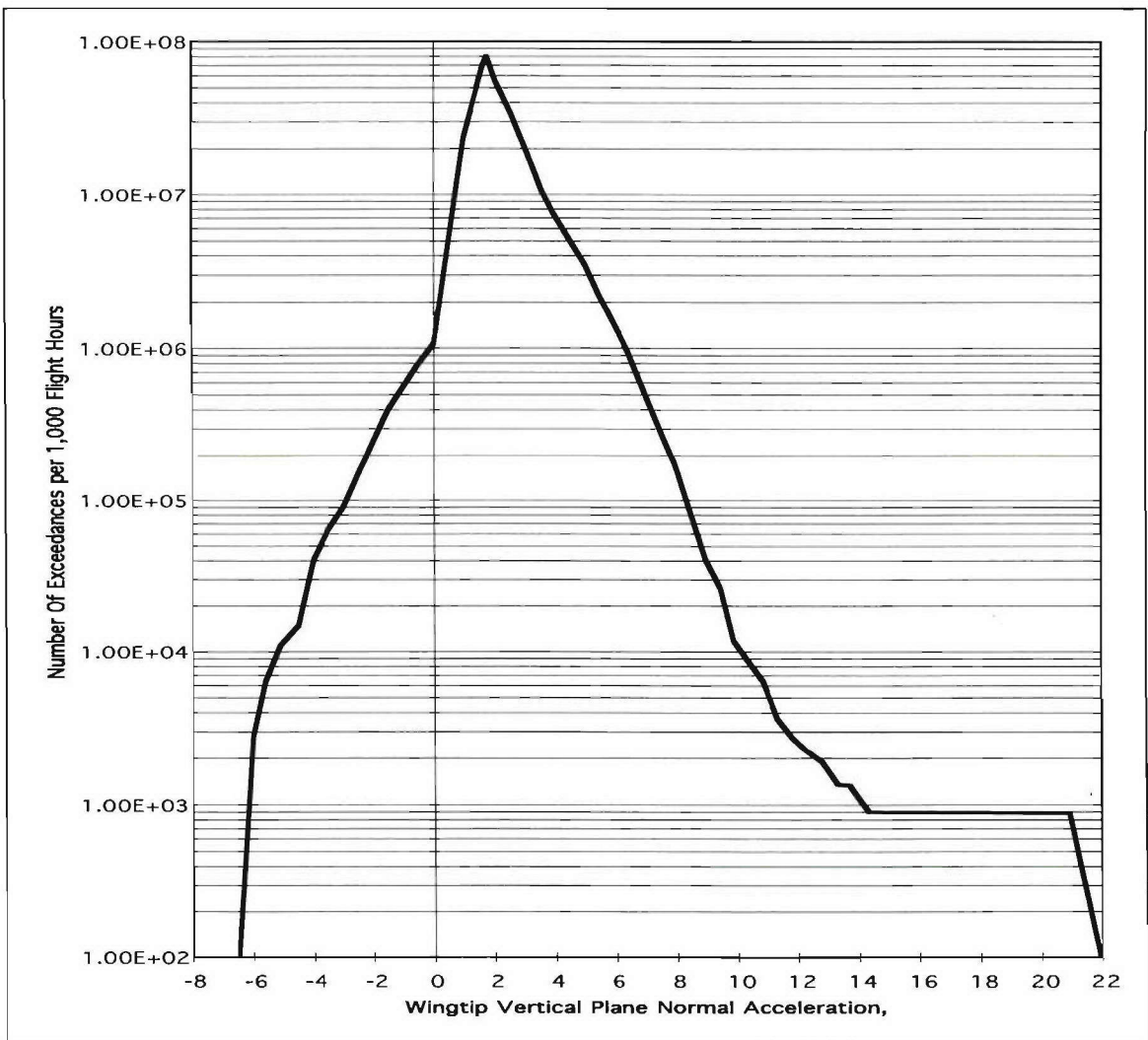

FIGURE P-5. Curve for g Exceedance.

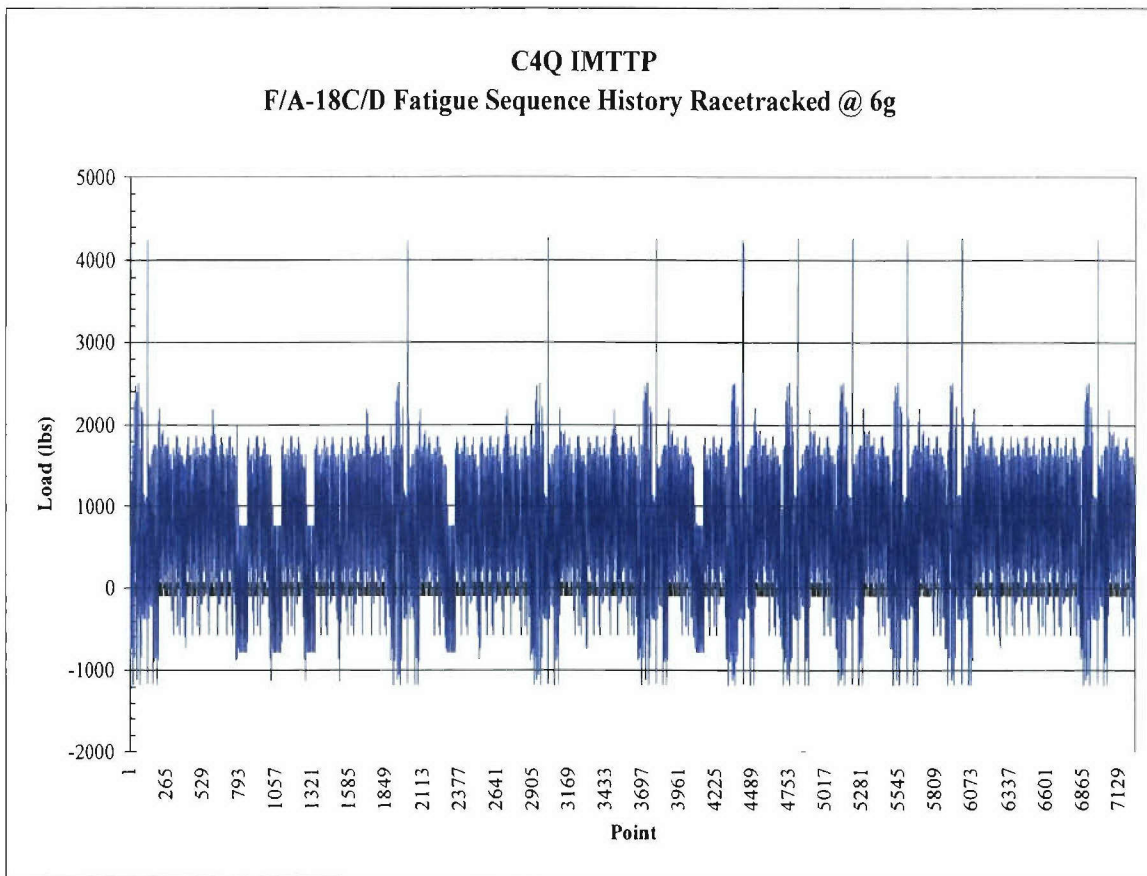

FIGURE P-6. F/A-18C/D Fatigue Sequence.

TEST RESULTS

The test plan is included as Appendix O. It contains the procedures and figures needed to execute the test. The test was performed on 21-29 August 2000. All fixtures and instrumentation performed as expected. The test was run for 600 effective flight hours (EFH), then inspected. It was run for an additional 600 EFH and inspected again. At this point, 18 ft-lb of impact damage were introduced in near the maximum bending moment location and near the wound-in middle hanger (visible damage), and the test was continued for 300 EFH. There were no indications of failure to sustain the fatigue loading sequence. The results are presented below.

INSPECTION METHODS

There were two forms of non-destructive inspection (NDI) used on the C⁴Q blue tube inspections. An overall mapping of anomalies was performed with a Bondmaster, Model TTU-516, part number 1877AS100-1. The probe used with the Bondmaster was the PC-1, part number 1877AS167-1. Both are manufactured by Staveley. Detailed NDI was performed at the high load and hanger areas and any place

the bond master indicated using an ultrasonic inspection system model USN-52; the probe used with it is the "Benchmark Composite Transducer," 2.25-mHz, 0.25-inch-diameter delay line tip. Both are manufactured by Krautkramer. In addition to the NDI, strain data comparisons were made at the beginning and end of each test segment to determine any redistribution of load path or changes in the structural response.

INSPECTION RESULTS AT BEGINNING OF TEST

NDI Results

Pretest NDI mapping showed some small areas (less than 1/4 inch) around the forward and middle hangers with indications of surface disbonds between the Kevlar overwrap and the underlying composite structure. It was uncertain whether the Saran moisture barrier is bonded to the Kevlar layer or the underlying structure. It also showed an area of about 2 inches by 3 inches with a similar Kevlar disbond. This area was a few inches aft of the forward hanger and at about 10:00 (viewed from the front).

Strain Results

Strain data were collected at the start of the test for comparison with later data. Refer to Figure P-7 for the names and locations of the strain gages. The peak applied load in the spectrum was -4272 pounds (-22 g in the aircraft Z direction for wing tip station 1 for a 194-pound round). This load produced the strains provided in Table P-2.

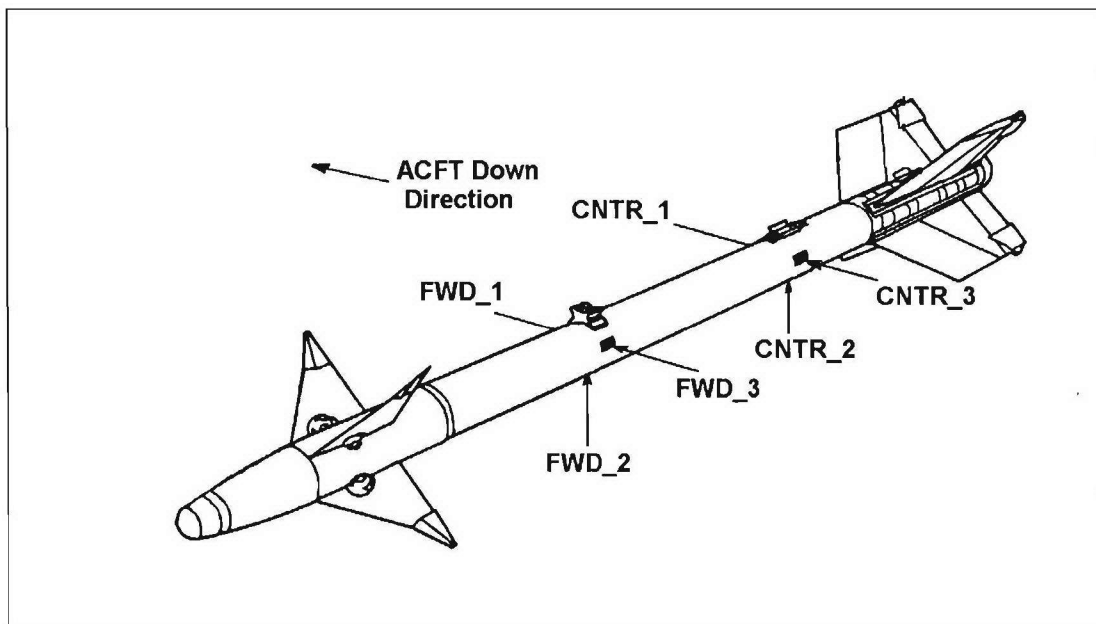

FIGURE P-7. Strain Gage Locations.

TABLE P-2. Strain Snapshot Just After 0 EFH (Microstrain).

	FWD_1	FWD_2	FWD_3	CNTR_1	CNTR_2	CNTR_3
Axial	-552	-138	463	-541	-64	358
Hoop	108	-67	-96	-73	-53	-112
Shear	-244	269	58	-375	-34	228

INSPECTION RESULTS AT 600 EFH

NDI Results

There was an increase in the surface indications at the Kevlar/carbon interface. The indications were point-like occurrences scattered around the area of maximum compression, 90 degrees from the forward hanger. There were no indications of damage in the primary composite structure or the metal hangers and hardware.

Strain Results

The strain data were taken again near the end of the 600 hours, with the results provided in Table P-3 for the same peak cycle. The measured applied load this time was -4263 pounds.

TABLE P-3. Strain Snapshot Just Before 600 EFH (Microstrain).

	FWD_1	FWD_2	FWD_3	CNTR_1	CNTR_2	CNTR_3
Axial	-839	-150	398	-554	-151	239
Hoop	93	-85	-129	-21	-69	-129
Shear	-353	204	58	-362	-123	72

INSPECTION RESULTS AT 1200 EFH

NDI results

There were further increases in the Kevlar disbond indications around both forward and middle hangers and several inches aft of the middle hanger. More significantly, there were small indications (less than 1/4 inch) of discontinuities internal to the primary composite structure approximately 0.075-0.080 inch deep 90 degrees from the forward hanger (maximum compression side) and again at 10 inches aft of that location. There were slightly larger indications (1/4 inch by 1/2 inch) just forward of the middle hanger approximately 0.060 inch deep.

Strain Results

The strain data were taken again near the beginning of the 600- to 1200-hour test period, with the results shown in Table P-4 for the same peak cycle. The measured applied load this time was -4264 pounds.

TABLE P-4. Strain Snapshot Just After 600 EFH (Microstrain).

	FWD_1	FWD_2	FWD_3	CNTR_1	CNTR_2	CNTR_3
Axial	-483	-90	437	-525	-59	351
Hoop	90	-68	-95	-25	-74	-139
Shear	-230	217	-27	-287	-8	155

The strain data were taken again near the end of 1200 hours, with the results shown in Table P-5 for the same peak cycle. The measured applied load this time was -4265 pounds.

TABLE P-5. Strain Snapshot Just Before 1200 EFH (Microstrain).

	FWD_1	FWD_2	FWD_3	CNTR_1	CNTR_2	CNTR_3
Axial	-565	-141	424	-545	-82	323
Hoop	64	-92	-115	-58	-89	-168
Shear	-286	161	-77	-307	-65	126

INSPECTION RESULTS AFTER IMPACT

The fatigue test article was subjected to impact damage at 1200 EFH. NDI mapping of the two impact areas was performed to establish the area of internal damage to the structure. The first location was a few inches aft of the forward hanger 90 degrees around on the side of maximum tension. The area of internal damage (at 0.075-inch depth) was approximately 3.25 inches by 6.0 inches. The second impact location was a few inches in front of the middle hanger on the maximum compression side. The area of damage was approximately 10.0 inches by 1.0 inch. In both cases, the longer dimension was in the hoop direction.

INSPECTION RESULTS AT 1500 EFH

NDI Results

By 1500 EFH, the small indications found at 1200 EFH (0.075-inch depth) had grown to approximately 5/16-inch square. The indications just forward of the middle hanger (0.060-inch depth) had increased to form a line approximately 5 1/2 inches long located 1.25 inches in front of the middle hanger. The forward impact damage area increased from 6 inches long to 7.5 inches long (circumferential growth only), and the aft impact damage area showed no measurable growth.

Strain Results

The strain data were taken again near the end of 1500 hours of testing, with the results shown in Table P-6 for the same peak cycle. The measured applied load this time was -4234 pounds.

TABLE P-6. Strain Snapshot Just Before 1500 EFH (Microstrain).

	FWD_1	FWD_2	FWD_3	CNTR_1	CNTR_2	CNTR_3
Axial	-512	-139	459	-548	-78	343
Hoop	Bad gage	-114	3	-21	-89	-160
Shear	-262	175	45	-351	-40	170

STRAIN RESULTS COMPARISON

The individual strain results are not as useful as the tracking of the strains during the test. Figure P-8 shows the time history of the strain data presented above. Remember that these are all taken from the same maximum peak load in the spectrum and do not show the strain history of the complete loading sequence. This presentation of data shows if there were any major re-distributions of strain over the life of the test. With the exception of a couple of points, the strain history is quite constant as the test progressed.

The exceptions are noteworthy in that the strain variations do not grow in one particular direction, but rather vary above and below some median value. This variation does not, therefore, suggest a steady accumulation of internal damage, but simply variation in the collected data. The worst case (the FWD_1 axial strain), in particular, jumped up at the 600 EFH mark but returned to normal for the remainder of the test.

RESIDUAL STRENGTH

The above strain history and NDI do not indicate significant internal damage (besides at the points of impact damage). But the NDI does show signs of small fatigue-induced damage. The fatigue test article will be saved in order to perform a bending test and a middle hanger test to determine the ability for the tube to sustain loads with this level of fatigue and impact damage.

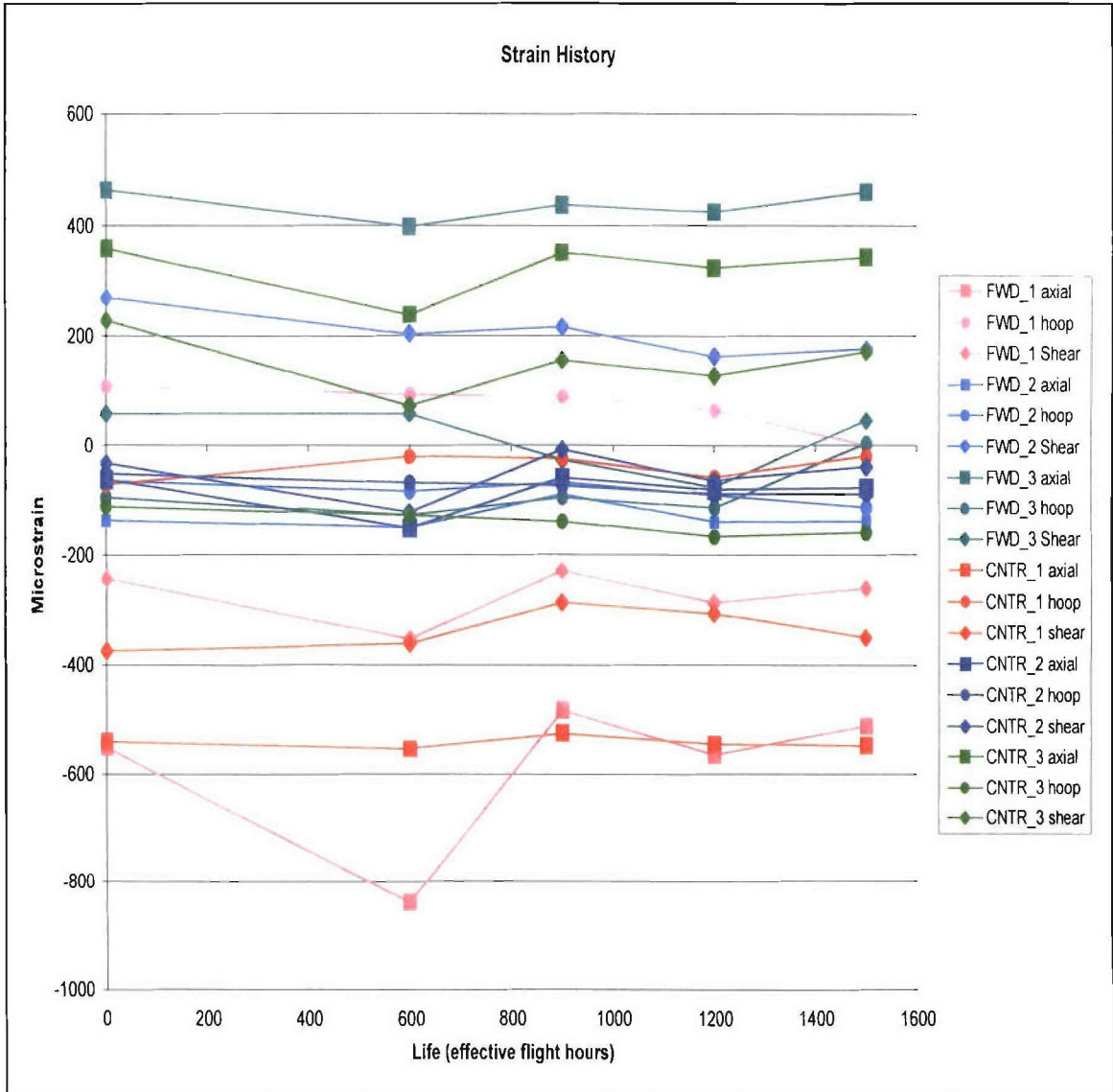

FIGURE P-8. Strain History at Maximum Peak Load.

SUMMARY

As fatigue testing progressed, there were increases in the indications of a disbond between the Kevlar overwrap and the carbon/epoxy structure. This was most likely due to the Saran wrap moisture barrier that is placed over the cured carbon/epoxy and co-cured with the Kevlar overwrap. This barrier appears to weaken the bond of the Kevlar layer. This does not affect the load-carrying capability of the structure.

At 600 EFH, there were no indications of internal damage. Very small damage indications were present at 1200 EFH. A conservative approach would be to establish 600 EFH as the four lifetimes required to verify the composite's fatigue life. This yields a useful fatigue life of 150 flight hours. The very small nature of the damage indications at 1200 EFH suggests that the 300-flight-hour life is possible. But, without a larger substantiating body of test data, it is not advisable to push the C⁴Q blue tube to that limit.

The small fatigue-based internal damage found at 1200 EFH grew slowly from approximately 1/4 inch to 5/16 inch between 1200 and 1500 EFH. This indicates small stable damage growth (1/16 inch over two of the 150-hour recommended lifetimes). This damage size is very much smaller than the already demonstrated impact damage and would not prevent the structure from performing as intended.

There was moderate growth of the large (3.5 inches by 6.0 inches) area of impact damage over the last 300 EFH (two of the 150-hour recommended lifetimes). This indicates stable damage growth with plenty of opportunity to locate the trouble. The impact damage at the more lightly loaded middle hanger did not grow.

The strain data did not show signs of material degradation and redistribution of strain. There was no catastrophic failure under any of the fatigue loads and all appearances indicate a substantial portion, if not all, of the design limit load can still be sustained. A residual strength test can verify that appearance.

Although there was some surface wear, there were no indications of damage to the metal hangers, components, and hardware.

Based on these results, we recommend a 150-hour life limit on the C⁴Q blue tube.

Appendix Q
COMPOSITE CASE CAPTIVE CARRY QUALIFICATION (C⁴Q)
BLUE TUBE VIBRATION TEST PLAN

(This page intentionally left blank.)

1.0 INTRODUCTION

This test plan describes the requirements of the Insensitive Munitions Technology Transition Program (IMTTP) Composite Case Captive Carry Qualification (C⁴Q) composite tube with inert fill all-up-round (AUR) vibration test. The AUR vibration test will subject the test missile to both high-speed dash and buffet vibration with the AUR carried in the wing tip configuration.

2.0 OBJECTIVE

The primary purpose of this test is to verify that design requirements are met. This test plan provides the overall instructions for conducting AUR vibration testing on the composite tube, inert-filled missile with wings and fins.

3.0 TEST DESCRIPTION

This test is intended to demonstrate that the AUR will not fail during exposure to the design captive carriage vibration environment. A total of 12.75 hours of vibration will be applied only in the wing tip vertical direction. Per Reference Q-1, 12.75 hours of test time in the vertical axis is equivalent to 300 hours of vertical axis captive carriage time. The vibration spectra used will be the buffet and straight and level values derived from envelopes of measured data from the F-18, F-15, F-16, and AV-8B and are contained in Reference Q-1. The vibration spectra are based upon measured AIM-9M data. It is assumed that the C⁴Q AUR is dynamically similar to the AIM-9M, which will allow for the use of the data as given. If it is determined that the dynamic responses are significantly different, the test spectra may need to be modified.

The success criteria are as follows. Vibration testing shall be considered successful if the case withstands the applied vibration spectrum without anomalous behavior that would be indicative of its inability to perform its intended use. This shall be determined by inspection (visual and dimensional) and comparison of data with other composite case designs.

3.1 TEST ARTICLE DESCRIPTION

The basic test article is a complete IMTTP C⁴Q (Serial Number 009) body assembly (P/N A476200D-132) assembled into an AUR. The AUR test article consists of the composite motor tube with warhead section, guidance and control section (GCS), wings, fins, and instrumentation pack (see Figure Q-1). (Note: All of the figures are provided at the end of this document.)

3.2 TEST FACILITIES AND EQUIPMENT

The test facility is located at the Code 476300D environmental laboratory. The test equipment includes a Ling B335 shaker with vibration fixture and LAU-7A launcher. Charge amplifiers for the test accelerometers and a vibration controller are also required.

4.0 INSTRUMENTATION AND DATA REQUIREMENTS

The AUR will be instrumented with six accelerometers. The accelerometers will be used for monitoring responses at missile stations 9, 44, and 113. Vertical and lateral response will be monitored at each missile station. The placement of the instrumentation will be as shown in Figure Q-2. Responses at these three locations will be limited so as not to exceed the spectra shown on Figures Q-3 through Q-8. The accelerometer mounted on the fixture will be used for control.

The acceleration power spectral density of the test control signal shall not deviate from the specified requirements by more than ± 3 dB over the test frequency range (10 to 100 Hz). The test data shall be reduced and saved as power spectral density plots. Two copies of all data are required.

5.0 TEST PROCEDURE AND SETUP

The AUR will be tested in accordance with MIL-STD-810, Method 514.4, by using the procedure provided below. The AUR shall be attached to a LAU-7 launcher. The launcher shall be hard-mounted to the shaker. Wings and fins shall be installed. The vibration control accelerometer shall be located on the fixture. Vibration response accelerometers shall be located at missile stations 9, 44, and 113 in the vertical axis and monitoring accelerometers shall be placed in the transverse axis. The vibration response levels will not exceed those shown on Figures Q-3 through Q-8 in the vertical and transverse axes. Note that vibration control will be required in the 10- to 100-Hz band only. Vibration shall be applied for 9.9 hours for high-speed dash and 2.85 hours for buffet (0 dB, 5 minutes; -2.5 dB, 38 minutes; and -6 dB, 128 minutes).

The acceleration response control strategy is as follows. Vibration criteria are specified for specific points on the test item. The control accelerometer is mounted on the vibration fixture. Monitoring accelerometers are mounted at the specified points on the item. An arbitrary low-level vibration, controlled with feedback from the control accelerometer, is input to the test item. The input vibration is experimentally adjusted until the specified levels are achieved at the monitoring accelerometers. This strategy is commonly used with assembled aircraft stores where store response to the dynamic environment is measured or estimated.

5.1 AUR VIBRATION TEST

The composite tube will be placed in an isolated area during the test. Hazardous flying debris is possible and all precautions shall be taken to avoid exposure to the debris. Extreme care should be taken in handling the remains of the case after the test is completed. All tests must comply with all Code 476300D safety requirements.

Vibration will be applied in the aircraft vertical (missile lateral) direction only. Responses in the lateral and vertical axes will be monitored.

1. Perform a visual inspection of the test item.
2. Mount the LAU-7 to the test fixture; then install the AUR power-up GCS if required.
3. Install a control accelerometer on the test fixture to control the vibration exciter as required by the control strategy. Mount response limiting accelerometers at missile stations 9, 44, and 113 in the vertical axis and the monitoring accelerometers in the transverse axis.
4. Conduct a test item vibration survey.
5. Perform a visual inspection of the test item.
6. Apply low-level vibration to the test item/fixture interface.
7. Verify that the vibration exciter, fixture, and instrumentation system function as required.
8. Adjust the vibration exciter such that the test monitor transducers in the excitation axis meet the high-speed dash test requirements defined in Figures Q-3, Q-5, and Q-7. Start with a control accelerometer level of $0.005 g^2/Hz$ from 10 to 100 Hz.
9. Identify the test monitor transducer spectrum peaks that exceed the input spectrum by 6 dB or more (frequencies may differ fore and aft). Equalize the input spectra until the identified peaks equal the required test levels. The resulting input spectra should be as smooth and continuous as possible while achieving the required peak responses. (It is not necessary to fill in valleys in the test monitor transducer spectra; however, it is not acceptable to notch out the input in these valleys.)
10. When the input vibration is adjusted such that the required response (A_1) is achieved, measure the off-axis response (A_2). Verify that off-axis test level is within requirements by using Equation Q-1. If the result is greater than the value indicated, reduce the A_1 value until the equation balances. Apply these equations at each peak separately.

$$2 = (R_1/A_1 + R_2/A_2) \quad (Q-1)$$

where,

R_i = Required level in g^2/Hz

A_i = Actual level in g^2/Hz

11. Apply the required vibration levels to the test item/fixture interface.
12. Verify that the vibration levels at test item/fixture interface are as specified. If the exposure duration is 1/2 hour or less, accomplish this step immediately after full levels are first applied and immediately before scheduled shutdown. Otherwise, accomplish this step immediately after full levels are first applied, every half-hour thereafter, and immediately before scheduled shutdown.
13. Monitor vibration levels continuously through the exposure. If levels shift or a failure occurs, shut down the test. Determine the reason for the shutdown; resume testing if shutdown was not the result of hardware failure.
14. When the required high-speed dash duration of 9.9 hours has been achieved, stop the vibration.

15. Inspect the test item, fixture, vibration exciter, and instrumentation. If failure, wear, looseness, or other anomalies are found, stop testing until it has been determined if the hardware is still suitable for test.
16. Verify that the instrumentation functions as required.
17. Repeat steps 1 through 16 for the -6-dB high-buffet vibration exposure defined in Figures Q-4, Q-6, and Q-8 for a duration of 128 minutes.
18. Repeat steps 1 through 16 for the -2.5-dB high-buffet vibration exposure defined in Figures Q-4, Q-6, and Q-8 for a duration of 38 minutes.
19. Repeat steps 1 through 16 for the 0-dB high-buffet vibration exposure defined in Figures Q-4, Q-6, and Q-8 for a duration of 5 minutes.
20. Remove the test item from the fixture and inspect the test item.

5.2 TEST PRECAUTIONS

All testing must comply with all Code 476300D safety requirements.

5.3 TEST ARTICLE DISPOSITION

The composite tube with inert fill will be post inspected after the vibration test by Code 476J00D personnel. The tube will be delivered to Code 476J00D.

6.0 SUMMARY

Following the test, a summarized report shall be drafted describing the test and the results. Pertinent diagrams and graphs shall be included.

7.0 REFERENCES

- Q-1. Naval Air Warfare Center Weapons Division. *Department of the Navy Document for Sidewinder AIM-9X Environmental Design Criteria and Life Cycle Environmental Profile*. China Lake California, NAWCWD, 29 April 1996. (AS-6132, document UNCLASSIFIED.)

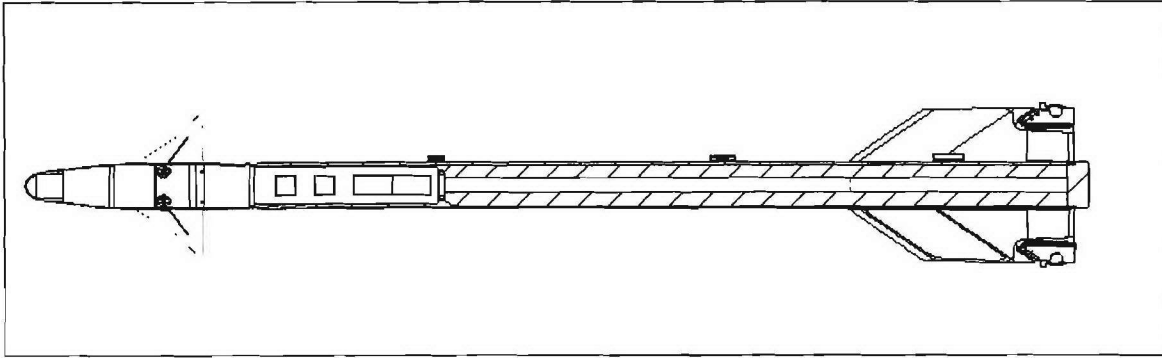

FIGURE Q-1. C⁴Q AUR Test Article.

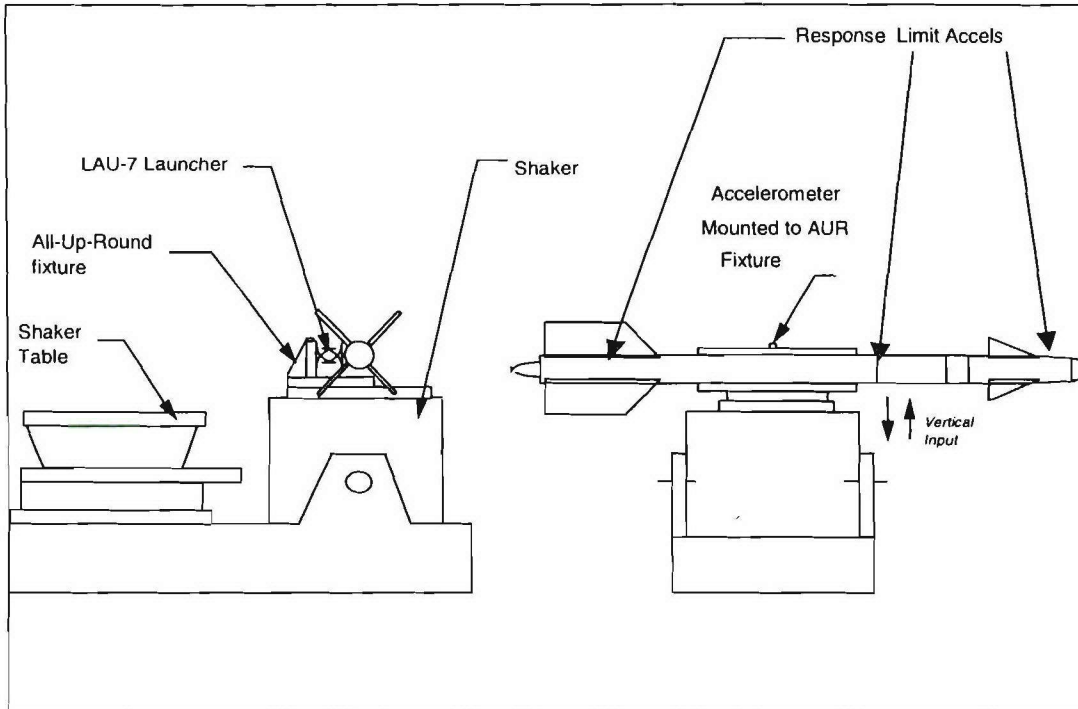
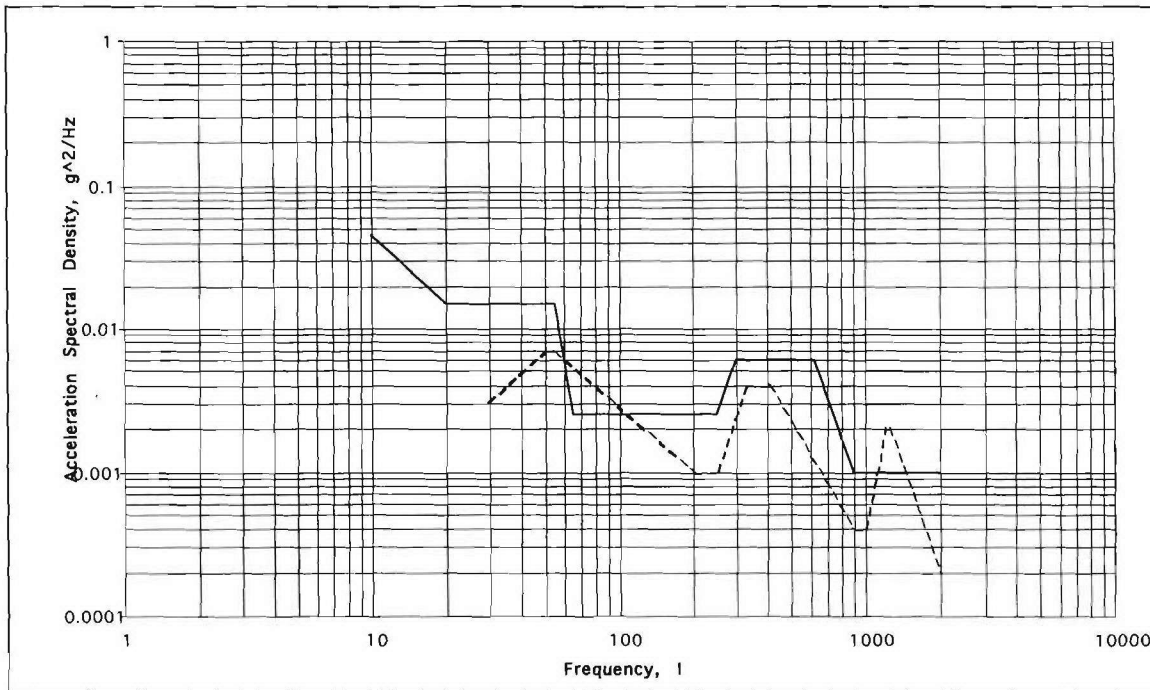

FIGURE Q-2. Vibration Test Setup.



Duration: 9.9 hours

Vertical and Transverse (Solid Line) Longitudinal (Dashed Line)

Frequency, Hz	Vertical and Transverse Plane, g^2/Hz	Frequency, Hz	Longitudinal, g^2/Hz
10	0.045	10	0.003
20	0.015	30	0.003
55	0.015	50	0.007
65	0.0025	55	0.007
250	0.0025	200	0.001
300	0.006	250	0.001
620	0.006	330	0.004
900	0.001	410	0.004
2000	0.001	900	0.0004
overall	$g_{rms} = 2.32$	1000	0.0004
		1200	0.002
		1250	0.002
		2000	0.0002
		overall	$g_{rms} = 1.63$

rms = root mean square.

FIGURE Q-3. Response Limit at GCS (Missile Station 9) During High-speed Dash Vibration.

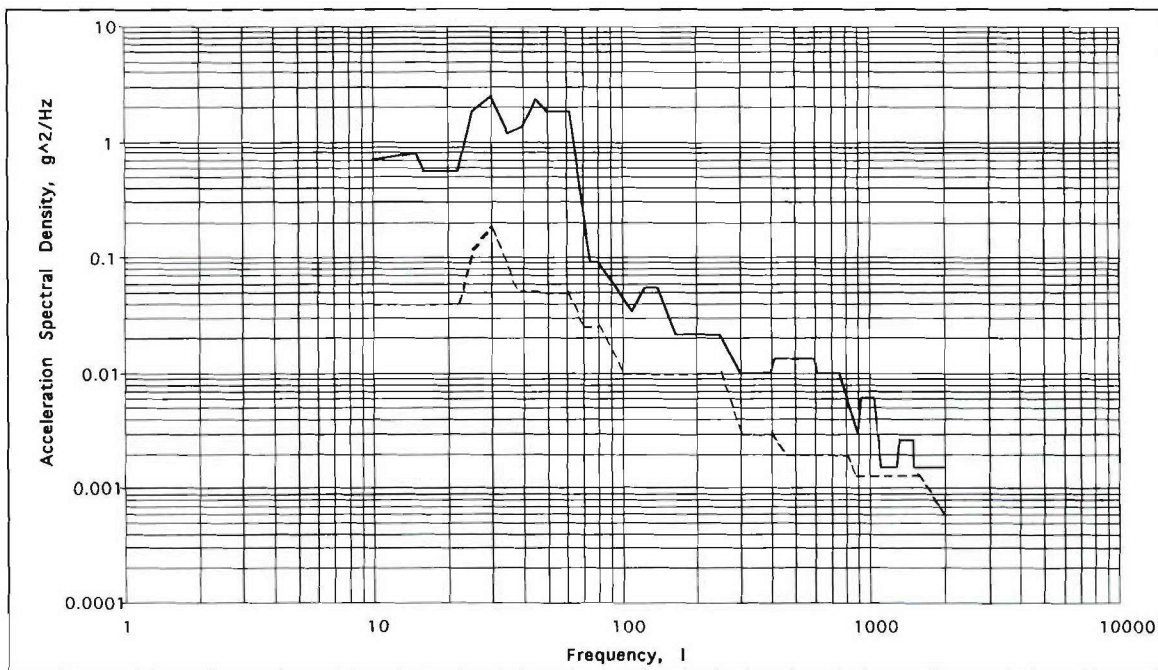

Vertical and Transverse (Solid Line) Longitudinal (Dashed Line)
 0 dB, 5 min/axis
 -2.5 dB, 38 min/axis
 -6.0 dB, 128 min/axis

Frequency, Hz	Vertical and Transverse Plane, g^2/Hz	Frequency, Hz	Vertical and Transverse Plane, g^2/Hz	Frequency, Hz	Longitudinal, g^2/Hz
10	0.704	165	0.021	10	0.04
15	0.78	250	0.021	22	0.04
16	0.55	300	0.01	25	0.116
20	0.55	400	0.01	30	0.175
22	0.55	412	0.013	38	0.051
25	1.81	600	0.013	60	0.05
30	2.43	617	0.01	70	0.025
35	1.17	750	0.01	80	0.025
40	1.35	900	0.003	100	0.01
45	2.35	924	0.006	250	0.01
50	1.8	1050	0.006	300	0.003
62	1.79	1112	0.0015	400	0.003
75	0.092	1288	0.0015	460	0.002
80	0.092	1323	0.0026	800	0.002
111	0.034	1500	0.0026	880	0.0013
125	0.054	1502	0.0015	1565	0.0013
140	0.054	2000	0.0015	2000	0.0006
		overall	$g_{rms} = 10.2$	overall	$g_{rms} = 2.96$

FIGURE Q-4. Response Limit at GCS (Missile Station 9) During Buffet Vibration.

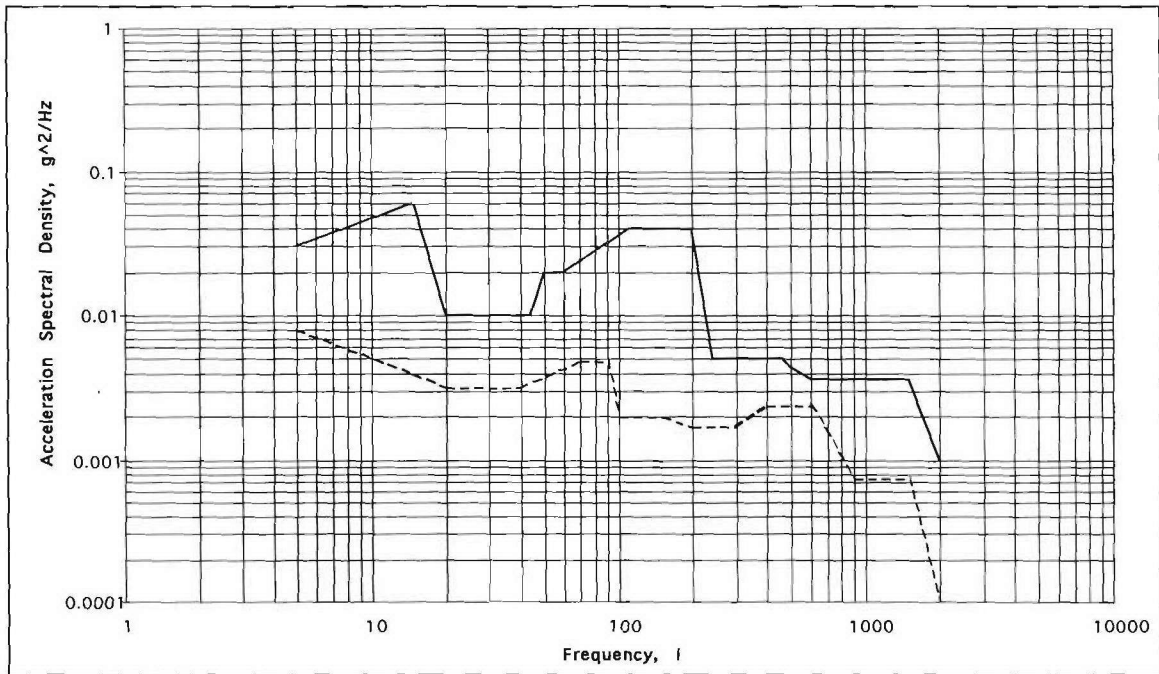

Duration: 9.9 hours

Vertical and Transverse (Solid Line)

Longitudinal (Dashed Line)

Frequency, Hz	Vertical and Transverse Plane, g^2/Hz	Frequency, Hz	Longitudinal, g^2/Hz
10	0.05	10	0.005
15	0.06	15	0.004
20	0.01	20	0.0032
44	0.01	40	0.0032
50	0.02	70	0.0048
60	0.02	90	0.0048
110	0.04	100	0.002
200	0.04	150	0.002
240	0.005	200	0.0017
460	0.005	300	0.0017
500	0.0044	400	0.0024
600	0.0036	600	0.0024
1500	0.0036	900	0.00075
2000	0.001	1500	0.00075
overall	$g_{rms} = 3.59$	2000	0.0001
		overall	$g_{rms} = 1.57$

FIGURE Q-5. Response Limit at Missile Station 43.8 During High-speed Dash Vibration.

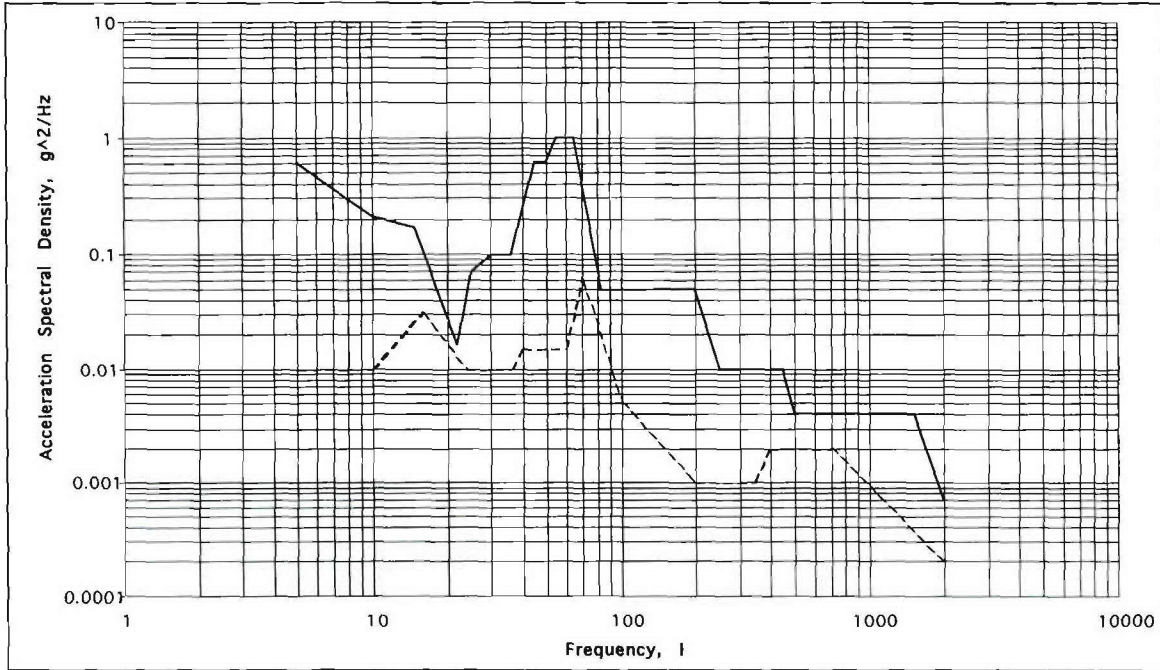

Vertical and Transverse (Solid Line) Longitudinal (Dashed Line)
 0 dB, 5 min/axis
 -2.5 dB, 38 min/axis
 -6.0 dB, 128 min/axis

Frequency, Hz	Vertical and Transverse Plane, g^2/Hz	Frequency, Hz	Vertical and Transverse Plane, g^2/Hz	Frequency, Hz	Longitudinal, g^2/Hz
10	0.21	1525	0.004	10	0.01
15	0.167	2000	0.0007	16	0.03
22	0.016	overall	$g_{rms} = 6.71$	24	0.01
25	0.069			36	0.01
30	0.098			40	0.015
36	0.098			60	0.015
45	0.608			70	0.06
50	0.608			100	0.005
55	0.983			200	0.001
65	0.983			340	0.001
83	0.049			400	0.002
200	0.05			700	0.002
250	0.01			2000	0.0002
450	0.01			overall	$g_{rms} = 1.91$
500	0.004				

FIGURE Q-6. Response Limit at Missile Station 43.8 During Buffet Vibration.

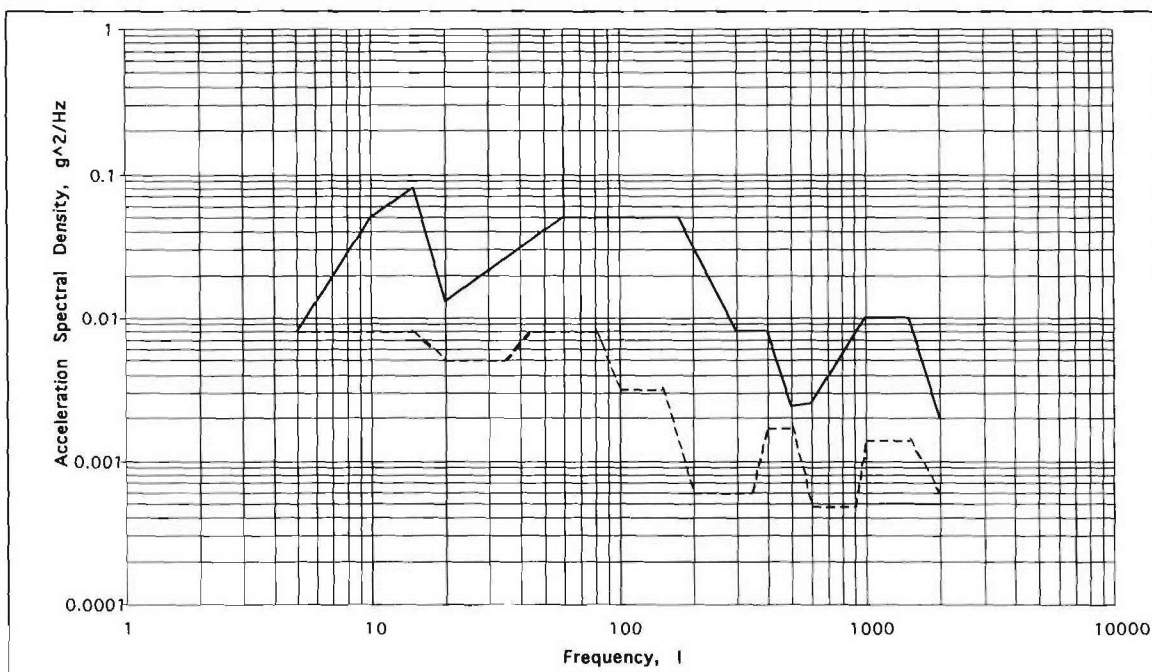

Duration: 9.9 hours

Vertical and Transverse (Solid Line)

Longitudinal (Dashed Line)

Frequency, Hz	Vertical and Transverse Plane, g ² /Hz	Frequency, Hz	Longitudinal, g ² /Hz
10	0.05	15	0.008
15	0.08	20	0.005
20	0.013	35	0.005
60	0.05	45	0.008
175	0.05	80	0.008
300	0.008	100	0.0032
400	0.008	150	0.0032
500	0.0024	200	0.0006
600	0.0025	340	0.0006
1000	0.01	400	0.0017
1500	0.01	500	0.0017
2000	0.002	600	0.00048
overall	$g_{rms} = 4.64$	900	0.00048
		1000	0.0014
		1500	0.0014
		2000	0.0006
		overall	$g_{rms} = 1.64$

FIGURE Q-7. Response Limit at Aft Motor (Missile Station 113) During High-speed Dash Vibration.

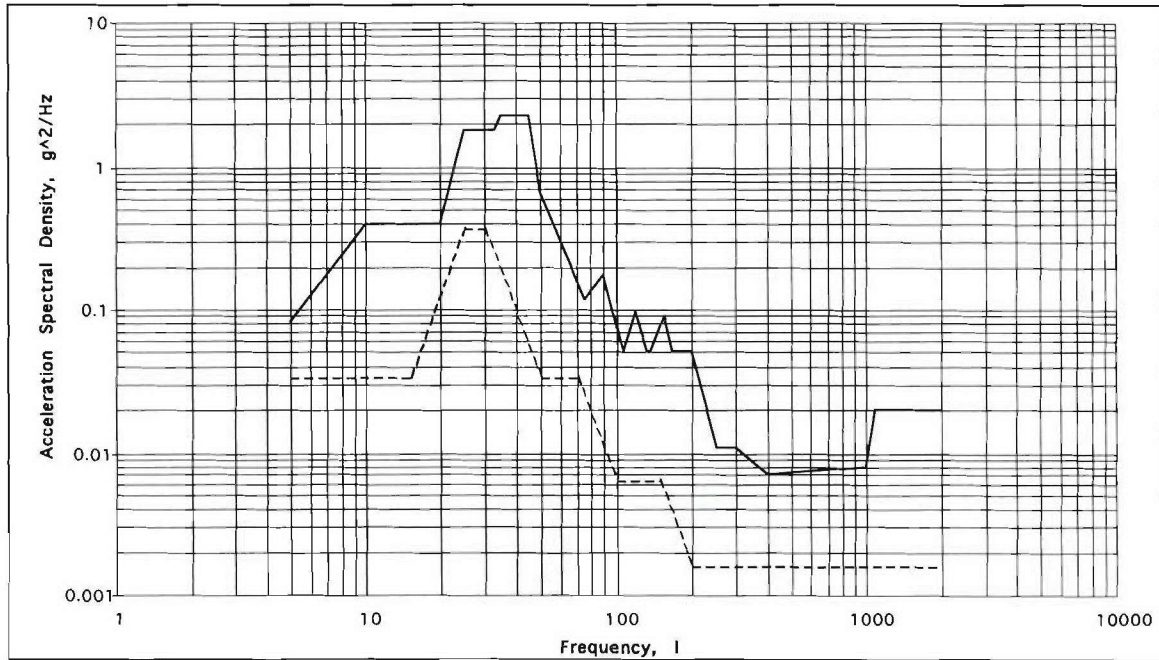

Vertical and Transverse (Solid Line) Longitudinal (Dashed Line)
 0 dB, 5 min/axis
 -2.5 dB, 38 min/axis
 -6.0 dB, 128 min/axis

Frequency, Hz	Vertical and Transverse Plane, g ² /Hz	Frequency, Hz	Vertical and Transverse Plane, g ² /Hz	Frequency, Hz	Longitudinal, g ² /Hz
10	0.393	138	0.051	15	0.034
20	0.401	156	0.091	25	0.37
25	1.8	168	0.052	30	0.37
33	1.8	200	0.051	50	0.034
35	2.27	252	0.011	70	0.034
45	2.27	300	0.011	100	0.0063
50	0.66	400	0.007	150	0.0063
75	0.117	1000	0.008	200	0.0016
90	0.175	1100	0.02	2000	0.0016
106	0.051	2000	0.02	overall	$g_{rms} = 3.32$
120	0.096	overall	$g_{rms} = 10.11$		
133	0.051				

FIGURE Q-8. Response Limit at Aft Motor (Missile Station 113) During Buffet Vibration.

Appendix R
COMPOSITE CASE CAPTIVE CARRY QUALIFICATION (C⁴Q)
BLUE TUBE VIBRATION TEST REPORT

(This page intentionally left blank.)

CONTENTS

Test Description	R-5
Introduction.....	R-5
Test Specimen.....	R-5
Vibration Loading Conditions.....	R-5
Acceleration Response Control Strategy	R-6
Test Results	R-15
Inspection Methods.....	R-15
Inspection Results at Beginning of Test	R-15
Inspection Results at End of Test.....	R-15
Residual Strength.....	R-15
Summary.....	R-16

Figures:

R-1. AUR Structural Layout	R-5
R-2. AUR Attached to LAU-7 Launcher Hard-mounted to Shaker	R-7
R-3. Accelerometer Placement.....	R-8
R-4. Response Limit at Guidance and Control Section (GCS) (Missile Station 9) During High-speed Dash Vibration.....	R-9
R-5. Response Limit at GCS (Missile Station 9) During Buffet Vibration	R-10
R-6. Response Limit Missile Station 43.8 During High-speed Dash Vibration	R-11
R-7. Response Limit at Missile Station 43.8 During Buffet Vibration.....	R-12
R-8. Response Limit at Aft Motor (Missile Station 113) During High-speed Dash Vibration.....	R-13
R-9. Response Limit at Aft Motor (Missile Station 113) During Buffet Vibration.....	R-14
R-10. Grease Pencil Markings	R-16

(This page intentionally left blank.)

TEST DESCRIPTION

INTRODUCTION

The Composite Case Captive Carry Qualification (C⁴Q) blue tube vibration test is a full-scale structural test of the composite blue tube under a captive carriage vibration environment. This test, in combination with other testing, is intended to demonstrate the structural adequacy of the C⁴Q blue tube design. The vibration test article is a full-scale specimen at room temperature and without heat, moisture, or impact damage. The test represents 300 hours of captive carriage at the wing tip stations. After the vibration test, non-destructive inspection (NDI) and a bending ultimate test were performed to verify structural integrity.

TEST SPECIMEN

For reference, Figure R-1 shows the basic structural layout of the CATM-9M with the C⁴Q hardware. The test article is in the all-up-round (AUR) configuration. All components were installed and the test included the on-board data loggers (on and functioning).

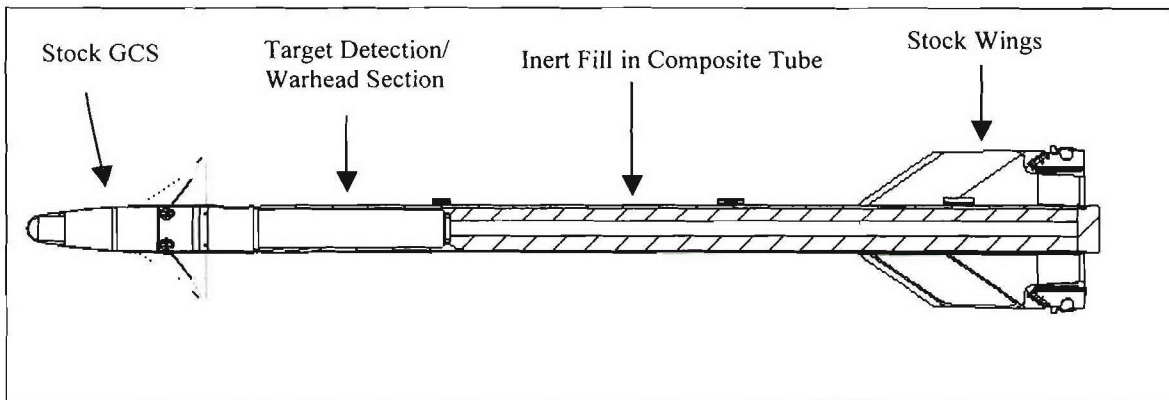

FIGURE R-1. AUR Structural Layout.

VIBRATION LOADING CONDITIONS

The vibration experienced by an AIM-9M on a jet aircraft arises from three distinct sources: aerodynamic boundary layer turbulence, buffet maneuvers, and aircraft-induced vibration.

High-speed dash vibration is due to the structural dynamic response generated by the combination of airflow/airframe interaction (store shape, mounting configuration, and dynamic pressure), in-flight propulsion noise, and aircraft angle of attack, which generate a broadband aerodynamic boundary layer turbulence. The lower frequency portion of the vibration spectrum is generated by buffet maneuvers and aircraft-induced vibration. Buffet vibration is the structural dynamic response to unsteady aerodynamic loading. Buffet occurs primarily on the aircraft wings and is a transient phenomenon. Vibration amplitude

is primarily a function of aircraft angle of attack, free-stream dynamic pressure, and Mach number. Although the vibration levels during high-performance maneuvers can be very intense, typically they do not last for more than 10 seconds, reaching their peak in less than a second and rapidly deteriorating in 5 to 10 seconds. High angle-of-attack flight creates disturbed flow, resulting in high fluctuating pressures on various aircraft surfaces. The fluctuating pressures result in increased vibration levels.

The F-18 and F-15 have typically provided the most severe captive carry environments for the AIM-9. The vibration spectra used for the test consisted of measured data (from the F-18, F-15, F-16, and AV/8) for buffet (combat maneuvers with aircraft N_z at +4 g and above) and high-speed dash (straight and level or non-maneuvering flight), which are equated to 300 hours of captive carriage.

The AUR was tested in accordance with MIL-STD-810, Method 514.4. The AUR was attached to a LAU-7 launcher hard-mounted to the shaker (see Figure R-2). Wings and fins were installed. The vibration control accelerometer was located on the fixture. Vibration response accelerometers were located at missile stations 9, 44, and 113 in the vertical axis and monitoring accelerometers were placed in the transverse axis. See Figure R-3 for accelerometer placement. The vibration response levels were not allowed to exceed those shown on Figures R-4 through R-9 in the vertical and transverse axes. Note that vibration control was required in the 10- to 100-Hz band only. Vibration was applied for 9.9 hours for high-speed dash and 2.85 hours for buffet (0 dB, 5 minutes; -2.5 dB, 38 minutes; and -6 dB, 128 minutes).

ACCELERATION RESPONSE CONTROL STRATEGY

Vibration criteria were specified for specific points on the AUR. The control accelerometer was mounted on the vibration fixture. Monitoring accelerometers are mounted at the specified points on the AUR. An arbitrary low-level vibration, controlled with feedback from the control accelerometer, was input to the test item. The input vibration was experimentally adjusted until the specified levels were achieved within reasonable limits at the monitoring accelerometers. Because the C⁴Q AUR has different dynamic responses than those of an AIM-9M, it is not possible to match exactly the vibration profiles specified. This strategy is commonly used with assembled aircraft stores where store response to the dynamic environment is measured or estimated. Measured response data are shown in Figures R-4 through R-9.

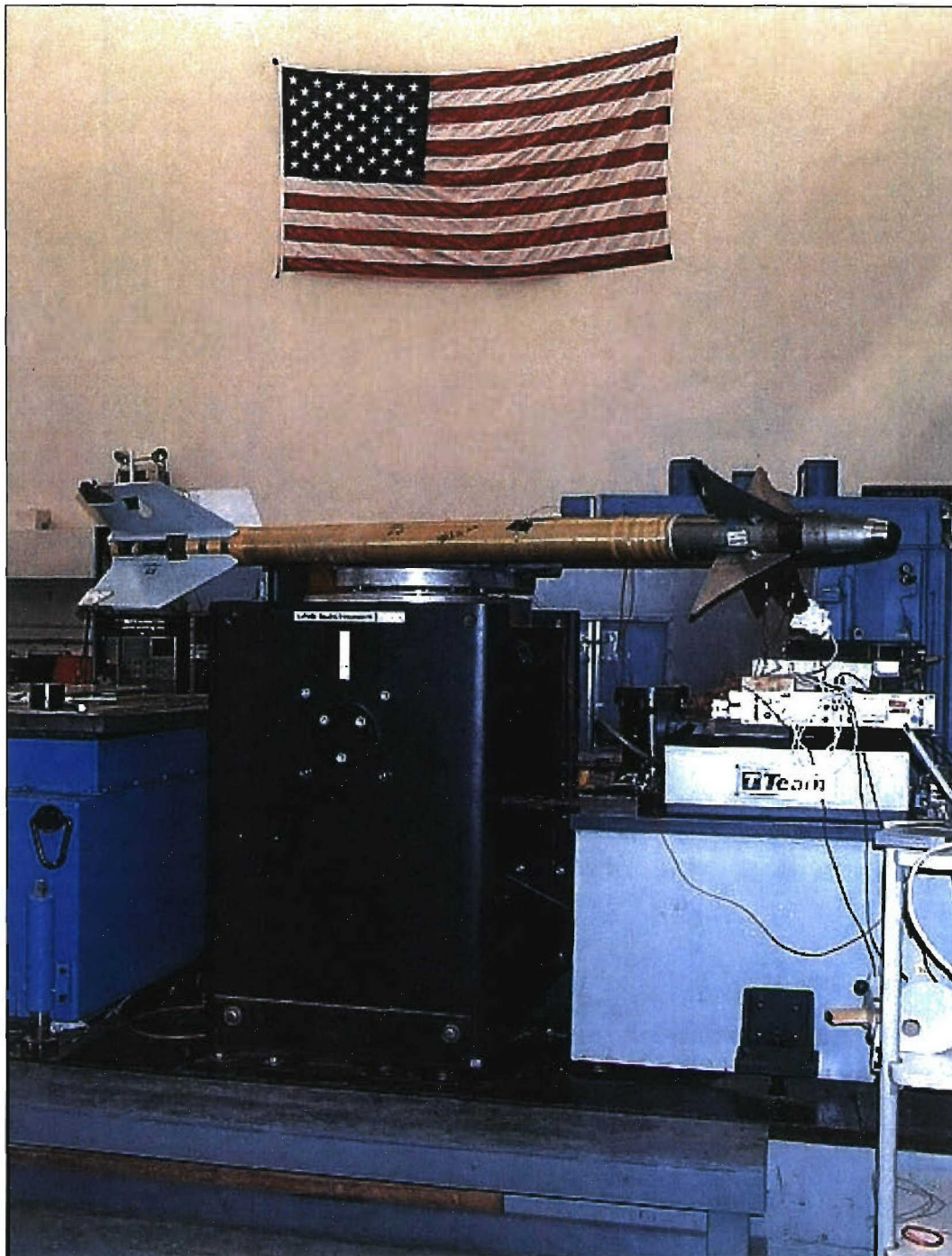
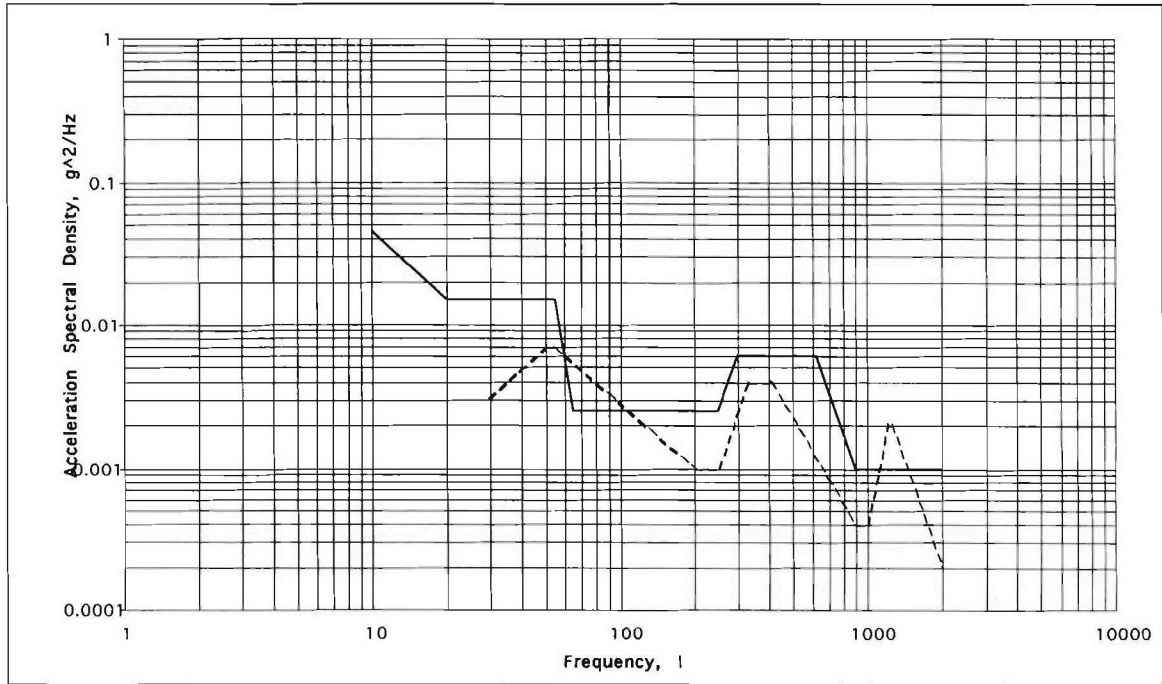

FIGURE R-2. AUR Attached to LAU-7 Launcher Hard-mounted to Shaker.



FIGURE R-3. Accelerometer Placement.



Duration: 9.9 hours

Vertical and Transverse (Solid Line)

Longitudinal (Dashed Line)

Frequency, Hz	Vertical and Transverse Plane, g^2/Hz	Frequency, Hz	Longitudinal, g^2/Hz
10	0.045	10	0.003
20	0.015	30	0.003
55	0.015	50	0.007
65	0.0025	55	0.007
250	0.0025	200	0.001
300	0.006	250	0.001
620	0.006	330	0.004
900	0.001	410	0.004
2000	0.001	900	0.0004
overall	$g_{rms} = 2.32$	1000	0.0004
		1200	0.002
		1250	0.002
		2000	0.0002
		overall	$g_{rms} = 1.63$

rms = root mean square.

FIGURE R-4. Response Limit at Guidance and Control Section (GCS) (Missile Station 9) During High-speed Dash Vibration.

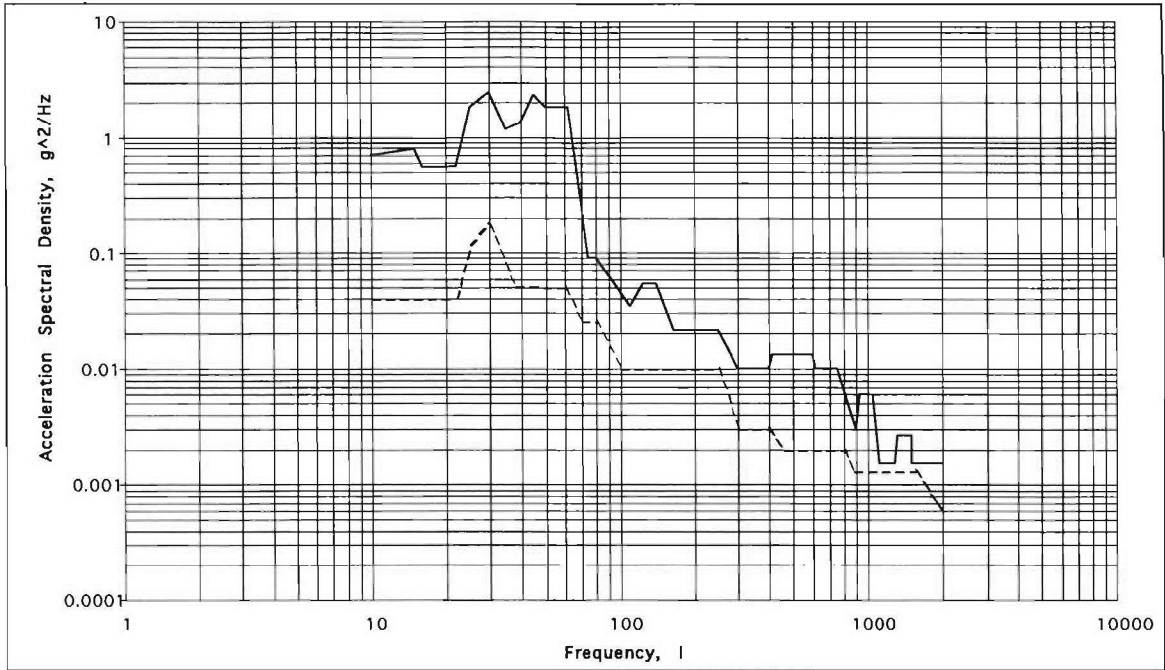

Vertical and Transverse (Solid Line) Longitudinal (Dashed Line)
 0 dB, 5 min/axis
 -2.5 dB, 38 min/axis
 -6.0 dB, 128 min/axis

Frequency, Hz	Vertical and Transverse Plane, g ² /Hz	Frequency, Hz	Vertical and Transverse Plane, g ² /Hz	Frequency, Hz	Longitudinal, g ² /Hz
10	0.704	165	0.021	10	0.04
15	0.78	250	0.021	22	0.04
16	0.55	300	0.01	25	0.116
20	0.55	400	0.01	30	0.175
22	0.55	412	0.013	38	0.051
25	1.81	600	0.013	60	0.05
30	2.43	617	0.01	70	0.025
35	1.17	750	0.01	80	0.025
40	1.35	900	0.003	100	0.01
45	2.35	924	0.006	250	0.01
50	1.8	1050	0.006	300	0.003
62	1.79	1112	0.0015	400	0.003
75	0.092	1288	0.0015	460	0.002
80	0.092	1323	0.0026	800	0.002
111	0.034	1500	0.0026	880	0.0013
125	0.054	1502	0.0015	1565	0.0013
140	0.054	2000	0.0015	2000	0.0006
		overall	$g_{rms} = 10.2$	overall	$g_{rms} = 2.96$

FIGURE R-5. Response Limit at GCS (Missile Station 9) During Buffet Vibration.

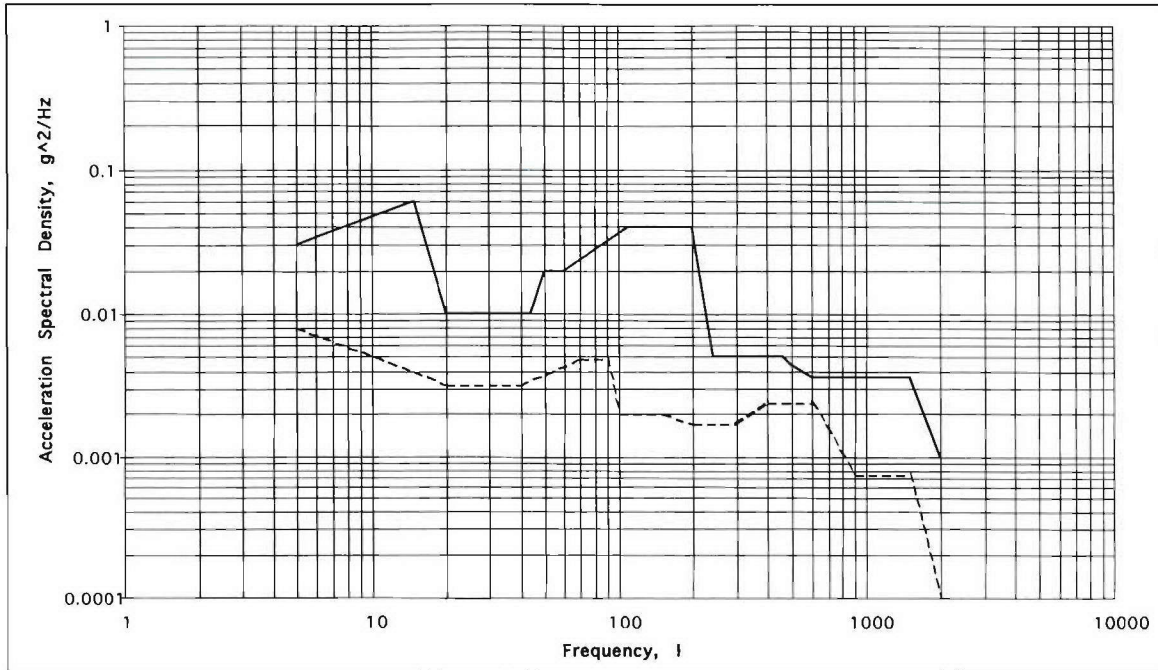

Duration: 9.9 hours

Vertical and Transverse (Solid Line)

Longitudinal (Dashed Line)

Frequency, Hz	Vertical and Transverse Plane, g^2/Hz	Frequency, Hz	Longitudinal, g^2/Hz
10	0.05	10	0.005
15	0.06	15	0.004
20	0.01	20	0.0032
44	0.01	40	0.0032
50	0.02	70	0.0048
60	0.02	90	0.0048
110	0.04	100	0.002
200	0.04	150	0.002
240	0.005	200	0.0017
460	0.005	300	0.0017
500	0.0044	400	0.0024
600	0.0036	600	0.0024
1500	0.0036	900	0.00075
2000	0.001	1500	0.00075
overall	$g_{rms} = 3.59$	2000	0.0001
		overall	$g_{rms} = 1.57$

FIGURE R-6. Response Limit at Missile Station 43.8 During High-speed Dash Vibration.

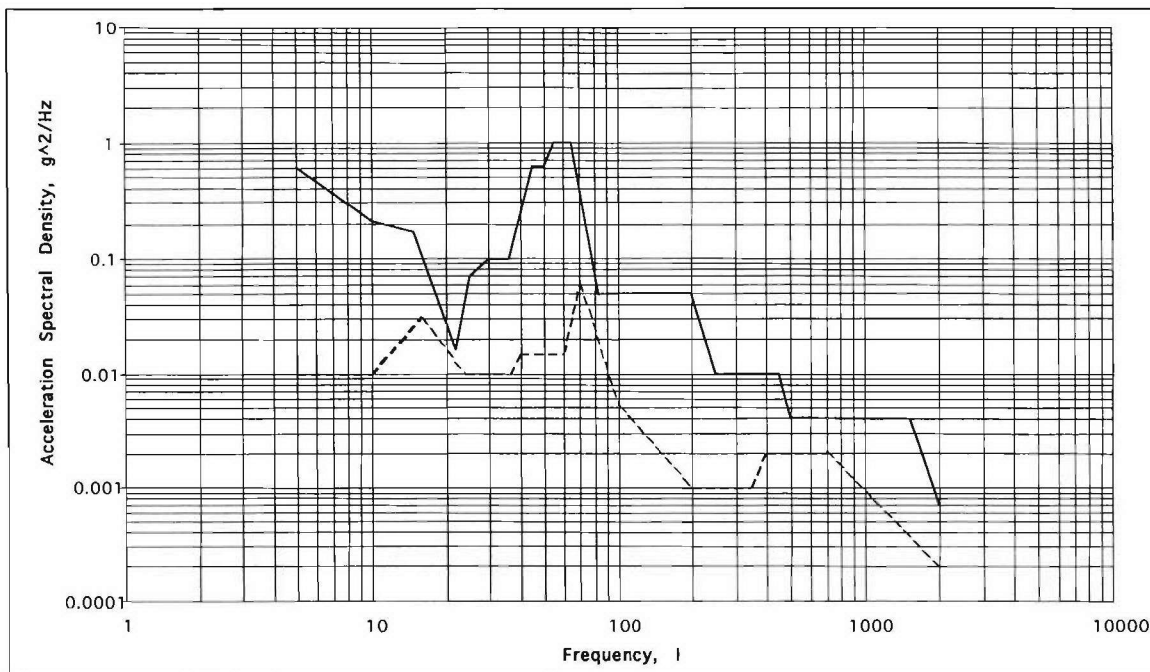

Vertical and Transverse (Solid Line) Longitudinal (Dashed Line)

0 dB, 5 min/axis
 -2.5 dB, 38 min/axis
 -6.0 dB, 128 min/axis

Frequency, Hz	Vertical and Transverse Plane, g ² /Hz	Frequency, Hz	Vertical and Transverse Plane, g ² /Hz	Frequency, Hz	Longitudinal, g ² /Hz
10	0.21	1525	0.004	10	0.01
15	0.167	2000	0.0007	16	0.03
22	0.016	overall	$g_{rms} = 6.71$	24	0.01
25	0.069			36	0.01
30	0.098			40	0.015
36	0.098			60	0.015
45	0.608			70	0.06
50	0.608			100	0.005
55	0.983			200	0.001
65	0.983			340	0.001
83	0.049			400	0.002
200	0.05			700	0.002
250	0.01			2000	0.0002
450	0.01			overall	$g_{rms} = 1.91$
500	0.004				

FIGURE R-7. Response Limit at Missile Station 43.8 During Buffet Vibration.

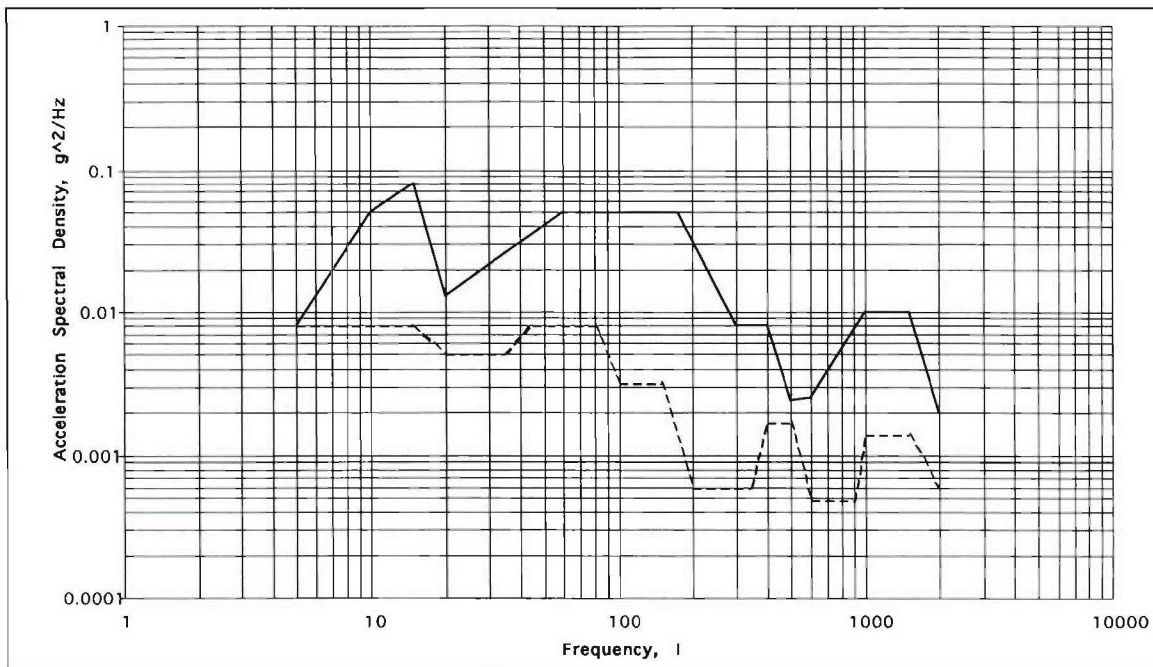

Duration: 9.9 hours

Vertical and Transverse (Solid Line)

Longitudinal (Dashed Line)

Frequency, Hz	Vertical and Transverse Plane, g^2/Hz	Frequency, Hz	Longitudinal, g^2/Hz
10	0.05	15	0.008
15	0.08	20	0.005
20	0.013	35	0.005
60	0.05	45	0.008
175	0.05	80	0.008
300	0.008	100	0.0032
400	0.008	150	0.0032
500	0.0024	200	0.0006
600	0.0025	340	0.0006
1000	0.01	400	0.0017
1500	0.01	500	0.0017
2000	0.002	600	0.00048
overall	$g_{rms} = 4.64$	900	0.00048
		1000	0.0014
		1500	0.0014
		2000	0.0006
		overall	$g_{rms} = 1.64$

FIGURE R-8. Response Limit at Aft Motor (Missile Station 113) During High-speed Dash Vibration.

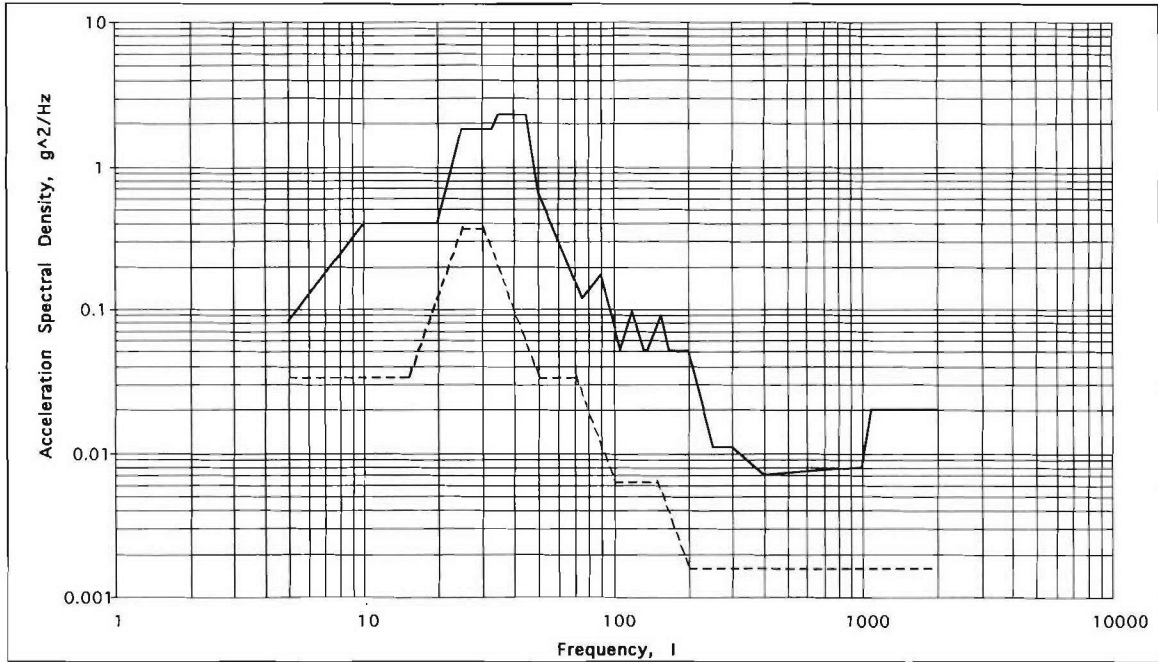

Vertical and Transverse (Solid Line) Longitudinal (Dashed Line)

0 dB, 5 min/axis
 -2.5 dB, 38 min/axis
 -6.0 dB, 128 min/axis

Frequency, Hz	Vertical and Transverse Plane, g^2/Hz	Frequency, Hz	Vertical and Transverse Plane, g^2/Hz	Frequency, Hz	Longitudinal, g^2/Hz
10	0.393	138	0.051	15	0.034
20	0.401	156	0.091	25	0.37
25	1.8	168	0.052	30	0.37
33	1.8	200	0.051	50	0.034
35	2.27	252	0.011	70	0.034
45	2.27	300	0.011	100	0.0063
50	0.66	400	0.007	150	0.0063
75	0.117	1000	0.008	200	0.0016
90	0.175	1100	0.02	2000	0.0016
106	0.051	2000	0.02	overall	$g_{rms} = 3.32$
120	0.096	overall	$g_{rms} = 10.11$		
133	0.051				

FIGURE R-9. Response Limit at Aft Motor (Missile Station 113) During Buffet Vibration.

TEST RESULTS

The test plan is included as Appendix Q. It contains the procedures and figures needed to execute the test. The test was performed on 29 August 2000. All fixtures and instrumentation performed as expected. The test was run for 300 effective flight hours and then inspected. The results are presented below.

INSPECTION METHODS

There were two forms of NDI used on the C⁴Q blue tube inspections. An overall mapping of anomalies was performed with a Bondmaster, Model TTU-516, part number 1877AS100-1. The probe used with the Bondmaster was the PC-1, part number 1877AS167-1. Both are manufactured by Staveley. Detailed NDI was performed at the high load and hanger areas and any place that the bond master indicated by using an ultrasonic inspection system Model USN-52; the probe used with it is the "Benchmark Composite Transducer," 2.25-mHz, 0.25-inch-diameter delay line tip. Both are manufactured by Krautkramer. NDI was performed at the beginning and end of the vibration test segment to determine changes in indications due to the vibration environment.

INSPECTION RESULTS AT BEGINNING OF TEST

Pretest NDI mapping showed some small areas (less than 1/4 inch) around the forward and middle hangers with indications of surface disbonds between the Kevlar overwrap and the underlying composite structure. It was uncertain whether the Saran moisture barrier is bonded to the Kevlar layer or the underlying structure.

INSPECTION RESULTS AT END OF TEST

Post-test NDI mapping showed an increase in the number of locations indicating small internal indications at depths between 0.060 inch and 0.080 inch. In addition, there were numerous indications in the hoop direction near the forward hanger. They are most pronounced just aft of the forward hanger at the aft edge of the internal wound-in warhead section. See Figure R-10 to see the grease pencil markings from NDI in that area.

RESIDUAL STRENGTH

The NDI results do not indicate significant internal damage. But, they do show areas that are probably vibration-induced internal damage. The vibration test article was subjected to a three-point bending test. This test is the same as specified in the C⁴Q bending test report. That test is described in Appendix S. The results of that test were a positive margin of safety of +0.54 with a factor of safety of 1.5 and load increases to cover hot/wet and impact damage material knockdown factors.

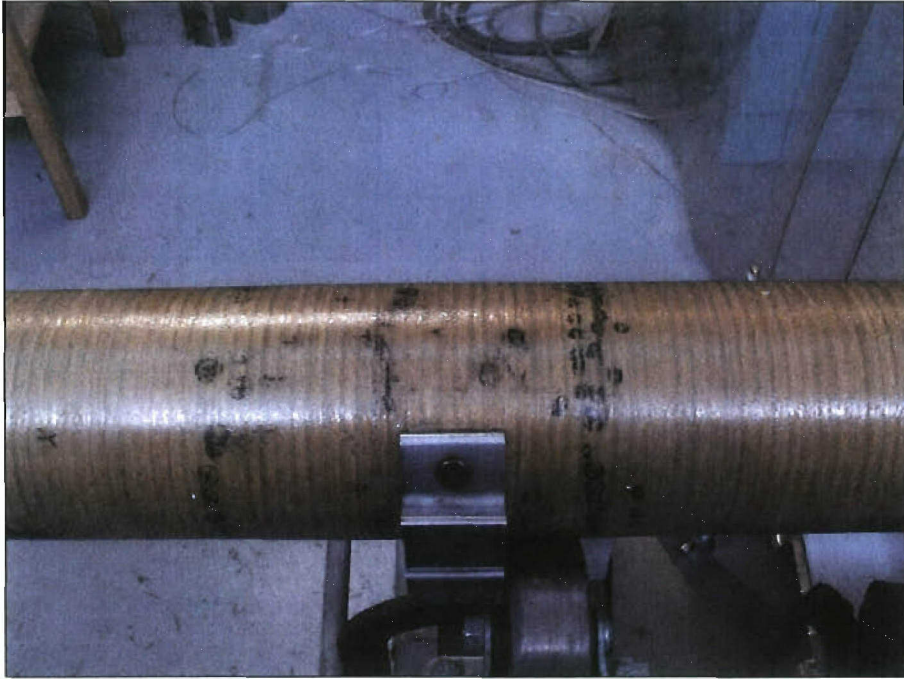

FIGURE R-10. Grease Pencil Markings.

SUMMARY

In this test, the C⁴Q composite blue tube was subjected to the captive carriage vibration environment for an equivalent of 300 flight hours. There were NDI indications of discontinuities about 0.060-0.080 inch in depth that were approximately 1/4-inch square in size but grouped closely together near the area of maximum bending stress. Subsequent bending ultimate test to failure showed a positive margin of +0.54 with a factor of safety of 1.5 and increases in load to cover the material knockdowns for hot/wet and impact damage.

Appendix S
COMPOSITE CASE CAPTIVE CARRY QUALIFICATION (C⁴Q)
BLUE TUBE BENDING AFTER VIBRATION TEST REPORT

(This page intentionally left blank.)

CONTENTS

Test Description	S-5
Introduction.....	S-5
Test Specimen.....	S-5
Loading Condition.....	S-6
Analysis of Loading.....	S-7
Three-point Bending Development.....	S-7
Analysis of Structural Response	S-8
Test Results	S-8
Yield Test.....	S-9
Ultimate Test.....	S-11
Summary.....	S-13

 Figures:

S-1. NDI Indications After Vibration.....	S-5
S-2. Bending After Vibration Test Fixture	S-6
S-3. Bending Test Moment Diagram	S-7
S-4. Test Load History.....	S-9
S-5. Compressive Axial Strain at Forward Hanger	S-10
S-6. Compressive Axial Strain at Worst NDI Indications.....	S-10
S-7. Strain Data at Forward Hanger (Ultimate Loading)	S-11
S-8. Strain Data at Aft Edge of Warhead Section (Ultimate Loading).....	S-12
S-9. Ultimate Failure Location (View 1)	S-12
S-10. Ultimate Failure Location (View 2)	S-13

 Tables:

S-1. Predicted Structural Response	S-8
--	-----

(This page intentionally left blank.)

TEST DESCRIPTION

INTRODUCTION

The Composite Case Captive Carry Qualification (C⁴Q) blue tube bending after vibration is a full-scale structural test of the composite blue tube in bending. The goal was to simulate the worst-case bending load on the missile body. This test, in combination with other testing, is intended to demonstrate the structural adequacy of the C⁴Q blue tube design. This test was performed on a full-scale specimen at room temperature and without heat, moisture, or impact damage. The test article was subjected to a full lifetime of vibration prior to this test. The non-destructive inspection (NDI) results showed indications of some internal discontinuities near the forward hanger after the vibration testing. The test yielded a margin of safety (M.S.) for bending of the tube of +0.54. This was with a 1.5 ultimate factor of safety with increased load requirements for the knockdown factors of 1.25 for hot/wet and 1.25 for impact damage.

TEST SPECIMEN

The vibration test article was an all-up round. After the vibration testing, the round was disassembled and converted to a bending test article. The test article omits the guidance and control section (GCS), wings, fins, and hangers. The inert fill was left in place. None of these items were considered significant for this test. The forward hanger bolt holes were enlarged and a locating pin hole was added per the instructions in the test plan. This allowed sufficient load to be applied to the composite case for it to fail in the composite section without failing at the forward hanger or spinning in the fixture. The NDI indications of some vibration-induced internal discontinuities near the forward hanger are shown in Figure S-1. These indications were approximately 0.060 inch beneath the surface. They are most pronounced at the aft edge of the warhead section just behind the forward hanger.

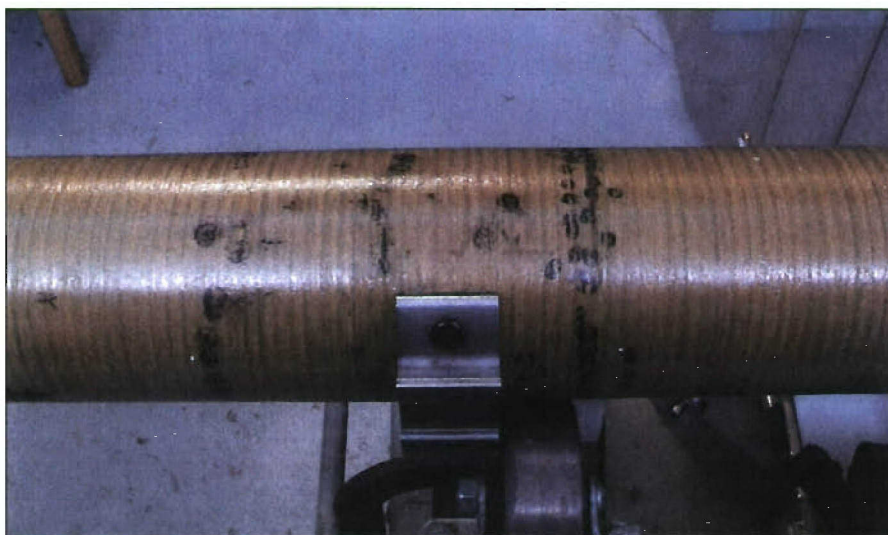

FIGURE S-1. NDI Indications After Vibration.

LOADING CONDITION

The specimen was loaded in a three-point bending fixture. The locations of the end clamping fixtures and load application point were designed to approximate the moment diagram during the worst-case bending maneuver (the Mk 84 bomb release). A block-like replacement for the forward hanger was used to simulate the load transfer through the forward hanger. This reduced the risk of forward hanger failure to prevent an invalid test and wasted specimen. The loading was raised to yield level and returned to zero in order to confirm that no permanent deformation occurred. The loading was then raised until it produced failure. The fixtures and loading sequence can be seen in detail in the test plan (Appendix A) and in Figure S-2.

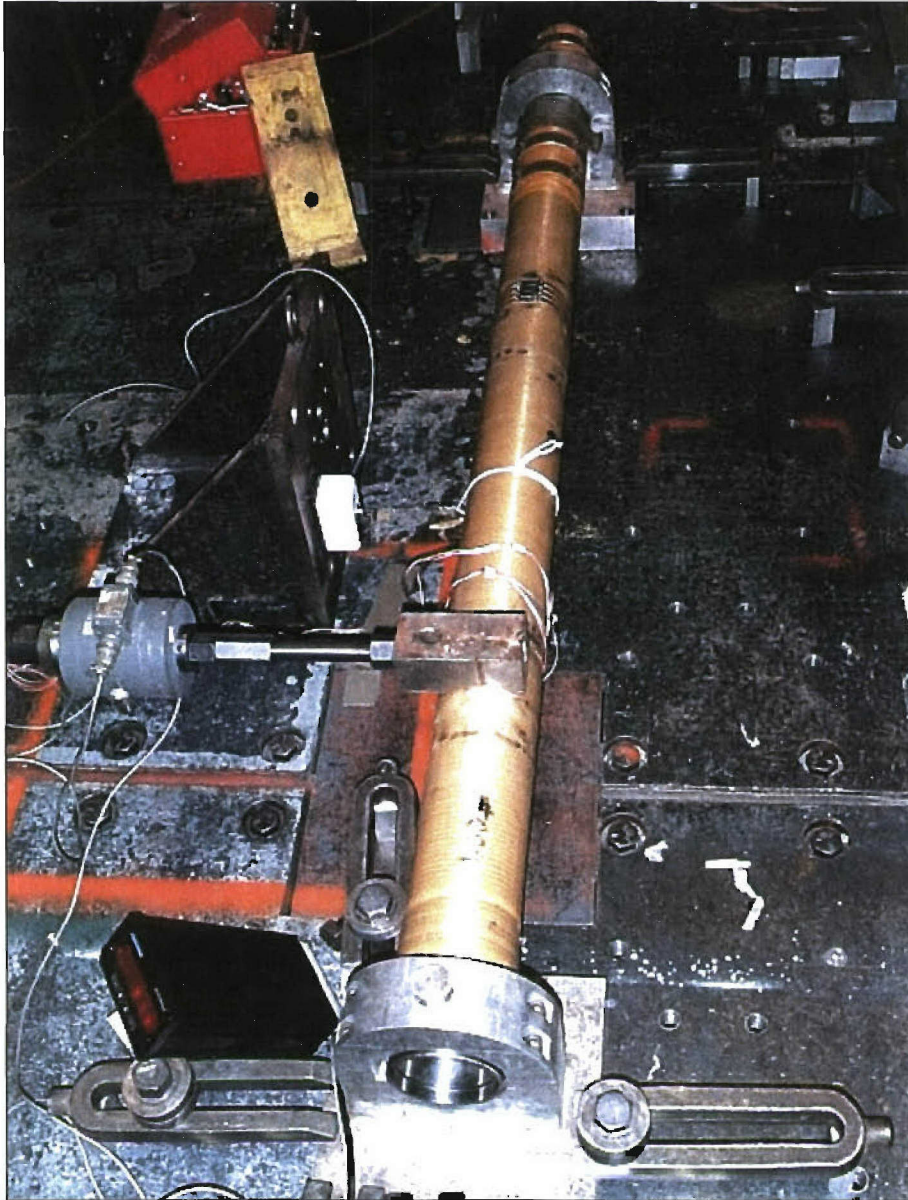

FIGURE S-2. Bending After Vibration Test Fixture.

ANALYSIS OF LOADING

THREE-POINT BENDING DEVELOPMENT

The development of the three-point bending fixture and loading values is based on the assumption that the composite tube will fail at or near the forward hanger where the bending moment is most severe. The assumption of simple supports is used due to the geometry of the clamps and the clearance with the tube. The clamp locations were estimated by fitting a triangular moment diagram (typical for three-point bending) onto the maximum moment envelope. The peak at the forward hanger is for the Mk 84 release condition (worst-case limit load). Figure S-3 shows the results. Note that the locations of the base corners of the triangle correspond to the clamping locations.

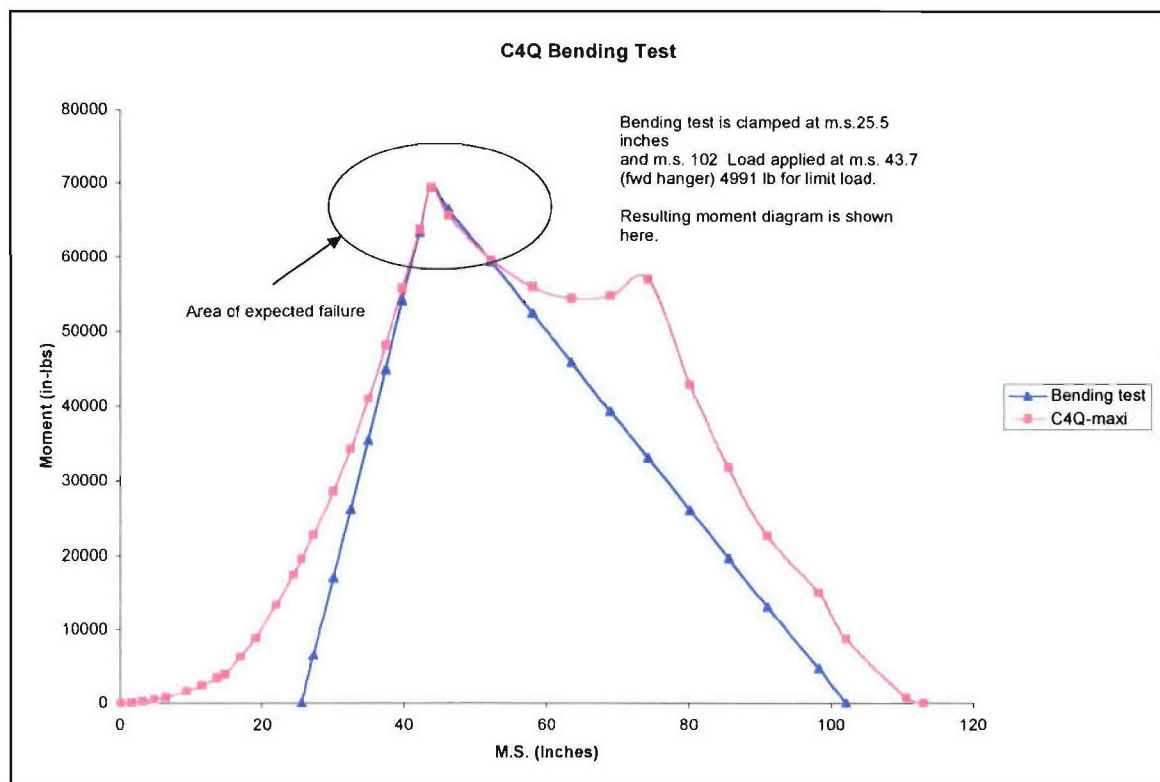

FIGURE S-3. Bending Test Moment Diagram.

The magnitude of the needed applied load was determined by working backward from the triangular moment diagram.

The shear in front of the load is equal to moment divided by the distance from front clamp to load ($[69,200 \text{ in-lb}]/[18.2 \text{ inches}] = 3800 \text{ pounds}$). The shear behind the load is equal to negative moment divided by the distance from load to the back clamp ($-[69,200 \text{ in-lb}]/[58.3 \text{ inches}] = -1190 \text{ pounds}$). The

total applied load is 4990 pounds (3800 pounds + 1190 pounds). This value is for the AIM-9M limit load condition. Therefore, Equations S-1 and S-2 apply.

$$\text{Yield Load} = 4990 \times 1.15 = 5738 \text{ pounds} \quad (\text{S-1})$$

$$\text{Ultimate Load} = 4990 \times 1.50 = 7485 \text{ pounds} \quad (\text{S-2})$$

The composite materials have knockdown factors to cover the degradation due to impact damage and hot/wet operating environments. The knockdown factors are 1.25 for impact and 1.25 for hot/wet. Because bending test 1 does not pre-condition the composite to those reduced strengths, the test loads must be higher to demonstrate the adequacy of the tube. Later tests will demonstrate the tube under these adverse conditions. Equations S-3 and S-4 apply.

$$\text{Composite Yield Load} = 5738 \text{ pounds} \times 1.25 \times 1.25 = 8960 \text{ pounds} \quad (\text{S-3})$$

$$\text{Composite Ultimate Load} = 7485 \text{ pounds} \times 1.25 \times 1.25 = 11,700 \text{ pounds} \quad (\text{S-4})$$

This is the same loading arrangement used in the room temperature, dry, undamaged bending test 1 (Appendixes A and B).

ANALYSIS OF STRUCTURAL RESPONSE

The analysis and predicted structural response are the same as written in the bending test 1 report (Appendix B) and are not repeated here. The resulting predictions are included as Table S-1 for reference.

TABLE S-1. Predicted Structural Response.

Level	Load, lb	Moment, in-lb	Stress, ksi	Strain, in/inE-6	Deflection, in
Instrument test	1,000	13,900	4.27	-241	0.044
Limit load	4,990	69,200	21.3	-1200	0.220
Yield load	5,740	79,600	24.5	-1380	0.250
Ultimate load	7,480	103,700	31.9	-1800	0.327
Composite yield load	8,960	124,000	38.2	-2160	0.391
Composite ultimate load	11,700	162,000	49.9	-2820	0.510
Predicted failure	14,300	198,000	61.1	-3450	0.623

TEST RESULTS

The test plan followed was the bending test 1 plan (Appendix A), with the exception of not requiring steps in the load history. These were no longer deemed necessary as the data acquisition system has proven able to keep up with these lower loading rates. The test was performed on 10 October 2000. All fixtures and instrumentation performed as expected. The test was performed in two stages. The first stage was to increase the load to the "composite yield load" and back down to zero. The second stage was to increase the load to failure. The load history recorded during the test is presented in Figure S-4.

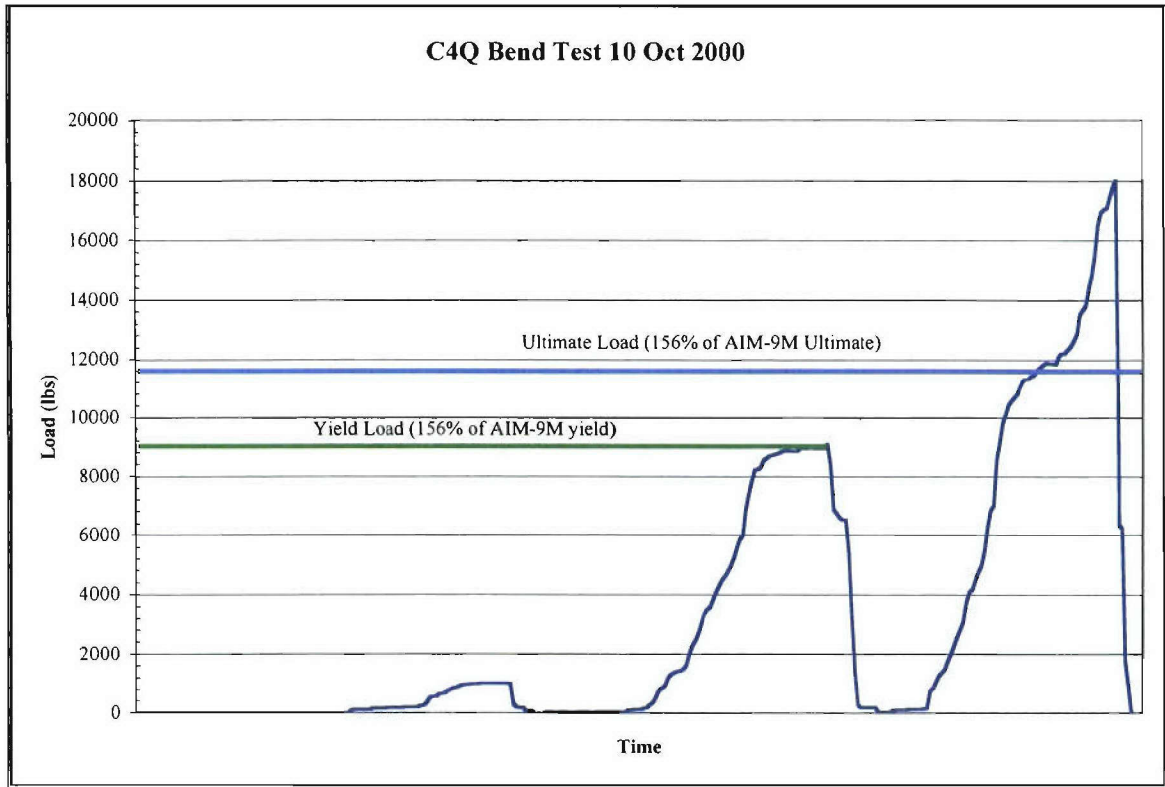

FIGURE S-4. Test Load History.

YIELD TEST

The predictions of compressive strain at the forward hanger were still very close to the predicted values (see Figures S-5 and S-6). The comparison suggests a slight decrease in the effective modulus of the composite tube. This effect is more pronounced in the area of the most severe NDI indications. The strain data for unloading after "yield" load are included and show relatively good return to the original strains after unloading. The strain returns fairly closely to the original path during loading. Therefore, the C⁴Q composite tube passed yield test after vibration with the loads increased to cover the material knockdowns.

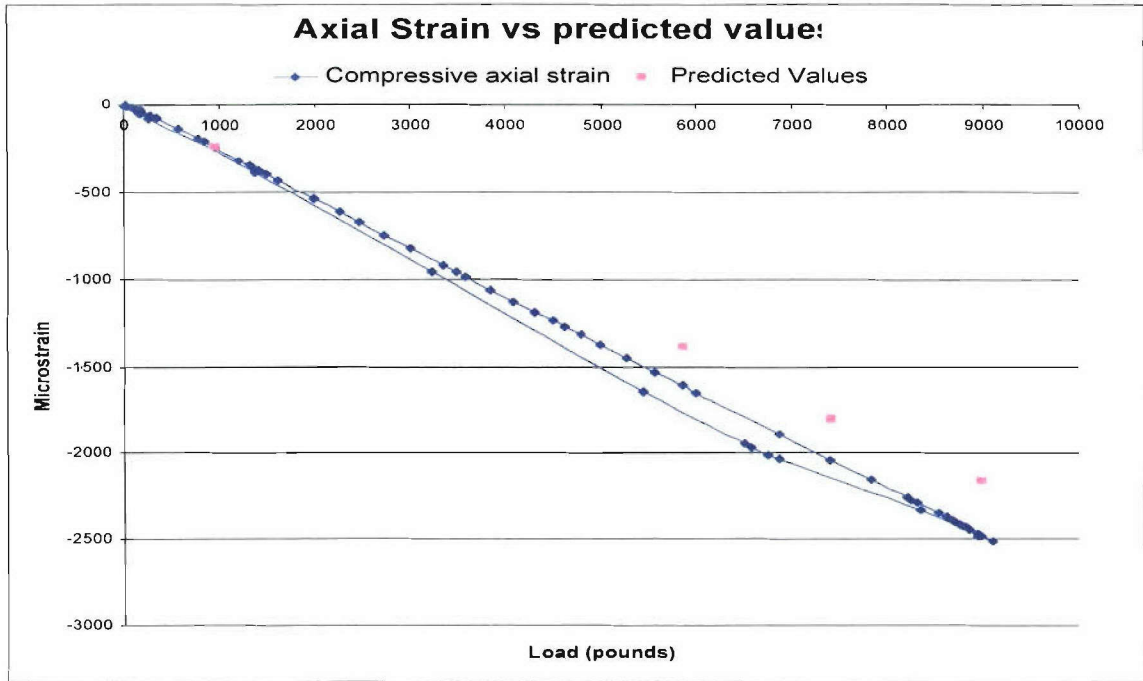

FIGURE S-5. Compressive Axial Strain at Forward Hanger.

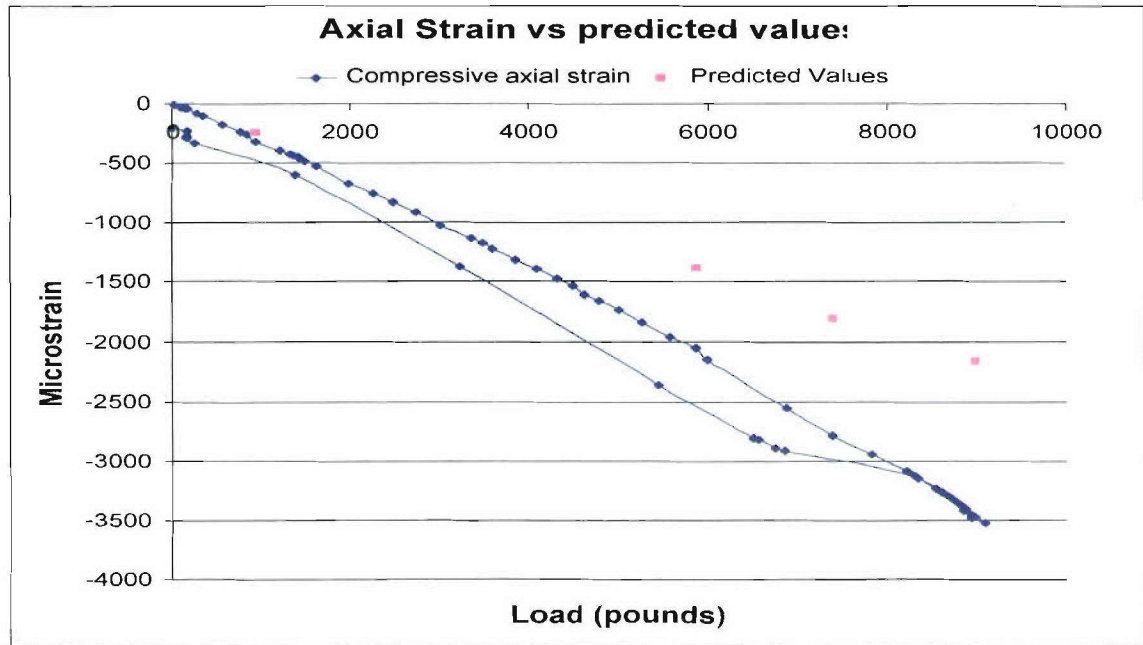

FIGURE S-6. Compressive Axial Strain at Worst NDI Indications.

ULTIMATE TEST

The next stage in the test was to increase the load on the tube until failure. Refer back to Figure S-4 for the load application history.

As the load was increased, there were no audible popping noises until catastrophic failure at 18,023 pounds. The strain gages for the rosettes at the forward hanger and the aft edge of the warhead (both on the compressive side of the tube) are presented in Figures S-7 and S-8. The data show nice linear behavior well past the 11,700-pound ultimate load. The strain gage in the area of all the NDI indications shows that damage is occurring after ultimate load that results in a strain redistribution and a softening of that area. This may help to explain why the location in the final failure is NOT in this area but a little farther aft on the tube. Figures S-9 and S-10 show the failed area on the tube. Figures S-9 and S-10 show the failed area on the tube.

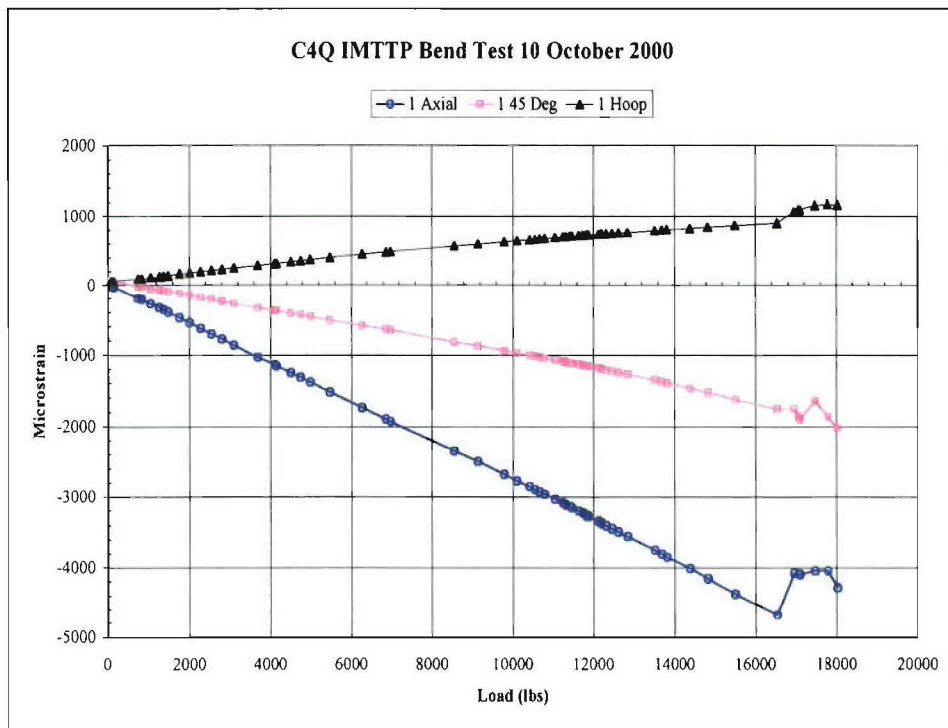

FIGURE S-7. Strain Data at Forward Hanger (Ultimate Loading).

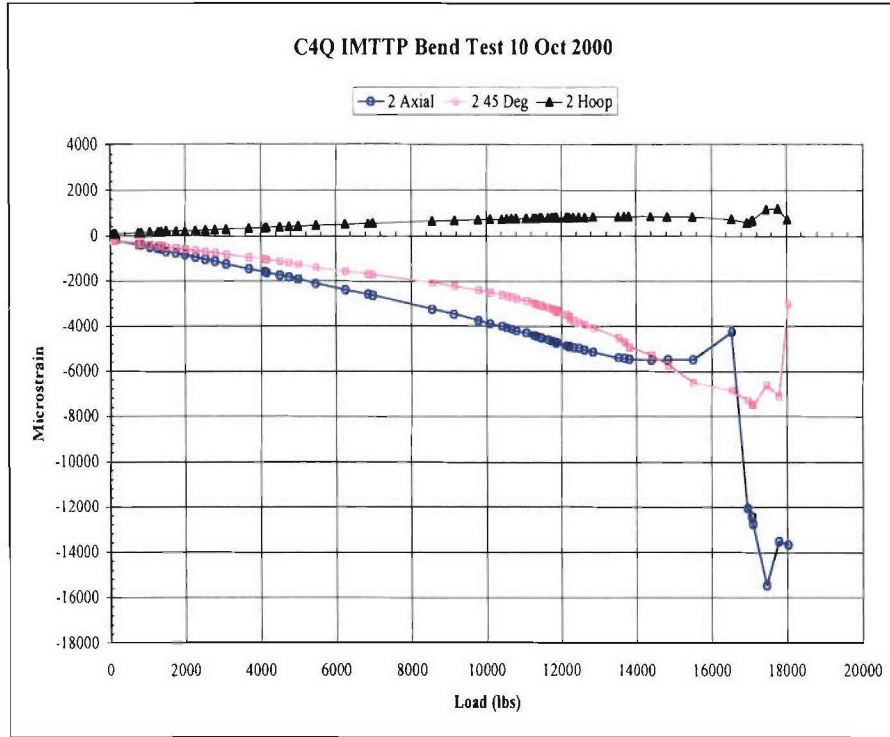

FIGURE S-8. Strain Data at Aft Edge of Warhead Section (Ultimate Loading).

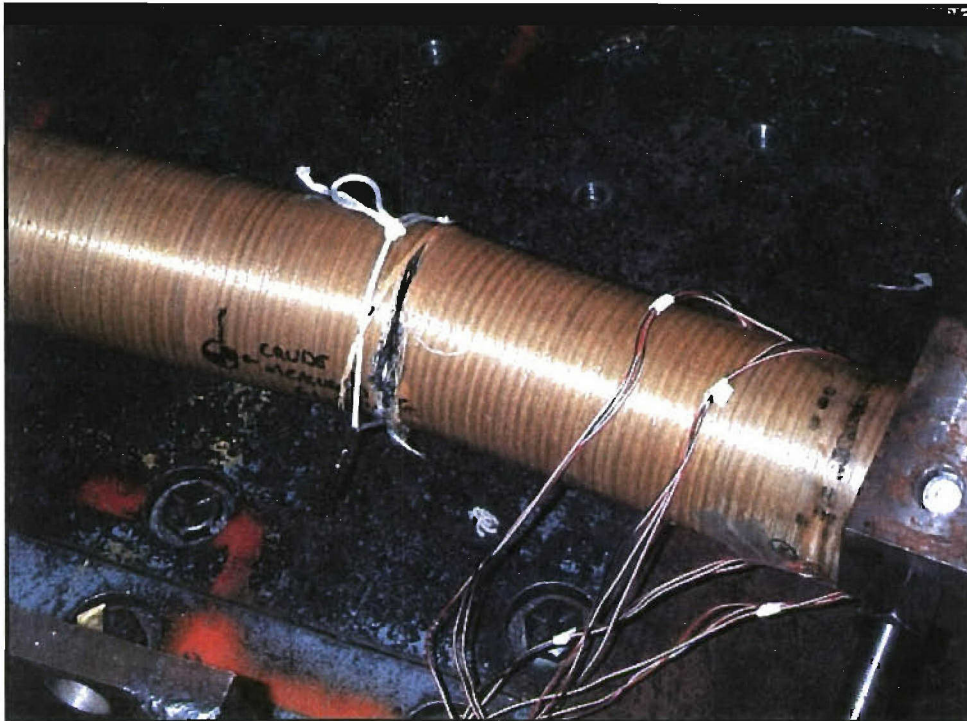

FIGURE S-9. Ultimate Failure Location (View 1).

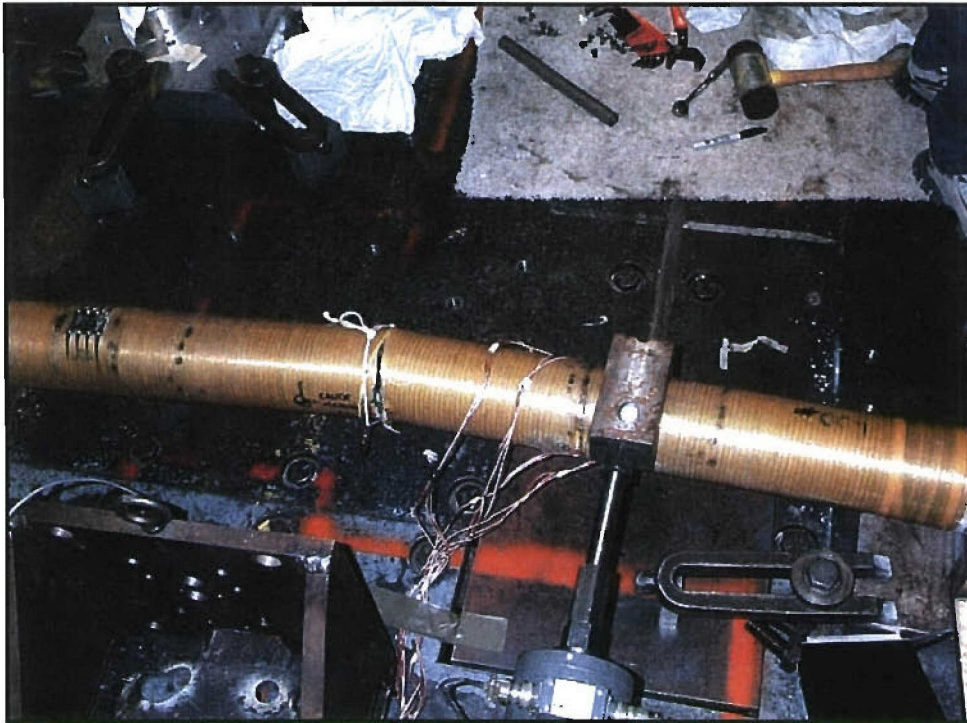

FIGURE S-10. Ultimate Failure Location (View 2).

SUMMARY

The C⁴Q composite blue tube passed the ultimate bending test after a full lifetime of vibration testing. The test was performed with the load increased to cover a factor of safety of 1.5 plus the additional material margins allowed for hot/wet and impact damage. Based on the increased required load of 11,700 pounds and the failure of the tube at 18,023 pounds, the margin for the post vibration test C⁴Q hardware is shown in Equation S-5.

$$M.S. = \frac{18023}{11700} - 1 = +0.54 \quad (S-5)$$

There were multiple 1/4-inch NDI indications in the most highly loaded areas of the test article before the load test. These results help to provide confidence that the flaw sizes detected are small enough not to adversely affect a healthy margin for the worst-case loading conditions.

Appendix T
COMPOSITE CASE CAPTIVE CARRY QUALIFICATION (C⁴Q) BLUE
TUBE BENDING AFTER IMPACT DAMAGE TEST REPORT

CONTENTS

1.0	Scope.....	T-5
2.0	Discussion.....	T-5
3.0	Bending Tests	T-5
3.1	Blue Tube Serial Number 007.....	T-7
3.2	Blue Tube Serial Number 008.....	T-14
4.0	Test Hardware.....	T-22
5.0	Disposition of Hardware.....	T-23

Figures:

T-1.	Test Setup.....	T-5
T-2.	Drawing of Bending Test Article.....	T-6
T-3.	Blue Tube Serial Number 007 After Failure.....	T-7
T-4.	Failed Area of Blue Tube Serial Number 007.....	T-8
T-5.	Yield Condition Load History (Blue Tube Serial Number 007).....	T-8
T-6.	Yield Condition Load vs. Displacement (Blue Tube Serial Number 007).....	T-9
T-7.	Yield Condition Load vs. Microstrain, Gage 1 (Blue Tube Serial Number 007).....	T-9
T-8.	Yield Condition Load vs. Microstrain, Gage 2 (Blue Tube Serial Number 007).....	T-10
T-9.	Yield Condition Load vs. Microstrain, Gage 3 (Blue Tube Serial Number 007).....	T-10
T-10.	Yield Condition Load vs. Microstrain, Gage 4 (Blue Tube Serial Number 007).....	T-11
T-11.	Ultimate Condition Load History ((Blue Tube Serial Number 007).....	T-11
T-12.	Ultimate Condition Load vs. Displacement (Blue Tube Serial Number 007).....	T-12
T-13.	Ultimate Condition Load vs. Microstrain, Gage 1 (Blue Tube Serial Number 007).....	T-12
T-14.	Ultimate Condition Load vs. Microstrain, Gage 2 (Blue Tube Serial Number 007).....	T-13
T-15.	Ultimate Condition Load vs. Microstrain, Gage 3 (Blue Tube Serial Number 007).....	T-13
T-16.	Ultimate Condition Load vs. Microstrain, Gage 4 (Blue Tube Serial Number 007).....	T-14
T-17.	Instrumentation for Blue Tube Serial Number 008.....	T-15
T-18.	Blue Tube Serial Number 008 After Failure.....	T-15
T-19.	Failed Area of Blue Tube Serial Number 008.....	T-16
T-20.	Yield Condition Load History (Blue Tube Serial Number 008).....	T-16
T-21.	Yield Condition Load vs. Displacement (Blue Tube Serial Number 008).....	T-17
T-22.	Yield Condition Load vs. Microstrain, Gage 1 (Blue Tube Serial Number 008).....	T-17
T-23.	Yield Condition Load vs. Microstrain, Gage 2 (Blue Tube Serial Number 008).....	T-18
T-24.	Yield Condition Load vs. Microstrain, Gage 3 (Blue Tube Serial Number 008).....	T-18
T-25.	Yield Condition Load vs. Microstrain, Gage 4 (Blue Tube Serial Number 008).....	T-19
T-26.	Ultimate Condition Load History (Blue Tube Serial Number 008).....	T-19
T-27.	Ultimate Condition Load vs. Displacement (Blue Tube Serial Number 008).....	T-20
T-28.	Ultimate Condition Load vs. Microstrain, Gage 1 (Blue Tube Serial Number 008).....	T-20
T-29.	Ultimate Condition Load vs. Microstrain, Gage 2 (Blue Tube Serial Number 008).....	T-21

3.1 BLUE TUBE SERIAL NUMBER 007

Blue tube Serial Number 007 was instrumented with a displacement potentiometer and four rosette strain gages. However, strain gages 1 and 2 were positioned 1 inch aft of the location specified in the drawing because the tube impacted at the point 19.3 inches aft of the forward end. Strain gages 3 and 4 were installed as specified in the drawing. Figures T-3 and T-4 show the failed tube. The maximum measured load and displacement were 13,563 pounds and 0.63 inch, respectively. The load history, load versus displacement, and load versus microstrain plots for this test are shown in Figures T-5 through T-10 for the yield load condition and in Figures T-11 through T-16 for the ultimate load condition.

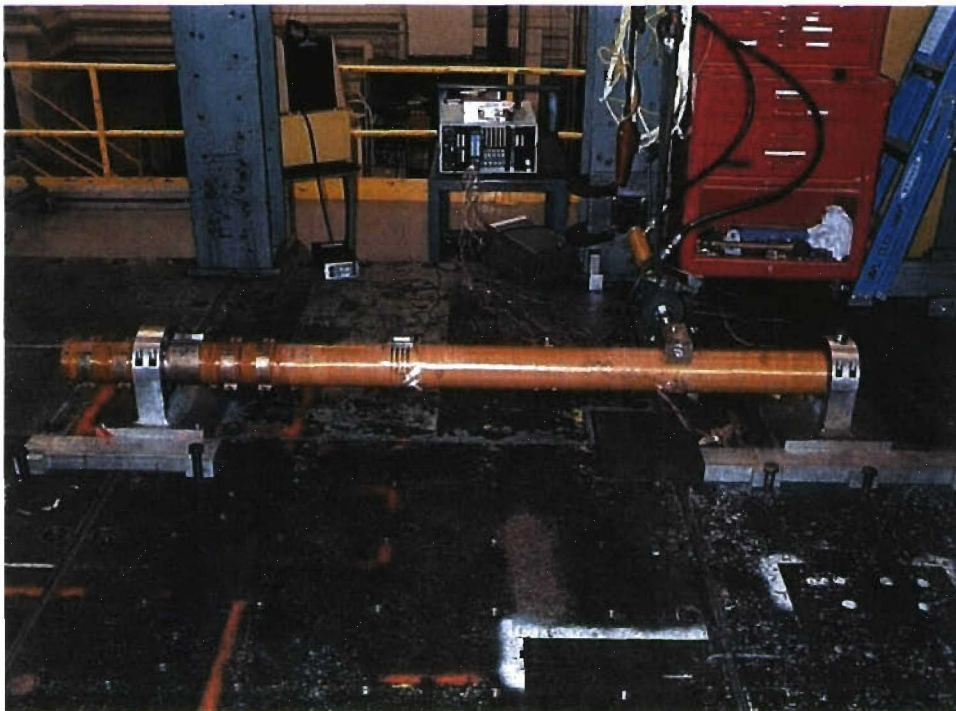

FIGURE T-3. Blue Tube Serial Number 007 After Failure.

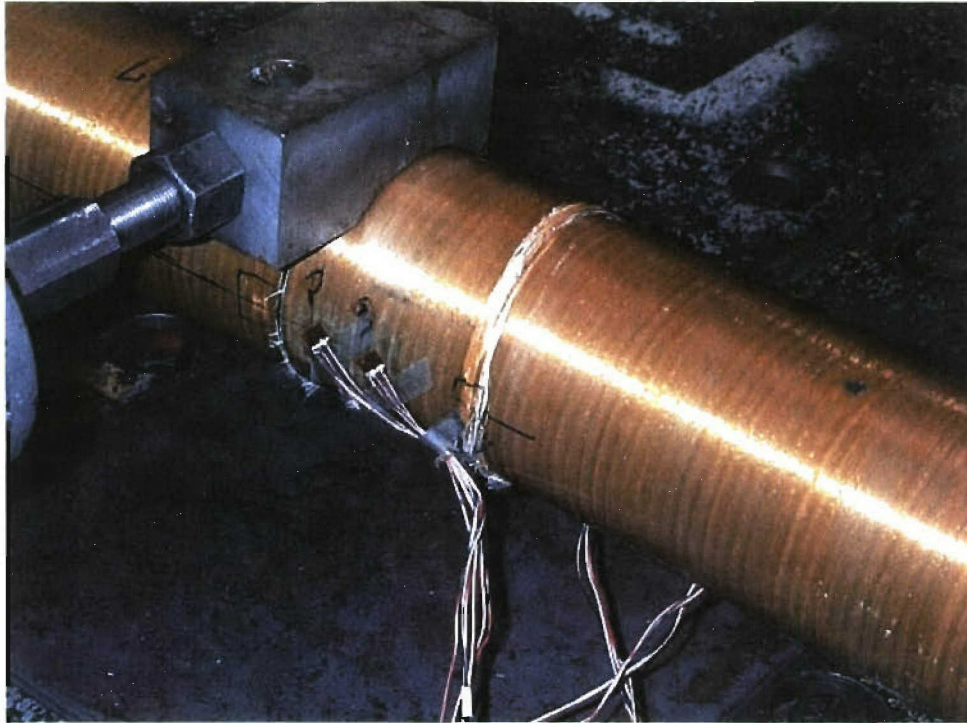

FIGURE T-4. Failed Area of Blue Tube Serial Number 007.

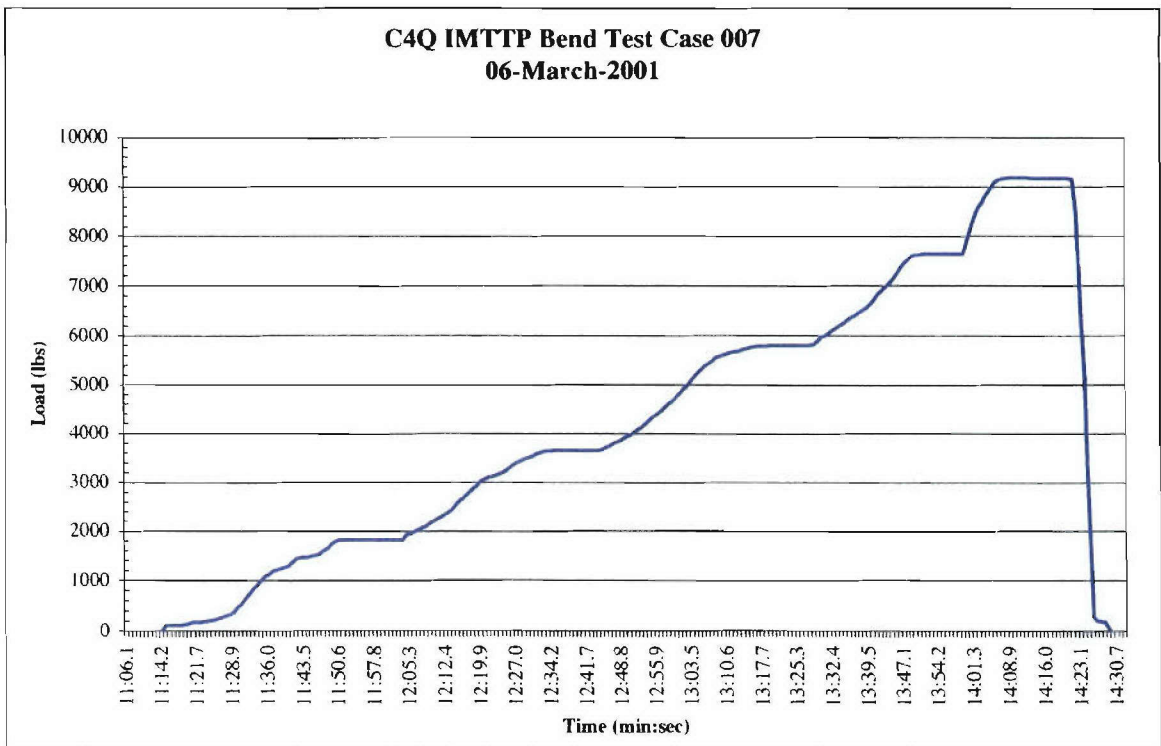

FIGURE T-5. Yield Condition Load History (Blue Tube Serial Number 007).

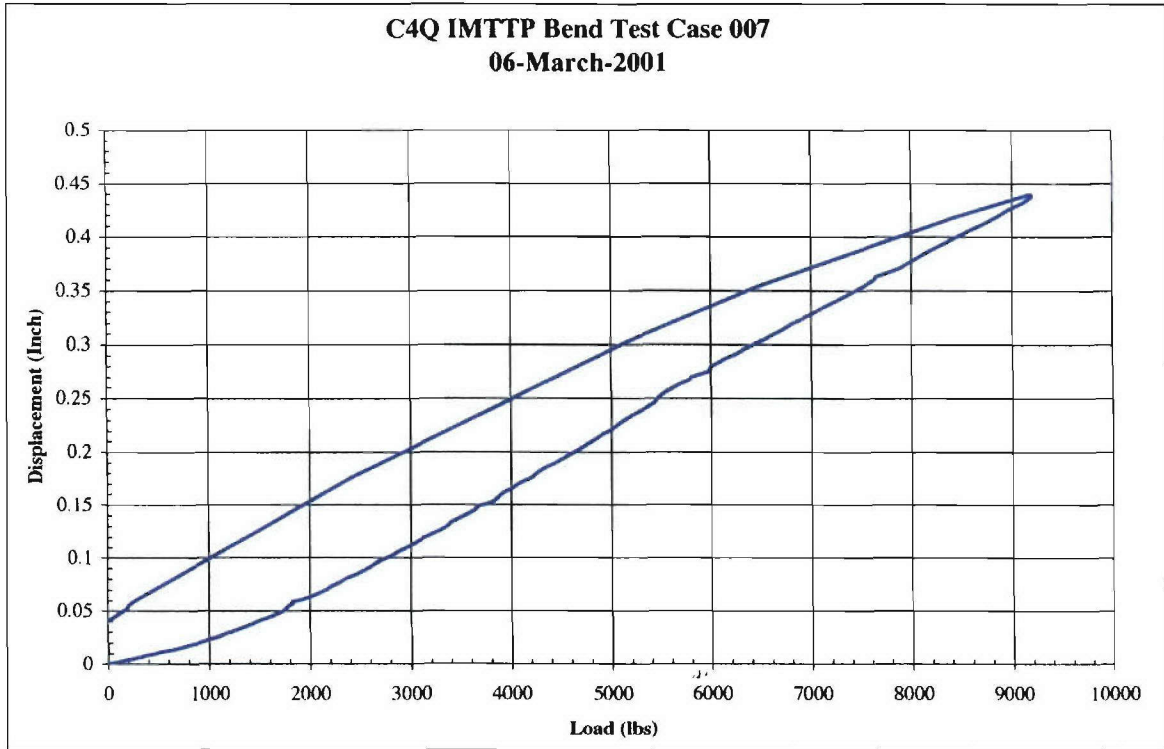

FIGURE T-6. Yield Condition Load vs. Displacement (Blue Tube Serial Number 007).

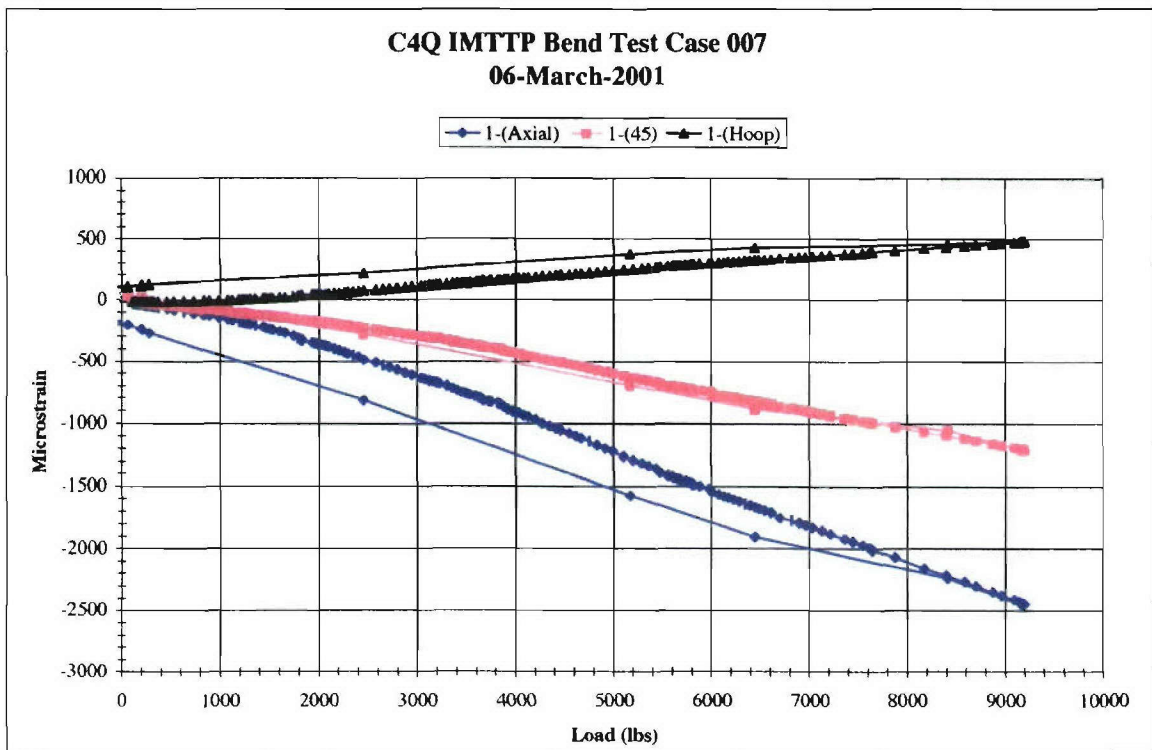

FIGURE T-7. Yield Condition Load vs. Microstrain, Gage 1 (Blue Tube Serial Number 007).

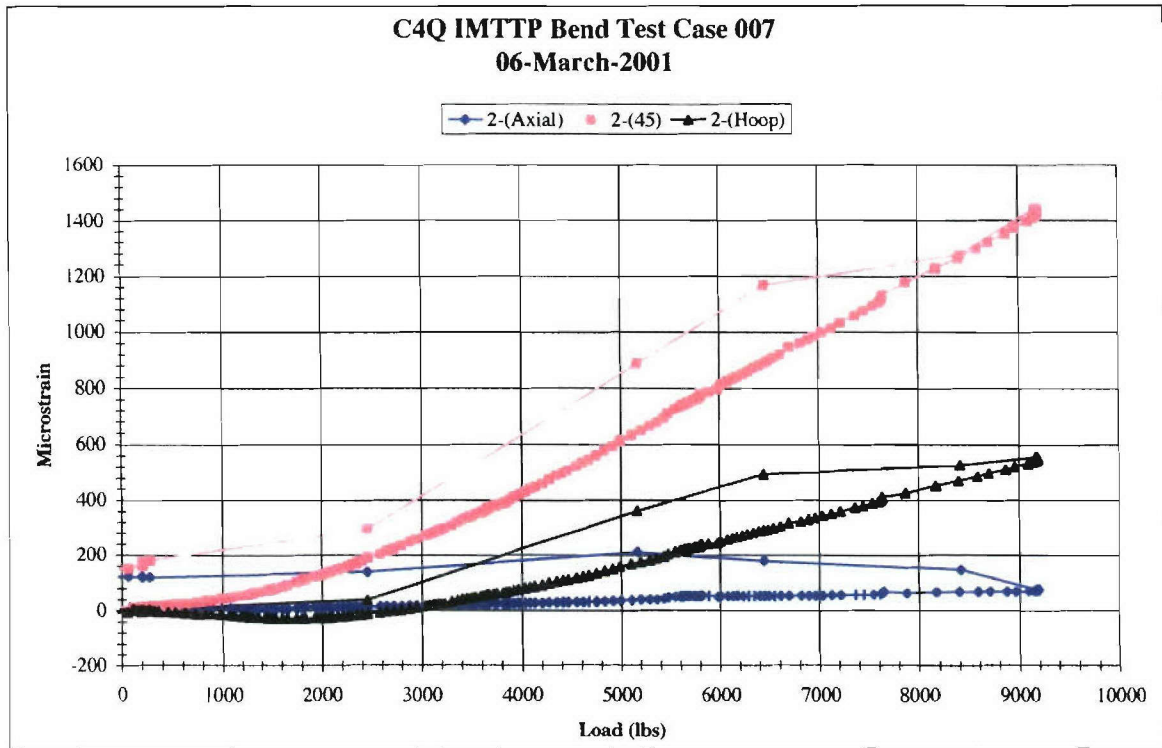

FIGURE T-8. Yield Condition Load vs. Microstrain, Gage 2 (Blue Tube Serial Number 007).

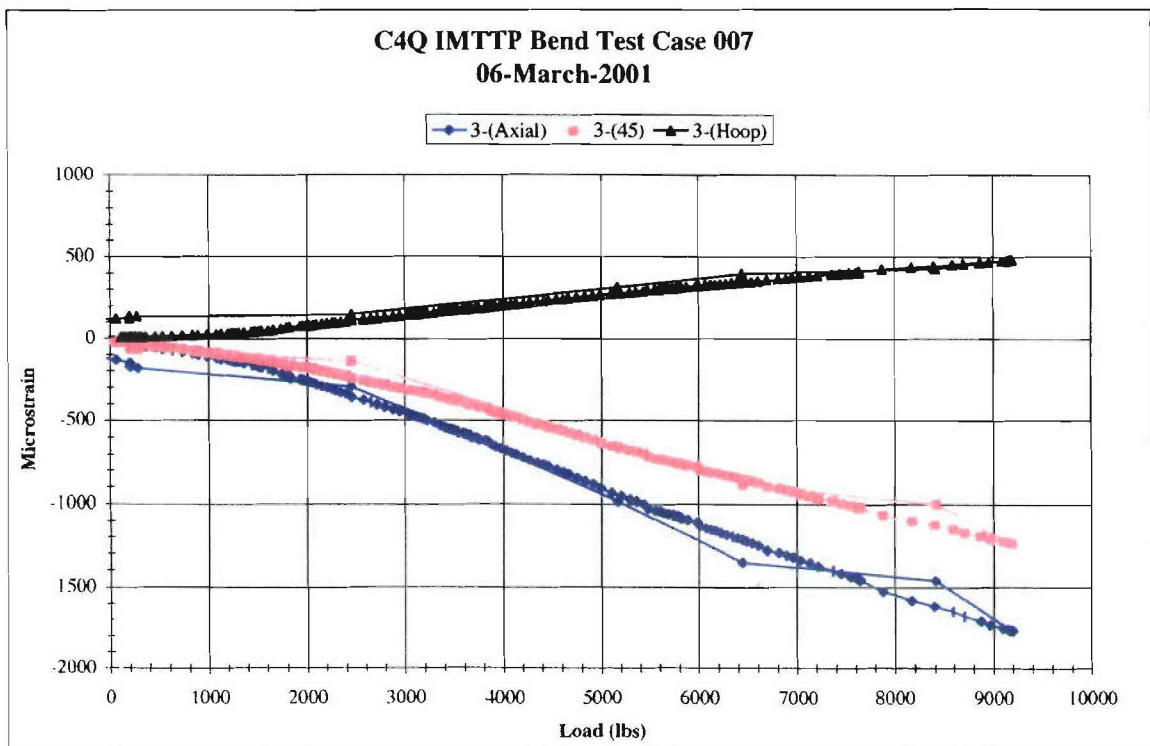

FIGURE T-9. Yield Condition Load vs. Microstrain, Gage 3 (Blue Tube Serial Number 007).

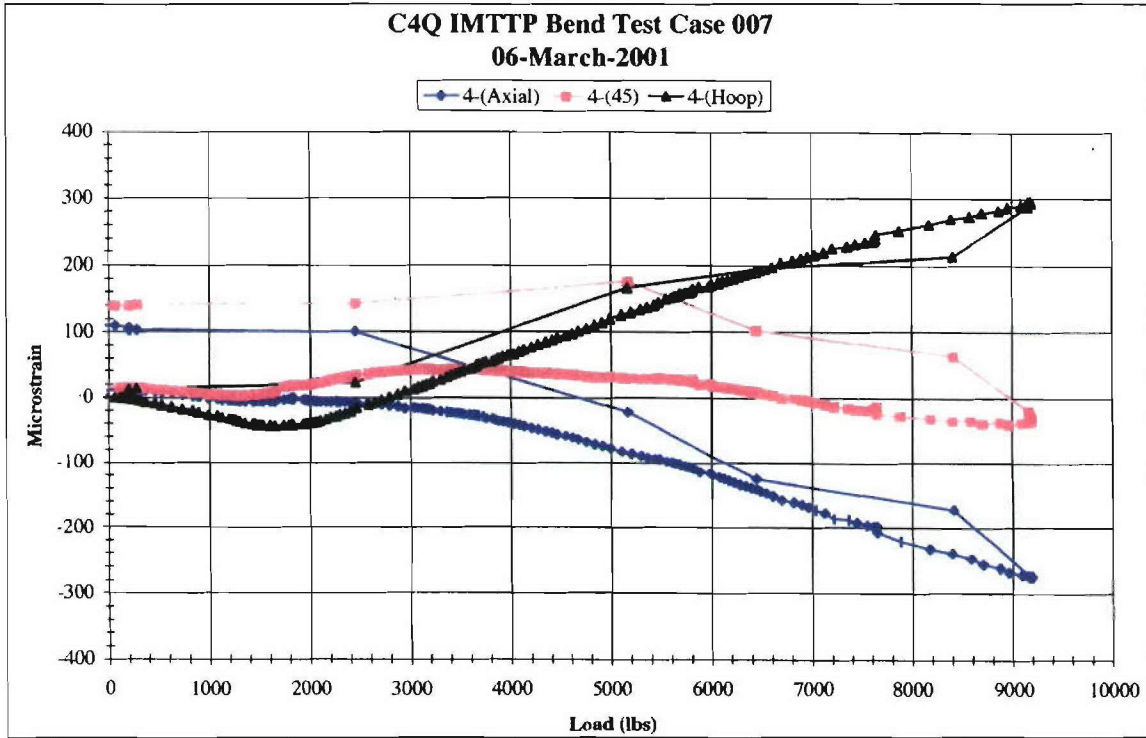

FIGURE T-10. Yield Condition Load vs. Microstrain, Gage 4 (Blue Tube Serial Number 007).

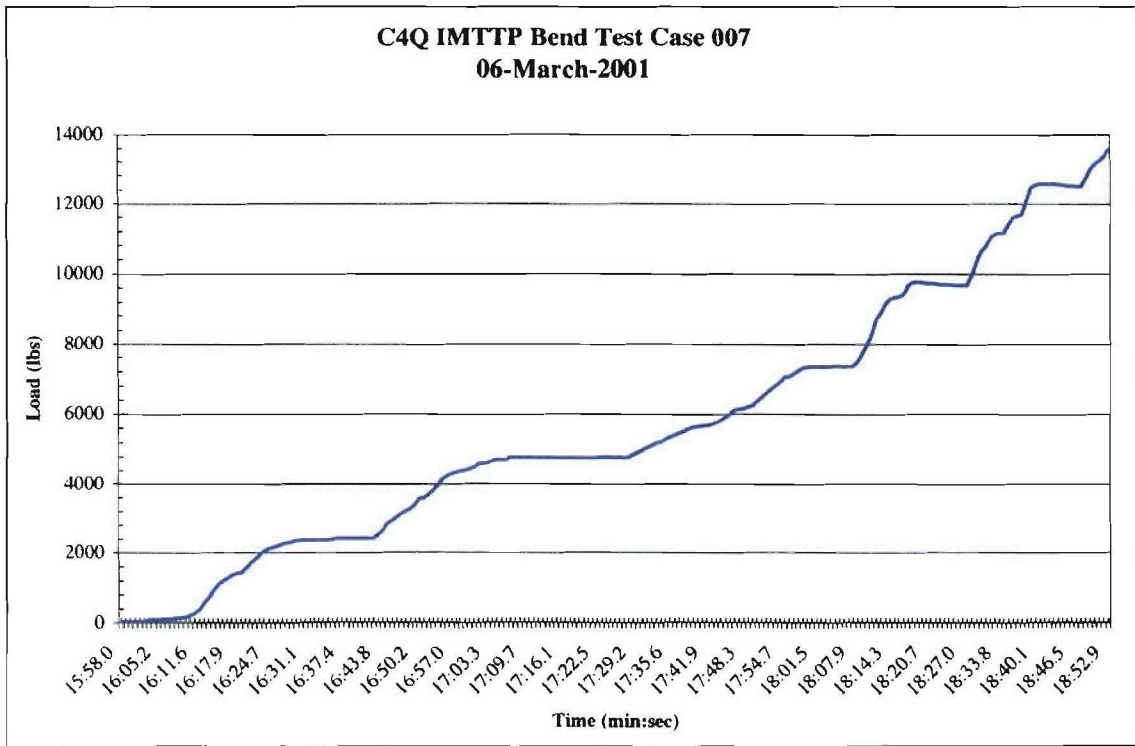

FIGURE T-11. Ultimate Condition Load History (Blue Tube Serial Number 007).

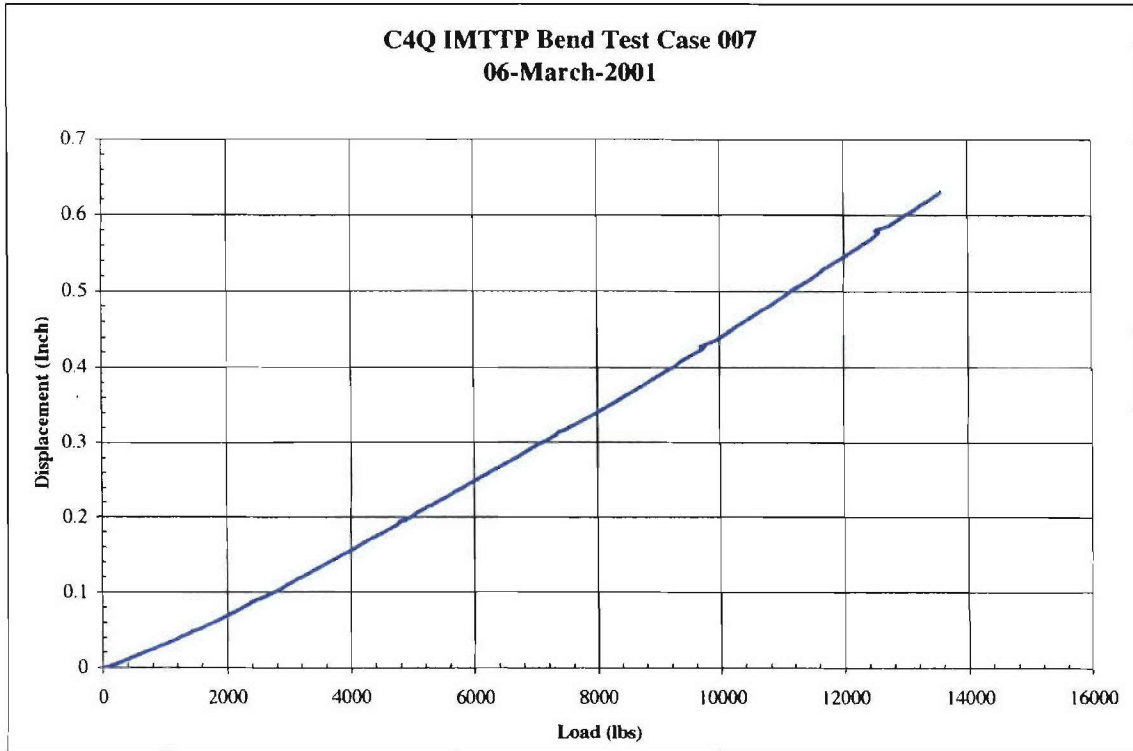

FIGURE T-12. Ultimate Condition Load vs. Displacement (Blue Tube Serial Number 007).

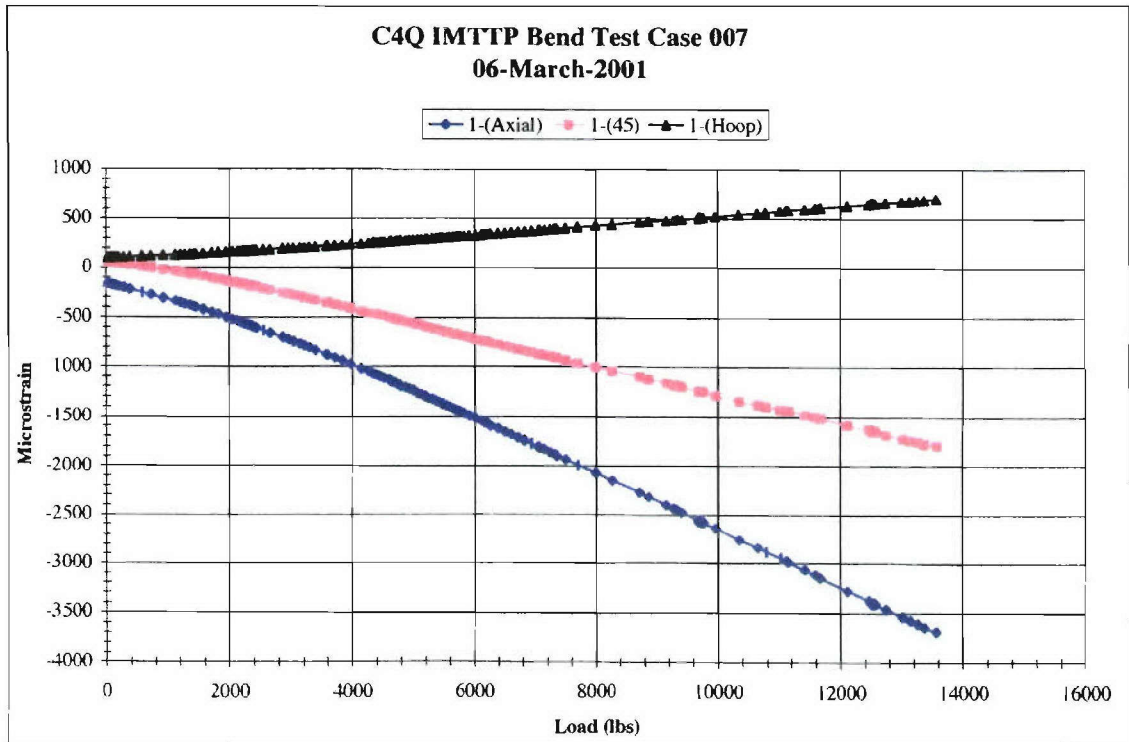

FIGURE T-13. Ultimate Condition Load vs. Microstrain, Gage 1 (Blue Tube Serial Number 007).

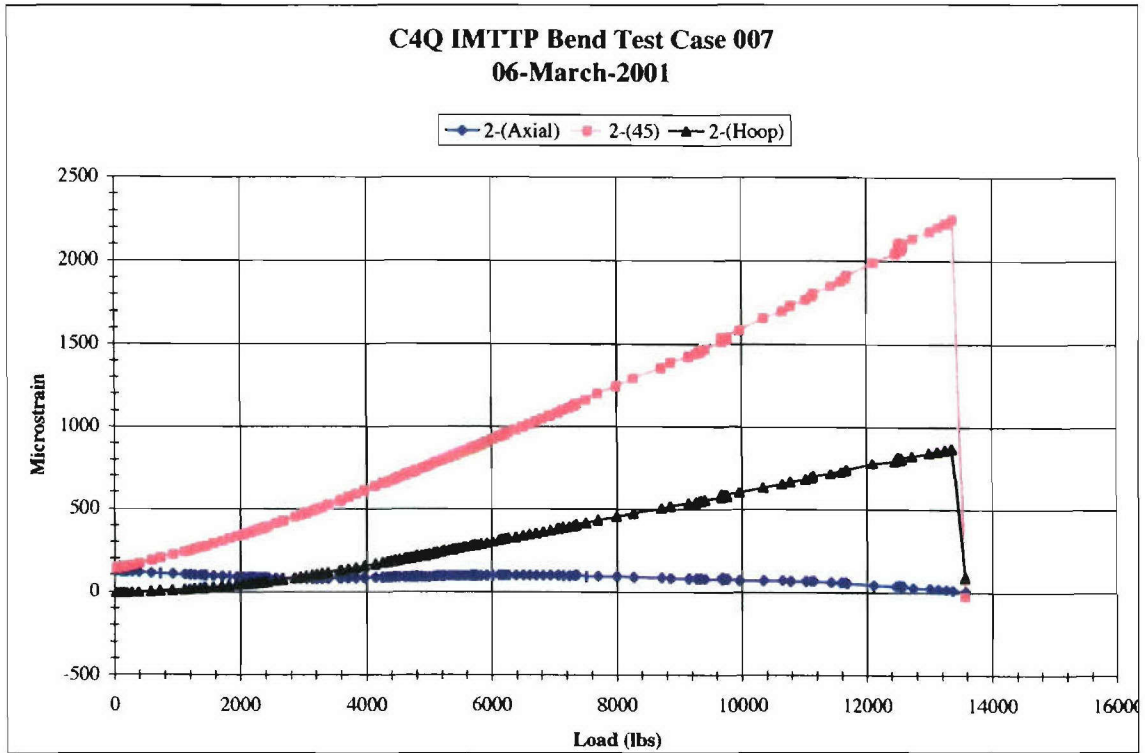

FIGURE T-14. Ultimate Condition Load vs. Microstrain, Gage 2 (Blue Tube Serial Number 007).

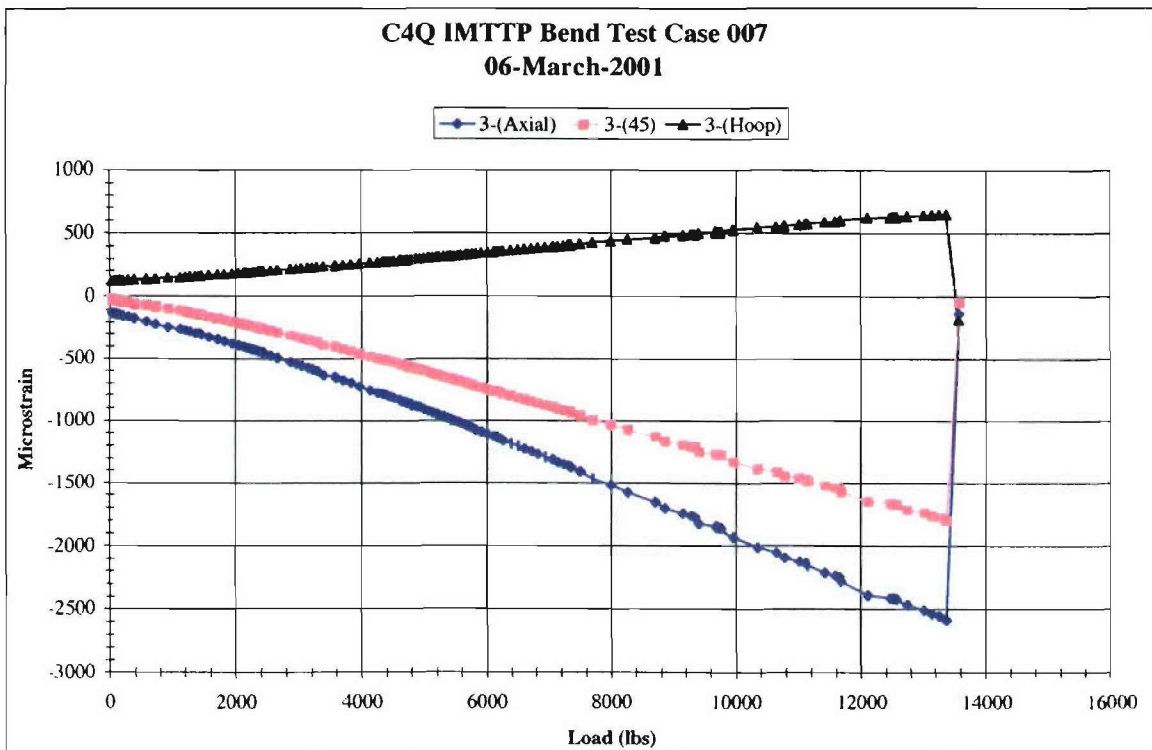

FIGURE T-15. Ultimate Condition Load vs. Microstrain, Gage 3 (Blue Tube Serial Number 007).

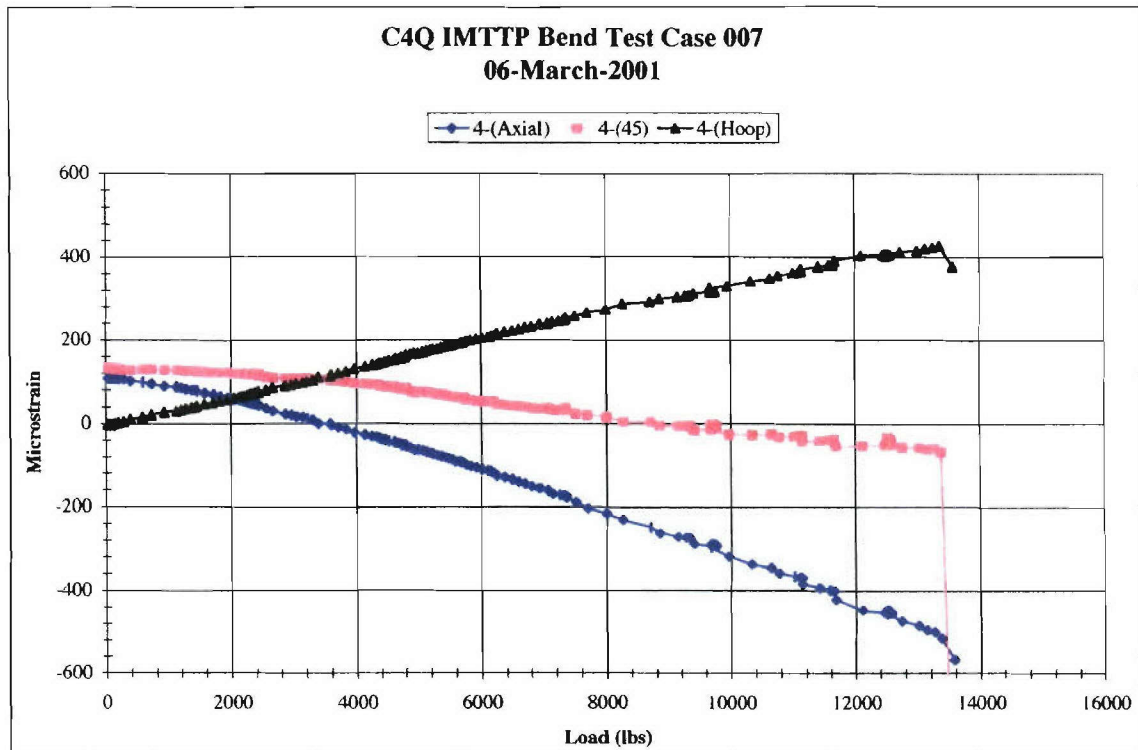

FIGURE T-16. Ultimate Condition Load vs. Microstrain, Gage 4 (Blue Tube Serial Number 007).

3.2 BLUE TUBE SERIAL NUMBER 008

Blue tube Serial Number 008 was instrumented with four rosette strain gages and displacement potentiometer as specified in the drawing and as shown in Figure T-17. Figures T-18 and T-19 show the failed tube. The maximum measured load and displacement were 9920 pounds and 0.37 inch, respectively. The load history, load versus displacement, and load versus microstrain plots for this test are shown in Figures T-20 through T-25 for the yield load condition and in Figures T-26 through T-31 for the ultimate load condition.



FIGURE T-17. Instrumentation for Blue Tube Serial Number 008.



FIGURE T-18. Blue Tube Serial Number 008 After Failure.



FIGURE T-19. Failed Area of Blue Tube Serial Number 008.

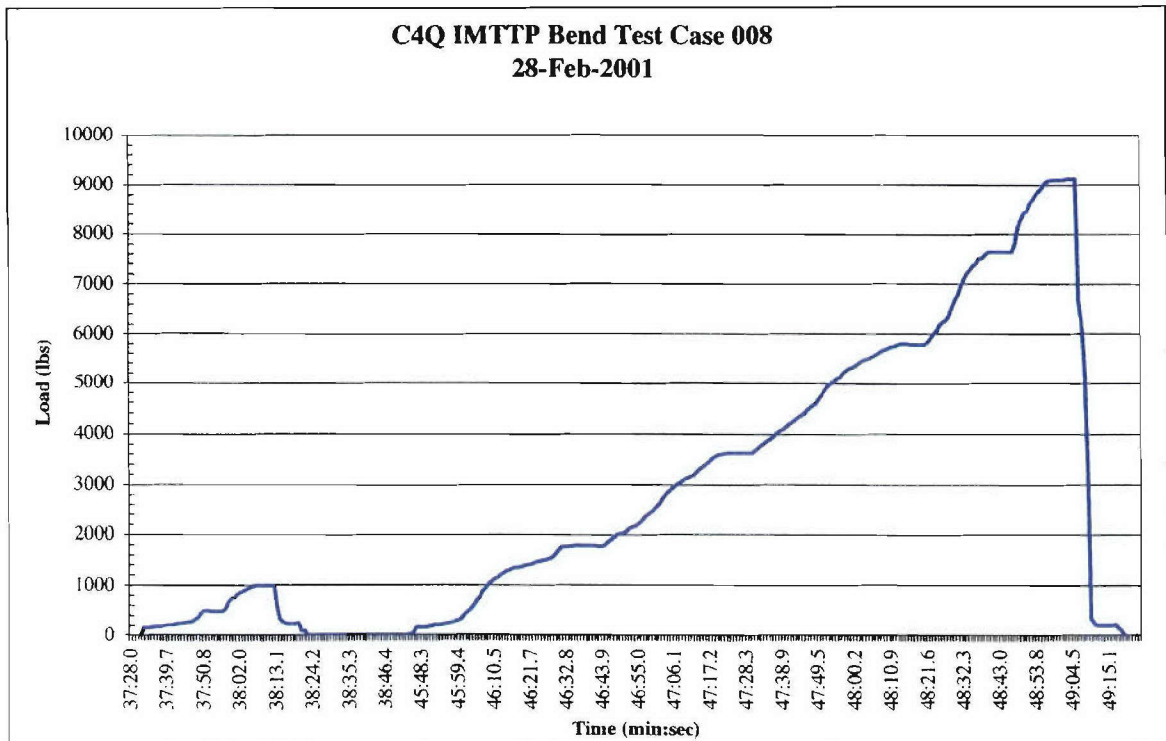

FIGURE T-20. Yield Condition Load History (Blue Tube Serial Number 008).

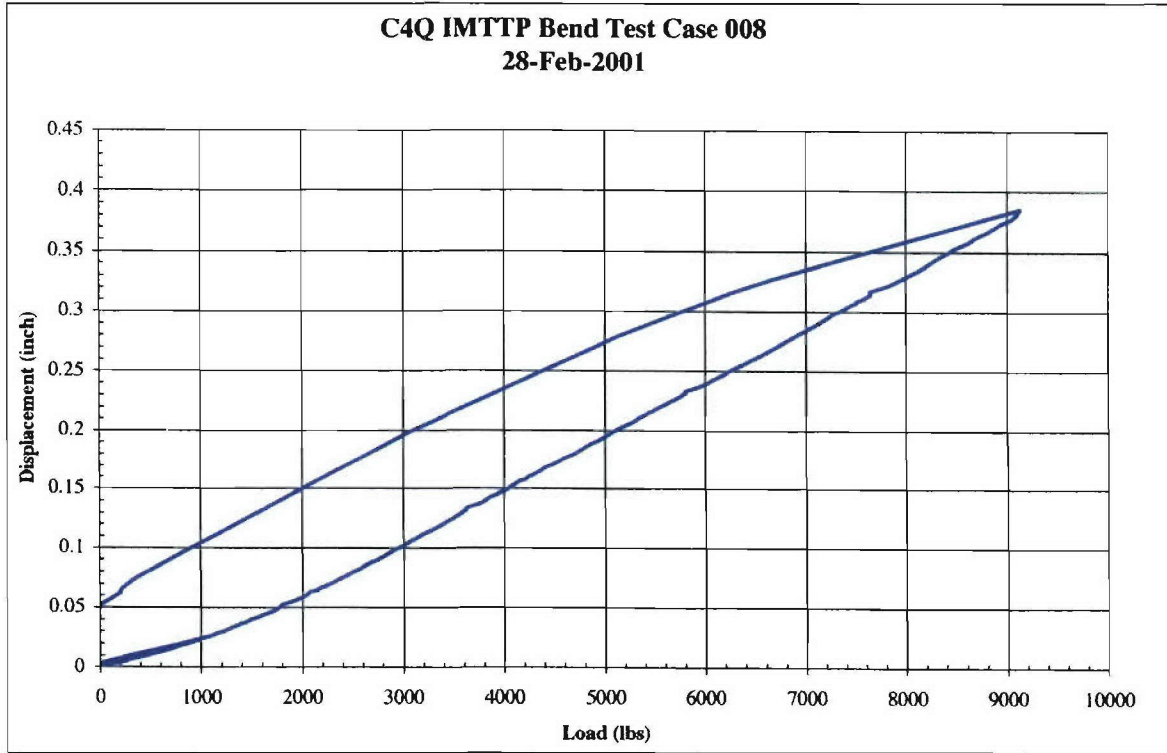

FIGURE T-21. Yield Condition Load vs. Displacement (Blue Tube Serial Number 008).

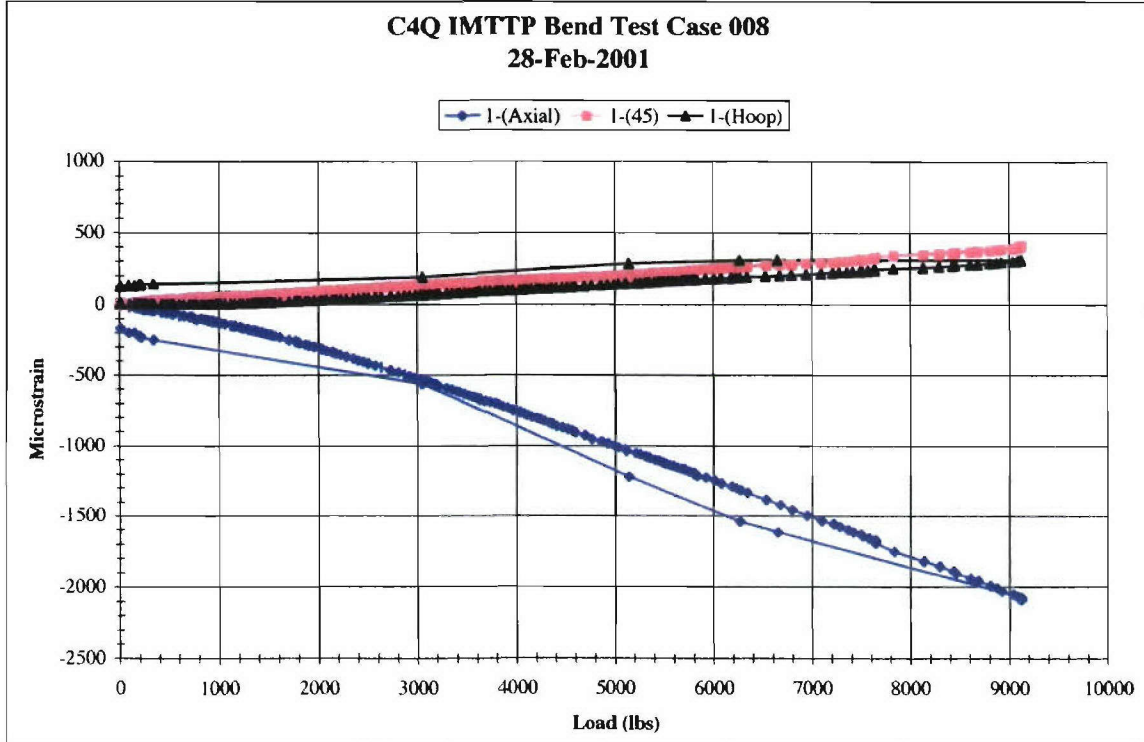

FIGURE T-22. Yield Condition Load vs. Microstrain, Gage 1 (Blue Tube Serial Number 008).

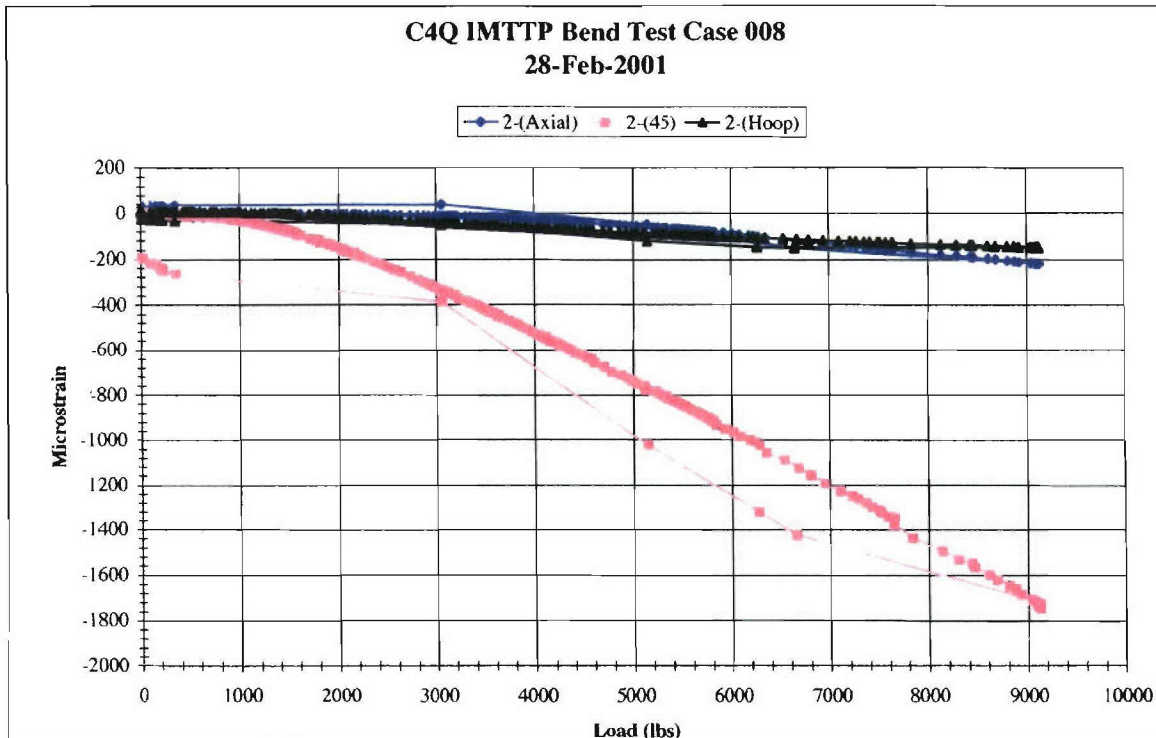

FIGURE T-23. Yield Condition Load vs. Microstrain, Gage 2 (Blue Tube Serial Number 008).

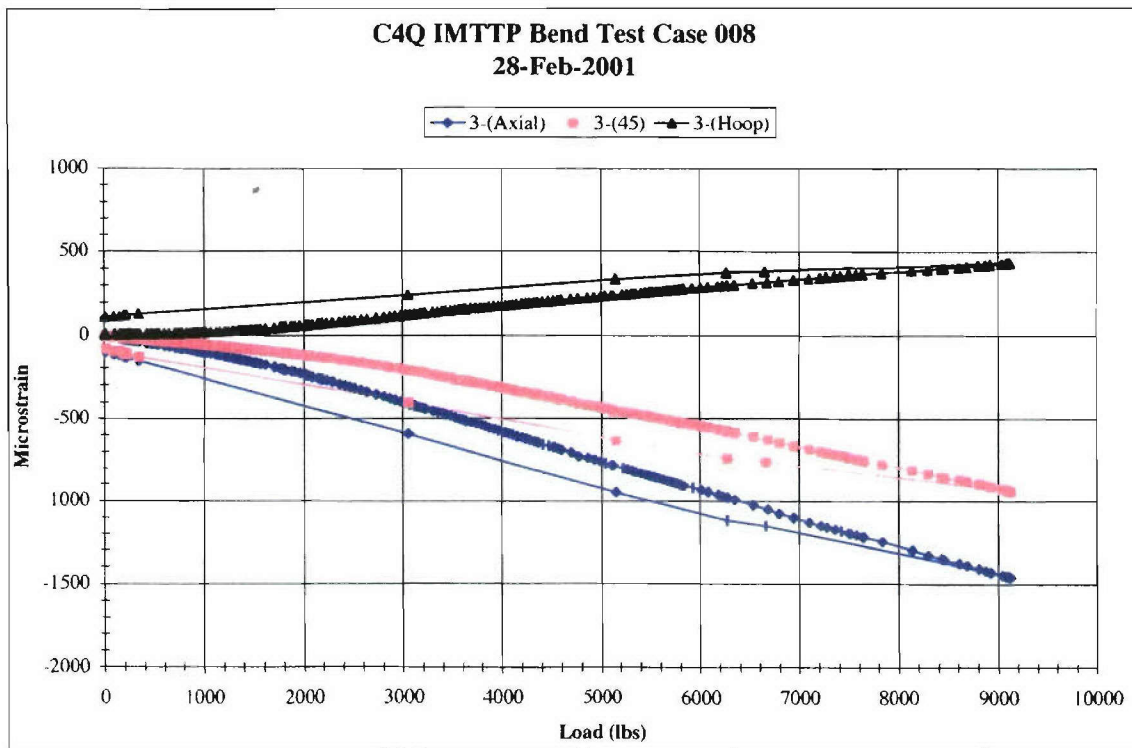

FIGURE T-24. Yield Condition Load vs. Microstrain, Gage 3 (Blue Tube Serial Number 008).

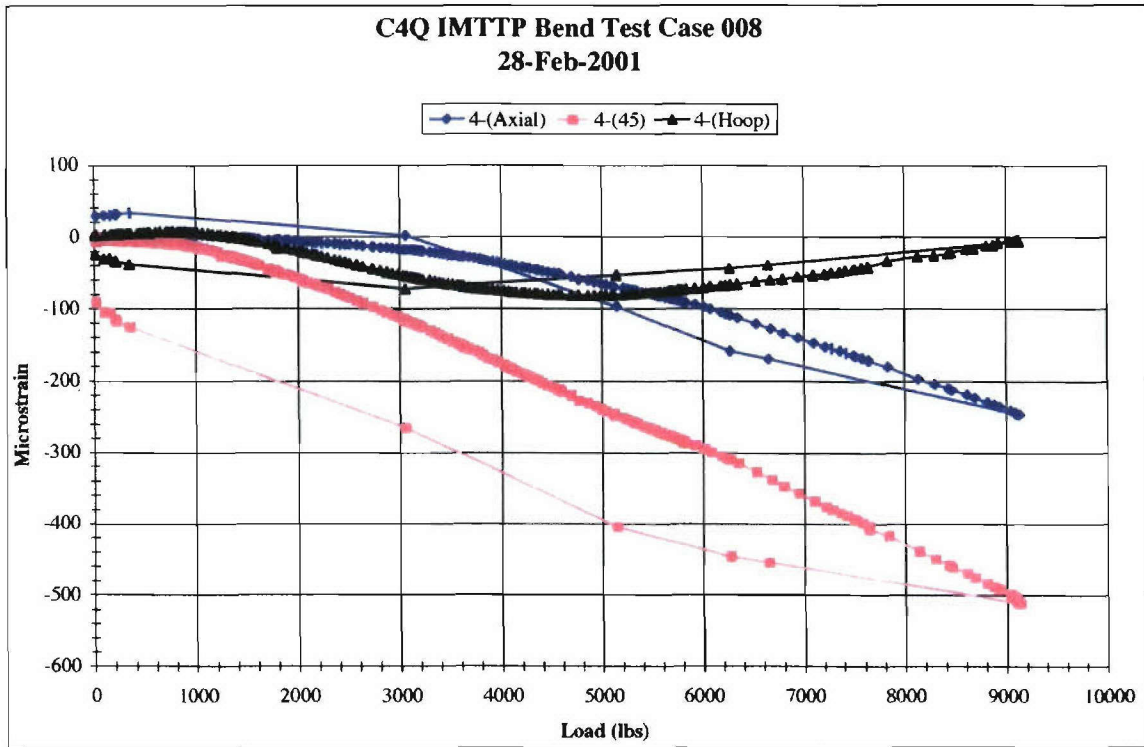

FIGURE T-25. Yield Condition Load vs. Microstrain, Gage 4 (Blue Tube Serial Number 008).

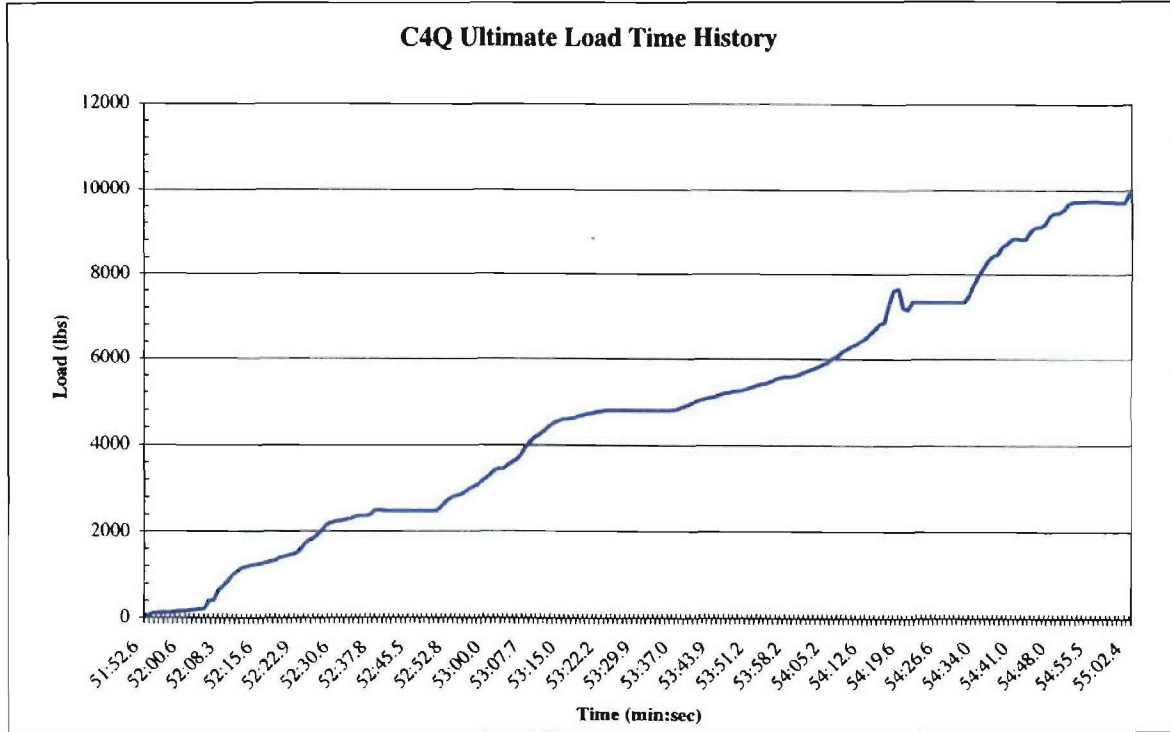

FIGURE T-26. Ultimate Condition Load History (Blue Tube Serial Number 008).

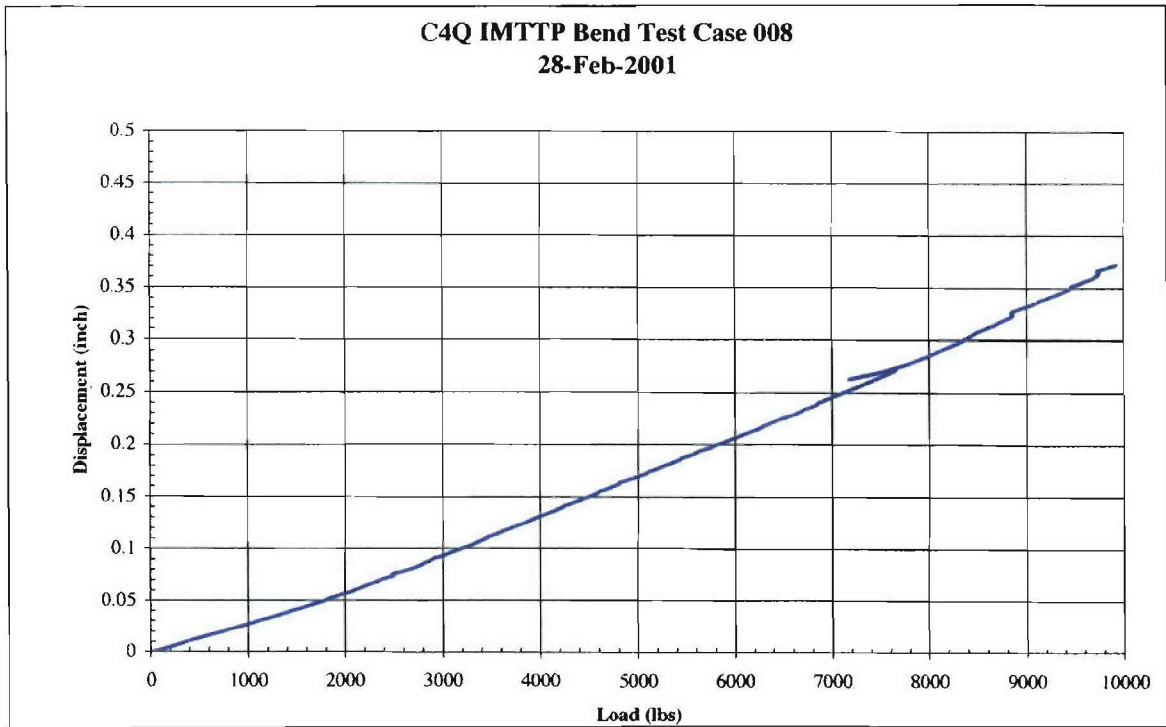

FIGURE T-27. Ultimate Condition Load vs. Displacement (Blue Tube Serial Number 008).

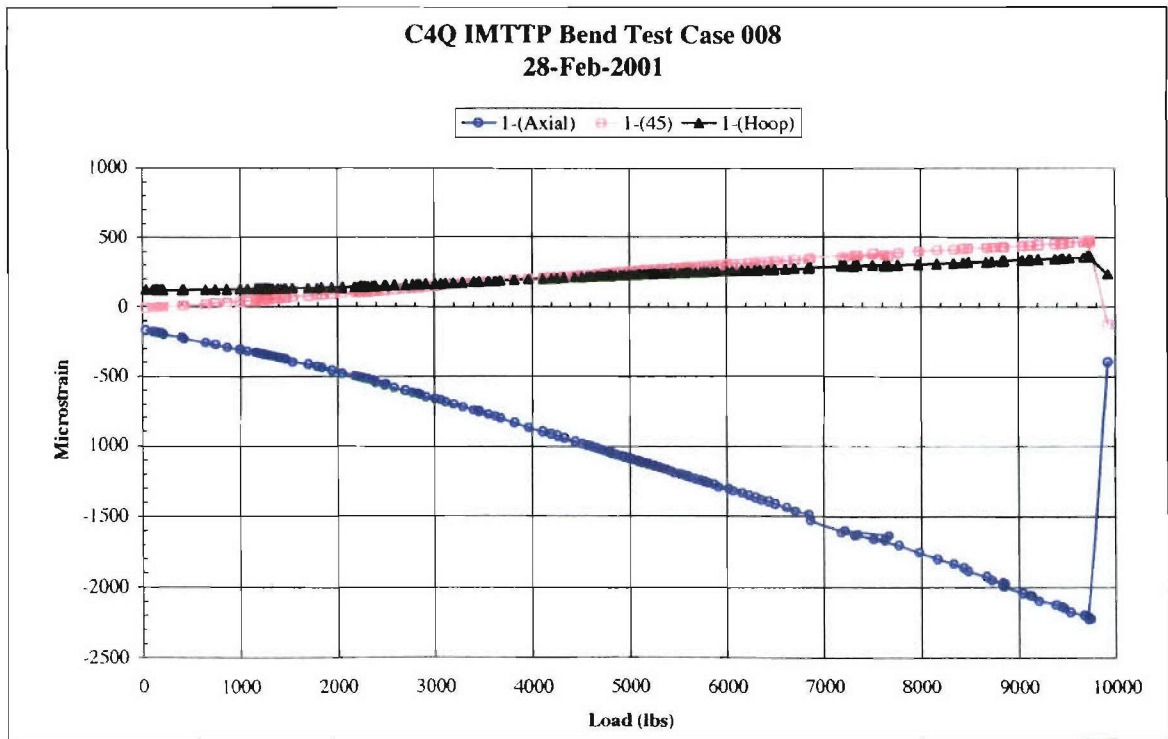

FIGURE T-28. Ultimate Condition Load vs. Microstrain, Gage 1 (Blue Tube Serial Number 008).

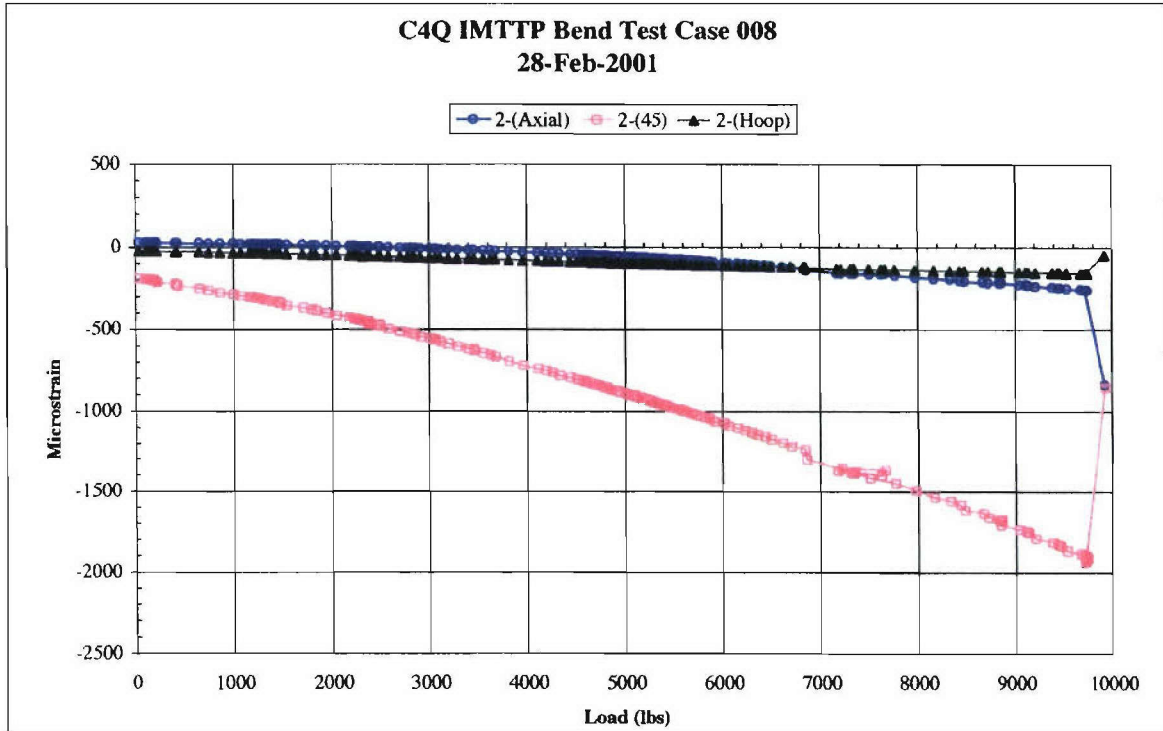

FIGURE T-29. Ultimate Condition Load vs. Microstrain, Gage 2 (Blue Tube Serial Number 008).

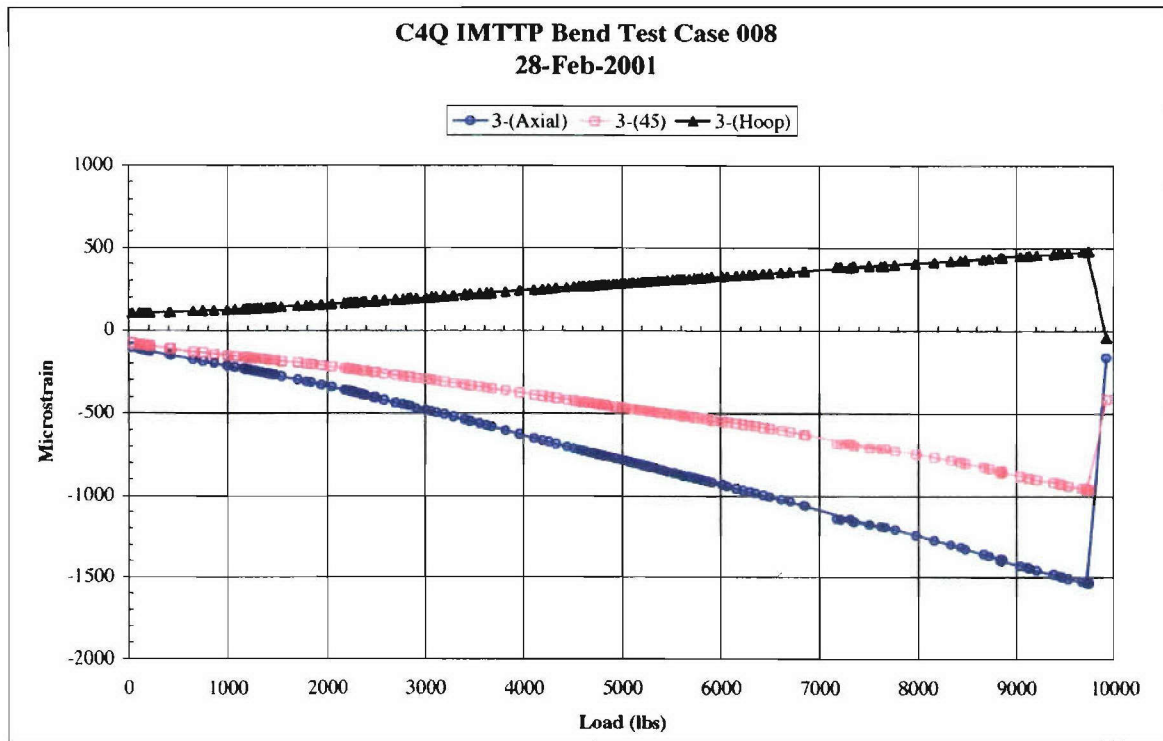

FIGURE T-30. Ultimate Condition Load vs. Microstrain, Gage 3 (Blue Tube Serial Number 008).

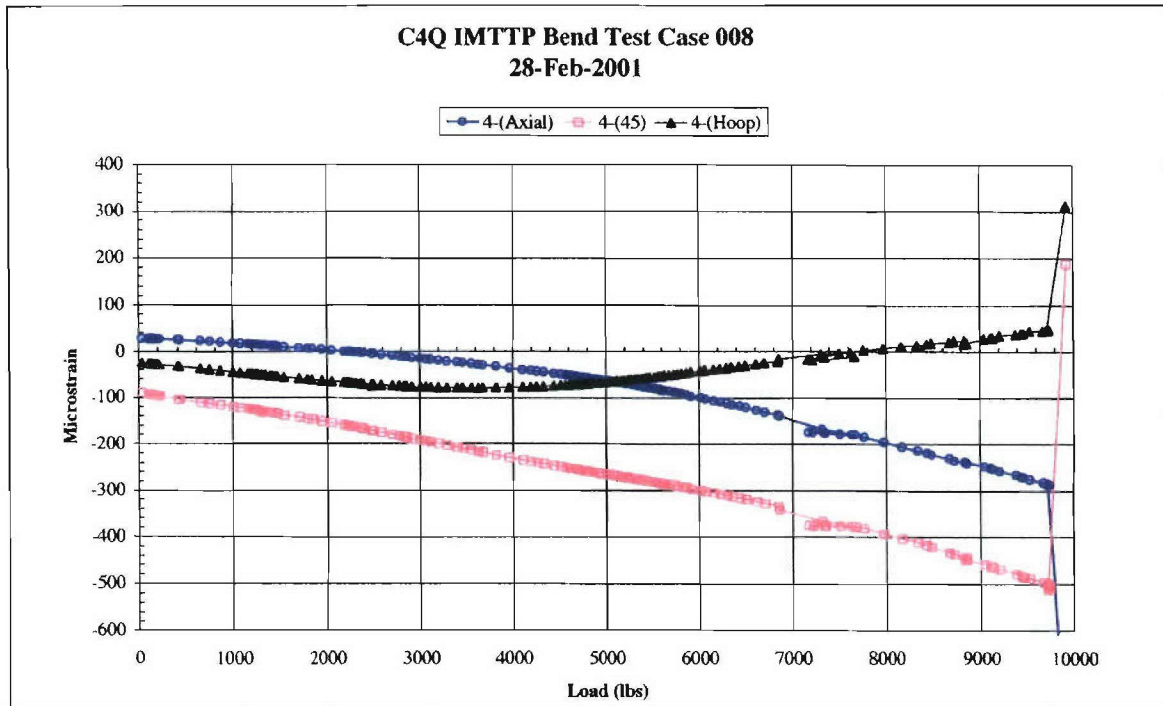

FIGURE T-31. Ultimate Condition Load vs. Microstrain, Gage 4 (Blue Tube Serial Number 008).

4.0 TEST HARDWARE

Table T-1 provides pertinent information about the test hardware.

TABLE T-1. Test Hardware Information.

Hardware	Model No./ Serial No.	Calibration Due Date
LeBow load cell	3116-106/5227	6/17/01
Schlumberger data logger	SI 3531 D/100513	05/08/01
Enerpac hydraulic pump	PEM2045	NA
Enerpac hydraulic actuator	RD 1610	NA
HP DC power supply	6228B	NA
OMEGA displacement pot.	LD600-15/M922084A035-04	User Cal

5.0 DISPOSITION OF HARDWARE

The tubes were returned to Code 476J00D for post-test inspection. The details of this inspection are not included in this report.

Appendix U
**COMPOSITE CASE CAPTIVE CARRY QUALIFICATION (C⁴Q) BLUE TUBE THERMAL
SHOCK AND TEMPERATURE, ALTITUDE, AND HUMIDITY CYCLING TEST REPORT**

CONTENTS

Test Description U-5

 Introduction..... U-5

 Test Specimen..... U-5

 Thermal Shock Loading Conditions U-5

 Temperature, Altitude, and Humidity Loading Conditions U-6

Test Results U-6

Summary..... U-7

Figures:

 U-1. Temperature Shock Cycle..... U-5

 U-2. Temperature, Altitude, and Humidity Test Cycle..... U-6

 U-3. Partial Measured Temperature, Altitude, and Humidity Test Sequence..... U-7

 U-4. Post-test Photo-micrograph..... U-8

TEST DESCRIPTION

INTRODUCTION

The thermal shock and the temperature, altitude, and humidity tests were performed on two sample sections of a Composite Case Captive Carry Qualification (C⁴Q) blue tube taken from the remains of the bending test article. These tests represent the thermal shock associated with high-temperature storage conditions followed by high-altitude flight and the temperature, altitude, and humidity cycles experienced during aircraft operations. The testing showed no visible changes to the sample, no micro-cracking of the matrix, and no apparent increase in the matrix cracks existing from manufacturing.

TEST SPECIMEN

The primary test article is a 5-inch-diameter by 6-inch-long section cut from the C⁴Q bending (room temperature, dry) test article. An additional 1-inch-long section was included through the thermal shock test only to allow a way to distinguish the effects between the two parts of the test.

THERMAL SHOCK LOADING CONDITIONS

The test item was subjected to a temperature shock test performed in accordance with MIL-STD-810, Method 503.2. Three cycles were performed using the temperature extremes of -65°F (T1) and +165°F (T2) (see Figure U-1). Transferring the test item between the two environments (high and low temperatures) occurs as rapidly as possible, but in no more than 1 minute.

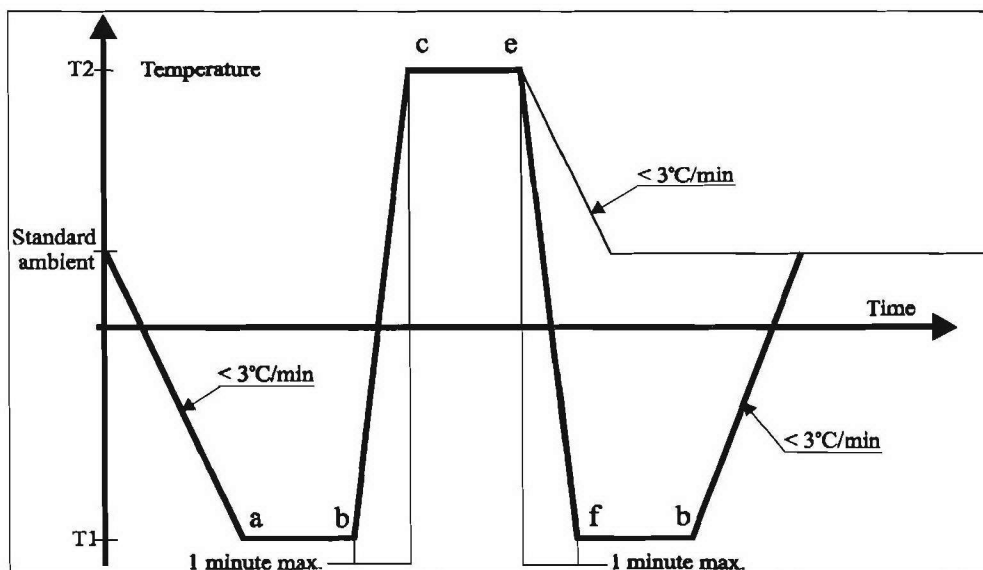

FIGURE U-1. Temperature Shock Cycle.

TEMPERATURE, ALTITUDE, AND HUMIDITY LOADING CONDITIONS

The test item was subjected to a temperature, altitude, and humidity test performed in accordance with MIL-STD-810, Method 520.1. Ten cycles were performed using the condition sequence shown in Figure U-2.

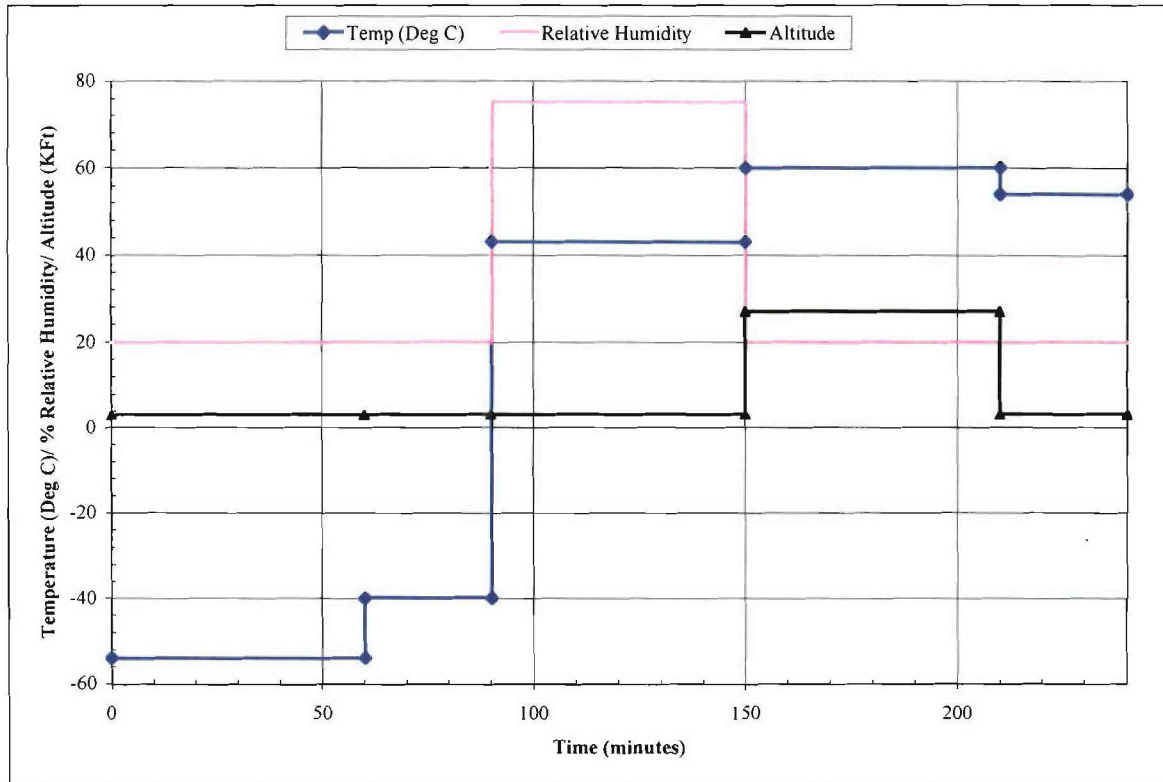

FIGURE U-2. Temperature, Altitude, and Humidity Test Cycle.

TEST RESULTS

The test was performed on 19 and 20 November 2000. All instrumentation performed as expected. The test chamber had one shutdown during the test sequence, but testing was resumed and the full remainder of the test was performed. There would not be any adverse effects from this shutdown. Figure U-3 shows a sample of the measured environment during testing. The data are repetitive, so the remainder of the data are not included.

The cycles shown in Figure U-3 were performed after the thermal shock test. That test involved changing from chamber to chamber, so no continuous data were collected. The samples were mounted, polished, and photo-micrographed by the Materials Branch. A typical image is shown in Figure U-4.

SUMMARY

MIL-STD-810, Method 503.2, was used to establish the procedures for the thermal shock test. MIL-STD-810F, Section 520.1, was used to establish the procedures and number of cycles for temperature, altitude, and humidity testing. There were no apparent adverse effects or any damage due to thermal shock or temperature, altitude, and humidity tests.

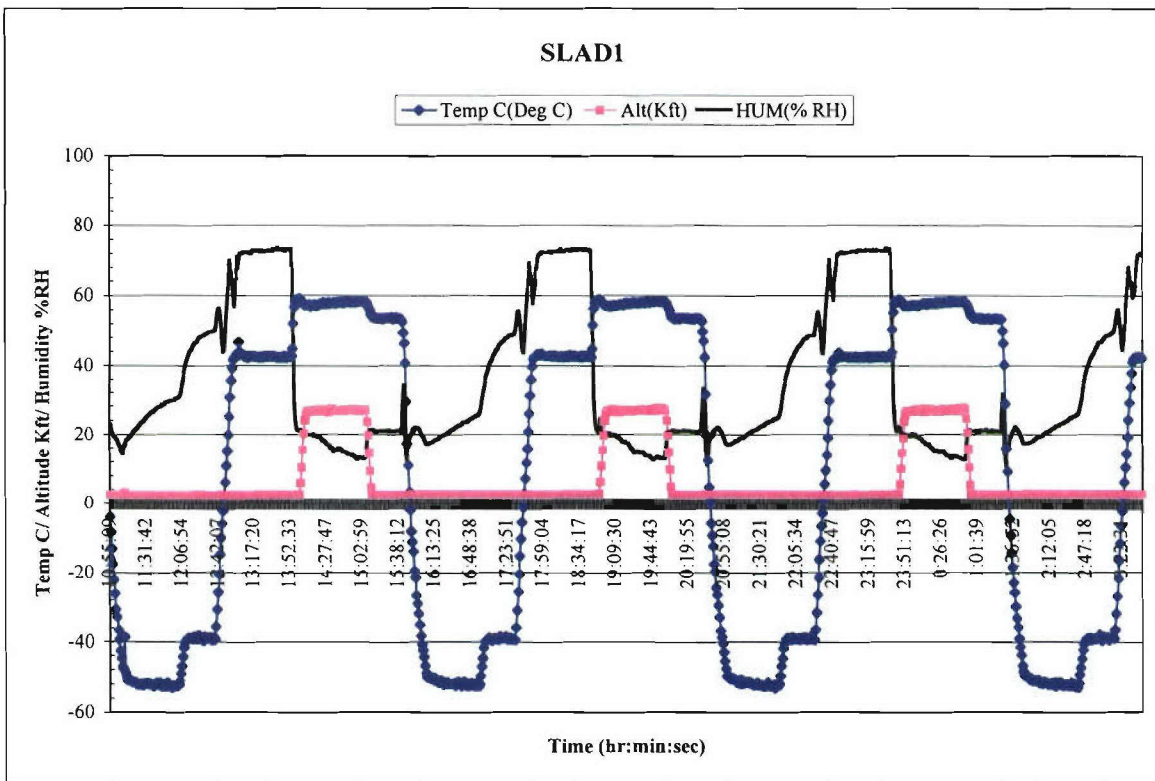

FIGURE U-3. Partial Measured Temperature, Altitude, and Humidity Test Sequence.

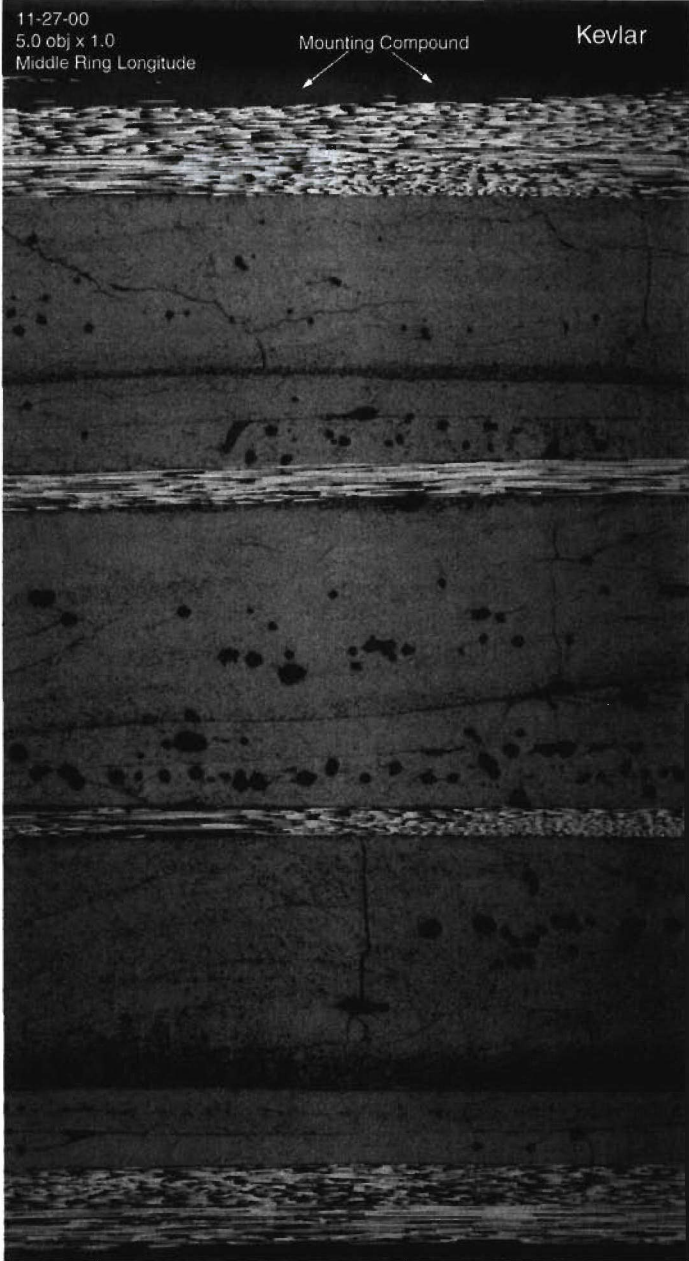

FIGURE U-4. Post-test Photo-micrograph.

Appendix V
COMPOSITE CASE CAPTIVE CARRY QUALIFICATION (C⁴Q)
BLUE TUBE PRE-FLIGHT PROOF TEST PLAN

1.0 INTRODUCTION

This test plan describes the proof test that will demonstrate that the Composite Case Captive Carry Qualification (C⁴Q) hardware meets the minimum requirements for flight testing. This test plan provides the overall instructions for conducting proof testing of the Insensitive Munitions Technology Transition Program (IMTTP) 5.0-inch composite tube.

2.0 OBJECTIVE

The primary purpose of this test is to verify that the flight test article meets the basic minimum structural integrity needed for flight testing. This test shall provide results that verify the tested C⁴Q blue tube is representative of the previously tested C⁴Q blue tubes and meets proof requirements.

3.0 TEST DESCRIPTION

Loading of the C⁴Q blue tube is a representative *g* loading case for the AIM-9M on the wing tip station of the F/A-18C/D in the aircraft Z direction. The loading represents a wind-up turn maneuver. Loading characteristics are described in the "Structural Adequacy of the Sidewinder Training Missile (CATM-9M) Onboard the F/A-18A/B/C/D Aircraft" in NAWCWPNs TM 8145 (June 1998). The loading is to provide a proof test for the worst-case scenario on board the F-18 during captive carriage (excluding the Mk 84 bomb ejection). Proof testing for the Mk 84 bomb ejection (50 *g*) condition is not feasible. If the increases in load to cover the composite knockdowns are applied, then the hangers and metal parts would be overtested. Although the C⁴Q ground test program has shown that the airframe strength is adequate for this condition, it is not recommended for flight test due to the lack of proof test.

This testing will apply an equivalent *g* loading force of 18 *g* (times 1.1 for proof load) and composite knockdown factors (times 1.25 for impact damage and times 1.25 for hot/wet strength reduction). This results in a load of 6014 lbf (31 *g*). The loading shall be applied once in only one direction (corresponding to Z direction) to verify structural adequacy of the test article.

The success criteria are as follows. Proof testing shall be considered successful if the case withstands the loading with no auditory or visual anomalous behavior in the test article that would be indicative of its inability to perform its intended use. This shall be determined by inspection and observation.

3.1 TEST ARTICLE DESCRIPTION

The test article consists of an IMTTP C⁴Q body assembly (Serial Number 008) as described in drawing number A476200D132. This is the flight test all-up round (before installation of fins, wings, and guidance and control section [GCS]).

3.2 TEST FACILITIES

The test facility is located at the Code 476300D static frame test facility.

The test equipment for this proof test consists of one hydraulic load jack, a load cell, a displacement transducer, and signal conditioning and recording equipment.

This test uses half of the fatigue test fixture. The test article is mounted to a launcher simulator designed to match the stiffness of a LAU-7 launcher. The hydraulic load jack applies the acceleration load through a wiffle tree arrangement. The wiffle tree and load jack are placed on only one side of the test article for the proof test. The fixture layout is shown in Figure V-1.

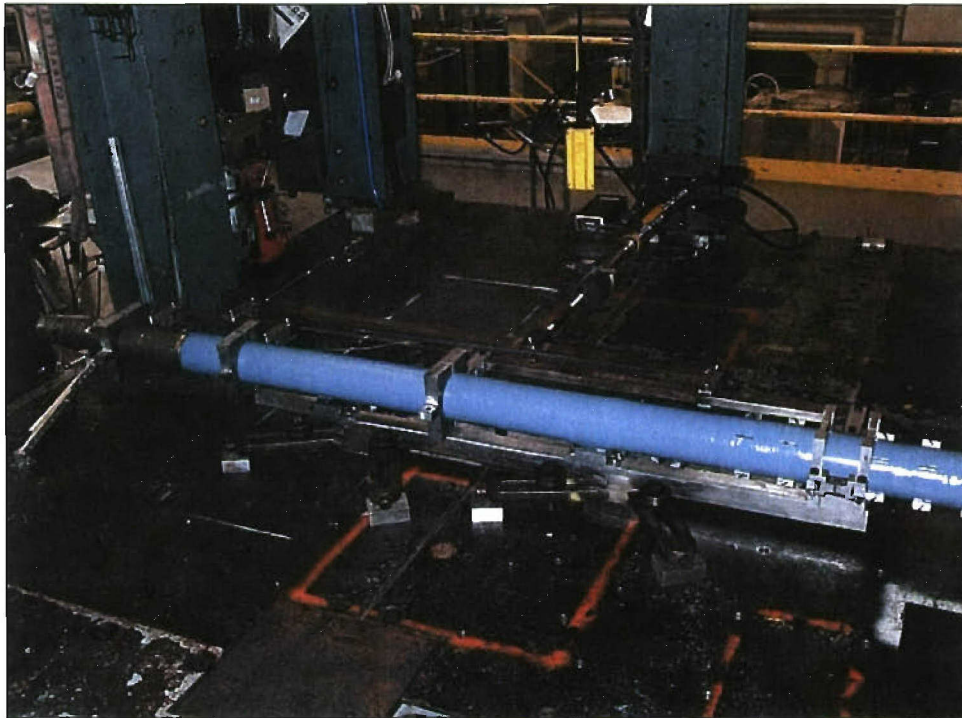
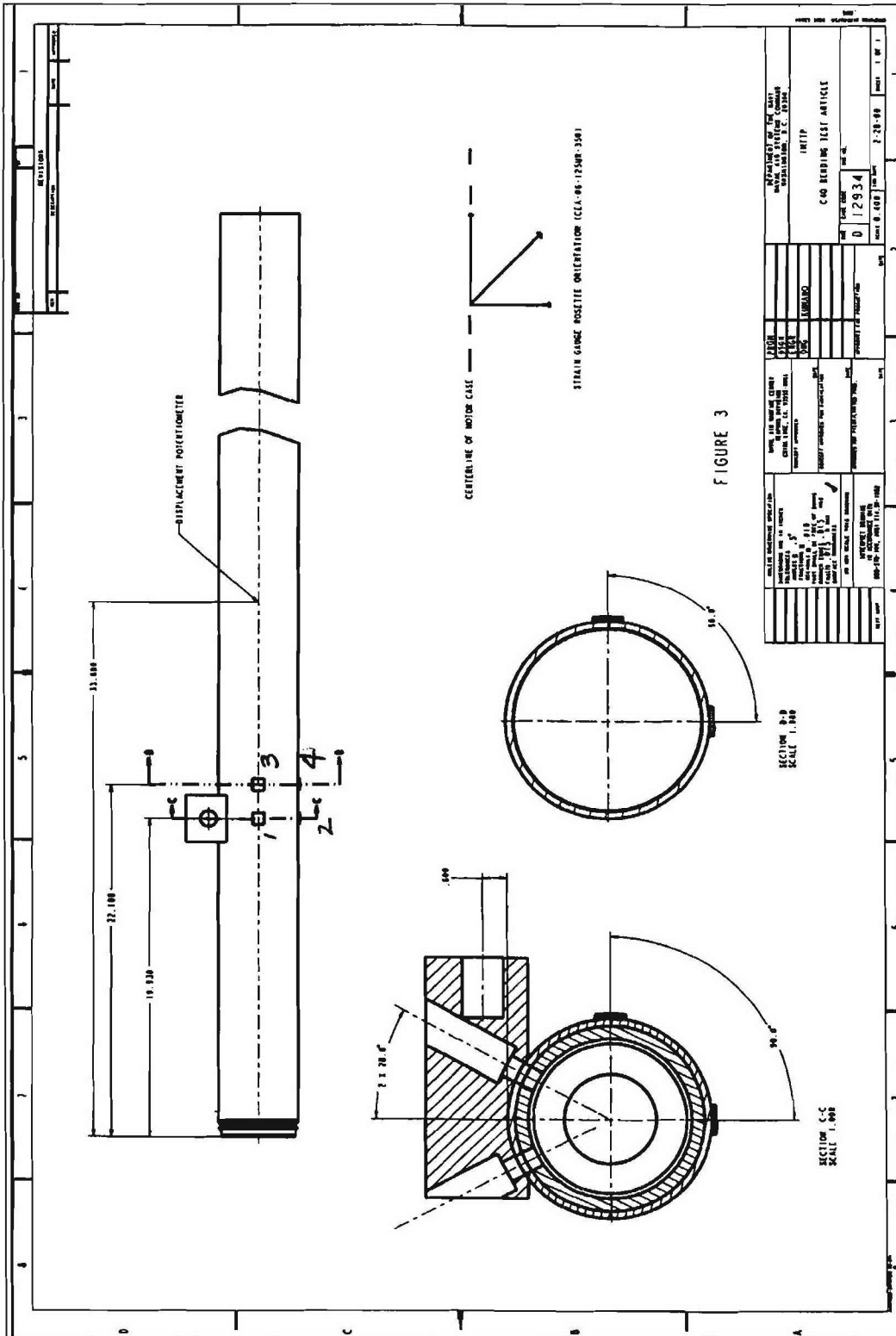

FIGURE V-1. Fixture Layout.

4.0 INSTRUMENTATION AND DATA REQUIREMENTS

All strain gages are 45-degree rectangular rosette (MM CEA-06-125 UR-350) gages. The placement of the instrumentation is shown in Figure V-2.



The accuracy requirements for the instrumentation through the data recording system shall be as shown in Table V-1.

TABLE V-1. Accuracy Requirements for Instrumentation.

Strain Gages	$\pm 0.08\%$ strain
Load Cell	± 10.0 lb

The test data shall be reduced and plotted. Two copies of all printouts and plots are required, as well as the bulk data. The digital listings (printouts) will have the strain and displacement as a function of load. Digital plotting will be in the format provided in Table V-2.

TABLE V-2. Digital Plotting Format.

Instrumentation	Abscissa	Ordinate
Load (shear load) cell	Time, seconds	0 to 5000 lb
Strain gages (SG1-SG12)	Time	-1.0 to 1.0%

5.0 TEST PROCEDURE AND SETUP

The types of gages are noted in Figure V-2. These gages must be protected and thermal compensation is not required. Prior to the tests, the test director will define selected priority data, which will be immediately processed and reviewed prior to proceeding with the testing.

The general test procedures are as follows.

1. Attach the launch rail simulator to the static test frame.
2. Attach the test article to the launch rail.
3. Attach the wiffle tree clamps to the test article in the locations shown.
4. Assemble the wiffle tree.
5. Attach the wiffle tree to the load jack.
6. Connect all instrumentation.
7. Take pretest photographs of the test setup.
8. Slowly raise the load to 1900 pounds (10 g) and then lower the load back to zero. Observe strain gage and displacement readings. Verify all instrumentation is operating properly.
9. Begin applying the load; continue until proof load of 6014 lbf (31g) is reached.
10. Inspect metal parts for signs of damage.
11. Inspect the composite structure for signs of damage.
12. Note all anomalies during and after the testing.
13. Take post-test photographs of the test setup.
14. Remove test article (see Sections 5.1 and 5.2).

5.1 TEST PRECAUTIONS

The composite tube will be placed in an isolated area during the test. Hazardous flying debris is possible and all precautions shall be taken to avoid exposure to the debris. Extreme care should be taken in handling of the case after the test is completed. All tests must comply with all Code 476300D safety requirements.

5.2 TEST ARTICLE DISPOSITION

The composite tube will be post inspected after the proof test by Code 476J00D personnel.

6.0 SUMMARY

Following the test, a summarized report shall be drafted describing the test and the results. Pertinent diagrams and graphs shall be included.

Appendix W
COMPOSITE CASE CAPTIVE CARRY QUALIFICATION (C⁴Q)
BLUE TUBE PRE-FLIGHT PROOF TEST REPORT

CONTENTS

1.0 Scope W-5

2.0 Discussion W-5

3.0 Proof Load Test W-5

4.0 Test Hardware W-10

5.0 Disposition of Hardware W-11

Figures:

W-1. Test Setup (View 1) W-6

W-2. Test Setup (View 2) W-6

W-3. Displacement Potentiometer Location W-7

W-4. Wiffle Tree Arrangement W-7

W-5. Load Versus Displacement for Blue Tube Serial Number 012 W-8

W-6. Load Versus Displacement for Blue Tube Serial Number 013 W-8

W-7. Load Versus Displacement for Blue Tube Serial Number 014 W-9

W-8. Load Versus Displacement for Blue Tube Serial Number 015 W-9

W-9. Load Versus Displacement for Blue Tube Serial Number 016 W-10

Tables:

W-1. Test Hardware W-10

1.0 SCOPE

This document contains the results of the proof load tests performed on the Composite Case Captive Carry Qualification (C⁴Q) tube. The testing was performed at the Naval Air Warfare Center Weapons Division, China Lake, California.

2.0 DISCUSSION

The proof load testing of the five C⁴Q tubes was performed in March and April 2001. The test articles consisted of the C⁴Q tubes as described in drawing number A476200D-132. The tubes tested were labeled as Serial Numbers 012, 013, 014, 015, and 016. The tests were performed in accordance with the pertinent test plan (Appendix V).

3.0 PROOF LOAD TEST

The tube was assembled into the test fixture as shown in Figures W-1 through W-3. The tube was mounted to a launcher simulator designed to match the stiffness of a LAU-7 launcher. The hydraulic actuator is attached to a wiffle tree fixture to apply the load to the tube (see Figure W-4). Displacement was measured at missile station 12. The tube was loaded to 6014 pounds (measured at the hydraulic actuator) and held at that pressure for approximately 10 seconds. The loading was applied once in only one direction (corresponding to the Z direction) to verify structural proof.

The load versus displacement plots for blue tubes Serial Numbers 012 through 016 are shown in Figures W-5 through W-9, respectively.

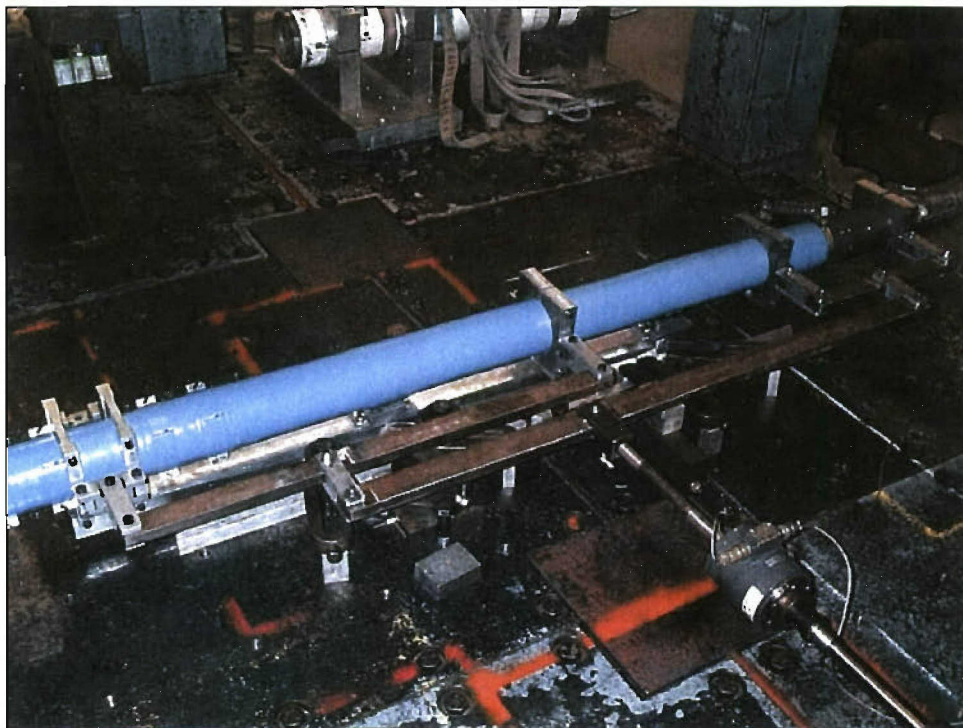

FIGURE W-1. Test Setup (View 1).

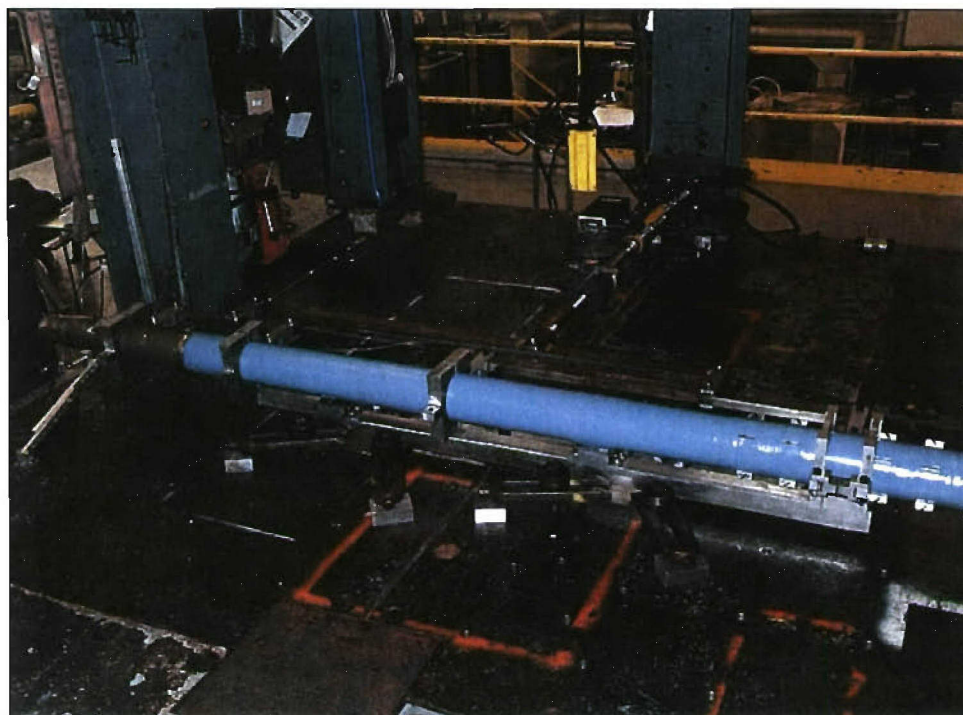

FIGURE W-2. Test Setup (View 2).

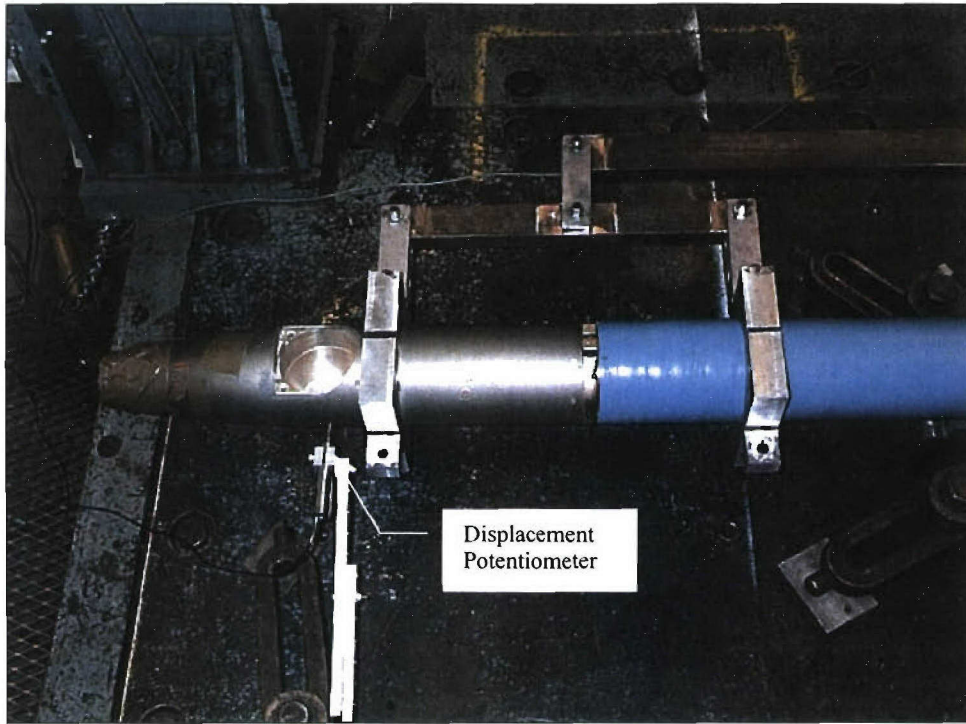

FIGURE W-3. Displacement Potentiometer Location.

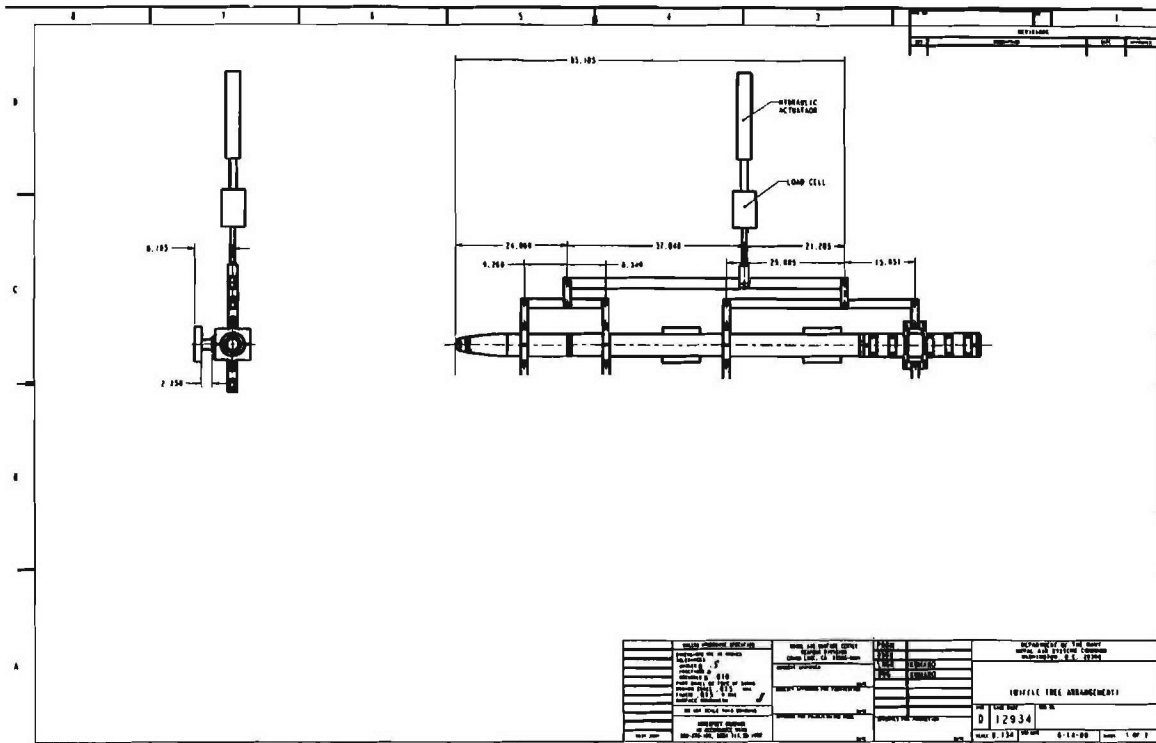

FIGURE W-4. Wiffle Tree Arrangement.

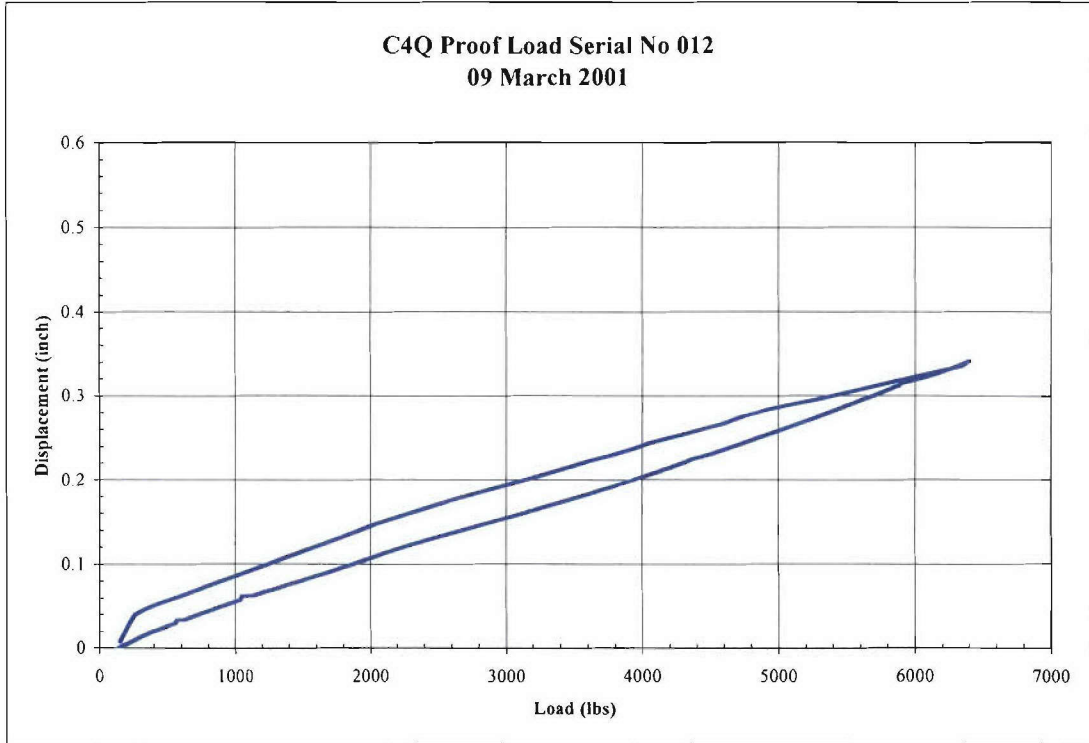

FIGURE W-5. Load Versus Displacement for Blue Tube Serial Number 012.

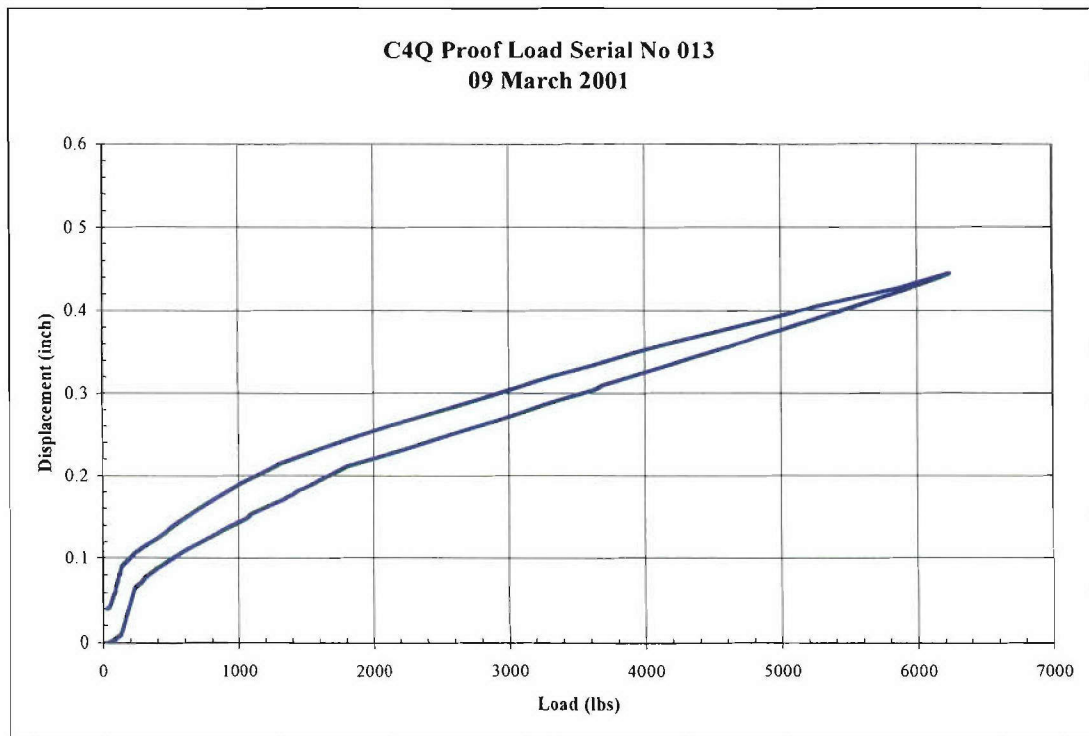

FIGURE W-6. Load Versus Displacement for Blue Tube Serial Number 013.

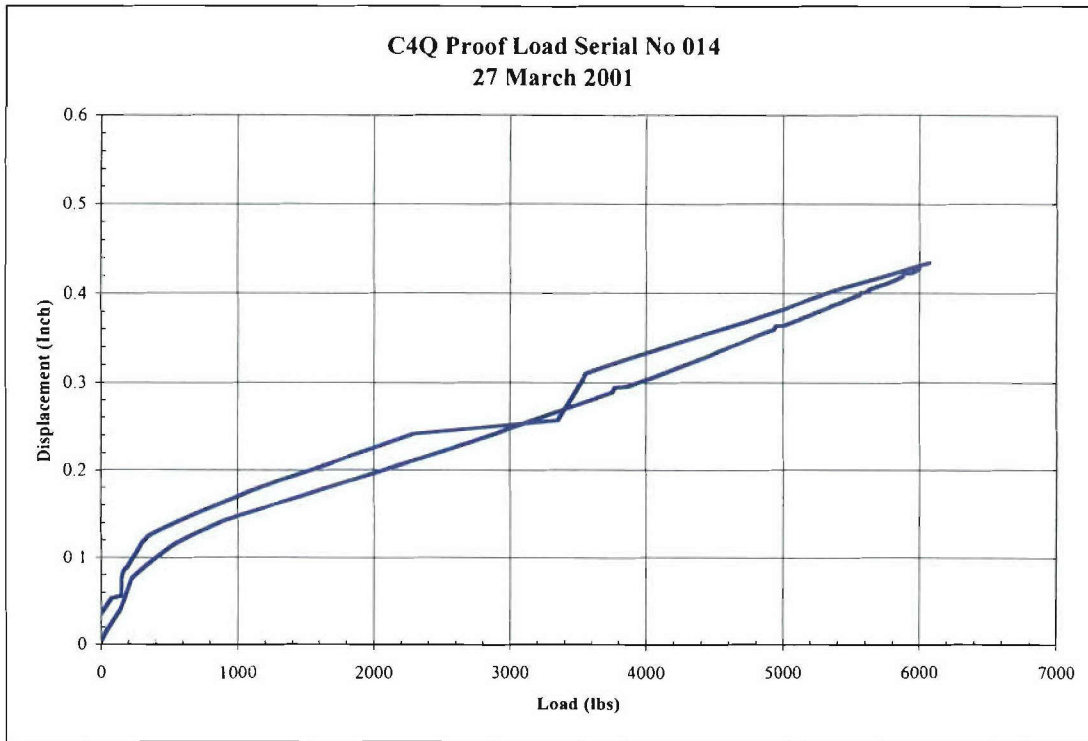

FIGURE W-7. Load Versus Displacement for Blue Tube Serial Number 014.

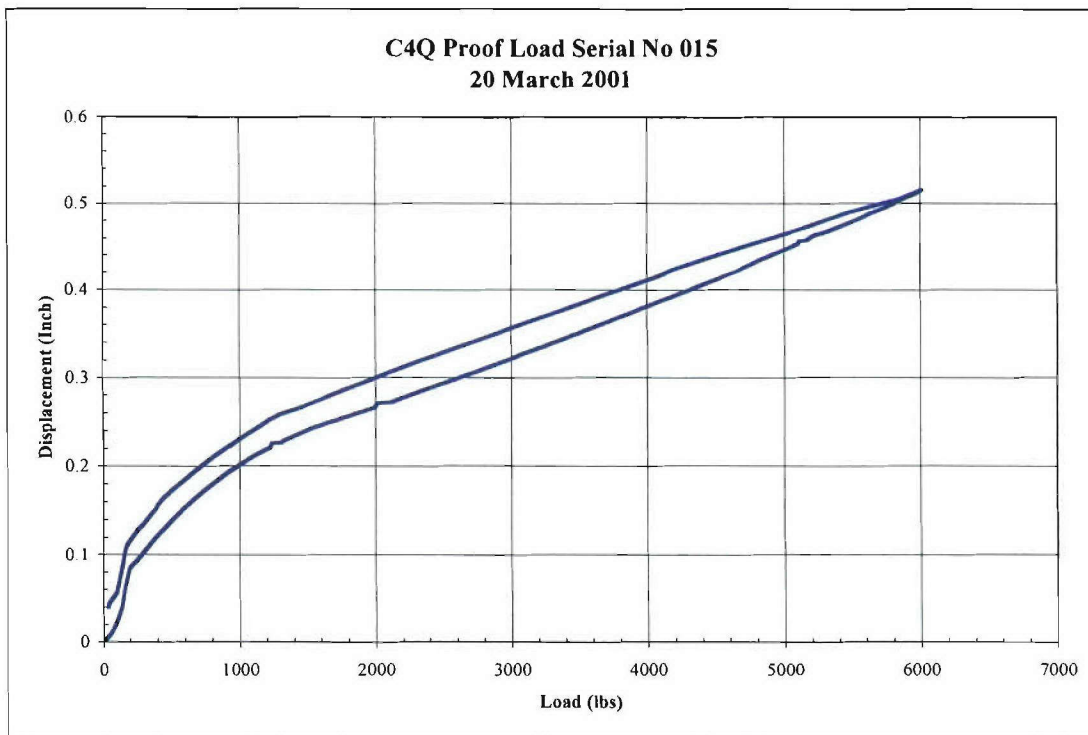

FIGURE W-8. Load Versus Displacement for Serial Number 015.

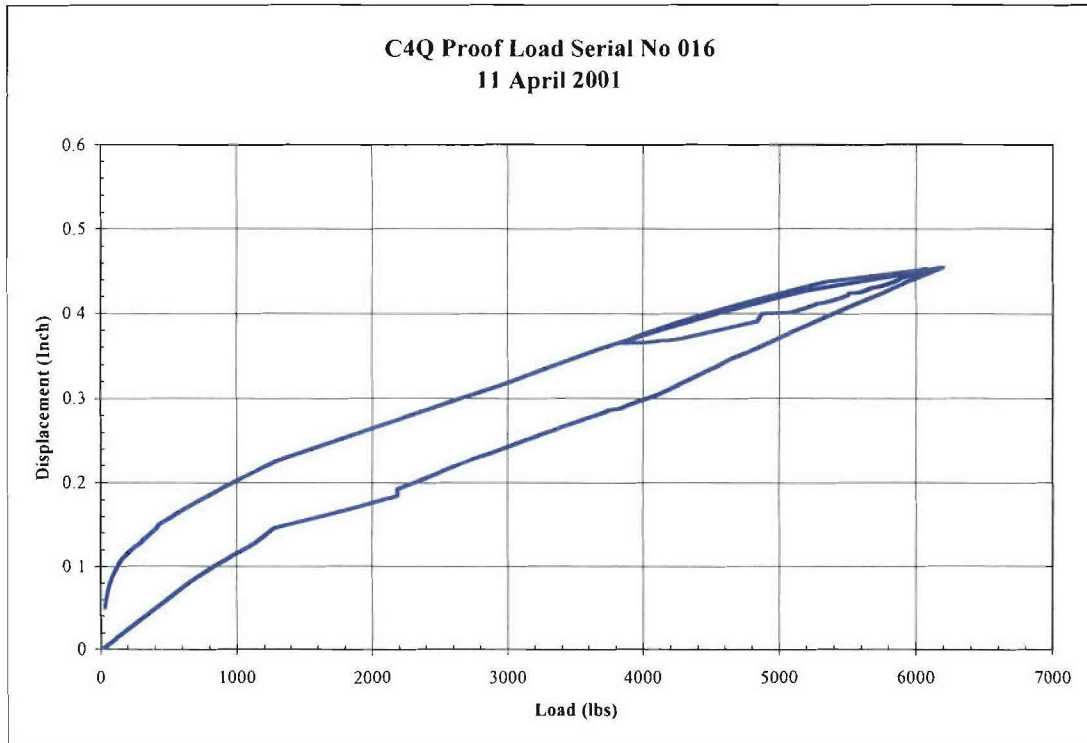

FIGURE W-9. Load Versus Displacement for Blue Tube Serial Number 016.

4.0 TEST HARDWARE

Table W-1 provides the test hardware.

TABLE W-1. Test Hardware.

Hardware	Model No./Serial No.	Calibration Due Date
LeBow load cell	3116-106/5227	6/17/01
Schlumberger data logger	SI 3531 D/100513	05/08/01
Wiffle Tree fixture	NA	NA
Enerpac hydraulic pump	PEM2045	NA
Enerpac hydraulic actuator	RD 1610	NA
HP DC power supply	6228B	NA
OMEGA Displacement Pot.	LD600-15/M922084A035-04	User Cal

5.0 DISPOSITION OF HARDWARE

The tubes were returned to Code 476J00D for post-test inspection. The details of this inspection are not included in this report.

Appendix X
COMPOSITE CASE CAPTIVE CARRY QUALIFICATION (C⁴Q) BLUE TUBE
TEST REPORT AND PLAN FOR BENDING TEST UNDER HOT/WET
CONDITIONS AND WITH OVERWRAP REMOVED

CONTENTS

Test Information..... X-5

Background..... X-5

Test Item Description..... X-5

Test Plan X-5

Temperature and Humidity Conditioning X-6

Test Setup..... X-6

Heating of Blue Tube..... X-9

Test Results X-11

Annex 1. Composite Case Captive Carry Qualification (C⁴Q) Blue Tube Test Plan for Bending
 Test After Unit Exposed to Hot/Wet Conditions and With Overwrap Removed..... X-17

Figures:

X-1. Setup (View 1)..... X-6

X-2. Setup (View 2)..... X-7

X-3. Post-test Photograph of Test Article (View 1)..... X-7

X-4. Post-test Photograph of Test Article (View 2)..... X-8

X-5. Failure Location..... X-8

X-6. Tube Surface Temperatures Before and During Loading (TC 101 to 106)..... X-9

X-7. Tube Surface Temperatures Before and During Loading (TC 107 to 112)..... X-10

X-8. Strain Gage 1 Yield Load..... X-11

X-9. Strain Gage 2 Yield Load..... X-12

X-10. Strain Gage 3 Yield Load..... X-12

X-11. Strain Gage 4 Yield Load..... X-13

X-12. Displacement During Yield Load..... X-13

X-13. Strain Gage 1 Ultimate and Failure Load..... X-14

X-14. Strain Gage 2 Ultimate and Failure Load..... X-14

X-15. Strain Gage 3 Ultimate and Failure Load..... X-15

X-16. Strain Gage 4 Ultimate and Failure Load..... X-15

X-17. Displacement During Ultimate and Failure Load X-16

Tables:

X-1. Thermocouple Locations..... X-10

TEST INFORMATION

Static loading was conducted on 26 March 2003 and temperature and humidity conditioning was performed on 18 February to 26 March 2003. The test was conducted at the Naval Air Warfare Center Weapons Division (NAWCWD) by Code 476300D on test item number Composite Case Captive Carry Qualification (C⁴Q) blue tube CATM-9M Serial Number 015 with inert fill.

BACKGROUND

The C⁴Q blue tube hot/wet bending test was a full-scale structural test of the composite blue tube in three-point bending. The goal was to simulate the worst-case bending load on the missile body. This test was intended to demonstrate the structural adequacy of the C⁴Q blue tube. Prior to the structural test, this blue tube had been subjected to a total of 8.88 hours of captive carry on the F/A-18C/D on both the pylon and wing tip stations when "cracks" were found on the external Kevlar layer.

TEST ITEM DESCRIPTION

The C⁴Q blue tube did not include the guidance and control section (GCS), wings, fins, and hangers. None of these items were considered necessary for this test. The forward hanger bolt holes were enlarged and a locating pin hole added per the instructions in the test plan. This allowed sufficient load to be applied to the composite case for it to fail in the composite section without failing at the forward hanger or spinning in the fixture.

TEST PLAN

The test plan is included as Annex 1. It contains the procedures and figures needed to execute the test. The test was performed in four stages. The first stage was to condition the blue tube in an environment with 85% relative humidity at 130°F (54.4°C). The second stage was to heat the blue tube to a temperature of 215°F (101.7°C). The third stage was to increase the load to the yield and back down to zero. The fourth stage was to increase the load to ultimate and then continue until failure.

TEMPERATURE AND HUMIDITY CONDITIONING

The test specimen was subjected to 85% relative humidity at 130°F for 36 days. The weight equilibrium changes were difficult to measure on the full-scale test article due to the extra weight of the metal components and inert fill. The initial weight was 133 pounds; the weight after conditioning was 133.1 pounds.

TEST SETUP

The specimen was loaded in a three-point bending fixture. The locations of the end clamping fixtures and load application point were designed to approximate the moment diagram during the worst-case bending maneuver. A block-like replacement for the forward hanger was used to simulate the load transfer through the forward hanger. The fixtures can be seen in Figures X-1 through X-5. Heating blankets and insulation were used to produce the elevated temperature for the test. The blue tube was instrumented with four rectangular rosette strain gages at the locations shown in the test plan.

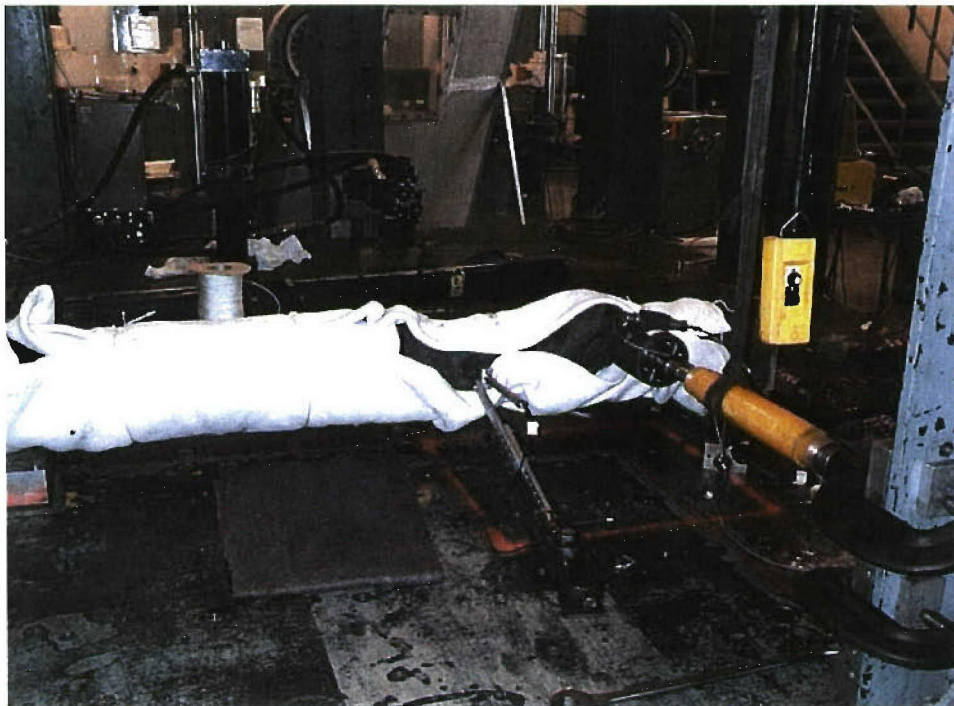

FIGURE X-1. Setup (View 1).



FIGURE X-2. Setup (View 2).

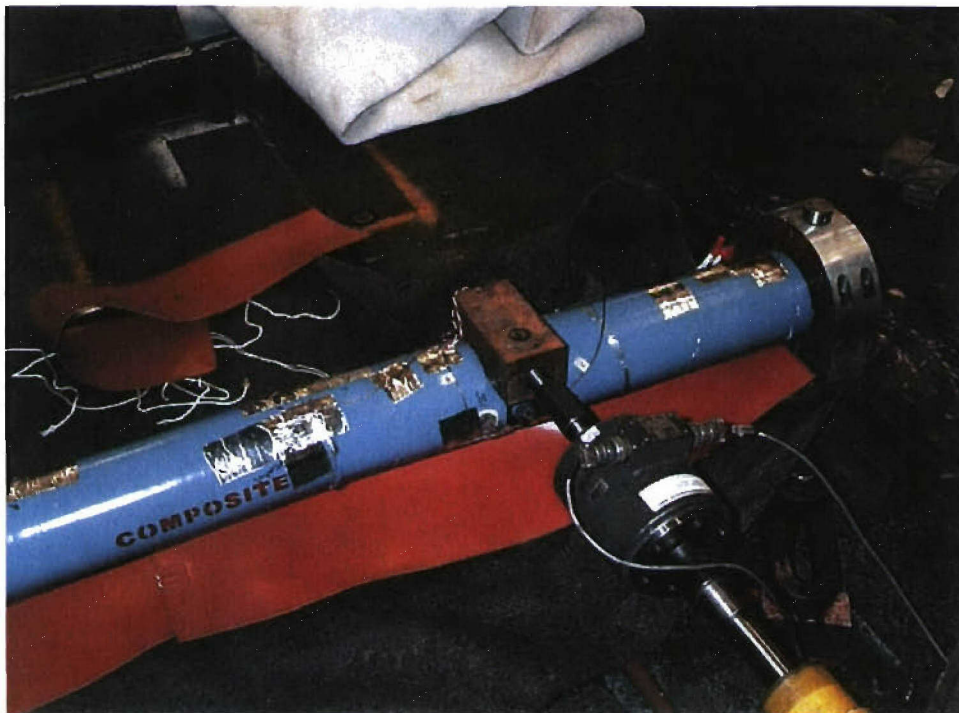

FIGURE X-3. Post-test Photograph of Test Article (View 1).

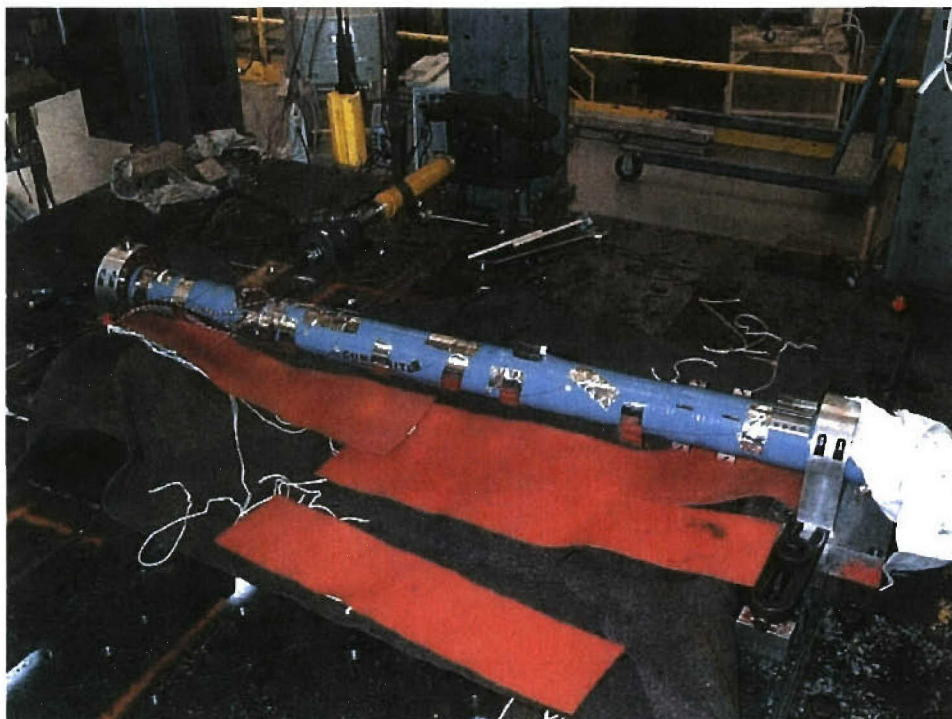

FIGURE X-4. Post-test Photograph of Test Article (View 2).

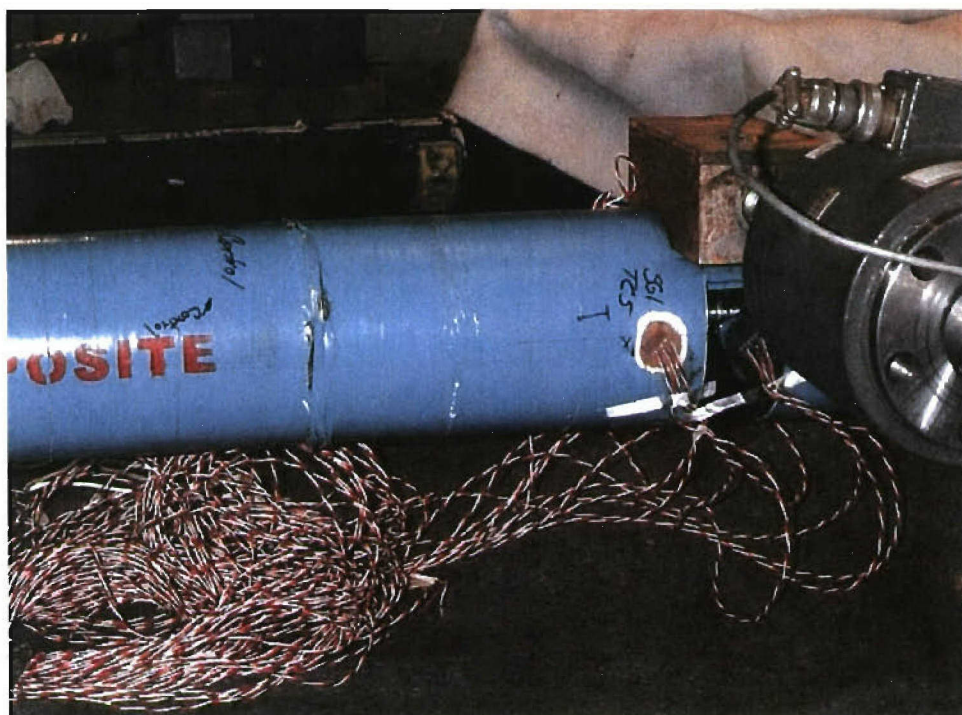

FIGURE X-5. Failure Location.

HEATING OF BLUE TUBE

To achieve the elevated temperature, the specimen was covered with heating blankets and insulation. The temperature was to be controlled to maintain 215°F. Due to the uneven heating along the length of the tube, the temperature was allowed to go as high as 257°F (125°C) at some locations. The temperature was reduced to 248°F (120°C) just prior to applying the loading. The heating profiles for prior to and during loading are shown in Figures X-6 and X-7. The thermocouple locations were as listed in Table X-1.

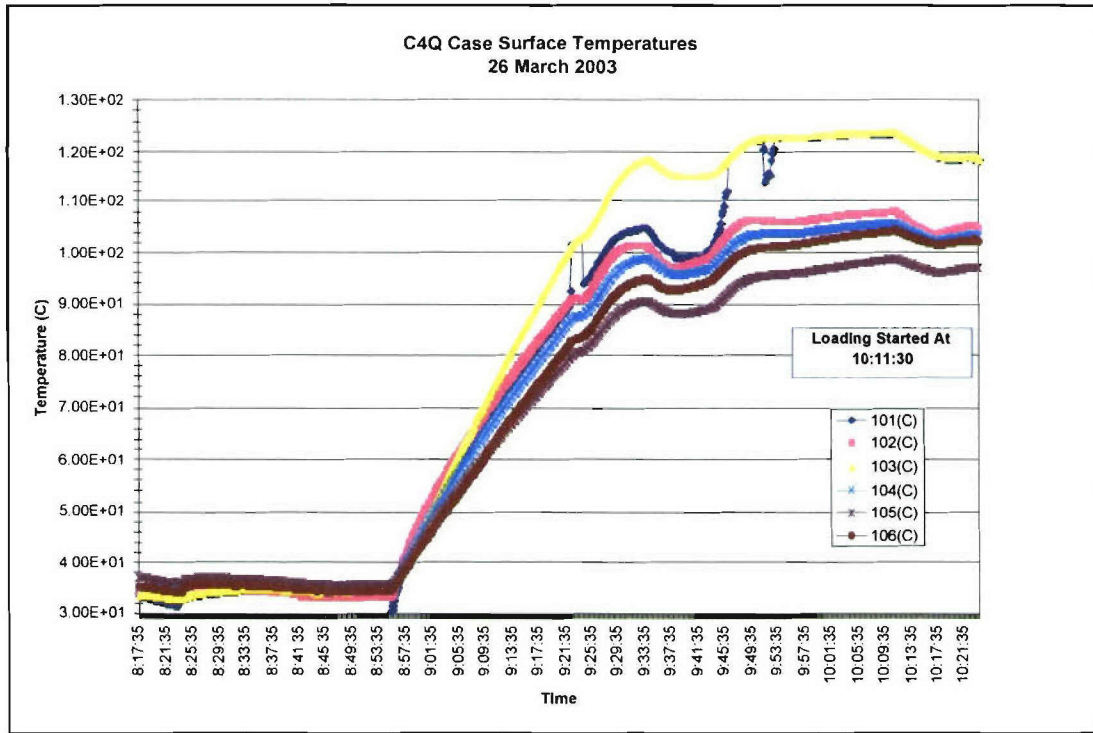

FIGURE X-6. Tube Surface Temperatures Before and During Loading (TC 101 to 106).

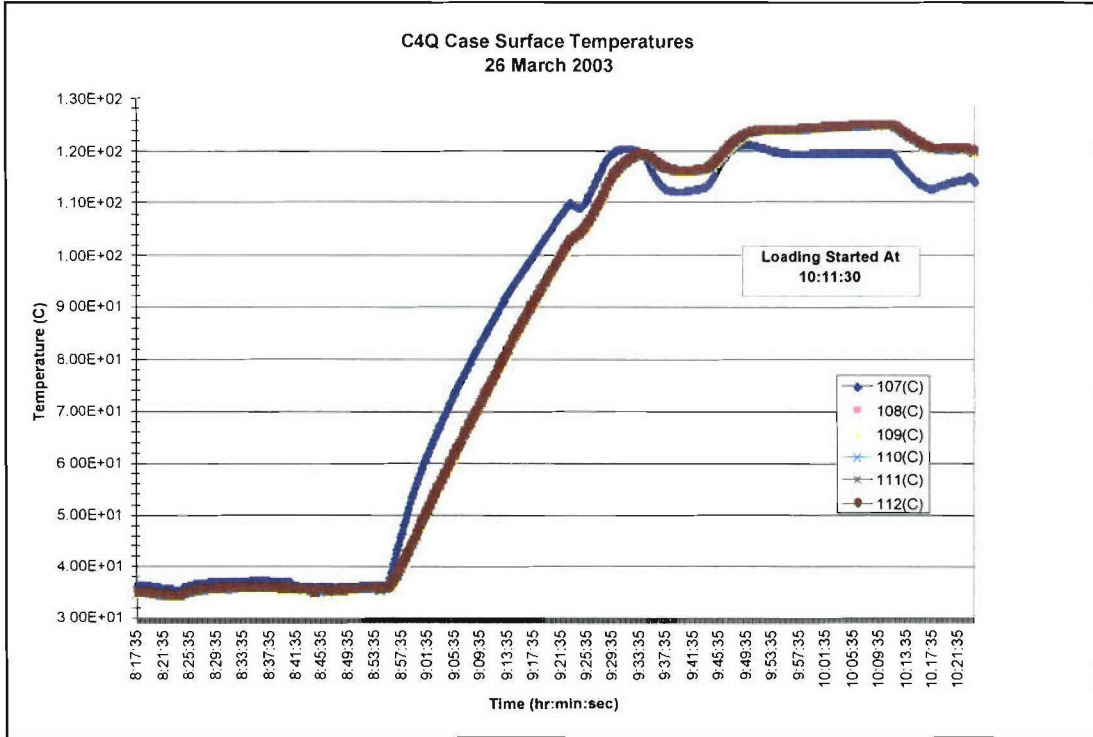

FIGURE X-7. Tube Surface Temperatures Before and During Loading (TC 107 to 112).

TABLE X-1. Thermocouple Locations.

Channel ID	InScan	Channel Name	Function
101	Yes	5 in Aft	Temp. (type T)
102	Yes	Near SG4	Temp. (type T)
103	Yes	Near SG2	Temp. (type T)
104	Yes	Near SG3	Temp. (type T)
105	Yes	Near SG1	Temp. (type T)
106	Yes	19 in Aft	Temp. (type T)
107	Yes	26 in Aft	Temp. (type T)
108	Yes	30 in Aft (control)	Temp. (type T)
109	Yes	41 in Aft	Temp. (type T)
110	Yes	47 in Aft	Temp. (type T)
111	Yes	55 in Aft	Temp. (type T)
112	Yes	71 in Aft	Temp. (type T)

TEST RESULTS

The loading was raised to yield level (7170 pounds) and returned to zero in order to confirm that no permanent deformation occurred. The strain and displacement data for the yield load sequence are shown in Figures X-8 through X-12. The loading was then raised to ultimate load (9355 pounds) and held for approximately 30 seconds. The load was then increased until it produced a failure. The maximum load was 12,990 pounds. The strain and displacement data for the ultimate and failure load sequence are shown in Figures X-13 through X-17. All fixtures and instrumentation performed as expected.

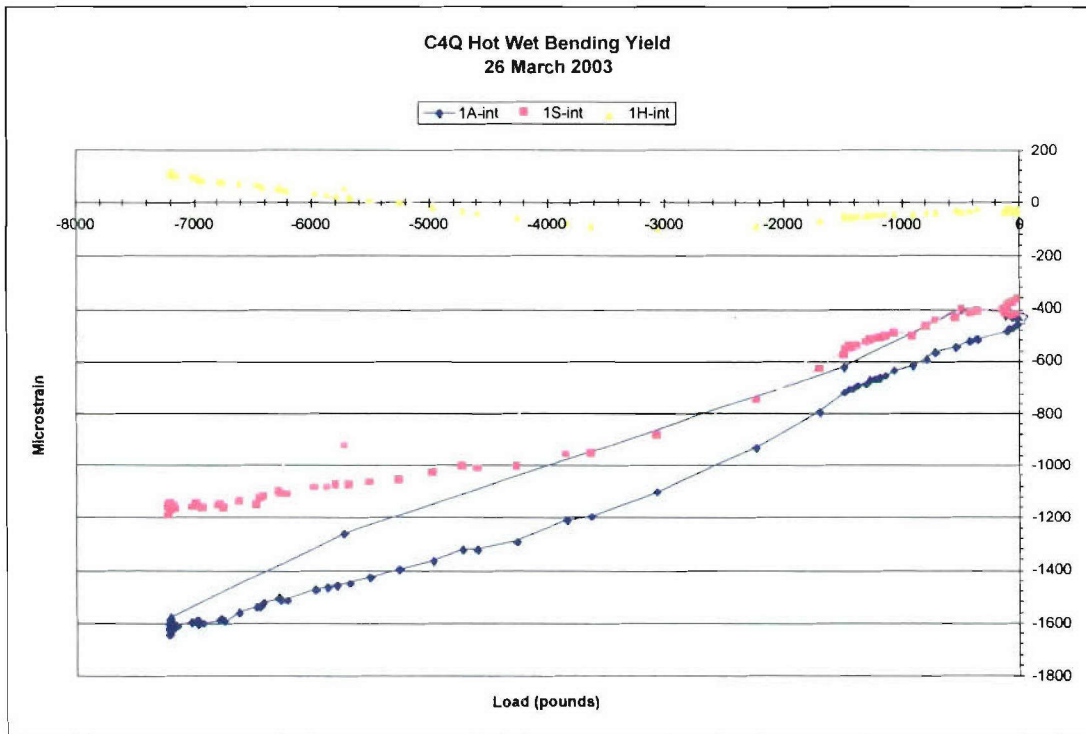

FIGURE X-8. Strain Gage 1 Yield Load.

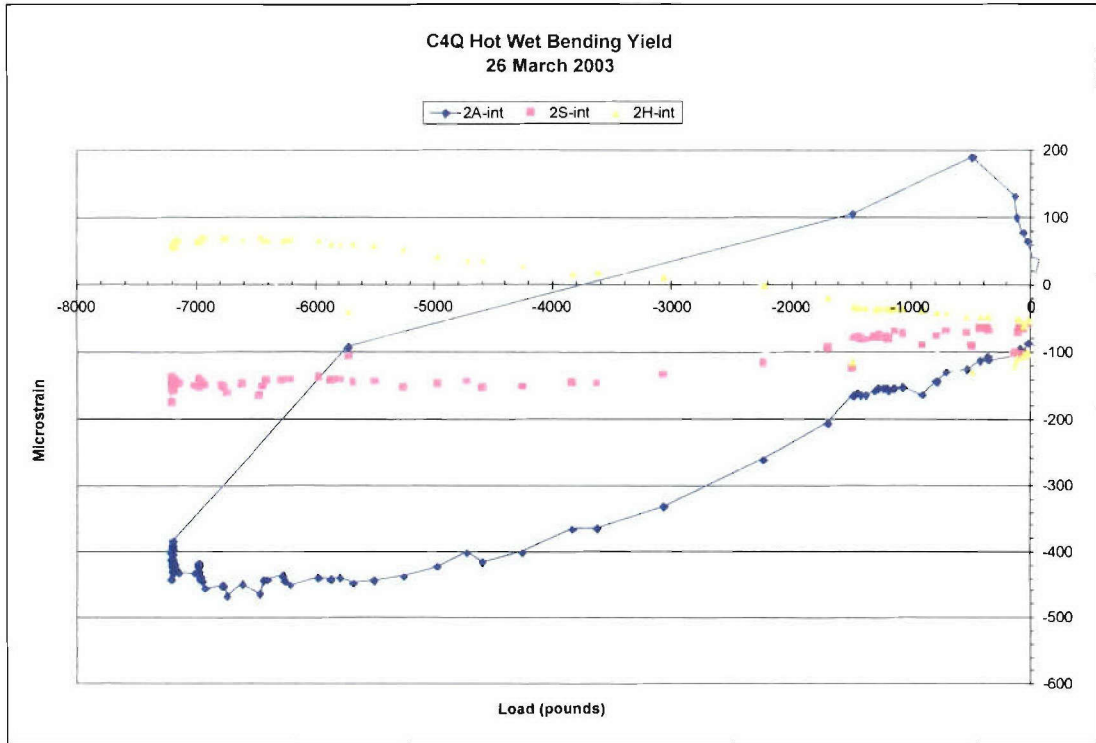

FIGURE X-9. Strain Gage 2 Yield Load.

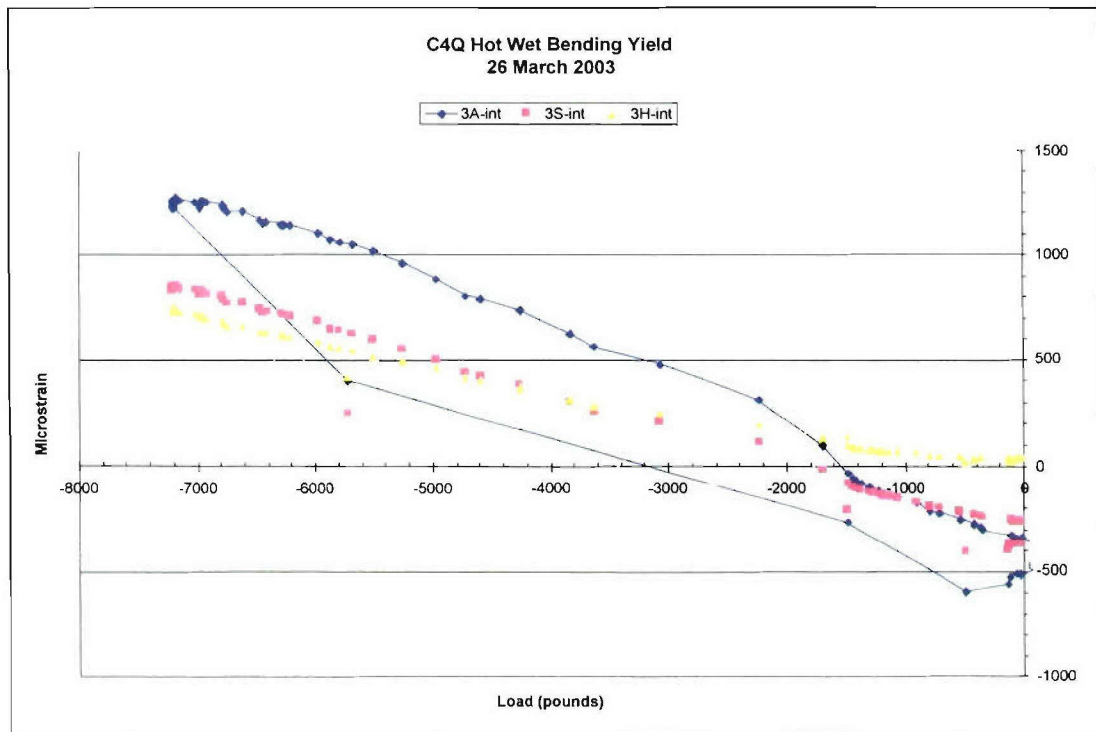

FIGURE X-10. Strain Gage 3 Yield Load.

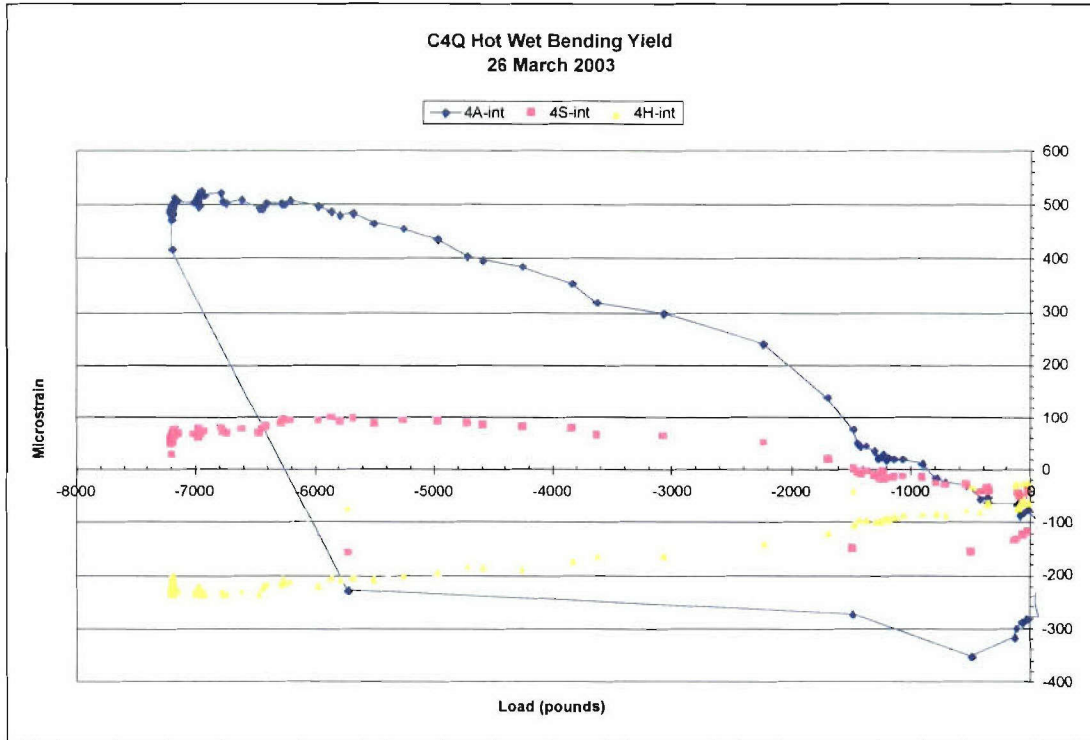

FIGURE X-11. Strain Gage 4 Yield Load.

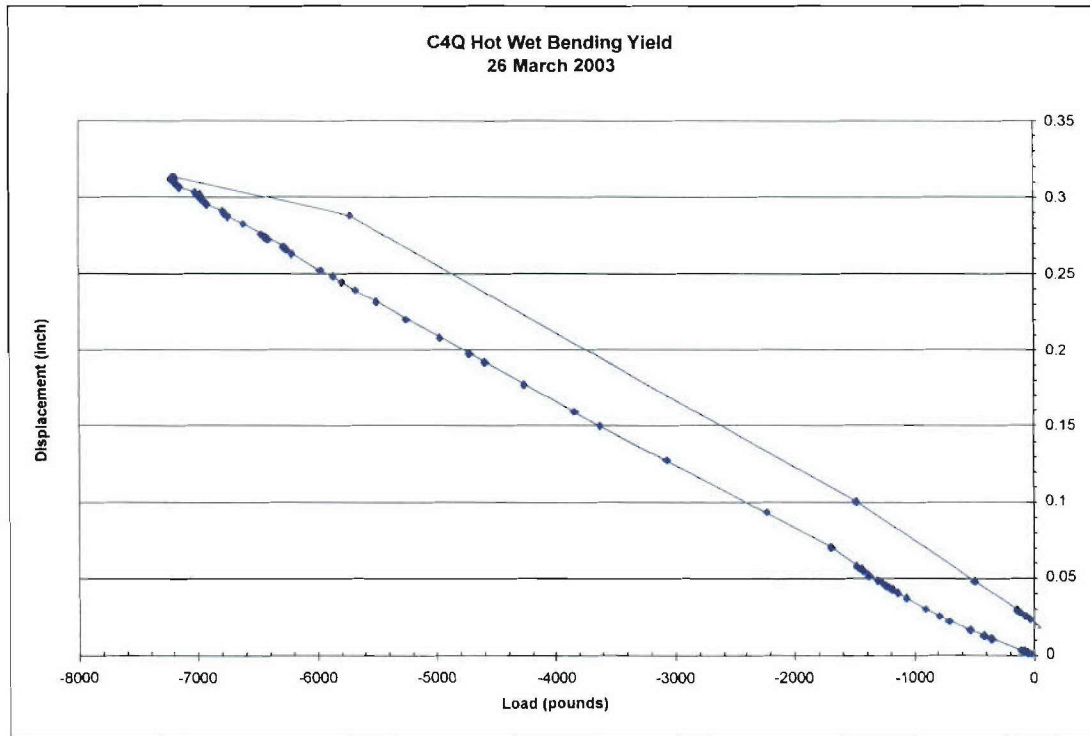

FIGURE X-12. Displacement During Yield Load.

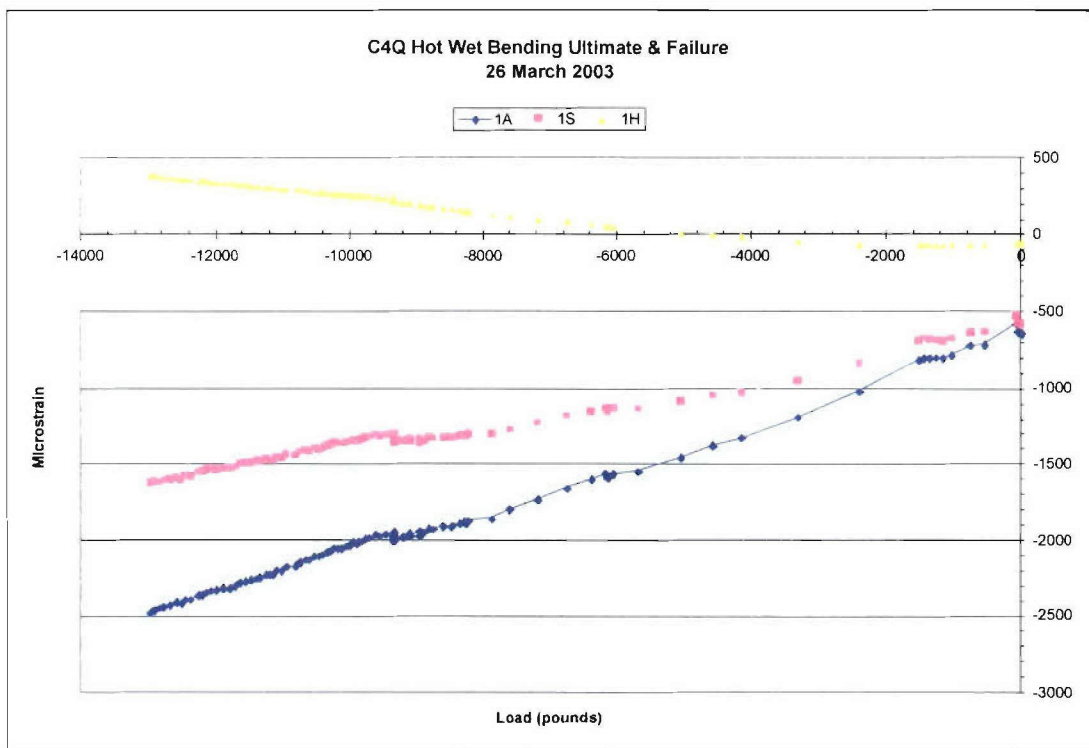

FIGURE X-13. Strain Gage 1 Ultimate and Failure Load.

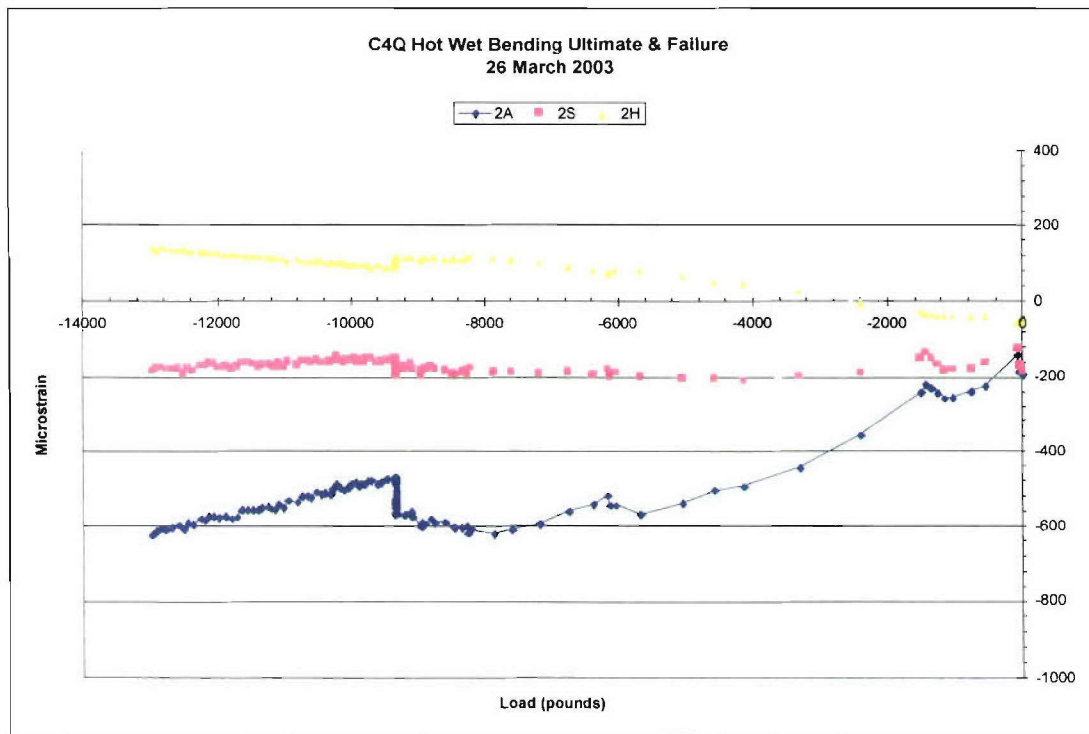

FIGURE X-14. Strain Gage 2 Ultimate and Failure Load.

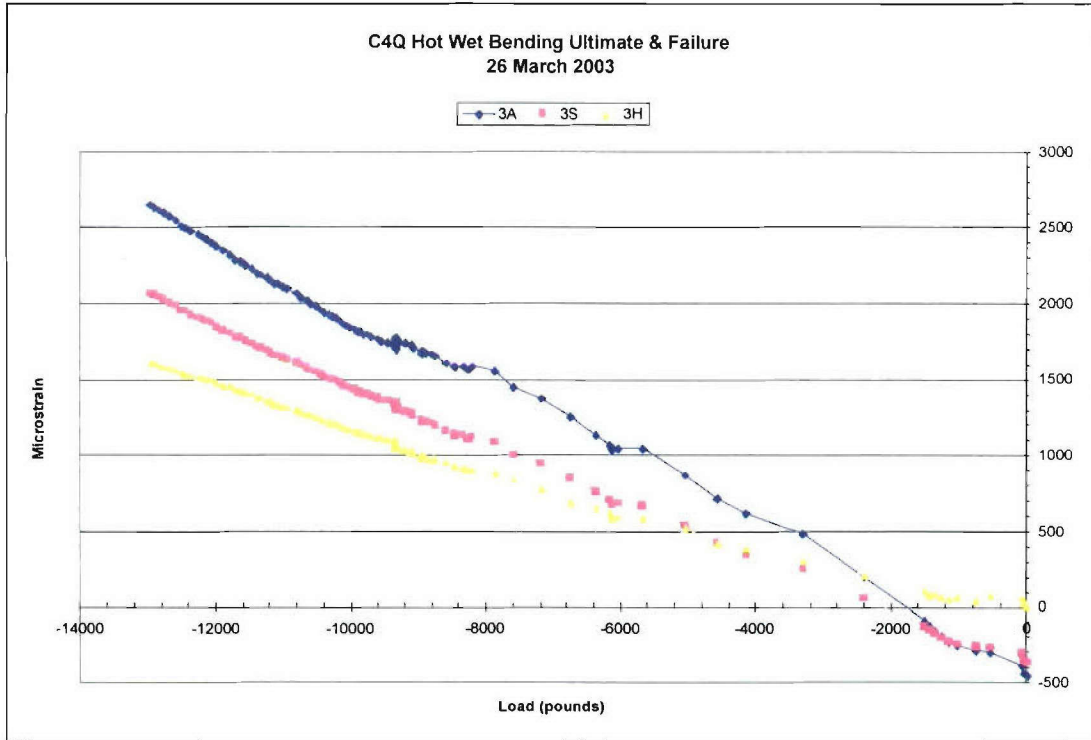

FIGURE X-15. Strain Gage 3 Ultimate and Failure Load.

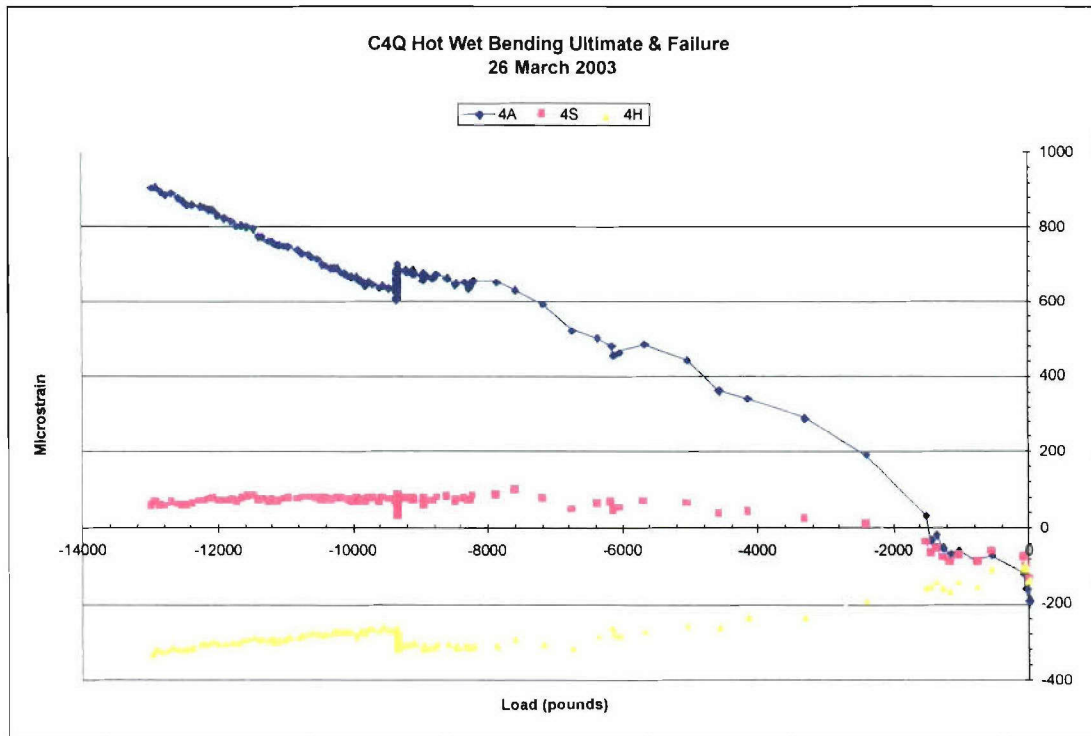

FIGURE X-16. Strain Gage 4 Ultimate and Failure Load.

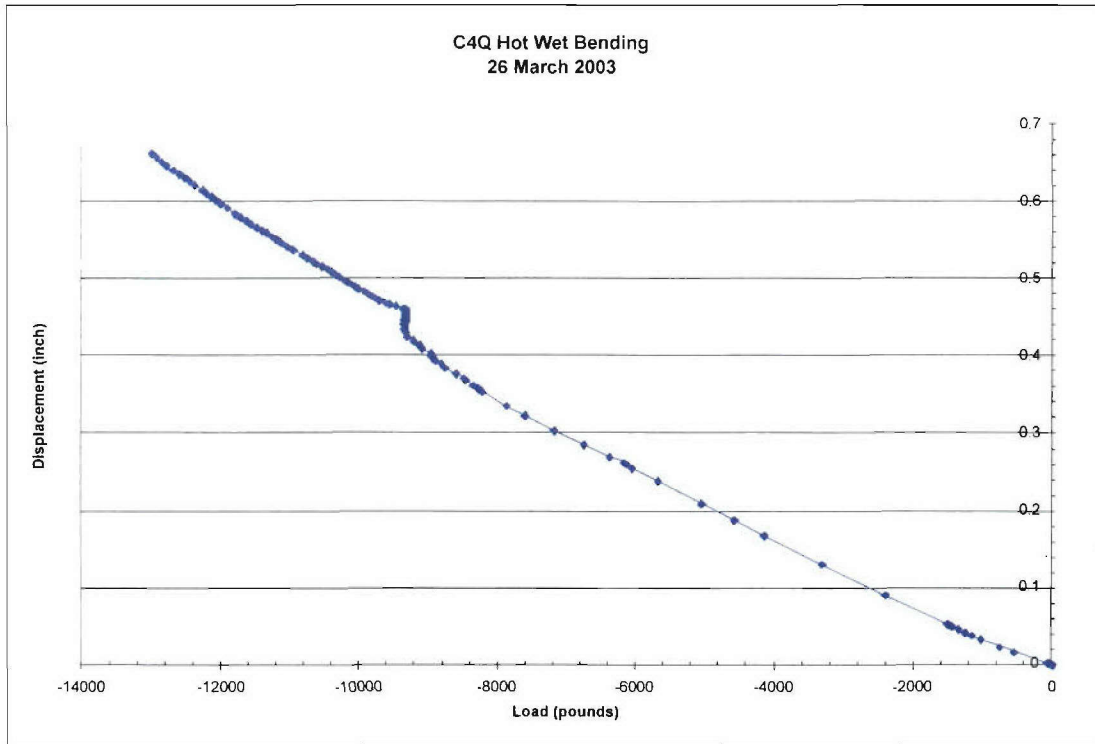

FIGURE X-17. Displacement During Ultimate and Failure Load.

Annex 1
COMPOSITE CASE CAPTIVE CARRY QUALIFICATION (C⁴Q) BLUE TUBE TEST
PLAN FOR BENDING TEST AFTER UNIT EXPLODED TO HOT/WET
CONDITIONS AND WITH OVERWRAP REMOVED

1.0 INTRODUCTION

This test plan describes the requirements of the Insensitive Munitions Technology Transition Program (IMTTP) Composite Case Captive Carry Qualification (C⁴Q) composite structural verification bending tests after exposure to a hot/wet environment. The composite tube has been subjected to captive carry flight. The tube will be conditioned in a hot/humid environment and then a bending test will be performed at elevated temperature.

2.0 OBJECTIVE

The primary purpose of this environment and loading test is to verify that the tube still meets design requirements after exposure to captive carry. This test plan provides the overall instructions for testing the IMTTP 5.0-inch composite tube specimen. It contains instructions for subjecting the test item to the humid environment. And, finally, it contains the instructions for performing the bending test at elevated temperature.

3.0 TEST DESCRIPTION

The test requirements, as defined by the loads given in the design, will be demonstrated via proof (yield) and ultimate testing.

Proof (yield) testing consists of applying limit loading (69,200 in-lb moment at missile station 44.0 inches) times a 1.15 factor for a total applied bending moment of 79,580 in-lb. Due to this test being performed without impact damage, the applied loading is then increased by the design knockdown factor of 1.25. This results in an applied moment of 99,475 in-lb. This value is denoted as the "composite yield load."

Ultimate testing consists of applying limit loading (69,200 in-lb moment at missile station 44.0 inches) times a 1.5 factor for ultimate (plus 1.25 for the knockdown), resulting in a total applied bending moment of 129,750 in-lb. This value is denoted as the "composite ultimate load."

The success criteria are as follows. Proof (yield) testing shall be considered successful if the case withstands proof moment without anomalous behavior that would be indicative of its inability to perform its intended use. This shall be determined by inspection (visual and dimensional) and comparison of data (strains and deflections) with other composite case designs.

Ultimate bending moment testing shall be considered successful if the case fails in the predicted manner at 1.5 or higher load factor.

3.1 TEST ARTICLE DESCRIPTION

The test article consists of an IMTTP C⁴Q composite tube (Serial Number 015) as described in drawing number A476200D-126 (C4Q FIRST CURED ASSY). The test article consists of the warhead section and composite tube. The composite tube is filled with a urethane/tungsten mix to simulate rocket motor propellant. The cases are wound using IM-7 graphite fiber embedded in an epoxy resin. The graphite/epoxy winding lay-up consists of helical (14-degree), axial (0-degree), and hoop (90-degree) layers. A Kevlar overwrap hoop layer is used for protection. A 3/4-inch hole for a pin is added as shown in Figure Annex1-1. (Note: All of the figures are provided at the end of this annex.) The holes for the forward hanger are opened up to 1/2-inch clearance holes (see section C-C on Figure Annex1-2).

3.2 TEST FACILITIES

The test facility is located at the Code 476300D environmental laboratory. Bending moment tests will be done on the static frame, while the hot/wet environment conditioning will be done in the large (Sexton) temperature and humidity chamber.

The test equipment for the bending moment test consists of a hydraulic load jack, load cell, strain gages, a displacement transducer, and signal conditioning and recording equipment. The test equipment for the hot/wet environment conditioning consists of the large temperature and humidity chamber, flexible heater with controller, and thermocouples.

The test fixturing to be used for the bending test will include two tie-down collars (one with a 0.75-inch pin at 12 o'clock) and a forward hanger replacement block. The layout of the test fixtures is shown in Figure Annex1-1.

4.0 INSTRUMENTATION AND DATA REQUIREMENTS

The instrumentation requirements for these tests will be the same for both proof (yield) and ultimate tests. All strain gages are 45-degree rectangular rosette (MM CEA-06-125 UR-350) gages.

The accuracy requirements for the instrumentation through the data recording system shall be as shown in Table Annex1-1.

TABLE Annex1-1. Accuracy Requirements for Instrumentation.

Strain Gages	±0.08% strain
Load Cell	±10.0 lb
Displacement Potentiometers	±0.01 inch
Thermocouples	±5°F

The test data shall be reduced and plotted at five samples per second. Two copies of all printouts and plots are required. The digital listings (printouts) will have the strain and displacement as a function of load. Digital plotting will be in the format provided in Table Annex1-2.

TABLE Annex1-2. Digital Plotting Format.

Instrumentation	Abscissa	Ordinate
Load (shear load) cell	Time, seconds	0 to 20,000 lb
Strain gages (SG1-SG12)	0 to 20,000 lb	-3.50 to 3.50%
Displacement potentiometer (DP1)	0 to 20,000 lb	0 to 0.70 inch
Thermocouples	Time, minutes	0 to 300°F

5.0 TEST PROCEDURE AND SETUP

5.1 HOT/WET ENVIRONMENT CONDITIONING OF TEST ARTICLE

Composite materials, when exposed to high humidity for prolonged periods, absorb moisture, which adversely affects the mechanical properties. High temperatures also have a negative effect. Consequently, this test will condition the composite test sample in a chamber at 85% relative humidity and 130°F for several weeks until moisture equilibrium is achieved. The sample will then be heated to 215°F for a minimum of 6 minutes (worst F-18C/D wing tip aero-heat temperature) and subjected to the bending moment tests to assess the effect of moisture absorption and elevated temperature.

The general moisture conditioning procedure is as follows.

1. Weigh tube to determine the as-received weight.
2. Place tube in temperature/humidity chamber and initiate test conditions of 85% relative humidity at 130°F.
3. Maintain tube at conditions for 4 weeks. Weigh tube to determine the conditioned weight.
4. Determine if moisture equilibrium has been reasonably approached. If not, continue conditioning. Otherwise, proceed to bending moment tests.

5.2 BENDING MOMENT TESTS

The type and orientation of the gages are noted in Figure Annex1-2. These gages must be protected. Thermal compensation is required as the flexible heater encasing the tube will be maintaining a temperature of 215°F. Prior to the tests, the test director will define selected priority data, which will be immediately processed and reviewed prior to proceeding with the testing. Maintaining the moisture content from the preconditioning is important. The test should be set up and performed in as short a period of time as possible (definitely on the same day).

The general test procedures are as follows.

1. Remove test article from the humidity chamber.
2. Place the assembly into the static test frame.
3. Attach the load actuator stinger to the forward hanger replacement block.
4. Attach the aft collar tie assembly to the aft section of the composite tube.
5. Align the forward collar and insert the pin through the collar and tube.
6. Locate displacement potentiometer according to Figure Annex 1-2.
7. Install thermocouples onto tube. One thermocouple shall be installed next to each strain gage. The control thermocouple shall be installed 30 inches aft of the forward fixture pin. The temperature will also be monitored at locations 5, 19, 26, 41, 47, 55, and 71 inches aft of the forward fixture pin.
8. Connect all instrumentation.
9. Cover composite tube with flexible heater and stabilize test item at 215°F (+10/-0).
10. Take pretest photographs of the test setup.
11. Slowly raise the load to 1000 pounds and then lower the load back to zero. Observe strain gage and displacement readings. Verify all instrumentation is operating properly.
12. Once correct instrumentation operation has been confirmed, start recording data and begin to raise the load in accordance with Figure Annex 1-3. Note the steps in the loading to allow for instrument stabilization.
13. Turn off instrumentation and disconnect all lead wiring and fixtures.
14. Note all anomalies during and after the testing.
15. Take post-test photographs of the test setup.
16. Remove test article (see Sections 5.3 and 5.4).

5.3 TEST PRECAUTIONS

The composite tube will be placed in an isolated area during the test. Hazardous flying debris is expected during the ultimate test and all precautions shall be taken to avoid exposure to the debris. Extreme care should be taken in handling the remains of the case after the test is completed. All the bending moment tests must comply with all Code 476300D safety requirements.

5.4 TEST ARTICLE DISPOSITION

The composite tube with inert fill will be post inspected after proof and ultimate tests by Code 476J00D personnel. The tube will be delivered to Code 476J00D for sectioning into coupons and cylindrical test articles after the ultimate test.

6.0 SUMMARY

Following this bending moment test, a summarized report shall be drafted describing the test and the results. Pertinent diagrams and graphs shall be included.

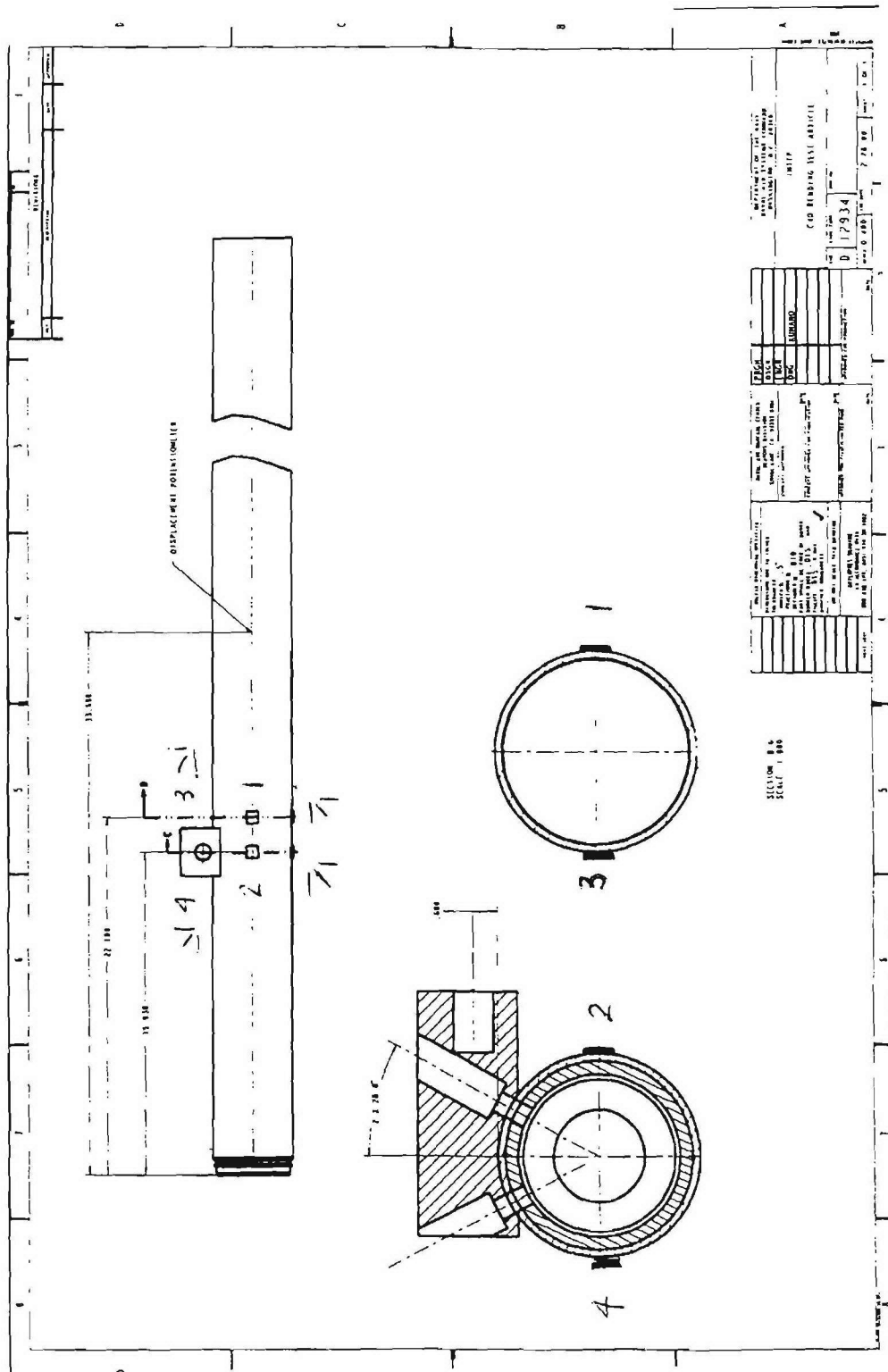
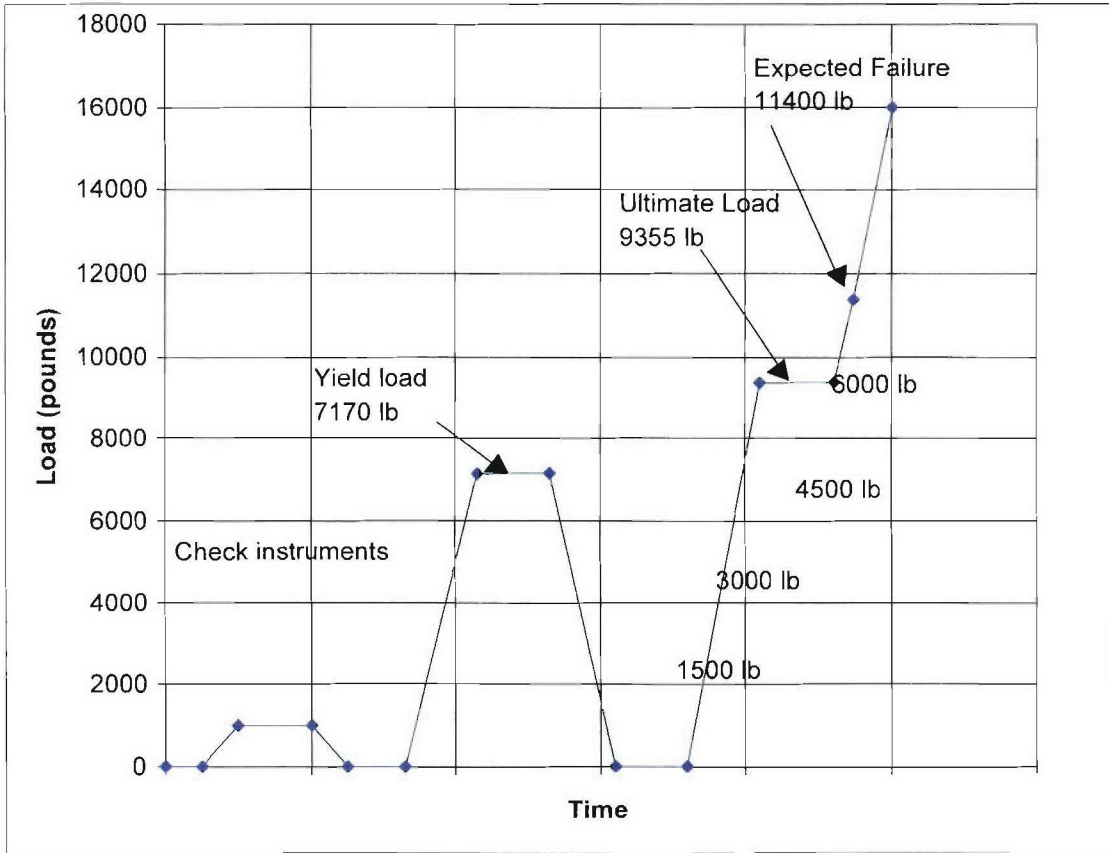

FIGURE Annex1-2. Orientation and Placement of Gages.



	Applied Load, pounds	Resulting Moment, in-lb	Strain, inches/inch	Maximum Displacement, inches
Instrument test	1,000	13,870	0.000241	0.044
Actual yield load	5,738	79,586	0.001383	0.250
Actual ultimate load	7,490	103,886	0.001805	0.327
Composite yield load	7172	99,475		
Composite ultimate load	9,355	129,750		
Predicted failure	11,400			

FIGURE Annex1-3. Load Schedule.

Appendix Y
COMPOSITE CASE CAPTIVE CARRY QUALIFICATION (C⁴Q) BLUE
TUBE SERIAL NUMBER 015 SURFACE INVESTIGATION REPORT

CONTENTS

Executive Summary Y-5

Inspection Process Y-5

Figures:

Y-1. Area of Removal for Crack Inspection (View 1) Y-5
Y-2. Area of Removal for Crack Inspection (View 2) Y-6
Y-3. Two “Chips” Removed From Overwrap Y-6
Y-4. Close-up of Top Portion of Removed Section (6.5X Magnification) Y-7
Y-5. Close-up of Top Portion of Removed Section (26X Magnification) Y-7
Y-6. Fracture Surface of Left Chip (26X Magnification) Y-8
Y-7. Fracture Surface of Right Chip (26X Magnification) Y-8
Y-8. Cut Surface of Right Chip (26X Magnification) Y-9
Y-9. SEM Micrograph Showing Fracture Surface of Right Chip (150X Magnification) Y-9
Y-10. SEM Micrograph Showing Fracture Surface of Right Chip (600X Magnification) Y-10
Y-11. SEM Micrograph Showing Cut Surface of Right Chip (150X Magnification) Y-10
Y-12. SEM Micrograph Showing Cut Surface of Right Chip (600X Magnification) Y-11
Y-13. Collage Image Showing Cross Section of Right Chip Y-12
Y-14. Indication 1 Showing Possible Separation of Kevlar Tows (200X Magnification) Y-13
Y-15. Indication 2 Showing Possible Separation of Kevlar Tows (200X Magnification) Y-13

EXECUTIVE SUMMARY

Further examination of surface cracks on blue tube Serial Number 015 has been completed. A small section of the Kevlar/resin overwrap was removed to inspect the carbon fiber surface directly below one of the surface cracks. No evidence was found of crack propagation into the carbon fiber.

INSPECTION PROCESS

A section of the overwrap measuring 0.55 inch by 0.75 inch was removed in the area of the deepest measured crack, approximately 15 inches from the forward end of the tube and 180 degrees from the hangers (Figures Y-1 and Y-2). The ends of the crack are located near the top of Figure Y-1, about 90 degrees from the removed section, and are separated by approximately 0.40 inch. The crack depth in this location was previously measured as 0.0144 inch via optical techniques. The section removed had the crack running through the middle of it, resulting in two "chips" (Figure Y-3). The chips were easily removed in that they did not appear to be well bonded to the underlying surface. The thickness of each chip was measured with digital calipers in four locations. The average thickness of the left chip was 0.0177 inch and the average thickness of the right chip was 0.0183 inch.

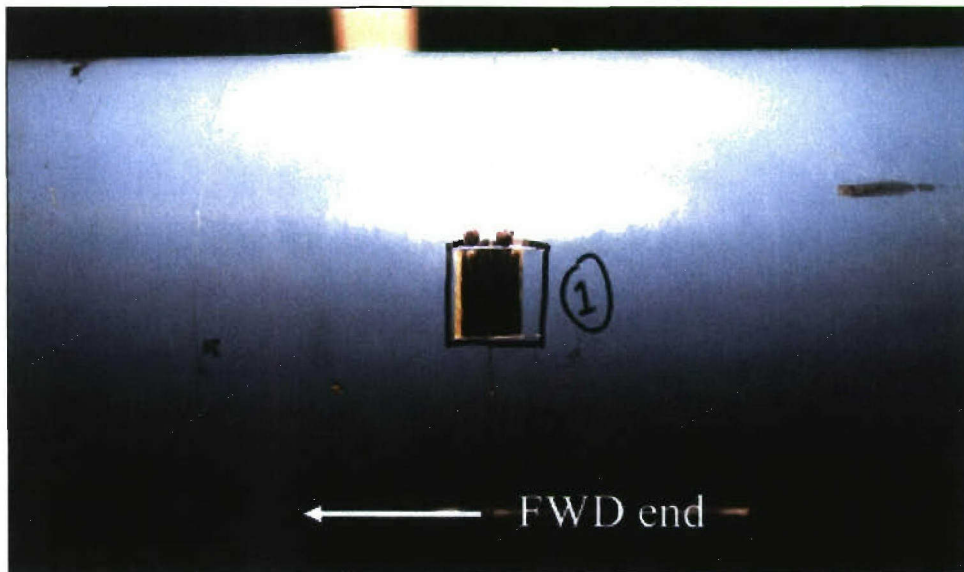

FIGURE Y-1. Area of Removal for Crack Inspection (View 1). (Ends of crack are located on the tube near the top of the figure).

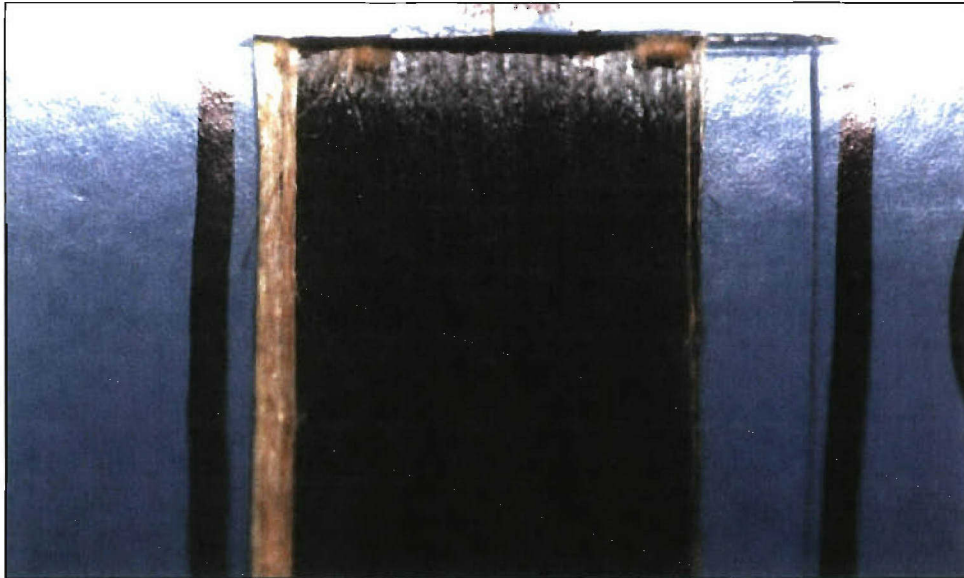

FIGURE Y-2. Area of Removal for Crack Inspection (View 2). (Removed width is 0.55 inch.)

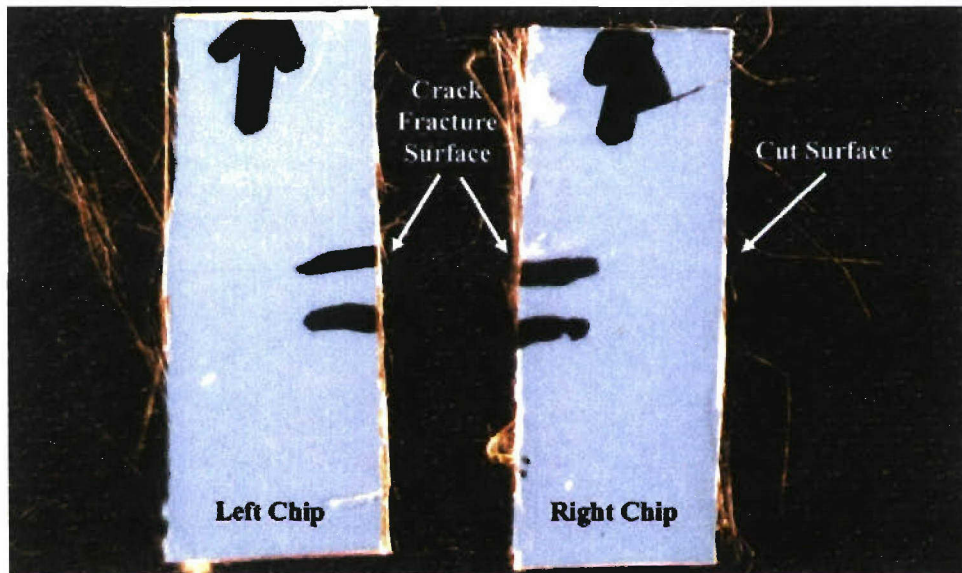

FIGURE Y-3. Two "Chips" Removed From Overwrap.

Visual inspection of the underlying carbon fiber surface revealed no apparent cracks (Figure Y-2). There was no indication of the moisture barrier on the carbon fiber or the bottom side of the chips. The surface was then inspected under higher magnification up to 26X (Figures Y-4 and Y-5). Again, no indication was found of crack propagation from the overwrap layers into the carbon fibers. It was found, however, that some damage to the surface was caused during scoring of the overwrap layers (Figure Y-5). The damage is only in the axial direction because heavier scoring was needed to cut through the Kevlar fibers. The scoring in the circumferential direction was light, only enough to penetrate the paint and resin-rich layers. The depth of the score marks is unknown at this time.

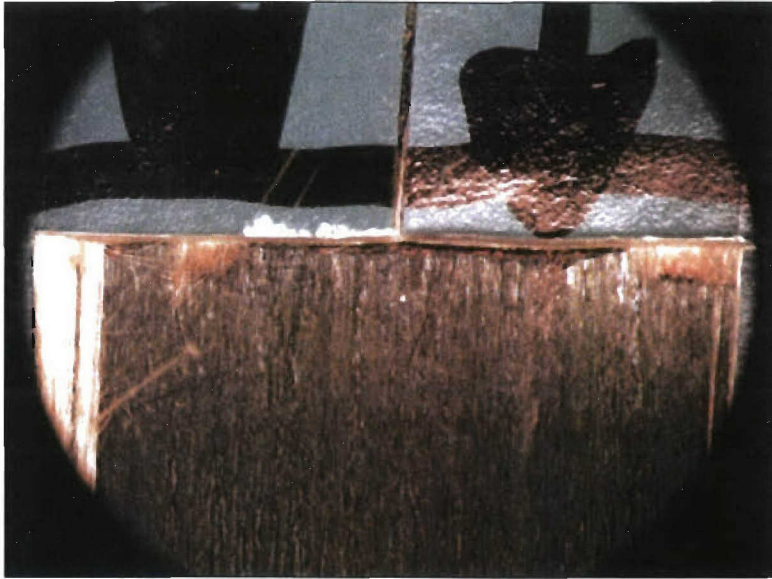

FIGURE Y-4. Close-up of Top Portion of Removed Section (6.5X Magnification).

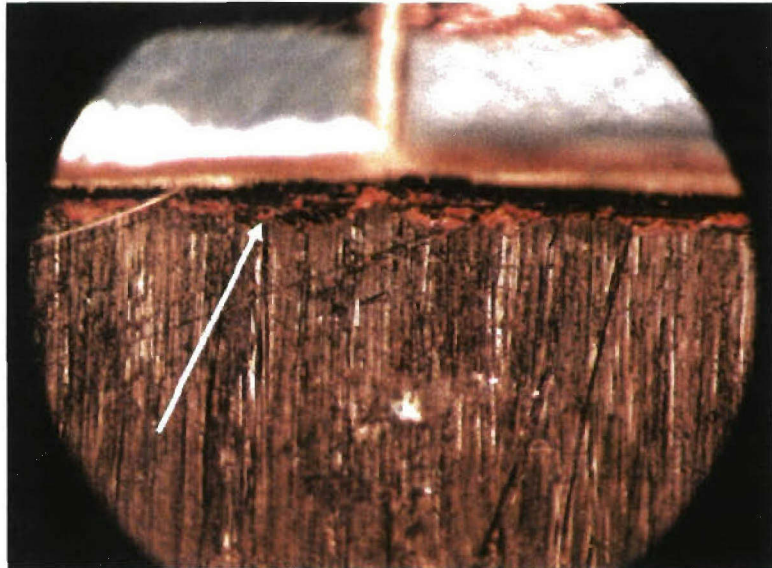

FIGURE Y-5. Close-up of Top Portion of Removed Section (26X Magnification).
(Note damage on carbon fiber surface from scoring overwrap layer.)

Inspection of the fracture surfaces of the two chips under 26X optical magnification reveals a broken, pebbled surface (Figures Y-6 and Y-7). The paint layer, resin layer, and Kevlar fibers can be seen. These layers are more easily distinguished on the cut surface of the right chip (Figure Y-8). The right chip was examined under high magnification under scanning electron microscopy (SEM). The fracture surface is shown at 150X and 600X magnification in Figures Y-9 and Y-10. The cut surface is shown at 150X and 600X magnification in Figures Y-11 and Y-12.

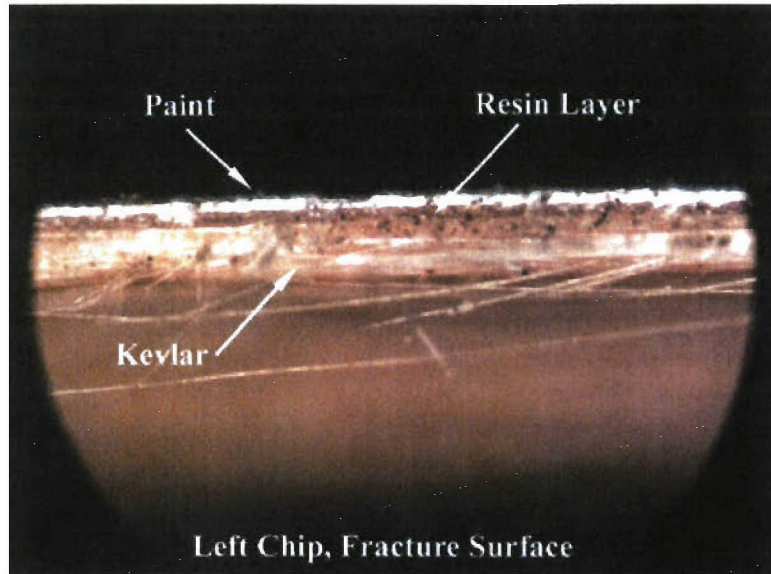

FIGURE Y-6. Fracture Surface of Left Chip (26X Magnification).

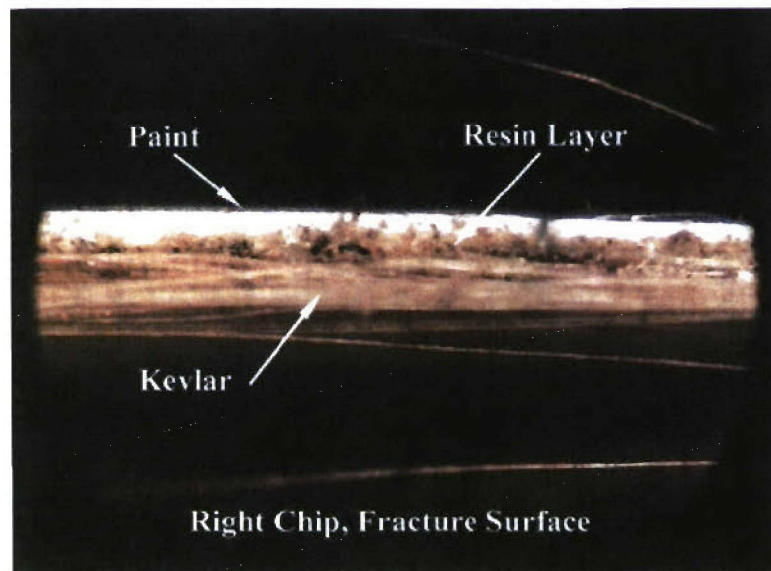

FIGURE Y-7. Fracture Surface of Right Chip (26X Magnification).

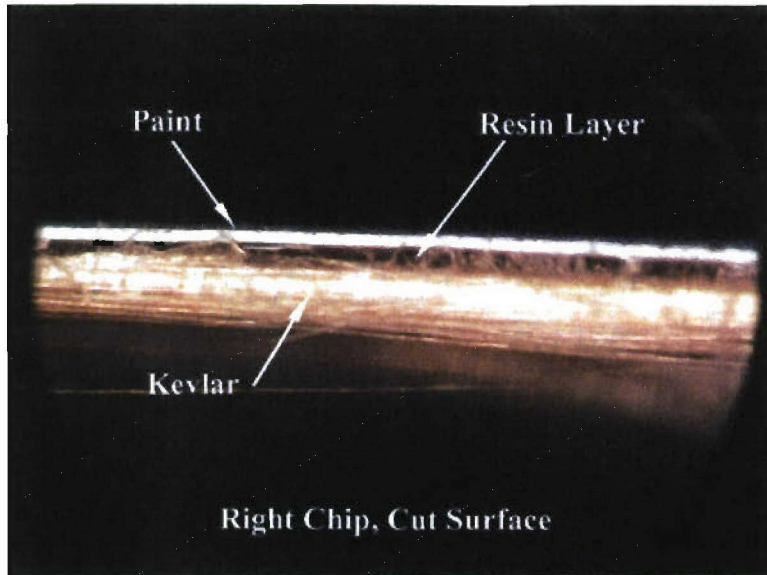

FIGURE Y-8. Cut Surface of Right Chip (26X Magnification).
(Note distinct paint and resin layers.)

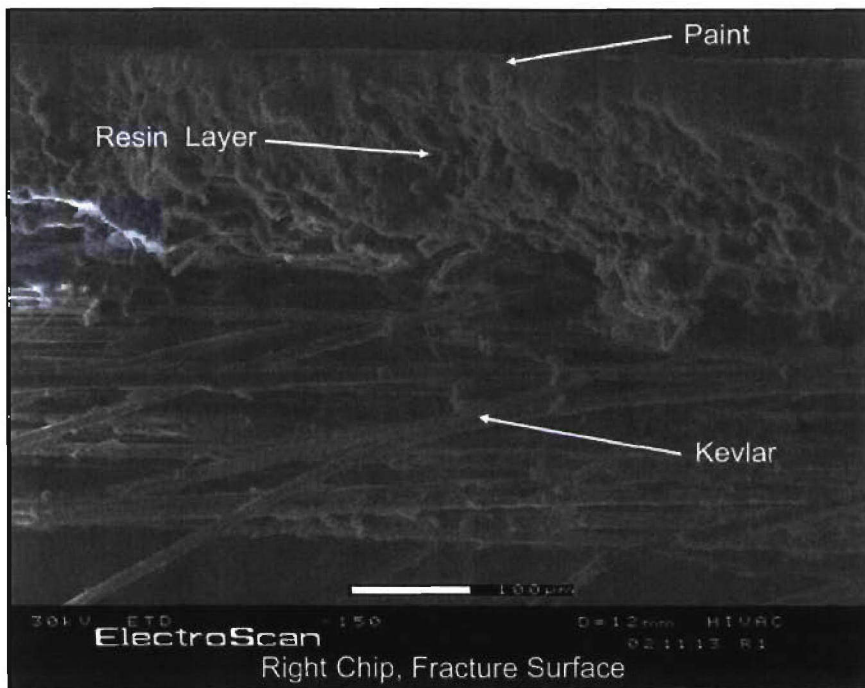

FIGURE Y-9. SEM Micrograph Showing Fracture
Surface of Right Chip (150X Magnification).

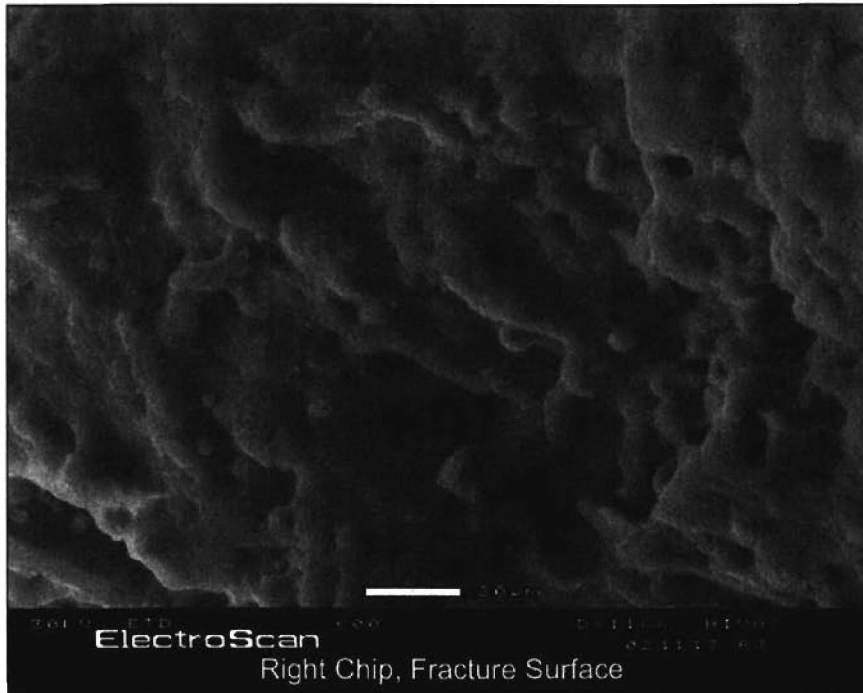

FIGURE Y-10. SEM Micrograph Showing Fracture Surface of Right Chip (600X Magnification).

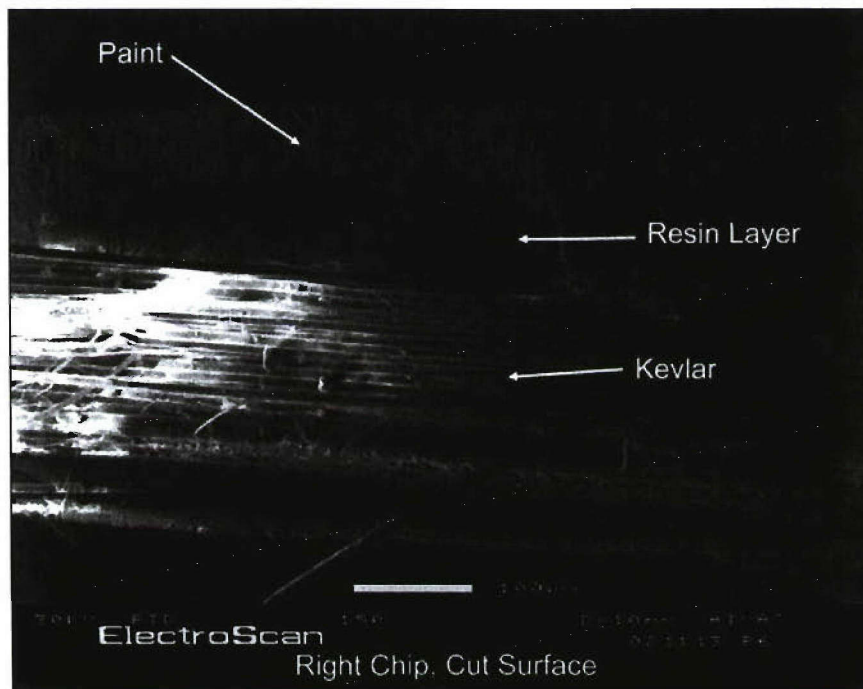

FIGURE Y-11. SEM Micrograph Showing Cut Surface of Right Chip (150X Magnification).

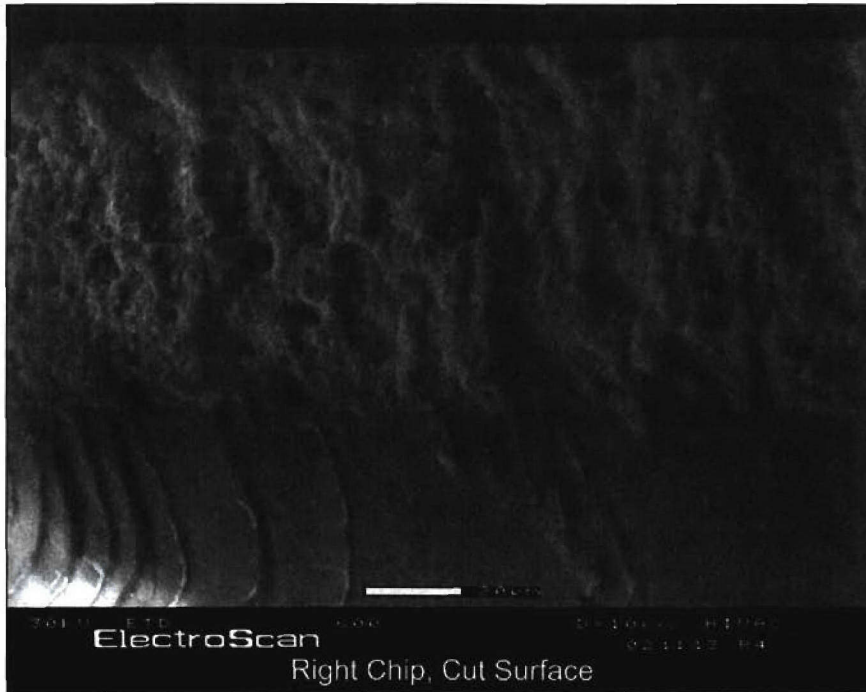

FIGURE Y-12. SEM Micrograph Showing Cut Surface of Right Chip (600X Magnification).

It was noted that the ends of the crack were separated by 0.40 inch, a distance that corresponds to the width of four tows of Kevlar. Each wrap of Kevlar consists of three tows approximately 0.1 inch wide. It is possible that the crack formed between tows. To help determine where the cracks were forming, a cross section of the right chip was metallographically mounted for inspection. High-magnification photographs were taken along the width of the sample by using an optical metallograph. These were combined to form a collage (Figure Y-13). It was hoped that clear indications could be found showing the separations between Kevlar tows. Two indications were found at approximately 0.10 inch and 0.20 inch from the fracture surface (Figures Y-14 and Y-15), but it is uncertain if these are separations of the tows or artifacts from the sample itself. No conclusion can be reached at this point as whether the cracks are forming between tows or within the tows.

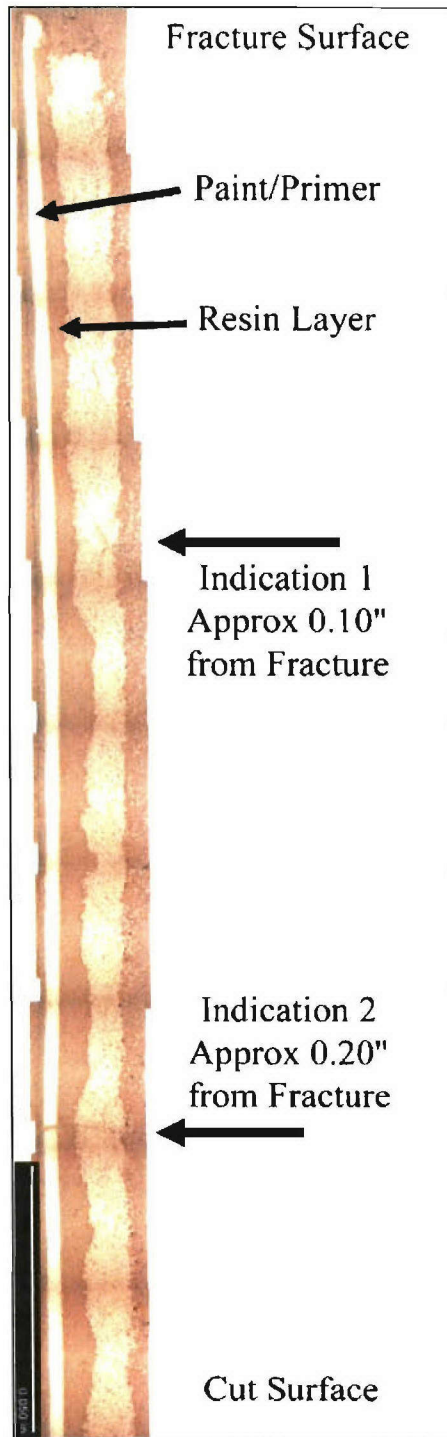

FIGURE Y-13. Collage Image Showing Cross Section of Right Chip. (Two indications of possible Kevlar tow separations are indicated. See Figures Y-14 and Y-15 for more detail.)

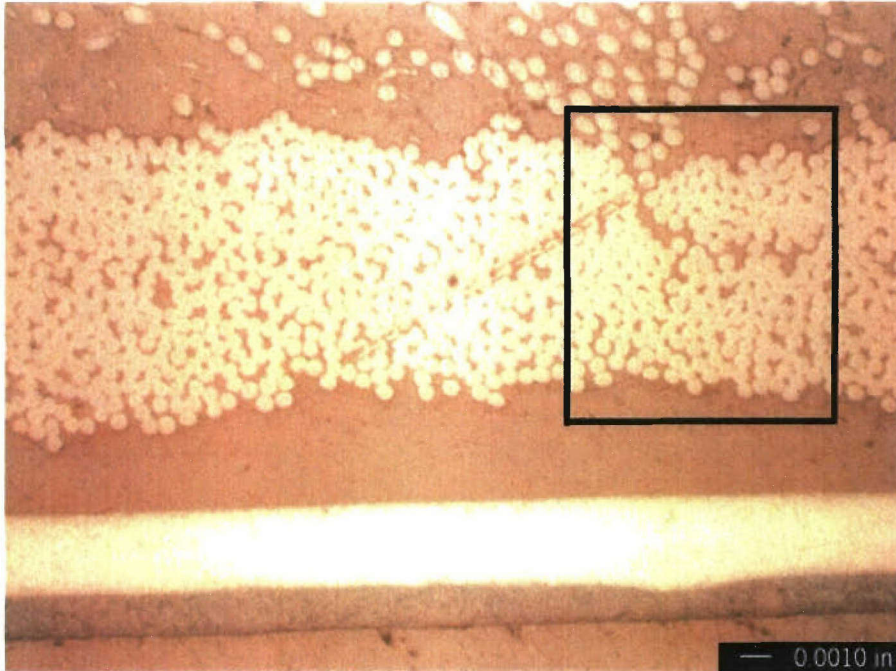

FIGURE Y-14. Indication 1 Showing Possible Separation of Kevlar Tows (200X Magnification).

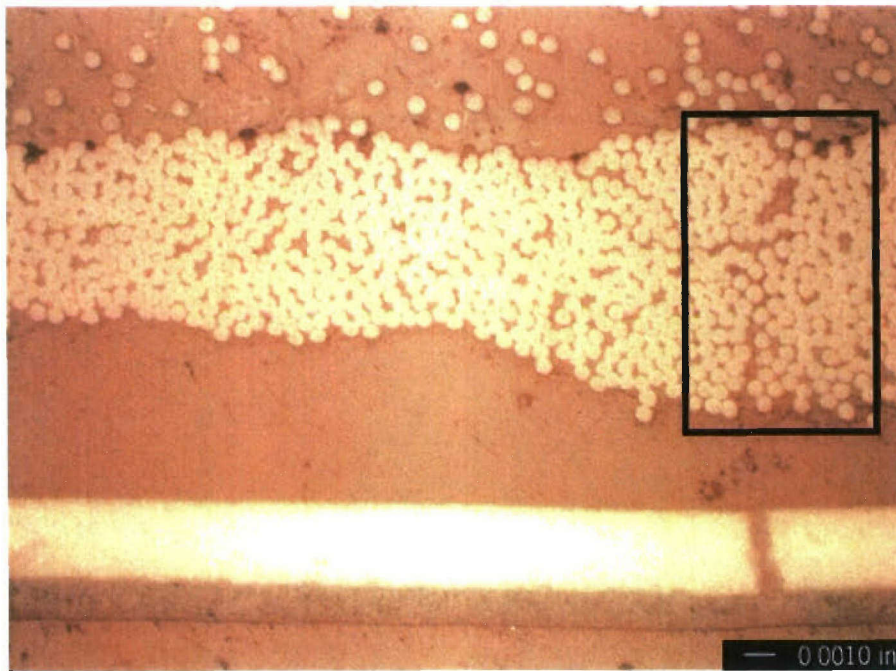

FIGURE Y-15. Indication 2 Showing Possible Separation of Kevlar Tows (200X Magnification).

INITIAL DISTRIBUTION

- 6 Naval Air Systems Command, Patuxent River
 - NAVAIR HQ Library (AIR-4.0C1) (2)
 - AIR-4.0P, Airworthiness Office (1)
 - AIR-4.0X (1)
 - AIR-4974, Steve Claus (1)
 - PMA-259 (1)
- 1 NOSSA, Navy Insensitive Munitions Office, Don Porada
- 2 Defense Technical Information Center, Fort Belvoir
- 1 Aerojet Corporation, Advanced Projects, Virginia Engineering, Gainesville, VA (Hugo Kruesi)
- 1 ATK Company, Rocket Center, WV (Mick O'Neal)
- 1 Chemical Propulsion Information Agency, Columbia, MD (Michael Fisher)
- 1 Raytheon Missile Systems Company, Tucson, AZ (Adam Lefcourt)

ON-SITE DISTRIBUTION

- 1 Code 400000D, Frank Markarian
- 1 Code 45T000D (Archive copy)
- 3 Code 470000D
 - Randall Cope (1)
 - Antonella Thompson (2)
- 1 Code 47J000D, Roy Hageman
- 1 Code 47J140D, Martin Minthorn
- 1 Code 47J320D, Robert Pyke
- 1 Code 47J240D, Brian Veit
- 3 Code 47T000D, Stuart Blashill
- 1 Code 474000D, Vicki Brady
- 1 Code 477000D, Timothy Mahoney
- 1 Code 475000D, Kenneth Hayes
- 1 Code 476000D, Mark Lambert
- 1 Code 476200D, Peter Hudson
- 4 Code 477300D
 - Terry Roberts (1)
 - Steven Towne (1)
 - Daniel Miller (1)
 - Chris Sebastian (1)
- 1 Code 478300D, Terrence Munsinger
- 1 Code 497000D, Marc Pepi
- 3 Code 498000D
 - Larry Merwin (1)
 - Geoffrey Lindsay (1)
 - Brandy Flotten (1)
- 3 Code 498100D
 - Pamela Overfelt (1)
 - Merle Elson (1)
 - Alan Van Nevel (1)
- 1 Code 498200D, Jennifer Irvin
- 1 Code 498210D, Steve Fallis
- 1 Code 498230D, Mike Seltzer
- 1 Code 498400D, Wayne Tanaka