

Automatic Pipe Flushing Rig for Shipboard Piping Systems

U.S. DEPARTMENT OF TRANSPORTATION
Maritime Administration and the U.S. Navy

in cooperation with

National Steel and Shipbuilding Company
San Diego, California

Report Documentation Page

Form Approved
OMB No. 0704-0188

Public reporting burden for the collection of information is estimated to average 1 hour per response, including the time for reviewing instructions, searching existing data sources, gathering and maintaining the data needed, and completing and reviewing the collection of information. Send comments regarding this burden estimate or any other aspect of this collection of information, including suggestions for reducing this burden, to Washington Headquarters Services, Directorate for Information Operations and Reports, 1215 Jefferson Davis Highway, Suite 1204, Arlington VA 22202-4302. Respondents should be aware that notwithstanding any other provision of law, no person shall be subject to a penalty for failing to comply with a collection of information if it does not display a currently valid OMB control number.

1. REPORT DATE AUG 1992		2. REPORT TYPE N/A		3. DATES COVERED -	
4. TITLE AND SUBTITLE Automatic Pipe Flushing Rig for Shipboard Piping Systems				5a. CONTRACT NUMBER	
				5b. GRANT NUMBER	
				5c. PROGRAM ELEMENT NUMBER	
6. AUTHOR(S)				5d. PROJECT NUMBER	
				5e. TASK NUMBER	
				5f. WORK UNIT NUMBER	
7. PERFORMING ORGANIZATION NAME(S) AND ADDRESS(ES) Naval Surface Warfare Center CD Code 2230-Design Integration Tools Bldg 192, Room 128 9500 MacArthur Blvd, Bethesda, MD 20817-5700				8. PERFORMING ORGANIZATION REPORT NUMBER	
9. SPONSORING/MONITORING AGENCY NAME(S) AND ADDRESS(ES)				10. SPONSOR/MONITOR'S ACRONYM(S)	
				11. SPONSOR/MONITOR'S REPORT NUMBER(S)	
12. DISTRIBUTION/AVAILABILITY STATEMENT Approved for public release, distribution unlimited					
13. SUPPLEMENTARY NOTES					
14. ABSTRACT					
15. SUBJECT TERMS					
16. SECURITY CLASSIFICATION OF:			17. LIMITATION OF ABSTRACT SAR	18. NUMBER OF PAGES 139	19a. NAME OF RESPONSIBLE PERSON
a. REPORT unclassified	b. ABSTRACT unclassified	c. THIS PAGE unclassified			

DISCLAIMER

These reports were prepared as an account of government-sponsored work. Neither the United States, nor the Maritime Administration, nor any person acting on behalf of the Maritime Administration, (A) makes any warranty or representation, expressed or implied, with respect to the accuracy, completeness or usefulness of the information contained in this report/manual, or that the use of any information, apparatus, method, or process disclosed in this report may not infringe privately owned rights; or (B) assumes any liabilities with respect to the use of or for damages resulting from the use of any information, apparatus, method, or process disclosed in the report. As used in the above, "Persons acting on behalf of the Maritime Administration" includes any employee, contractor, or subcontractor to the contractor of the Maritime Administration to the extent that such employee, contractor, or subcontractor to the contractor prepares, handles, or distributes, or provides access to any information pursuant to his employment or contract or subcontract to the contractor with the Maritime Administration. ANY POSSIBLE IMPLIED WARRANTIES OF MERCHANTABILITY AND/OR FITNESS FOR PURPOSE ARE SPECIFICALLY DISCLAIMED.

FINAL REPORT
AUTOMATIC PIPE FLUSHING RIG
FOR
SHIPBOARD PIPING SYSTEMS
SP-1-83-6
TO
SNAME/SHIP PRODUCTION COMMITTEE
PANEL SP-1
FACILITIES AND ENVIRONMENTAL EFFECTS

BY
NATIONAL STEEL AND SHIPBUILDING COMPANY
SAN DIEGO, CALIFORNIA

CONTENTS

FOREWORD	1
INTRODUCTION	2
CONCEPT	3
PARAMETERS	4
PRODUCTION FLUSH	5
RECOMMENDATIONS	5
ADDENDUM	6
PROJECT CONCLUSIONS	6

APPENDIX

- A. AUTO FLUSH RIG OPERATION DISCUSSION
- B. HYDE PRODUCTS, INC REPORT
- C. BEELCO COMPUTER PROGRAM DESCRIPTION
- C. BEELCO COMPUTER SET POINT SELECTION
- D. FLUSH DOCUMENTATION
 - FOX STEERING GEAR
 - PFIEFER LUBE OIL PIPING

SP-1-83-6
Automatic Pipe Flush Rig
For
Shipboard Piping System Flushing

FOREWORD

Piping systems flushing is a most common task in any new construction or ship repair. The work is time consuming and labor intensive as well as schedule-impacting. In the absence of the possibility of deleting the process completely, this Project was devised to 1) Decrease the labor content for the task, and 2) Shorten the time cycle for completing and verifying the flush certification.

Additionally, the project was designed to have universal application throughout American shipyards. The merits of this type of NSRP Project, while remaining unglamorous and lacking super technology, are never-the-less at the heart of the intention to improve productivity.

The project does utilize current small computer application and high quality filtration techniques to accomplish the objectives. Therefore, the effort is certainly within current technology.

The original efforts of Mr. Ed Southern of Todd LA, the continual participation of Mr. Bill Nell and Hyde Products throughout, and the work of Mr. Gary Hobson of NASSCO were vital to the effort. Many THANK YOU's go to all who contributed.

INTRODUCTION

This project had its origin in a Todd Shipyard of Los Angeles study of PIPE SYSTEM FLUSHING, SP-1-83-10. The data derived from the study indicated that the labor content and schedule cycle time to complete the work were significant. If an automated flushing method for shipboard systems were developed and successfully tested some real productivity increase would be accomplished.

The concept for this study and project had been proposed and approved in the 1983 program but was contingent upon the results of SP-1-83-10.

In the fall of 1986, Hyde Products of Cleveland, Ohio entered the project to develop a rig that would control, monitor, and report a system flush. This work was done. However, a period of uncertainty for the project ensued when Todd closed the LA operation.

National ,Steel and Shipbuilding CO of San Diego, CA took responsibility for the completion of the project in November, 1989. This work focused on the Testing of the automated rig in a shipboard system flush and the completion of the project including the final reports and publication. A contract was made with Hyde to continue their participation and a schedule and plans were developed for an actual production flush at NASSCO.

What had been scheduled as the final oral report to the SP-1 group was made at the October, 1990 meeting at Groton, CT. Due to the test results, the positive findings, and unanimous agreement of the participants, it was recommended to the Panel that modifications and additional testing be undertaken. Therefore the final report was issued as an interim report with the addendum work to follow. The final published report contains the results and conclusions of the extended project work.

CONCEPT

In March of 1986, Project SP-1-83-10 PIPE SYSTEMS FLUSHING STUDY, was completed by Todd LA. One of the key recommendations in the final report was the design, building, and shipboard testing of an automated flushing rig.

The benefits to be derived from this project would be:

1. Reduction in the cycle time to perform a flush and verify the criteria data for a clean system.
2. Reduction of man hours needed to perform a flush.
3. Utilize current technology by providing computerized controls, read-outs, and print-outs to accomplish the above.
4. Universal application to American shipyards in general.

The normal operation of an on-board system flush has historically required long time cycles in which laboratory data would be provided (often more than once, even several times) before a system met the "clean criteria" of the specifications. This of course impacted scheduling of work since it was not possible to proceed with tearing down the flush set-up to make way for sequenced work to which the flush was prerequisite.

Many man hours have historically been required to set-up the piping for the flush along with the pump, filtering and metering devices required. The work also required more manning than what would be justified for the flush operation alone, to deal with system leaks and potential leaks.

By utilizing the technology of the small computer, was it possible to reduce both causes of inefficiency, and increase productivity and lower direct cost? If a control system could monitor the measured parameters of the flush and accurately measure "cleanness", the flush would only be as long as absolutely needed and the certification would be predictable with in a very narrow window of error.

It has always been the objective of NSRP to provide projects with application to industry wide benefit. Regrettably, this could not always be the case due to the diverse nature of shipyards and the related work. Therefore, it appeared to be an added potential return, that this project had the solid possibility of universal application.

PARAMETERS

A word about the specific parameters used in the experimental system is in order. First, very divergent flushing requirements exist in shipbuilding and repair; and second, various setups of pumps, pipe sizes, and other equipment are required depending on the system to be flushed. Therefore, the project, for both these reasons and limited economics, had to be somewhat selective as to the sizes and capacities used. Arguably, these are secondary to the primary objective of the project, which was the testing of an automated flushing concept.

The original Parameters were set forth as:

- * PUMP . . . Gear Type, 100 psi, 150 gpm.
- * PUMP MOTOR. . . 230 VAC, 15 HP.
- * SENSOR . . . System Pressure.
- * FILTERS . . . Duplex. Silt Control, 180 DEG F, 100 psi.
- * FLOW METER
- * CONTAMINATION SENSOR
- * RESERVOIR . . . 30 Gallons.
- * HEATER . . . Electric.
- * THERMOMETER
- * CONTROLLER . . . Computer with Readout Printer.

The System would operate as follows:

- * Manually set the parameters: PRESSURE, TEMPERATURE RANGE, and FLOW RATE.
- * start the Flush.
- * switch to AUTOMATED/COMPUTER CONTROL.
- * System to Shut Down on LIMITATION CONTROL: PRESSURE, TEMPERATURE, PARTICLE COUNT.
- * Computer Readout Furnishes the Basis for FLUSH COMPLETION.

These initial parameters and operating procedures were basically sound but proved to be inadequate when put to the actual operating test. This is covered in the Addendum which deals with the extended test.

HYDE PRODUCTS

Hyde Products of Cleveland, Ohio, who are very active in the industry, were engaged to design and build the test rig. Todd contacted them initially April 1, 1986. A contract was initiated Sept. 4, 1986. Delivery was made in February 1987.

The Hyde Design consisted of:

- * GEARED PUMP . . . 150 gpm, 150 psi.
- * VARIABLE SPEED DRIVE.
- * LIQUID BAG FILTER MODULE.
- * RESERVOIR . . . 30 Gallons with Heater.
- * COMPUTER . . . Beelco (Programmable).
- * SIGNAL PROCESSOR. . . Micro-pure MPS-D.

PRODUCTION FLUSH

The production flush was performed at NASSCO on a Repair contract ship. The following were key factors:

- *SHIP/SYSTEM:USS FOX(CG-33)/Hydraulic Steering Systems, Port & Starboard.
- *work performed by G.Hobson, NASSCO Repair Department and J.Fife, Hyde Products. .RIG shakedown, adjustments, and flush..August 13-17, 1990.
- *US Navy acceptance of PCP (Process Control Procedure) and Test Results utilizing the Project Flushing Rig was obtained without problem.
- *Flush Cycle Time was 1 HR 45 MIN.

CONCLUSIONS/RECOMMENDATIONS

The following were the recommendations as summarized by NASSCO and Hyde Products:

- 1) Change the primary computer control to flow rate.
- 2) Utilize pressure, temperature, and particle count as secondary controls.
- 3) Provide coalescing filters to filter off condensates.
- 4) Tie the heater control to the computer: the flushing media temperature and system pressure are in a relatively unstable condition until a constant operating temperature can be maintained.
- 5) Hood or house the computer in order to make the LED readout easier to view in ambient light conditions.
- 6) Eliminate the air bubbles in the media: these are confused as particles in the particle counter.
- 7) Examine the emergency shutdown methodology: the quickest stoppage is most desirable . . .pressure drop, temperature rise/drop, etc. should be utilized.
- 8) Future design should include hard mounting of the computer and 480v, 3 phase as the basic electrical power.

The project appeared to have the possibility of fully meeting all the original objectives:

- * Decrease Labor Costs
- * Shorten Task Cycle
- * Utilize Computer Technology
- * Universal Application

The recommendation was made to the Panel that as many of the above 8 items be incorporated into the test rig, and that an additional test be performed by NASSCO. This was accepted and the necessary work commenced.

ADDENDUM

Following approval to proceed with the work as outlined in the report to the panel meeting at Groton, CT in October '90, the modifications and re-test were undertaken. This work was completed on March 20, 1992 with the successful production flush of the Matson PFIEFER lube oil piping at NASSCO.

The following is a summary of up to date comments concerning the recommendations (refer to Page 5) made following the first test:

- 1) The computer was changed to flow rate as the primary control. This worked quite well.
- 2) Using pressure, temperature, and particle count as secondary controls also worked well.
- 3) The cost associated with adding coalescing filters was not within the resources. This item has been incorporated in the Phase II project proposed for '93.
- 4) The heater control was tied to the computer and functionally tested. However, a heating system was not required in the actual PFIEFER on board flush.
- 5) The LED read-out was hooded to make it easier to read. The ultimate solution to the variations in ambient working light is related to hardware and systems design.
- 6) Elimination of the air bubbles in the media proved to be a situation beyond the scope of the project resources and has been incorporated in the Phase II project proposal.
- 7) The Emergency Shutdown methods appear to be adequate by employing the control parameters of the system: Pressure and flowrate controls.
- 8) The need for appropriate electrical power provisions must be a primary design parameter. Future systems should have primary voltage of 480 v., 3-, which can be stepped down.

PROJECT CONCLUSIONS AND DISCUSSION

The use of the automated flush rig in the 2 project tests produced indications that the desired objectives can be attained and that production design for automated rig function and control should be pursued.

- 1) The labor used in a flush can be reduced 40% to 90% depending upon current yard practice, contract specifications, and various other conditions.
- 2) The flush duration can be reduced 30% to 50% or possibly more.
- 3) Direct computer reporting of the "cleanness" data can be developed. This was not fully accomplished in this "test" rig which was limited to the counting of a "set" micron size rather than a range of counts

for a range of micron sizes. A set of software routines must be developed.

- 4) The possibility that all yards might want to pursue this technology remains a question for the individual yard, however, there are no extraordinary economic barriers. A system comparable to the test rig would cost \$25,000. to \$35,000.

The main limitations to the "test" rig, as previously stated, were that a wide range of system piping sizes, media, and other criteria were not feasible. This was a true "concept model" with various compromises. These are:

- 1) It has a physical configuration that is not modular. It can be used only on small diameter pipe systems at 150 GPM flow rate.
- 2) The computer system is 5 year old vintage.
- 3) It is not applicable to retrofit and universal use. A production design would use state of the art computer hardware and software, be totally modular, and possess retrofit capability for existing systems.

A study was made as a post-project evaluation in order to add emphasis to the various conclusions. The work was conducted in conjunction with the NASSCO Machinery Department, which did the actual testing of the rig on both the FOX and the PFIEFER. The details of the study are contained in the Appendix.

The experience with the project tests was applied to an LST diesel engine flush with which the department is very familiar. The graph on the next page shows the expected results if the automated technology and methodology were used in place of the current practice.

FLUSH ACTIVITY	REDUCTION
Test(MN HRS)	91.7%
Flush All Phases(MN HRS)	95.8%
Setup/Tear Down(MN HRS)	50.0%
Duration(DAYS)	35.7%

It can be seen that the impact on costs and schedule will be well worth this effort, even at 50% of these possibilities.

DIESEL ENGINE FLUSH COMPARISON

LST'S - MAN HOURS SPENT
A THREE STAGE FLUSH

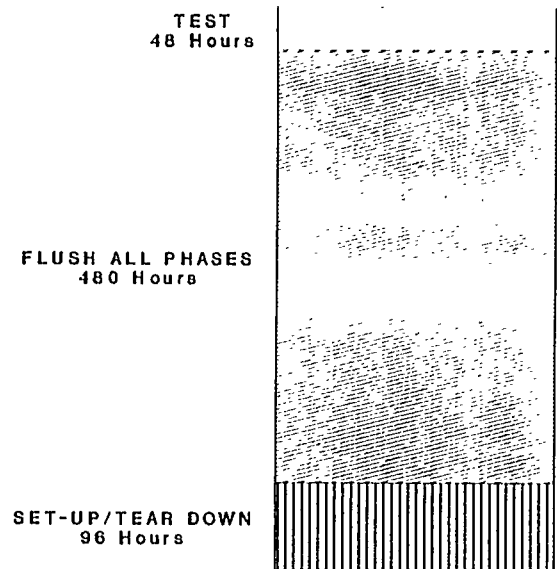

CURRENT METHOD
624 HOURS 14 DAYS

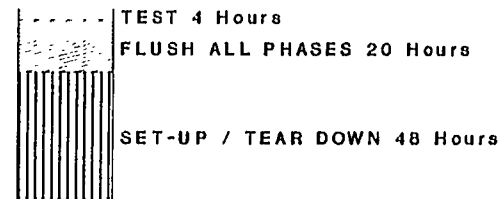

AUTO FLUSH RIG
72 HOURS 9 DAYS

NASSCO - AMEGA ENG. INC
NSRP 1-83-6

APPENDIX A.

AUTO FLUSH OPERATION DISCUSSION

Auto Flush Operation Discussions

Scope: To explain the tasks involved with the operation of the Auto Flush Rig.

Tasks

1. Set-up / Tear Down:

The times would depend on what type of system was being flushed. There are one, two, and three stage flushes. An example would be: a steam turbine and reduction gear (Main Engine) require a two stage flush; bypassing the bearings and heat exchanger on the first stage, then flushing the system as a whole including the heat exchanger and bearings, after it was ascertained that the first stage was clean. Another example are the diesel engines on the LST's, these require a three stage flush.

A.	Flush System Build-up	<u>Duration</u>	<u>Man</u>	<u>Hours</u>
*	Small Flush:	1 Day	4	Hours
*	Normal Flush:	1 Day	24	Hours
*	Reduction Gear:	1 Day	36	Hours
*	Diesel Engine:	1 Day	24	Hours
B.	Tear Down			
*	Small Flush:	1 Day	4	Hours
*	Normal Flush:	1 Day	16	Hours
*	Reduction Gear:	1 Day	36	Hours
*	Diesel Engine:	1 Day	24	Hours
C.	Size Variance Factor - The larger the flush the more the work content. Below is a range of typical pipe sizing by flush type.			
*	Small Flush:	1/2"	to	1 1/4" pipe
*	Normal Flush:	1 1/2"	to	3" pipe
*	Reduction Gear:	4"	to	8" pipe
*	Diesel Engine:	4"	to	10" pipe

D. Proximity to Auto Flush Unit Factor

* Close to unit: no change in times.

* Farther away from unit: requires more hose to hook up and more time to look for leaks away from the immediate operating area.

E. Other "Check Points"

The more check points you have on a flush the longer it takes to flush. We lose approximately eight hours on a check point(paper work, lost time, quality insurance time, etc.).

2. Doing the Flush / Re Flush

.4. Flush Elements(Tasks)

1. Diagram the flush.
2. Write a proposal on how we will flush the unit.
3. Make up the flange pieces.
4. Hook up the equipment for the start of the flush.
5. Flush till Clean.
6. Inspect and sell flush or phase of flush.
7. Go on to the next phase.

B. Equipment Needed

1. Pump
2. Heater (steam or electric)
3. Filter (cartridge or bag)
4. Hoses and Connections
5. Cleaning medium (water, oil, etc.)
6. Particle counter
7. Monitors for: Flow rate, temperature, pressure, etc. .

C. Filter Types:

1. Cartridge 1 to 25 micron
2. Bag Filter Nylon
3. Bag Filter Muslin
4. Bag Filter Polyester Felt

The automated flush rig utilized a polyester felt filter bag. This was found to be far superior and cost effective than the cartridge and other filter bag material that had been utilized in our non-automated flushes.

D. Staffing

1. Old conventional pumps and filters required two people around the clock.
 - a. Small Flush: 1 Day to 2 Days
 - b. Normal Flush: 2 Days to 7 Days
 - c. Reduction Gear: 7 Days to 10 Days
 - d. Diesel Engines: 4 Days to 10 Days
2. With the automated flushing rig it takes one person two hours per day, once the flush is started. This is due to the computer control of the flush rig.
 - a. Small Flush: 2 to 4 Hours
 - b. Normal Flush: 4 to 14 Hours
 - c. Reduction Gear: 14 to 20 Hours
 - d. Diesel Engine: 8 to 14 Hours

E. Testing (Particle Count)

1. Particle Count in four to five sizes.
 - o - 5 micron
 - 5 - 10 micron
 - 10 - 25 micron
 - 25 - 50 micron

50 - 100 micron

2. Water Content

3. Acidity

F. Verification of Test

1. Lab report with data for the above listed categories.

2. Submitted paper work with all check points.

This summary is provided by: Gary Hobson, Assistant Superintendent, Machinery Department, NASSCO.

AE GH 5-5-92

APPENDIX B .

HYDE PRODUCTS, INC REPORT

Final Project Report
Automatic Pipe Flush Rig for
Shipboard Piping Systems
SP-1-83-6

By:
Hyde Products, Inc.
June 6, 1992

1.0 INTRODUCTION

On September 4, 1986, Hyde Products, Inc. was contracted by Todd Pacific Shipyards Corporation to construct a prototype automated flush rig. The rig was to be used in Phase 2 of Project SP-1-83-10. The completed rig was delivered to Todd for testing. The testing was not completed at Todd due to the closing of the Yard. It was eventually returned to Hyde and used for flushing the LHD Anchor Windlass piping.

In November of 1989, National Steel and Shipbuilding contracted with Hyde for the rental of the flushrig. NASSCO was to complete the project originally begun by Todd.

1.2 CONTRACT REQUIREMENTS

The flush rig was to be designed to be operated in both computer automated and manual modes.

A standard Micro Pure MPS-D was chosen for contamination monitoring and a Beelco programmable controller for control.

The main components to be incorporated in the system were:

Pump module	Gear pump 150 GPM at 150 psi.
Motor Controller	230 or 450 Volt A/C 10 to 15 HP.
Variable speed drive	10 to 15 HP 230 or 450 Volt
Filter module	Liquid bag filter.
Reservoir module	Rectangular tank with a minimum capacity of 30 gallons with immersion heater.
Control computer	IBM personal computer PC
Signal Processor	Micro Pure MPS 3000

The assembled rig was bolted to a 4x8 foot drip pan with a 6 inch lip and skids, such that the pan doubles as a pallet for transporting the rig.

2.0 TESTING

2.1 SHOP TEST

The flush rig was assembled and demonstrated at Hyde's shop in Cleveland, Ohio in December of 1989. A simulated pipe flush was setup and the system was operated. Mr. Gary Hobson from NASSCO was present for the demonstration.

During the demonstration, it was noted that setting the system operating parameters on the computer was very difficult. It was determined that the computer should be modified to include a digital readout of the settings and the operating conditions. The computer was returned to Beelco to be modified.

2.2 OPERATIONAL TEST

An operational test was conducted at National Steel & Shipbuilding, San Diego, from August 13 to August 17. Mr. James Fife, from Hyde Products, traveled to San Diego to assist in the set-up and operation of the flushrig. The system to be flushed was the hydraulic steering piping aboard the USS FOX- CG-33.

The operating parameters for the test were as follows:

1. Minimum flow rate: 62 GPM
2. Operating temperature: 130-140 Deg. F.

The fluid was initially clean enough to put the system into the clean flush cycle for one hour. The entire flush was run for approximately 1 hour and 45 minutes.

3.0 GENERAL OBSERVATIONS

The computer program controls the flush rig motor speed according to system pressure, not flow rate. An operating pressure of 110 psi was used at the start of the operational test. Because the computer would try to maintain the set pressure as the fluid temperature increased, a higher pressure corresponding to a flow of 85 gm was chosen. This allowed for changes in flow as the computer maintained the pressure setting. The system still shut down if the flow was below 62 GPM.

It was noted during the test that the motor speed became erratic. This appeared to be due to the increased temperature of the fluid. The system finally shutdown, due to high temperature, at about 141 Deg. F. The step unit that controls how quickly the computer adjusts the motor speed was increased. This appeared to correct the erratic motor speed.

4.0 CONCLUSION

The test resulted in both positive and negative conclusions. It must be understood that the purpose of this project was twofold: First, to show that by automating the flushing process, the number of hours required to complete a system flush could be reduced thus reducing labor cost and the number of samples required to be taken and lab tested. Second, to evaluate which controls, equipment, and system design was most suitable. Following are our conclusions regarding the advantages of the flush rig in its present form and the improvements required.

4.1 SYSTEM ADVANTAGES

- 4.1.1 The extended time required to conduct a system flush can be reduced. Knowing when the system is clean by monitoring the particle counter greatly reduced the length of the flush.
- 4.1.2 The number of samples required during the flush is reduced. A sample at the beginning of the flush provides a starting reference. Additional samples are not required until the particle counter indicates that the contamination is below the acceptable level.
- 4.1.3 Only a minimal of operator supervision is required after the rig is started.
- 4.1.4 A printout of fluid conditions is provided by the computer control.

4.2 SUGGESTED IMPROVEMENTS

- 4.2.1 The physical size of the unit is, perhaps, too large to be placed below deck close to the equipment being flushed.
- 4.2.2 The particle counter readout cannot be translated to the 'contamination parameters required by the Navy.
- 4.2.3 The computer control logic should be revised to allow control of the system by flow, not pressure.
- 4.2.4 The system set up should be changed to make it easier to change the set points.
- 4.2.5 The LED readouts should be changed as they are not readable outdoors.

Some of the advantages listed above may not have been evident during the test. This system, as with any prototype, has shortcomings and requires additional engineering. The final system design needs more input from individuals familiar with flushing procedures. This input was not available when the existing rig was built.

APPENDIX C.
BEELCO COMPUTER

AMEGA ENGINEERING INC
13788 Nogales DR
Del Mar, CA 92104

SP-1-83-6
AUTOMATIC FLUSHING RIG
BEELCO COMPUTERIZED CONTROL

Program Description (Revised Unit per Project Extension)

This unit is programmed to perform the following functions:

1. Control the SYSTEM FLOW RATE by controlling pump drive speed by comparing the System Flow with a Preset Flow S.P.3 and reducing the Control Signal proportionally with timed steps S.P.4.
On Startup the Output Signal is 0 and will Ramp Up until the Flow matches S.P.3.
On Shutdown the Output will reset to 0.
2. Shutdown the pump when Pressure exceeds the System MAX Pressure S.P.6. Red Printout, "SHUTDOWN By HIGH SYSTEM PRESSURE".
3. Shutdown the pump when the Filter Inlet Pressure exceeds the Preset Pressure S.P.5. Red Printout, "SHUTDOWN By HIGH FILTER PRESSURE".
4. Shutdown the pump when System Flow is below a Preset Flow. The computer is programmed for a factor of 80 GPM, which means a Shutdown at S.P.3 minus 80. Red Printout, "SHUTDOWN BY LOW SYSTEM FLOW".

This Shutdown is bypassed for 30 seconds when the System is being started.
5. Shutdown the pump when Temperature exceeds System Temperature S.P.7 plus 20 DEG. Red Printout, "SHUTDOWN BY HIGH SYSTEM TEMPERATURE".
6. Shutdown the pump and Reservoir Heater when Reservoir Level Switch is open. Red Printout, "SHUTDOWN BY LOW RESERVOIR LEVEL".
7. Shutdown the pump when System Pressure is below 30 PSIG. Red Printout, "SHUTDOWN By LOW SYSTEM PRESSURE".

This Shutdown is bypassed for 30 seconds when the System is being started.

NOTE: Prior to Shutdown the current Operating Conditions are printed.

8. Prints out the Fluid Conditions at preset time intervals S.P.10 and Monitors the Contamination Count S.P.8. When the Contamination Count drops below the S.P.8 value, the Condition Printout occurs every 1/12 of the Preset Time Interval S.P.10 (in minutes only). Also, at this point, The Clean Flush Timer is activated and counts down from the value Preset in S.P.9. When this timer reaches 0 the Conditions printout, the Pump Shuts down, and "DONE" is printed in Red. However, if the Contamination Level rises above the S.P.8 setting, the Clean Flush Counter is set to the s.P.9 value and the process continues.
9. The Reservoir Fluid Temperature is read with a R.T.D. probe. When the temperature is below S.P.7, a solid state relay is energized to drive a heater relay, however, the relay will not energize if the reservoir level is so low as to open the Level Switch.

THE AUTOMATIC STARTUP occurs when Auto Start is activated and the Reservoir Temperature reaches the S.P.7 value. The Heater is turned off and the Pump is started. The Auto Start is activated by selecting "Activate Auto Start" and pressing the "Push To Set" button. Deactivation is made by selecting "Deactivate Auto Start" and pressing the "Push To Set" button.
10. When "Paper Advance" is selected and the set button pressed the printer will advance one line.
11. When "Fluid Condition" is selected and the set button pressed the printer will print the Fluid Conditions.
12. When "Print Set Points" is selected and the set button pressed the printer will print the Values for all Current S.P. Selections.
13. When "Timer Reset, Start" is selected and the set button pressed the Timer is reset to ZERO and the Shutdown Latch released. However, if a Shutdown Condition still exists, the printer will print that Condition, except for LOW FLOW and LOW PRESSURE which are bypassed for 30 seconds.

AMEGA ENGINEERING INC
13788 Nogales DR
Del Mar, CA 92104

SP-1-83-6
AUTOMATIC FLUSHING RIG
BEELCO COMPUTERIZED CONTROL

SET POINT Selection (Revised Unit per Project Extension)

The SET POINTS (S.P.) are selected as follows:

- STEP 1. Select the desired S.P. Number on the "Setpoint Select" switch or the Message on the Readout, the Message changes as the selector switch is advanced.
- STEP 2. Select the value desired with the "Setpoint Set %11 switch, read under NEW SP.
- STEP 3. Press the "Push To Set" selector button, read under SP.

S.P.# FUNCTION AND DESCRIPTION

-
- | | |
|---|-------------------------------------------------------------------------------------------------------------------------------------------------------------------------------------------------------------------------|
| 1 | OPERATING CONDITIONS 1 "PRESS.FLR(P) .FLOW.RES TE"

Readings for: System Pressure, Filter Pressure, Flow Rate GPM, and Reservoir Temperature. |
| 2 | OPERATING CONDITIONS 2 "TEMP.CONT.DA HR MI RUN TIME" (the SECONDS indicator toggles 0,1 when the pump is idle)

Readings for: Fluid Temperature (in piping), Contamination Value, Days/Hours/Minutes of Run Time. |
| 3 | FLOW RATE CONTROL (setting for MAX GPM)

Low GPM is S.P.3 Setting"minus 80 GPM |
| 4 | CONTROLLER RESPONSE TIME |
| 5 | FILTER (INLET) MAX PRESSURE |
| 6 | SYSTEM MAX PRESSURE |
| 7 | RESERVOIR (SYSTEM) TEMPERATURE |
| 8 | SYSTEM CONTAMINATION CONTROL |
| 9 | CLEAN FLUSH TIME (desired duration after S.P.8 is attained) |

APPENDIX D .
FLUSH DOCUMENTATION

Note: Due to the request of several panel members and others interested in the project, this documentation is included as an additional reference.

370-1360-90

NASSCO

NATIONAL STEEL AND SHIPBUILDING CO.

DATE: 7/27/90

PROCESS CONTROL PROCEDURE NO: 153-90

Flush Hydraulic System
TITLE

DISTRIBUTION		CONTRACT NO. NASSCO <u>EH-52</u>
SUPSHIPS (FOR APPROVAL)		SPECIFICATION NO. <u>NA</u>
NASSCO SHIP SUPT	<u>1</u>	SHIP: <u>FOX</u>
NASSCO SHIP INSPECTOR	<u>1</u>	ARTICLE OR ITEM NO. <u>561-11-001</u>
NASSCO SAFETY DEPARTMENT		MOD. NO. <u>NA</u>
CH. INSPECTOR REPAIR		I.D. OF PART: <u>Flush hydraulic system of port + starboard steering gear</u>
CH. INSPECTOR NDT		
T. EWERS-ESTIMATING REPAIR	<u>1</u>	
GEN. FOREMAN-REPAIR WELDING		
GEN. FOREMAN-REPAIR PIPING	<u>1</u>	
GEN. FOREMAN-SHIPFITTING		
GEN. FOREMAN - O.S. MACHINIST	<u>2</u>	

BASIC ARTICLE REQUIREMENT

Para 3.16.1 Accomplish the requirements of 209-09 of 2a

NOTE: This Process Control procedure has been previously approved under PCP No. _____
By: _____
on: _____

PREPARED BY: HOBSON
APPROVED BY: J. Helson
Chief Inspector, Repair Div.
NA
Safety Manager
REVIEWED BY: R.E. Little 7-27-90
SUPSHIP

THIS PCP IS A CHECK POINT NOTIFY QA 4 HOURS BEFORE STARTING.

CHECKPOINT

NASSCO

NATIONAL STEEL anti SHIPBUILDING COMPANY
Harbor DR and 28th Street
San Diego, CA 92138

Date: 4-18-90

PROCESS CONTROL PROCEDURE No. _____
Flush the Steering Gear Hydraulic System

_____ Title

Enclosures: (1) Drawing Starb Unit
(2) Drawing Port Unit
(3) Flow Rate Chart in GPM
(4) NAS 1638 Particle Count Acceptance Standards
(5) Test Call Out and Record Sheet
(6) Work Item 561-11-001

- 1.1.1. Submitted to the QA DEPT NASSCO.
- 1.1.2. PCP Title: Flushing the Steering Gear Hydraulic System.
PCP NO: _____ PCP Date: _____
Ship: USS FOX CG 33
Contract NO: H 819 Z Work Item: 561-11-001
Para(s) : 3.16 (3.16.1 thru 3.16.3.).
- 1.1.3. Description of Process: Paragraph 2.1.2.
- 1.1.4. Personal Qualifications Requirements: Joureyman.
- 1.1.5. Inspection Documentation Forms: Enclosed.
- 1.1.6. Acceptance/Rejection Criteria: MIL STD 419
(Para.5.6), RE: MIL-L-17672, NAS 1638 CLASS 10 oil.
- 1.1.7. Method of Ensuring Direct Knowledge: Shop Meeting.

- 1.1.3. Method CT Procedure Control: First Line supervisor will be in possession of this PCP at the job site.

Comments: This Flush will be performed utilizing a variable speed hydraulic pump driving the flush oil. THE system is equipped with digital monitoring devices, and a computer control. Flushing fluid will be oil conforming to MIL-17672.

- 2.1.1. This PCP was developed using: REF a. , Standard Item No. 009-09; REF b., O322-LP-037-1000. Steering Gear Electro-HYdraulic model SHRE-9.25A Manual; and REF f. .
MIL STD 419 c.

- 2.2. Process Description:

- 2.2.1. Objective : Clean the Steering Gear Hydraulic Piping to the acceptance level for CLASS 10 oil. This does not include the Emergency, Hand Steering Piping.
SEE Pfcfl. 3.2 FOR ACCEPTANCE

- 2.2.2 Equipment: Variable Speed Hydraulic Pump, 150 GPM, Electric Drive with Heater capacity to maintain a Flushing oil temperature Of 130-140 DEG F. Filter and Filter Bass, pressure Gauge, Temperature Gauge, and Flow Meter (planned flow rate minimum of 62 GPM). are built into the Flushing Rig.

- 2.2.3. Instrumentation: All instruments used to measure pressure, temperature, flow rate, and other essential elements of the flush will be calibrated to MIL-STD 45662.

- 2.2.4. Connecting Method: Flexible Hoses run from the Pump/ Flush Rig to the Steering System Piping.

- 2.2.5. Flushes will be performed in two (2) Phases: Port Piping, Starboard Piping.

- 2.2.6. Preparation: Hydraulic Cylinders will be "jumpered" OUT of the system.

- 2.2.7. Flush System Schematics: REF attached Enclosures (1)+(2)

- 2.2.8. Samples of flushing fluid will be taken from the sampling valve built into the Flushing Unit. This sampling valve is located on the inlet side of the flushing filter.

3.1. Safety Precautions:

- 3.1.1. Flushing oil at 130-140 DEGS Fahrenheit can cause serious burns. Extreme caution will be exercised at all times. Danager signs will be posted Prior to start of flush, and will remain posted throughout the flush.
- 3.1.2. Due to fire hazards, all hot work, welding, burning, grinding, and smoking will be secured in the space where the flush is being performed. NO HOT WORK and NO SMOKING signs will be posted at times during the flush.

3.2 Acceptance Standard

The fluid entering the temporary filter will meet the class 10 requirements of NAS 1638 for particulate contamination. Water content shall not exceed 0.05 percent for any single sample. The average of samples taken shall not exceed 0.03 for the system.

ENC-1

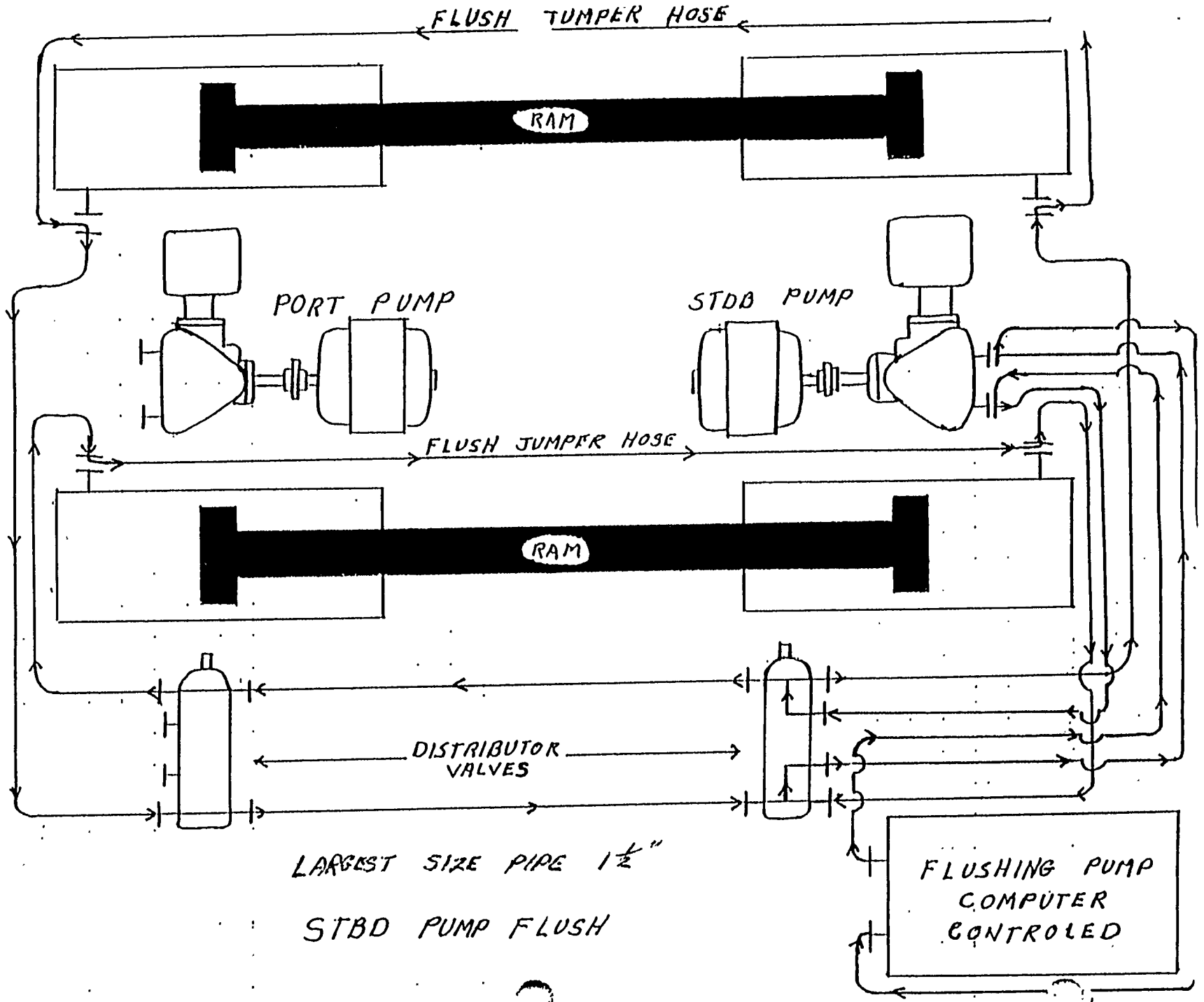

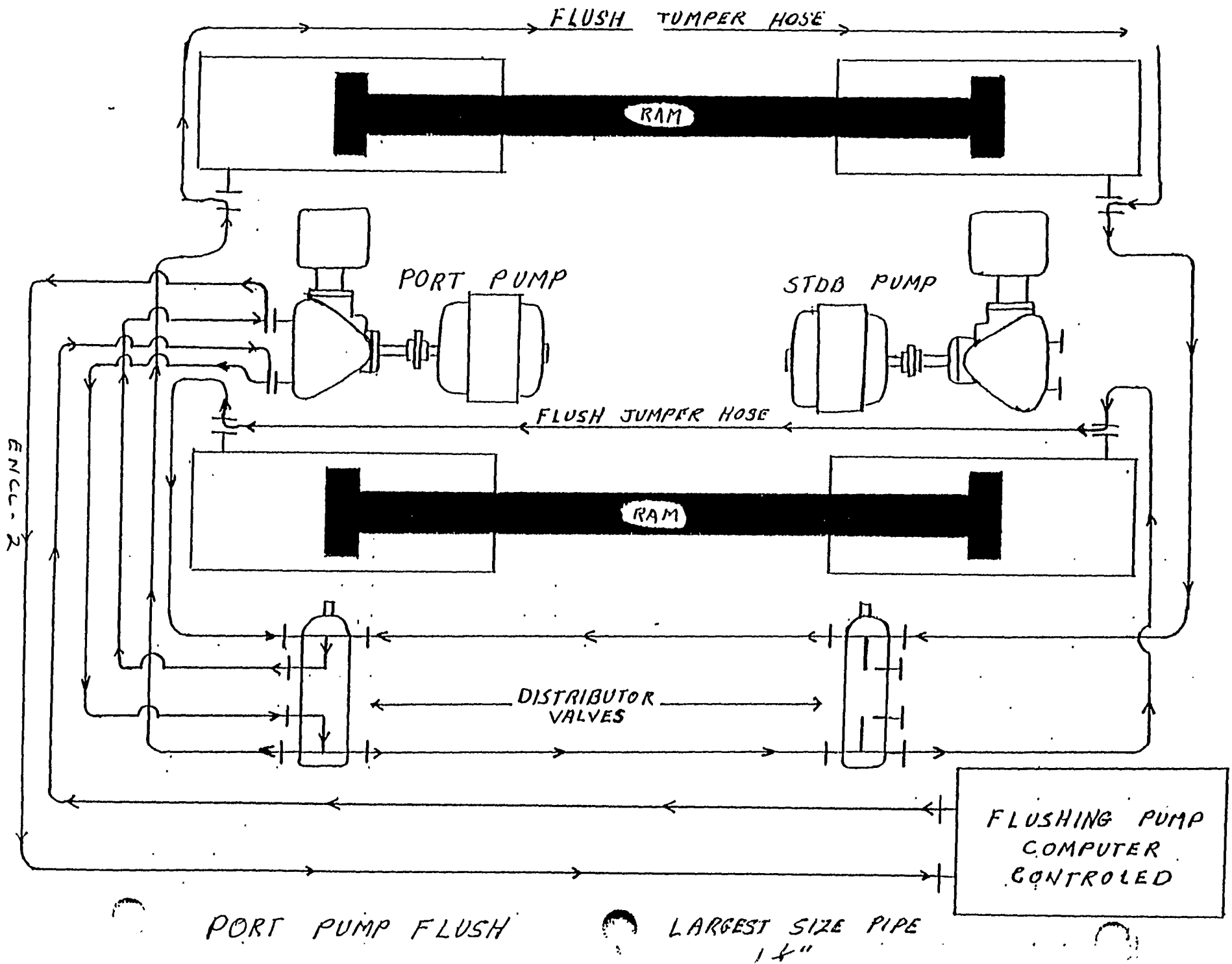

FLUID 2135

FLOW RATES IN GALLON PER MINUTE

PIPE I.D. INCHES	FLUSHING TEMPERATURE (DEG F)		
	100	120	140
.125	10.5	6.5	4.0
.250	21.0	13.0	8.0
.375	31.0	20.0	12.0
.500	42.0	25.0	16.0
.625	53.0	32.0	20.0
.750	63.0	39.0	25.0
.875	74.0	45.0	27.0
1.000	85.0	52.0	31.0
1.250	105.0	65.0	40.0
1.500	127.0	77.0	47.0
1.750	148.0	90.0	56.0
2.000	170.0	105.0	65.0
2.250	190.0	118.0	71.0
2.500	211.0	130.0	80.0
2.750	232.0	142.0	87.0
3.000	254.0	155.0	95.0
3.500	296.0	180.0	111.0
4.000	338.0	206.0	127.0
5.000	423.0	258.0	158.0
6.000	508.0	310.0	190.0
7.000	592.0	361.0	222.0
8.000	675.0	412.0	255.0
9.000	761.0	465.0	288.0
10.000	845.0	515.0	317.0

EWCL- (3)

TABLE VII
PARTICLE COUNT ACCEPTANCE STANDARDS
 Maximum Contamination Limits (Based on a 100 ML Sample Size)**

Particle Size Range (Micrometre)*	NAS 1638 Classes											
	1	2	3	4	5	6	7	8	9	10	11	12
5 to 15	500	1K	2K	4K	8K	16K	32K	64K	128K	256K	512K	1024K
15 to 25	89	178	356	712	1425	2850	5700	11.4K	22.8K	45.6K	91.2K	182.4K
25 to 50	16	32	63	126	253	506	1012	2025	4050	8100	16.2K	32.4K
50 to 100	3	6	11	22	45	90	180	360	720	1440	2880	5760
Over to 100	1	1	2	4	8	16	32	64	128	256	512	1024

* The term "MICROMETRE" replaces the term "MICRON". Both define a size of one millionth of meter.

** For NAS 1638 Classes 1 thru 9, fluid samples less than 100 ml are not allowed. For Classes 10 thru 12, samples smaller than 100 ml (but not less than 25 ml) are allowed, but the quantity of contaminants shall be expressed on the basis of 100 ml sampling. For example; the quantity of particles present in a 25 ml sample shall be multiplied by 4 and expressed in terms of 100 ml. The actual sample size (in this case, 25 ml) shall also be reported.

TABLE VIII
PARTICLE NET WEIGHT ACCEPTANCE STANDARDS
 Weight of Particles for 100ml based on Net Weight (APP 785)

NAS 1638 Class	100	101	102	103	104	105	106	107	108	109	110
Weight(mg)	.02	.05	0.10	0.30	0.50	0.70	1.0	2.0	4.0	8.0	16.0

Classes 100, 101, and 102 will require samples larger than 100 ml.

* Not defined in NAS 1638.

ENCL-(4)

.25

COAR:

PCN: 56111-A. 1

SURVEYOR: MURPHY

1. SCOPE:

- 1.1 Title: Steering Gear: repair and test
- 1.2 Location of Work: Steering Gear Room (2-211-o-E)
- 1.3 Identification:
 - 1.3.1 Qty (One) Steering Gear: Western Gear Corp., Mfr. ID SHRE9-25A. APL 600230013
 - 1.3.2 Qty (Two) Main Pump: Vickers AOM Div. Sperry Rand Corp. Mfr. ID PV2032. 9 Pistons, Type-Axial piston, 1760 RPM, Mfr. Dw\$ 824889. APL 019160309
 - 1.3.3 Qty (Two) Replenishing Pump: Vickers AOM Sperry Rand Corp.. Mfr ID V20081C12-5S8. 11.6 GPM. Type-RTY-Vane 12 Vanes, APL 019160319
 - 1.3.4 Qty (Two) Motor: Reliance Electric Co. , Mfr. Dwg 34926RevB. 60 HP. 440 VAC, 1760 RPM. APL 174751166
 - 1.3.5 Qty (Two) Controller: Cutler-Hammer Inc.. Mfr ID 6962ED681. Mfr Dwg 962-1-63M7. APL 151203022

2. REFERENCES:

- a. Standard Items
- b. 0322-LP-037-1000, Electro-Hydraulic Steering Gear Model SHRE-9.25A
- c. 0936-LP-003-7010 . Handbook of Cleaning Practices
- d. MIL-STD-271
- e. 0900-LP-003-8000 . Surface Inspection Acceptance Standards for. *Metals*
- f. Mil-STD-419, Cleaning and Protecting Piping, Tubing and fittings for Hydraulic Power *Transmission* Equipment
- g. 803-2145518, Spray Shields for Mechanical Joints

3. REQUIREMENTS:

- 3.1 Accomplish the requirements of 009-23 of 2.a.
- 3.2 Remove. repair and test the units of 1.3 in accordance with 3.3 through 3.21.3.
- 3.3 **Remove and dispose of oil** from the hydraulic steering system.

ENCL-(6)

CHANGE ONE

3.4 Disassemble the port and starboard hydraulic pumps, including the connected relief valves, power limiter, servo control, replenishing valves and replenishing pumps, using 2.b. for guidance.

3.4.1 Measure and record sizes and clearances, using 2.b. for guidance.

3.4.2 Clean each part free of foreign matter, using Chapter 4 and 5 of 2.c. for guidance.

3.4.3 Inspect each part for wear and defects, using 2.5. as guidance for accept or reject criteria.

3.4.3.1 Submit four legible copies of "a report listing results of the requirements of 3.4.1 and 3.4.3 to the SUPERVISOR.

3.4.4 Accomplish liquid penetrant tests on each pump cylinder barrel, valve plate, valve block and servo control housings in accordance with 2.d. The accept or reject criteria shall be in accordance with Class I, Section III, Tables II and III of 2.a.

3.4.4.1 Submit four legible copies of a report listing results of the requirements of 3.4.4 to the SUPERVISOR.

3.5 Repair the port and starboard hydraulic pumps, connected relief valves, power limiter, servo control, replenishing valves and replenishing pumps, using 2.b. for guidance.

3.5.1 Stone the pump shaft seal areas and journals and remove high spots.

3.5.-2 Lap and polish the cylinder barrels, valve plates and replenishing valves.

3.5.3 Restore mating surfaces-exposed-by disassembly removal. Repair by removing high spots, burrs, abrasions, and foreign matter, where removal can be accomplished by hand tools.

3.5.3.1 Chase and tap exposed- threaded areas.

3.6 Reassemble the hydraulic pumps, connected relief valves, power limiter, servo control, replenishing valves and replenishing pumps, using 2.b. for guidance.

3.6.1 Remove existing and install new the following parts:

Total Quantity Required	Name of Part	Piece No. on 2 .5.. Fig. 2-2-11	Part No.
2 AY	Sub-Assembly Piston	3	46156
4	Bearing	31	82374
2	Seal	42	171358
2	Bearing. Rear	46	127357
4	Bearing, Thrust	47	44002
2	Bearing, Front	48	133912
2	Ring. Thrust	49	133784
2	Bearing	52	43990
2	Spring	53	2948
2	Bearing	57	44006
2	Bearing, Cylinder	62	38571
2	Bearing	63	192314
2	Washer. Thrust Bearing	64	201396
2	Ring, Thrust Bearing	65	201397
2	Spring	67	200261
8	Seal	76	42310

Piece No.
on 2.b..
Fig. 1-7-6

4	Seal Washer	6	B22311
2	Sleeve	26	B22412
4	Seal. Oil	47	.50005-s
2	Spring	57	B101341
4	Seal . Salt Water	70	240005
2	Seal	87	50197-s

Piece No.
on 2.b..
Fig. 2-2-9

4	Spring	5	B-27661
4	Ball	6	

Piece No.
on 2.b.,
Fig. 2-2-10

2	Ball	3	A-101008
2	Spring	12	A-331004
2	Spring	15	A-331003
2	Seat, Valve	14	A-441004

3.6.1.1 Remove existing and install new gaskets, bolts, screws, studs, nuts, pins, keys, rings and washers. The material shall conform with the specifications on Material List of 2.b., Figures 2-2-11, 1-7-5, 2-2-9 and 2-2-10.

CHECK POINT (Clearances)

3.6.2 Measure and record final sizes and clearances, using 2.5. for guidance.

3.6.2.1 Submit: four legible copies of a report listing results of the requirements of 3.6.2 to the SUPERVISOR.

3.7 Accomplish the requirements of 009-17 of 2.a. for the equipment listed in 1.3.4. using 2.b. Chapter 3 for guidance.

3.7.1 Straighten each shaft to within 0.001 inch total indicator reading.

3.3 Accomplish the requirements of 009-36 of 2.a. for each controller listed in 1.3.5. using 2.b., Chapter 3 for guidance.

3.8.1 Submit four legible copies of a list of new parts installed in place of those found to be missing and defective with documenting invoices or other substantiating data to the SUPERVISOR. Total cost of new Parts, **excluding parts specifically identified to be replaced**, shall not exceed 450 dollars without prior approval of the SUPERVISOR. Total cost of new parts not specifically identified to be replaced, greater or less than above dollar amount, will be the subject of an equitable adjustment.

5.9 Disassemble the port and starboard steering ram packing glands, using 2.b., Figure 1-7-4 for guidance.

3.9.1 Measure and record sizes and clearances, using 2.b., Figure 1-7-4 for guidance.

3.9.2 Clean each part free of foreign matter, using Chapter 4 and 5 of 2.C. for guidance.

3.1C Repair the port and starboard rams, using 2.b. for guidance.

3.10.1 Hone each ram in way of packing gland to remove glazing, scoring, and ridging.

3.11 Reassemble the port and starboard ram packing glands, using 2.b., Figure 1-7-4 for guidance.

3.11.: Remove existing and install new the following parts:

Total Quantity Required	Name of part	Piece No. on 2.b., Fig. 1-7-4	Mfr. Part NO.
4	SE packing Assy.	13	N-100833FC13
4	Wiper Ring	17	N-100833PC17
8	Ram Soft Stop	20	c-101437

3.11.1.1 Remove existing and install now capscrews and washers. The material shall conform With the specifications on Material List of 2.b.. Figure 1-7-4.

3.12 Disassemble the helix screw assembly. using 2.b.. Figure 1-7-7 for guidance.

3.12.1 Measure and record sizes and clearances. using 2.b. , Figure 1-7-7 for guidance.

3.12.2 Clean each part free of foreign matter. using Chapter 4 and 5.of 2.b. for guidance.

3.13 Repair the helix screw assembly. using 2.b.. Figure 1-7-7 for guidance.

3.13.1 Stone the helix screw to remove high spots.

3.14 "Reassemble the helix screw assembly. using 2.b., Figure 1-7-7 for guidance.

3.15 Reinstall the port and starboard hydraulic pumps. including the connected relief valves, power limiter, servo control. replenishing valves and replenishing pumps. using 2.b. for guidance.

3.15.1 Remove existing and install new hold-down bolts and nuts conforming to-MIL-S-1222, Type III. Grado 5.

3.15.2 Align piping to each pump assembly, using 2.b. for guidance.

3.15.2.1 Remove existing and install now piping joint o-rings. capscrews and washers. Material shall conform to the specifications on the Material List of 2.b.. Figures 2-2-1 and 2-2-2.

CHECK POINT (Alignment)

3.15.2 Align and couple the motor to the pump in accordance with 2.b.

CHANGE ONE

3.15.2.1 Alignment shall be accomplished with piping installed. Piping shall be supported independently of the pump and shall not impose a strain on the pump

3.15.3 Remove existing and install new coupling fasteners and seals, using 2.b. for guidance.

CHECK POINT (Flush)

3.16 Clean and flush the steering gear hydraulic system.

3.16.1 ACCOMPLISH THE REQUIREMENTS OF 009-09 OF 2.a. FOR FLUSHING THE HYDRAULIC SYSTEM. THE PROCEDURE SHALL CONTAIN BUT NOT LIMITED TO THE FOLLOWING:

3.16.1.1 FILL THE STEERING GEAR SYSTEM WITH NEW OIL CONFORMING TO MIL-L-17672.

3.16.1.2 INSTALL JUMPER AND FLUSHING BLOCKS TO ACHIEVE A CONTINUOUS FLUSH THROUGH THE SYSTEM IN ACCORDANCE WITH 2.f.

3.16.1.3 MAINTAIN A FLUSHING OIL TEMPERATURE OF 130 TO 140 DEGREES FAHRENHEIT THROUGHOUT THE FLUSHING PERIOD.

3.16.1.4 TAKE AND ANALYZE OIL SAMPLES IN ACCORDANCE WITH 2.f.

3.16.1.5 SUBMIT FOUR LEGIBLE COPIES OF A REPORT LISTING RESULTS OF THE REQUIREMENTS OF 3.16.1.4 TO THE SUPERVISOR.

3.16.2 RESTORE THE SYSTEM TO FORMAL OPERATING STATUS ON COMPLETION OF FLUSH:

3.16.2.1 DRAIN AND DISPOSE OF FLUSHING FLUID, USING 2.b. FOR GUIDANCE.

3.16.3 FILL THE HYDRAULIC SYSTEM TO THE FULL MARK WITH NEW OIL CONFORMING TO MIL-L-17672.

3.16.4 RECHARGE THE HYDRAULIC SYSTEM. USING 2.b. FOR GUIDANCE.

3.16.5 LUBRICATE THE STEERING GEAR IN ACCORDANCE WITH 2.B..FIGURE1-7-13.

3.16.6 REMOVE EXISTING AND INSTALL NEW HYDRAULIC SYSTEM FILTERS. MATERIAL SHALL CONFORM TO THE SPECIFICATIONS ON MATERIAL LIST OF 2.b.

3.17 Adjust and set steering system relief valves in accordance with 2.b.

3.18 Install now aluminized cloth spray shields on hydraulic oil piping and valve flanges and Components in accordance with 2.g.

3.19 Accomplish the requirements of 009-32 of 2.a. for new and disturbed surfaces.

3.20 The length of externally threaded fasteners shall be such that a minimum of two threads to a maximum of five threads shall protrude beyond the crown of the tightened nut.

CHECK POINT (Operational Test)

3.21 Accomplish an operational test on the steering gear system. using 2.b. for guidance.

3.21.1 Accomplish the requirements of Work Item 841-11-001. using 2.b. for guidance.

3.21.2 Synchronize, adjust and set all steering angle indicators.

3.21.3 Submit four legible copies of a report listing results of the requirements of 3.21 to the SUPERVISOR.

4. NOTES :

4.1 This is an LOE item.

5. GOVERNMENT FURNISHED MATERIAL (GEM)

5.1 None.

INSPECTION/DEFICIENCY REPORT

PRINTED ON: 11/05/90 10:00
SERIAL NO.: 378-06333
DRAFT DATE: 11/05/90

FROM: NATIONAL STEEL AND SHIPBUILDING COMPANY,
SAN DIEGO, CALIF

TO: SUPERVISOR OF SHIPBUILDING, CONVERSION AND REPAIR, USN
SAN DIEGO, CALIF

SHIP: 378 USS FOX (CG-33)

WORK ITEM TITLE: STEERING GEAR; REPAIR AND TEST

WORK ITEM NO: 561-11-001

WO-CG NO: 3328-461

JOB ORDER NO: EH52

SURVEYOR: WILLIAMSON

CONTRACT NO: N00024-85-H-8192

SPEC NO: 3319

REFERENCE: (A) PARA. 3.16.1.5 OF BASIC

ENCLOSURE: SEE PROBLEM STATEMENT FOR LIST OF ENCLOSURES

LOCATION OR SYSTEM:

AFTER STEERING (2-211-0-E)

PROBLEM OR CONDITION:

ENCLOSURE (1) NASSCO 26-1 OF 8-23, 8-24 & 9-4 AND CLARKSON LAB
REPORTS PC-2560, PC-2561, PC-2552, PC-2553 AND
PC-2554 (8 PAGES)

(3328-85245) THE CONTRACTOR HAS TAKEN SAMPLES AND HAD THEM
ANALYZED FOR THE LUBE OIL FLUSH, ALL SAMPLES ARE GOOD AS
RELEASED.

RECOMMENDED ACTION:

ACCEPT REQUIRED REPORT AND CONSIDER PARA. 3.16.1.4 AS COMPLETE.

FAILURE TO RESPOND BY 11/09/90 WILL RESULT IN SCHEDULE IMPACT

DRAFTER: HOBSON/BRAUER

PHONE: 8774

SIGNATURE SHIP MGR: *Brauer*

DATE: 11-5-90

SUPSHIP RESPONSE:

8
C

REPORT ACCEPTED.

SIGNATURE SUPSHIP REP: *T. Williamson*

DATE: 11-7-90

FINAL ACTION:

SIGNATURE OF APPROVING OFFICIAL: _____

DATE: _____

TITLE/CODE _____

23 17 0 130 5

0 5 15 0 11 5

LABORATORY REPORT

Telephone (619) 425-1993

Established 1928

CLARKSON LABORATORY AND SUPPLY INC.
 350 Trousdale Dr. Chula Vista, Ca. 92010
 ANALYTICAL AND CONSULTING CHEMISTS

Date: 08-30-90
 Purchase Order Number: NH160525
 Account Code : NAT

To: _____ *

NATIONAL STEEL & SHIPBUILDING CO.
 P. O. BOX 85278
 SAN DIEGO, CA 92138
 Mail stop #15
 Attention: Jim Fellerman

Laboratory Number: PC-2560

Customer Phone Number: 544-7748

Sample Designation: _____ *

One oil sample dated on 08-28-90, from USS FOX
 CG-33 3328-85 245, marked as STBD Unit 0700 132, #1.

ANALYSIS:

Number of Particles per 100ml.

Particle Size
 in Microns

Sample

NAS 1638 Class 6
 Specifications

5 - 15

2250

16 K

15 - 25

710

2850

25 - 50

139

5 0 6

50 - 100

14

90

over 100

14

16

Water by Karl Fisher
 ASTM D-1744

0.03 %

Notes: This sample meets class 6 NAS 1638.
 K - 1000



 Alma Patricia Ortega

APO/mv

LABORATORY REPORT

Established 1928

Telephone (619) 425-1993

CLARKSON LABORATORY AND SUPPLY INC.
 350 Trousdale Dr. Chula Vista, Ca. 92010
 ANALYTICAL AND CONSULTING CHEMISTS

Date: 08-30-90
 purchase Order Number: NH160525
 Account Code : NAT

To:

 NATIONAL STEEL & SHIPBUILDING CO.
 P. O. BOX 85278
 SAN DIEGO CA 92138
 Nail stop #15
 Attention: Jim Felleram

Laboratory Number: PC-2561

Customer Phone Number: 544-7748

Sample Designation: _____ *

One oil sample dted on 08-28-90, from USS FOX
 CG-33 3328-85 245, marked as STBD Unit 1100 138, #2.

ANALYSIS:	Number of Particles per 100ml. *	
particle Size in Microns	Sample	NAS 1638 Class 6 specifications
5 - 15	1814	16 K
15 - 25	282	2850
25 - 50	60	506
50 - 100	12	90
Over 100	14	16

Water by Karl Fisher 0.04 %
 ASIM4 D-1744

Notes: This sample neets class 6 NAS 1638.
 K = 1000



Alma Patricia Ortega

APO/mv

LABORATORY REPORT

Established **1928**

Telephone (619) 425-1993

CLARKSON LABORATORY AND SUPPLY INC.
350 Trousdale Dr. Chula Vista, Ca. 92010
ANALYTICAL AND CONSULTING CHEMISTS

Date: 08-17-90
Purchase Order Number: NHI60513
Account Cede : NAT

To: _____ *

NATIONAL STEEL & SHIPBUILDING CO.
P. O. BOX 85278.
SAN DIEGO CA 92138
Attention: Ingersoll Mail Stop 15
Jim Felleemen

Laboratory Number: PC-2553

Customer Phone Number: 544-7748

Sample Designation: _____ *

One oil sample received on 08-16-90, marked as #2, 30 minutes, dated on 8-15-90, Steering Gear USS FOX OG-33.

ANALYSIS: particle Size in Microns	Number of Particles per 100ml	
	Sample	NAS 1638 Class 6 Specifications
5 -15	12.3 K	16 K
15 -25	292	2850
25 -50	78	506
50 -100	14	90
over 100	10	16

Water by Karl Fisher 0.04 %
ASM D-1744

Notes: This sample meets class 6 NAS 1638.
K = 1000

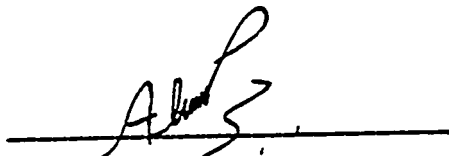
Alma Patricia Ortega

APO/mv

LABORATORY REPORT

Telephone (619) 425-3993

Established 1928

CLARKSON LABORATORY AND SUPPLY INC.
 350 Trousdale Dr. Chula Vista, Ca. 92010
 ANALYTICAL AND CONSULTING CHEMISTS

Date: 08-17-90
 Purchase Order Number: NH160513
 Account Code : **NAT**

To: _____ *

NATIONAL STEEL & SHIPBUILDING CO.
 P. O. Box 85278"
 SAN DIEGO, CA 92138
 Attention: Ingersoll Mail Stop 15
 Jim Fellermen

Laboratory Number: PC-2554 Customer Phone Number: 544-7748

Sample Designation: _____ *

One oil sample received on 08-16-90, marked as #3, Finish dated on 8-15-90, Steering Gear Uss OG-33.

ANALYSIS: Particle Size in Microns	Number of Particles per 100ml	
	Sample	NAS 1638 ClaSS 8 Specifications
5 -15	8.9 K	64 K
15-25	248	11.4 K
25-50	66	2025
50 -100	18	360
over 100	64	64

Water by Karl Fisher 0.03 %
 AS1M D-1744

Notes: This sample meets class 8 NAS 1638.
 K = 1000



 Alma Patricia Ortega

APO/mv

INSPECTION/DEFICIENCY REPORT

PRINTED ON: 01/26/90 09:16
SERIAL NO.: 378-2270
DRAFT DATE: 01/26/90

FROM: NATIONAL STEEL AND SHIPBUILDING COMPANY,
SAN DIEGO, CALIF

TO: SUPERVISOR OF SHIPBUILDING, CONVERSION AND REPAIR, USN
SAN DIEGO, CALIF

SHIP: 378 USS FOX (CG-33)

WORK ITEM TITLE: STEERING GEAR, REPAIR

WORK ITEM NO: 561-11-001
JOB ORDER NO: EH52
CONTRACT NO: N00024-85-H-8192
REFERENCE: (A) FARA. 3.16 OF THE BASIC
ENCLOSURE: NONE

WO-CG NO: 3328-461
SURVEYOR: WELCH
SPEC NO: 3319

LOCATION-OR-SYSTEM :
STEERING GEAR ROOM, 2-211-O-E

PROBLEM-OR-CONDITION :
(3328-85245) REF (A), WHILE REQUIRING A. 'CLEAN AND FLUSH' OF
THE STEERING GEAR HYDRAULIC SYSTEM, DOES NOT ADDRESS THE CLEANING
OF THE HYDRAULIC OIL STORAGE TANK. OPERATING NEWLY REPAIRED
EQUIPMENT WITH AN OIL SUPPLY SOURCE WHOSE CLEANLINESS IS UN-
SUBSTANTIATED IS NOT RECOMMENDED.

RECOMMENDED-ACTION :
SUPERVISOR INVESTIGATE AND ISSUE A CHANGE ORDER TO OPEN, CLEAN,
AND INSPECT THE OIL STORAGE TANK.

FAILURE TO RESPOND BY 02/03/90 WILL RESULT IN SCHEDULE IMPACT

D R A F T E R : C A N E L A / B R A U E R P H O N E : 8 7 7 4

SIGNATURE SHIP MGR: *[Signature]* DATE: --1-26-90

SUPSHIP- RESPONSE:

*SA NUMBER A00523 APPLIES WHEN
NEGOTIATED.*

2A

SIGNATURE SUPSHIP REP: *T. Williams* *[Signature]* DATE: 2-23-90

FINAL ACTION:

SIGNATURE OF APPROVING OFFICIAL: _____ DATE: _____
TITLE/CODE: _____

26 JAN 90 12:25

26 FEB 90 6:39

INSPECTION/DEFICIENCY REPORT

PRINTED ON: 01/18/90 07:59
SERIAL NO.: 378-02052
DRAFT DATE: 01/18/90

FROM: NATIONAL STEEL AND SHIPBUILDING COMPANY,
SAN DIEGO CALIF

TO: SUPERVISOR OF SHIPBUILDING, CONVERSION AND REPAIR, USN
SAN DIEGO, CALIF

SHIP: 378 USS FOX (CG-33)

WORK ITEM TITLE: STEERING GEAR; REPAIR AND TEST

WORK ITEM NO: 561-11-001
JOB ORDER NO: EH52
CONTRACT NO: N00024-85-H-8192
REFERENCE: (A) FARAS. 3.16.1.1 AND 3.16.3
ENCLOSURE: NONE

WO-CG NO: 3328-461
SURVEYOR: WILLIAMSON
SPEC NO: 3319

LOCATION-OR-SYSTEM :
STEERING GEAR ROOM 2-211-O-E

PROBLEM OR CONDITION:
(3328-85245) MIL-L-17672 IS SPECIFIED IN THE WORK ITEM.
CONTRACTOR RELIEVES THIS TO BE IN ERROR AND SHOULD BE
MIL-H-17672. WHICH COVERS THREE TYPES OF OIL.

RECOMMENDED ACTION:
SUPSHIP ADVISE/IDENTIFY CORRECT MIL-SPEC AND OIL TO BE USED.

FAILURE TO RESPOND BY 01/25/90 WILL RESULT IN SCHEDULE IMPACT

DRAFTER: YYK/BRAUER PHONE: 8774
SIGNATURE SHIP MGR: *Brauer* DATE: 1-18-90

(4) (A)

SUPSHIP RESPONSE:

MIL-H-17672 - 2135 HYDRBULIC OIL IS CORRECT.

SIGNATURE SUPSHIP REP: *T. Williamson* DATE: 1-23-90

FINAL ACTION:

SIGNATURE OF APPROVING OFFICIAL: _____ DATE: _____
TITLE/CODE: _____

0123 48

2 JAN 23 1990

REVISIONS

REV	ITEM	SH	DESCRIPTION	DATE	APPROVED
A	1	1	Added owner approval dates.		
	2	1	Changed total number of sheets to reflect addition of new enclosures.		
	3	3	Added Reference 1, List of Lubricants.		
	4	6	Revised General Note 2 per owner comment that flushing procedures include sections of piping cleaned prior to installation.		
	5	6	Revised General Note 3 per owner comment to include closing of system after flushing.		
	6	7	Added General Note 14 per owner comment to provide guidance on capacity of flushing pumps.		
	7	8, 18 23, 24 26	Added paragraph per owner comment that flushing oil is system oil and is to be removed from system after flushing.		
	8	12	Revised Paragraph 5.1.9 to include reference to new Enclosure 18.		
	9	12	Revised Paragraph 6.1.1 to include reference to new Enclosure 19.		

THIS DOCUMENT AND THE DATA DISCLOSED
HEREIN OR HEREWITH IS NOT TO BE REPRODUCED
USED, OR DISCLOSED IN WHOLE OR IN PART
TO ANYONE WITHOUT THE PERMISSION
OF NATIONAL STEEL AND SHIPBUILDING COMPANY

△¹

OWNER	7/6/90	7-25/90
U.S.C.G.	---	---
A.B.S.	---	---
SUBMITTED TO	SUBMIT DATE	APPROVAL DATE

DRAWING APPROVAL

CONTRACT NUMBER:

NASSCO NATIONAL STEEL
AND SHIPBUILDING COMPANY
SAN DIEGO, CA 92138

DRAWN	--	--
DESIGNED	C.A.M.	8/90
CHECKED	M. BROOKS	5/90
EXAMINED		

HAWAII CLASS CONTAINER SHIP

FLUSHING PROCEDURES

△²

APPROVED	DATE
<i>[Signature]</i>	7-10-90
APPROVED	DATE

SIZE	NASSCO DRAWING NUMBER	REV
A	445-342-7141	A
SCALE:	NONE	SHEET 1 OF 82

REVISIONS

REV	ITEM	SH	DESCRIPTION	DATE	APPROVED
A	10	14	Inserted new Paragraph 7.1.7 per owner comment to include flushing of all diesel generator lube oil sump lines and renumbered following paragraph.		
	11	18	Revised Paragraph 1.4 per owner comment to clarify inspections prior to filling lube oil sump.		
	12	19, 20, 20, 21, 22, 23	Changed temperature range from 105 - 115 F to 120 - 130 F per owner comment.		
	13	20	Revised Paragraph 2.4.8 per owner comment to clarify checking of cleanliness of lube oil cooler.		
	14	24, 28, 31	Revised Paragraph 1.1 per owner comment that flushing procedures include sections of piping cleaned prior to installation.		
	15	24	Revised Paragraph 4.1 to include reference to new Enclosure 20.		
	16	24	Corrected temperature range to read 160 - 170 F. Was 170 - 180 F.		
	17	28, 31, 34, 36	Added paragraph per owner comment to remove diesel flushing oil from system after completion of flushing.		
	18	35	Inserted new Paragraph 3.8 to flush piping for second diesel oil storage tank and renumbered following paragraph.		
	19	63, 64, 67, 68, 73	Added note for additional flushing paths per owner comment.		
	20	72	Added hose jumpers and dashed line to indicate additional flow paths per owner comment.		
	21	80	Added Enclosure 18 per owner comment to clarify flushing of lube oil transfer pump piping.		
	22	81	Added Enclosure 19 per owner comment to clarify flushing of lube oil purifier piping.		
	23	82	Added Enclosure 20 per owner comment to clarify flushing of clean oil return line.		

9/5/90 [Signature]

SIZE	NASSCO DRAWING NUMBER	REV
A	445-342-7141	A
SCALE: NONE		SHEET ²

REFERENCES A³

REF NO	NUMBER	TITLE
1	445-333-1326	List of Lubricants
2		
3		
4		
5		
6		
7		
8		
9		
10		

SIZE	NASSCO DRAWING NUMBER	REV
A	445-342-7141	A
SCALE: NONE		SHEET 3

TABLE OF CONTENTS

<u>NASSCO DRAWING</u>	<u>SYSTEM</u>	<u>SHEET</u>
	GENERAL NOTES	6
<u>SECTION I</u>	<u>LUBE OIL:</u>	
445-342-7105	LUBE OIL FILL, TRANSFER AND PURIFICATION	8
445-342-7106	LUBE OIL SERVICE	18
445-342-7134	CAMSHAFT LUBE OIL	23
445-342-7135	MAIN ENGINE LUBE OIL STUFFING BOX, AIR COOLER, AND SCAVENGING AIR DRAIN	24
445-342-7129	STERN TUBE LUBE OIL	26
<u>SECTION II</u>	<u>FUEL OIL AND DIESEL OIL:</u>	
445-342-7114	FUEL OIL AND DIESEL OIL FILL AND TRANSFER	28
445-342-7115	FUEL OIL AND DIESEL OIL PURIFICATION AND SERVICE	31
445-342-7136	AUXILIARY BOILER FUEL OIL AND DIESEL OIL SERVICE	34
445-342-7137	EMERGENCY DIESEL GENERATOR SERVICES	36
<u>SECTION III</u>	<u>STEAM AND CONDENSATE:</u>	
445-342-7113	AUXILIARY STEAM	37
445-342-7127	SERVICE STEAM	37
445-342-7130	FUEL OIL AND LUBE OIL TANK HEATING	37
445-342-7120	AUXILIARY BOILER AND WASTE HEAT BOILER CIRCULATING	38
445-342-7123	CONDENSATE, FRESH WATER, AND CONTAMINATED DRAINS	39
445-342-7121	AUXILIARY BOILER BLOWDOWN AND ESCAPE STEAM	40
<u>SECTION IV</u>	<u>SEA WATER:</u>	
445-342-7102	FIREMAIN	42
445-342-7109	SEA WATER COOLING	43
445-342-7116	BALLAST AND HEELING	44



SIZE	NASSCO DRAWING NUMBER	REV
A	445-342-7141	A
SCALE:	NONE	SHEET 4

TABLE OF CONTENTS
(CONTINUED)

<u>NASSCO DRAWING</u>	<u>SYSTEM</u>	<u>SHEET</u>
<u>SECTION V</u>		
	<u>FRESH WATER:</u>	
445-342-7107	LOW TEMPERATURE FRESH WATER COOLING	45
445-342-7108	HIGH TEMPERATURE FRESH WATER COOLING	46
445-342-7126	DISTILLING PLANT SERVICES	48
445-331-7503	POTABLE WATER	49
<u>SECTION VI</u>		
	<u>COMPRESSED AIR:</u>	
445-342-7118	SHIPS SERVICE AIR	50
445-342-7112	STARTING AIR	52
445-342-7119	CONTROL AIR	54
<u>SECTION VII</u>		
	<u>HYDRAULIC:</u>	
445-342-7128	HYDRAULIC PIPING	55
<u>SECTION VII</u>		
	<u>MISCELLANEOUS SYSTEMS:</u>	
445-342-7101	DECK DRAINS	57
445-342-7103	C0 ²	58
445-342-7110	BILGE	61
445-342-7117	DIESEL ENGINES AND AUXILIARY	
	BOILER EXHAUST	
445-342-7122	VENTS, SOUNDS, AND OVERFLOWS	62

SIZE~	NASSCO DRAWING NUMBER	REV
A	445-342-7141	A
SCALE : NONE		SHEET

GENERAL NOTES

1. Piping systems will be cleaned, flushed, and maintained to the extent necessary to ensure satisfactory operation of the system and components in service.
-  2. Piping sections fabricated in the shop may be flushed in the shop prior to shipboard installation. Sections of piping, such as gage lines or dead legs, may be cleaned by hand in the shop or onboard ship. Sections of piping satisfactorily cleaned in the shop or by hand will be included in system flushing as provided for in the flushing procedures. Individual cleaning of piping sections such as gage lines and dead legs is acceptable if they use mechanical joints.
-  3. Maintain cleanliness of piping and components by sealing openings when joints and fittings are disconnected for flushing pump, temporary strainer, spool piece, or jumper installation. After completion of flushing, piping systems and tanks should be closed as soon as practicable to prevent entry of foreign matter.
4. Any temporary fittings such as jumpers, blanks, and spool pieces must be cleaned, flushed, and degreased prior to installation.
5. Prior to flushing, units having in line mechanisms capable of trapping or affected by carry over of foreign matter will either be removed or blanked off and bypassed. These items will be inspected for cleanliness prior to a system startup. This applies primarily to pipe spuds on tanks or other system components not used and dead legs.
6. Refer to system diagrams when conducting the flushing procedures for installation of jumpers, spool pieces, flushing pumps, and strainers. Valve line ups will be conducted using the system diagrams.
7. Check for system leakage when filling system and when temporary or installed pumps are operated.
8. Vibration of systems during flushing will be required on specific systems as noted in the flushing procedure. Other systems may be vibrated as necessary.

SIZE	NASSCO DRAWING NUMBER	REV
A 1	445-342-7141	A
SCALE: NONE		SHEET 6

9. Air for piping blowdown will be dry and oil-free.
10. Tanks and sumps are required to be open for some flushing paths. Where these procedures indicate hose jumpers are used to bypass tanks or sumps, as an alternative the tank or sump may be used in the flow path. Conversely, where the tank is used in the flushing path, it may be bypassed using hose jumpers.
11. Temporary or installed strainers or filters should be closely monitored and cleaned when gages indicate strainer or filter is clogged. Most large particles of rust and foreign matter will be collected in the first few hours of flushing. It may be necessary to clean strainers or filters and change installed muslin bags every 15 minutes.
12. These procedures provide methods to flush the entire system or major sections of the systems. The systems may be flushed in smaller segments using the procedures for the entire system or major section.
13. Temporary strainers used for flushing shall be capable of having muslin bags installed. Temporary strainers shall also have magnets installed.
-  14. Temporary flushing pumps must be of sufficient capacity to develop line velocities which will transport debris, etc. from the system.

SIZE	NASSCO DRAWING NUMBER	REV
A	445-342-7141	A
SCALE	NONE	SHEET 7

LUBE OIL FILL, TRANSFER, CYLINDER OIL
AND DIBSEL GENERAL CRAINKCASE VENT SYSTEM
 445-342-7105

1.0 **General:**

1.1 A clean lubricating oil system is essential in order to safeguard the equipmenand assure proper operation.

The pipes, filters, valves, etc., must be free of metal chips, rust, weld beads, scale, dirt, etc. Before filling the system with lube oil the lube oil sump storage renovating, cylinder oil and cylinder oil day tanks must be cleaned by hand to remove any residues left over after the installation work. Corrosion products and corrosion preventative compound that are revealed will be removed manually insofar as practicable, by means of wire brushes. Interior surfaces of the lube oil sump, stowage, renovating, cylinder oil and cylinder oil day tanks will be wiped clean of corrosion preventative compound and other impurities by lintless cloth soaked in cleaning oil. At the completion of the inspection and manual cleaning, all inspection and cleanout covers that were temporarily removed will be reinstalled.

1.2 Installed or temporary ventilation will be in operation during flushing.

1.3 Whenever any inspection cover, tank cover, piping or other part is open for any length of time, the opening will be covered to prevent the entry of foreign matter.



1.4 System oil is to be used for the flushing oil. System oils are listed in Reference 1. Upon satisfactory completion of flushing the flushing oil is to be removed from the system.

2.0 Vent Piping for Main Engine Lube Oil Storage Tank and Lube Oil Renovating Tank:

2.1 Main engine lube oil storage tank.

2.1.1 Open storage tank, install blank flange at overflow check valve and install air hose at vent opening. Remove vent screen as necessary to increase air velocity.

2.1.2 Flush vent piping by blowing out with air at approximately 50 psig air supply .

SIZE	NASSCO DRAWING NUMBER	REV
A	445-342-7141	A
SCALE:	NONE	SHEET 8

- 2.1.3 During blowout, periodically vibrate the system piping with vibrators, wooden mallets or other equivalent means.
- 2.1.4 Continue blowout until discharge into tank is visually free of foreign matter.
- 2.1.5 After completion of blowout, remove air hose. Reconnect piping as necessary.

- 2.2 Lube Oil Renovating Tank:
 - 2.2.1 Blow-out vent piping as described in paragraph 2.1.

- 2.3 Lube Oil Purifier Sludge Tanks:
 - 2.3.1 Blow-out vent piping as described in paragraph 2.1.

- 3.0 Vent and Overflow Piping for Diesel Generator Lube Oil Storage Tank, Cylinder Oil Storage Tanks and Cylinder Oil Day Tank
 - 3.1 Diesel generator lube oil storage tank
 - 3.1.1 Open diesel generator lube oil storage tank and lube oil purifier sludge tank. install blank at overflow piping and install air hose at vent opening. Remove vent screen as necessary to increase air velocity.
 - 3.1.2 Flush vent piping by blowing out with air at approximately 50 paig.
 - 3.1.3 During blowout, periodically vibrate the system with vibrators, wooden mallets or other equivalent means.
 - 3.1.4 Continue blowout until discharge into tank is visually free of foreign matter.
 - 3.1.5 Remove blank at overflow piping, reconnect piping and blank vent/overflow piping to tank.
 - 3.1.6 Flush overflow piping to sludge tank by blowing out with air at approximately 50 paig.

SIZE	NASSCO DRAWING NUMBER	REV
A	445-342-7141	A
SCALE:	NONE	SHEET 9

- 3.1.7 Continue blow out Until discharge into sludge tank is visually free of foreign matter.
- 3.1.8 After completion of blowout, remove air hose. Restore system piping as necessary.
- 3.2 Cylinder Oil Storage Tanks:
 - 3.2.1 Blow-out vent and overflow piping to lube oil purifier sludge tank as described in paragraph 3.1. Blow-out vents and overflows for both storage tanks.
- 3.3. Cylinder Oil Day Tank:
 - 3.3.1 Blow-out vent and overflow piping as described in paragraph 3.1 except discharge is to cylinder oil tank.
- 4.0 Deck Filling piping TO Lube Oil Tanks:
 - 4.1 Main engine lube oil storage tank.
 - 4.1.1 Open storage tank and install temporary flushing pump, duplex strainer, heater, hose jumpers and blanks as shown in Enclosure 1. Flushing path will be from deck fill connection to storage tank.
 - 4.1.2 Install muslin bags in the temporary duplex strainer. Fill the piping system with clean lube oil through the temporary strainer.
 - 4.1.3 Heat the lube oil to 160°-170°F and circulate the heated oil through the system piping.
 - 4.1.4 During circulation, periodically vibrate the system piping with vibrators, wooden mallets or other equivalent means.
 - 4.1.5 Inspect strainers and muslin bags and clean as necessary. Replace muslin bags when they become coated with foreign matter.
 - 4.1.6 Continue flushing until the muslin bags remain visually free of foreign matter.
 - 4.1.7 Shift flushing unit outlet to the other deck fill connection and repeat flush.

SIZE	NASSCO DORAWING NUMBER	REV
A	445-342-7141	A

- 4.1.8 After flushing of both deck fill paths is complete, remove temporary flushing equipment and restore system as necessary.

- 4.2 Diesel Generator Lube Oil Storage Tank:
 - 4.2.1 Flush deck fill piping as described in paragraph 4.1 using diesel generator lube oil.

- 4.3 Cylinder Oil Tanks:
 - 4.3.1 Flush deck fill piping as described in paragraph 4.1 using the initial flushing path for one tank as shown in Enclosure 2. Use cylinder oil. When initial flushing path is clean, operate valves to other tank fill connection to flush piping between tanks.
 - 4.3.2 Shift flushing unit outlet to other deck fill connection and repeat flush.
 - 4.3.3 After flushing is complete remove temporary flushing equipment and restore system as necessary.

- 5.0 Overflow And Sump Fill Piping For Lube Oil Tanks:
 - 5.1 Main engine lube oil storage tank and renovating tank overflow and sump fill.
 - 5.1.1 Open storage tank and lube oil sump and install temporary flushing pump, duplex strainer, heater, hose jumpers and blank flanges as shown in Enclosure 3. Flushing path will be from main engine lube oil sump fill line to overflow line.
 - 5.1.2 Install muslin bags in the temporary duplex strainers for the flushing pump strainer. Fill the piping system with clean lube oil through the temporary strainer.
 - 5.1.3 Heat the lube oil to 160° - 170° F and circulate the heated oil through the system piping.
 - 5.1.4 During circulation periodically vibrate the system piping with vibrators, wooden mallets or other equivalent means.
 - 5.1.5 inspect temporary strainer and muslin bag and clean as necessary. Replace muslin bags when they become coated with foreign matter.

SIZE	NASSCO DRAWING NUMBER	REV
A	445-342-7141	A
SCALE:	NONE	SHEET 1

- 5.1.6 Continue flushing until the muslin bags remain visually free of foreign matter.
- 5.1.7 Upon completion of flushing, shift discharge of temporary flushing unit to lube oil sump suction bellmouth. Install hose jumper in renovating tank between overflow line and suction piping as shown in Enclosure 4. Install blank flanges in vent piping or vent.
- 5.1.8 Repeat procedure of paragraph 5.1.2 through 5.1.6 to flush lube oil renovating tank overflow piping.
-  5.1.9 After flushing of overflow piping is complete shift hose jumper for renovating tank to connect inlet from lube oil transfer pump/purifier discharge to tank outlet as shown in Enclosure 18. Shift temporary flushing pump and strainer to bypass lube oil transfer pump. Remove lube oil transfer pump suction strainer and install spool piece.
- 5.1.10 Line up lube oil transfer pump piping to renovating tank to flush from renovating tank through temporary flushing pump to discharge to renovating tank. Fill system with lube oil, heat lube oil to 160° - 170° F and circulate the heated oil through the system piping.
- 5.1.11 During circulation periodically vibrate the system piping with vibrators, wooden mallets or other equivalent means.
- 5.1.12 Continue flushing until the muslin bags are visually free of foreign matter.
- 5.1.13 Upon completion of flushing remove temporary flushing unit and restore system as necessary. Clean and reinstall transfer pump suction strainer. Hose jumper for renovating tank should remain in place for flushing of purifier piping.

6.0 Main Engine Lube Oil Purifier Piping:

6.1 Renovating Tank.



- 6.1.1 Install temporary flushing pump and strainer at main engine lube oil purifier supply and return piping connections to flush purifier piping for renovating tank and piston rod stuffing box tank as shown in Enclosure 19.
- 6.1.2 Line up system to flush renovating tank purifier supply and return piping using hose jumper installed in paragraph 5.1.9. Fill system with lube oil and heat to 160° - 170° F and circulate the heated oil through the system piping.

SIZE	NASSCO DRAWING NUMBER	REV
A	445-342-7141	A
SCALE : NONE		SHEET 12

- 6.1.3 During circulation periodically vibrate the system piping with vibrators, wooden mallets or other equivalent means.
- 6.1.4 Continue flushing until muslin bags are visually free of foreign matter.
- 6.1.5 Upon completion of flushing, remove hose jumpers from renovating tank. If no further flushing or testing is to be conducted that requires tank *to* be open, clean tank and install cover.
- 6.2 Piston Bod stuffing Box Tank:
 - 6.2.1 With temporary flushing pump, strainer and heater installed at main engine lube oil purifier connections, line system up to flush supply and return piping for piston rod stuffing box drain oil filtration unit. Install hose jumper to connect supply and return piping at piston rod stuffing box tank.
 - 6.2.2 Fill system with lube oil, heat to 160° - 170° F and circulate the heated oil through the system piping.
 - 6.2.3 During **circulation** periodically vibrate the system piping with vibrators, wooden mallets or other equivalent means.
 - 6.2.4 Continue flushing until muslin bags are visually free of foreign matter.
 - 6.2.5 Upon completion of flushing, remove temporary flushing equipment and hose jumpers. Restore System as necessary.
- 7.0 Diesel Generator Lube Oil Pipings
 - 7.1 Diesel generator lube oil sump fill.
 - 7.1.1 Open diesel generator lube oil storage tank and install temporary flushing pump, strainer, heater, hose jumpers and blank flanges as shown in Enclosure 5.
 - 7.1.2 Install muslin bags in the temporary strainers. Fill the flushing piping system with diesel generator lube oil through the temporary strainer.
 - 7.1.3 Heat the diesel generator lube oil to 160° - 170° F and circulate the heated oil through the system piping.

SIZE	NASSCO DRAWING NUMBER	REV
A	445-342-7141	A
SCALE:	NONE	SHEET 13

- 7.1.4 During circulation periodically vibrate the system piping with vibrators, wooden mallets or other equivalent means.
- 7.1.5 Inspect atrainers and muslin bags and clean as necessary. Replace muslin bags when they become coated with foreign matter.
- 7.1.6 Continue flushing until the muslin bags remain visually free of foreign matter.
- 7.1.7 Shift flushing path to another diesel generator and repeat the flush. After the second diesel generator piping is flushed, shift the flushing path to the third diesel generator and repeat the flush.
- 7.1.8 Upon completion of flushing remove temporary flushing equipment and restore system as necessary. If no further flushing or testing is to be conducted that requires the storage tank to be open, clean tank and install cover.
- 7.2 Diesel Generator Lube Oil Sump Purification Piping:
 - 7.2.1 Install temporary flushing pump, strainer, heater, hose jumpers and blank flange to flush diesel generator lube oil sump purification piping. Install pump, strainer and heater at purifier piping connections for diesel generator lube oil. Install hose jumpers to bypass each diesel generator lube oil Bump.
 - 7.2.2 Line up system to flush one diesel generator's lube oil purification piping. Fill system with diesel generator lube oil, heat to 160° - 170°F and circulate heated oil through the system piping.
 - 7.2.3 During circulation periodically vibrate the system piping with vibrators, wooden mallets or other equivalent means.
 - 7.2.4 Continue flush until muslin bags are visibly free of foreign matter.
 - 7.2.5 Shift flushing path to another diesel generator and repeat the flush.
 - 7.2.6 After the second diesel generator lube oil lines are clean, shift the flushing path to the third diesel generator and repeat the flush.
 - 7.2.7 After flushing of all diesel generators purification piping is complete, remove temporary flushing equipment and restore system as necessary.
- 8.0 Diesel Generator Lube Oil Sump Vents:
 - 8.1 Disconnect vent piping at diesel generator lube oil sump. Install air hose at vent opening on weather deck. Remove vent screen as necessary to increase air velocity.



SIZE	NASSCO DRAWING NUMBER	REV
A	445-342-7141	A
SCALE :	NONE	SHEET 14

- 8.2 Flush vent piping by blowing out with air at approximately 50 psig supply pressure.
- 8.3 Continue blowout until discharge is visually free of foreign matter.
- 8.4 Upon completion of blowout, remove air hose, restore system as necessary.
- 9.0 Cylinder Oil Transfer Piping:
- 9.1 Open one cylinder oil tank and install temporary flushing pump, strainer, heater, hose jumpers and blank flanges as shown in Enclosure 6. install hose jumpers to bypass cylinder oil transfer pumps and a spool piece to replace installed strainer.
- 9.2 Install muslin bags in the temporary strainer, fill the system with cylinder oil, heat the oil to 160° - 170° F and circulate the heated oil through the system.
- 9.3 Flushing path will be from cylinder oil tank, bypassing one pump, through cylinder oil day tank, gravity fill to main engine cylinder lube oil connection and returning to the cylinder oil tank.
- 9.4 During circulation periodically vibrate the system piping with vibrators, wooden mallets or other equivalent means.
- 9.5 When muslin bags remain visually free of foreign matter, shift flow path to the other transfer pump piping and to the other cylinder oil tank by shifting the temporary flushing pump discharge from one cylinder oil tank to the other, continue flushing until muslin bags remain visibly free of foreign matter.
- 9.6 After flushing is complete, remove temporary flushing equipment and restore system as necessary. Clean and reinstall strainer. If no further flushing or testing is to be conducted that requires tanks to be open, clean tanks and install covers.
- 10.0 Lube oil Purifier Drainst
- 10.1 Open lube oil sludge tank. Blowout lube oil purifier drains to sludge tank prior to connecting drains to purifier.

SIZE	NASSCO DRAWING NUMBER	REV
A	445-342-7141	A
SCALE:	NONE	SHEET 15

10.2 Upon completion of blowout, if no further flushing or testing is to be conducted that requires the sludge tank to be open, clean sludge tank and install cover.

11.0 Lube Oil purifier Operating Water Head Tank Piping:

11.1 Flush operating water head tank piping to purifier connections prior to connecting to purifier by flushing with potable water. Continue flushing until discharge is visibly free of foreign matter.

11.2 Upon completion of flush restore system as necessary.

12.0 Deleted

13.0 Emergency Diesel Generator Lube Oil Sump Drain:

13.1 Open emergency diesel generator lube oil sump and blowout drain to lube oil purifier sludge tank.

13.2 Continue blowout until discharge is visibly free of foreign matter.

13.3 Upon completion of blowout, clean sump and install cover.

14.0 Lube Oil Fill, Transfer and Purification Drains:

14.1 Blowout all remaining system drains to the lube oil purifier sludge tank with air. This includes drip pan drains, funnel drains and vent drains. Blanks should be used to isolate sections of drains as needed to blow out individual sections.

SIZE	NASSCO DRAWING NUMBER	REV
A	445-342-7141	A
SCALE:	NONE	SHEET 16

- 14.2 Continue blowout until discharge is visibly free of foreign matter.
- 14.3 Upon completion of blowout, restore system as necessary.
- 15.0 Tank Cleaning:
- 15.1 When all flushing is complete for storage, renovating, sump and day tanks clean individual tanks and install covers.

SIZE	NASSCO DRAWING NUMBER	REV
A	445-342-7141	A
SCALE:	NONE	SHEET 17

LUBE OIL SERVICE SYSTEM
445-342-7106

1.0 General

1.1 Lube oil piping will be pickled. Prior to pickling the interior surfaces of piping and fittings will be wire brushed to the maximum extent possible and blown out with air to remove loose particles. After pickling piping and fittings will be sealed at the open ends. Valves will be blown clean with steam or air to remove loose scale, sand and welding beads. Open ends will be sealed after cleaning.

1.2 A clean lubricating oil system is essential in order to safeguard the equipment and assure proper operation.

The piping, coolers, filter's, Valves, etc., must be free of metal chips, rust, weld beads, scale, dirt, etc. Before filling the system with lube oil, the crankcase and lube oil sump, must be cleaned by hand to remove any residues left over after the installation work. Corrosion products and corrosion preventative compound that are revealed will be removed manually in-so-far as practicable, by means of wire brushes. Interior surfaces of the lube oil sump, and crankcase will be wiped clean of corrosion preventative compound and other impurities by lintless cloth soaked in cleaning oil. Care should be taken to ensure that the self-cleaning strainer is clean. At completion of inspection and manual cleaning, all inspection and cleanout covers that were temporarily removed will be reinstalled.

1.3 The main engine lube oil purification system will be installed, flushed and ready for operation.



1.4 Main engine lube oil pumps will be used to circulate lube oil during flushing. Muslin bags will be installed in pump suction strainers. Pump suctions will be checked for cleanliness prior to final installation. Lube oil suction bellmouths and lube oil sump tank will be checked for cleanliness prior to filling the sump with lube oil.

1.5 Installed or temporary ventilation will be in operation during flushing.

1.6 Whenever any inspection cover, tank cover, piping or other part is open for any length of time, the opening will be covered to prevent the entry of foreign matters.



1.7 System oil is to be used for the flushing oil. System oils are listed in Reference 1. Upon satisfactory completion of flushing the flushing oil is to be removed from the system.

SIZE	NASSCO DRAWING NUMBER	REV
A	445-342-7141	A
SCALE:	NONE	SHEET 18

2.0 Main Engine Lube Oil Service System

2.1 The initial flushing of the main engine lube oil system will bypass the main lube oil cooler, self-cleaning strainer and main engine. Temporary strainers will be installed to remove foreign matter from the system.

2.2 Self-Cleaning Strainer Backflush Drain Line and Lube Oil Outlet from Turbo Charger

2.2.1 Install a temporary flushing pump, strainer, heater and hose jumpers to flush the self-cleaning strainer backflush drain line and main engine lube oil outlet from turbocharger piping. Temporary strainers will be installed at the lube oil sump.



2.2.2 Install muslin bags in temporary strainers. Fill piping with lube oil, heat to 120°-130° F and circulate heated oil through piping. Continue flush until muslin bags are visibly free of foreign matter.

2.2.3 Upon completion of flushing, remove temporary flushing equipment, reconnect piping.

2.3 Lube oil sump Tank vents

2.3.1 Blow-out lube oil sump tank vents with air if not previously accomplished. Remove vent screen to increase air velocity if necessary.

2.4 Main Engine Lube Oil System Bypassing Cooler, Self-Cleaning Strainer and Main Engine.

2.4.1 Install temporary strainers, hose jumpers, spool pieces and blanks as shown on Enclosure 7. Remove Lube oil cooler bypass valve and install spool piece to bypass cooler. Remove cooler bypass orifice and install spool piece. A check bag of 50 micron filter gauze, approximately 4 inches in diameter and 16 inches in length, will be installed at the end of a hose connected to the one inch hose connection between the lube oil pump discharge and cooler. The bag is contained in a mesh or perforated cover and suspended in the crankcase.

SIZE	NASSCO DRAWING NUMBER	REV
A	445-342-7141	A
SCALE	SHEET	

2.4.2 Install muslin bags in the temporary and installed strainers. Verify lube oil sump and lube oil piping suction piping have been cleaned.



2.4.3 Fill lube oil sump with lube oil through a 50 micron strainer to above the low level alarm point. Operate the main engine lube oil purifier and heat the lube oil to 120°-130°F. Steam heating coils in the lube oil sump may also be used. The purifier will be in operation throughout the flushing procedure.

2.4.4 Operate one lube oil pump and circulate the heated oil through the system bypassing the cooler, self-cleaning strainer and main engine. Operate the lube oil pump discharge pressure regulating valve to flush the valve piping. Operate the valves for the self-cleaning strainer to provide full flow through the self-cleaning strainer piping and bypass strainer piping.

2.4.5 During circulation periodically vibrate the system piping using vibrators, wooden mallets or other equivalent means.

2.4.6 Continue flushing until muslin bags are visibly free of foreign matter for a period of two hours. This includes the check bag suspended in the crankcase.

2.4.7 Repeat the flushing process using the other lube oil pump.



2.4.8 Upon completion of flushing, remove hose jumper at self-cleaning strainer, reconnect strainer. Clean piping to cooler not included in flush. Visually check cooler piping connections for cleanliness. Remove spool piece at cooler and reinstall regulating valve.

2.5 Main Engine Lube Oil System Including Cooler, and Strainers, bypassing the Main Engine

2.5.1 Line up system to flush piping through cooler, self-cleaning strainer, bypassing main engine. Install muslin bags in temporary and installed strainers.



2.5.2 Operate main engine lube oil purifier on main engine lube oil sump. Heat lube oil to 120°-130°F using purifier or sump heating coils.

SIZE	NASSCO DRAWING NUMBER	REV
A	445-342-7141	A
SCALE		SHEET

- 2.5.3 Circulate heated lube oil through system using one lube oil pump. Cycle all regulating valves and strainer valves to provide flow through cooler, self-cleaning and bypass strainers. Check that self-cleaning strainer is operating properly.
- 2.5.4 During circulation periodically vibrate system piping with vibrators, wooden mallet or other equivalent means.
- 2.5.5 Continue flushing until muslin bags in strainers are visibly free of foreign matter for a period of two hours. Use the other lube oil pump and repeat the flushing process.
- 2.5.6 Before stopping flushing, obtain a representative lube oil sample and send to a laboratory for a particulate count. The sample will meet the cleanliness standard of SAE, Class 5. If cleanliness standard is not met repeat flushing procedures until cleanliness is satisfactory.

- 2.6 Main Engine Lube Oil System Bypassing Bearings
 - 2.6.1 Remove discharge hose jumpers from crankcase for turbocharger and piston cooling oil and bearing oil supply. Connect the lube oil supply to the turbocharger piston cooling and bearings so the temporary strainers remain in the piping as shown in Enclosure 8.
 - 2.6.2 Bypass bearings in the main engine by blanking off the branch pipes to the main bearings in the crankcase, the bearings in the chain box, the thrust bearing and using special adapter plates, the inlet to the crosshead. Install a check bag filter on one lube oil pipe inside the engine, main bearing and outmost telescopic pipe.
 - 2.6.3 Install muslin bags in temporary and installed strainers. Operate the purification system on the lube oil sump.
 -  2.6.4 Heat lube oil to 120°-130° F and circulate the oil through the system. Continue flushing until muslim bags and check bags are visibly free of foreign matter for a period of two hours. During circulation vibrate system piping not previously vibrated by means of vibrators, wooden mallets or other equivalent means.
 - 2.6.5 Upon completion of flushing, remove special adaptors and checkbags. Install all piping to bearings and crosshead.

SIZE	NASSCO DRAWING NUMBER	REV
A	445-342-7141	A
SCALE	NONE	SHEET 21

2.7 Main Engine Lube Oil System Including Bearings



- 2.7.1 install clean muslin bags in installed and temporary strainers. Heat lube oil to 120°-130° F and circulate heated oil through system piping.
- 2.7.2 During circulation main engine should be periodically rotated with the turning gear. Check bearing parts and spray nozzles for proper flow.
- 2.7.3 Continue flushing until muslin bags remain visibly free of foreign matter for a period of two hours.
- 2.7.4 Upon completion of flushing, remove temporary strainers at main engine lube oil supply for turbocharger and bearings. Connect lube oil supply piping to main engine.
- 2.7.5 Operate lube oil service pumps and flush system until muslin bags remain visibly free of foreign matter for a period of two hours. During circulation periodically rotate the main engine with the turning gear.
- 2.7.6 Upon completion of flushing, secure purification, drain system, open and clean lube oil sump. Remove muslin bags, reinstall orifices, clean strainers and restore system as necessary.
- 2.7.7 The time interval between the removal of the flushing oil, cleaning the system and the refilling of the system with lube oil will be kept to a minimum to prevent rusting.

SIZE	NASSCO DRAWING NUMBER	REV
A	445-342-7141	A
SCALE:	NONE	SHEET 2 2

CAMSEAR LUBE OIL SERVICE

445-342-7134

1.0 General:

1.1 Flushing path will include shipyard installed piping only.

1.2 Lube oil piping will be pickled. Prior to pickling the interior surfaces of piping and fittings will be wire brushed to the maximum extent possible and blown out with air to remove loose particles. After pickling piping and fittings will be sealed at the open ends. Valves will be blown clean with steam or air to remove loose scale, sand and welding beads. Open ends will be sealed after cleaning.

1.3 A clean lubricating oil system is essential in order to safeguard the equipment and assure proper operation.

The piping must be free of metal chips, rust, weld beads, scale, dirt, etc. Corrosion products and corrosion preventative compound will be removed manually insofar as practicable, by means of wire brushes.



1.4 System oil is to be used for the flushing oil. System oils are listed in Reference 1. Upon satisfactory completion of flushing the flushing oil is to be removed from the system.

2.0 Comshaft Lube Oil Semite Flushing:

2.1 Install temporary flushing pump, duplex strainer with magnets, heater, hose jumpers and blank flanges to bypass camshaft lube oil unit and main engine.

2.2 Install muslin bags in the temporary duplex strainers. Fill the piping system with clean lube oil through the temporary strainers.



2.3 Heat the lube oil to 120-130°F and circulate the heated oil through the system piping.

2.4 During circulation, periodically vibrate the system piping with vibrators, wooden mallets or other equivalent means.

2.5 Inspect strainers and muslin bags and clean as necessary. Replace muslin bags when they become coated with foreign matter.

2.6 Continue flushing until the muslin bags-remain visibly free of foreign matter for a period of two hours.

2.7 Before stopping flushing, obtain a representative lube oil sample and send to a laboratory for a particulate count. The sample will meet the cleanliness standard of SAE, Class 5. If cleanliness standard is not met, repeat flushing procedures until cleanliness is satisfactory.

2.8 After flushing is complete, remove temporary flushing equipment and restore systems as necessary for operation or testing.

SIZE	NASSCO DRAWING NUMBER	REV
A	445-342-7141	A
SCALE:	NONE	SHEET 23

4.5 Continue flushing until the muslin bags remain visibly free of foreign matter.

4.6 After flushing is complete, remove temporary flushing equipment and restore system as necessary.

SIZE	NASSCO DRAWING NUMBER	REV
A	445-342-7141	A
SCALE:	NONE	SHEET 25

MAIN ENGINE LUBE OIL STUFFING BOX,
AIR COOLER, AND SCAVENGING AIR DRAIN SYSTEMS
 445-342-7135

1.0 General:



1.1 Piping sections may be cleaned in the shop or onboard. These sections will be included in system flushing as provided for in the flushing procedures.



1.2 System oil is to be used for the flushing oil. System oils are listed in Reference 1. Upon satisfactory completions of flushing the flushing oil is to be removed from the system.

2.0 Piston Rod Stuffing Box Oil Filtration Unit Drains:

2.1 Disconnect drain line from oil filtration unit at the waste oil tank. Disconnect drain lines from circulating tank and from drain tank.

2.2 Flush drain piping from circulating and drain tanks and funnel drain line to waste oil tank connection by blowing out with air at approximately 50 psig supply pressure.

2.3 Continue blow-out until the discharge is visibly free of foreign matter.

2.4 After completion of blow-out, remove air hose. Reconnect piping as necessary.

3.0 Scavenge Air Box Drain:

3.1 Repeat Paragraph 2.0 for scavenge air box drains from the main engine to the scavenge air box drain collection tank waste oil tank. Also blow-out collection tank vent. Remove vent screen as necessary to increase air velocity.

4.0 Piston Rod Stuffing Box Drain Oil Filtration Unit:



4.1 Install temporary flushing pump, strainer, and heater to flush clean oil return line to main engine lube oil sump by disconnecting return piping at filtration unit and at return to lube oil sump as shown in Enclosure 20.



4.2 Install muslin bags in the temporary duplex strainers, fill system with lube oil, heat lube oil to 160°-170°F and circulate the heated oil through the system.

4.3 During circulation periodically vibrate the system piping with vibrators, wooden mallets or other equivalent means.

4.4 Inspect strainers and muslin bags and clean as necessary. Replace muslin bags when they become coated with foreign matter.

SIZE	NASSCO DRAWING NUMBER	REV
A	445-342-7141	A
SCALE: NONE		SHEET 24

STERN TUBE LUBE OIL SYSTEM
445-342-7129

1.0 General:

1.1 Lube oil piping will be pickled. Prior to pickling the interior surfaces of piping and fittings will be wire brushed to the maximum extent possible and blown out with air to remove loose particles. After pickling piping and fittings will be sealed at the open ends. Valves will be blown clean with steam or air to remove loose scale, sand and welding beads. Open ends will be sealed after cleaning.

1.2 A clean lubricating oil system is essential in order to safeguard the equipment and assure proper operation.

The piping and valves must be free of metal chips, rust, weld beads, scale, dirt, etc. Before filling the system with lube oil the lube oil sump, and head tanks must be cleaned by hand to remove any residues left over after the installation work. Corrosion products and corrosion preventative compound will be removed manually insofar as practicable, by means of wire brushes.

1.3 Whenever any inspection cover, tank cover, piping or other part is open for any length of time, the opening will be covered to prevent the entry of foreign matter.



1.4 System oil is to be used for the flushing oil. System oils are listed in Reference 1. Upon satisfactory completion of flushing the flushing oil is to be removed from the system.

2.0 Forward Seal Lube Oil System

2.1 Disconnect forward vent seal piping at seal and blow-out forward seal vent line with 50 psig air. Continue blow out until discharge is visibly free of foreign matter. Reconnect piping.

2.2 Install temporary flushing pump, duplex strainer with muslin bags, and hose jumper to bypass forward seal head tank and recirculating Pump Unit and forward seal. Flushing path will be through supply line, bypassing forward seal, through lube oil return and bypassing tank and pump unit.

2.3 Flush lube oil system with temporary pump. Continue flushing until muslin bags are visibly free of foreign matter for a period of two hours.

2.4 During circulation, periodically vibrate the system piping with vibrators, wooden mallets, or other equivalent means.

2.5 Upon completion of flush, remove temporary flushing pump, strainers, and hose jumper. Restore system as necessary.

SIZE	NASSCO DRAWING NUMBER	REV
A	445-342-7141	A
SCALE:	NONE	SHEET 26

- 3.0 Tailshaft Stern Tube Pipings
- 3.1 All piping aft of frame 106 will be flushed prior to stern tube bearing, tailshaft and seal installation.
- 3.2 Blow-out vent lines for stern tube vent and "ASLOS" vent with 50 psig air.
- 3.3 Install temporary flushing pump, temporary strainer with muslin bags, and hose jumpers to flush piping sections aft of Frame 106 of the stern tube head tank and "ASLOS" head tank connection, aft bearing supply and cavity drain line. Install hose jumper across stern tube cavity between stern tube head tank supply and cavity drain.
- 3.4 Continue flushing until muslin bags remain visibly free of foreign matter.
- 3.5 Upon completion of flush, remove temporary flushing pump, strainers, and hose jumpers. Inspect and clean all surfaces and openings by hand before bearing and shaft installation.
- 4.0 Stern Tube and "ASLAS" Head Tank Piping:
- 4.1 Blow-out with 50 psig air the vent piping for the stern tube vents stern tube lube oil head tank, "ASLOS" vent, stern tube lube oil tank sump tank vent, and stern tube lube oil head tank overflow.
- 4.2 Install temporary flushing pump, temporary strainer with muslin bags, hose jumpers, and blanks as shown in Enclosure (9). Initial flush will be piping to aft bearing, stern tube lube oil head tank, cavity supply to stern tube recirc/drain line.
- 4.3 Fill stern tube lube oil head tank and system with lube oil. Flush stern tube head tank lube oil system.
- 4.4 During circulation, periodically vibrate the system piping with vibrators, wooden mallets, or other equivalent means.
- 4.5 Continue flush until muslin bags are visibly free of foreign matter.
- 4.6 Upon completion of flush of stern tube lube oil head tank shift flushing path to "ASLOS" head tank and flush. Flow path will be piping to aft bearing, "ASLOS" head tank to aft seal supply.
- 4.7 Upon completion of flush, remove temporary flushing pump) strainers hose jumpers, and blanks. Open and clean stern tube lube oil head tank and "ASLOS" head tank. Restore system as necessary.

SIZE	NASSCO DRAWING NUMBER	REV
A	445-342-7141	A
SCALE NONE		SHEET 27

FUEL OIL AND DIESEL OIL FILLING AND TRANSFER SYSTEM
INCLUDING SLUDGE HANDLING
 445-342-7114

1.0 General:



1.1 Piping sections may be cleaned in the shop or onboard. These sections will be included in system flushing as provided for in the flushing procedure.



1.2 Upon completion of flushing, diesel oil is to be removed from the system. This diesel oil may be purified and used for fuel.

2.0 Diesel Oil Storage Tank Filling Piping and Vents:

2.1 Open diesel oil storage tanks. Blow-out filling piping from deck connections to tank using 50 psig air. Blow-out vent piping for each tank. Vent screens may be removed to increase velocity.

2.2 During blow-out, periodically vibrate system piping using vibrators, wooden mallets, or other means.

2.3 Continue blow-out until discharges are visibly free of foreign matter.

2.4 Upon completion of blow-out, clean diesel oil storage tanks. Restore vent system.

3.0 Fuel Oil Storage Tank Filling Piping and Vents:

3.1 Open all fuel oil storage tanks and waste oil tank. Blow-out filling piping from deck connections to tanks using 50 psig air. Blow-out vent piping for each tank. Vent screens may be removed to increase velocity.

3.2 During blow-out, periodically vibrate system piping using vibrators, wooden mallets, or other equivalent means.

3.3 Continue blow-out until discharges are visibly free of foreign matter.

3.4 Upon completion of blow-out, clean fuel oil storage tanks. Restore vent system.

4.0 Banker Station Drain to Waste Oil Tanks:

4.1 Blow-out bunker station drains to waste oil tank as outlined above in Paragraph 3.0.

SIZE	NASSCO DRAWING NUMBER	REV
A	445-342-7141	A
SCALE	NONE	SHEET 28

- 5.0 Fuel oil Tank Vents and Overflows:
- 5.1 Open the clarified oil and both oil/water decanting tanks. Blow-out vent and overflow piping as outlined in Paragraph 3.0.
- 6.0 Diesel Oil Transfer Piping:
- 6.1 Install muslin bag in diesel oil transfer pump suction strainer. Install hose jumpers in diesel oil storage tanks from fill piping to suction.
- 6.2 Line up diesel oil transfer pump to flush diesel oil storage tank through pump to discharge to tank. Fill system with diesel oil.
- 6.3 Operate diesel oil transfer pump and continue flushing until muslin bag is visibly free of foreign matter.
- 6.4 Repeat flush using other diesel oil storage tank.
- 6.5 Upon completion of flush, remove hose jumpers and restore system as necessary.
- 7.0 Fuel Oil Transfer Piping:
- 7.1 Open fuel oil storage wing tanks, fuel oil storage tank, fuel oil overflow tank, fuel oil settling tank, and engine room overflow tank. Install muslin bag in fuel oil transfer pump suction strainer.
- 7.2 Line Up fuel oil transfer system to flush from one fuel oil storage wing tank to fuel oil transfer pump through fuel oil storage tank fill piping to storage wing tank.
- 7.3 Fill system with diesel oil. Operate fuel oil transfer pump to flush system.
- 7.4 Continue flush until muslin bag is visibly free of foreign matter.
- 7.5 Upon completion of flushing of one storage tank, repeat Paragraphs 7.2 through 7.4 for remaining fuel oil storage wing tanks.
- 7.6 For fuel oil overflow tank, fuel oil storage tank, fuel oil settling tank, and engine room overflow tank, if the tank transfer piping to the transfer main can be visually inspected for cleanliness, this piping need not be flushed. If transfer piping connections to these tanks can not be checked, piping should be flushed as follows .

SIZE	NASSCO DRAWING NUMBER	REV
A	445-342-7141	A
SCALE	NONE	SHEET 29

- 7.7 Rundown or transfer diesel oil from fuel oil storage wing tank to tank. Install hose jumper from fuel oil trmsfer pump discharge to tank to be flushed.
- 7.8 Operate fuel oil transfer pump to flush transfer piping from tank.
- 7.9 Continue flush until muslin bag is visibly free of foreign matter.
- 7.10 Upon Completion of flush, repeat for other tanks as necessary.
- 7.11 When all fuel oil transfer piping has been flushed, remove hose jumper and clean all tanks.

- 8.0 Sludge Pump Transfer Pipings
- 8.1 Open and clean waste oil tank and general service sludge oil tank.
- 8.2 Install hone jumper from discharge of sludge transfer pump into one tank. Install muslin bag in sludge pump suction strainer.
- 8.3 Fill tank with sufficient diesel oil for sludge pump operation. Operate sludge pump to flush pump suction piping.
- 8.4 Continue flush until muslin bag is visibly free of foreign matter.
- 8.5 Upon completion of flush, shift line Up and discharge of hose jumper to the other tank. Repeat Paragraphs 8.2 through 8.4.
- 8.6 After suction piping for both tanks has been flushed remove hose jumper at discharge of sludge pump. Reconnect piping.
- 8.7 Open and clean clarified oil and oil/water decanting tanks. Line up sludge transfer system to take suction on one tank and discharge to same tank. Install muslin bag in pump suction strainer. Transfer flushing oil to tank.
- 8.8 Operate sludgt transfer pump to flush tank suction piping. Continue flush until muslin bag is visibly free of foreign matter.
- 8.9 Upon completion of flush, shift flushing to remaining tank and repeat Paragraphs 8.7 to 8.8. Include both high and low suctions.
- 8.10 Upon completion of flush, clean all tanka.

SIZE	NASSCO DRAWING NUMBER	REV
A	445-342-7141	A
SCALE: NONE		SHEET 30

FUEL OIL AND DIESEL OIL PURIFICATION AND SERVICE SYSTEM
445-342-7115

1.0 General:



1.1 Piping sections may be cleaned in the shop or onboard. These sections will be included in system flushing as provided for in the flushing procedures.

1.2 Since tanks may be involved in more than one flushing path, all flushing procedures for piping connected to tanks should be complete prior to final cleaning and closure.



1.3 Upon completion of flushing, diesel oil is to be removed from the system. This diesel oil may be purified and used for fuel.

2.0 Fuel Oil Purification Piping

2.1 Open fuel oil settling tank. Install temporary flushing pump, strainer with muslin bags, hose jumper and heater as shown in Enclosure 10.

2.2 Fill system with diesel oil. Operate temporary flushing pump.

2.3 Continue flushing until muslin bags are visually free of foreign matter. During circulation periodically vibrate system piping with vibrators, wooden mallets or other equivalent means.

2.4 Upon completion of flushing, shift discharge of temporary flushing pump to purifier discharge piping to fuel oil service tank. Install hose jumper in fuel oil service tank.

2.5 Line up system to flush fuel oil service tank purification piping through fuel oil service tank. Fill system with diesel oil. Operate temporary flushing pump. Continue flushing until muslin bags are visually free of foreign matter.

2.6 Upon completion of flushing, remove temporary flushing equipment, clean tanks and restore system as necessary.

3.0 Diesel Oil Purification Piping

3.1 Open diesel oil storage tanks and diesel oil service tank. Install temporary flushing pump and strainer with muslin bags as shown in Enclosure 11. Install hose jumper between service tank and storage tank.

3.2 Fill system with diesel oil and operate temporary flushing pump to flush purification piping.

3.3 Continue flushing until muslin bags are visibly free of foreign matter.

SIZE		REV
A	445-342-7141	A
SCALE:	NONE	SHEET 31

- 3.4 After flushing one storage tank, shift hone jumper to the other diesel oil storage tank and repeat flush.
- 3.5 Upon completion of flushing, remove temporary flushing equipment, clean tanks and restore system as necessary.

- 4.0 Fuel Oil Service
- 4.1 Install temporary flushing pump, strainer with muslin bags, hose jumpers and blanks as shown on Enclosure 12. Bypass main engine and heavy fuel unit.
- 4.2 Fill system with diesel oil. Line up system to flush main engine fuel oil supply and return piping to fuel oil service tank.
- 4.3 Operate temporary flushing pump and flush system until muslin bags in strainers are Visibly free of foreign matter. During flush operate back pressure regulating valve bypass to flush bypass line. Clean installed strainers as necessary.
- 4.4 Upon completion of flush, leave temporary flushing equipment installed. Leave hose jumpers installed on main engine. Temporary flushing equipment will be used in flushing of diesel oil to fuel oil cross-connects.

- 5.0 Diesel Oil Service
- 5.1 Open SSDG diesel oil emergency head tank, emergency diesel generator diesel oil day tank and diesel oil service tank. Install hose jumper between suction piping and return piping in diesel oil service tank and in SSDG diesel oil emergency head tank.
- 5.2 Blow out overflow piping from head tank and day tank to service tank.
- 5.3 Install hose jumpers on each diesel engine between diesel oil supply and return to bypass the diesel engine. Install muslin bags in diesel oil service pump suction strainer.
- 5.4 Line up system to flush from diesel oil service tank using service pumps to diesel engine and back to service tank.
- 5.5 Operate service pump to flush one diesel at a time. Continue flushing until muslin bags are visibly free of foreign matter. Alternate service pumps to flush piping for both pumps.

SIZE	NASSCO DRAWING NUMBER	RE
A	445-342-7141	A
SCALE	NONE	SHEET 32



- 5.6 Upon completion of flushing of each diesel supply and return piping, line up flow path to flush suction and return piping to SSDG diesel oil emergency head tank and repeat flush. After flush is complete, leave system hose jumpers installed in diesel service tank and diesel engines.
- 5.7 install hose jumper from inlet to emergency diesel generator diesel oil day tank to diesel oil service pump suction strainers. Line up to flush piping for emergency diesel generator diesel oil day tank. Operate diesel oil service pump to flush system. Continue flush until muslin bags are visibly free of foreign matter.
- 5.8 Using temporary flushing pump installed in fuel oil system, paragraph 4.0, line up fuel oil and diesel oil system to flush through to diesel generators and return to fuel oil service tank. Remove strainers and regulating valve in fuel oil supply from fuel unit to diesel
- 5.9 **Operate temporary flushing pump in the fuel oil system and continue flushing until muslin bags in temporary suction strainers in fuel oil system are visibly free of foreign matter.**
- 5.10 Shift flushing path to use diesel oil service tank.. Continue flushing until muslin bags in strainers are visibly free of foreign matter.
- 5.11 Upon completion of flushing remove temporary flushing equipment, hose jumpers and restore fuel oil and diesel oil systems as necessary. Clean all tanks used in the flushing process.

SIZE	NASSCO DRAWING NUMBER	REV
A	445-342-7141	A
SCALE	NONE	SHEET 33

FUEL OIL AND DIESEL OIL SYSTEM, AUXILIARY BOILER
445-342-7136

1.0 General:

1.1 This flushing procedure uses system pumps and strainers. Suction piping of pumps must be clean and free of debris prior to operation of pump.



1.2 Upon completion of flushing, diesel oil is to be removed from the system. This diesel oil may be purified and used as fuel.

2.0 Auxiliary Boiler Fuel Oil Service Piping:

2.1 Install hose jumpers and blank flanges as shown in Enclosure 13. Bypass boiler fuel oil heater and boiler. Remove return line strainer and regulating valve and install spool pieces. Open and clean fuel oil settling tank.

2.2 Install muslin bags in fuel oil service pump suction strainers.

2.3 Fill piping system with diesel oil.

2.4 Flush the system using the fuel oil service pump. Operate return line regulating valve bypass valve to flush the bypass line.

2.5 During circulation, periodically vibrate the system piping with vibrators, wooden mallets, or other equivalent means.

2.6 Inspect strainers and muslin bags and clean as necessary. Replace muslin bags when they become coated-with foreign matter.

2.7 Continue flushing until muslin bags remain visibly free of foreign matter.

2.8 Clean deadend lines by hand or remove blank flanges between boiler fuel oil heater and return line and flush until muslin bags remain visibly free of foreign matter.

2.9 Clean piping from sludge transfer pump suction to fuel oil service pump suction strainer by hand or install hose jumpers from return line to suction piping and flush.

2.10 After flushing is complete, remove hose jumpers and blank flanges. Restore system as necessary. Clean fuel oil settling tank.

3.0 Auxiliary Boiler Diesel Oil Service Piping

3.1 Install hose jumpers and blank flanges as shown in Enclosure 14. Open one die-sel oil storage tank.

SIZE	NASSCO DRAWING NUMBER	REV
A	445-342-7141	A
SCALE	NONE	SHEET 34

- 3.2 Install muslin bags in pump suction strainer. Remove recirculation line strainer and regulating valve and install spool pieces.
- 3.3 Fill the piping system with diesel oil.
- 3.4 Flush the *system* using the diesel oil service pump. Operate recirculation valves and bypass to flush recirculation piping.
- 3.5 During circulation, periodically vibrate the system piping with vibrators, wooden mallets, or other equivalent means.
- 3.6 Inspect strainers and muslin bags and clean as necessary. Replace muslin bags when they become coated with foreign matter.
- 3.7 Continue flushing until muslin bags remain visibly free of foreign matter.
- 3.8 Shift flushing path to the second diesel storage tank and repeat the flush.
- 3.9 After flushing is complete, remove hose jumpers and blank flanges. Clean and reinstall recirculation strainer and regulating valve.
- 4.0 Auxiliary Boiler Diesel Oil Ignition/Pilot Pump Piping:
- 4.1 Install hose jumpers and blank flanges as shown in Enclosure 15.
- 4.2 Install muslin bag in diesel oil ignition/pilot pump suction strainers. Fill the system with diesel oil.
- 4.3 Flush the system using the ignition/pilot pump as described in Paragraphs 3.5 through 3.7.
- 4.4 After flushing is complete, remove temporary flushing equipment and restore system as necessary. If diesel oil storage tank is not required for further flushing operations, clean tank and install covers.



SIZE	NASSCO DRAWING NUMBER	REV
A	445-342-7141	A
SCALE	NONE	SHEET 35

EMERGENCY DIESEL GENERATOR SERVICES SYSTEM

445-342-7137

1.0 General:

1.1 Emergency diesel generator diesel oil day tank vent and overflow flushing will be conducted under vents, sounds and overflow systems or diesel oil fill and transfer system.



1.2 Upon completion of flushing, diesel oil is to be removed from the system. This diesel oil may be purified and used as fuel.

2.0 Emergency Diesel Generator Diesel Oil:

2.1 Install temporary flushing pump and strainer with muslin bags to flush diesel oil supply and return piping from connections to emergency diesel to day tank. Hose jumpers may be installed in day tank or day tank filled with diesel oil.

2.2 Line up system to flush through supply piping to return piping. Fill system with diesel oil and operate temporary flushing pump and flush system.

2.3 During circulation, periodically vibrate the system piping with vibrators, wooden mallets, or other equivalent means.

2.4 Continue flush until muslin bags in strainers remain visibly free of foreign matter.

2.5 Upon completion of flush, remove temporary flushing equipment and hose jumpers. Restore system as necessary. Clean day tank.

3.0 Emergency Diesel Generator Combustion Exhaust:

3.1 Visually check diesel exhaust ducting for cleanliness prior to final hookup. Clean as necessary.

SIZE	NASSCO DRAWING NUMBER	REV
A	445-342-7141	
SCALE:	NONE	SHEET 36

AUXILIARY STREAM SYSTEM
445-342-7113

SERVICE STEAM SYSTEM
445-342-7127

FUEL OIL AND LUBE OIL TANK HEATERS SYSTEM
445-342-7130

- 1.0 General:
 - 1.1 Steam piping will be flushed using steam from the auxiliary boiler. The boiler will be brought up to operating pressure prior to cleaning the steam piping.
 - 1.2 Service steam, tank heating, and auxiliary steam systems will be cleaned by blowing down with steam at system operating pressure prior to making Up pipe to equipment served. As an alternative shore steam may be used.
- 2.0 Steam system Pipings
 - 2.1 All connections to equipment served will be broken down and all valves will be opened fully. Control valves will be removed or bypassed. Low points such as heating coils must be opened and flushed from steam and condensate sides.
 - 2.2 Open boiler main stop valve and discharge steam through the piping and the open connection to the space. Conduct this operation with extreme safety precaution.
 - 2.3 Continue flushing until discharges are visibly free of foreign matter.
 - 2.4 After completion of flush all strainers and trap strainers will be cleaned. Connect piping as necessary.

SIZE	NASSCO DRAWING NUMBER	REV
A	445-342-7141	A
SCALE:	NONE	SHEET 37

AUXILLARY BOISTER FEED AND EXHAUST GAS BOILER CIRCULATING SYSTEM
445-342-7120

- 1.0 General:
 - 1.1 Flushing of feed and circulating system uses installed pumps and strainers and temporary strainers. During pump operation monitor pumps closely to prevent damage to pumps. Ensure strainers and muslin bags are in place and visibly free of foreign matter.
- 2.0 Auxilary Boiler Feed System:
 - 2.1 Install temporary strainers with muslin bags, hose jumpers, blank flanges, and spool pieces as shown in Enclosure 16. Open and clean cascade tank.
 - 2.2 Fill cascade tank and system with clean fresh water.
 - 2.3 Line up system to flush from cascade tank through boiler feed pumps to auxiliary boiler inlet to cascade tank.
 - 2.4 Flush system using one pump until strainers and muslin bags remain visibly free of foreign matter. Operate chemical feed tank valves to flush chemical feed tank. Shift from one pump to the other pump to flush piping for both pumps.
 - 2.5 Line up system to flush pump bypass recirculation piping and flush back to cascade tank.
 - 2.6 After flush is complete, remove temporary strainers, hose jumpers, blank flanges, and spool pieces. Restore system for operation or testing. If cascade tank is not required for further flushing procedures, clean tank and close covers.
- 3.0 Exhaust Gas Circulating System:
 - 3.1 Install temporary strainers with muslin bags, hose jumpers and blank flanges as shown in Enclosure 17. Clean suction piping for circulating pump.
 - 3.2 Fill system with clean fresh water.
 - 3.3 Line up system to flush from circulating pumps to exhaust gas boiler to auxiliary boiler back to pumps.
 - 3.4 Flush system using one pump until strainers and muslin bags remain visibly free of foreign matter. Shift from one pump to the other pump.
 - 3.5 After flushing is complete, remove temporary strainers, hose jumpers, and blank flanges. Restore system as necessary.

SIZE	NASSCO DRAWING NUMBER	REV
A	445-342-7141	
SCALE:	NONE	SHEET 38

CONDENSATE, FRESH WATER AND CONTAMINATED STEAM

445-342-7123

- 1.0 General:
 - 1.1 condensate and drain systems may be flushed with steam or fresh water. Steam will be from the auxiliary boiler at operating pressure. As an alternative shore steam may be used.
- 2.0 Contaminated Steam Draining:
 - 2.1 Using steam or fresh water, flush piping from components to the contaminated steam drain tank. Bypass the steam drain cooler.
 - 2.2 Continue flushing until the discharge is visibly free of foreign matter.
 - 2.3 Upon completion of flushing, restore system as necessary. Clean contaminated steam drain tank.
- 3.0 Condensate:
 - 3.1 Using steam or fresh water, flush piping from components to the cascade tank. Bypass the combined atmospheric dump condenser/drain cooler.
 - 3.2 Continue flushing until the discharge is visibly free of foreign matter.
 - 3.3 Upon completion of flushing, restore system as necessary.
- 4.0 Freshwater
 - 4.1 Using installed pumps or temporary flushing pump, flush fresh-water system from distilled water tank to units involved with freshwater. Disconnect piping at units and flush until discharge is visibly free of foreign material.
 - 4.2 Upon completion of flushing, restore system as necessary. Clean cascade and distilled water tanks.

SIZE	NASSCO DRAWING NUMBER	REV
A	445-342-7141	A
SCALE:	NONE	SHEET 39

AUXILLIARY BLOWDOWN AND S Y S T E M
445-342-7M1

- 1.0 General:
 - 1.1 Flushing of auxiliary boiler blowdown piping, auxiliary boiler, and exhaust gas boiler escape steam and shore and steam relief piping will be conducted prior to operation of the auxiliary boiler or exhaust gas boiler.
 - 1.2 Air will be used to verify blowdown and escape stem piping is free of obstructions and debris. Normal operating pressure of 102 paig should not be exceeded.
- 2.0 Auxiliary Boiler Blowdown Pipings
 - 2.1 Disconnect blowdown piping downstream of the boiler blowdown valves. Connect air supply to surface or bottom blowdown piping.
 - 2.2 Blowdown piping to bilge drains. Use caution to prevent injury Co personnel or damage to equipment from air escaping from drain. Use minimum air pressure to verify piping is clean. Continue blowdown until discharge is visibly free of foreign matter.
 - 2.3 Shift air blowdown to other bloWdown piping connection. Blow air through to drain until discharge is visibly free of foreign matter.
 - 2.4 Blowdown piping overboard to verify hull valves are free of obstructions and debris. Take precautions to ensure no personnel are working in the area of the hull discharge whether ship is in dock or waterborne. Continue blowdown for a sufficient period of time to ensure piping is clean.
 - 2.5 If waterborne and discharge is below waterline on completion of blowdown, bleed off air pressure, shut hull valves, and crack open bilge drain. No leakage past hull valves should be observed.
 - 2.6 Upon completion of blowdown, restore system as necessary.
- 3.0 Anxiliary Boiler, Exhaust Gas Boiler Escape Steam, and Shore Steam Relief Valve Pipings
 - 3.1 Visually check escape steam and relief valve piping are free of obstructions and debris. If piping can not be determined to be clear, blowdown with air as described below.

SIZE	NASSCO DRAWING NUMBER	REV
A	445-342-7141	A
SCALE :	NONE	SHEET 40

- 3.2 Disconnect piping downstream of boiler safety valve or relief valve. Blow-out escape and relief piping from engine room to stack or from stack to engine room. Take precautions to ensure discharge of air does not injure personnel or damage equipment. Use minimum air pressure to verify piping is clear.
- 3.3 After auxiliary boiler and exhaust gas boiler escape steam and shore steam relief valve piping have been blown-out, restore systems as necessary.

SIZE	NASSCO DRAWING NUMBER	REV
A	445-342-7141	A
SCALE:	NONE	SHEET 41

FIREMAIN SYSTEM
445-342-7102

1.0 General:

- 1.1 Firemain system will be flushed using system pumps and strainers while waterborne.
- 1.2 Individual sections of firemain piping may be flushed using shore freshwater or salt water. Provisions should be made to prevent flushing of other firemain piping sections into previously cleaned sections.

2.0 Firemain Piping:

- 2.1 Clean fire pump suction strainer and suction ing. Line up fire-main system to flush from pump to discharges for fire plugs, anchor chain washdown, and shore connections. Connect hoses to firemain discharges and direct overboard clear of personel and equipment.
- 2.2 Flush system using fire pump by discharging overboard. Open a few discharges at a time working from pump discharge to end of various branches. Clean pump suction strainer as necessary.
- 2.3 Continue flushing until accessible discharges are visibly free of foreign matter.
- 2.4 Upon completion of flushing, clean system strainers and restore system as necessary.

SIZE	NASSCO DRAWING NUMBER	REV
A	445-342-7141	A
SCALE:	NONE	SHEET 42

SEA WATER COOLINGS SYSTEM

445-342-7109

- 1.0 General:
 - 1.1 Sea water supply to the central fresh water cooling system, main engine scavenge air coolers and bilge oily water separators, will be flushed using the system's pumps and strainers while waterborne.
 - 1.2 Individual sections of sea water cooling piping may be flushed using shore fresh water or salt water. Provisions should be made to prevent flushing of other sea water cooling piping sections into previously cleaned sections.
- 2.0 Sea Water Cooling Piping:
 - 2.1 Central fresh water cooler and main engine scavenge air coolers will be bypassed by installing hose jumpers.
 - 2.2 Clean sea water cooling pump suction piping. Line up sea water pumps and sea water cooling system to flush from pumps bypassing coolers to overboards. Pump suction will be from sea suction Compartment through sea inlet chests. Line up one pump and sea inlet chest at a time. Remove orifice in fresh water cooler outlet and scavenge air cooler outlet. Install hose at oily water separator piping inlet to overboard or to bilge. Remove oily water separator supply pressure regulating valve and strainers and install spool pieces.
 - 2.3 Flush system using one sea water cooling pump. Operate central fresh water cooler inlet valves to flush fresh water cooler piping and scavenge air cooler piping. Operate temperature regulating valve to flush overboard and through return line.
 - 2.4 Flush oily water separator piping overboard or to bilge. Continue flush until discharge is visibly free of foreign matter.
 - 2.5 When flush is complete, restore system by removing spool pieces and installing regulating valve, strainers and orifices. Remove hose jumpers from coolers and restore system as necessary.

SIZE	NASSCO DRAWING NUMBER	REV
A	445-342-7141	A

SCALE: NONE

SHEET 43

BALLAST AND HEELING SYSTEM
445-342-7116

- 1.0 General:
 - 1.1 Ballast system will be flushed using system pumps and eductors. Clean all ballast tanks. Clean tanks after all flushing operations are complete. Check that suction/discharge bellmouths are clear.

- 2.0 Fire/Ballast Pump Suction and Discharge Pipings:
 - 2.1 Clean suction piping from sea suction compartment. Align system and operate one fire/ballast pump to flush from sea suction compartment overboard through eductor and then through priming bottle. Repeat for other pump.

- 3.0 BallastTank piping:
 - 3.1 Partially fill forepeak ballast tank with sea water using fire/ballast pump to flush ballast piping into tank. Secure flush, dewater tank with portable pump, and clean tank.
 - 3.2 Partially fill one ballast tank in Hold No. 7 with fire/ballast pump. Secure flush, dewater tank using portable pump, and clean tank.

- 4.0 Heeling Pipings
 - 4.1 Visually inspect heeling piping to verify piping is free of foreign matter.

SIZE	NASSCO DRAWING NUMBER	REV
A	445-342-7141	A

SCALE: NONE SHEET 44

LOW TEMPERATURE FRESH WATER COOLING SYSTEM
445-342-7107

- 1.0 General;
- 1.1 All fresh water cooling piping will be flushed with fresh water.
- 1.2 Flushing will be conducted using installed service pumps and temporary strainers. Install hose jumpers to bypass all air conditioning units, condensers, coolers and air compressors during flushing.
- 2.0 Central Resh Water Cooling Piping:
- 2.1 Remove spool piece and install temporary strainer with muslin bag in pump suction piping.
- 2.2 Remove all control and regulating valves or devices which can trap sediment and install spool pieces.
- 2.3 Fill system with fresh water. Expansion tank in high temperature fresh water cooling system may be used. Line Up system to flush entire system or segments of system.
- 2.4 Continue flushing until temporary strainers and muslin bags are visibly free of foreign matter. During flushing blowdown installed strainer periodically to remove sediment. Flushing is not complete until all strainers, temporary and installed are visibly free of foreign matter. Operate regulating valve bypasses during flush to flush bypass piping.
- 2.5 Upon completion of flush, remove temporary strainers, hose jumpers, and spool pieces. Restore system as necessary.

SIZE	NASSCO DRAWING NUMBER	REV
A	445-342-7141	A
SCALE:	NONE	SHEET 45

HIGH TEMPERATURE FRESH WATER COOLING SYSTEM
445-342-7108

- 1.0 General:
 - 1.1 All fresh water cooling piping will be flushed with fresh water. Vent piping will be blown out with air.
 - 1.2 Flushing will be conducted using installed pumps and temporary strainers to protect pumps.
- 2.0 Jacket Water Vent Piping;
 - 2.1 Open expansion tank. Disconnect jacket water vent piping at SSDGS, de-aerating tanks and main engine jacket water de-aeration outlet.
 - 2.2 Blow-out each vent to expansion tank with air. Do not exceed 64 psig. Continue blow-out until discharge is visibly free of foreign matter.
- 3.0 Main Engine Fresh Water Cooling Piping:
 - 3.1 Remove spool piece and install temporary strainer with muslin bag in main engine fresh water cooling pump suction piping.
 - 3.2 Remove orifices and install blanks at main engine jacket water heater and distilling plant. Remove orifice and install spool piece at outlet of main engine. Remove check valve in heating water to main engine from SSDG'S and install spool piece.
 - 3.3 Install hose jumpers across main engine jacket water heater, main engine, and distilling plant. Remove high temperature regulating valve and install spool piece to direct flow back to pump suction.
 - 3.4 Fill expansion tank and system with clean fresh water. Line up system to flush from tank through pumps, bypassing main engine and distilling plant back to pump suction.
 - 3.5 Operate one fresh water cooling pump to flush system.
 - 3.6 Continue flushing until temporary strainer and muslin bag is visibly free of foreign matter. Include flow path through heating water return from main engine to SSDG8. Repeat flush using other pump.
 - 3.7 Line up main engine fresh water cooling pump to discharge through heating water to main engine from SSDGB piping back to pump suction.

SIZE	NASSCO DRAWING NUMBER	REV
A	445-342-7141	A
SCALE:	NONE	SHEET 46

- 3.8 Operate freshwater cooling pump to flush system. Continue flushing until temporary strainer and muslin bag is visibly free of foreign matter.
- 3.9 Hose jumpers, spool pieces, and blank flanges will remain in place until SSDG preheat circulating system is flushed.
- 4.0 SSDG Jacket Water and Preheat Circulating Piping:
- 4.1 Remove spool piece and install temporary Strainer with muslin bag in SSDG preheat circulating pump suction.
- 4.2 Install "Y" hose jumpers across SSDGS from high temperature water inlet and preheating water supply to high temperature water outlet. Remove constant flow fittings and install spool pieces.
- 4.3 Remove temperature regulating valve and install spool piece to direct flow to main engine high temperature fresh water cooling system. Remove check valves in SSDG high temperature water outlets and install spool pieces.
- 4.4 Line up one main engine fresh water cooling pump to flush to SSDG preheating piping and return via SSDG cooling water high temperature spill line. Flow path will also include cooling water to main engine. Regulate flow through main engine cooling to avoid excessive flow through SSDG preheating piping.
- 4.5- Continue flushing until temporary strainer in main engine fresh water cooling pump suction piping is visibly free of foreign matter.
- 4.6 Line up one main engine fresh water cooling pump to flush through main engine cooling water piping to SSDG cooling water high temperature spill to SSDG high temperature jacket water piping and returning to the pump suction through the SSDG cooling water make up. Blank vent in de-aerating tank for SSDGS if necessary.
- 4.7 Operate the fresh water cooling pump and continue flushing until the temporary strainer in the pump suction is visibly free of foreign matter.
- 4.8 Upon completion of flush, line up one SSDG preheat circulating pump to flush SSDG preheating piping.
- 4.9 Continue flushing until temporary strainer in SSDG preheat circulating pumps is visibly free of foreign matter. Repeat flush for other pump.
- 4.10 Upon completion of flush, remove hose jumpers, temporary strainers, and blanks. Restore system as necessary.

SIZE	NASSCO DRAWING NUMBER	REV
A	445-342-7141	A
SCALE:	NONE	SHEET 47

DISTILLING PLANT SERVICES
445-342-7126

- 1.0 General:
 - 1.1 Feed and brine overboard piping will be flushed using ejector pump from sea suction compartment. Distillate piping to potable water tanks will be flushed with fresh water. Distillate piping to potable water tanks will be chlorinated with the potable water system.
 - 1.2 Ejector pump suction piping to sea suction compartment will be checked prior to final connection to verify no debris is left in piping.

- 2.0 Feed and Brine Overboard Piping:
 - 2.1 Install hose jumper to bypass distilling plant from seawater inlet to overboard piping connection.
 - 2.2 Line up system to take suction from sea suction compartment and discharge overboard. Check that area near overboard discharge is clear of personnel and equipment.
 - 2.3 Flush system using ejector pump for 30 minutes or until discharge, if visible, is clear.
 - 2.4 After completion of flushing remove hose jumpers and restore system as necessary.

- 3.0 Distillate Piping:
 - 3.1 Open and clean potable water and distilled water tanks. Disconnect distillate piping at distillate outlet and connect fresh water supply
 - 3.2 Flush piping to each tank with fresh water until discharge is visibly free of foreign matter.
 - 3.3 Upon completion of flush, dewater tanks, clean and install covers. Remove fresh water hose.

SIZE	NASSCO DRAWING NUMBER	REV
A	445-342-7141	
SCALE:	NONE	SHEET 48

POTABLE WATER SYSTEM
445-331-4503

- 1.0 General:
- 1.1 All potable water tanks, piping, fixtures, and pumps for stowage or use of potable water will be disinfected.
- 1.2 Disinfection will be done after all work on the potable water system is complete. After disinfection the potable water tanks and system will not be opened. If necessary to reopen potable water tanks or the potable water system, disinfection will be repeated.

- 2.0 Potable Water Piping:
- 2.1 If not already accomplished open and clean potable water tanks by hand.
- 2.2 Fill the potable water tank and piping with potable water from dock-side. Fill system using all deck connections.
- 2.3 Flush potable water system by operating system pumps and flushing through to each outlet. Flush until discharges are visibly free of foreign matter.
- 2.4 After flushing has been completed, refill system including distillate piping to potable water tanks and chlorinate for a concentration of 50 ppm. Operate system pumps and circulate chlorinated water throughout system. Operate outlets nearest the storage tanks to obtain chlorinated water at each fixture or opening. Continue the process outward from the tanks until all fixtures and openings have been flushed with chlorinated water. Refill the potable water tanks and dechlorinate as necessary to maintain the 50 ppm concentration.
- 2.5 Fill system and tanks to overflowing with 50 ppm chlorinated water and allow system to stand filled for four hours.
- 2.6 After four hours, drain and flush system with potable water until the chlorine taste at fixtures and openings is not objectionable.

SIZE	NASSCO DRAWING NUMBER	REV
A	445-342-7141	A

SHIP SERVICE SYSTEM
445-342-7118

- 1.0 General:
- 1.1 Service air piping will be flushed using air from the ship service air compressor, starting air compressors or shore air at 125 PSIG maximum reduced pressure.
- 2.0 Ship Service Air:
 - 1.1 Compressor/Receiver Piping:
 - 2.1.1 Operate compressor to supply air to ship service air system or connect air hose to compressor outlet. Air pressure should be approximately 125 psig.
 - 2.1.2 Blowdown drains in piping and receiver until the discharge is visibly free of foreign matter.
 - 2.1.3 Upon completion of blow-out, clean air receiver strainer and restore system as necessary.
 - 2.2 Second Deck and Main Deck Outlets:
 - 2.2.1 Remove filter/separators at hose connection. Operate compressor or use air hose connected to system piping to blow-out each air connection. Start at engine room and blow-out through each air connection and drain in ship service air mains.
 - 2.2.2 Continue each air connection blow-out until the discharge is visibly free of foreign matter. Blow-out each connection and drain on the second, main, and forecastle deck.
 - 2.2.3 For the chemical bilge pump, disconnect air supply to pump and blow-out until the discharge is visibly free of foreign matter.
 - 2.2.4 Upon completion of blow-out clean and install filter/separator.
 - 2.3 Machinery Space Ship Service Air:
 - 2.3.1 Remove filter/separator at hose connections. Operate compressor or use air hose connected to system piping to blow-out each air connection. Start at compressor connection to Vertical supply main and blow-out each air connection and pump supply.

SIZE	NASSCO DRAWING NUMBER	REV
A	445-342-7141	A
SCALE:	NONE	SHEET 50

- 2.3.2 Continue each air connection blow-out until the discharge is visibly free of foreign matter. Blow-out each air connection at each level.
- 2.3.3 For the lube oil transfer pump and sludge transfer pump, disconnect the air supply to the pump and blow-out until the discharge is visibly free of foreign matter.
- 2.3.4 Upon completion of blow-out, clean and install filter/separators.

SIZE	NASSCO DRAWING NUMBER	REV
A	445-342-7141	A
SCALE:	NONE	SHEET 51

STARTING AIR SYSTEM
445-342-7112

- 1.0 General:
- 1.1 Starting air piping will be flushed using air from the starting air compressors, emergency starting air compressor or shore air.
- 2.0 starting Air Piping
- 2.1 Diesel Generator Starting and Control Air Piping:
 - 2.1.1 Disconnect starting air and control air piping at diesel generators. Blow-out piping using air compressors or shore air. Do not exceed 435 psi. Use caution when blowing down oil and water separators, air tank, and diesel generator piping.
 - 2.1.2 Continue blow-out until discharges are visibly free of foreign matter.
 - 2.1.3 Upon completion of blow-out, clean air tank strainer and restore system as necessary.
- 2.2 Main Engine Starting, Control, and Safety Air Piping:
 - 2.2.1 Remove filters to main engine control and safety air. Remove strainers for fuel valve testing and emergency ships service air supply. Install temporary piping or hoses to direct discharge of air to bilge or deck.
 - 2.2.2 Operate compressors or use shore air hose to flush piping in sequence from compressor to separator, air tanks, and temporary piping or hoses at main engine control and safety air filters, fuel valve testing and Ships service air strainers.
 - 2.2.3 Continue flushing until discharges are visibly free of foreign matter.
 - 2.2.4 Upon completion of blow-out, if ship's service air is not to be flushed, reinstall strainer for ship's service air.
- 2.3 main Engine Control and Safety Air Piping:

SIZE	NASSCO DRAWING NUMBER	REV
A	445-342-7141	A
SCALE:	NONE	SHEET 52

CONTROL AIR SYSTEM
445-342-7119

- 1.0 General
- 1.1 Control air piping will be flushed using air from the starting air compressors emergency starting air compressor, ships service air compressor Or shore air at 125 PSIG maximum reduced pressure.
- 2.0 control Air Piping
- 2.1 Install jumper hose to bypass dehydrator. Disconnect control air piping at each component served. Remove in-line filters and strainers.
- 2.2 Using air from compressors or clean, dry, oil free shore air, blowdown receivers and control piping working from receivers outward.
- 2.3 Continue blow-out until discharges are visibly free of foreign matter.
- 2.4 Upon completion of blow-out, clean and install filters and strainers, restore systems as necessary.

SIZE	NASSCO DRAWING	REV
A	445-342-7141	A
SCALE:	NONE	SHEET 54

HYDRAULIC PIPING SYSTEM
445-342-7128

- 1.0 General:
- 1.1 Where vendor supplied components are not shipped charged with appropriate fluids they must be flushed and inspected prior to charging by vendor and verified by NASSCO Q.A.
- 1.2 All hydraulic fluid added to the system must be filtered through a 3 to 10 micron filter. Good housekeeping procedures must be followed to minimize all potential contamination problems in transferring fluid from the shipping containers to hydraulic reservoir.
- 1.3 This procedure flushes shipbuilder installed piping only for hydraulic systems for deck machinery, water tight door, elevator, bow thruster and steering gear.
- 1.4 The system shall be periodically vented to bleed out air and insure that pipe intervals are full of fluid.
- 2.0 Hydralalic Piping
- 2.1 Install temporary flushing pump, filters and hose jumpers to flush shipbuilder installed piping. Bypass or remove and install spool pieces for all hydraulic pumps, motors, complex valves and devices that restrict flow.
- 2.2 System hydraulic oil shall be used for flushing.
- 2.3 Line up the system to flush the hydraulic piping and fill the system with hydraulic oil.
- 2.4 Operate the temporary flushing pump to flush the hydraulic piping.
- 2.s During circulation, the system piping, particularly in the area of welded joints, shall be vibrated periodically with vibrators, wooden mallets or other equivalent means.
- 2.6 Clean filter elements shall be installed l s necessary to keep the pressure drop across the filter within the specified limits.
- 2.7 Switch the supply and return hoses from the temporary flushing unit at least-once, thus reversing the flow in the pipe runs.

SIZE	NASSCO DRAWING NUMBER	REV
A	445-342-7141	A
SCALE:	NONE	SHEET 55

- 2.8 When the filter elements are free of foreign matter, obtain a representative oil sample and send to a laboratory for a particulate count. The sample shall meet the cleanliness standard of SAE, Class 5. Repeat flushing procedure until cleanliness standard is met.
- 2.9 After flushing has been completed, remove the temporary flushing unit, blank flanges, hose jumpers, hose connections, and clean all openings. Restore the system as necessary.

SIZE	NASSCO DRAWING NUMBER	REV
A	445-342-7141	A
SCALE:	NONE	SHEET 56

DECK DRAINS AND MISCELLANEOUS DRAINS SYSTEMS
445-342-7101

- 1.0 Deck Drains and Miscellaneous Drains
- 1.1 Blow out drains with air or flush with Water to verify drains are open.

SIZE	NASSCO DRAWING NUMBER	REV
A	445-342-7141	A
SCALE:	NONE	SHEET 57

CO²SYSTEM

445-342-7103

- 1.0 Generals
 - 1.1 CO2 piping will be blown out with clean filtered air prior to connecting CO2 bottles, manifolds, distribution piping and main engine scavenge air CO² piping.
- 2.0 Control Piping:
 - 2.1 Blow-out cylinder control piping with air prior to connecting cylinders to control piping. Blow-out from manifold to cylinder connection.
 - 2.2 Continue blow-out until each control line is visibly free of foreign matter.
- 3.0 Discharge Manifold Piping:
 - 3.1 Blow-out cylinder discharge manifold piping prior to connecting cylinders to discharge manifold. Blow-out from manifold to cylinder connection.
 - 3.2 Continue blow-out until each discharge connection is visibly free of foreign matter.
- 4.0 Distribution Piping:
 - 4.1 Connect air supply to manifold outlet. Line up CO2 system to blow-out individual piping lines to engine room and each hold.
 - 4.2 Continue blow-out for each section until discharges are visibly free of free of foreign matter. Clean dirt traps. Check all outlets to verify nozzles are clear.
- 5.0 Main Enginw Scavenge Air CO2 Pipings
 - 5.1 Blow-out main engine scavenge air c02 piping as described in Paragraphs 3.0 and 4.0 up co main engine connection.

SIZE	NASSCO DRAWING NUMBER	REV
A	445-342-7141	A
SCALE:	NONE	SHEET 58

BILGE SYSTEM
445-342-7110

- 1.0 General:
- 1.1 Sections of bilge piping will be flushed by filling bilge pockets with water and removing by use of an eductor or installed pumps.
- 1.2 Prior to flushing piping ensure bilge areas are clean. Clean bilge pockets, bilge wells, anti plate and rosebud strainers.
- 2.0 Bilge Housekeeping
- 2.1 Line up bilge housekeeping pump to take suction on sea suction compartment and discharge overboard via deck shore connection or use hose jumper to bypass bilge separator unit and discharge overboard.
- 2.2 Flush bilge housekeeping pump suction piping until pump suction strainer remains visibly free of foreign matter.
- 2.3 Secure flush and line up bilge housekeeping pump to take suction on bow thruster compartment bilge well.
- 2.4 Fill bilge well in bow thruster compartment using forward void bilge eductor or hose. Take suction on this bilge well using the bilge housekeeping pump and discharging overboard. Operate eductor or hose to maintain water level in bilge well.
- 2.5 Continue flush until pump suction strainer is visibly free of foreign matter.
- 2.6 After flush is complete, line up system to flush oily water separator piping to the overboard hull discharge if this was not done previously. Install hose jumpers across oily water separator and oil content monitor as necessary.
- 2.7 Flush overboard piping through overboard hull discharge.
- 2.8 After flush is complete, remove hose jumpers, restore system and clean all strainers.

SIZE	NASSCO DRAWING NUMBER	REV
A	445-342-7141	
SCALE:	NONE	SHEET 59

- 3.0 Main Biige piping:
- 3.1 Line up main bilge pump to take suction on sea suction compartment and discharge overboard.
- 3.2 Flush piping using main bilge pump until-pump suction strainer is visibly free of foreign matter.

SIZE	NASSCO DRAWING NUMBER	REV
A	445-342-7141	A
SCALE:	NONE	SHEET 60

DIESEL ENGINES AND AUXILLIARY BOILER EXHAUST SYSTEM
445-342-7117

- 1.0 Diesel Engines and Anxiliaxy Boiler Exhaust Piping:
- 1.1 The diesel engine and auxiliary boiler exhaust system will be visually inspected for cleanliness prior to final connection of piping and ducting. Clean as necessary.

SIZE	NASSCO DRAWING NUMBER	REV
A	445-342-7141	A
SCALE: NONE		SHEET 61

VENTS, SOUNDING TUBES AND OVERFLOW SYSTEM
M5-342-7122

- 1.0 Vents, sounding Tubes, and Overflow Piping:
- 1.1 Blow-out vents, sounding tubes, and overflow with clean dry air.
Use minimum pressure to prevent piping damage.

SIZE	NASSCO DRAWING NUMBER	REV
A	445-342-7141	A
SCALE:	NONE	SHEET 62

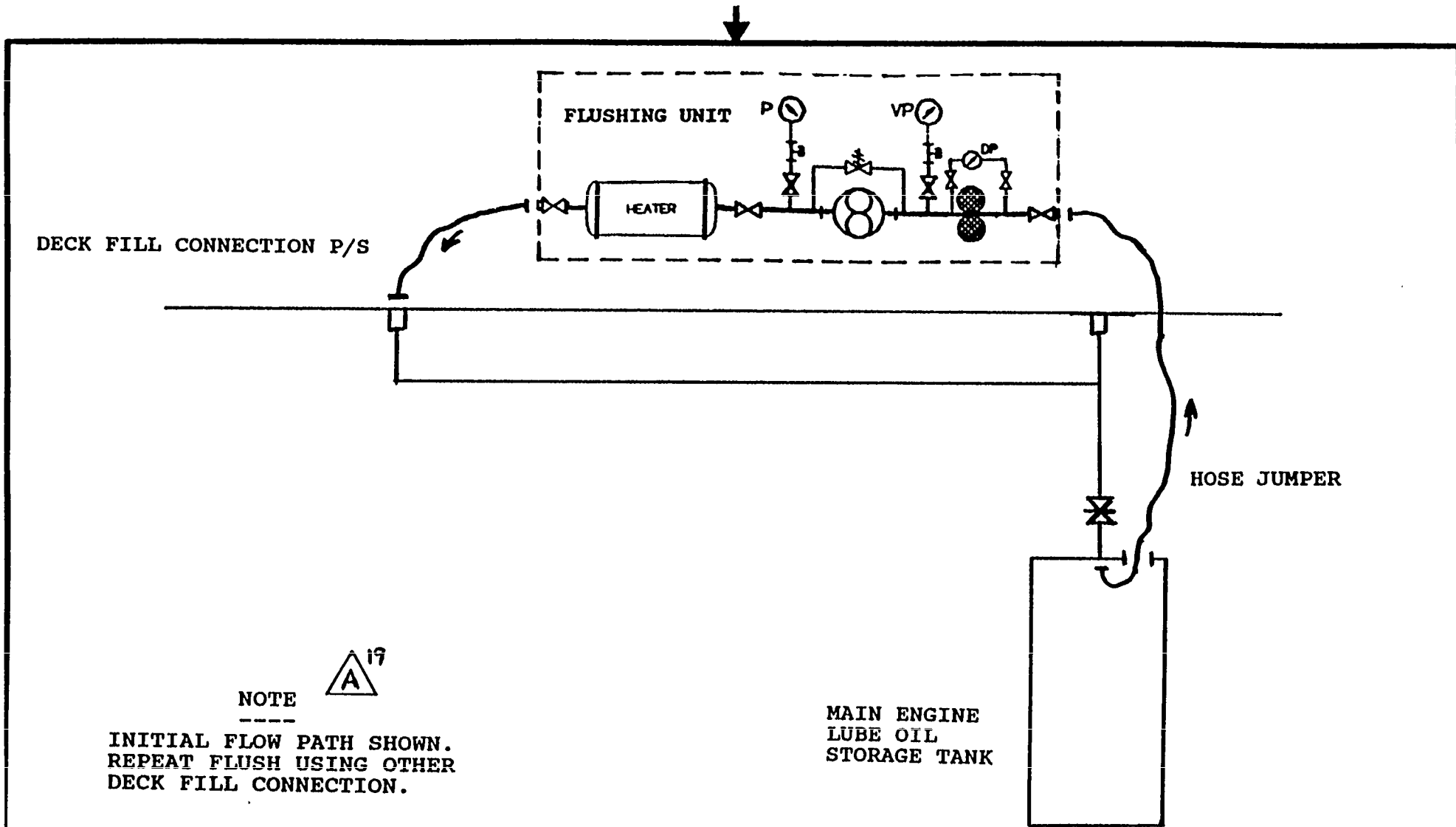

NOTE 

 INITIAL FLOW PATH SHOWN.
 REPEAT FLUSH USING OTHER
 DECK FILL CONNECTION.

MAIN ENGINE
 LUBE OIL
 STORAGE TANK

ENCLOSURE 1

FLUSHING OF DECK FILLING PIPING TO
 MAIN ENGINE LUBE OIL STORAGE TANK

SIZE	NASSCO DRAWING NUMBER	REV
A	445-342-7141	A
SCALE:	NONE	SHEET 63

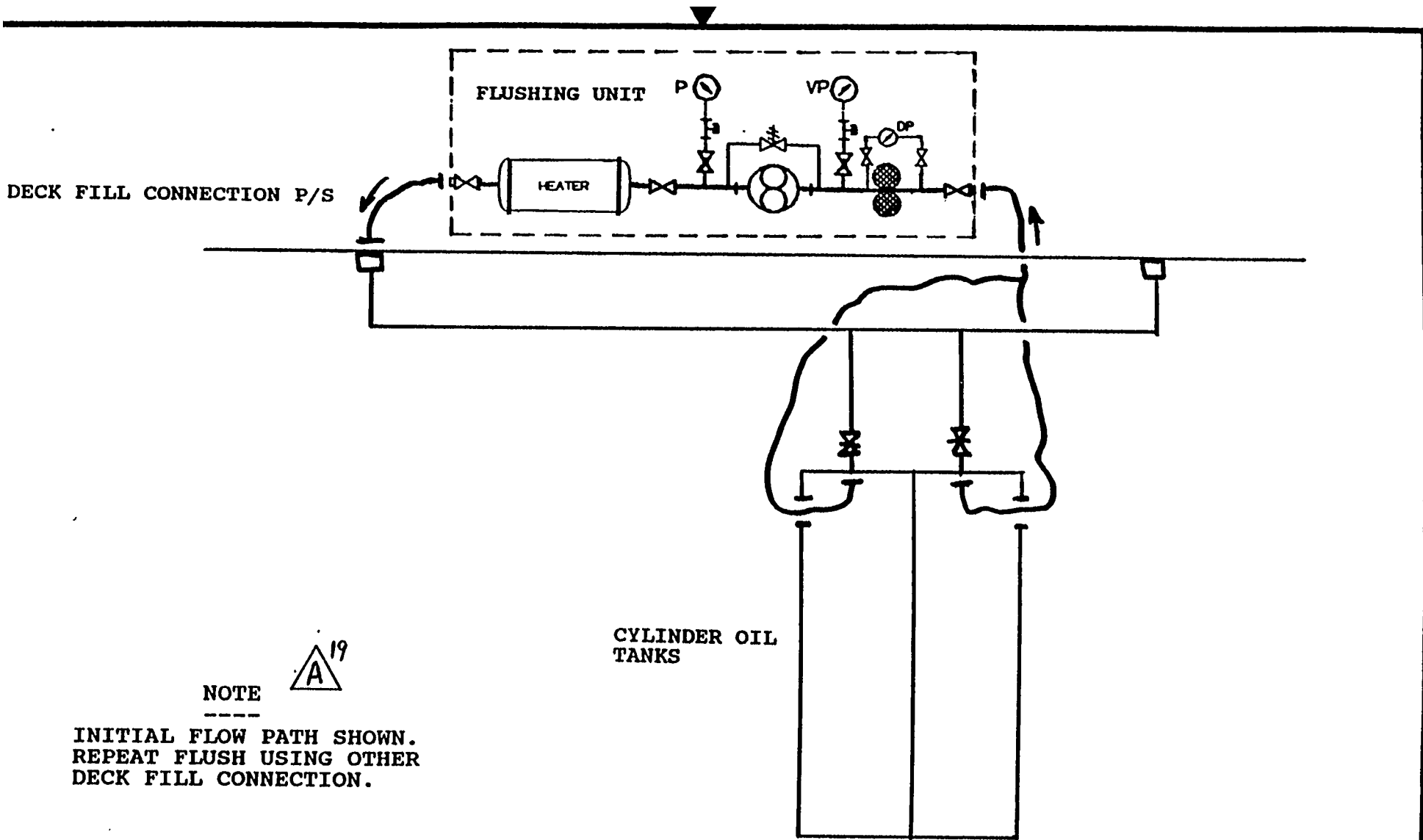

ENCLOSURE 2

FLUSHING OF DECK FILLING PIPING
TO CYLINDER OIL STORAGE TANKS

SIZE	NASSCO DRAWING NUMBER	REV
A	445-342-7141	A
SCALE:	NONE	SHEET 64

**FLUSHING OF MAIN ENGINE LUBE OIL STORAGE TANK AND
RENOVATING TANK OVERFLOW AND LUBE OIL SUMP FILL**

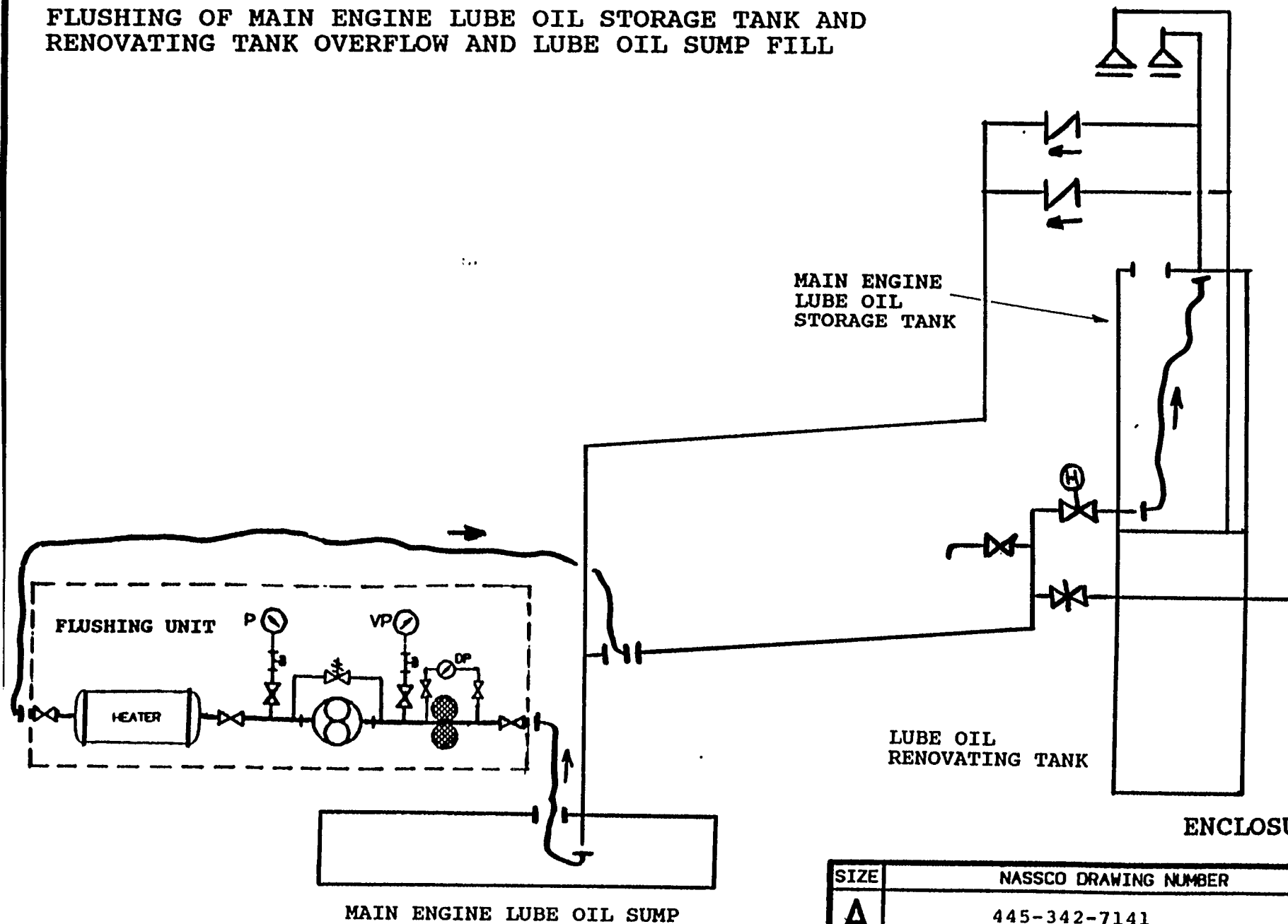

ENCLOSURE 3

SIZE	NASSCO DRAWING NUMBER	REV
A	445-342-7141	A
SCALE:	NONE	SHEET 65

FLUSHING OF MAIN ENGINE LUBE OIL STORAGE TANK AND
 RENOVATING TANK OVERFLOW AND LUBE OIL SUMP FILL

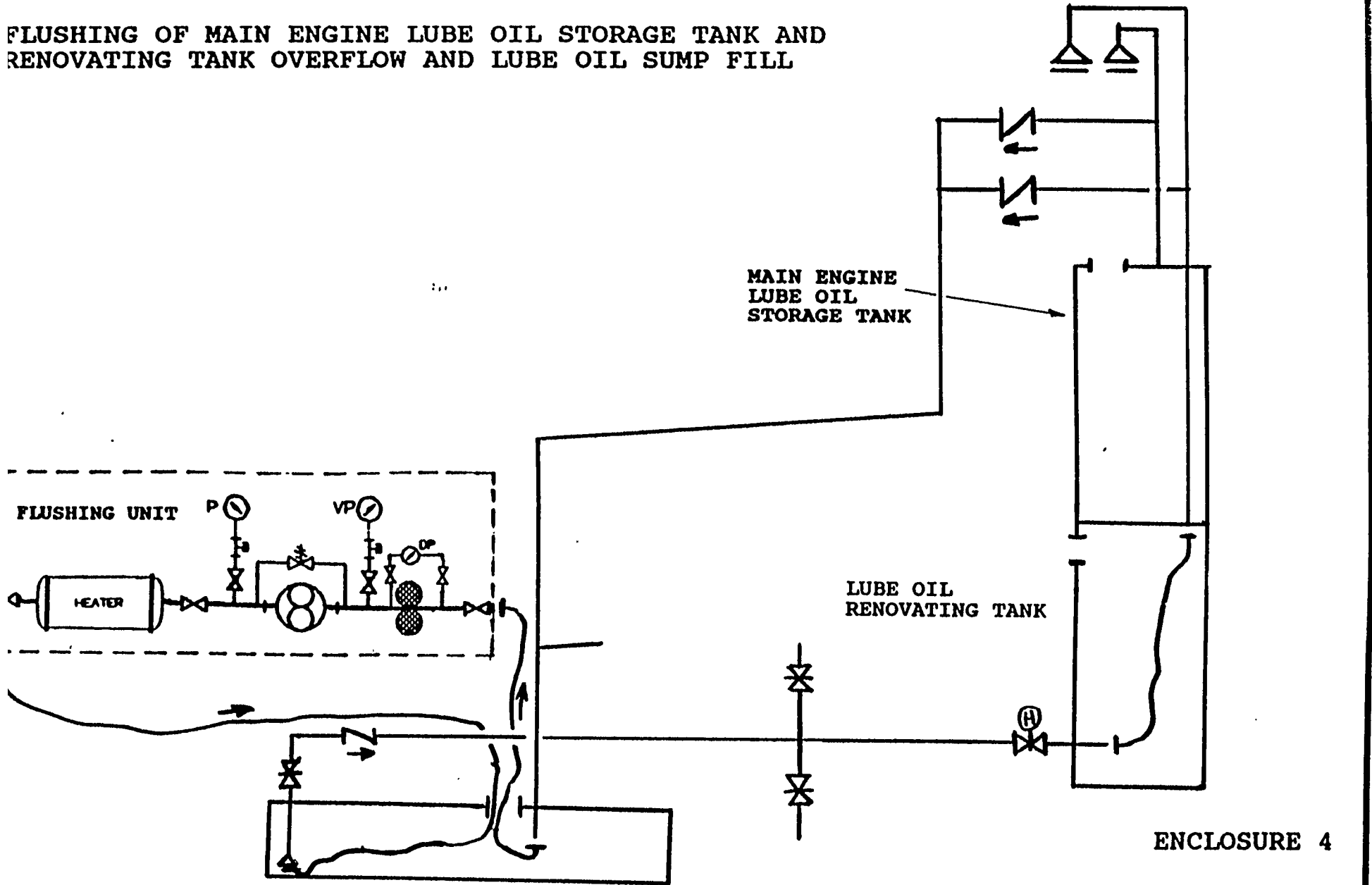

ENCLOSURE 4

SIZE	NASSCO DRAWING NUMBER	REV
A	445-342-7141	A
SCALE:	NONE	SHEET 66

A 19

NOTE

INITIAL FLOW PATH SHOWN.
REPEAT FLUSH FOR OTHER
DIESEL GENERATORS.

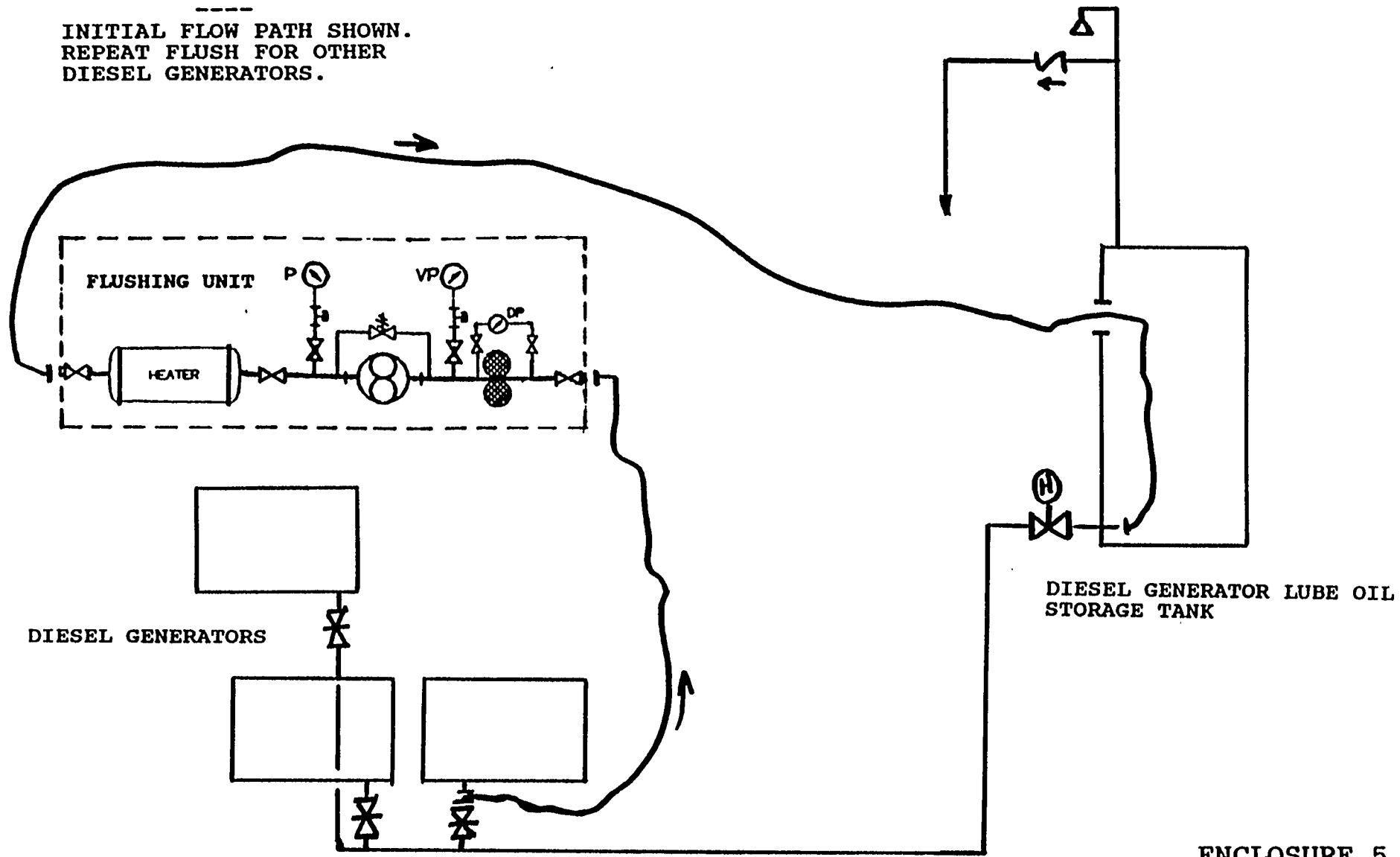

ENCLOSURE 5

**FLUSHING OF DIESEL GENERATOR
LUBE OIL SUPPLY PIPING**

SIZE	NASSCO DRAWING NUMBER	REV
A	445-342-7141	A
SCALE:	NONE	SHEET 67

↓
A¹⁹

NOTE

INITIAL FLOW PATH SHOWN. REPEAT FLUSH FOR
OTHER TRANSFER PUMP AND CYLINDER OIL TANK.

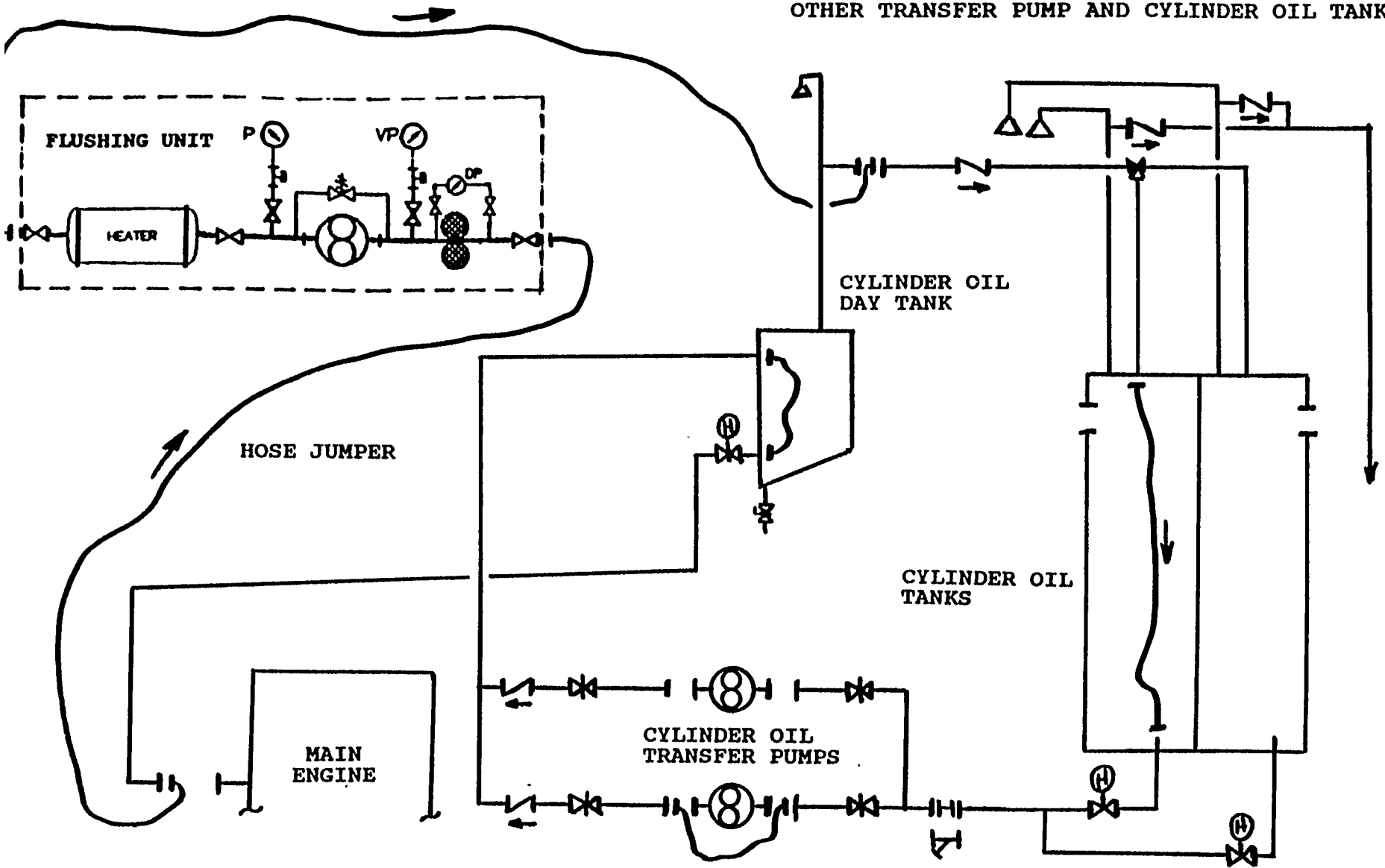

FLUSHING OF CYLINDER OIL
TRANSFER AND SERVICE PIPING

ENCLOSURE 6

SIZE	NASSCO DRAWING NUMBER	REV
A	445-342-7141	A
SCALE:	NONE	SHEET 68

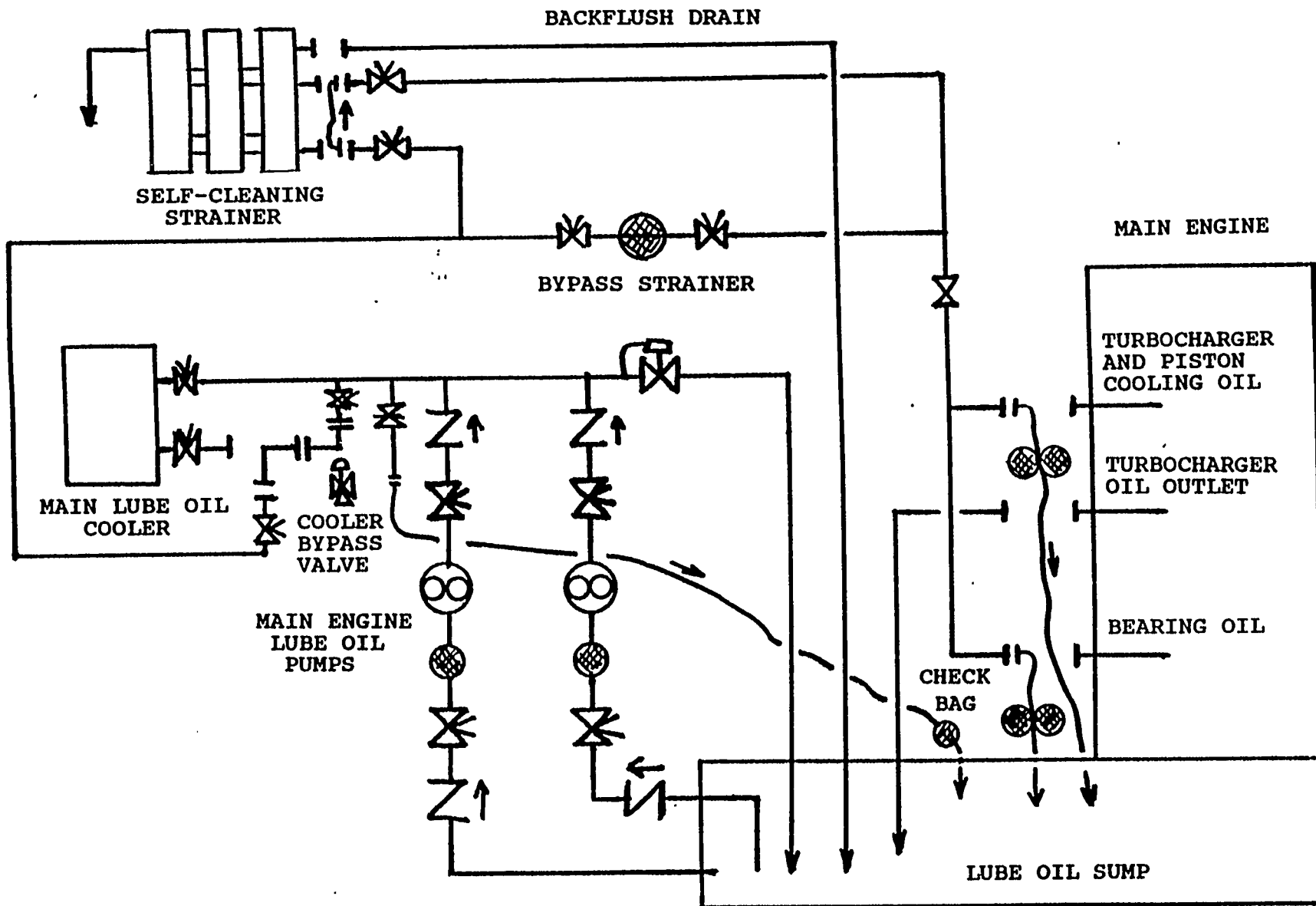

**FLUSHING OF MAIN ENGINE
LUBE OIL BYPASSING COMPONENTS**

ENCLOSURE 7

SIZE	NASSCO DRAWING NUMBER	REV
A	445-342-7141	A
SCALE:	NONE	SHEET 69

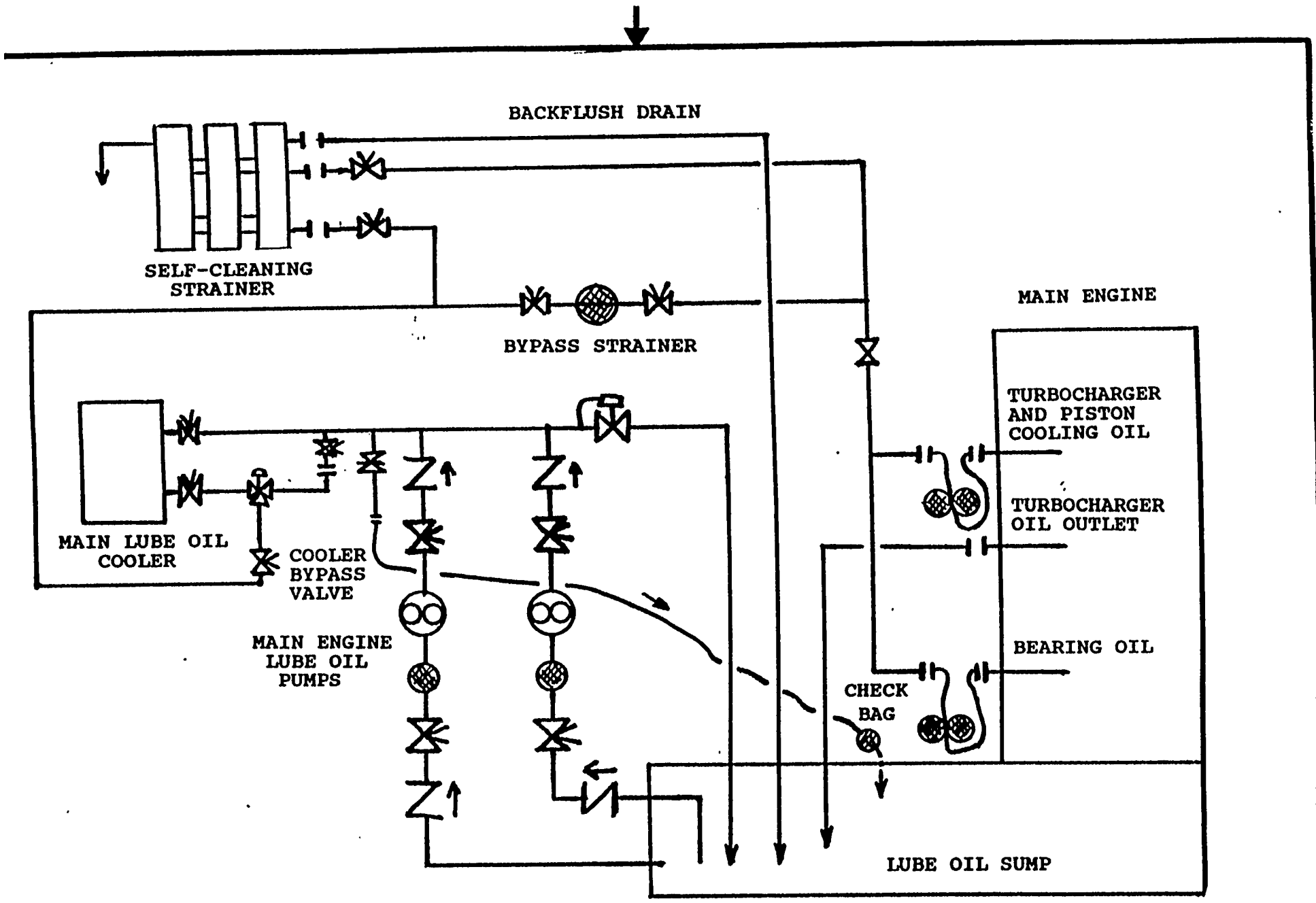

FLUSHING OF MAIN ENGINE
LUBE OIL INCLUDING COMPONENTS

ENCLOSURE 8

SIZE	NASSCO DRAWING NUMBER	REV
A	445-342-7141	A
SCALE:	NONE	SHEET 70

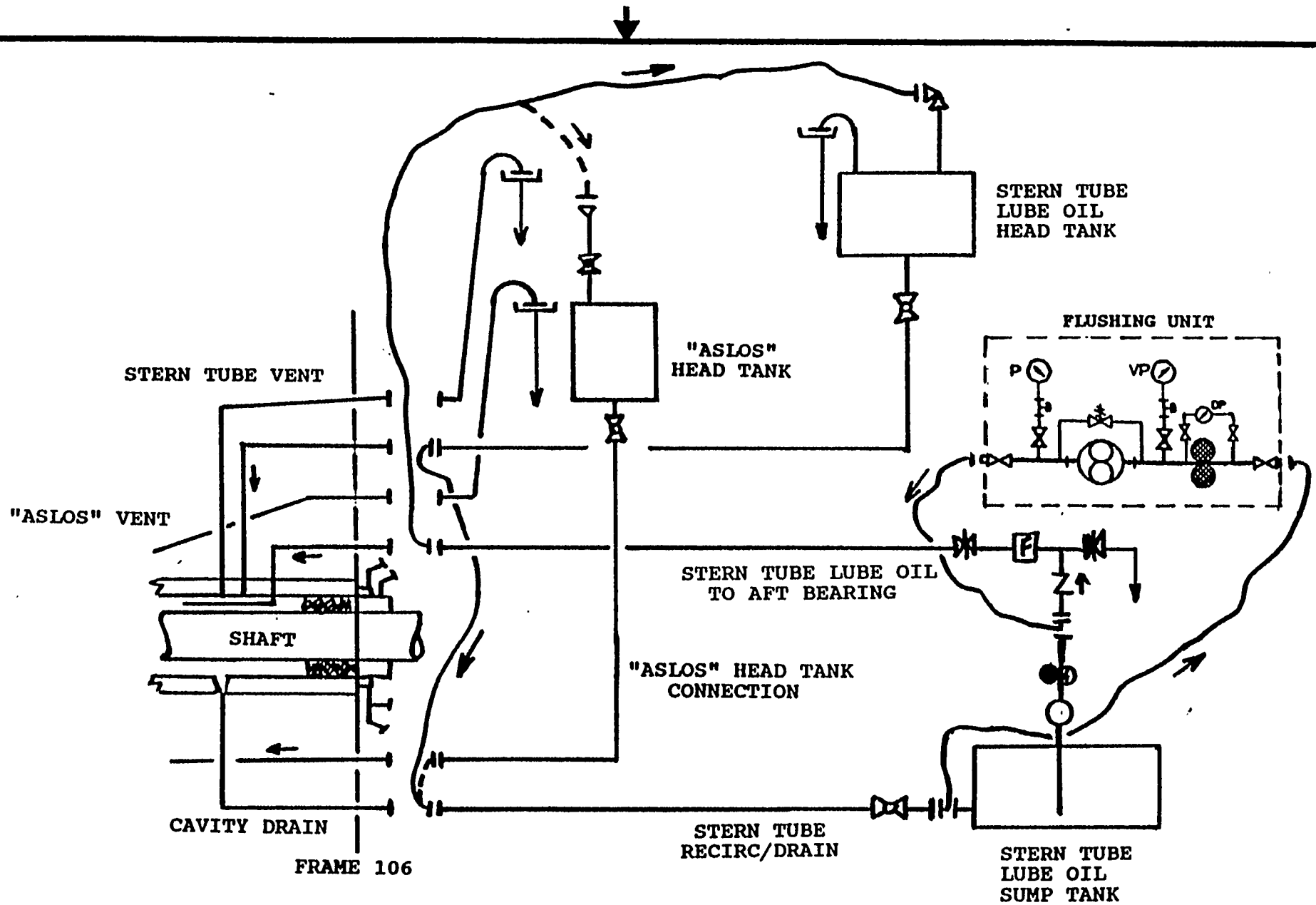

**FLUSHING OF STERN TUBE
LUBE OIL PIPING**

ENCLOSURE 9

SIZE	NASSCO DRAWING NUMBER	REV
A	445-342-7141	A
SCALE:	NONE	SHEET 71

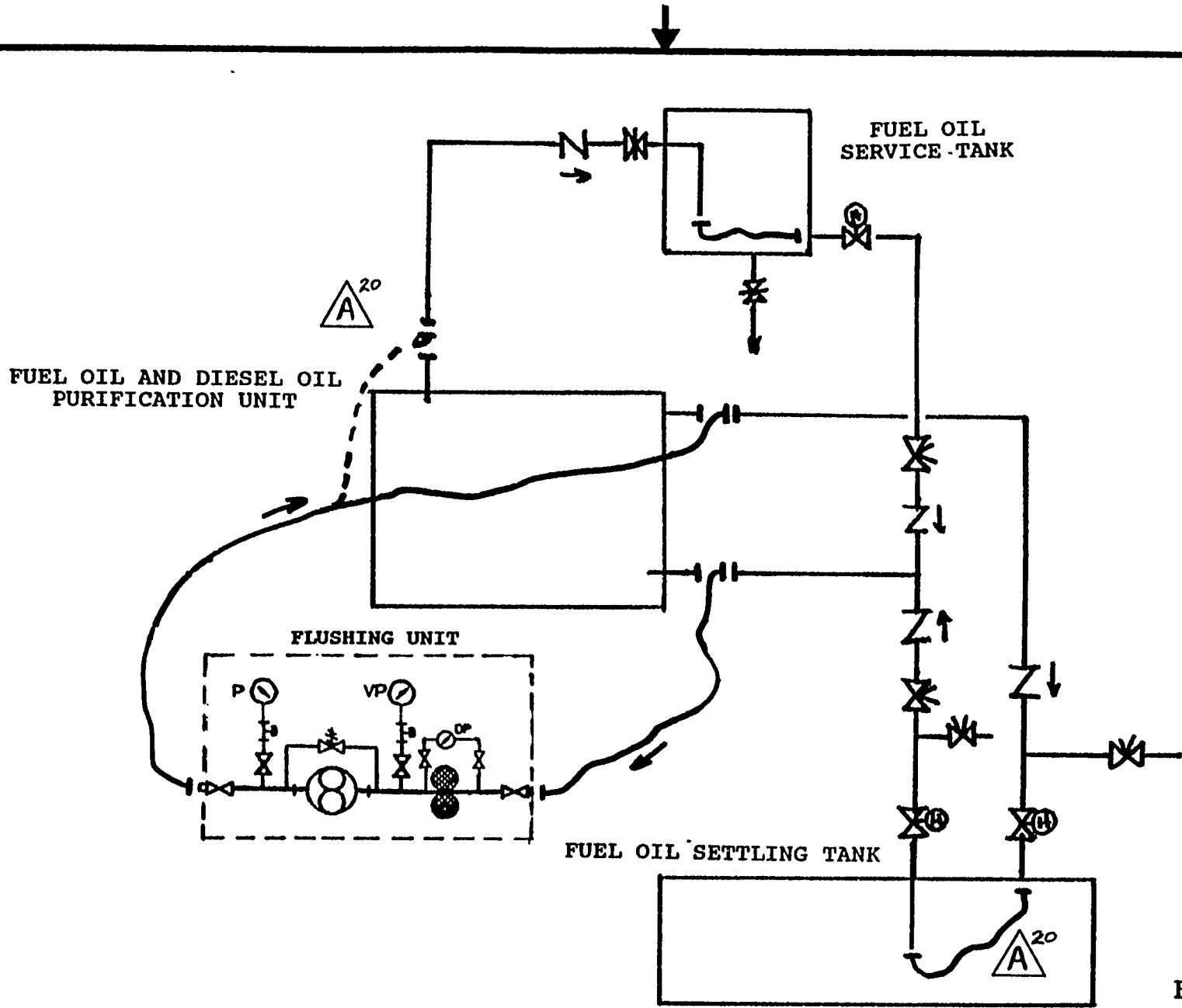

ENCLOSURE 10

**FLUSHING OF FUEL OIL
PURIFICATION PIPING**

SIZE	NASSCO DRAWING NUMBER	REV
A	445-342-7141	A
SCALE:	NONE	SHEET 72

A¹⁹

NOTE

INITIAL FLOW PATH SHOWN.
REPEAT FLUSH FOR OTHER
DIESEL OIL STORAGE TANK.

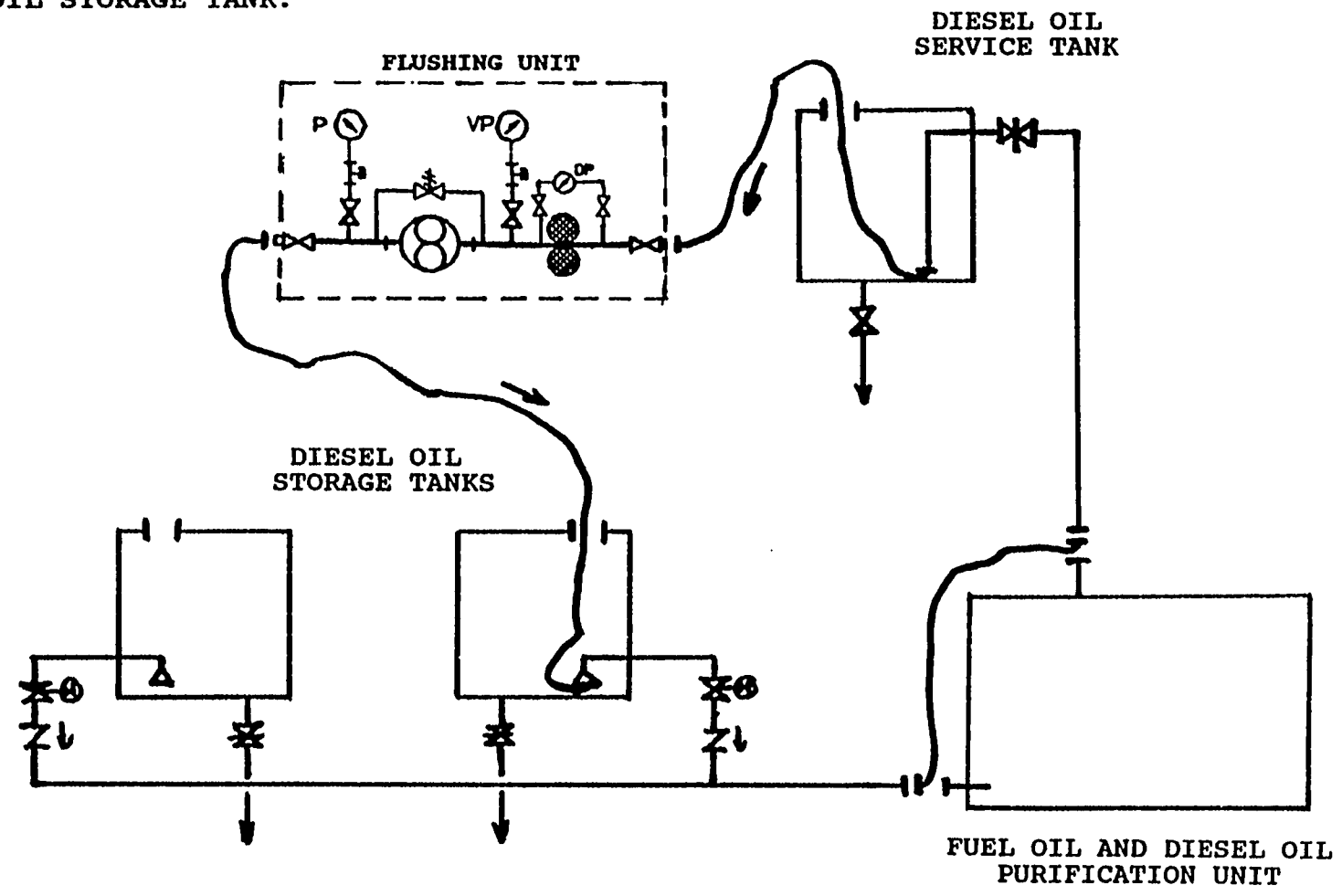

ENCLOSURE 11

FLUSHING OF DIESEL OIL
PURIFICATION PIPING

SIZE	NASSCO DRAWING NUMBER	REV
A	445-342-7141	A
SCALE:	NONE	SHEET 73

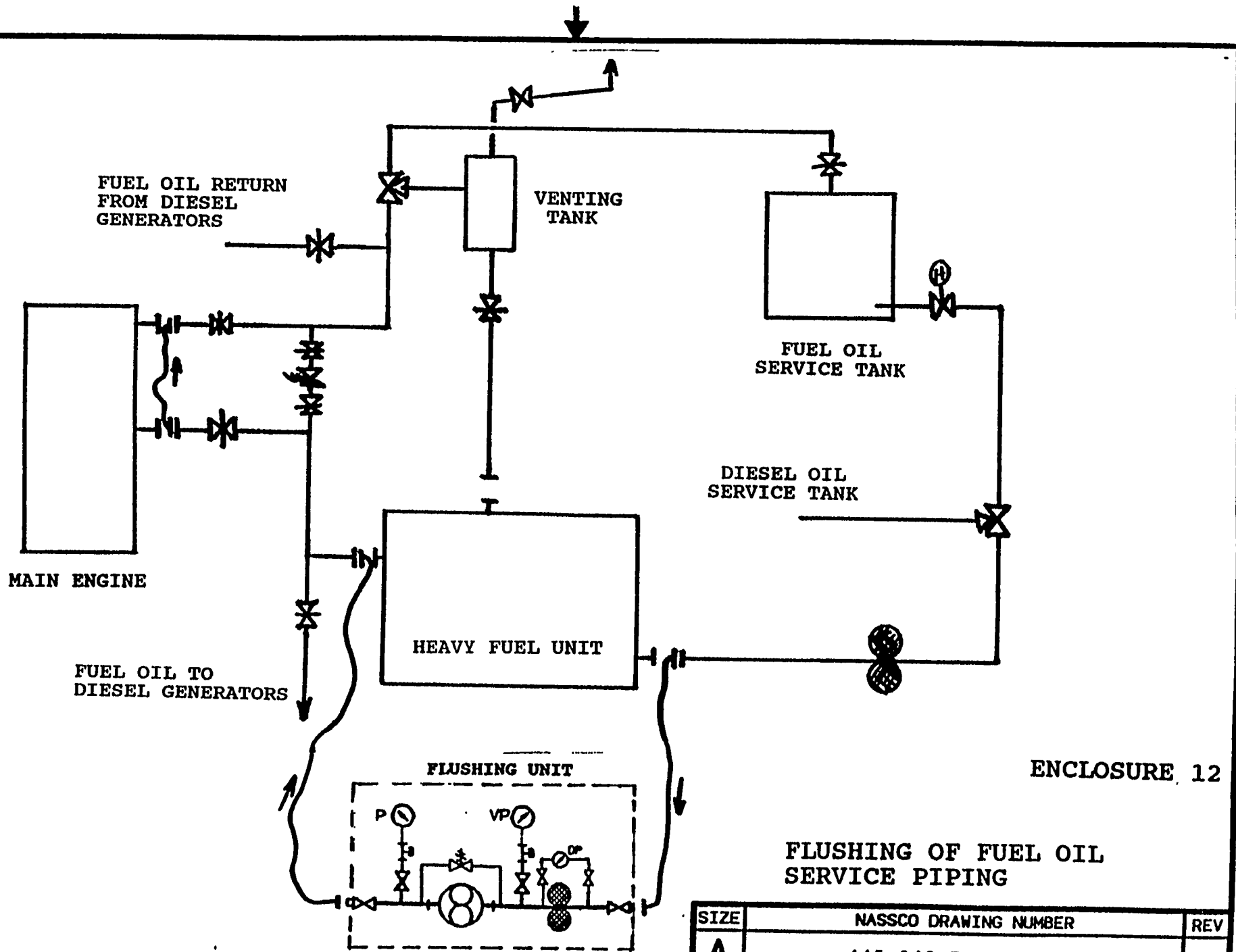

SIZE	NASSCO DRAWING NUMBER	REV
A	445-342-7141	A
SCALE:	NONE	SHEET 74

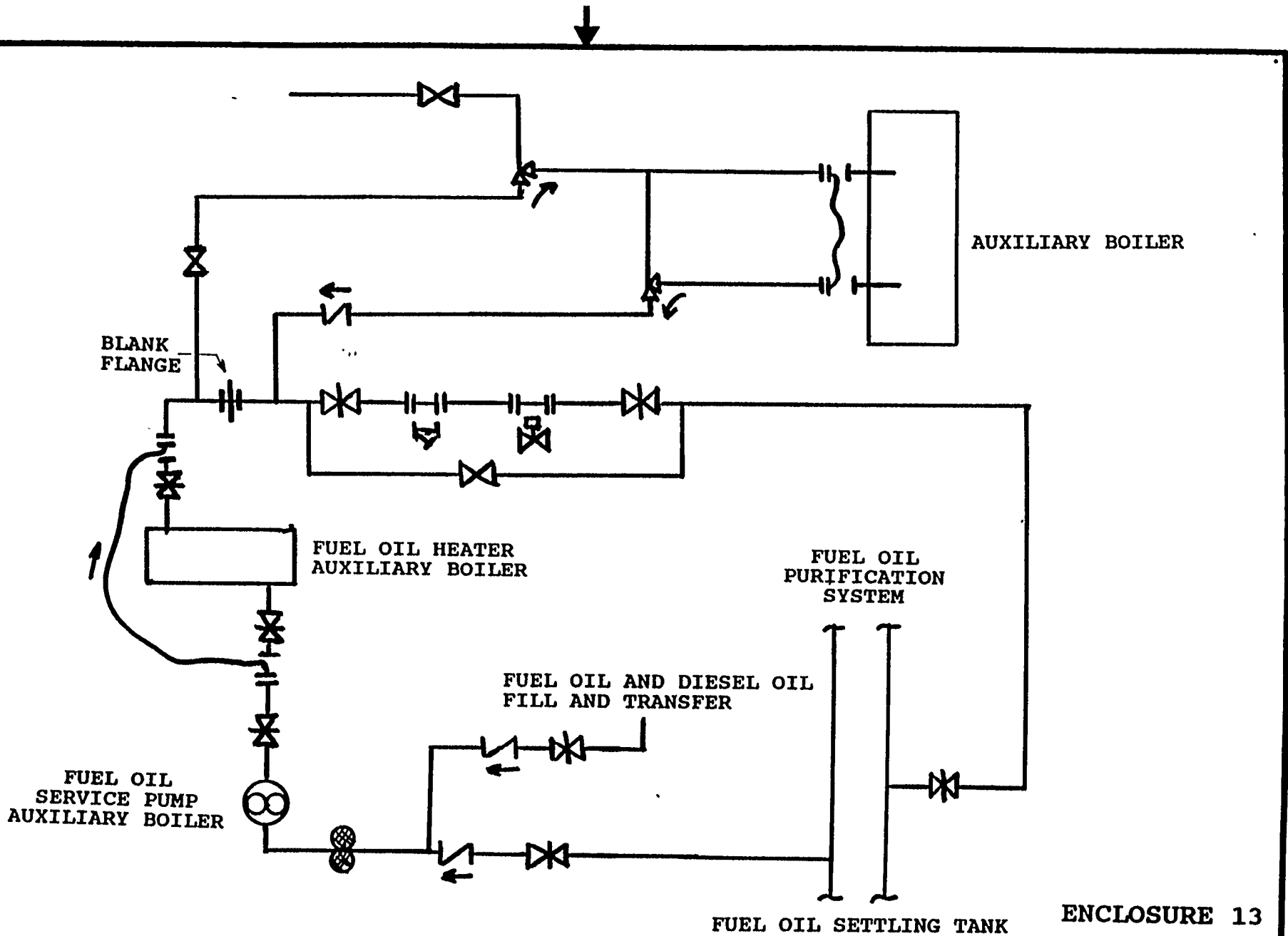

**FLUSHING OF AUXILIARY BOILER
FUEL OIL SERVICE PIPING**

SIZE	NASSCO DRAWING NUMBER	REV
A	445-342-7141	A
SCALE:	NONE	SHEET 75

ENCLOSURE 13

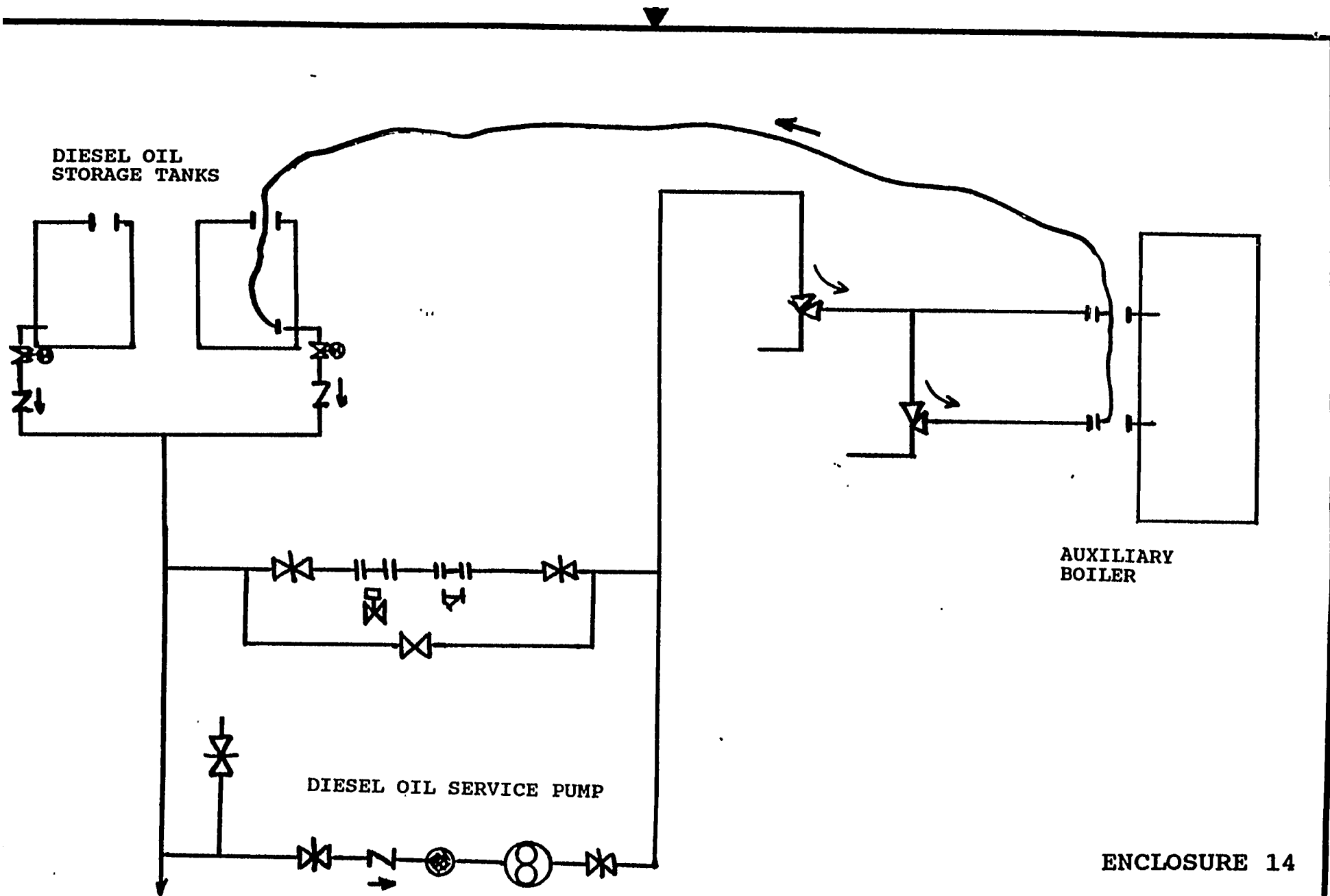

FLUSHING OF AUXILIARY BOILER
DIESEL OIL SERVICE PIPING

ENCLOSURE 14

SIZE	NASSCO DRAWING NUMBER	REV
A	445-342-7141	A
SCALE:	NONE	SHEET 76

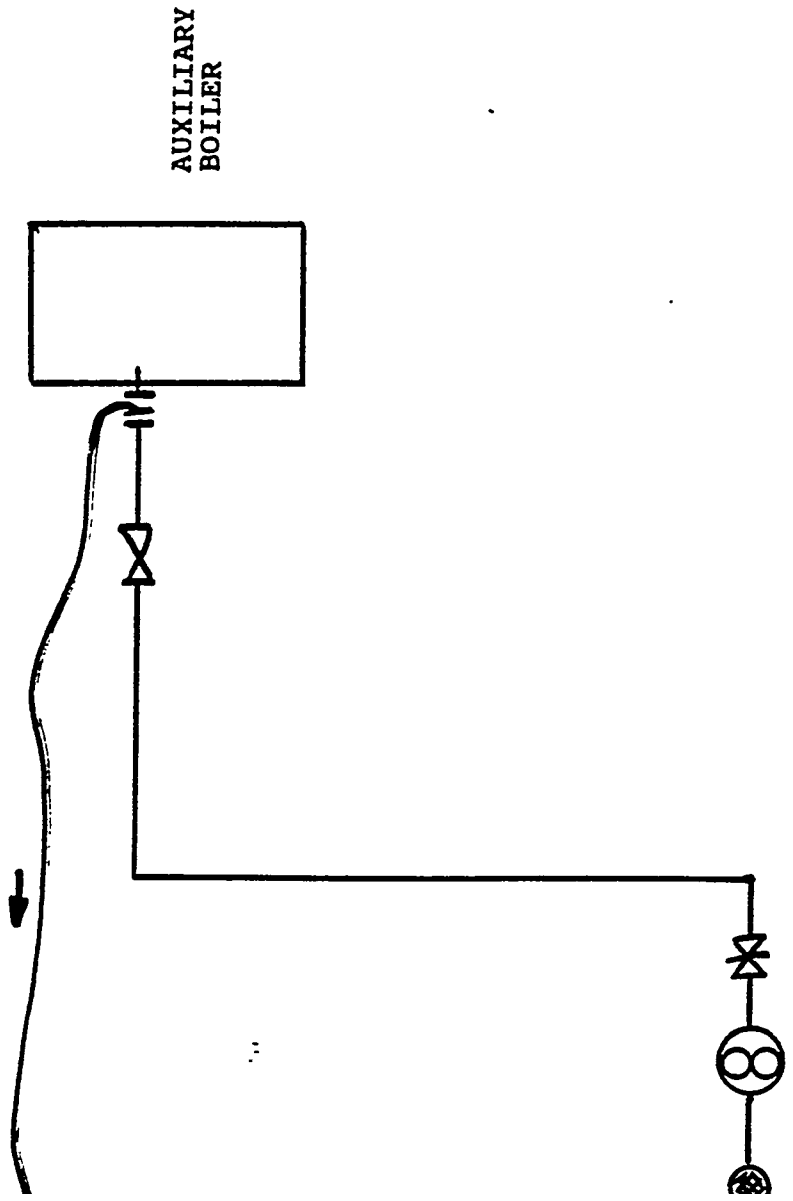

AUXILIARY
BOILER

L OIL IGNITION/PILOT PUMP

ENCLOSURE 15

SIZE	NASSCO DRAWING NUMBER	REV
A	445-342-7141	A
SCALE:	NONE	SHEET 77

Y BOILER
PILOT PIPING

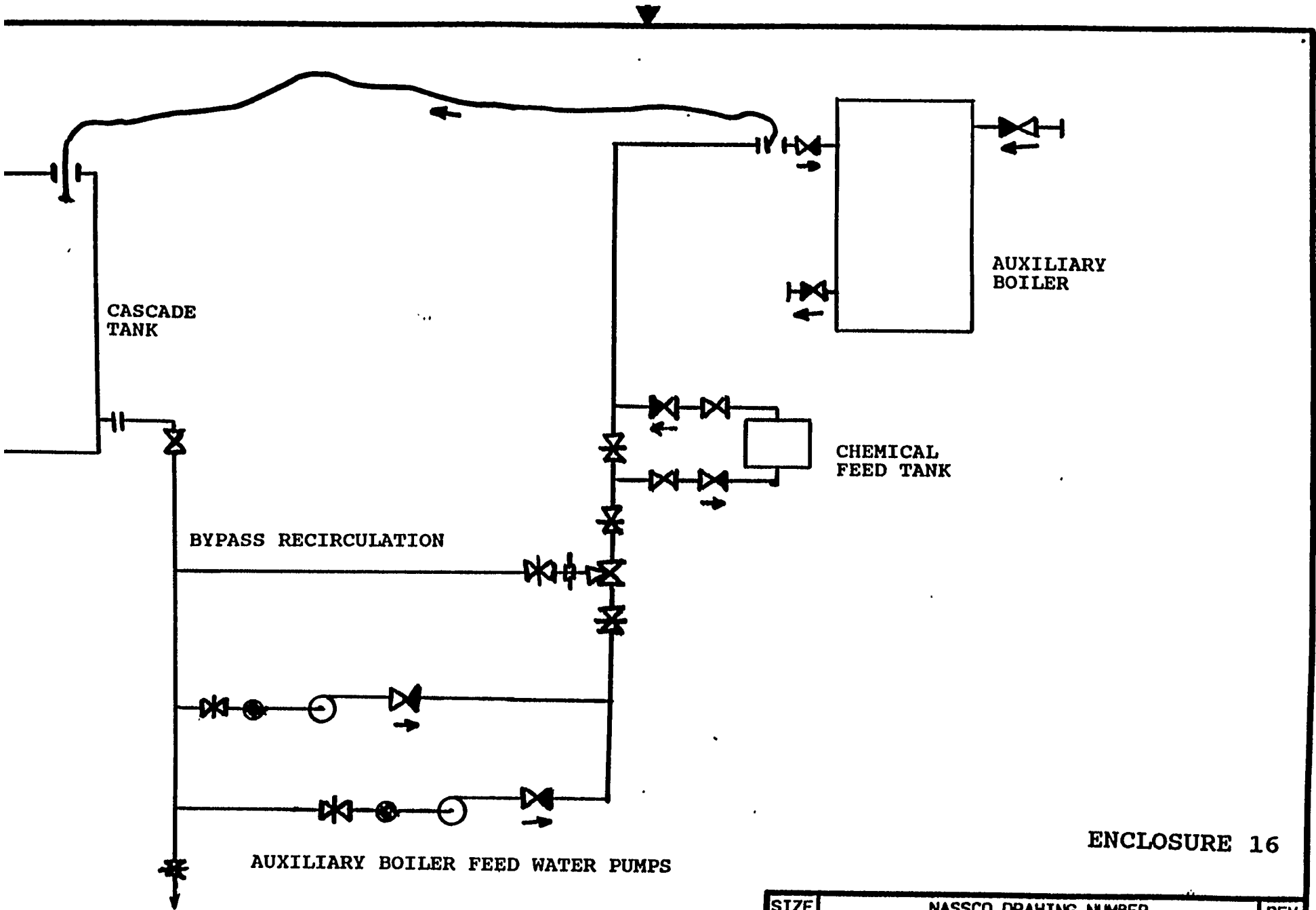

**FLUSHING OF AUXILIARY
BOILER FEED PIPING**

ENCLOSURE 16

SIZE	NASSCO DRAWING NUMBER	REV
A	445-342-7141	A
SCALE:	NONE	SHEET 78

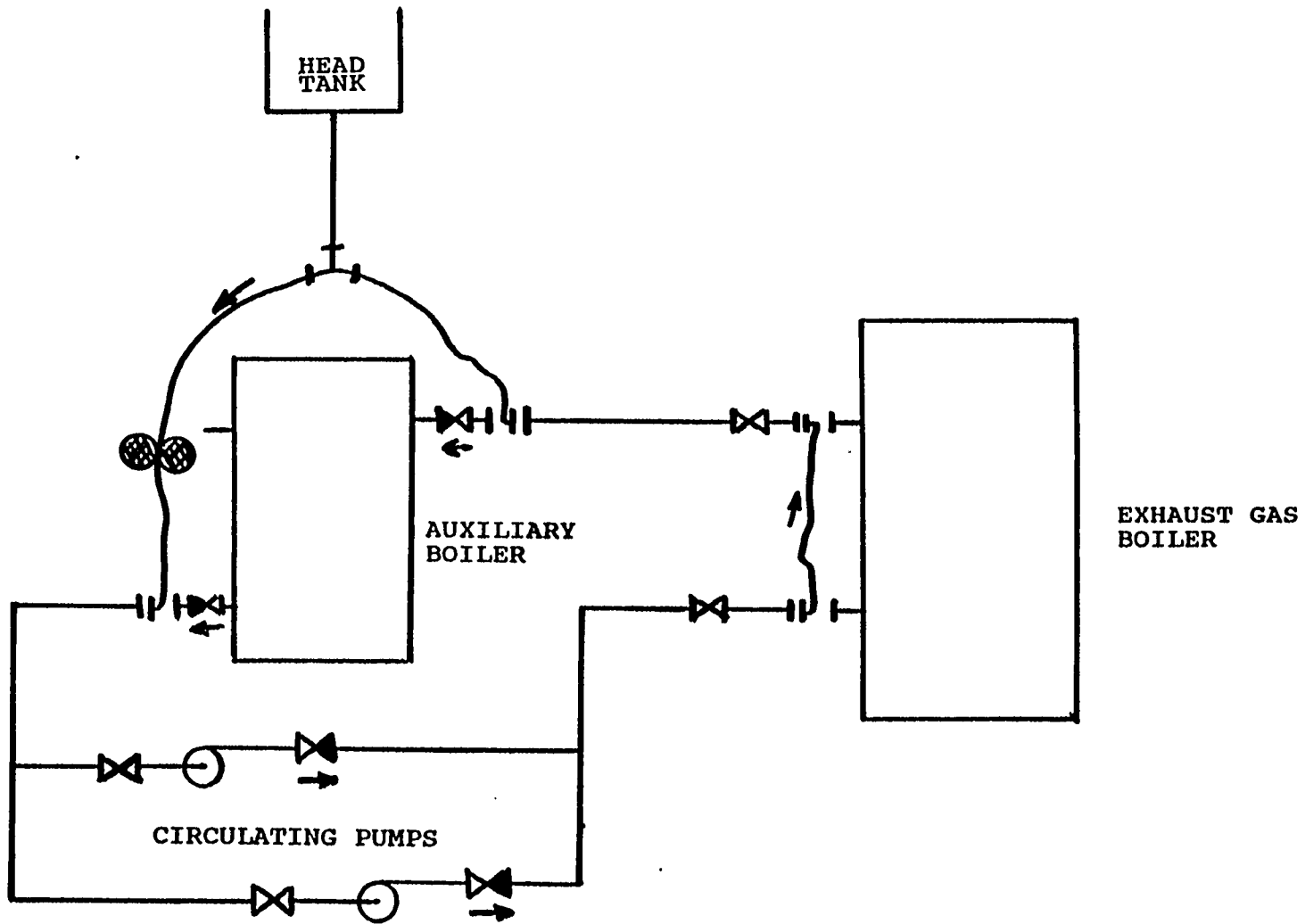

ENCLOSURE 17

FLUSHING OF EXHAUST GAS BOILER
CIRCULATING PIPING

SIZE	NASSCO DRAWING NUMBER	REV
A	445-342-7141	A
SCALE:	NONE	SHEET 79

**FLUSHING OF LUBE OIL TRANSFER PUMP
SUCTION AND DISCHARGE PIPING**

A²¹

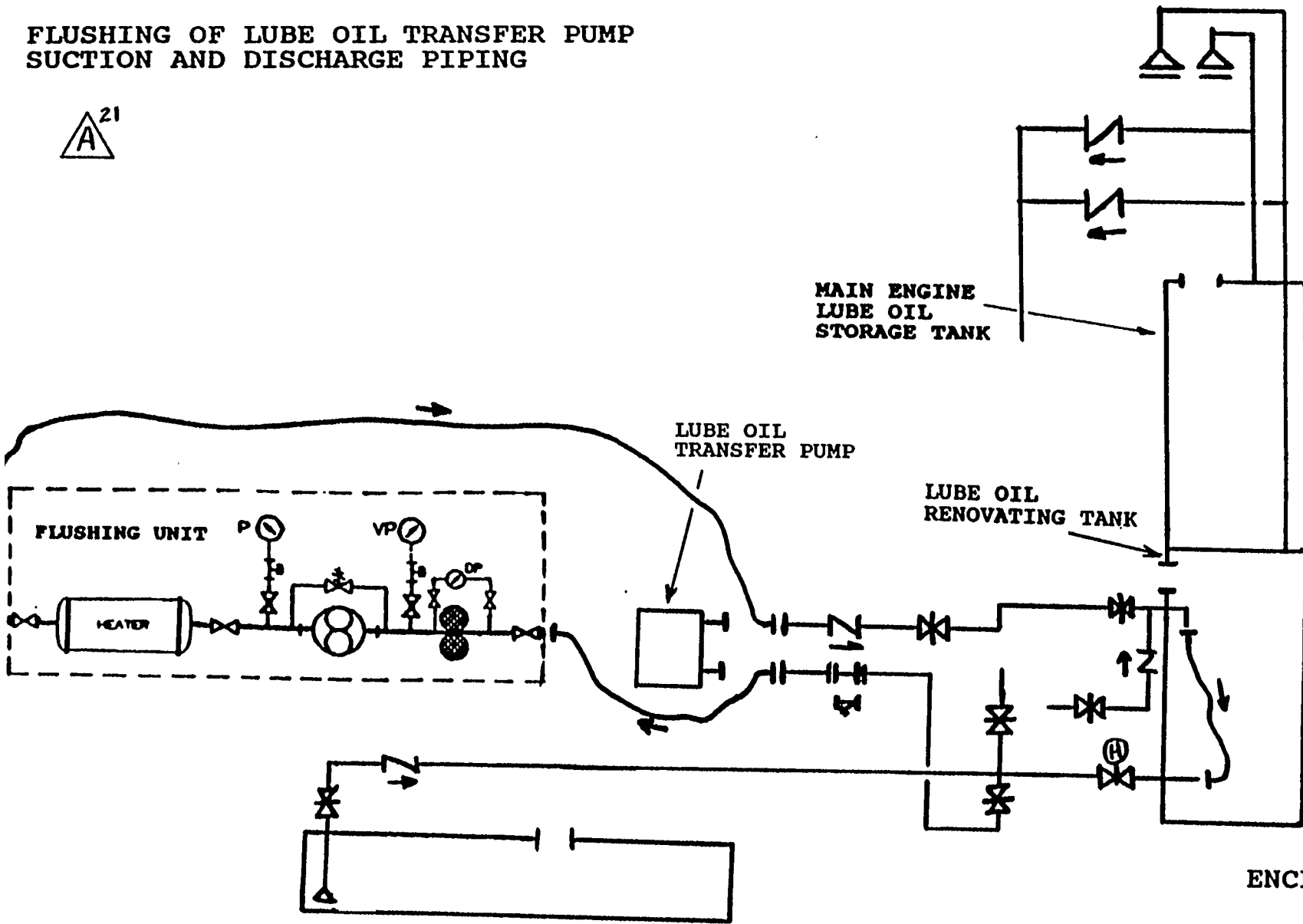

ENCLOSURE 18

SIZE	NASSCO DRAWING NUMBER	REV
A	445-342-7141	A
SCALE:	NONE	SHEET 80

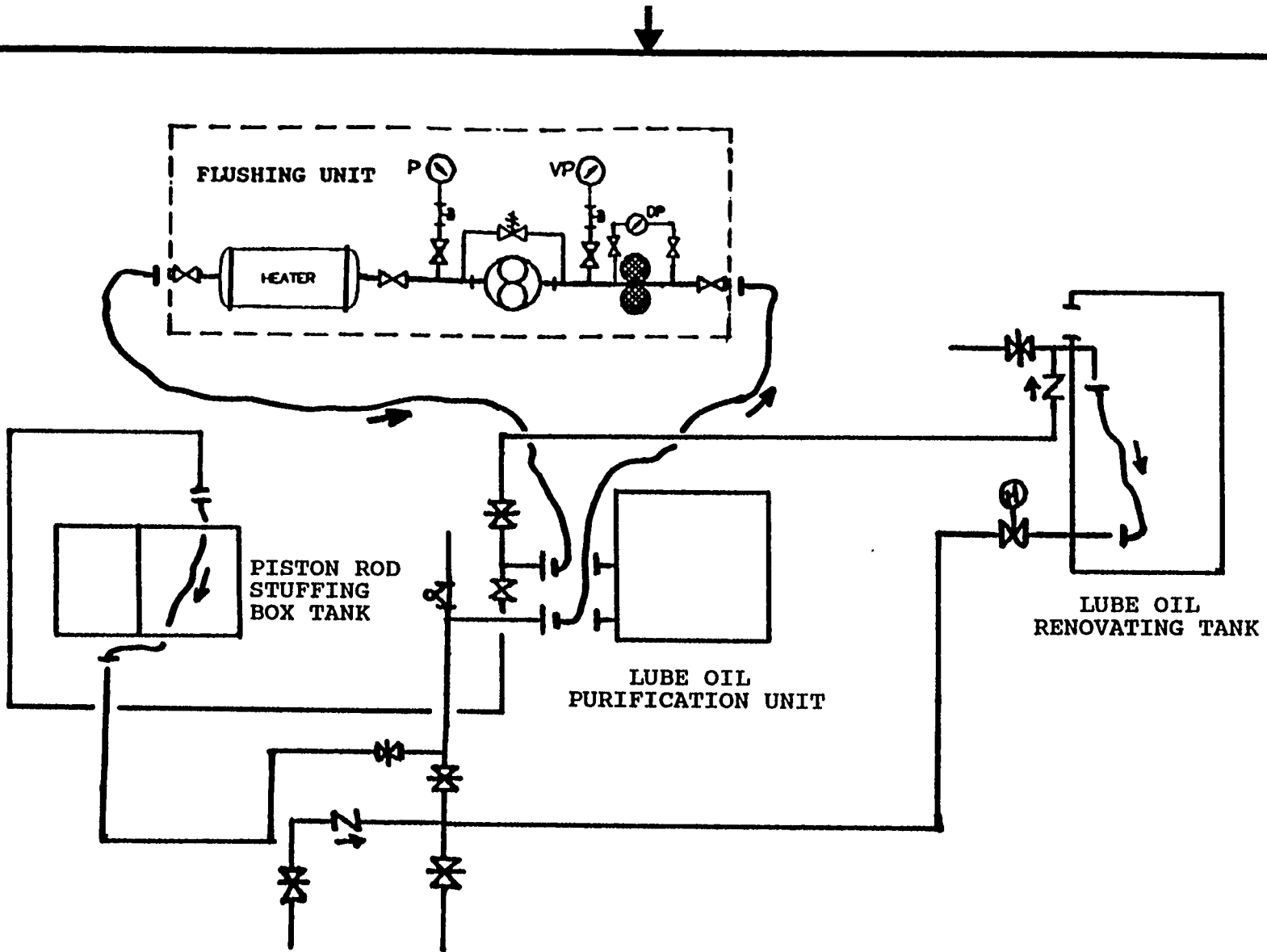

A²²

ENCLOSURE 19

FLUSHING OF LUBE OIL PURIFIER PIPING FOR RENOVATING TANK AND PISTON ROD STUFFING BOX TANK

SIZE	NASSCO DRAWING NUMBER	REV
A	445-342-7141	A
SCALE:	NONE	SHEET 81

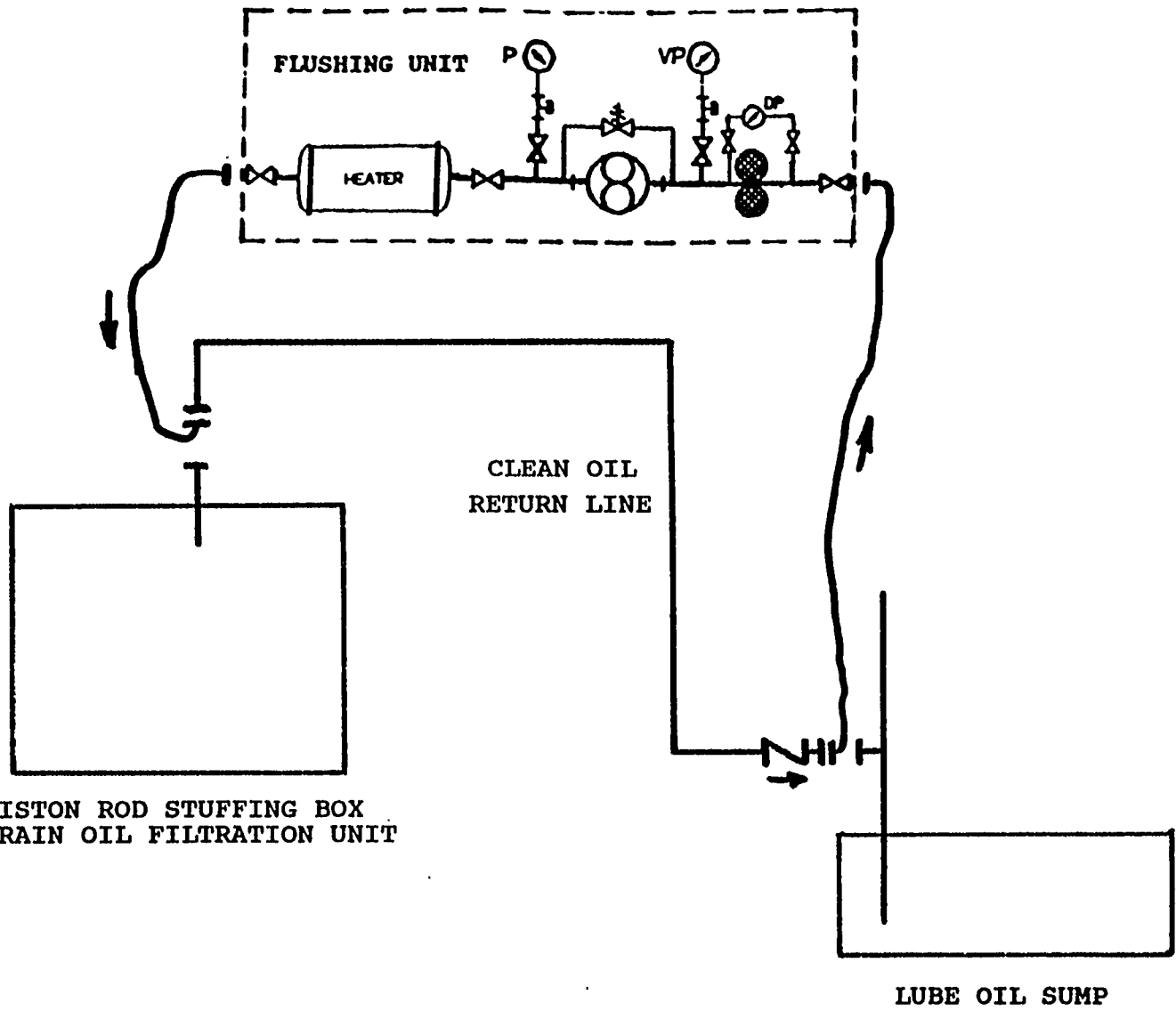

A²³

FLUSHING OF FILTRATION UNIT CLEAN OIL RETURN LINE TO MAIN ENGINE LUBE OIL SUMP

ENCLOSURE 20

SIZE	NASSCO DRAWING NUMBER	REV
A	445-342-7141	A
SCALE:	NONE	SHEET 82

LABORATORY REPORT

Telephone (619) 425-1993

Established 1928

CLARKSON LABORATORY AND SUPPLY INC.
350 Trousdale Dr. Chula Vista, Ca. 91910
ANALYTICAL AND CONSULTING CHEMISTS

Date: March 26, 1992
Purchase Order Number: JT176248
Sales Order Number: 31928
Account Number: NAT

To:

National Steel and Shipbuilding Co,
P.O, Box 85278
San Diego, CA. 92138
Attention: Ingersoll Mail Stop 24
Attention: Bryan Barefield (QA)

Laboratory Number: PC-2648 Customers Phone No: 232-4011

Sample Designation:
-----*

One oil sample marked L.O Piping dated 3-20-92

Table with 3 columns: Particle Size in Microns, Number of Particles per 100ml Sample, and SAE 749D Class 5 Specifications. Rows include particle size ranges from 5-10 to over 100 microns.

Note: This sample meets Class 5 SAE749D

Note: K = 1000

THE NSRP NEEDS YOUR EVALUATION OF THIS REPORT!

PLEASE RETURN A RESPONSE CARD AFTER READING REPORT.

NSRP READER RESPONSE CARD

We would appreciate your comments on this report. Please take a few minutes to complete and return this postage-paid card. Thank you.

Name _____

Organization _____

Phone _____

• Overall Quality of Report

Excellent Good Fair Poor

• Usefulness to You/Your Organization

Very Useful Moderately Useful N/A

• Did/Will your organization implement the results of this project? Yes No

If not, why? _____

• How Did You Receive Report?

Mailed directly to you
 Referred to you by someone else

• Did/Will You Pass Report On To Someone Else?

Yes No

• In Your Opinion, Is Anything Missing That Would Make This Report Better?

Yes _____

• General Comments

NSRP 0355

NSRP READER RESPONSE CARD

We would appreciate your comments on this report. Please take a few minutes to complete and return this postage-paid card. Thank you.

Name _____

Organization _____

Phone _____

• Overall Quality of Report

Excellent Good Fair Poor

• Usefulness to You/Your Organization

Very Useful Moderately Useful N/A

• Did/Will your organization implement the results of this project? Yes No

If not, why? _____

• How Did You Receive Report?

Mailed directly to you
 Referred to you by someone else

• Did/Will You Pass Report On To Someone Else?

Yes No

• In Your Opinion, Is Anything Missing That Would Make This Report Better?

Yes _____

• General Comments

NSRP 0355



NO POSTAGE
NECESSARY
IF MAILED
IN THE
UNITED STATES

BUSINESS REPLY MAIL
FIRST CLASS MAIL PERMIT NO. 2635 SAN DIEGO CA

POSTAGE WILL BE PAID BY ADDRESSEE

NASSCO/NSRP PROGRAM MANAGER

ATTN: Lyn Haumschilt M.S. 04A
National Steel and Shipbuilding Co.
P.O. Box 85278
San Diego, CA 92186-5278



NO POSTAGE
NECESSARY
IF MAILED
IN THE
UNITED STATES

BUSINESS REPLY MAIL
FIRST CLASS MAIL PERMIT NO. 2635 SAN DIEGO CA

POSTAGE WILL BE PAID BY ADDRESSEE

NASSCO/NSRP PROGRAM MANAGER

ATTN: Lyn Haumschilt M.S. 04A
National Steel and Shipbuilding Co.
P.O. Box 85278
San Diego, CA 92186-5278



Additional copies of this report can be obtained from the National Shipbuilding Research Program Coordinator of the Bibliography of Publications and Microfiche Index. You can call or write to the address or phone number listed below.

NSRP Coordinator
The University of Michigan
Transportation Research Institute
Marine Systems Division
2901 Baxter Rd.
Ann Arbor, MI 48109-2150
Phone: (313) 763-2465
Fax: (313) 936-1081