



Edgewood Chemical Biological Center

Air Flow Patterns Around Several Biological Point Detection System Configurations

Daniel G. Wise, Daniel J. Weber, Donna L. Carlile

Research Directorate

U.S. Army Edgewood Chemical Biological Center (ECBC)

Aberdeen Proving Ground, Maryland

2003 Joint Service Scientific Conference on Chemical & Biological Defense Research

November 19, 2003

Towson, Maryland

Report Documentation Page

Form Approved
OMB No. 0704-0188

Public reporting burden for the collection of information is estimated to average 1 hour per response, including the time for reviewing instructions, searching existing data sources, gathering and maintaining the data needed, and completing and reviewing the collection of information. Send comments regarding this burden estimate or any other aspect of this collection of information, including suggestions for reducing this burden, to Washington Headquarters Services, Directorate for Information Operations and Reports, 1215 Jefferson Davis Highway, Suite 1204, Arlington VA 22202-4302. Respondents should be aware that notwithstanding any other provision of law, no person shall be subject to a penalty for failing to comply with a collection of information if it does not display a currently valid OMB control number.

1. REPORT DATE 19 NOV 2003	2. REPORT TYPE N/A	3. DATES COVERED -	
4. TITLE AND SUBTITLE Air Flow Patterns Around Several Biological Point Detection System Configurations		5a. CONTRACT NUMBER	
		5b. GRANT NUMBER	
		5c. PROGRAM ELEMENT NUMBER	
6. AUTHOR(S)		5d. PROJECT NUMBER	
		5e. TASK NUMBER	
		5f. WORK UNIT NUMBER	
7. PERFORMING ORGANIZATION NAME(S) AND ADDRESS(ES) Research Directorate U.S. Army Edgewood Chemical Biological Center (ECBC) Aberdeen Proving Ground, Maryland		8. PERFORMING ORGANIZATION REPORT NUMBER	
9. SPONSORING/MONITORING AGENCY NAME(S) AND ADDRESS(ES)		10. SPONSOR/MONITOR'S ACRONYM(S)	
		11. SPONSOR/MONITOR'S REPORT NUMBER(S)	
12. DISTRIBUTION/AVAILABILITY STATEMENT Approved for public release, distribution unlimited			
13. SUPPLEMENTARY NOTES See also ADM001851, Proceedings of the 2003 Joint Service Scientific Conference on Chemical & Biological Defense Research, 17-20 November 2003. , The original document contains color images.			
14. ABSTRACT			
15. SUBJECT TERMS			
16. SECURITY CLASSIFICATION OF:			17. LIMITATION OF ABSTRACT
a. REPORT unclassified	b. ABSTRACT unclassified	c. THIS PAGE unclassified	UU
			18. NUMBER OF PAGES 41
			19a. NAME OF RESPONSIBLE PERSON



Introduction

Current bio-defense point detection systems depend on acquiring a sample of the ambient aerosol.

The aerosol inlet to the collection system is therefore a primary component & crucial to the performance of the entire point detection system.

Flow field around and to an inlet intake is important issue when considering the performance of a point detection system

Inlet placement with respect to other objects in the flow field can have an impact on the performance of the system.

For example:

- The inlet could be sampling from recirculation zones where interferents accumulate
- The inlet may be in a flow field where the ambient aerosol cannot be directly aspirated
- There could be local flow accelerations or vectoring to inlet at non-design orientations



Background

- The subject of flow field near inlets is applicable to any collector system used for a variety of purposes (environmental, health& safety, Homeland Security, Bio-Defense).
- JBPDS was the particular system used in this study.
 - high flow rate wetted wall cyclone used to collect aerosol samples.
 - samples analyzed by assay to identify bio-agents.
 - fluorescence based particle analyzer (BAWS) used as a trigger device to manage consumables.

Background

Edgewood Chemical Biological Center

JBPDS, All Services, Many Platforms

JOINT BIOLOGICAL POINT DETECTION SYSTEM

Capability Across Joint Battlespace for Use By All Services

MILITARY TRAILER

JBPDS BIOD

SHIPBOARD

COMMERCIAL TRAILER

JBPDS LRIP
Basic Biological Suite Unit (BBSU)

PORTABLE

JELN8CR8 (HMMWV)

JELN8CR8 (LAV)

JAV-N8CR8

Labels in central LRIP diagram: Mobile Control, Waste/Used Cartridge Container, Monitor, Joint Control Processor (JCP), Local Control Station & I/O Controller, Sample Inlet & I/O Controller, Instrument Panel, GARD II Detector, Fluid Transfer System (FTS)

PEW-CBD

Proven Top Performer for Biological Detection



Silhouettes of JBPDS Configurations Considered

Vehicle Mounted Shelter Configuration

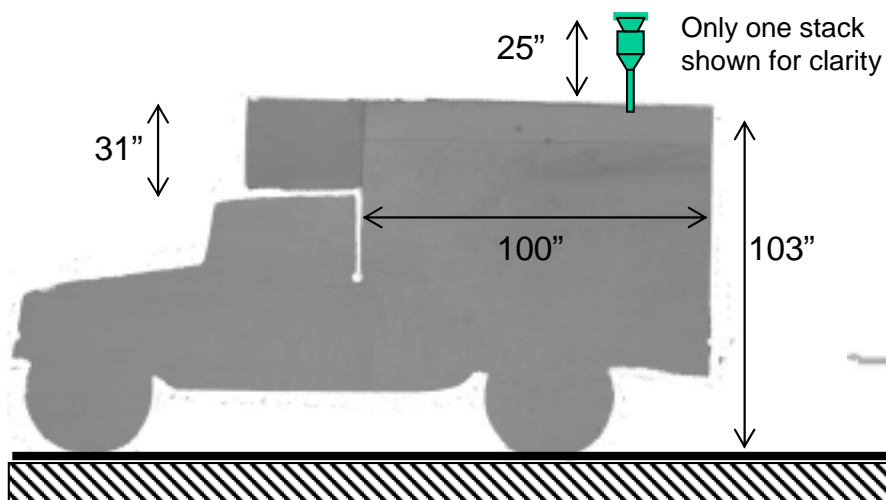

Trailer Mounted Configuration

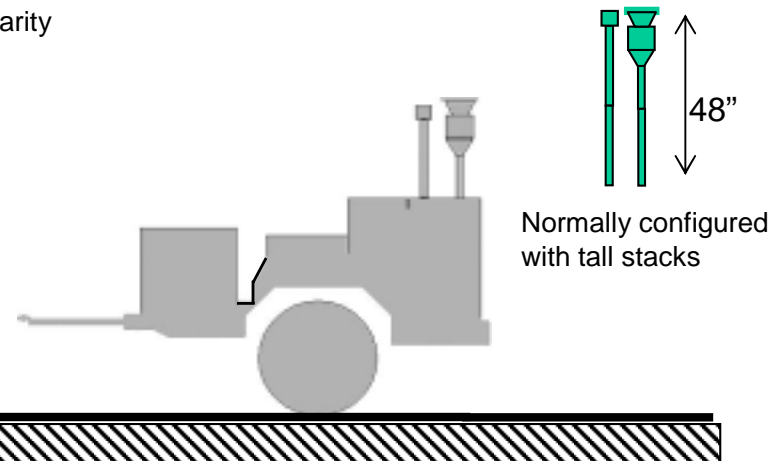



Background

Question: Inlet position is fixed by interior component layout, what is a good inlet height to insure the trigger obtains a good sample from ambient air at personnel level without aspirating interferences from ground.

Approach: Evaluate flow over Vehicle & Trailer config.

- Flow Visualization
 - Scale models in wind tunnels
 - Actual JBPDS in breeze tunnel (trailer)
 - Actual JBPDS in outside breeze (vehicle)
- Simple CFD modeling

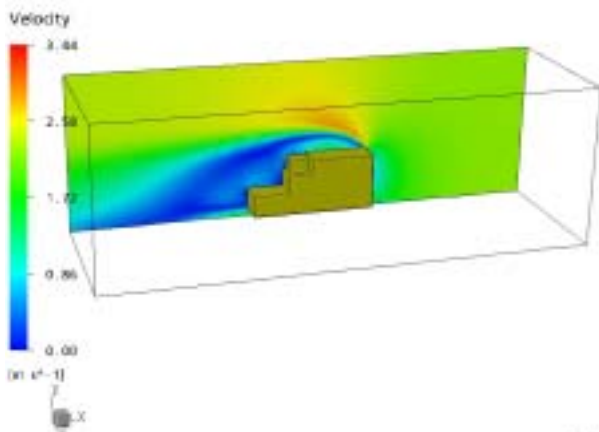

CFX





Background

Wind tunnel testing vs Full scale testing

- Actual JBPDS is large. Requires large test facility
 - Difficult to produce controlled environment necessary for good flow visualization. (streamlines)
- Wind tunnel testing using scale models is a standard practice as an alternative to full scale testing.
 - Flow patterns over scale models should be the same as full scale patterns if Reynolds numbers (ratio of inertial to viscous forces) are maintained.

$$Re = \frac{V d}{\nu}$$



Background: Wind tunnel testing vs Full scale testing Vehicle Mounted Configuration

- Full Scale $Re = 318K$ at 4-mph,
- Wind tunnel scale and test velocity chosen to match Re
 - Compromise test issues such as test section blockage and smoke dilution with increasing wind speed.
 - In our facilities flow visualization is best conducted in the 20-40 mph range
 - Test section blockage below 10%.
- 8% scale model was chosen and test velocity was in the 20-mph range for best photography of streamlines (blockage=9% CFD used to show flow patterns unaffected)
- **Wind tunnel $Re = 130K$ at 20-mph (for non-laminar flow this would be considered a similar flow regime as the 318K full scale vehicle in a breeze).**
 - Previous flow visualization work shows Reynolds number independence in test velocity range of 20 to 75-mph

Also, to supplement the wind tunnel study we tried open air testing of actual JBPDS vehicle using ambient breeze. This was minimally successful, but some important observations did result and are presented subsequent to the results of the wind tunnel study.



Background: Wind tunnel testing vs Full scale testing

Trailer Mounted Configuration

- Trailer mounted version is smaller than Vehicle mounted version.
 - Tested scale model in wind tunnel (Scale: 20% $Re=127K$ at 20mph)
 - Tested in large breeze tunnel ($V=4$ -mph, $Re=127K$)

Details of wind tunnel facility



Edgewood Chemical Biological Center

Subsonic Wind Tunnel

- 28x40-inch test section
- 3 Configurations
 - Generic aerosol mixer insert for sampler inlet efficiency studies 10-60-mph
 - Aerosol Confinement Sleeve Insert for UAV or high speed inlet studies (10-140 mph)
 - Clean Tunnel for aerodynamic testing (flow, force,& moment) (10-140 mph)

Test Equipment

Flow visualization with smoke wand (Nutem –no longer available). Images recorded with hi-8 video, digital video, and digital still camera





Part 1: JBPDS Mobile Shelter Version

Vehicle Mounted Shelter Configuration

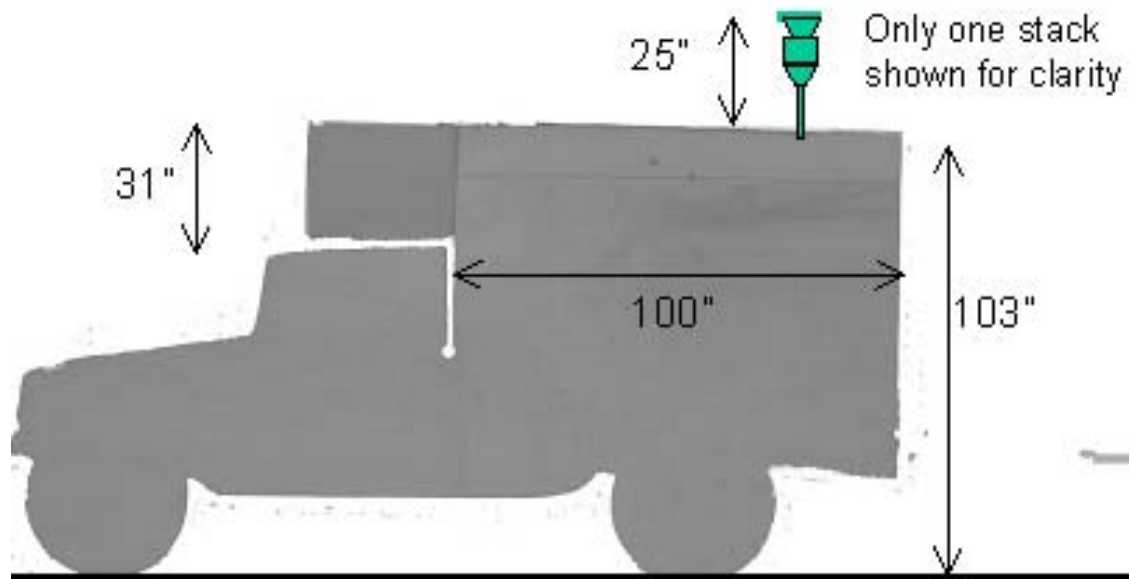

Historical Background:

Flow over a BIDS vehicle was studied in 1993 using 8% scale model. Various awning-type attachments to the shelter were modeled in an attempt to reduce the recirculation and wake zones to improve airflow to the inlets. A curved awning worked very well, but would be cumbersome to implement on actual vehicle. A straight awning that would be simpler to implement was tested. Flow was not as nice as curved awning, but better than no awning. These awnings were modeled as solid material, not porous netting as employed current JBPDS system. Also note that the awning angle appears to be shallower than the angle of deployed camo net.

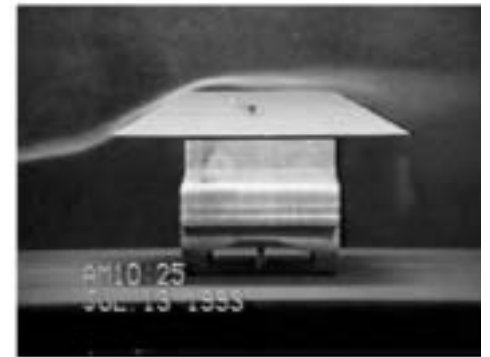
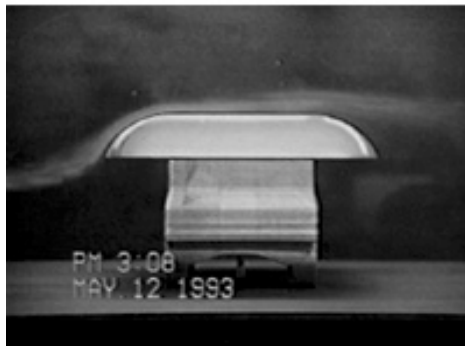
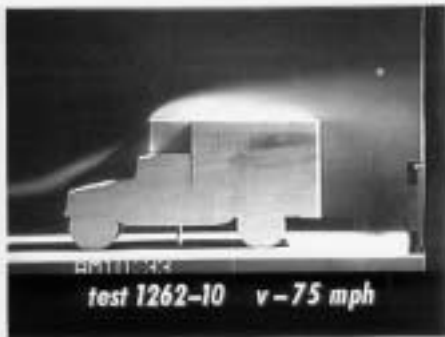
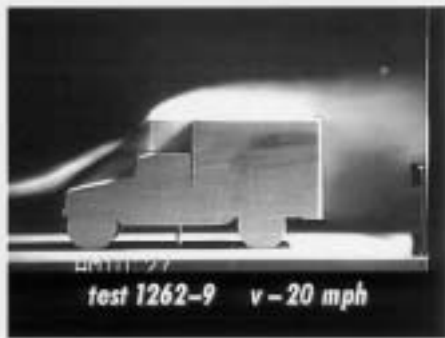



Preliminary Calculations: estimate flow zones

ASHRAE handbook details design procedure for required stack height to avoid contamination developed by Wilson (1979) which estimates regions of wakes, turbulence, and recirculation around buildings. As a first cut, we use this procedure to estimate these air flow zones over the JBPDS.

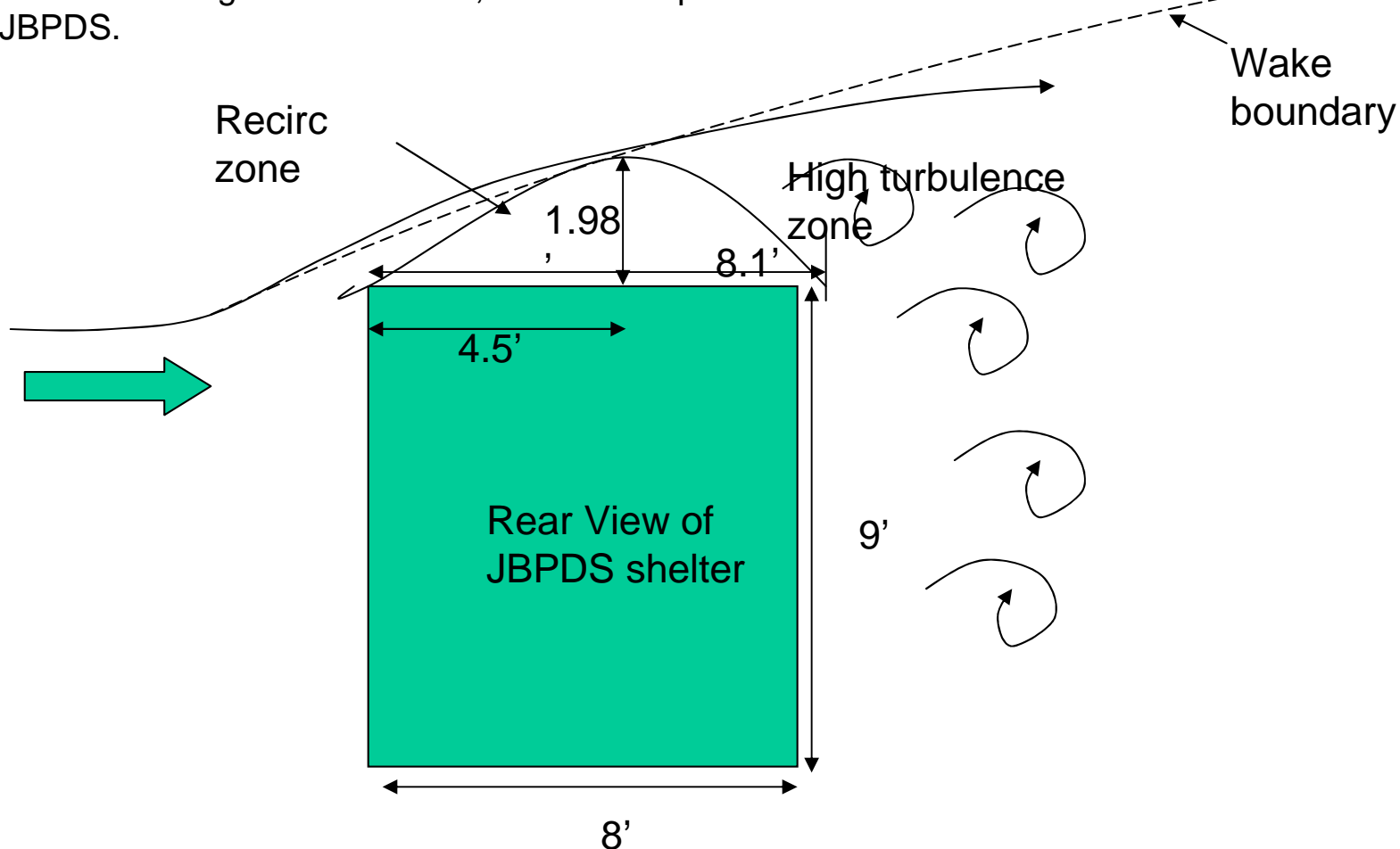

Details of wind tunnel model



Actual JBPDS



Actual JBPDS Camouflage net

JBPDS model 1:12.5 (8%) scale



JBPDS model w/ screen simulating camo net

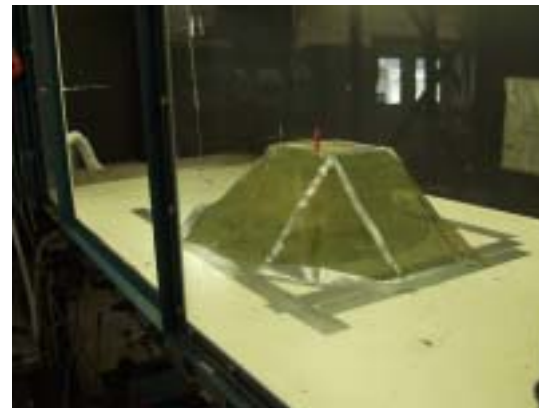

Test Configurations

JBPDS operations dictate use of camo net. Could affect airflow. Hard to assure correct modeling in scale. So test at extremes and best guess model, ie: without net, with fine mesh screen fabric to match full scale porosity test, and with non-porous net.

Test at forward facing orientation (SOP for JBPDS deployment) and Side to wind with inlets on lee side (worst case for airflow to inlet)



No camo net



Camo net modeled with screen mesh



Non-porous camo net model

Analysis

Convert photos to high contrast to emphasize streamlines

Measure flow regions from photos

Back-trace streamlines from inlet height to free-stream height (effective sampling height)



High contrast
to emphasize
streamlines

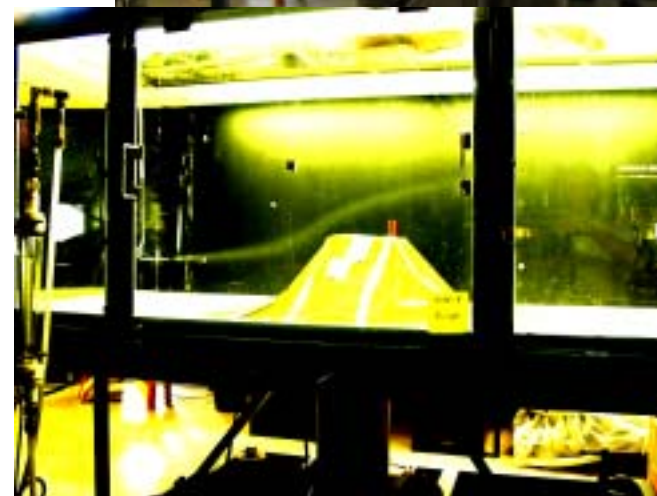

Example of analysis

Forward facing, scaled camo (screen fabric)



Flow from 3.5-ft approach level is directed over inlet

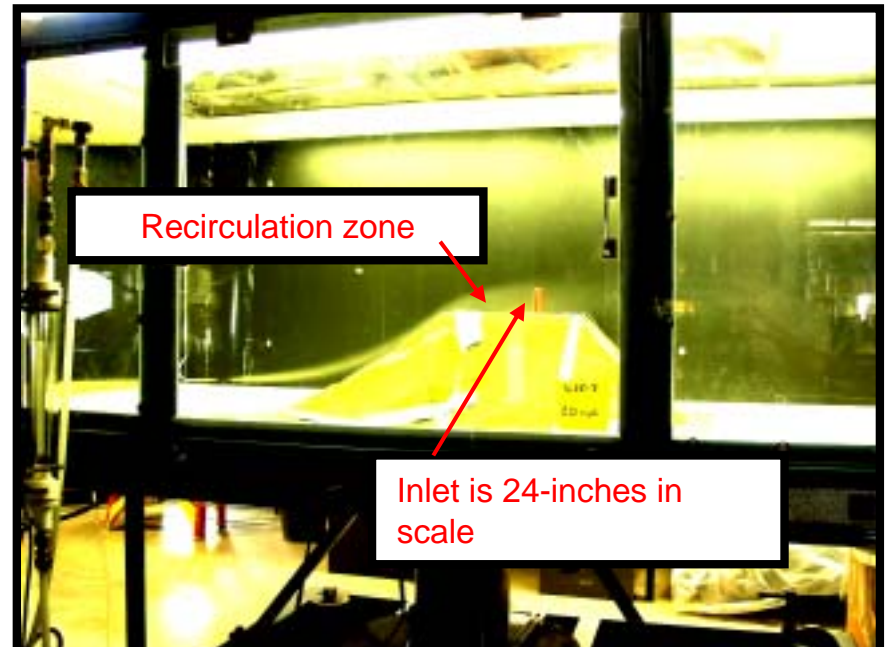

Flow from 2-ft approach level is directed to inlet recirculation zone

Example of analysis

Side forward (worst case flow) with various camo configs and approach streamline heights

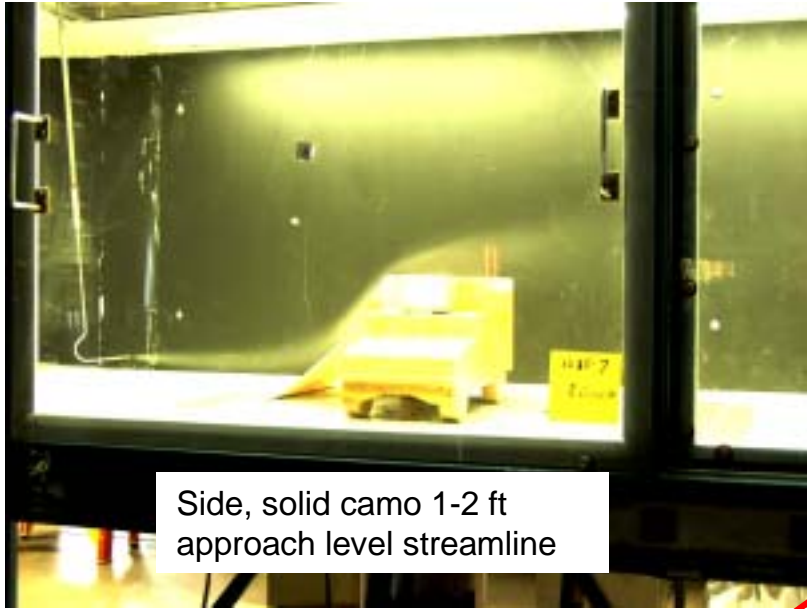

Side, solid camo 1-2 ft approach level streamline

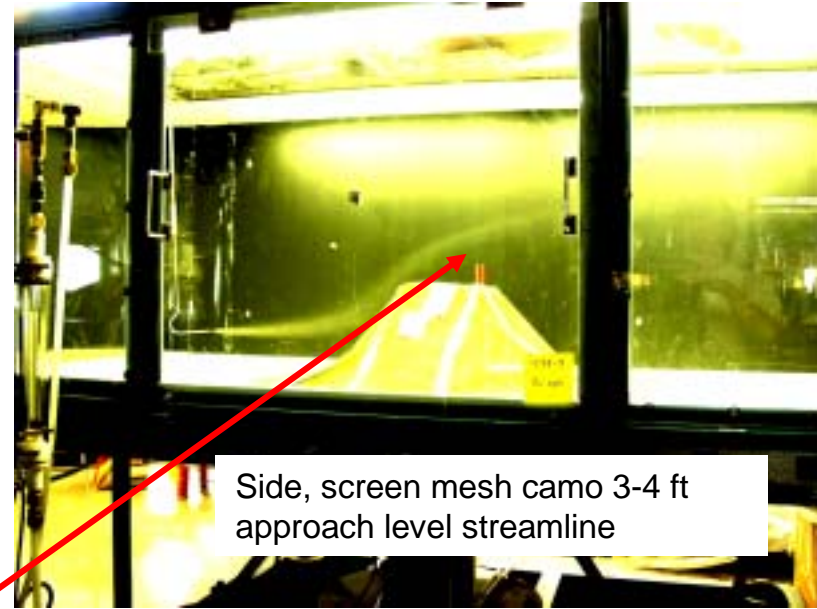

Side, screen mesh camo 3-4 ft approach level streamline

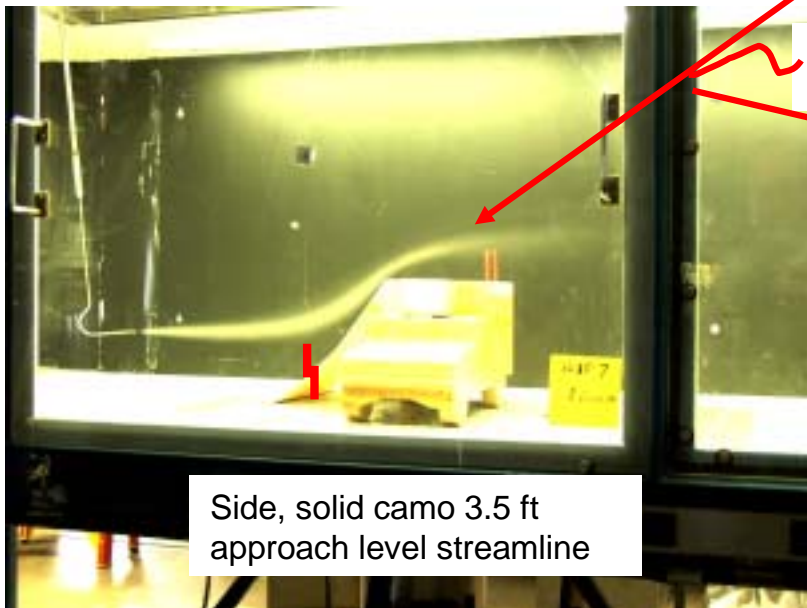

Side, solid camo 3.5 ft approach level streamline

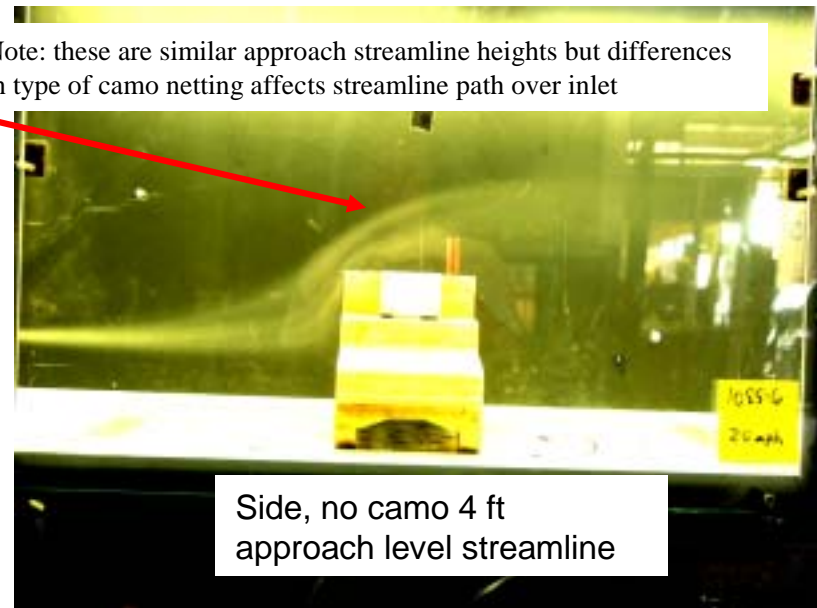

Side, no camo 4 ft approach level streamline

Note: these are similar approach streamline heights but differences in type of camo netting affects streamline path over inlet

Outdoor testing w/ actual JBPDS draped in camo netting

- Very mild breeze test condition (0 to 4-mph)
- Difficult to visualize flow to inlet area, wind was unsteady and turbulent
- No quantitative measurements possible
- Flow was as inclined to go around the object as over the top
- In very light wind the flow would see camo netting as a wall and go around or over
- In heavier winds the flow seemed to go right through the net, and emerge on the lee side of vehicle. Smoke would then persist in the lee wake region of vehicle

Difficult to maintain good smoke visualization



Flow going over vehicle and netting to inlets



Flow going through netting and emerging/persisting in rear wake area



CFD Modelling

Subsequent to the wind tunnel flow visualization, simple CFD modeling was performed

Flow approaching from front of vehicle

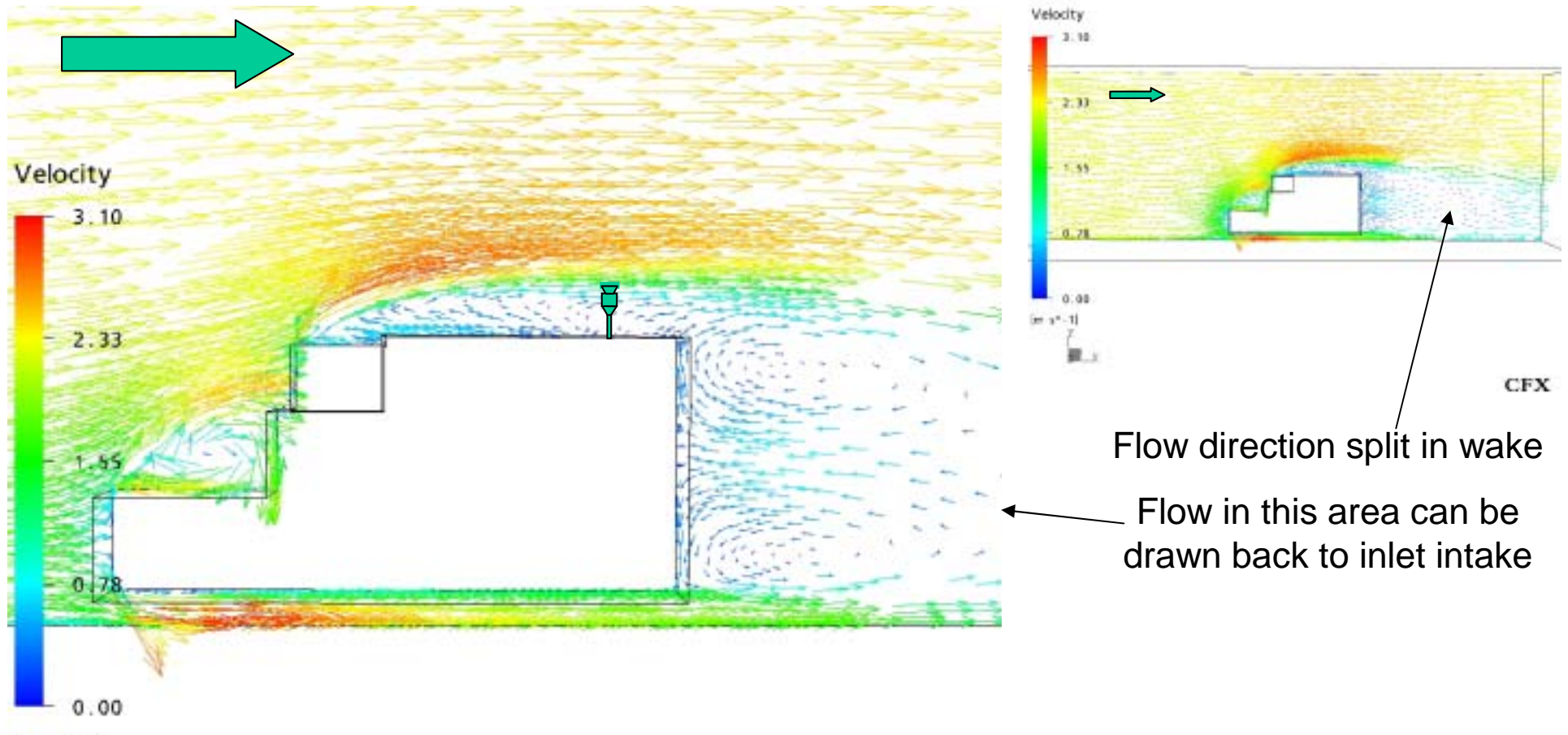

CFD Modelling

Subsequent to the wind tunnel flow visualization, simple CFD modeling was performed

Flow approaching from rear of vehicle

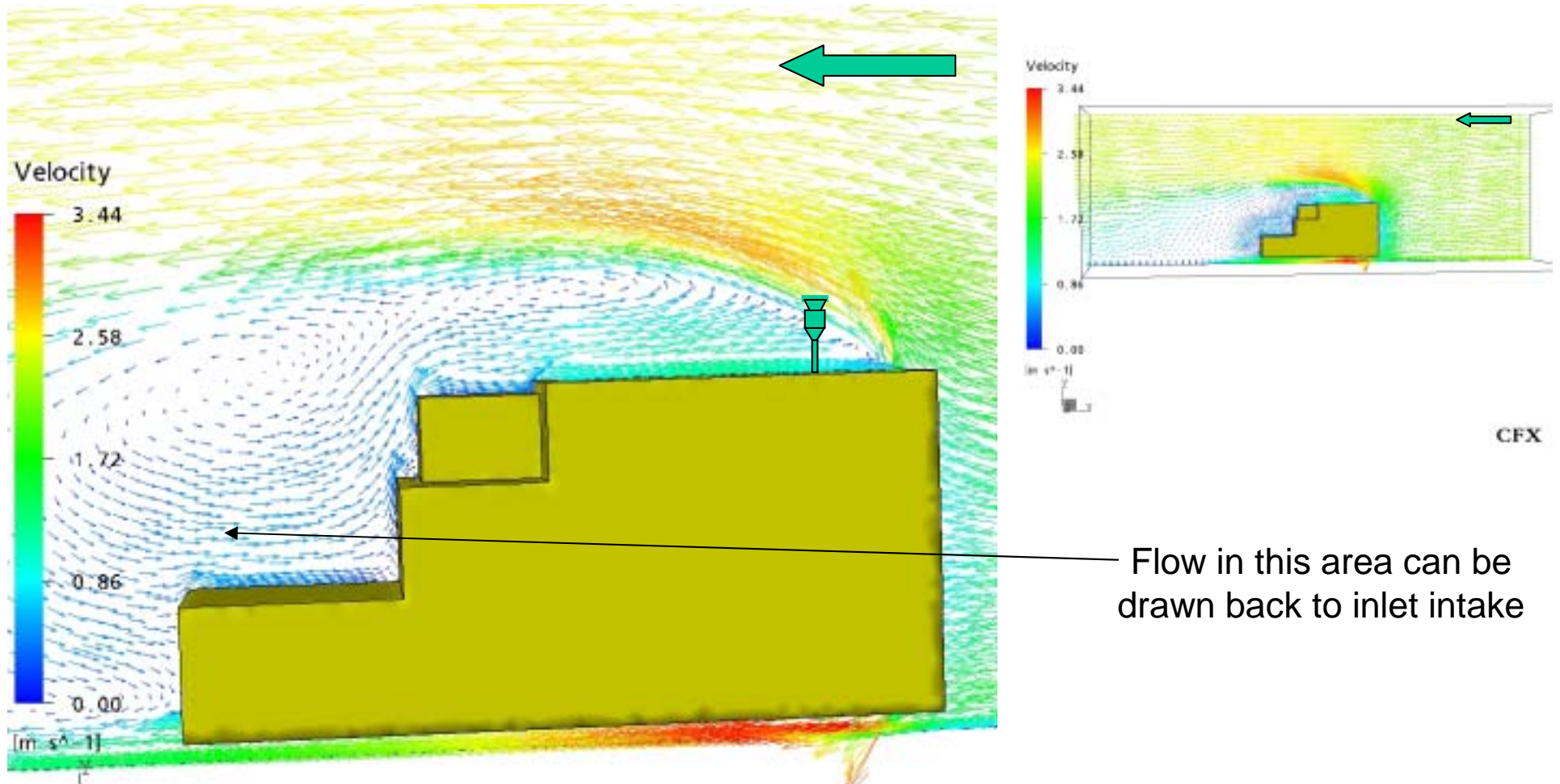

Discussion

Edgewood Chemical Biological Center



1. Wind tunnel modeling verified:

- Handbook calculated and CFD predicted flow patterns over simple blocks which approximate the side forward shape of the JBPDS agree well with observed flow patterns. ASHRAE handbook predicts a recirculation zone of ~2 feet high, and observed flow pattern indicates the same in scale.
- CFD and previous flow visualization study confirm flow pattern independence of Reynolds number within the range used in wind tunnel testing.
- Actual camouflage net allows about 80% of flow to pass when oriented on a slant. Screen mesh was used to model this effect in wind tunnel testing.



Discussion

Edgewood Chemical Biological Center

2. Observations from Wind Tunnel Test:

- Different degrees of camouflage netting were used in testing. A solid fabric lessens the blunt shape of the vehicle and allows the flow to more closely follow the roofline, the mesh screen chosen to approximate the real camouflage net mitigates blunt body effects but not nearly as much as solid fabric, no camouflage net at all is worst case in terms of largest recirculation and wake zones. These observations are logical.
- The recirculation zones over the shelter are on the **same order of height as the inlet intakes** (it is unsteady flow and fluctuates plus and minus ~6 inches (full scale)).
- In a forward facing orientation (SOP for JBPDS deployment) and configured with the best guess approximation camo netting (mesh screen) the flow from about **4-ft approach level (flow ahead of the vehicle influence) will come closest to the inlet intake and seems to coincide with the upper edge of the recirculation zone.** Flow below this level trips over the leading edge of the shelter and enters the recirculation zone, Flow above this level passes smoothly above the inlet intake.
- In a side facing orientation creates largest recirculation zone. If the inlet is on the forward edge then it is easily in clean air flow, but **if on the lee side, it will be in the recirculation zone.**



Discussion

Edgewood Chemical Biological Center

3. Observations from open field testing of actual JBPDS Vehicle Shelter:

- Hard to get good results due to uncontrollable environment
- Effect of camouflage net on flow seems to be wind speed dependant.** At low speeds the net appears to deflect the smoke well (like a solid tarp) at higher velocity breezes, the smoke penetrates the netting and lingers underneath, eventually emerging on the lee-side of the vehicle
- Height of recirculation zone over the roof depends on the angle it approaches vehicle:** In a corner approach there is a very small recirculation zone-curls around edge, whereas **in a broad side approach there is a larger recirculation zone that could be as large as twice the height of inlet.**
- In all cases there was a large dirty wake that lingered behind vehicle for a long time

Discussion

Edgewood Chemical Biological Center



4. Observations from CFD model:

- Showed good agreement with flow visualization
- Showed details of flow not obvious in flow visualization

Ex: flow in wake regions can be drawn back against ambient flow and directed to inlet intake area. So placing a contaminating source downwind from system does not assure that it will not propagate back to inlet. (lesson: put exhaust tube from generators far beyond reverse flow region)



Part 1. Summary and Comments

Edgewood Chemical Biological Center

- Free stream air from about 3 to 4.5 feet above the ground is directed to inlet intake.
- Boundary of the recirculation zone above the JBPDS shelter vehicle coincides with inlet intake. Flux of particles into this zone is probably less than free stream but they are trapped there and persist and perhaps build up in concentration over time.
- Air flow from ground level is also directed to the roof level and can be entrained in the recirculation zone over the roof.
 - Also, dust that has settled on the net during still air conditions may be re-aerosolized when a breeze kicks up and directed by the flow over the leading edge lip of the shelter into this recirculation zone.
- As the boundary of the recirculation zone fluctuates, the inlet intake sometimes lies within this zone, therefore aspirating the dirtier air. This may be problematic for some trigger systems as it sees a fluctuating background aerosol.
- Contaminants from downwind sources can be drawn back to the inlets via reverse flow in wake and entrained in the recirculation zone



Part 1. Summary and Comments

Edgewood Chemical Biological Center

Should height of inlet be increased?

- Moving the inlet intakes up 2 feet would eliminate the question of flow field effects
- Trigger system would not be adversely affected and would probably see a steadier, less fluctuating particle/contaminant background.
- Collector assays are material specific.
 - Collecting dust along with bioagent not a problem.?
 - Perhaps recirculation zone can increase the local concentration and persistence of aerosol by trapping aerosol particles in the dead air region. *Perhaps* there is some benefit to having collector inlet in this region.
 - Quick follow on study was performed at Battelle's Ambient Breeze Tunnel facility. STAs were placed in recirculation zone and in free stream. Showed a very slight increase in concentration over roof. Inlet efficiency of STA was eliminated as a variable. However differences were not much above uniformity differences of tunnel. So test not definitive, but adds fodder to the speculation.



Part 2. Trailer Mounted Configuration

Edgewood Chemical Biological Center

Similar issues concerning inlet height have come up for the trailer mounted version of JBPDS. Consequently another series of wind tunnel test using a 20% scale model are planned. In addition, the smaller size of the trailer version allows the use of the ECBC breeze tunnel facility to conduct flow visualization tests on the actual trailer mounted system.



Part 2: Trailer Mounted Configuration

Edgewood Chemical Biological Center

Trailer Mounted Configuration

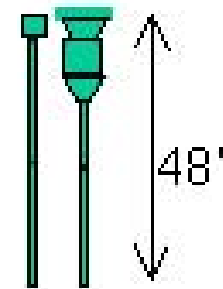
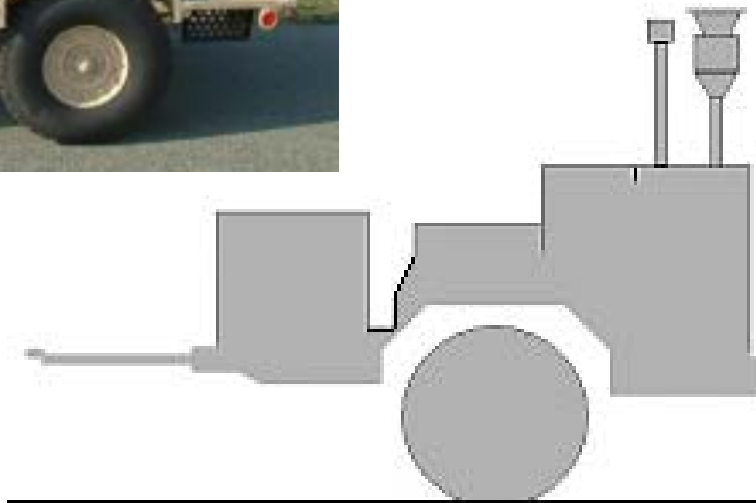

Normally configured
with tall stacks



JBPDS Trailer Mounted Configuration

Edgewood Chemical Biological Center

- Note that the trailer mounted version employs 24-inch extensions to raise the inlet intake height.
- The smaller size of the trailer version also permits the use of the ECBC breeze tunnel facility to conduct flow visualization tests on the actual trailer mounted system in a controlled wind environment (in contrast to the marginally successful open field testing (uncontrolled environment) of the vehicle version)
- A 20% scale model of the trailer version was rapid prototyped from the actual drawings. Flow visualization using smoke wand was performed with the model at various orientations to the wind. Worst case orientations were identified and flow to inlet intake area characterized.
- Tests were repeated with the trailer draped in simulated camouflage netting to assess the flow situation in the event that users deployed camouflage.
- Flow over full scale JBPDS was then evaluated in breeze tunnel in worst case orientation identified in the wind tunnel tests, with and without actual camouflage netting. Used the netting from the JBPDS vehicle configuration. This supplements and validates the flow fields visualized in the wind tunnel tests.

Trailer Mounted JBPDS Flow Study

Flow visualization over scale model in ECBC Wind Tunnel



wind tunnel facility and test set-up

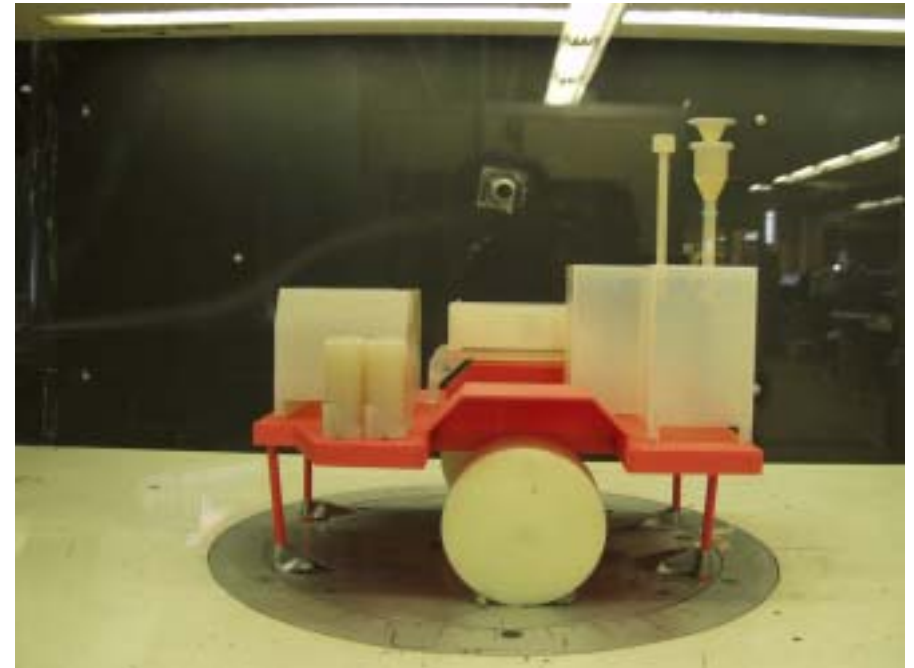

20% scale model in wind tunnel

Note: Inlet Stacks are modeled without extensions (26-inches high in full scale)



Trailer Mounted JBPDS Flow Study

Edgewood Chemical Biological Center

Flow visualization over scale model in ECBC Wind Tunnel

Model was rotated through 360-degrees, two orientations are shown here

High contrast photos of smoke visualization of flow over trailer

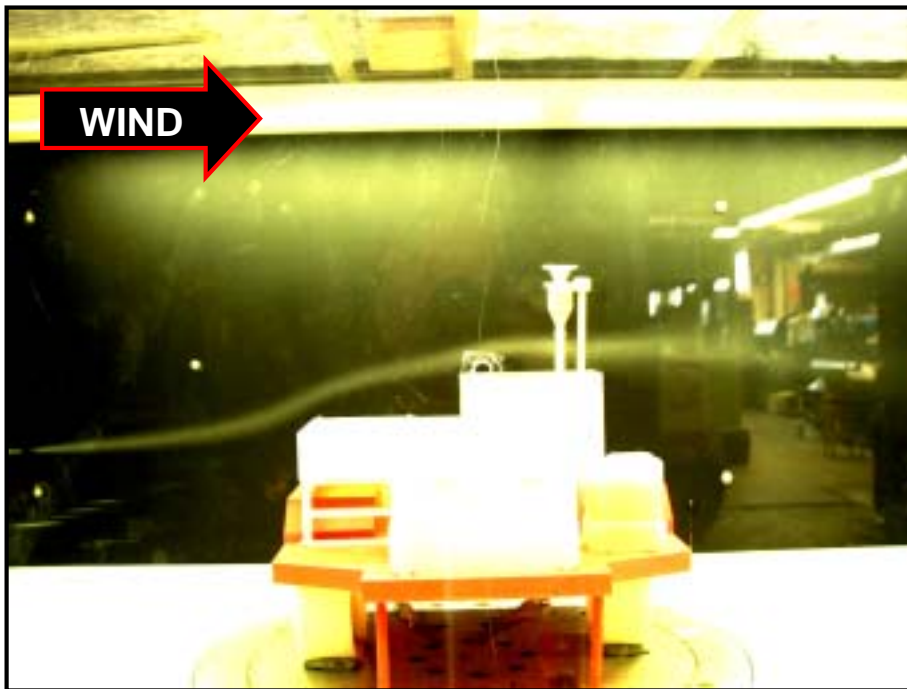

Trailer right side into wind orientation



Trailer forward into wind orientation

Trailer Mounted JBPDS Flow Study

Trailer Model with Camouflage Netting

Netting is draped over framework and deployed in fashion similar to photos obtained of actual trailer cloaked in General Dynamics camo material. Inlets (without stack extensions) protrude through net.

Camo netting porosity is hard to model accurately so two different porosity levels were modeled by layering the netting on the model

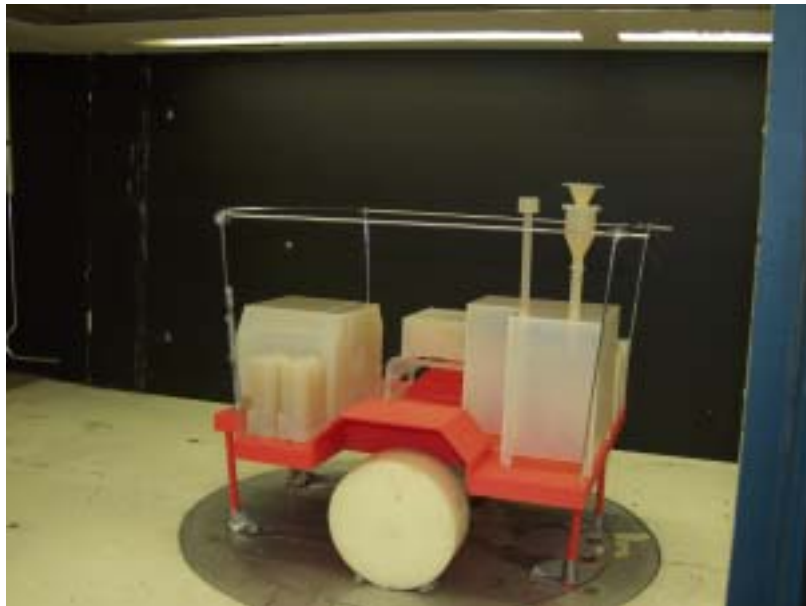

Trailer with framework



Trailer draped in one layer of fine weave netting

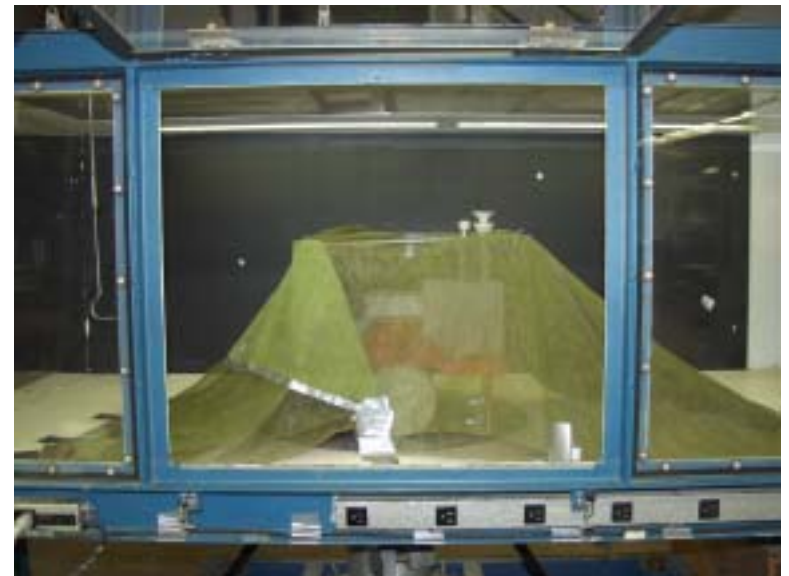

Trailer draped in fine weave and heavy weave netting

Trailer Mounted JBPDS Flow Study

Flow visualization over actual trailer in ECBC Breeze Tunnel

A full scale trailer mounted version of JBPDS was placed in the ECBC Breeze tunnel facility. Wind tunnel testing of scale model indicates that tongue forward orientation is most likely to cause flow problems therefore all testing was performed with the trailer facing forward. This will be defined as the 12-o'clock position. (most photos depicted looking downstream at trailer) Flow over the trailer was visualized using a smoke wand and a theatrical smoke plume generator



Outside view of breeze tunnel

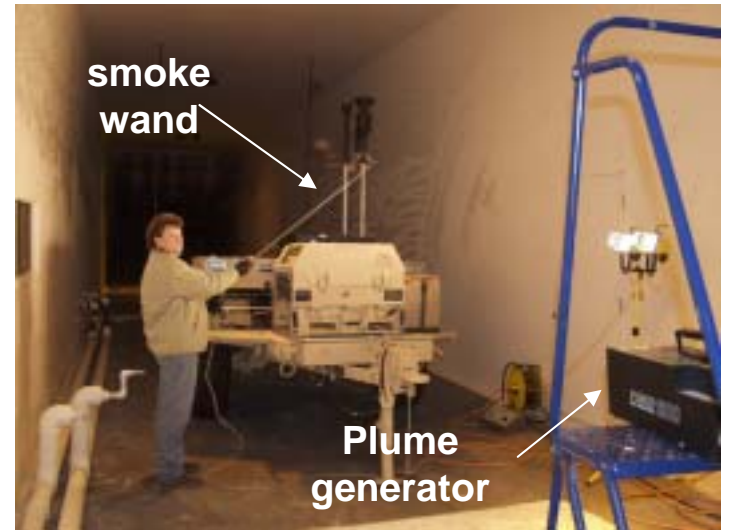

smoke wand

Plume generator

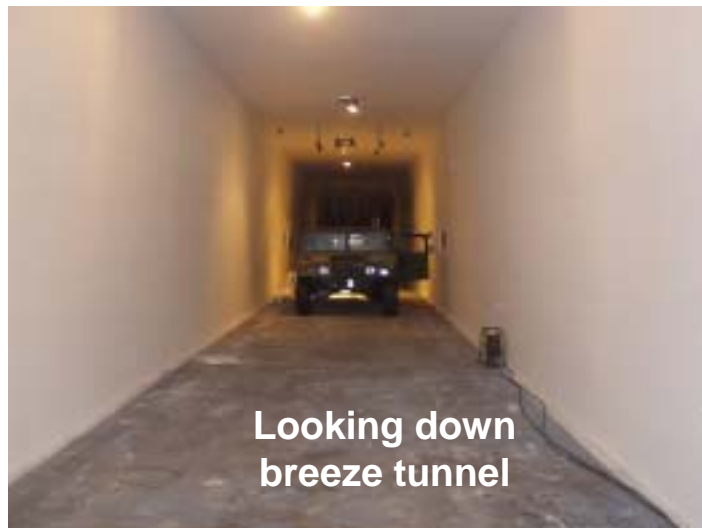

Looking down breeze tunnel

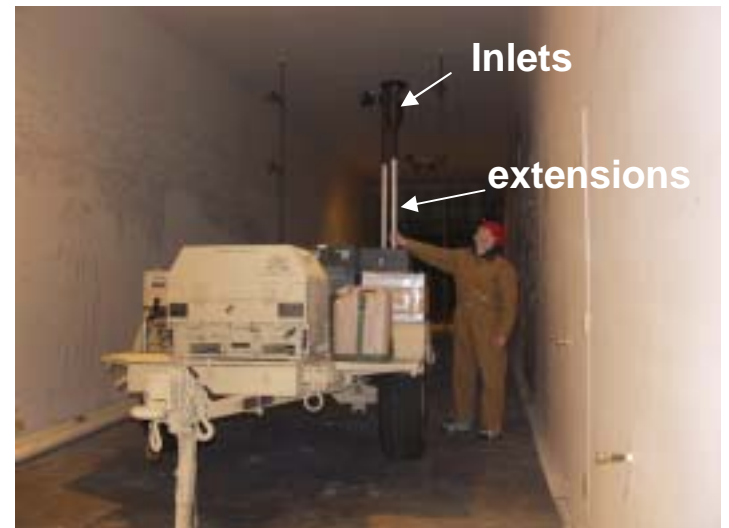

Inlets

extensions

Trailer Mounted JBPDS Flow Study

Flow visualization over actual trailer in ECBC Breeze Tunnel

Streamlines over blunt leading edge of trailer objects visualized using smoke wand. The two photos show the deflection of the flow up and over the blunt object and, as the wand is lowered, the height of the dead-air recirculation zone over the surface of the blunt object. This is useful to compare to the flow over the scale model in the wind tunnel testing.

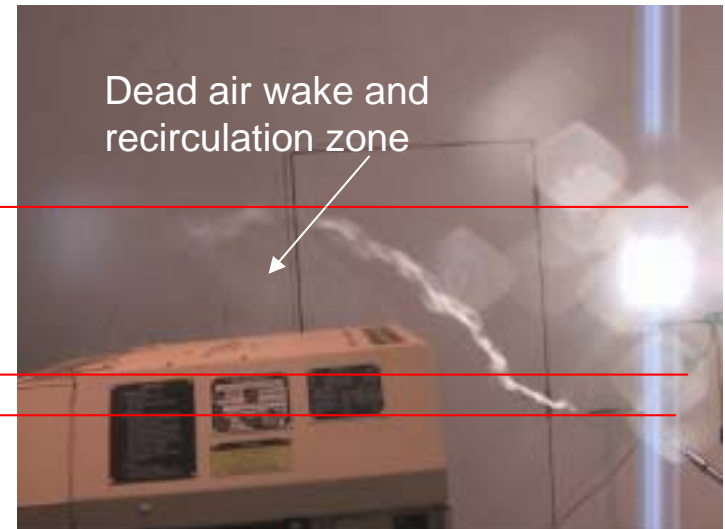
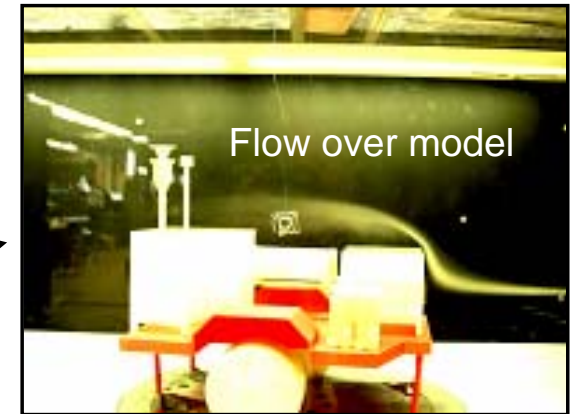

Trailer Mounted JBPDS Flow Study

Flow visualization over actual trailer in ECBC Breeze Tunnel

Smoke plume from a theatrical smoke generator is released upstream of trailer from a vertical height of 54-inches. Plume encounters blunt shape of trailer objects and rises. Plume passes inlet location at a height no greater than the maximum height of the inlet extensions. Intake of inlet is at least 24-inches above this flow field.

**Test conditions: T=40 F,
Wind Velocity ~ 6 mph**

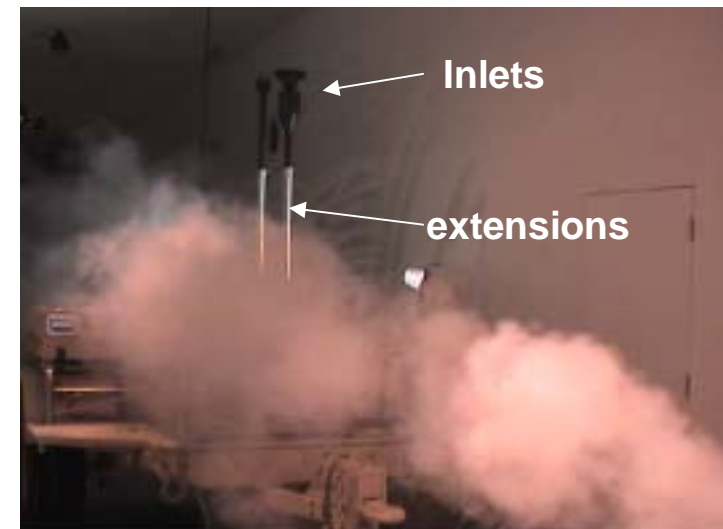



Part 2. Summary & Comments

Edgewood Chemical Biological Center

- Tests were conducted on 20% scale model in wind tunnel and actual full scale trailer mock-up in breeze tunnel. Good agreement between observations made in wind tunnel and breeze tunnel.
- Tests were conducted with and without camouflage netting draped over trailer.
 - *Without camouflage canopy:* the flow to the inlet intake area is fine, even without the inlet extensions in the worst case orientations. The trailer and mounted equipment has very little influence on effective sampling height.
 - *With camouflage canopy:* The flow to the inlet intake area is fine when extensions are used. Effective sampling height is about 8-inches lower than the actual inlet height due to streamline deflection upward to inlet as flow passes over canopy
 - Significant flow penetrates canopy, and accumulates under the netting. Some of the flow is pulled up through the top of the canopy and rolls along the net surface to the inlet site. Flow remains attached to top of canopy. If configured without inlet extensions it would still aspirate the target aerosol, however it would also probably take in a lot of contaminant from the trailer area, equipment and dust from the ground



Part 2. Summary & Comments

Edgewood Chemical Biological Center

Recommendations:

- Inlet extension use is recommended when the system is draped in camouflage.
- Inlet extension use is optional when the trailer is “uncloaked” or normally configured. Extension use would neither enhance nor adversely affect performance.



Conclusion

Flow fields around two JBPDS configurations were evaluated for pertinence to system performance. Used 3 techniques: models in wind tunnels, full scale hardware in breeze, and Computational Fluid Dynamics (CFD)

- Wind tunnel & scale models: good visualization, have to be aware of scaling effects
- Full scale: can evaluate effect of things that are tough to model (camouflage netting) but harder to perform visualization, need big test facility with quality air flow
- CFD: Great for detailing flow. Results depend on skill of the user, especially with fine detailing of flow. Can be a time-saver or a time-sink, for example the modeling of camouflage net could be a large study

Conclusion

Edgewood Chemical Biological Center

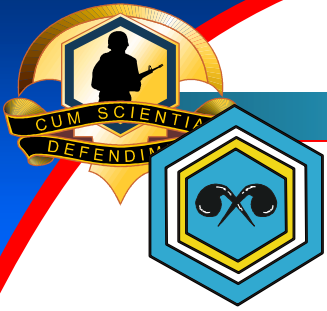

Flow field around nearby objects can affect detection system performance, this study observed various effects:

- Effective Sampling heights were identified
- Effects of cloaking nets were investigated
- Proximity to inlets to various flow fields were detailed, speculated on implications
reiteration of the main findings:
 - Inlet intakes could be in or on boundary of recirculation zones
 - May have effect on system due to fluctuating aerosol concentrations and trapping/bleeding of ground dust/background to intakes
 - Contaminants/ interferents/ dust/ exhaust downwind from system can be drawn back to system by reverse flow in wakes



Conclusion

Edgewood Chemical Biological Center

Main Point:

Be aware of the nature of the flow field around your sampler. You can then account for effect, mitigate the effect, or perhaps use it to advantage.