

**10<sup>TH</sup> INTERNATIONAL COMMAND AND CONTROL RESEARCH AND TECHNOLOGY  
SYMPOSIUM  
The Future of C2**

**Title of Paper:**

**Are DoD Network Centric Policies, Processes and Edge Organizations Sufficiently  
Adaptable to Adequately Respond to The Impact of Globalization?**

**Topic: Policy**

**Author: Jack Lenahan**

**POC: Jack Lenahan**

**Organization: Office of the Chief Engineer  
Space and NAVAL Warfare Systems Command  
Charleston, S.C.**

**Address: P.O. Box 190022**

**N. Charleston, South Carolina: 29419**

**Phone: 843-218-6060**

**Email: John.Lenahan@Navy.mil**

**Abstract**

Can the DoD adapt quickly enough to ensure that its current military edge is not eroded by globalization? Does unchecked globalization threaten to enable the mass proliferation of capability and weaponry including nano super weapons at the expense of the American warfighter? Force multiplication, increased awareness, better quality of data, improved decision making are all well known aspects of the benefits of net centrality. But does not increased globalization threaten to permit adversaries to exploit their own Network Centric Warfare (NCW) capabilities and also use more accessible GRID super-computational capabilities to accelerate advanced weapons systems development countering the U.S. advantage?

This research concludes that the U.S. DoD needs the ability to rapidly create policies in response to globalization created changes. Thus, in order to provide these capabilities, I recommend the rapid development of composable policy frameworks, policy semantics models, composable data warehouses, and intelligent policy analysis agents, in order to provide the policy assessment tools needed to support the adaptability and superior decisions required to succeed in a Post-international, globalist environment. Specifically the paper recommends policy assessment and simulation composable services targeting: Technical & Scientific Knowledge Base Maintenance, Globalization Impact Analysis for Mutual Defense Treaties, and Nano Weapon Defense Tactics Assessments and Simulations.

# Report Documentation Page

*Form Approved  
OMB No. 0704-0188*

Public reporting burden for the collection of information is estimated to average 1 hour per response, including the time for reviewing instructions, searching existing data sources, gathering and maintaining the data needed, and completing and reviewing the collection of information. Send comments regarding this burden estimate or any other aspect of this collection of information, including suggestions for reducing this burden, to Washington Headquarters Services, Directorate for Information Operations and Reports, 1215 Jefferson Davis Highway, Suite 1204, Arlington VA 22202-4302. Respondents should be aware that notwithstanding any other provision of law, no person shall be subject to a penalty for failing to comply with a collection of information if it does not display a currently valid OMB control number.

1. REPORT DATE <b>2005</b>		2. REPORT TYPE		3. DATES COVERED <b>00-00-2005 to 00-00-2005</b>	
4. TITLE AND SUBTITLE <b>Are DoD Network Centric Policies, Processes and Edge Organizations Sufficiently Adaptable to Adequately Respond to the Impact of Globalization?</b>				5a. CONTRACT NUMBER	
				5b. GRANT NUMBER	
				5c. PROGRAM ELEMENT NUMBER	
6. AUTHOR(S)				5d. PROJECT NUMBER	
				5e. TASK NUMBER	
				5f. WORK UNIT NUMBER	
7. PERFORMING ORGANIZATION NAME(S) AND ADDRESS(ES) <b>Space and Naval Warfare Systems Command, PO Box 190022, North Charleston, SC, 29419</b>				8. PERFORMING ORGANIZATION REPORT NUMBER	
9. SPONSORING/MONITORING AGENCY NAME(S) AND ADDRESS(ES)				10. SPONSOR/MONITOR'S ACRONYM(S)	
				11. SPONSOR/MONITOR'S REPORT NUMBER(S)	
12. DISTRIBUTION/AVAILABILITY STATEMENT <b>Approved for public release; distribution unlimited</b>					
13. SUPPLEMENTARY NOTES <b>The original document contains color images.</b>					
14. ABSTRACT					
15. SUBJECT TERMS					
16. SECURITY CLASSIFICATION OF:			17. LIMITATION OF ABSTRACT	18. NUMBER OF PAGES <b>17</b>	19a. NAME OF RESPONSIBLE PERSON
a. REPORT <b>unclassified</b>	b. ABSTRACT <b>unclassified</b>	c. THIS PAGE <b>unclassified</b>			

## **Introduction**

Globalization appears to be eroding the technology “time to capability gap” that our adversaries have traditionally had to close to gain parity. Can the DoD adapt quickly enough to ensure that its current military edge is not eroded by globalization? Does unchecked globalization threaten to enable the mass proliferation of capability and weaponry including nano super weapons at the expense of the American warfighter? Force multiplication, increased awareness, better quality of data, improved decision making are all well known aspects of the benefits of net centricity. But does not increased globalization threaten to permit adversaries to exploit their own Network Centric Warfare (NCW) capabilities and also use more accessible GRID super-computational capabilities to accelerate advanced weapons systems development countering the U.S. advantage? Does globalization appear to be leading to a greater proliferation of weaponry at all levels? Does a possible “increase in the disappearance of borders” threaten the efficacy of existing alliances? The purpose of this paper is to address these issues.

In particular there are two aspects of globalization which may present significant risks to the American Warfighter: increased network access may enable our adversaries to build NCW clones; second increased knowledge transfer and access to advanced GRID computational resources may accelerate enemy advances in so called “nano super weapons”. Let us all recall Drexler’s warning<sup>1</sup>: “Replicating assemblers and thinking machines pose basic threats to people and to life on earth. Today’s organisms have abilities far from the limits of the possible, and our machines are evolving faster than we are. Within a few decades they seem likely to surpass us. Unless we learn to live with them in safety, our future will likely be exciting and short.”

### **A few quotes from the RAND Corporation’s relevant research**

In similar research related to this discussion, the Air Force has identified several globalization concerns in the definitive RAND Study. Particularly: “How are legitimate security of supply, technology transfer, and other technology security issues being handled, particularly in the new multipolar, multinational business environment?”

The RAND<sup>2</sup> study makes several key points:

“A review of DoD and Air Force policy documents identifies three overarching objectives that motivate Air Force concerns about globalization of the defense aerospace industrial base:

1. The need to equip aerospace forces with affordable yet highly capable weapon systems, both today and in the future (the economic and technological dimension);
2. The need to prepare the United States, its allies, and other friends to fight future wars as coalitions (the political-military dimension); and
3. The need to protect U.S. national security (the national security dimension)”.

### **Adversary Network Centric Capabilities**

One of the RAND studies major conclusions is “With respect to national security, ongoing economic integration may make it harder to control the spread of weapons and technology beyond our borders and those of our allies.”

I concur wholeheartedly with this research. It follows logically that “NCW like” capabilities can be quickly assembled by potential adversaries with the continued access to network and GRID computing resources made available by globalization. Globalized network assets and capabilities will permit adversaries to exploit much of the work being accomplished by DoD transformation efforts. Thus a potential adversary may have situational awareness, data access, and decentralization capabilities equivalent or close to the U.S. forces’ capabilities.

### **Adversarial Exploitation of U.S. Assets Particularly through the use of Brokered Services in the form of GRID Computational Resources**

The other component that I would like to emphasize concerning globalization is the ease of access to super computing assets primarily enmeshed in GRIDS. The ability to submit complex and computationally intensive tasks (missile dynamics analysis, bio weapons design, molecular models needed for nano weapons research, aircraft aerodynamic design and analysis tasks for example), circumvents older trade policies which used to block sales of CRAY supercomputers and other high end technology assets to potential adversaries. The reason for those earlier trade policies was to slow down development of adversarial capabilities which may put our Armed Forces at risk. Globalization enabled, publicly available composeable GRID computation services, seem to put an end to the ability of the U.S. military to stay technically superior to any adversary very long. Longer delivery times of adversary aircraft and other high tech war fighting capabilities can now be reduced by globalization enabled web service based access to sophisticated computational capabilities, provided as brokered services by major U.S. technology companies.

### **Supply Chain Vulnerability**

The continual outsourcing of critical systems development to firms with no loyalty to the US is a direct threat to our security. There must be boundaries established which make sense in terms of defending the key economic infrastructure segments from continual business architecture decomposition, the risk being that the supply chain will become so complex and delicate, that terrorist interruption of that supply chain is made easier, not more difficult.

### **Globalization General Discussion**

If globalization occurred only between freedom loving democracies, this paper would be unnecessary. But since we are talking about technology development outsourcing, and the de-Americanization and transfer of U.S. based corporate financial assets and technology regardless of the partner regime type, then the DoD must devise policies and capabilities to counter the possible loss of capability edge due to globalization. Given that globalization is enhanced by the ease of availability of the internet, mobile communication, web browsers in cell phones, etc., we can easily infer that the enemy is also able to exploit NCW possibilities courtesy of the phenomenon of globalization.

## Analysis of Business Architecture Modeling

The graphic below depicts a traditional business model. Just to start at a conceptually simple place, I have lines drawn in between each business unit to depict “interfaces”.

### Traditional Corporate Business Architecture

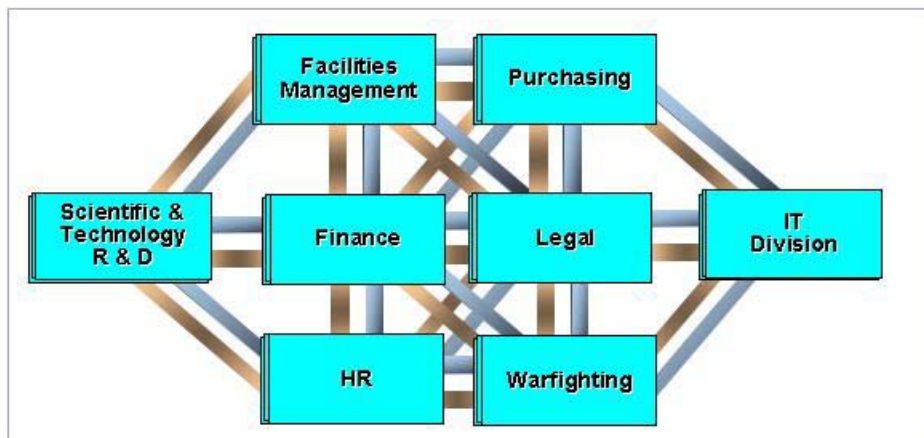

**Figure 1 – Simple Business Architecture Model**

Prior to the 1950's, the interfaces were paper communications, and personal or phone communications. Soon these interfaces became computer enabled with the advent of Electronic Data Interchange (EDI) business communication standardization designs. By defining many business transaction types electronically, businesses saved money, better served customers, and streamlined operations (needing fewer people). But it became obvious to many students of business architectures (structures with physical and electronic interfaces between the business units), that the individual business units no longer needed to be physically co-located. It was also obvious that each individual business unit could now be “rated” as to its profitability, product quality, and efficiency. Given a well defined interface set between the units, if a particular unit was losing money or had poor quality output, the design of the business architecture permitted easy replacement of the deficient module (business unit). For example, if your payroll department made a lot of mistakes and also lost money every quarter, a business designed in a modular fashion could contract payroll to another firm and simply “plug in” the outsourced company's interfaces at a lower cost. Sounds good so far, but perhaps a closer look may reveal a few interesting aspects of this process which have defense department implications. What exactly is “outsourced”? It happens to be the case that the new payroll

providing company in our example above probably will not work for free. Money must be transferred from the contracting company to the contractor. So capital has begun to move or flow out of the parent. While the parent probably is saving costs and lowering overhead, cash is flowing out regardless.

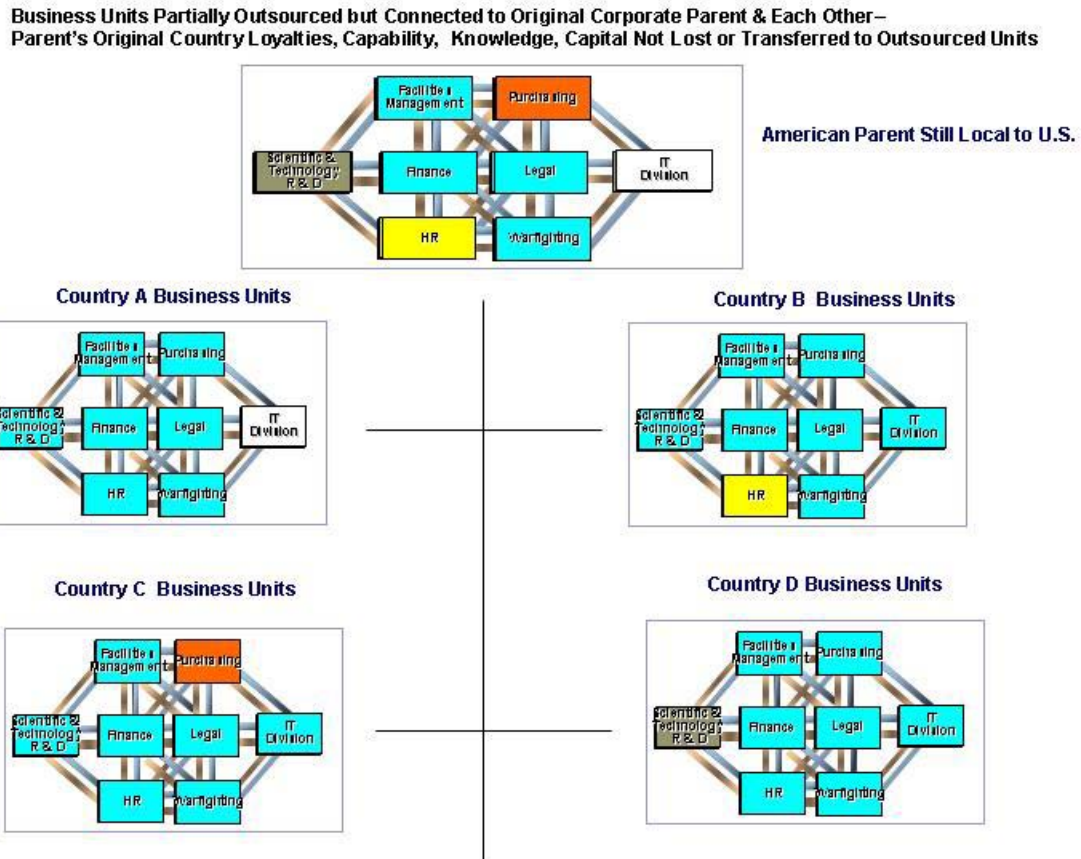

**Figure 2 – Foreign Business Unit Outsource Model**

If the parent company were to buy the payroll company, it would still own the capital even if the outsourced units were to be created in foreign countries as depicted above. This model while outsourced, still permits total or major control of capital and other corporate assets. The profits and further expenditures of capital are just as likely to occur in the U.S. as elsewhere. But by definition, in this model, some of the financial assets of the parent would be left in the outsourced country. Let’s now substitute defense related software development or chip manufacturing instead of payroll. Now not just business units are outsourced but small “clones” of the entire parent begin to appear in the outsourced nations. This now transfers both capital and business knowledge not to mention key technical knowledge, particularly if the corporation’s headquarters moves out of the U.S. If a certain degree of independence is granted to the outsource country business units, why can’t they outsource some of their own work to cheaper local companies?

**Business Units Totally Outsourced & Disconnected from Original Corporate Parent & Each Other – Parent’s Original Country Loyalties, Capability, Knowledge, Capital Lost or Transferred to Outsourced Units**

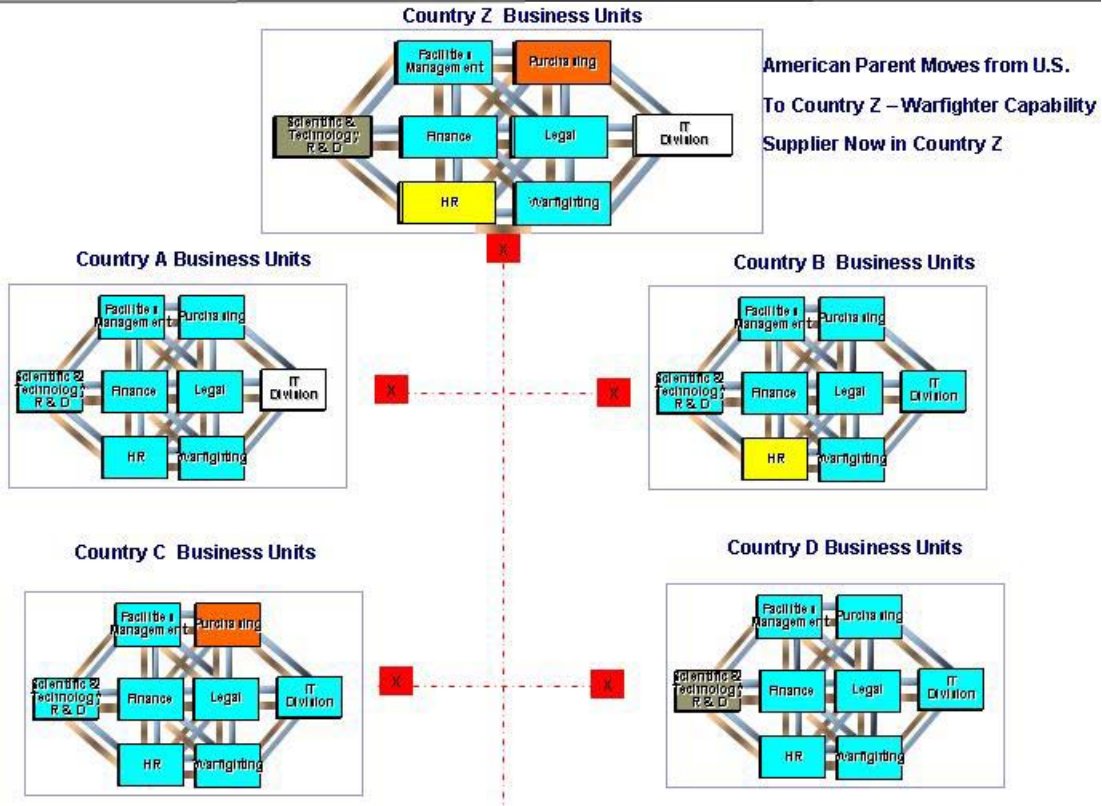

**Figure 3 – The decentralized outsourced units gain their independence from the original parent**

Thus, we begin again always in search of the absolute minimum cost per business unit which of course is \$zero. If this process is executed by a significant number of U.S. companies, net capital and trade flows would seem to trend against financial assets staying in the U.S. The usual counter to this argument is that “what will these new workers do with their new wages? Buy American of course!” Maybe, or maybe not, such a simplistic answer seems to collapse in the face of cheaper foreign goods or fluctuating U.S. currency. Now let us proceed to the next level of decentralization. Once the second tier outsource companies figure out the game, they too begin to outsource to cheaper and theoretically higher quality suppliers. The process is again repeated until you arrive at the next graphic.

Original Outsourced Business Units Initiate Secondary Outsourcing. Eventually Disconnecting from the Secondary Parent & Each Other – Internal Nation State Dissolves Into Multiple Provincial Independent Political & Military Entities – Old Borders Begin To Effectively Disappear and Their Alliances With Them

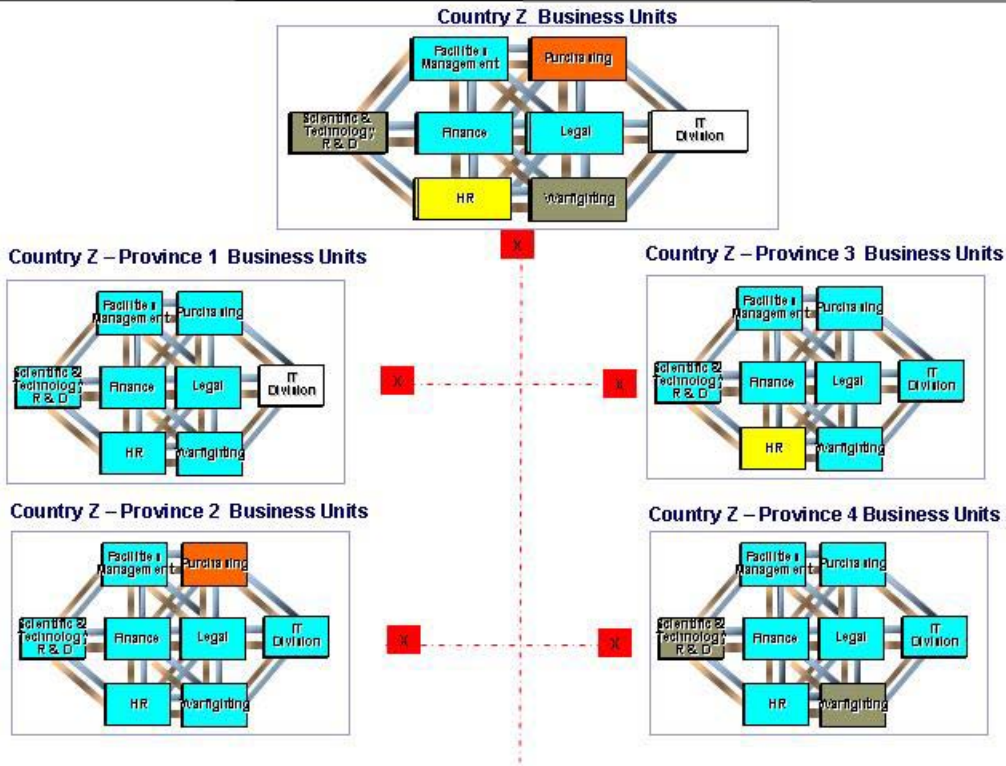

**Figure 4 – The beginning of the formation of new & more powerful local economic units**

As the figure above shows, the outsourcing has now trickled down to a province level. Suddenly, capital is available in steady stream which did not exist before. Taxes can now be increased and the government can now spend more money on defense. They also have greater technical skills since they must maintain their educational base in order to achieve a superior technical and cost advantage. Thus capital and knowledge have now transferred to a country which may be a potential future adversary or a potential technology supplier to one of our adversaries. What if they do not wish to pay a lot of taxes but instead opt to form a local economic alliance or mutual defense agreements and secede from the original parent nation state? Sound far fetched? Let me quote from a nice piece of relevant research. In a work entitled “END OF THE NATION STATE: The Rise of Regional Economies”<sup>3</sup>, by Kenichi Ohmae, the following is stated: “Is the state a viable” business unit” in the new globalized world?” What are the implications for US military policy if more borders begin to effectively disappear? This in reference to the following analysis and quotation:” Traditional nation-states have become unnatural, even impossible business units in a global economy” This is known as post-nationalism or post internationalism. This is the belief that continued globalization will lead to the effective dissolution of today’s nation states. **What are the policy implications of this if it happens, in terms of treaties and coalition formation?**

In my opinion, NCW rapidly composable processes, organizations, assessments, simulations, pooled asset management, and warfighting capabilities offers the best chance

at minimizing the impact of globalization on the U.S. warfighter. This author believes that a policy modeling and simulation tool kit is needed to model various alternative policies and possible or potential capital flow or capital outlay restrictions on certain key U.S. firms with a significant DoD procurement supplier role. The tool would also need to be able to “compose new edge organizations and alliances” made up of possibly hundreds or thousands of small economic self interest based post-internationalist sub states.

**Policy Domain Simulation Tools**

Simulating the policy domain has been researched at some level of depth by Dr. Raymond Paul and Jay Bayne and was presented to this body last year<sup>4</sup>. I believe that this research aligns well to the issues being addressed in this paper and a discussion of their work follows. The model below depicts the basic schematic of a VPU.

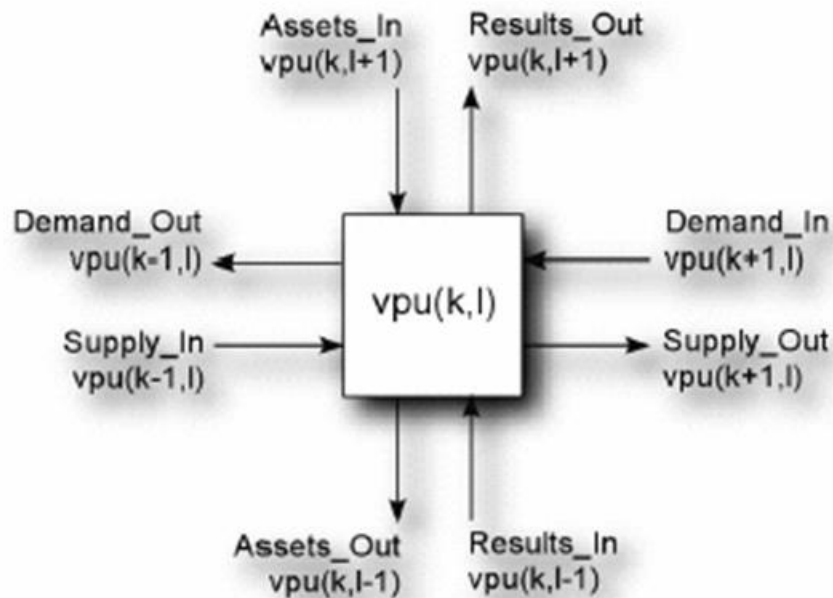

**Figure 5 – Value Production Model Schematic**

Their notion of a Value Production Unit or VPU as the basis for determining asset flow seems to be of paramount relevance to my paper’s topic. A VPU<sup>5</sup> according to Bayne, is described as “Products are created, produced, and maintained by value production units. VPUs are dynamic, semi-autonomous logical entities that simultaneously serve two independent value chains:

- An asset chain where investors purchase equity in VPUs in exchange for gains from higher valuations resulting from increased production capacity or product capability, and
- A supply chain where producers and consumer trade in goods and services.

A Value Production unit is also described by Bayne and Paul as “The locus of enterprise management activity responsible for production of a quantifiable measure of value is referred to as a *value production unit* (VPU). A VPU is an abstract object that participates in *production webs* with other VPUs, (a set of VPUs is a web value chain - JL), which are bound by *value chains*, specifically a vertical *asset chain* and a horizontal *supply chain*.

Value Chain	Port ID	Port Name	Port Function
Asset Chain	$a_i$	Assets In	Acceptance and assimilation, according to a service-level agreement (SLA), of allocated assets from superior VPUs
	$r_o$	Returns Out	Production of returns on value produced by previously allocated assets; requests for allocation of additional assets
	$a_o$	Assets Out	Allocation, based on a SLA, of assets to subordinate VPUs with expectations for a minimum time-specific return of value for the allocation
	$r_i$	Returns In	Acceptance and assimilation of returns and evaluation of requests for asset allocations from subordinate VPUs
Supply Chain	$d_i$	Demand In	Acceptance of demands (orders) for goods or services from upstream consumer (client) VPUs
	$s_o$	Supply Out	Fulfillment of demand (orders) in the form of goods or services to downstream consumer (client) VPUs
	$d_o$	Demand Out	Issuance of demands (orders) for goods or services to upstream producer (server) VPUs
	$s_i$	Supply In	Acceptance of fulfilled orders for goods or services from downstream producer (server) VPUs

**Table 1 – VPU Input & Output Term Definitions**

...VPU[k,l] identifies a value production process at the “l<sup>th</sup>” level in an asset chain and the “k<sup>th</sup>” position in a supply chain. VPU[k,l] is *subordinate*, and therefore accountable to, VPU[k,l+1] in the asset chain, and a *server* or service provider, and therefore committed to, VPU[k+1, l] in the supply chain. “Likewise, VPU[k,l] is a *superior* to, and therefore responsible for, VPU[k,l-1] in the asset chain, and a *client* of, and therefore dependent on, VPU[k-1,l] in the supply chain. “

“The difference between fully burdened value production costs and domain clearing prices, measured in the domain’s economic units, equals the marginal benefit (profit) realized by the enterprise in the continuous evaluation (execution) its value propositions. An enterprise is viable to the extent this marginal benefit is both sustainable and sufficient to fuel adaptation within its competitive environment. In other words, A viable enterprise is a computational object (virtual machine) that continuously executes a finite set of adaptive programs (its value propositions) whose results provide marginal benefits sufficient to 1) satisfy its evolving market requirements and 2) fuel internal innovations sufficient to maintain homeostasis.”

By modeling the existing Multi-national corporations business units in Dr Paul’s VPU model, it should be possible to develop algorithms capable of driving simulations to predict the possible complexities of a post internationalist world should it emerge and prove the theorists correct. Dr. Paul’s work also introduced the notion of a Policy Execution Framework (PEF), which is a software framework containing tools and services to be used to assist policy analysts and formulators. Composeable organizations and processes will become a primary feature of the new Globalism. If decentralized

governments appear as a result of protecting smaller and smaller economic units, which may signal the end of the nation state, what flexibility does the U.S. have in terms of coalition formation if the governance units shrink in size? What happens to treaties? What happens if a country containing large U.S. corporate outsources investments threatens to nationalize the assets and disrupt the parent companies financial condition? I am recommending that the globalization issue can be strongly modeled with VPU's and the PEF to simulate and manage 100s or possible thousands of alliance members due to a worst case globalization impact. By this I mean a worst case polity structures issue with the sudden appearance of small economic encapsulations or political units, particularly with respect to the modeling of the safety of the supply chain of key military capabilities.

The following VPU based graphics set is intended to depict two major points: the variety of ways that globalization and outsourcing can impact supply chain fragility and the potential for asset outflows to occur during outsourcing. The figure below depicts a U.S. manufacturing company with all assets located in one building, each business unit has well defined interfaces with all the other business units including asset flow, demand flows, and supply flows. Each unit is depicted as a VPU, since if a unit creates no value or supplies no value to the parent company, it can easily be discarded or outsourced or not exist in the first place.

**US based Manufacturing Company - All Assets & All Departments in One Building, in One Physical Location – But with well defined interfaces between each departmental unit**

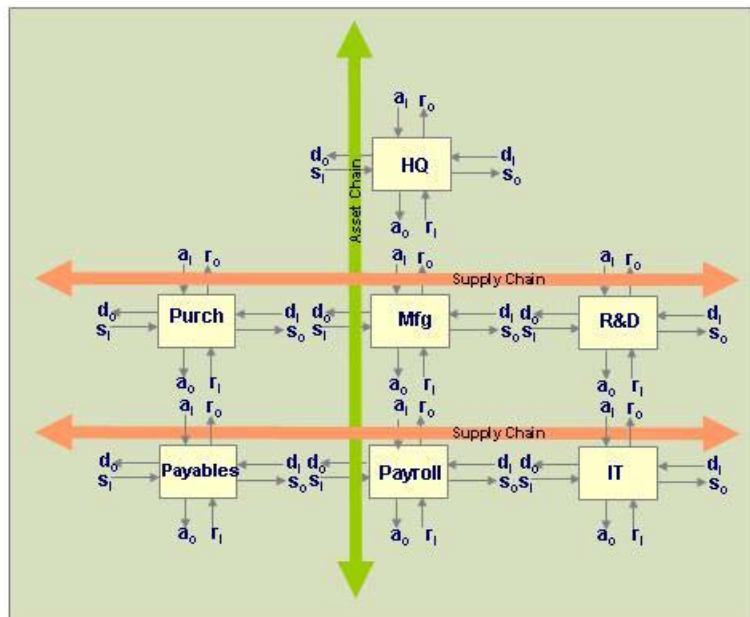
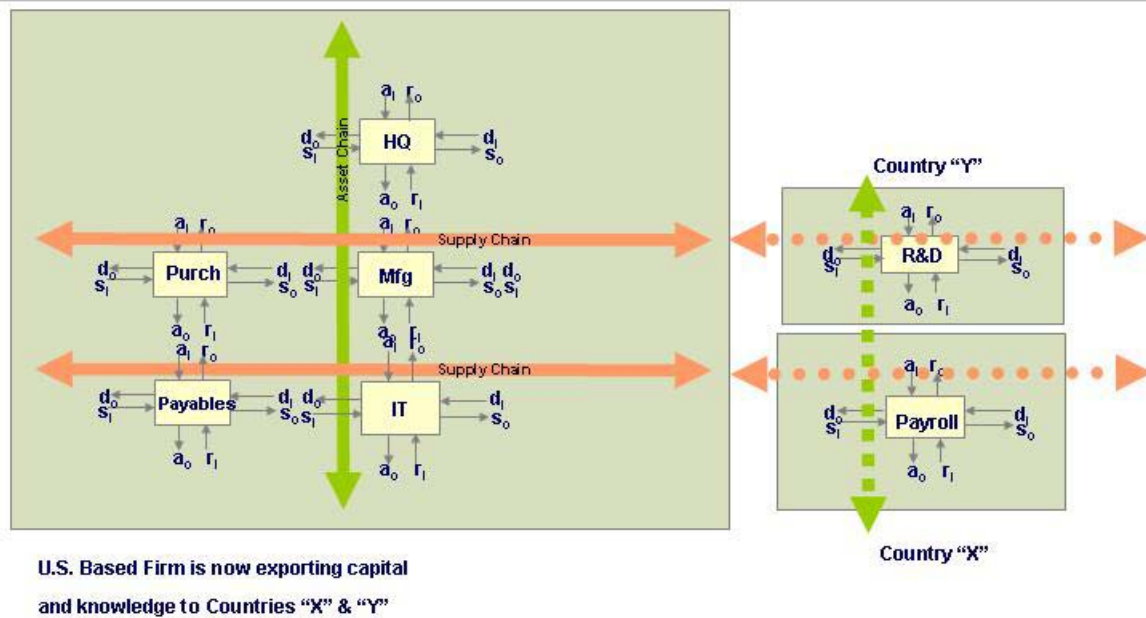

**Figure 6 – Value Web Depiction of a Corporate Entity**

Supply chain fragility in the above model is low since the business exists on U.S. soil and is self contained. Asset flow is also internal only. But what happens if one of the units becomes unprofitable or another company can provide a cheaper and quality equivalent capability?

The figure below depicts that case. R&D and Payroll have been determined to be of a better quality and or cheaper in different countries.

**U.S. Manufacturing Company - With well defined interfaces between each departmental unit but with Payroll & R&D outsourced to a cheaper companies outside the U.S. This improves cost performance but company has lost payroll capability & R&D Knowledge Control . If outsource companies are in foreign countries "X" & "Y", then "X" & "Y" enjoy new asset flows plus "Y" gains scientific knowledge and access to parents IT infrastructure.**



**Figure 7 – Simple Outsourcing Model Using VPUs**

The parent decides to move the two business units abroad. The result is that assets and supply now exhibit flow conditions not present in the case in the original self contained model. Let's suppose though that U.S. security is not an issue for this company and that they decide to really maximize their profits by outsourcing more of the original business units. The graphic below depicts such a condition or situation. But the outsourced country's company has now figured out the profit maximization game and is now outsourcing themselves. They also have differing alliance and historical ties to certain countries than the parent U.S. Corporation does and so form knowledge transfer partnerships with their "friends". If any of these "partners" with the outsourced country become U.S. adversaries, we have by definition weakened our supply chain.

U.S. Manufacturing Company reduces costs drastically by outsourcing all unprofitable business units, maximizing profits. Countries "X" & "Y" now have won sufficient outsourcing contracts to form their own large corporations which in turn outsource to internal provinces. Being closed, undemocratic states they form closed mutual knowledge transfer partnerships to benefit each other's weapons development programs with the profits from the outsourced initiatives. Work & Capital are now dispersed to previously poor provinces enabling them to merge rapidly as internally competing economic units which may eventually request autonomy.

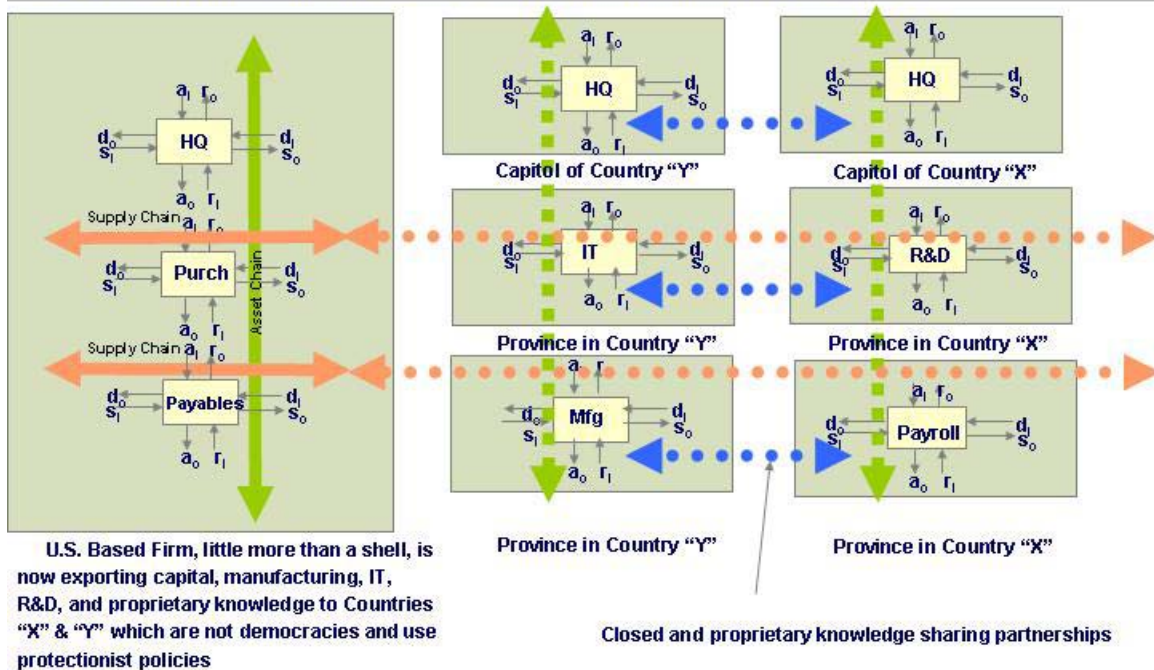

Figure 8 – Model Depicting Substantial Outsourcing and Asset Outflow from the U.S.

The result of this section of the analysis concludes that U.S. military policy makers and planners cannot ignore the supply chain fragility caused by the impacts of globalization.

### Nano Super Weapons Discussion

What impact will the smaller political units cause? The U.S. may for the first time in its history, face hundreds or thousands of potential enemies and not just a few. But you say "so what: they will be small", small but deadly if they possess super weapons. This gives rise to the second and more daunting issue for policy makers: the possible appearance of nano super weapons. The supply chain fragility issue is why I am proposing that Bayne - Paul analysis be given serious consideration for immediate development. Next, the advanced weapons systems development issue is why I am proposing that DoD assessment toolkits be expanded to provide solutions and tactics for defending U.S. military assets against self replicating assembler weapons. But before I am dismissed as another "Chicken Little", I would like to provide a few quotes from a few famous individuals.

"I think it is no exaggeration to say we are on the cusp of the further perfection of extreme evil, an evil whose possibility spreads well beyond that which weapons of mass

destruction bequeathed to the nation-states, on to a surprising and terrible empowerment of extreme individuals."

Bill Joy, co-founder of Sun Microsystems, April 2000

"Given the potential scale of devastation brought into view by nanotechnology, it is tempting to move beyond the designation weapons of mass destruction and coin a new phrase - weapons of global destruction (WGD)"...

Sean Howard<sup>6</sup>, proposer of the "Inner Space treaty"

"The problem, though, is what if a nano-assembler's programming went awry! Instead of building what we wanted it to build and then shutting down or going into maintenance mode, suppose that it and its progeny continued savaging the atomic material around them to build an unchecked swarm of nano-assemblers, which in turn build more nano-assemblers, ad nauseam. Consider that if these nano-assemblers have the ability to build nano-things, then they must necessarily also have the ability to UN-build the things around them as they mine atomic resources to feed their now out-of-control project! "

"This is the "gray goo" scenario previously popularized by Bill Joy ([http://www.wired.com/wired/archive/8.04/joy\\_pr.html](http://www.wired.com/wired/archive/8.04/joy_pr.html)) and by several science fiction writers, and which is being explored in some new detail by Sean Howard<sup>7</sup> in the August "Acronym Institute" article "Nanotechnology and Mass Destruction: The Need for an Inner Space Treaty" (<http://www.acronym.org.uk/dd/dd65/65op1.htm>). He sums up the issue, while pointing out that nano-accidents aren't the only consideration."

"Processes of [nano] self-replication, self-repair and self-assembly are an important goal of mainstream nanotechnological research. [But] either accidentally or by design, precisely such processes could act to rapidly and drastically alter environments, structures and living beings from within. In extremis, such alteration could develop into a 'doomsday scenario', the nanotechnological equivalent of a nuclear chain-reaction - an uncontrollable, exponential, self-replicating proliferation of 'nanodevices' chewing up the atmosphere, poisoning the oceans, etc. "

"The Harrow Technology Report The Ultimate Tool? Sept. 9, 2002 "

### **Is anyone really trying to build these classes of weapons?**

More from San Howard's article

"The Massachusetts Institute of Technology plans to create military uniforms that can block out biological weapons and even heal their wearers as part of a five-year contract to develop nanotechnology applications for soldiers, the US Army announced... MIT won the \$50 million contract to create an Institute for Soldier Nanotechnologies, or ISN. The ISN will be staffed by around 150 people, including 35 MIT professors... The unique lightweight materials that can be composed using nanotechnology will possess revolutionary qualities that MIT says will help it make a molecular 'exoskeleton' for soldiers. The ISN plans to research ideas for a soft - and almost invisible - clothing that can solidify into a medical cast when a soldier is injured or a 'forearm karate glove' for combat, MIT said. Researchers also hope to develop a kind of molecular chain mail that can deflect bullets. In addition to protecting soldiers, these radically different materials

will have uses in offensive tactics, at least psychologically. 'Imagine the psychological impact upon a foe when encountering squads of seemingly invincible warriors protected by armour and endowed with superhuman capabilities, such as the ability to leap over 20-foot walls,' ISN director Ned Thomas said in a release."

This is good news for our soldiers so long as globalization does not permit the appearance of the above cited new nano warfighter capabilities protecting the soldiers of our adversaries first. But what are the other guys doing? Does anyone suspect that another military power may be examining or attempting these capabilities? By using the West's capital and knowledge assets to enable weapons, globalization may be enabling our adversaries. The following quote indicates a possible worst case exploitation of Globalism. Citing Lev Navrozov<sup>8</sup>:

"Isak Baldwin, manager of our not-for-profit Center for the Survival of Western Democracies, Inc., has sent me a BBC News Web site report of February 10, 2005...."

"China's annual surplus in Sino-American trade reached in 2004 an astronomical sum: \$162 billion, "the largest ever recorded with a single country."

Note that "the supreme leaders" of China do not need the approval of any legislature to lump all of the \$162 billion into the development in 2005 of molecular nanoweapons, predicted by Drexler in Chapter 11 of his book of 1986, or of other post-nuclear superweapons, or of all of them, to see which of them is able to deliver the fatal blow to the West by destroying its means of (nuclear) retaliation, thus circumventing Mutual Assured Destruction and making the West defenseless".

**But now, Drexler moves away a little but not totally<sup>9</sup>; quoting directly from Drexler & Phoenix:**

**“Abstract.** In 1959, Richard Feynman pointed out that nanometre-scale machines could be built and operated, and that the precision inherent in molecular construction would make it easy to build multiple identical copies. This raised the possibility of exponential manufacturing, in which production systems could rapidly and cheaply increase their productive capacity, which in turn suggested the possibility of destructive runaway self-replication. Early proposals for artificial nanomachinery focused on small self-replicating machines, discussing their potential productivity and their potential destructiveness if abused. In the light of controversy regarding scenarios based on runaway replication (so-called 'grey goo'), a review of current thinking regarding nanotechnology-based manufacturing is in order. Nanotechnology-based fabrication can be thoroughly non-biological and inherently safe: such systems need have no ability to move about, use natural resources, or undergo incremental mutation. Moreover, self-replication is unnecessary: the development and use of highly productive systems of nanomachinery (nanofactories) need not involve the construction of autonomous self-replicating nanomachines. Accordingly, the construction of anything resembling a dangerous self-replicating nanomachine can and should be prohibited. Although advanced nanotechnologies could (with great difficulty and little incentive) be used to build such devices, other concerns present greater problems. Since weapon systems will be both easier to build and more likely to draw investment, the potential for dangerous systems is best considered in the context of military competition and arms control.”

**So where does this leave the focus of this discussion?**

It should be clear that self replicating assemblers are still possible and according to Drexler's own attempt at a retraction, are still in the military domain. But this is still the issue for this research. We cannot simply afford to place an issue of this magnitude in the hands of the negotiators and hope that nothing happens. The DoD must plan as if these weapon types will emerge sooner rather than later and develop appropriate tactics and defense systems to counter the new emerging threats. The DoD must have the capability to assess mission impacts in conflicts where the adversary possesses these new capabilities.

This author is still recommending that DoD tactics and assessment techniques be developed for the possibility of nano super weapons. The genie is out of the bottle, why place our country and armed forces at risk until we know for sure that a "No Nano Weapons Treaty" can be negotiated and enforced.

It will be necessary to focus R&D, intelligence, and software development assets in these areas until we can adequately defend against such threats. Thus, the following tool recommendations include a warfighting capability predictive ability which will assess adversarial capabilities in the broad field of nano weaponry.

### **Tools Recommendation**

I am proposing that a multi-layered, Meta Agent Based Architecture enabled by an SOA, provide the following services:

1. Predictive Capability Agents
  - i. Scientific Capability by Country
  - ii. Technological Capability By country
  - iii. New Weapons deployment by Country
  - iv. Terrorist exploitation of existing and predicted U.S. corporate globalization initiatives
2. Globalization Impact Predictive Agents
  - i. Supply Chain fragility analysis due to outsourced capability
  - ii. Treaty Adherence probability due to a potential disappearing border
3. Continuous Data Mining with results & discoveries published by COI

### **Tools Discussion**

The Meta Agents identified above will be used to dynamically create the reports and execute the data mining tasks required to fulfill their purposes. The Meta agents will call registered agents or create new agents as required. This architecture is a modification of the Composeable Data Warehouse model that I have proposed in a companion<sup>10</sup> paper created for this conference. The process composition architecture layer will use BPEL like orchestration, workflow, and choreography engines to drive the creation of the process steps needed to satisfy the requirements imposed by the Meta Agents. For example, suppose that the "Supply Chain Fragility Meta Agent" requested a report on its owner's behalf for an analysis of the stability of chip supplies to the DoD, if INTEL were thinking of moving totally offshore. The agent would need to construct a VPU web for INTEL, evaluate the risk of various locations of the impacted business units, and compute the supply chain risk by predicting the defensibility of the new supply chain as compared to the old supply chain. The agent would also need to discover the required

data sources, compose a warehouse on the fly, execute composed queries and data mining processes and create the final report and publish it to the users

To communicate between the agents, I am recommending that a Policy Specification Language, similar to the Bayne's – Paul efforts presented at last year's CCRP conference. Quoting from their work:

“Some of benefits of employing policy specification languages to implement a policy-handling system are: • Policy specification languages enable policies to be defined, independent from a concrete system implementation. • Policy specification languages are to be interpreted by a policy engine at runtime, which makes dynamical policy changes possible. • Policy specification languages formalize the intent of the controller into a form that can be read and interpreted by systems. • Policy specification languages are high-level languages, which makes it easy to learn and use by policy makers ...”

## Results

During the collapse of the former Soviet Union, many wondered if part of the atomic weapons stockpile had accidentally transferred into the hands of stateless terrorists. Will not globalization if unchecked at least for defense policy purposes lead to a more widened spread of weaponry at all levels?

The paper recommends the creation of composable policy assessment and simulation services targeting the following:

1. Technical & Scientific Knowledge base maintenance (Multi-variable optimization), using the VPU
2. Defense policy to plan for the defense of already fragile globalized supply chains
3. Globalization impact analysis for treaties
4. Nano weapon defense tactics assessments and simulations.

## References and Relevant Research

1. “Engines of Creation: The Coming Era of Nanotechnology” – Chapter 11: “Engines of Destruction”, K. Eric Drexler, Anchor Books Division of Random House, 1986
2. Going Global – U.S. Government Policy and the Defense Aerospace Industry, Lorell, Mark, A, Lowell, Julia, et.al., RAND Project Air Force
3. END OF THE NATION STATE : The Rise of Regional Economies, Kenichi Ohmae
4. Engineering Model For Enterprise Command and Control, Paul, Raymond PhD, OASD/NII and Bayne, Jay Echelon 4 Corp, 2004 CCRP Conference Paper
5. “A Software Architecture for Control of Value Production in Federated Systems” – Jay Bayne - Echelon 4 LLC
6. Nanotechnology and Mass Destruction: The Need for an Inner Space Treaty - source - Disarmament Diplomacy, Issue No. 65, July - August 2002 - web site <http://www.acronym.org.uk/dd/dd65/65op1.htm> , Opinion & Analysis By Sean Howard

7. “Opinion & Analysis: Nanotechnology and Mass Destruction: The Need for an “Inner Space Treaty”” ; By Sean Howard, “Disarmament Diplomacy” Issue No. 65, July - August 2002 - web site <http://www.acronym.org.uk/dd/dd65/65op1.htm>
8. “\$162 Billion From USA to China in 2004!”, by Lev Navrozov, Source: Newsmax.com, Friday, Feb. 18, 2005
9. “Safe exponential manufacturing”, by Chris Phoenix<sup>1</sup> and Eric Drexler<sup>2</sup>  
<sup>1</sup> Center for Responsible Nanotechnology, Brooklyn, NY 11238, USA  
<sup>2</sup> Foresight Institute, Los Altos, CA 94022, USA, Received 6 April 2004, Published 9 June 2004 -  
Source: <http://www.iop.org/EJ/abstract/0957-4484/15/8/001/>
10. “The Data Warehouse in Service Oriented Architectures and Network Centric Warfare”, Lenahan Jack, ICCRTS 2005
11. Policy definition from dictionary.com
12. Globalization definition: Source: [biz.yahoo.com/glossary/bfglosg.html](http://biz.yahoo.com/glossary/bfglosg.html)
13. Globalization alternative definition: Source [www.agtrade.org/defs.cfm](http://www.agtrade.org/defs.cfm)
14. An early National Nanotechnology Initiative (NNI) document (National Science & Technology Council [NSTC], 2000)

## Appendix - I

### What is a policy?

Policy<sup>11</sup> is defined as “A course of action, guiding principle, or procedure considered expedient, prudent, or advantageous”.

**What is globalization?** – Globalization is the “Tendency toward a worldwide investment environment, and the integration of national capital markets<sup>12</sup>”.

**Or** “The increasing integration of world markets for goods, services, and capital. It has also been defined as a process by which nationality becomes increasingly irrelevant in global production and consumption<sup>13</sup>”.

**Nano Super Weapons** – Any class of assembler weapon capable of molecular self reproduction such that it behaves in a programmable DNA/m-RNA manner but instead of assembling using protein, any substance may serve as the “assembly raw material” For example, hair cells reproduce themselves to grow more hair per their DNA instruction set. The assembly of the new hair is accomplished mainly using protein. In a weapon, the protein would be substituted for by any material thus creating a “cancer” like device but with far greater destructive capability since any thing could be the “protein”. The Feynman vision<sup>14</sup> (and rhetoric echoing it) motivated the U.S. National Nanotechnology Initiative(NNI). An early NNI document (National Science & Technology Council [NSTC], 2000) stated under “Definition of Nanotechnology” that “the essence of nanotechnology is the ability to work at the molecular Level, atom by atom, to create large structures with fundamentally new molecular organization.”