



**Topic N06-059 Final Phase I Report**  
**Report # NEC 0004, Item # 0001AD (Data Item A002)**

Contract Number: N6553806M0156

Report Period: May 4, 2006 – October 30, 2006

Contract Amount: \$ 69,777.64

Topic and Phase: Replaceable Inserts for Ship's Line Handling Chocks

Technical POC: Michael Bergen  
Naval Surface Warfare Center; Carderock  
9500 MacArthur Blvd.  
West Bethesda, MD 20817-5700

Sponsor: Glen Sturtevant PEO SHIP  
Naval Sea System Command  
875 N. Randolph Street  
Arlington, VA 22205-1995

SBIR Title: Ship Chock Insert

Period of Performance: May 4, 2006 – January 4, 2006

Security Classification: None

  
\_\_\_\_\_  
Carolyn S. Seringer, Vice President, POC

October 30, 2006

Expiration of SBIR Data Rights Period: October 30, 2011  
Nelson Engineering Co. exerts its data rights for the data contained in this document and under Contract N00024-05-C-4150. The Government's rights to use, modify, reproduce, release, perform, display, or disclose technical data or computer software marked with this legend are restricted during the period shown as provided in DFARS 252.227-7018 and as described in the SBIR contract for which this work was performed. Any reproduction of technical data, computer software, or portions thereof marked with this legend must also reproduce the markings. (End of legend)

**REPORT DOCUMENTATION PAGE**Form Approved  
OMB No. 0704-0188

Public reporting burden for this collection of information is estimated to average 1 hour per response, including the time for reviewing instructions, searching data sources, gathering and maintaining the data needed, and completing and reviewing the collection of information. Send comments regarding this burden estimate or any other aspect of this collection of information, including suggestions for reducing this burden to Washington Headquarters Service, Directorate for Information Operations and Reports, 1215 Jefferson Davis Highway, Suite 1204, Arlington, VA 22202-4302, and to the Office of Management and Budget, Paperwork Reduction Project (0704-0188) Washington, DC 20503.

**PLEASE DO NOT RETURN YOUR FORM TO THE ABOVE ADDRESS.****1. REPORT DATE (DD-MM-YYYY)**

30-10-2006

**2. REPORT TYPE**

Final

**3. DATES COVERED (From - To)**

May 4, 2006 – October 30, 2006

**4. TITLE AND SUBTITLE**Topic N06-059 Final Phase I Report  
Replaceable Inserts for Ship's Line Handling Chocks**5a. CONTRACT NUMBER**

N6553806M0156

**5b. GRANT NUMBER****5c. PROGRAM ELEMENT NUMBER****6. AUTHOR(S)**Dehler, Jason W.  
Hayman, Michael J.  
Seringer, Carolyn S.**5d. PROJECT NUMBER****5e. TASK NUMBER****5f. WORK UNIT NUMBER****7. PERFORMING ORGANIZATION NAME(S) AND ADDRESS(ES)**Nelson Engineering Co.  
3655 Belle Arbor Cr.  
Titusville, FL 32780**8. PERFORMING ORGANIZATION  
REPORT NUMBER**

NEC 0004

**9. SPONSORING/MONITORING AGENCY NAME(S) AND ADDRESS(ES)**Glen Sturtevant PEO SHIP  
Naval Sea System Command  
875 N. Randolph Street  
Arlington, VA 22205-1995**10. SPONSOR/MONITOR'S ACRONYM(S)**

PEO Ship

**11. SPONSORING/MONITORING  
AGENCY REPORT NUMBER****12. DISTRIBUTION AVAILABILITY STATEMENT**

Unclassified, Approved for Public Release

**13. SUPPLEMENTARY NOTES****14. ABSTRACT**

The Navy seeks an innovative solution to decrease the high expense associated with replacing ship mooring lines due to the excessive wear that occurs when chaffed across rough operating surfaces such as shipboard mooring chocks. Nelson Engineering Company was awarded a Phase I Small Business Innovation Research (SBIR) contract to investigate the capabilities of Nylatron® NSM, a new self-lubricating polymer with high surface smoothness and wear resiliency, and its potential for use in a chock insert designed to significantly reduce wear on mooring lines.

Physical and chemical material tests were conducted on Nylatron® NSM, including exposing samples to abrasive and loading conditions designed to simulate chock insert operating conditions and subjecting samples to a simulated outdoor corrosive marine environment. Results show that Nylatron® NSM:

- Does not chemically alter or break down when exposed to a simulated marine environment or prolonged UV exposure.
- Is chemically inert.
- Maintains an exceptionally smooth surface and creates minimal particulate material when abraded.
- Performs elastically under operational conditions and plastically deforms under mooring line safety factor loading conditions without cracking.

A Nylatron® NSM full scale two-piece insert prototype was developed to demonstrate constructability and facilitate attachment method concept visualization. The initial cost analysis indicates significant program savings (approximately \$3,000,000 per year for the Destroyer fleet).

**INSTRUCTIONS FOR COMPLETING SF 298**

**15. SUBJECT TERMS**

chock insert; chock; mooring lines; Nylatron®; advanced polymer

**16. SECURITY CLASSIFICATION OF:**

a. REPORT  
U

b. ABSTRACT  
U

c. THIS PAGE  
U

**17. LIMITATION OF ABSTRACT**  
SAR

**18. NUMBER OF PAGES**  
62

**19a. NAME OF RESPONSIBLE PERSON**  
Carolyn S. Seringer

**19b. TELEPHONE NUMBER (include area code)**  
321-403-0454

## TABLE OF CONTENTS

SECTION.....	Page
<b>1.0 Executive Summary.....</b>	<b>1</b>
<b>2.0 Introduction.....</b>	<b>2</b>
<b>3.0 Technical Objectives .....</b>	<b>4</b>
<b>4.0 System Requirements .....</b>	<b>5</b>
<b>5.0 Chemical Testing Results .....</b>	<b>8</b>
5.1 Salt Water Environment Degradation .....	8
5.1.1 Salt Water Simulation.....	8
5.1.2 Analysis Methods .....	8
5.1.3 Results.....	10
5.1.4 Electrochemical Simulation .....	13
5.1.5 Results.....	14
5.2 Ultraviolet (UV) Exposure.....	16
5.2.1 UV Test.....	16
5.2.2 FTIR UV Exposure Results .....	17
5.3 Chemical Reactivity .....	18
<b>6.0 Environmental.....</b>	<b>19</b>
<b>7.0 Physical.....</b>	<b>20</b>
7.1 Surface Roughness and Preferential Wearing .....	20
7.1.1 Wear Testing.....	20
7.1.2 Results.....	22
7.2 Strength.....	23
7.2.1 Cyclical Load Testing .....	29
7.2.2 Failure Testing .....	33
7.3 Color .....	38
<b>8.0 Functional .....</b>	<b>39</b>
8.1 Inner Diameter .....	39
8.2 Cost .....	39
8.3 Attachment Method.....	41
8.3.1 Pin Insert Method.....	43
8.3.2 Band Clamp Method .....	44
8.3.3 Snap Method.....	45
8.3.4 Final Attachment Method .....	45
<b>9.0 Prototype.....</b>	<b>46</b>
<b>10.0 Conclusions and Recommendations .....</b>	<b>47</b>
<b>11.0 Phase II Potential .....</b>	<b>48</b>
<b>12.0 Phase III Transition Plan .....</b>	<b>50</b>

The data on this page are protected according to the data rights language provided on the title page of this document and can not be modified, reproduced, released or disclosed unless in accordance with terms on the cover page.

## APPENDICES

Appendix A: Nylatron® NSM MSDS

Appendix B: Chock Insert Prototype Design Drawings

## FIGURES

<b>Figure 2-1: Chock Surface and Mooring Line Damage Examples .....</b>	<b>2</b>
<b>Figure 2-2: Nylatron® NSM Sample .....</b>	<b>3</b>
<b>Figure 5-1: FTIR Spectrometer .....</b>	<b>9</b>
<b>Figure 5-2: Electron Microprobe Analyzer .....</b>	<b>10</b>
<b>Figure 5-3: FTIR Results .....</b>	<b>12</b>
<b>Figure 5-4: EMPA Results (Identical For Every Sample) .....</b>	<b>13</b>
<b>Figure 5-5: Electrochemical Test Setup .....</b>	<b>14</b>
<b>Figure 5-6: Nylatron® NSM Sample Electrochemical Impedance Spectra, Voltage Range 0 to 10Volts .....</b>	<b>15</b>
<b>Figure 5-7: Stainless Steel Sample Electrochemical Impedance Spectra, Voltage Range 0 to 10V15</b>	
<b>Figure 5-8: Nylatron® NSM UV Exposure.....</b>	<b>16</b>
<b>Figure 5-9: UV Radiation Exposed Sample EMPA Results .....</b>	<b>17</b>
<b>Figure 5-10: UV Radiation Exposed Sample FTIR Spectroscopy Results .....</b>	<b>18</b>
<b>Figure 7-1: Pin on Disk Tribometer Illustration .....</b>	<b>21</b>
<b>Figure 7-2: Pin on Disk Set Up, Front View .....</b>	<b>21</b>
<b>Figure 7-3: Pin on Disk Set Up, Side Views .....</b>	<b>22</b>
<b>Figure 7-4: Mooring Line Contact Area .....</b>	<b>24</b>
<b>Figure 7-5: Mooring Line Tension Induced Chock Insert Normal Stress.....</b>	<b>25</b>
<b>Figure 7-6: FEA Stress Distribution at 100,000 Pounds of Mooring Line Tension .....</b>	<b>26</b>
<b>Figure 7-7: Mooring Line Flattening Around Chock.....</b>	<b>27</b>
<b>Figure 7-8: FEA Stress Distribution at 300,000 lbs of Mooring Line Tension .....</b>	<b>28</b>
<b>Figure 7-9: Nylatron® MC907 Stress Strain Curve.....</b>	<b>29</b>
<b>Figure 7-10: Load versus Time.....</b>	<b>30</b>
<b>Figure 7-11 Displacement versus Time .....</b>	<b>31</b>
<b>Figure 7-12: Scanning Electron Microscope View of Cyclical Loading .....</b>	<b>32</b>
<b>.Figure 7-13: Scanning Electron Microscope View of Virgin Nylatron® NSM .....</b>	<b>32</b>
<b>Figure 7-14: Distributed Load to Failure Stress versus Time .....</b>	<b>33</b>
<b>Figure 7-15: Scanning Electron Microscope View of Distributed Load Plastic Deformation .....</b>	<b>34</b>
<b>Figure 7-16: Test Section Surface after Distributed Load to Failure Testing .....</b>	<b>34</b>

The data on this page are protected according to the data rights language provided on the title page of this document and can not be modified, reproduced, released or disclosed unless in accordance with terms on the cover page.

<b>Figure 7-17 Cylindrical Load Setup.....</b>	<b>35</b>
<b>Figure 7-18: Cylindrical Load to Failure Stress versus Time.....</b>	<b>36</b>
<b>Figure 7-19: Test Section Surface after Cylindrical Load to Failure Testing .....</b>	<b>37</b>
<b>Figure 7-20: Scanning Electron Microscope View of Distributed Load Plastic Deformation .....</b>	<b>37</b>
<b>5000x Magnification.....</b>	<b>37</b>
<b>Figure 8-1: Initial Two Piece Chock Insert Design .....</b>	<b>42</b>
<b>Figure 8-2: Various Chock Configurations .....</b>	<b>42</b>
<b>Figure 8-3: Pin Insert Attachment Method (One Piece) .....</b>	<b>43</b>
<b>Figure 8-4: Pin Insert Attachment Method (Exploded View) .....</b>	<b>44</b>
<b>Figure 8-5: Band Clamp Attachment Method.....</b>	<b>44</b>
<b>Figure 8-6 Snap Attachment Method .....</b>	<b>45</b>
<b>Figure 10-1: Other Potential Wear Surfaces .....</b>	<b>49</b>

**TABLES**

<b>Table 1: Chemical Requirements- Material .....</b>	<b>5</b>
<b>Table 2: Environmental Requirements - Material .....</b>	<b>6</b>
<b>Table 3: Physical Requirements - Material.....</b>	<b>6</b>
<b>Table 4: Functional Requirements – Chock Insert .....</b>	<b>7</b>
<b>Table 5: Weight Gain After Salt Water Exposure.....</b>	<b>11</b>
<b>Table 6: UV Exposure Results.....</b>	<b>16</b>
<b>Table 7: Wear Testing Results.....</b>	<b>23</b>
<b>Table 8: Cyclical Load Test Results.....</b>	<b>31</b>
<b>Table 9: Nylatron® NSM Chock Insert Fabrication Costs .....</b>	<b>40</b>
<b>Table 10: Annual Nylatron® NSM Chock Insert Program Component Cost Estimation (RIM Fabrication Method and 5 Year Useful Life Expectancy).....</b>	<b>41</b>

## 1.0 Executive Summary

The U.S. Navy is currently seeking an innovative solution to decrease the high expense associated with replacing ship mooring lines. This expense is primarily due to the excessive wear that lines encounter when chaffed across rough operating surfaces (usually shipboard mooring chocks). Nelson Engineering Company was awarded a Phase I Small Business Innovation Research (SBIR) contract to investigate the capabilities of a new age self-lubricating polymer known as Nylatron® NSM and its potential for use in a chock insert designed to significantly reduce the wear imparted to the mooring lines. Nylatron® NSM has supreme surface smoothness and wear resiliency which is paramount to a chock insert application.

A requirement list was established to determine Nylatron® NSM's suitability for this application. The list stemmed from the Navy's initial solicitation as well as Nelson Engineering Co.'s understanding of the problem coupled with Navy Technical Point of Contact (TPOC) feedback. Physical and chemical material tests were conducted, including exposing samples to abrasive and loading conditions designed to simulate chock insert operating conditions and subjecting samples to a simulated outdoor corrosive marine environment.

Phase I test results indicate that Nylatron® NSM outperformed expectations in every area. Nylatron® NSM:

- Does not chemically alter or break down when exposed to a simulated marine environment or prolonged UV exposure.
- Is chemically inert and will not negatively impact the environment.
- Maintains an exceptionally smooth surface and creates minimal particulate material when abraded.
- Performs elastically under operational conditions and plastically deforms under mooring line safety factor loading conditions without cracking.

Nelson Engineering Co. is developing a Nylatron® NSM full scale two-piece insert prototype during Phase I to demonstrate constructability and facilitate attachment method concept visualization. The positive Phase I material study results combined with Nelson Engineering Co.'s innovative implementation approach warrant further study. A Phase II SBIR award would provide the opportunity to thoroughly investigate the actual mooring line wear reduction amount provided by the Nylatron® NSM contact surface. Also, insert concept configuration optimization is needed. Full scale testing is needed to determine if the proposed attachment method is best. The initial cost analysis indicates significant program savings (approximately \$3,000,000 per year for the Destroyer fleet), but an intensive study over a longer time would allow insert life to be determined which would allow a more accurate chock insert program cost savings to be determined.

## 2.0 Introduction

The method used to secure massive Navy ships docked at port is an engineering feat that has remained virtually unchanged over the last century. Although mooring lines replacements have taken advantage of material advancements, little or no technological advances have been applied to the surfaces the lines regularly contact. The structural members, known as chocks, that guide the lines are constructed of high strength steel and painted with the same coating that is used to cover the ship's exterior surfaces.

Technological material advances have made the mooring lines lighter, stronger and more durable. These lines are currently constructed of high strength polymers and are load tested to 300,000 pounds. According to the Navy mooring line supplier (White Hill Manufacturing Co.), the cost of a single new mooring line currently ranges from \$3400 to \$4300. A typical destroyer has 20 to 50 lines onboard. Extending the life of mooring lines would produce significant cost savings.

Navy ships are very well maintained, however metallic surface corrosion, chipped paint, and other damage is unavoidable in an active marine environment. The need to replace mooring lines is caused primarily by line damage resulting from lines rubbing across the metal chock surface. Chock surface defects cause the mooring lines to chafe across a rough surface while the lines are being rigged to secure the ship. Further damage to the lines, rigging equipment and chocks is caused by the rubbing associated with tidal changes while the ship is tied down at port. This excessive friction and abrasion causes localized line surface fiber heating which weakens and eventually structurally compromises the lines. Examples of damaged chocks and mooring lines are shown in Figure 2-1.

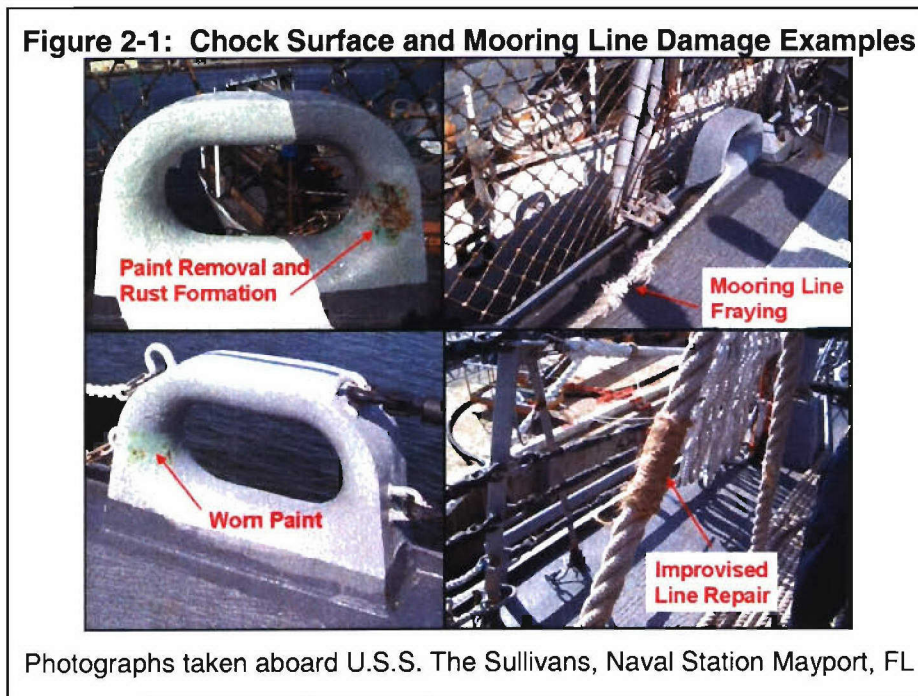

The data on this page are protected according to the data rights language provided on the title page of this document and can not be modified, reproduced, released or disclosed unless in accordance with terms on the cover page.

To eliminate mooring line damage and decrease the resulting line replacement rate, significant improvement in mooring line contact surface quality must be achieved. Contact surface improvement can be accomplished through the research and development of a commercially-viable, easily installed and replaceable chock insert. Such an insert must maintain a smooth surface while being subjected to the mooring line rubbing conditions and exposed to a harsh marine environment. The insert must also be strong enough to withstand largest forces transferred into the chock from the mooring line. The insert must not be flammable or toxic or have a large radar cross-section. The insert color cannot be contrasting, which could draw attention to the ship. Shipboard personnel must be able to easily install, remove and replace the insert with no alterations made to the chock itself. Simplicity, functionality, and reliability are the keys to success for any shipboard solution.

Nelson Engineering Co.'s approach was to develop a simple, inexpensive, two-piece, self-lubricating, chock insert fabricated from a new-age plastic material known as Nylatron® NSM, shown in Figure 2-2. The goals of Phase I Small Business Innovation Research (SBIR) project were to perform material tests that determine Nylatron® NSM's suitability for this application and to fabricate an actual insert prototype to confirm constructability. This final report provides analysis of Nylatron® NSM performance when subjected to similar wearing, loading, and environmental conditions to those that a chock insert will encounter when installed aboard a ship.

Mooring line wear affects all ships, both military and civilian. This chock insert design is dimensioned and rated for a DDG class ship because the Navy has earmarked this class as the first platform for installation. All technology discussed in this report can be redesigned to fit any chock in all US Navy ships as well as all civilian vessels.

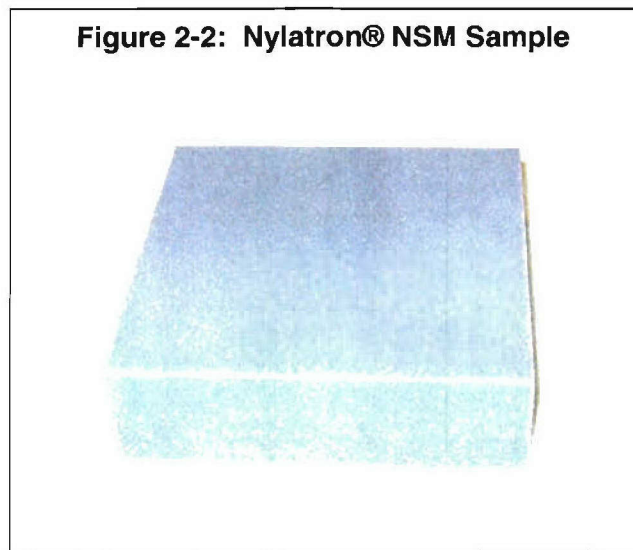

### 3.0 Technical Objectives

The following technical objectives were accomplished during Phase I:

1. Fully demonstrate that Nylatron® NSM material will:
  - Not physically or chemically breakdown in a simulated marine environment (Section 5)
  - Maintain the required surface smoothness when subjected to simulated wearing (Section 7.1)
  - Be mechanically strong enough to withstand the required loading (Section 7.2).
2. Design, fabricate, and deliver one (1) Nylatron® NSM chock insert prototype (Section 9) to the U.S. Navy to demonstrate construction feasibility.

#### 4.0 System Requirements

A System Requirement Matrix (SRM) was developed to document the chock insert requirements for use onboard class DDG Navy ships. Requirements were broken down into five categories: chemical, environmental, physical, and functional. A validation method was determined for each requirement and completed during Phase I.

Chemical requirements, contained in Table 1, were driven by conditions the chock insert will be exposed to when installed onboard a ship. The insert must undergo limited break-down from ultraviolet light and saltwater exposure. It must not react chemically when placed in contact with other chemicals used in ship operations. These requirements were validated by exposing test sections to ultraviolet light for an extended period of time as well and exposing test sections to a simulated corrosive environment. The samples were then tested using chemical and physical analysis tools to determine the extent of weathering, chemical reactions, or loss of integrity.

<b>Table 1: Chemical Requirements- Material</b>		
R1-1	Salt Water Degradation	No physical breakdown or chemical alteration from prolonged exposure to salt water or marine atmosphere.
Validation Method		Perform the following high fidelity material analyses: on Nylatron® NSM test samples prior to and following marine environment simulation. <ol style="list-style-type: none"> <li>1. Fourier Transform Infrared (FTIR) Spectroscopy</li> <li>2. Electron Microprobe Analysis (EMPA)</li> </ol>
R1-2	UV Breakdown	No physical alteration due to prolonged exposure to sun light.
Validation Method		Secure material test sample outside near the Atlantic Ocean for duration of Phase I period of performance. Evaluate visually and physically (weight, size, volume) and document measurements of any induced swelling or warping or loss of material. Perform the following high fidelity material analyses: on Nylatron® NSM test samples prior to and following UV exposure. <ol style="list-style-type: none"> <li>1. Fourier Transform Infrared (FTIR) Spectroscopy</li> <li>2. Electron Microprobe Analysis (EMPA)</li> </ol>
R1-3	Chemically Inert	No chemical reactions with other typical materials (spills or fumes) used in ship operations.
Validation Method		Material Safety Data Sheet (MSDS)

Table 2 contains the requirement related to the material's impact on the surrounding environment. Chemical properties of Nylatron® NSM will determine where the insert would be stored and what impact the insert may have on the storage area. The environmental requirement was validated using information contained in the Material Safety Data Sheet (MSDS).

<b>Table 2: Environmental Requirements - Material</b>		
R2-1	Environmental Impact	Requires no specialized storage or handling methods.
Validation Method		Material Safety Data Sheet

Physical requirements contained in Table 3 address how the insert will mechanically perform while in use. The insert must maintain a smooth surface, withstand the force of the mooring line while at full tension, and not preferentially wear into large particulate matter that cause line fouling. The physical requirements were validated by subjecting test sections to abrasion testing. The surface roughness and size of particulate matter resulting from wear were measured. In addition, test sections were examined using a Scanning Electron Microscope (SEM) to look for surface cracks after the material had been loaded to simulate field conditions.

<b>Table 3: Physical Requirements - Material</b>		
R3-1	Surface Roughness	Maintain a surface roughness factor of 125 micro inches or less.
Validation Method		Pin-on-disk abrasion testing combined with a surface roughness measuring device. In addition, a scanning electron microscope (SEM) was employed to analyze wear patterns. A surface roughness factor of greater than 125 micro inches is unacceptable.
R3-2	Preferential Wearing	Must not shed material particles that will cause block, sheave and capstan fouling while rigging, fouling or gearing issues with deck equipment, or cause other maintenance issues. Exfoliated particles must be no larger than 5.0 micro inches; material must not shed more than one (1) ounce of material in a three (3) hour continuous wear simulation period.
Validation Method		Measure particle size distribution of particles shed during abrasion testing. Weigh sample before and after abrasion testing to determine total material loss.
R3-3	Strength	Withstand compressive force resulting from simulated loading within the mooring line tension operational envelope (0 to 100,000 pounds). Material must not crack or break into pieces that could foul the mooring line and/or present an unsafe situation as tensions in the safety factor realm are encountered (100,000 to 300,000 pounds).
Validation Method		Cyclically load the material to simulate tidal conditions. The material must behave elastically. An average material displacement of more than 10 percent (0.10 inches) is unacceptable. Material must deform plastically when loaded to point of failure.
R3-4	Color	The material should blend with the ship deck color scheme.
Validation Method		Navy approval of color

The data on this page are protected according to the data rights language provided on the title page of this document and can not be modified, reproduced, released or disclosed unless in accordance with terms on the cover page.

Table 4 contains the functional requirements which address insert design. The insert must not impede a mooring line from moving smoothly through a chock, must not add to the radar cross section of the ship and should be relatively inexpensive. The chock insert must be securely installed, remain static during line rigging operations, accommodate every possible chock configuration, and not contain any sharp edges or seams that could potentially abrade the mooring line.

<b>Table 4: Functional Requirements – Chock Insert</b>		
R4-1	Inner Diameter	Insert must allow all line sections to freely pass through. Largest possible line section diameter is 2.33 inches. Two (2) lines must be able to pass through at once. The inner chock diameter is equal to seven (7) inches. This yields an approximate excess space of 2.33 inches. Assuming a uniform chock insert thickness, the maximum allowable insert thickness is approximately 1.16 inches.
Validation Method		Design drawings and abrasion testing
R4-2	Cross Section	Chock insert does not change cross sectional ship platform
Validation Method		Design drawings
R4-3	Low Cost	Production cost per unit shows cost savings when compared to current mooring line replacement expense.
Validation Method		Design drawings, final cost estimate
R4-4	Attachment	The attachment method must not compromise the satisfaction of other performance requirements (fouling of lines, insert structural integrity). No alterations can be made to the actual chock it (e.g. no screwed connections to chock).
Validation Method		Design drawings

## 5.0 Chemical Testing Results

A US Navy vessel deck is a very harsh environment presenting both natural and manmade challenges to any material installed onboard. Two main challenges are the corrosive effects of sea water and extended ultraviolet (UV) ray exposure. In addition, because a US Navy ship is inherently an industrial environment, a chock insert will be exposed to a variety of chemicals such as weapon firing exhaust and paint fumes. To be suitable for this application, the chock insert material must not physically break down or chemically change when exposed to these conditions.

### 5.1 Salt Water Environment Degradation

Since this insert is being installed on the ship deck, it will be exposed to salt water and sea spray. Three types of salt water degradation were considered. The first two account for the corrosive nature of salt water. A chock insert must not corrode, react or chemically break down upon prolonged exposure to salt water. Corrosion or reaction products will affect the surface roughness and increase wear on the mooring line. Chemical material break down degrades the insert strength and durability.

The third salt water degradation issue deals with electrical conductivity. Rapid corrosion takes place when two conductive materials, such as stainless steel, carbon steel or copper, are adjacent or connected by a conductor. An active marine environment increases the likelihood that salt water would intrude between the chock and the insert. A conductive insert will accelerate chock corrosion. Although polymers such as Nylatron® NSM are known not to be conductive materials, testing was done to determine if any of the proprietary additives in Nylatron® NSM were conductive and could contribute to accelerated chock corrosion in the ship's salt water environment.

#### 5.1.1 Salt Water Simulation

Nylatron® NSM samples were cut into the desired dimensions (20 millimeters (mm) by 20 mm by 2 mm thick) for simulated sea water condition corrosion tests. The samples were kept in 3.5% sodium chloride (NaCl) solution for 21 days. The initial and final sample weights were measured. The samples were kept in a vacuum at room temperature for three (3) days to remove the adsorbed water on the surface and weights were remeasured.

These samples were analyzed to determine if they had broken down or chemically changed. Two chemical analysis methods were used to make this determination. Fourier Transform Infrared (FTIR) spectroscopy was used to analyze the carbon bonds in the polymer and check for chemical structural stability. An Electron Microprobe Analysis (EMPA) determined the test sample chemical composition.

#### 5.1.2 Analysis Methods

##### 5.1.2.1 FTIR Spectroscopy

FTIR spectroscopy is used primarily for determining the chemical structure of organic compounds. Because chemical bonds absorb infrared energy at specific frequencies, the basic

The data on this page are protected according to the data rights language provided on the title page of this document and can not be modified, reproduced, released or disclosed unless in accordance with terms on the cover page.

structure of compounds can be determined by the spectral locations of their infrared (IR) absorptions. The plot of a compound's IR transmission versus wavenumber is its "fingerprint", which when compared to reference spectra, identifies the material. The wavenumber is commonly used in spectroscopy and refers to the inverse wavelength of the chemical bond energy level. FTIR spectroscopy was used to determine the integrity of the carbon-carbon, carbon-oxygen and carbon-nitrogen bonds in the Nylatron® NSM before and after sea water exposure.

Nylatron® NSM samples were analyzed by the University of Central Florida (UCF) Advanced Materials Processing and Analysis Center (AMPAC) using a Perkin-Elmer FTIR spectrometer (Serial Number: 1500F1967), shown in Figure 5-1, to determine the integrity of the carbon-carbon, carbon-oxygen and carbon-nitrogen bonds. Attenuated Total Reflectance (ATR) mode was used as it is highly sensitive to the polymer surface. Samples were scanned in the amplitude range of 600 to 4000 inverse centimeter ( $\text{cm}^{-1}$ ) to analyze chemical bond modifications after exposing samples to simulated sea water conditions described in Section 5.1.1.

**Figure 5-1: FTIR Spectrometer**

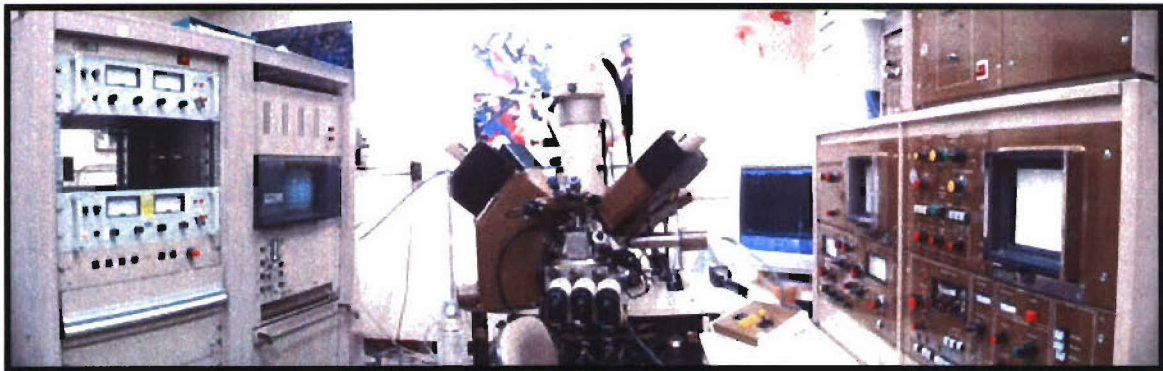

#### **5.1.2.2 Electron Microprobe Analysis (EMPA)**

EMPA is a non-destructive method for determining the chemical composition of tiny amounts of solid materials. EMPA uses a high-energy, focused beam of electrons to detect and measure the characteristic X-rays of elements within a sample material. Analysis locations are selected using a transmitted-light optical microscope. A chemical composition examination of the test sections layer by layer determines if the material surface is chemically changing as a result of corrosive environment exposure and exactly how deep changes are occurring within the material. EMPA analysis was conducted by UCF's AMPAC, using the analyzer (JEOL Superprobe 733) shown in Figure 5-2.

**Figure 5-2: Electron Microprobe Analyzer**

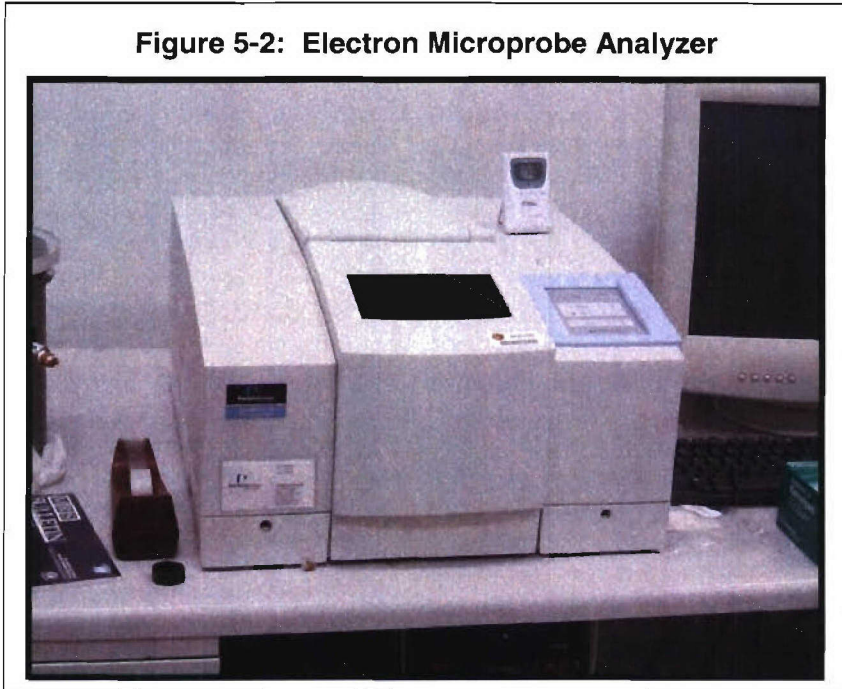

### 5.1.3 Results

#### 5.1.3.1 Salt Water Simulation Weight Change

After exposing samples to simulated sea water conditions described in Section 5.1.1 and after vacuum drying, the Nylatron® NSM samples were weighed. The sample weight results are shown in Table 5. The average weight gain of the 20 samples after 21 days is 20.54 milligrams.

The samples were kept under vacuum at room temperature for three days to remove the adsorbed water molecules to try to eliminate water as a reason for weight gain. After vacuum drying, the average sample weight gain was 10.35 milligrams, which is less than two percent (2%) of the sample weight. Reasons for weight gain include:

- Water was not completely removed.
- Sodium chloride adheres to the polymer.
- Polymer reaction products were formed.

Additional research into the cause of weight gain will be part of the Phase II investigation (see Section 11). However, sodium chloride adherence and formation of polymer reaction products are unlikely, given the before and after spectroscopy (Section 5.1.3.2) and EMPA (Section 5.1.3.3).

**Table 5: Weight Gain After Salt Water Exposure**

Sample #	Initial Weight (mg)	Weight After Salt Water Simulation (mg)	Weight After Vacuum Drying (mg)	Weight Gain After Vacuum Drying (mg)
1	551	571	561	10
2	528	550	539	11
3	545	566	556	11
4	538	558	548	10
5	602	623	612	10
6	515	535	525	10
7	549	568	558	9
8	533	552	542	9
9	478	497	488	10
10	575	597	586	11
11	529	553	541	13
12	496	516	506	10
13	506	524	516	10
14	518	538	528	10
15	562	585	574	12
16	548	569	559	11
17	537	556	547	10
18	512	532	521	9
19	622	644	633	11
20	522	543	532	10

### 5.1.3.2 FTIR Spectroscopy Results

The FTIR characterization was performed on a virgin Nylatron® NSM sample in addition to ten (10) test samples exposed to the sea water simulation, as described in Section 5.1.1.

The carbon-carbon, carbon-oxygen, and carbon-nitrogen bond integrities were determined by comparing a virgin Nylatron® NSM sample with samples that had been subjected to sea water exposure simulation. Transmittance intensities at known bond wavelengths were measured and are shown in Figure 5-3. No peak intensity variation or peak position shift was observed in the samples subjected to sea water. This indicates no breakdown in polymer structure and no surface chemical changes.

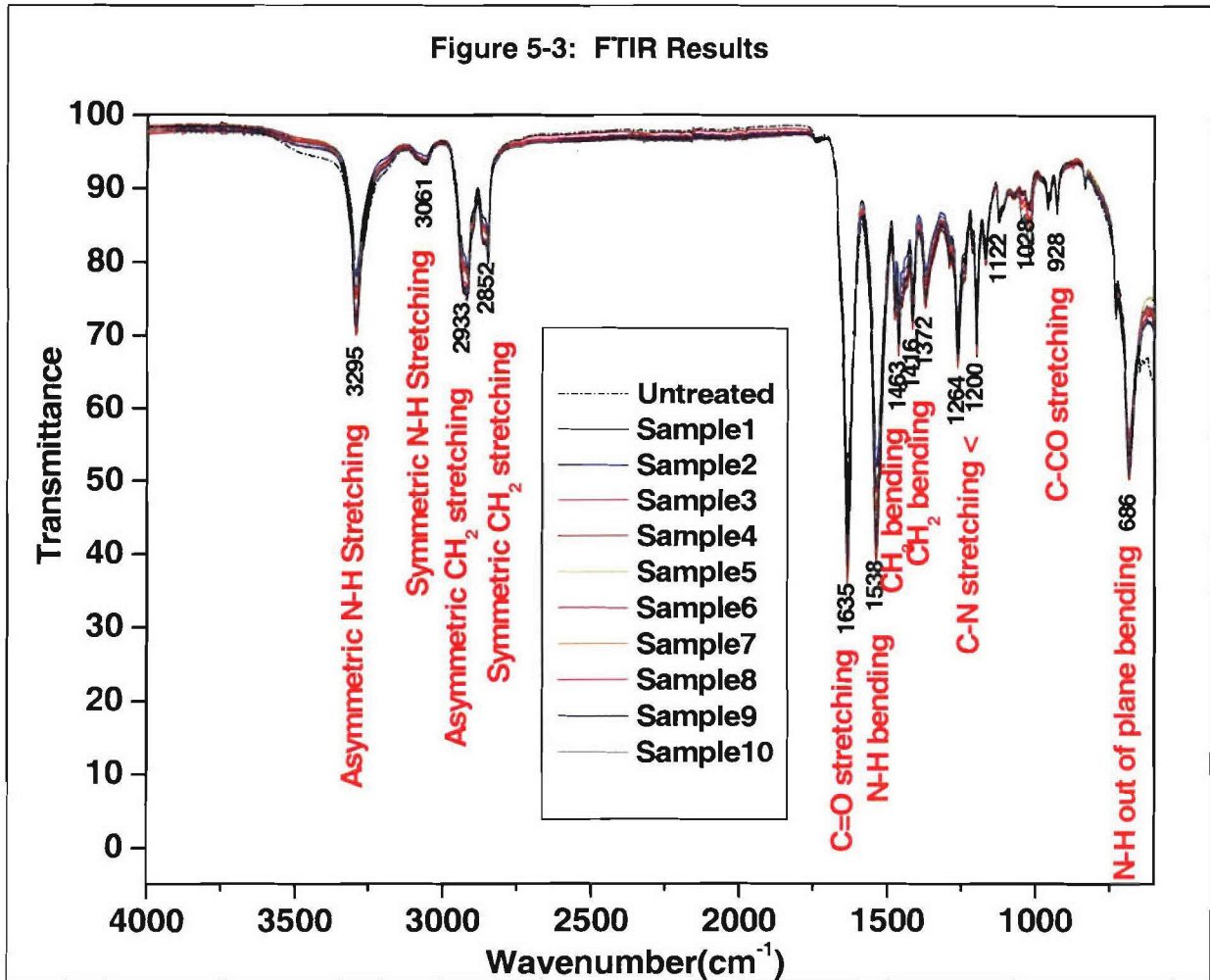

### 5.1.3.3 Electron Microprobe Analysis (EMPA) Results

EMPA was performed on a virgin Nylatron® NSM sample in addition to ten (10) test samples exposed to the sea water simulation, as described in Section 5.1.1. The chemical compositions of an untreated Nylatron® NSM sample and the sea water corrosion tested samples were determined using EMPA analysis. The graph is plotted with emitted X-ray energy (keV) on the X-axis and counts on the Y-axis. The X-ray emitted energy is characteristic of the elements present in the sample and the counts are a measure of intensity of that particular element. Nylatron® NSM is composed mostly of carbon (C), nitrogen (N), and oxygen (O). Results indicate that no chemical composition change occurred. The EMPA produced identical results for all 10 test sections as well as the virgin sample. Figure 5-4 contains the EMPA results.

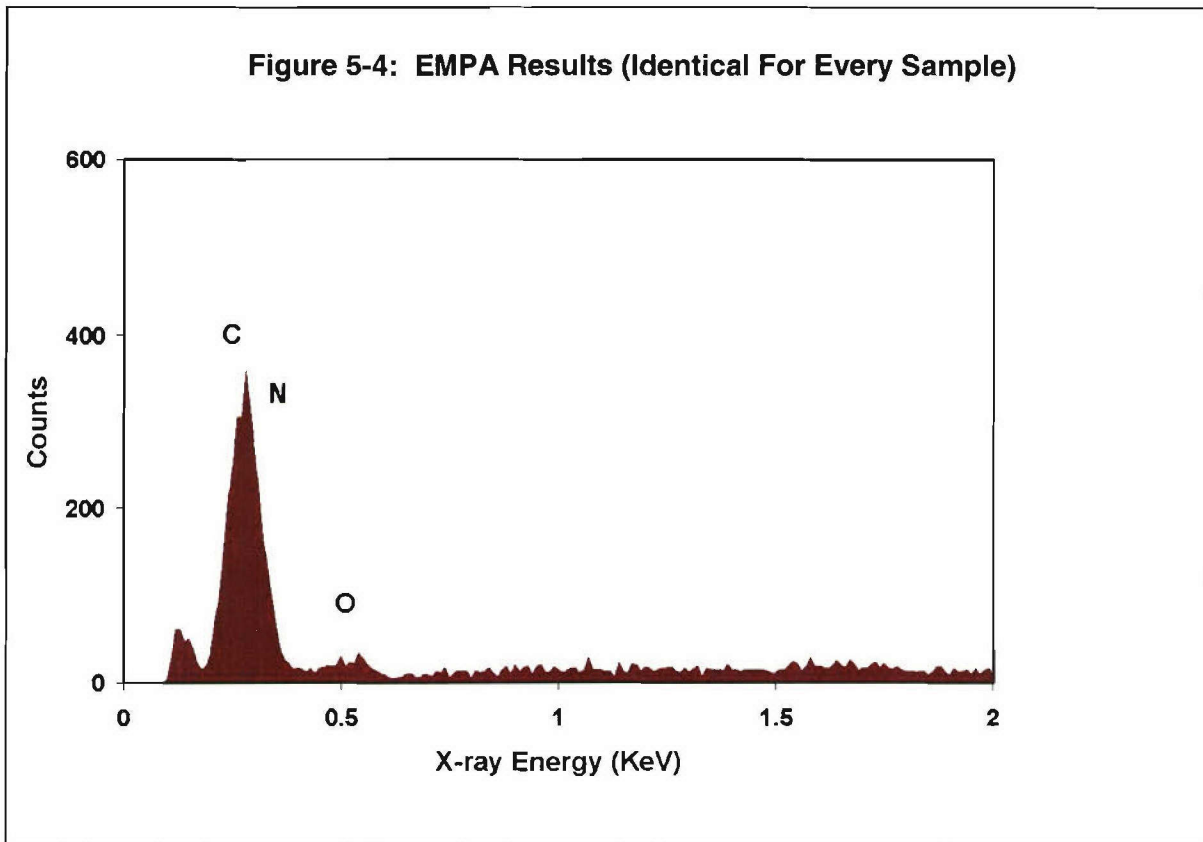

#### 5.1.4 Electrochemical Simulation

##### 5.1.4.1 Analysis Method

Electrochemistry was used to simulate the effects of salt water conductivity on one (1) Nylatron® NSM sample exposed to the sea water simulation described in Section 5.1.1. The electrochemistry test equipment consists of a Potentiostat with a lock-in amplifier. The electrochemical test schematic is shown in Figure 5-5.

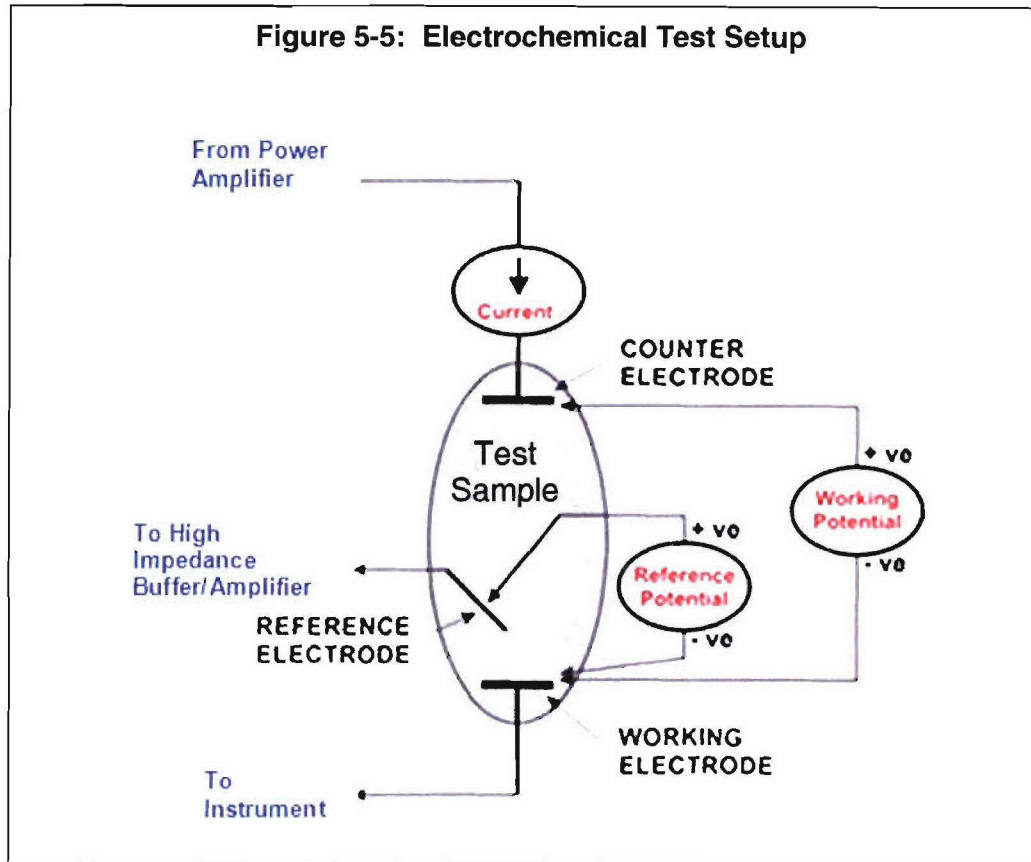

Three electrodes from the amplifier are attached to a Nylatron® NSM test section. These electrodes supply electrical current similar to the electrochemical reaction that occurs when material is subjected to a sea water environment. Varying the charges supplied by the amplifier permits various sea water compositions to be simulated.

Electrochemical tests were conducted by UCF's AMPAC using a Princeton Applied Research Potentiostat. The three electrodes were: reference electrode (silver/silver-chloride), counter electrode (platinum) and working electrode (Nylatron® NSM sample). One cubic centimeter of the sample was exposed to sea water (as electrolyte) while the reference electrode was immersed in saturated potassium chloride (KCl) solution. The current between the working electrode and the counter electrode was measured after applying a potential (0 to 10 volts) across the working and reference electrodes.

### 5.1.5 Results

Polymers such as Nylatron® NSM are known not to be conductive, however proprietary additives in Nylatron® NSM could be conductive and could contribute to accelerated chock corrosion in the ship's salt water environment. The electrochemical test was performed to determine the Nylatron® NSM's ability to conduct electricity, and thus its ability to induce chock corrosion, in a sea water environment. The results, shown in Figure 5-6, indicate no change in the current density (milliamps per square centimeter) in the applied voltage range (0 to 10 volts).

The data on this page are protected according to the data rights language provided on the title page of this document and can not be modified, reproduced, released or disclosed unless in accordance with terms on the cover page.

The plot indicates that the Nylatron® NSM is a poor conductor and should not contribute to accelerated chock corrosion. A conductive material would show an increase in current density as the potential is increased, as shown in Figure 5-7.

**Figure 5-6: Nylatron® NSM Sample Electrochemical Impedance Spectra, Voltage Range 0 to 10Volts**

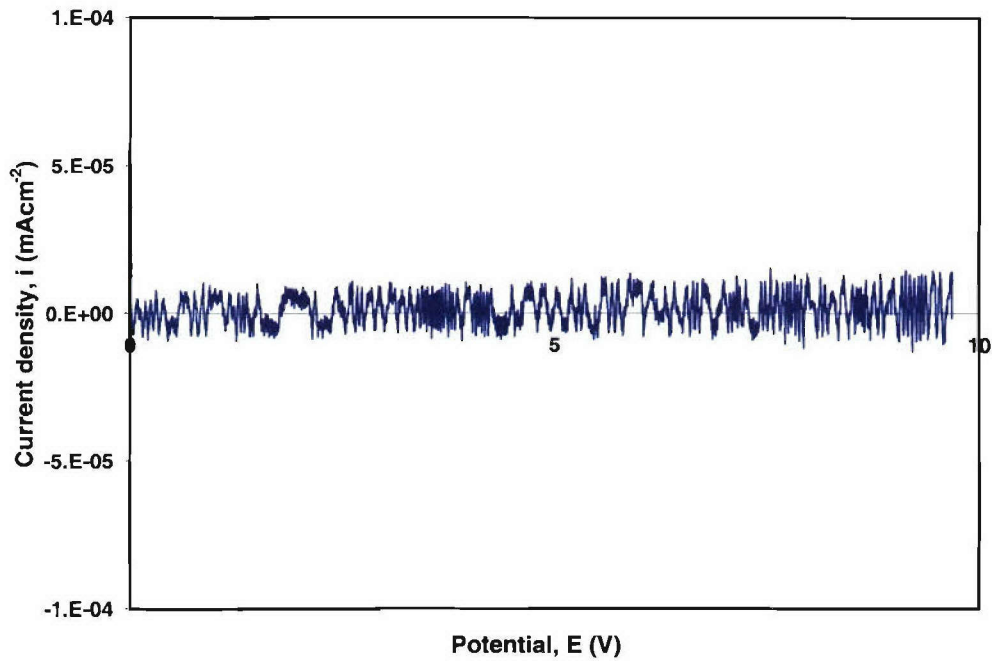

**Figure 5-7: Stainless Steel Sample Electrochemical Impedance Spectra, Voltage Range 0 to 10V**

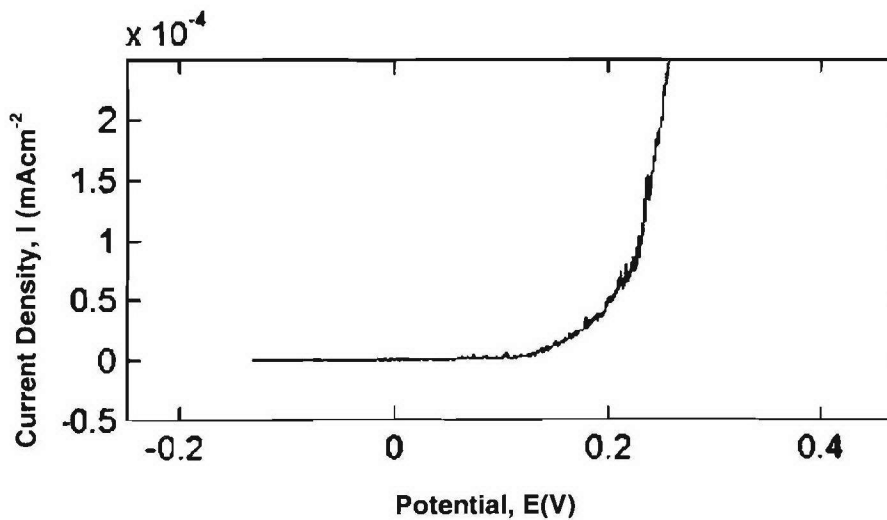

The data on this page are protected according to the data rights language provided on the title page of this document and can not be modified, reproduced, released or disclosed unless in accordance with terms on the cover page.

## 5.2 Ultraviolet (UV) Exposure

### 5.2.1 UV Test

Two (2) Nylatron® NSM samples were securely placed in direct sunlight to evaluate the material's ability to withstand UV radiation (see Figure 5-8). The samples were placed in a shadeless location less than 100 yards from the Atlantic Ocean at Cape Canaveral Air Force Station, Florida on July 15, 2006. One (1) sample was removed on September 15, 2006 (allowing 62 full exposure days) and transported to the UCF Material Testing Laboratory to analyze any UV radiation effects. The sample was measured and weighed and examined using FTIR. Table 6 data show no physical difference after 62 days of exposure. The other sample was left in place to receive additional UV exposure days. This will provide the ability to investigate extended exposure effects as part of a Phase II investigation.

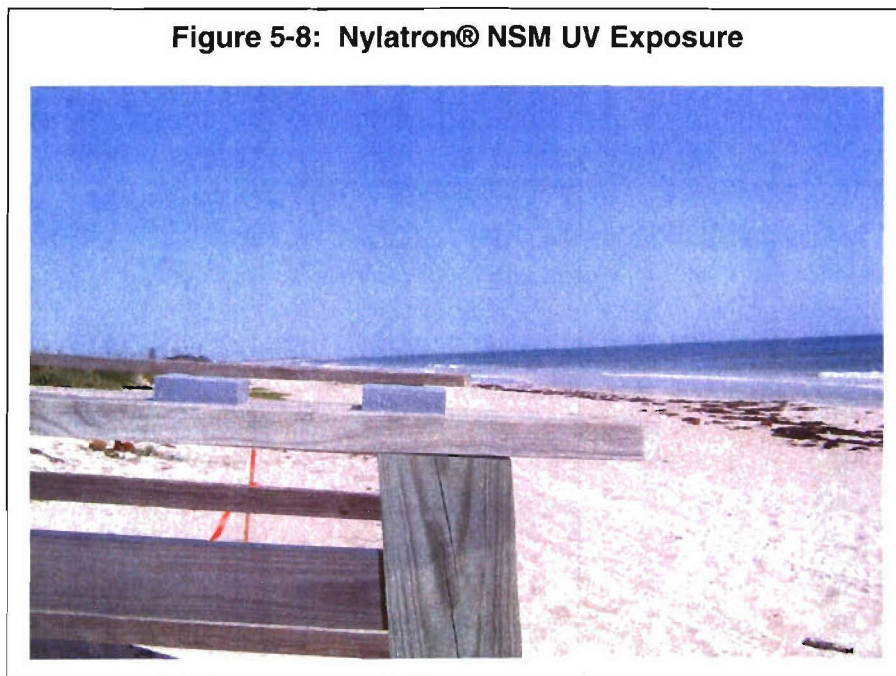

**Table 6: UV Exposure Results**

Physical Characteristics	Prior to UV Exposure	After 62 Days of UV Exposure
Length	3.5 in	3.5 in
Width	3.5 in	3.5 in
Depth	1.0 in	1.0 in
Weight	227 g	227 g

The data on this page are protected according to the data rights language provided on the title page of this document and can not be modified, reproduced, released or disclosed unless in accordance with terms on the cover page.

### 5.2.2 FTIR UV Exposure Results

EMPA and FTIR Spectroscopy were conducted on ten 20 mm by 20 mm by 2 mm thick samples that were cut from one Nylatron® NSM test section exposed to UV radiation. Figure 5-9 contains the EMPA results for the UV radiation exposed sample. This EMPA data is identical to the virgin and corrosion treated sample data contained in Figure 5-4. This indicates that UV radiation did not induce chemical changes. The FTIR Spectroscopy data contained in Figure 5-10 shows that no carbon or nitrogen bond changes resulted from UV radiation exposure.

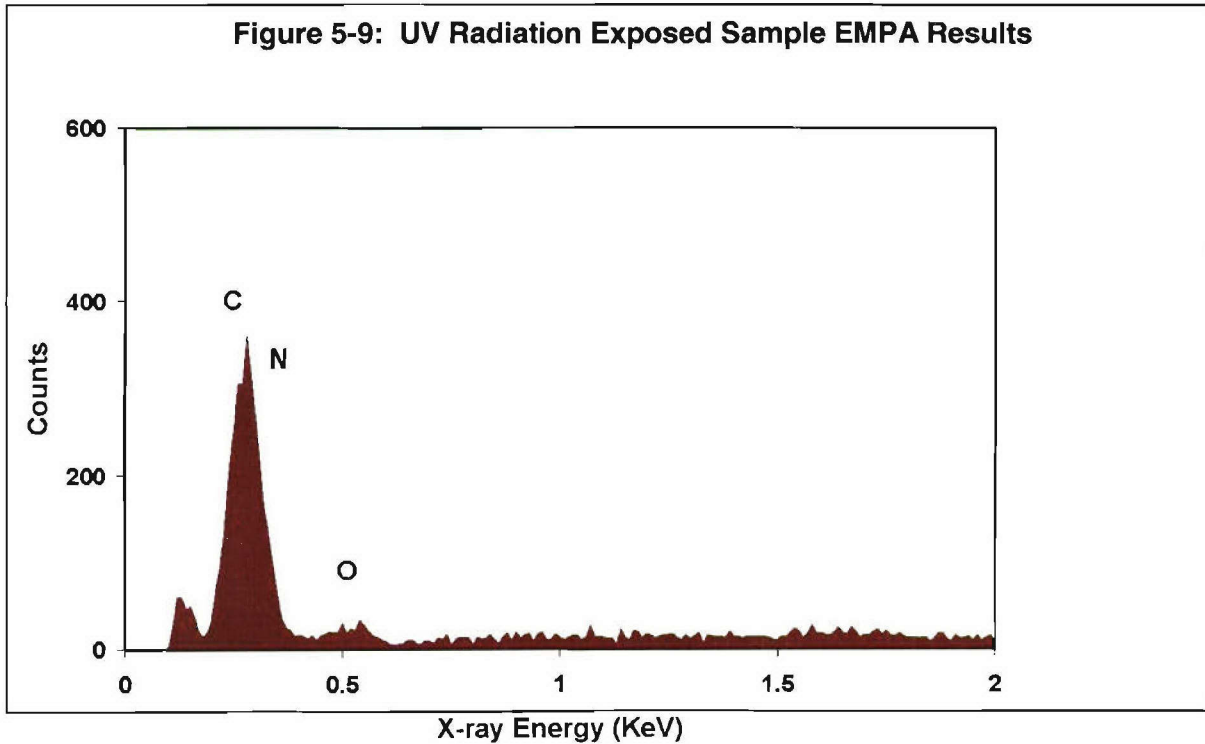
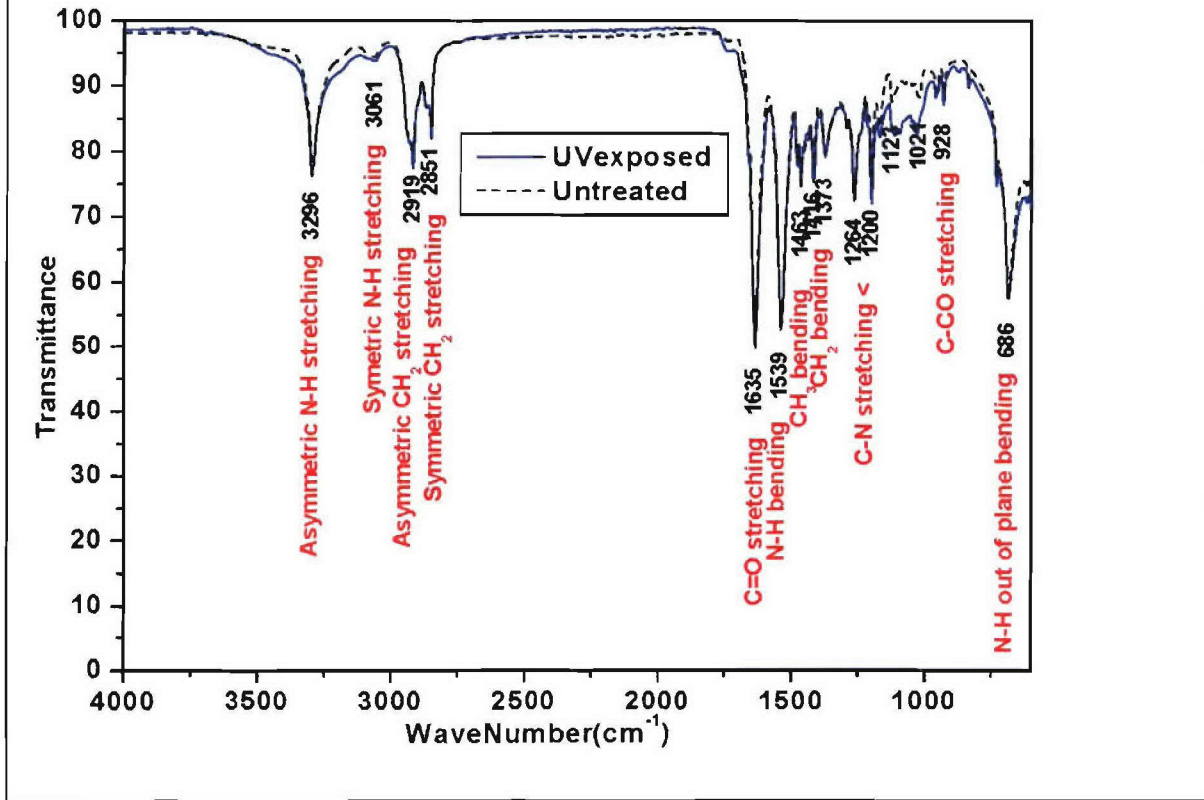

Figure 5-10: UV Radiation Exposed Sample FTIR Spectroscopy Results



### 5.3 Chemical Reactivity

Hardware installed on Navy ships may contact various chemicals used to operate and maintain the ship. The chock insert material may be exposed to fumes or spills, so it must be chemically inert. According to the Material Safety Data Sheet (MSDS), provided by Quadrant Engineering Inc. and found in Appendix A, Nylatron® NSM is inert.

## 6.0 Environmental

The US Navy has adopted a proactive policy for enhancing compliance with federal and international environmental regulations. Examples include Navy programs for hazardous waste minimization, pollution prevention, recycling, and application of technological advances that make materials more environmentally friendly. Thus, the Navy has implemented procedures to assess the environmental impact of all shipboard materials and equipment.

A particular environmental concern for a chock insert is material handling. Ideally, a disposable chock insert would require no special requirements for storage or disposal. Also, a chock insert must not negatively impact the environment if lost overboard. Nylatron® NSM consists of approximately 95% nylon and 5% proprietary paraffin lubricant. According to the Nylatron® NSM MSDS, neither of these constituents requires special tracking or handling. Therefore, the Nylatron® NSM two piece chock insert is not anticipated to negatively impact the environment should one be lost overboard.

A concern regarding plastics is the potential for cyanide gas (HCN) formation during fires. Cyanide gas is a combustion by-product of nitrogen-containing materials such as wool, silk, and plastics. The colorless gas is usually undetectable and highly toxic to humans by all routes of exposure (inhalation, physical contact, ingestion). Adult human inhalation of cyanide gas concentrations greater than 300 parts per million (ppm) can be fatal within minutes and lower doses can endanger life. The Occupation Safety and Health Administration (OSHA) Standard 29 CFR 1910 limits adult exposure to an 8-hour time weighted average of 10 ppm of contaminated air (11 milligrams per cubic meter of air).

HCN is produced when nitrogen-containing chemicals are burned. The Nylatron® NSM MSDS warns that HCN is released when Nylatron® NSM encounters temperatures above 572 degrees Fahrenheit. However, the concentration released when Nylatron® NSM reaches this temperature, given the application, is not known. Other polymers used on board Navy ships will also release HCN when burned. If the Navy considers HCN formation during fires a relevant risk, additional investigation will be conducted in Phase II.

## 7.0 Physical

Three (3) key pieces of data were obtained from the physical testing and analysis: Nylatron® NSM test section surface roughness after simulated mooring line abrasion; particle size distribution of particles created by wear testing; and deformation and structural integrity after cyclical load testing. These data were extracted from the tested sections through examination using a Scanning Electron Microscope (SEM), a high sensitivity scale and a surface roughness tester.

### 7.1 Surface Roughness and Preferential Wearing

A chock insert's primary function is to maintain a smooth mooring line contact surface which significantly reduces operational line wear. Ideally, an insert would provide a perfectly smooth line contact surface. The term "Surface Roughness" is used to quantify how smooth (or rough) a surface actually is. The US Navy has determined that an acceptable mooring line contact surface is one that maintains a surface roughness value of no more than 125 micro inches.

Because the mooring line exterior surface is inherently rough, chock insert surface wear is unavoidable. As wearing occurs, chock insert particulate matter is created. Significant particulate accumulation can potentially have negative effects. For example, excessive particulate matter could create mooring line rigging equipment binding issues, deck tripping hazards, and housekeeping concerns. The term used to qualitatively describe this wearing process is "preferential wear." An optimized chock insert intrinsically reduces this preferential wear to a minimum.

#### 7.1.1 Wear Testing

Five (5) Nylatron® NSM test sections of were sent to Micro Photonics Inc. in Irvine, California for testing using a Pin on Disk Tribometer (Model Number MT2/60/NI). This device operates by using a flat or a sphere shaped indenter loaded on to the test sample with a precisely known force. The indenter (a pin or a ball) is mounted on a stiff lever, designed as a frictionless force transducer. As the disk is rotated, resulting frictional forces acting between the pin and the disk are measured by very small deflections of the lever using a sensor. Wear coefficients for both the pin and sample are calculated from the volume of material lost during a specific friction run. This simple method facilitates the determination and study of friction and wear behavior of almost every solid state material combination. An illustration of the key Pin on Disk components is shown in Figure 7-1.

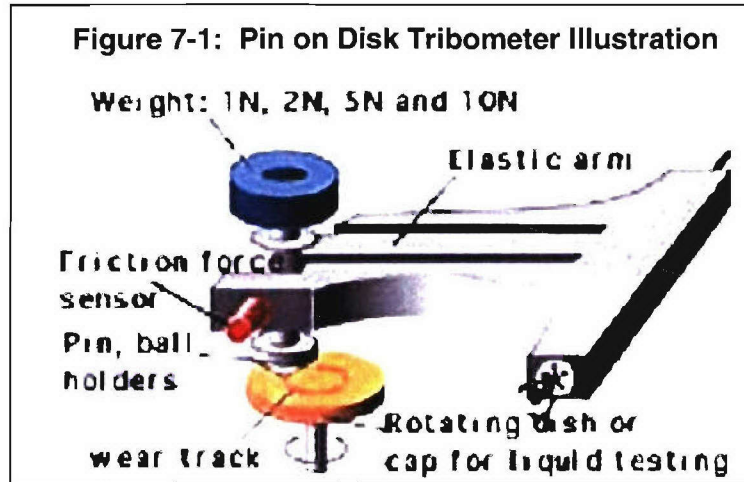

For this project, a section of mooring line was used as the indenter and a test section of Nylatron® NSM was used as the disk section. The actual setup is shown in Figures 7-2 and 7-3.

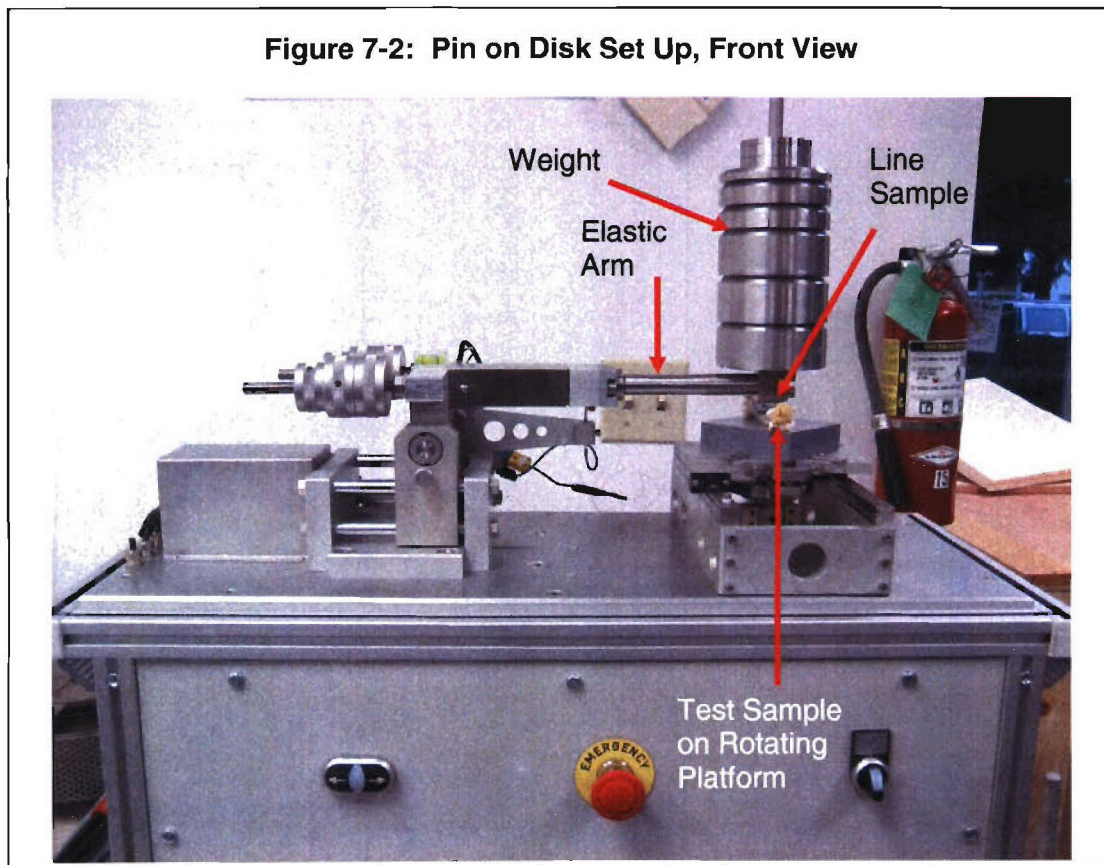

The data on this page are protected according to the data rights language provided on the title page of this document and can not be modified, reproduced, released or disclosed unless in accordance with terms on the cover page.

**Figure 7-3: Pin on Disk Set Up, Side Views**

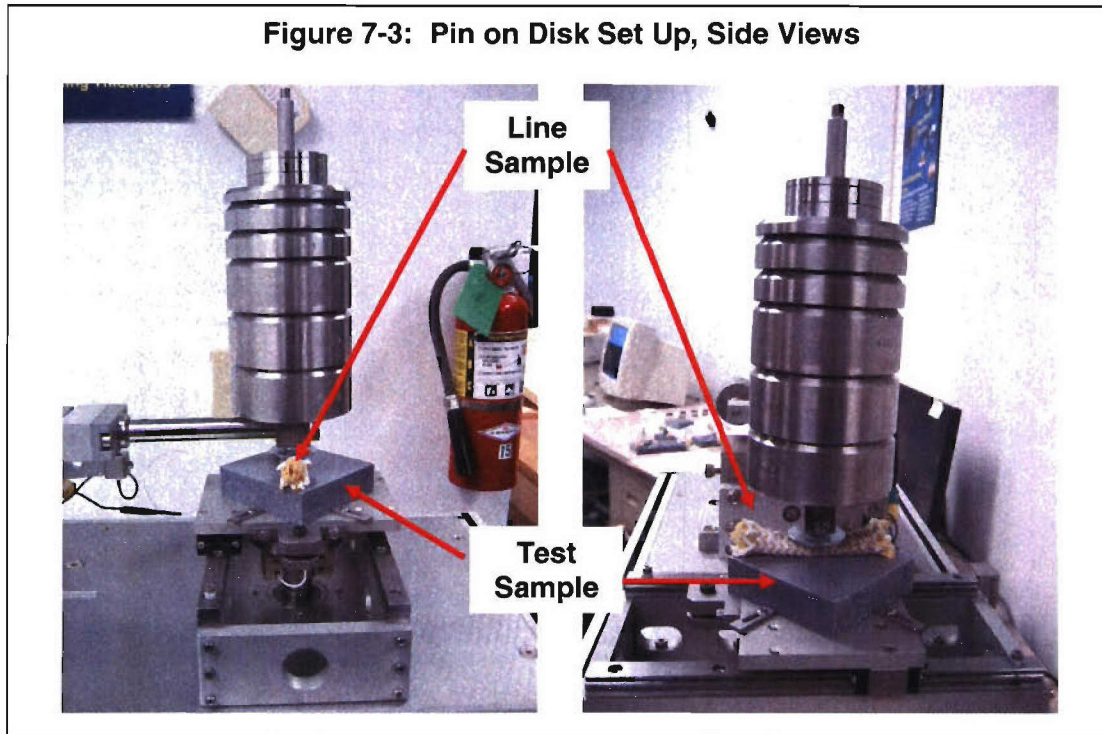

### 7.1.2 Results

According to USS The Sullivans ship personnel, the action of mooring lines running across the chock takes place primarily during docking, when the lines are being attached to the shore. This operation is done by hand and tension in the line is negligible. As the line is being secured around the capstan, line movement across the chock is diminished and tension increases in the line, thus the downward line induced force on the chock increases.

The weight used during this test was 90 Newtons (N) (the maximum load that the Tribometer could accommodate), which provided a downward pressure of 1300 pounds per square inch. Five (5) Nylatron® NSM samples were tested, rotating at the maximum speed setting, 400 rotations per minute (rpm), for three (3) hours. The maximum speed setting was chosen to achieve the most wear in the allotted time. Each section's surface roughness was measured prior to and after testing. Table 7 shows the surface roughness measurements prior to and after testing. The maximum surface roughness observed was 0.566 micro inches which is well below the allowable limit of 125 micro inches.

The Micro Photonics Statement of Work required collection of all particulate matter from the abrasion testing so that a particle analysis could be completed. However, Micro Photonics reported that so few particles (and no dust) were generated that they were impossible to collect. Thus, no particle weights or particle size distribution analyses were performed. However, lack of particle generation under abrasive conditions indicates Nylatron® NSM's suitability for a chock insert material.

Table 7: Wear Testing Results		
Sample	Surface Roughness Prior to Pin on Disk Testing (micro inches)	Surface Roughness After Pin on Disk Testing (micro inches)
1	0.295	0.324
2	0.295	0.566
3	0.295	0.337
4	0.295	0.347
5	0.295	0.398

## 7.2 Strength

Securing massive Navy ships to port creates large mooring line tension forces that are transferred into compressive loads on the steel chocks. As tidal conditions cause a ship to rise and fall, these compressive loads are increased and decreased. An effective chock insert must continue to provide a smooth mooring line contact surface while transferring these loads into the chock.

The compressive stress encountered by the chock insert is a function of mooring line applied force and line contact surface area. Equation 1 is used to calculate the applied stress ( $\sigma_c$ ).

**Equation 1**      
$$\sigma_c = \frac{F_c}{A}$$

where:

$A = \text{line contact area} = \text{arclength} \times \text{rope diameter}$

$F_c = \text{mooring line tension force component directed into the chock}$

$$\text{arclength} = K \times \frac{\pi}{2}$$

and  $K = \text{chock curvature radius}$ .

A three dimensional view of the contact area is shown in Figure 7-4.

**Figure 7-4: Mooring Line Contact Area**

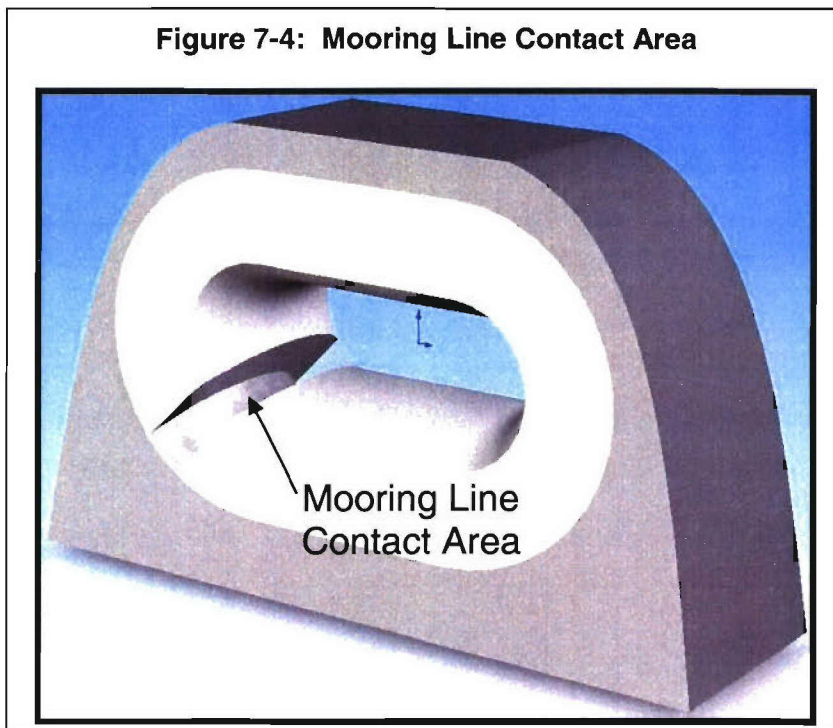

Assuming 100% of the mooring line tension transfers normally into the chock provides a worse case compressive stress estimate. The maximum tension load that the mooring line is known to encounter during operation is 100,000 pounds (force). The US Navy requires that mooring lines withstand 100,000 pounds (force) times a safety factor of three (3). Therefore, maximum mooring line tensile strength used onboard Class DDG Navy ships is 300,000 pounds (force).

Figure 7-5 shows the linear relationship for a range of applied mooring line compressive forces.

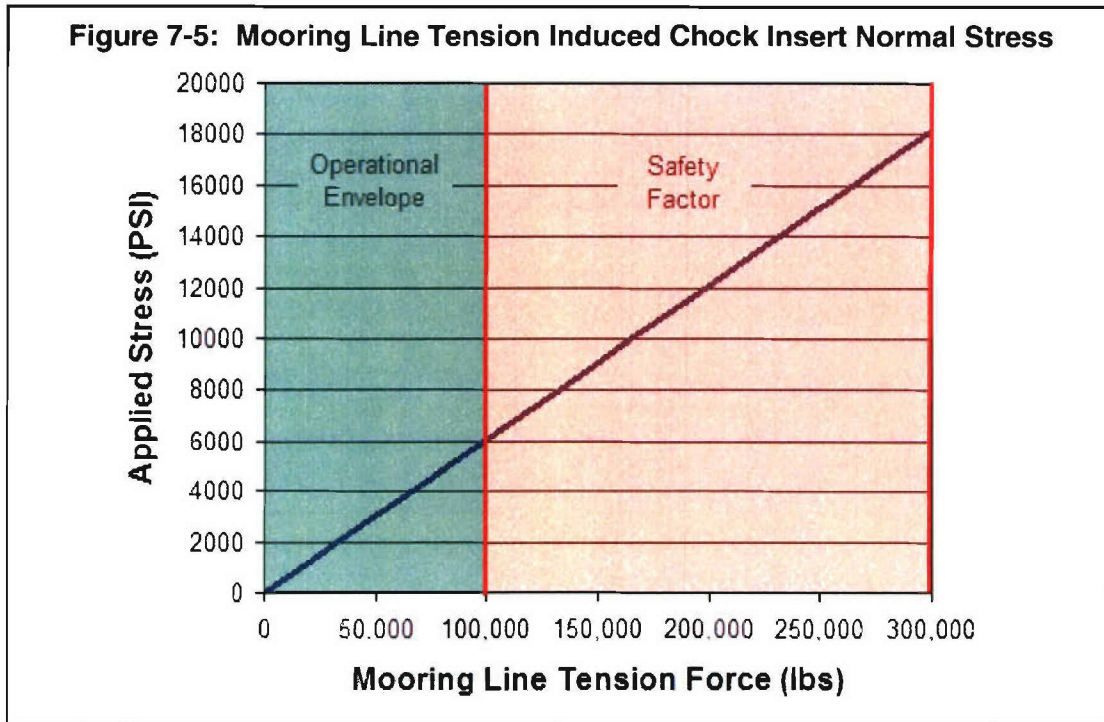

The area (A) in Equation 1 is calculated by setting K equal to 4.5 inches and the line diameter to 2.33 inches. This yields a line surface contact area of 16.5 square inches. At 100,000 pounds of mooring line tension, the compressive stress is calculated to be approximately 6,100 pounds per square inch (psi).

A finite element analysis (FEA) model of the chock and insert was constructed to provide additional insight into the chock's compressive load reaction under various loading scenarios. This FEA model employed a Voronoi-Delaunay mesh using a four point Jacobian check and solved using a direct sparse solver. The mesh is composed of 7458 parabolic tetrahedral elements and 11900 nodes which resulted in 34083 degrees of freedom. Each solid element in this meshing scheme has ten nodes: four corner nodes and one node at the middle of each edge (a total of six mid-side nodes). Each surface element has six nodes: three corner nodes and three mid-side nodes.

The Voronoi-Delaunay mesh is a commonly used meshing method known for its speed and accuracy. The Jacobian check prevents tetrahedral elements from excessive distortion which is critical for curved and sharp geometries. The Jacobian ratio at a point inside the element provides the degree of element distortion at that exact location. As the edge curvatures increase, the Jacobian ratio also increases. The Jacobian ratio of a parabolic tetrahedral element with all mid-side nodes exactly in the middle of the straight edges is 1.0. Stochastic studies have shown that a Jacobian Ratio of 40 or less is acceptable<sup>1</sup>. The FEA program calculates the Jacobian ratio at the selected number of Gaussian points for each tetrahedral element. It then adjusts the locations of the mid-side nodes of distorted elements automatically so all elements pass the Jacobian check.

<sup>1</sup> Cook, R.D.; Malkus, D.S.; Plesha, M.E.; and Witt, R.J. *Concepts and Applications of Finite Element Analysis*. Section 11.4-6.

The data on this page are protected according to the data rights language provided on the title page of this document and can not be modified, reproduced, released or disclosed unless in accordance with terms on the cover page.

The insert was given a one (1) inch thickness based upon functionality requirements. Figure 7-6 shows the mesh and the FEA model calculated stress distribution given 100,000 pound mooring line tension.

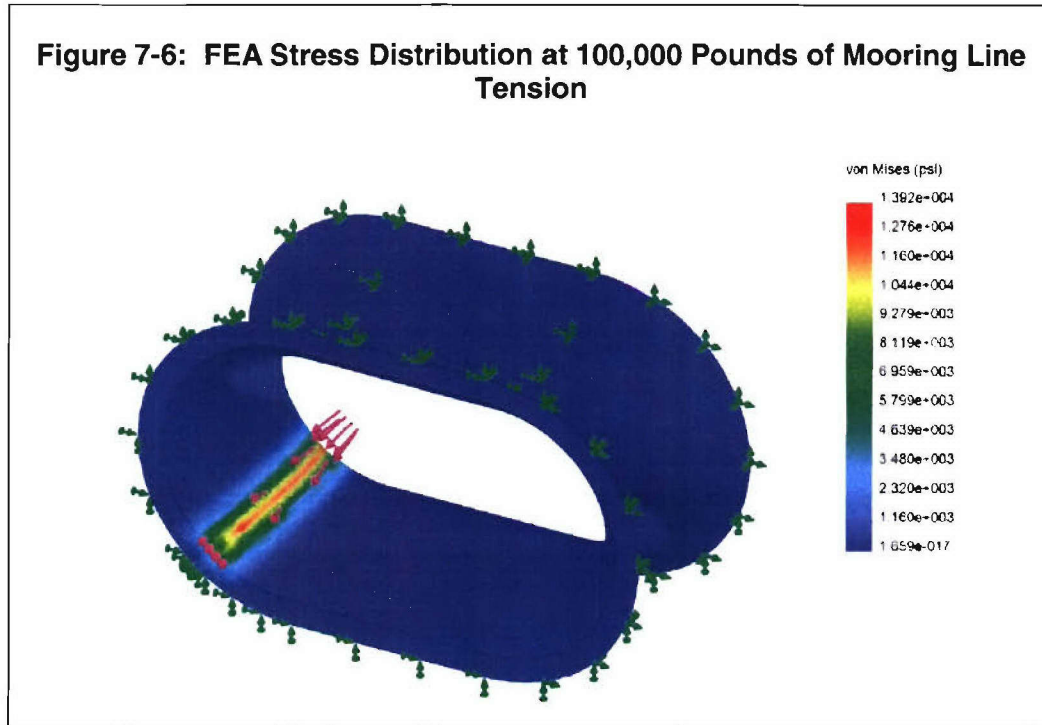

Figure 7-6 shows that the Von Mises stress ranges from approximately 6,000 psi at the edges to approximately 11,000 psi in the center. The Von Mises stress is derived from the distortion energy theory and is a simple way to combine three dimensional stresses to calculate ductile material failure criteria. The Von Mises stress provides a scalar function of the stress tensor components or an overall magnitude of the tensor. This allows the onset and amount of plastic deformation under triaxial loading to be predicted from the results of a simple uniaxial tensile test.

At any given point, two orthogonal planes can be found that have no shear stress. These planes are known as the Principal Planes. Principal Stresses are the stresses that are normal to the Principal Planes. The Von Mises stress is related to the principal stresses and mathematically represented by Equation 2.

**Equation 2**

$$\sigma_v = \sqrt{\frac{(\sigma_1 - \sigma_2)^2 + (\sigma_2 - \sigma_3)^2 + (\sigma_3 - \sigma_1)^2}{2}}$$

In Equation 2,  $\sigma_v$  is the Von Mises stress and  $\sigma_1$ ,  $\sigma_2$ , and  $\sigma_3$  are the principal stresses in three (3) dimensions. The Von Mises stress is extremely useful for evaluating the plastic deformation

The data on this page are protected according to the data rights language provided on the title page of this document and can not be modified, reproduced, released or disclosed unless in accordance with terms on the cover page.

of materials. Yielding occurs when the Von Mises stress reaches the material yield stress determined from uniaxial loading.

The FEA loading simulation assumes that the line keeps a perfectly cylindrical shape as it wraps around the chock edge. This explains why the higher stress concentration is seen in the contact area center. A variety of factors such as age of the line, angle of the rope to and from the chock, and tension in the line contribute to the actual shape that the line takes along the contact area. During a mooring line inspection onboard the USS The Sullivans, several mooring lines were observed while in use. It was noted that the loaded mooring lines slightly flatten, providing a chock contact surface area width that is slightly larger than the line diameter. Figure 7-7 shows how mooring lines flatten out around the chock edge when in use.

**Figure 7-7: Mooring Line Flattening Around Chock**

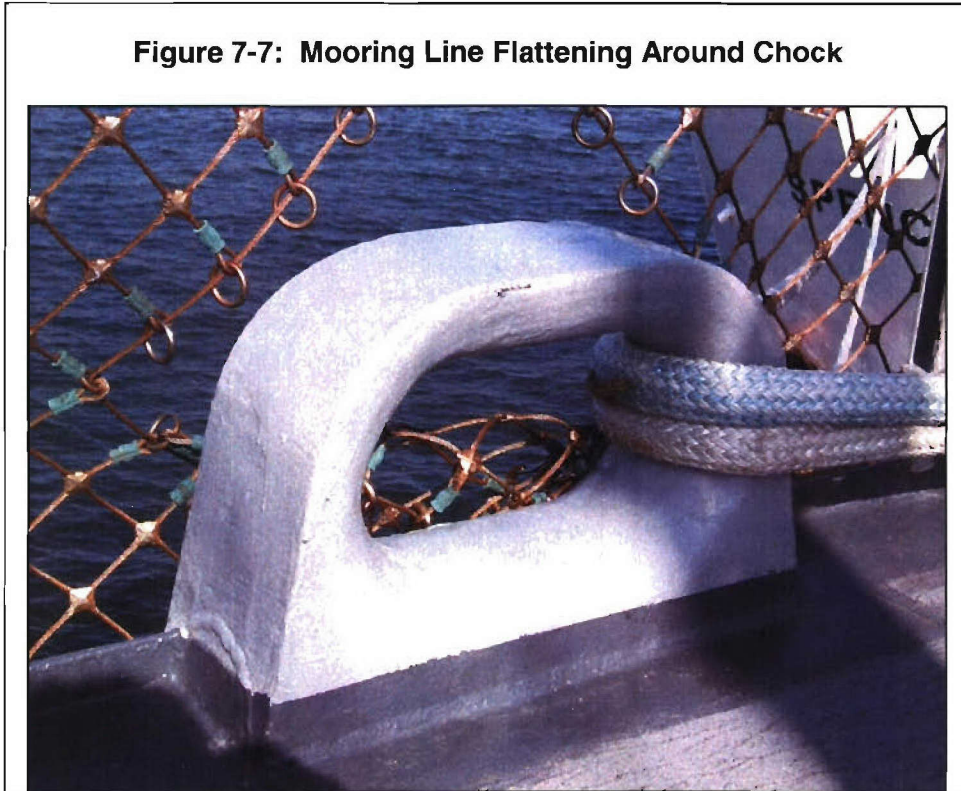

Based on this observation, as mooring line tension is increased, the contact surface area will slightly increase to a maximum value. Generally, the assumption was made that the contact area width will be equal to the line diameter (as assumed in the Equation 1 hand calculation method).

Since a chock insert will be in constant contact with the mooring line, the insert's behavior when subjected to forces that exceed the mooring line operational envelope must be investigated. A cylindrical FEA model is used to consider a worst case scenario. Figure 7-8 shows the same FEA model subjected to a line tension of 300,000 pounds (force) to account for the line's safety factor.

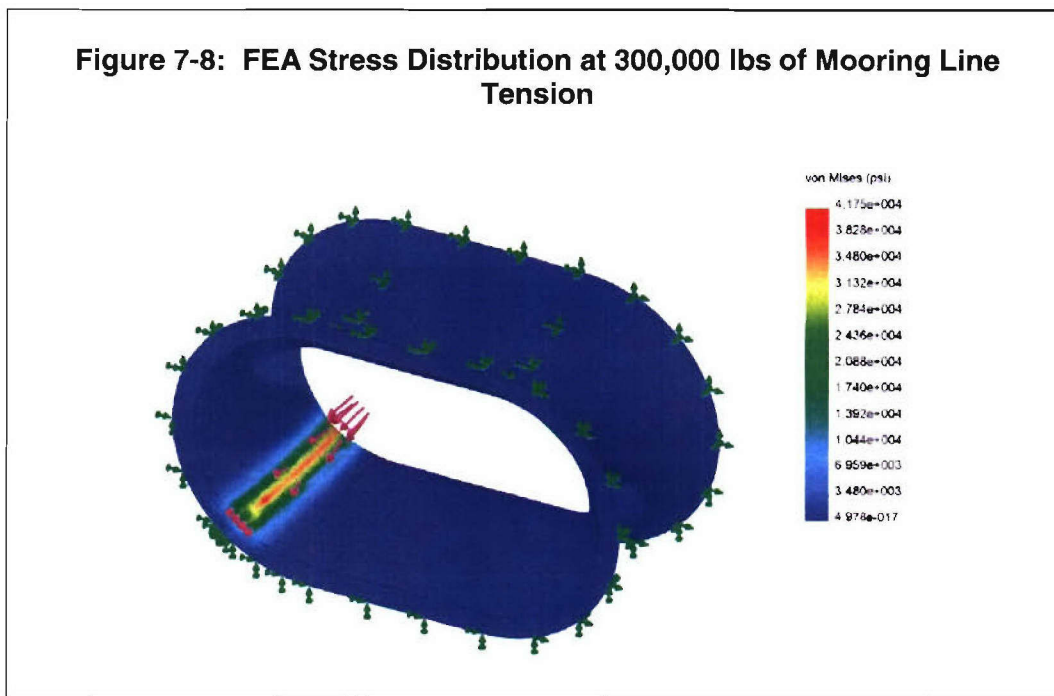

As expected, the applied stress increased to approximately 18,000 psi on the outer contact area edges and to approximately 36,000 psi in the center.

The Nylatron® NSM is expected to deform completely elastically until encountering stresses above approximately 12,000 psi. This information is taken from a Nylatron® MC907 stress strain curve, which was provided by the material manufacturer and is shown below in Figure 7-9. The material manufacturer stated that Nylatron® NSM is expected to perform very similar to Nylatron® MC907. The manufacturer did not have actual Nylatron® NSM data. However, the actual Nylatron® NSM material structural behavior was determined by load tests conducted during this Phase I and presented in Sections 7.2.1 and 7.2.2.

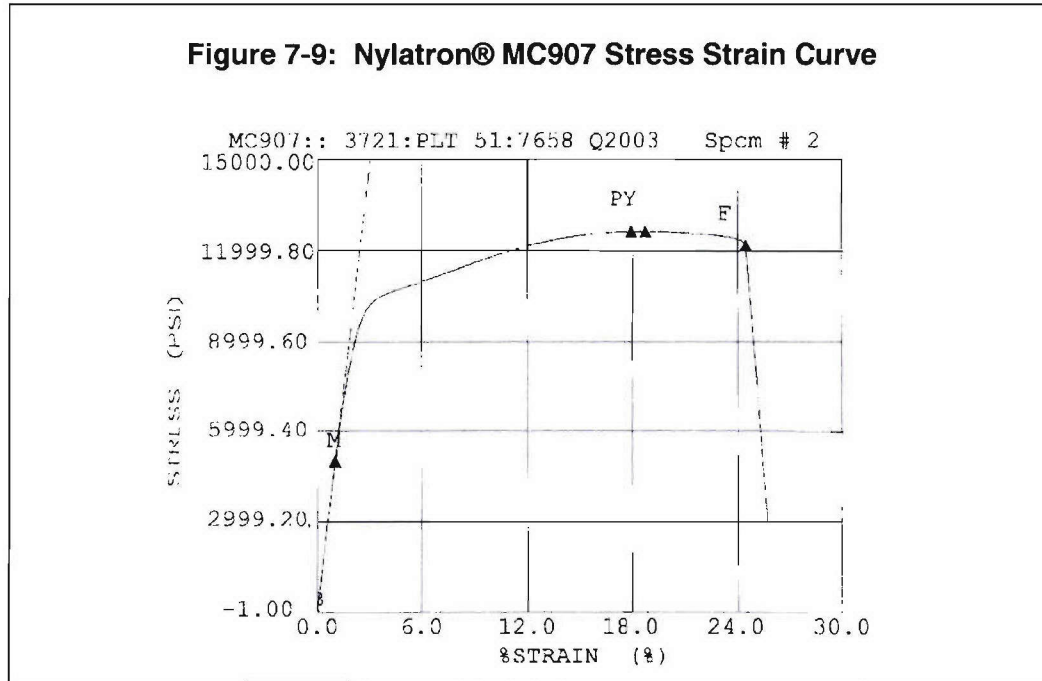

According to this curve, Nylatron® behaves elastically (very little deformation) until stresses of approximately 10,000 psi are encountered. The material then will deform plastically until approximately 12,500 psi, at which point the material no longer resists loading. Combining this analysis with the relationship in Figure 7-5 shows that a Nylatron® NSM chock insert can be expected to withstand mooring line tension loads up to approximately 225,000 pounds with minor plastic deformation possibly occurring in areas of high stress concentration. However, loads above this value will cause severe plastic deformation of the chock insert. The chock will still be capable of continuing to provide abrasion reduction between the chock and mooring lines but will be physically altered. Additional discussion of deformation and failure is in Section 7.2.2.

### 7.2.1 Cyclical Load Testing

To verify that Nylatron® NSM will hold up to normal tidal conditions, Nylatron® NSM test sections were subjected to cyclical load testing. Ten (10) test sections (1.76 inch by 1.76 inch by 1 inch thick) were load tested in a closed loop servo controlled hydraulic press system (Machine Number 60005) with a 100,000 pound force capacity. This test was performed by Metcut Inc. in Cincinnati Ohio. To simulate normal sea conditions, these sections were loaded at a constant rate of 1000 psi per minute to a pressure of 10,000 psi and that pressure was held constant for one minute. The pressure was then dropped at a constant rate to 6,000 psi and that pressure was held for one minute. The pressure was then increased at a constant rate to 8,000 psi and held for one minute. Hydraulic press mounted sensors measured each sample's top surface displacement every 0.2 seconds during the entire loading process. The load was then removed from the test sections at a constant rate. Figure 7-10 shows the load versus time curves and Figure 7-11 shows displacement versus time.

**Figure 7-10: Load versus Time**

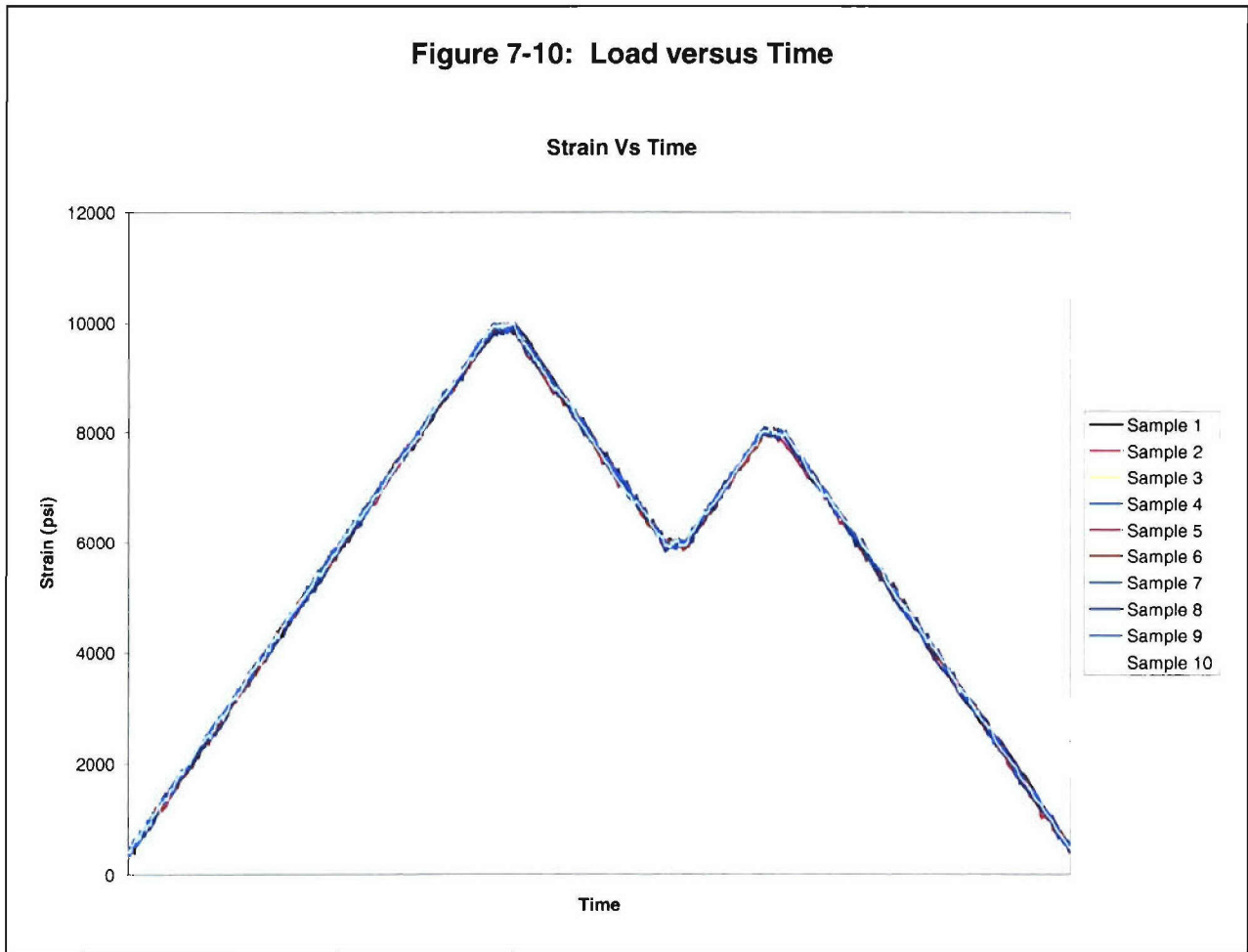

The data on this page are protected according to the data rights language provided on the title page of this document and can not be modified, reproduced, released or disclosed unless in accordance with terms on the cover page.

**Figure 7-11 Displacement versus Time**

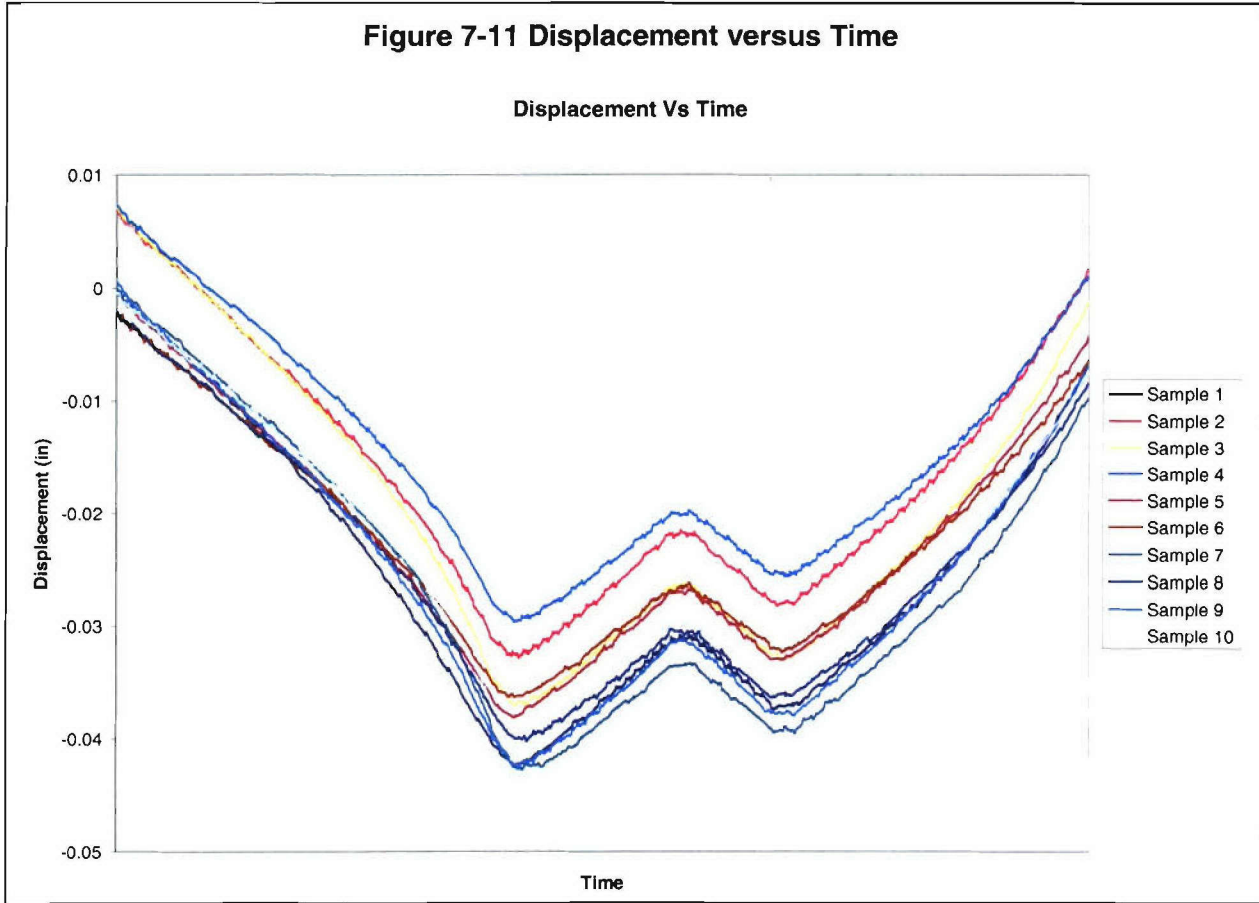

Test data shown in Table 8 indicate the average displacement after one complete loading cycle was 0.005 inches. This means Nylatron® NSM performed elastically when subjected to loads within the application operational envelope (mooring line tension force under 100,000 pounds). This remains true as the load is varied continuously over the test cycle time.

<b>Table 8: Cyclical Load Test Results</b>	
Sample	Total Deflection (in)
1	0.003
2	0.009
3	0.006
4	0.004
5	0.003
6	0.003
7	0.006
8	0.005
9	0.005
10	0.006
Average	0.005

The data on this page are protected according to the data rights language provided on the title page of this document and can not be modified, reproduced, released or disclosed unless in accordance with terms on the cover page.

Following cyclical load simulation, the test sections were sent to the UCF AMPAC laboratory to be examined under an SEM. Images taken with the SEM are shown in Figure 7-12.

**Figure 7-12: Scanning Electron Microscope View of Cyclical Loading**

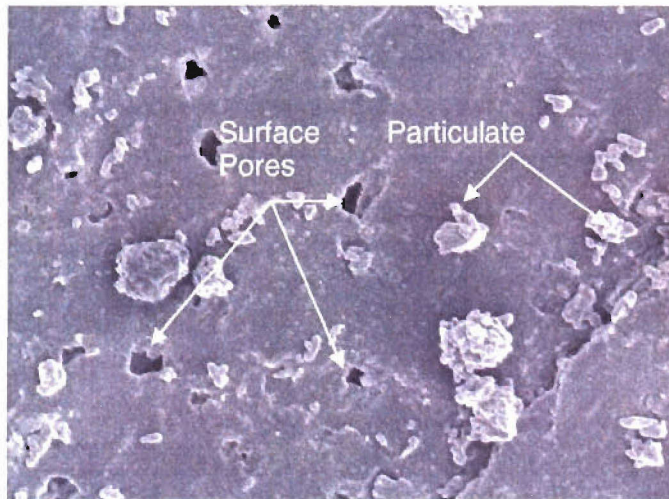

5000x Magnification

The images show surface pores and particulate no larger than 1 to 2 nanometers and distributed evenly over the sample. No indications of major structural deficiencies are observed and the material appears fundamentally the same as the SEM image of a virgin Nylatron® sample (Figure 7-13).

**Figure 7-13: Scanning Electron Microscope View of Virgin Nylatron® NSM**

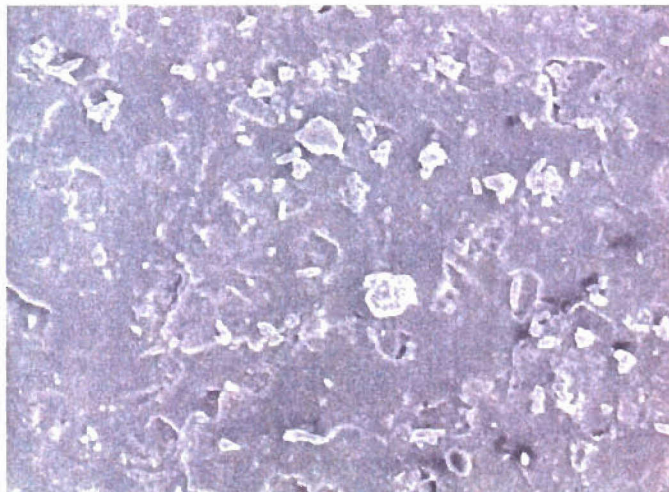

5000x Magnification

The data on this page are protected according to the data rights language provided on the title page of this document and can not be modified, reproduced, released or disclosed unless in accordance with terms on the cover page.

## 7.2.2 Failure Testing

As discussed in Section 7.2, a Nylatron® NSM insert would deform when tension in the mooring line exceeds the operational envelope (mooring line tension force over 100,000 pounds). Since this insert is meant to be replaceable, constant plastic deformation with no cracks that could cause mooring line damage is considered preferential failure. Events that cause mooring line tension to exceed 100,000 pounds are not typical, so even if chock inserts require replacing after such an event, overall savings on line damage would still be achieved.

The closed loop servo controlled hydraulic system was used to examine the behavior of Nylatron® NSM test sections when pressure was constantly increased to a point of failure. Four (4) test sections (1.76 inch by 1.76 inch by 1 inch thick) were loaded until the material no longer resisted the pressure applied by the hydraulic press and began to deform. The results are shown in Figure 7-14.

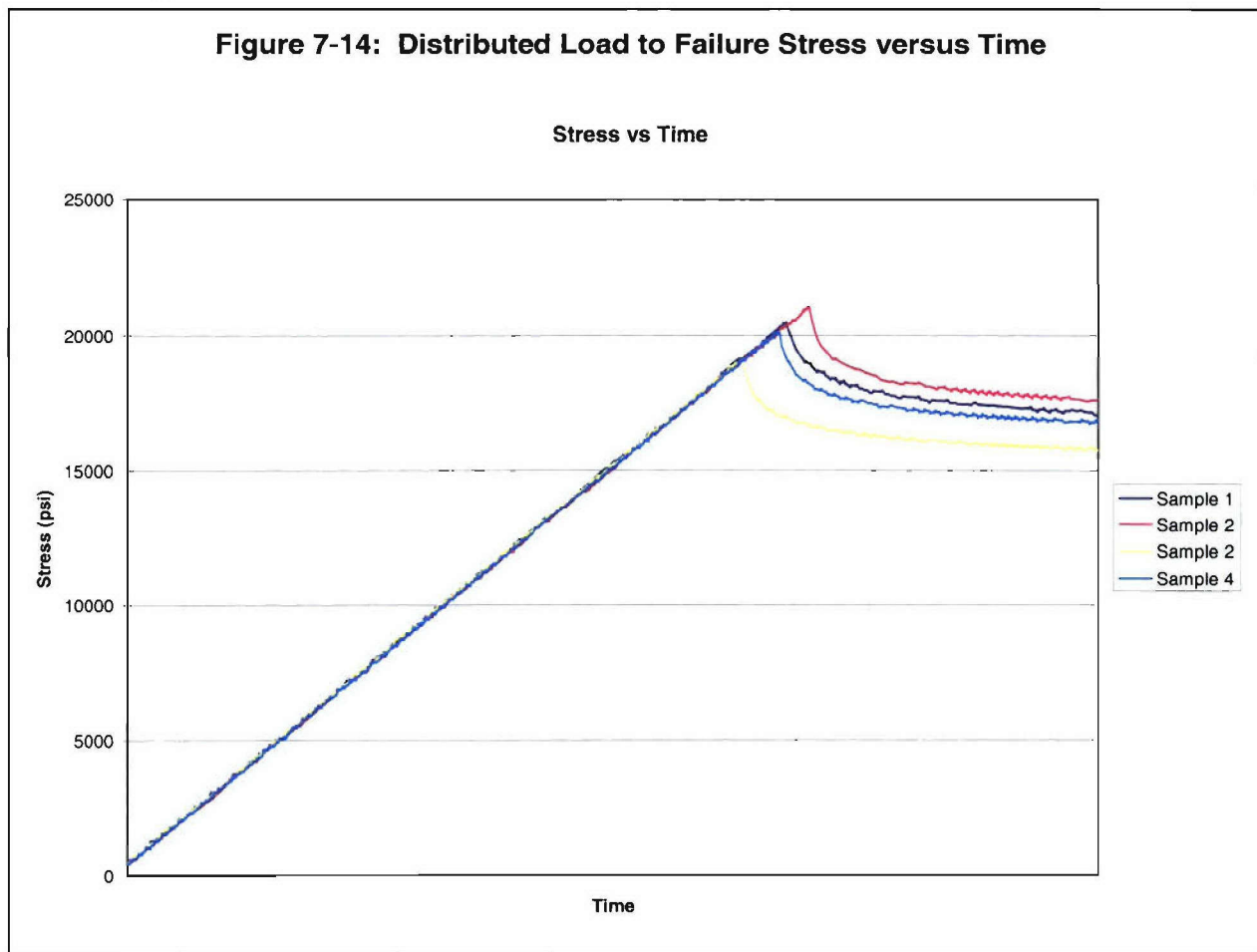

The data show that the Nylatron® NSM samples yielded between approximately 19,000 and 21,000 psi. This is higher than the 14,000 psi yield strength quoted by the material manufacturer, however Quadrant did not have actual data on Nylatron® NSM and based their yield strength on similar materials.

The data on this page are protected according to the data rights language provided on the title page of this document and can not be modified, reproduced, released or disclosed unless in accordance with terms on the cover page.

Following deformation, the test sections were then sent to the UCF AMPAC laboratory to be examined under a scanning electron microscope, shown in Figure 7-15. No structural deficiencies were observed.

**Figure 7-15: Scanning Electron Microscope View of Distributed Load Plastic Deformation**

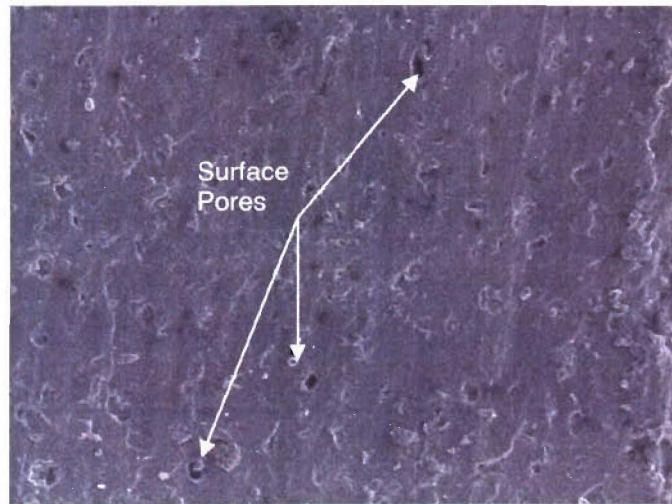

2500x Magnification

No visual signs of Nylatron® NSM surface cracking or deformation were noted on the yield strength test samples, as shown in Figure 7-16.

**Figure 7-16: Test Section Surface after Distributed Load to Failure Testing**

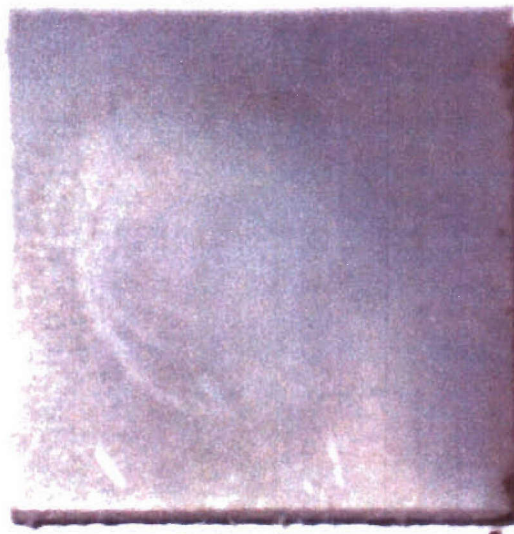

The data on this page are protected according to the data rights language provided on the title page of this document and can not be modified, reproduced, released or disclosed unless in accordance with terms on the cover page.

The failure load test assumes that under maximum loading, the mooring line would flatten and provide a larger surface contact area. To examine the behavior of Nylatron® NSM under a concentrated cylindrical load, a 2.5 inch diameter pin was placed over a Nylatron® NSM test section and a load was applied. The load was constantly increased until the material's yield point was reached. Figure 7-17 shows a photograph of the test configuration and Figure 7-18 shows the resulting strain versus time relationship.

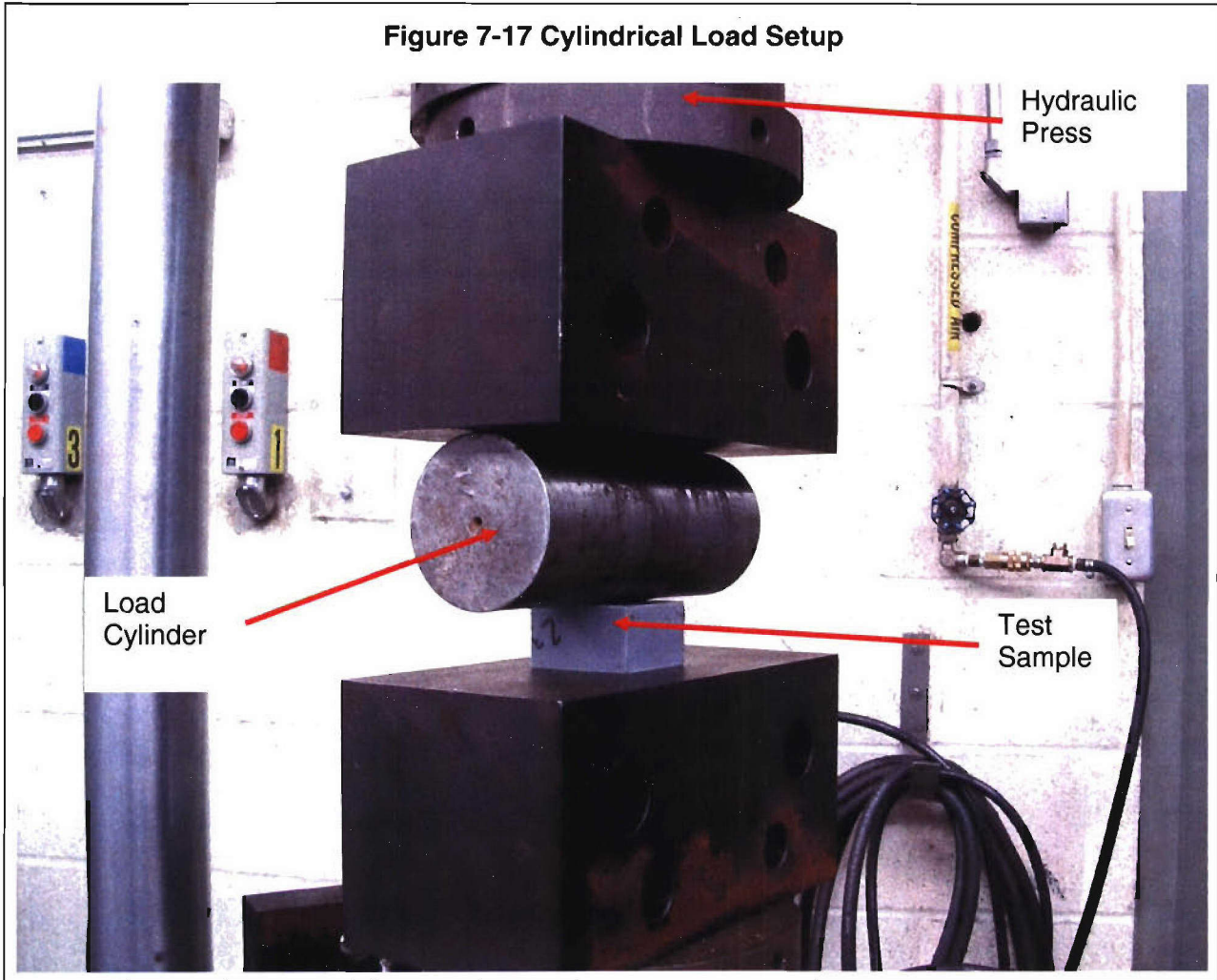

The data on this page are protected according to the data rights language provided on the title page of this document and can not be modified, reproduced, released or disclosed unless in accordance with terms on the cover page.

**Figure 7-18: Cylindrical Load to Failure Stress versus Time**

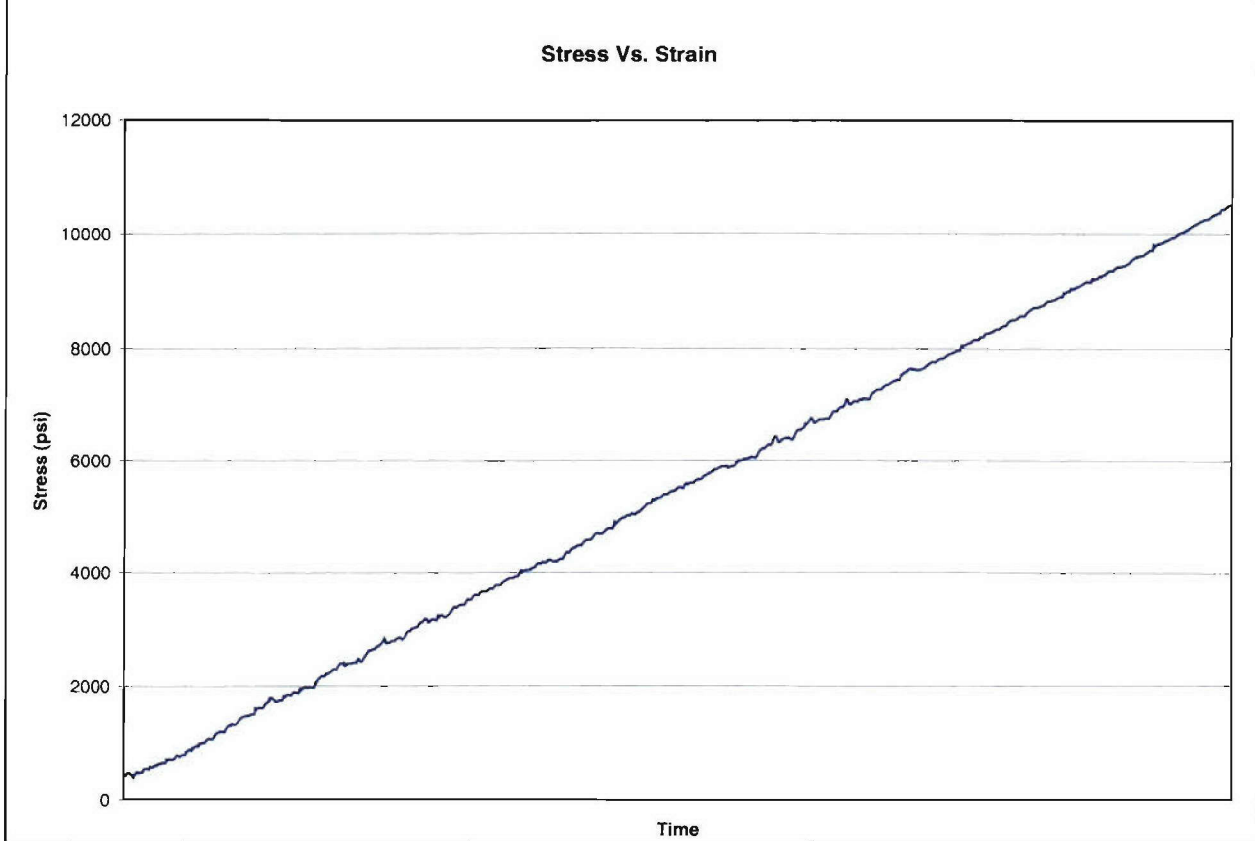

Under a concentrated cylindrical load, the one (1) inch thick test sample failure point was approximately 10,521 psi. As with the distributed load, no stress fractures were visually found (Figure 7-18). This test section was also taken to the UCF AMPAC Laboratory and examined under a scanning electron microscope (Figure 7-20). Minor surface cracking was observed in the plastic deformation area under extreme magnification. These cracks are less than one (1) nanometer deep and do not indicated structural instability.

**Figure 7-19: Test Section Surface after Cylindrical Load to Failure Testing**

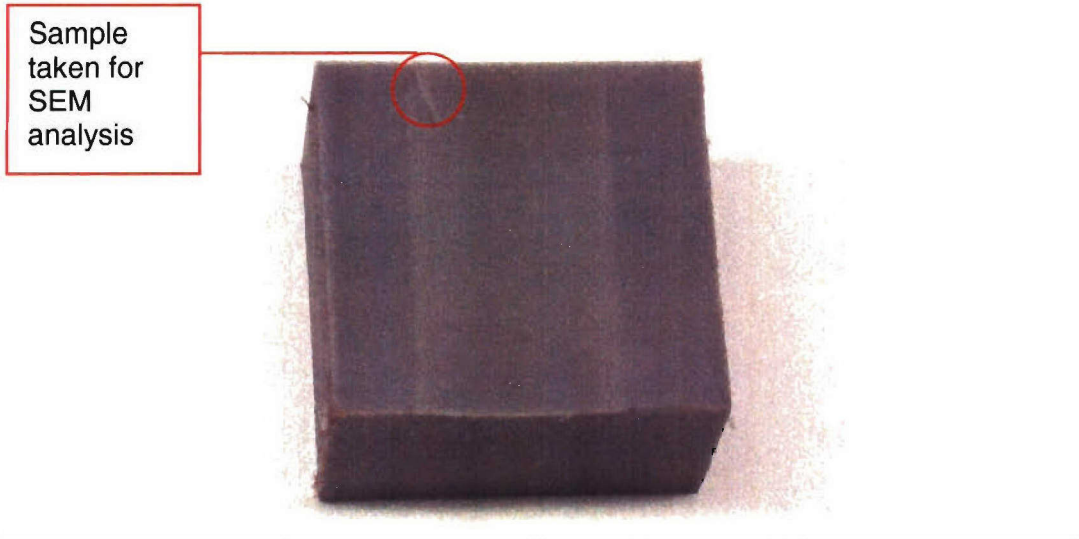

**Figure 7-20: Scanning Electron Microscope View of Distributed Load Plastic Deformation**

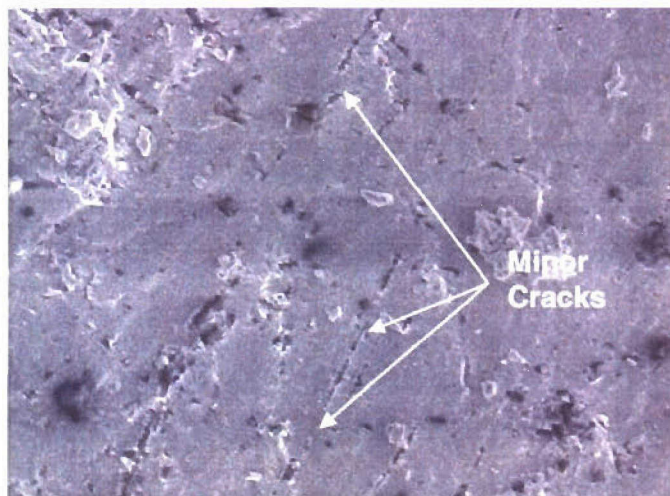

**5000x Magnification**

These data show that if the mooring line tension was to exceed the operational envelope (100,000 pounds) and increase into the mooring line safety factor realm, the Nylatron® NSM insert would permanently deform, but continue to provide a smooth mooring line contact surface. The insert would be permanently deformed, but would not damage the mooring line.

The data on this page are protected according to the data rights language provided on the title page of this document and can not be modified, reproduced, released or disclosed unless in accordance with terms on the cover page.

### 7.3 Color

The stock Nylatron® NSM color is gray, similar to the paint color used onboard the Class DDG Navy ships. Other Nylatron® NSM colors can be custom produced. This requirement is satisfied inherently by the material.

## 8.0 Functional

Three (3) functional requirements were considered to ensure that the two piece chock insert design meets the Navy's needs. These requirements address the design itself and include geometry, production cost and attachment method.

### 8.1 Inner Diameter

The chock insert must be designed so that it does not hinder the chock functionality. Chock geometry allows several mooring lines to be passed through the chock at once. An overly thick insert design would not be able to accommodate several mooring lines. Because the Nylatron® NSM has such a high wear resistance and exhibits extremely elastic behavior under normal loading conditions, a thin insert is allowed. The insert prototype is being designed with a one (1) inch thickness because this provides ample room for chock functionality and attachment method design flexibility.

### 8.2 Cost

The Navy's concern regarding increasing mooring line replacement cost is the primary motivating factor for replaceable chock insert development. The current cost of a single new mooring line (per White Hill Manufacturing Co.) is approximately \$4000. A typical Destroyer has approximately 20 lines onboard and these lines currently need to be replaced after approximately 18 months. This translates to an annual mooring line replacement expense of approximately \$53,333 per ship. Extrapolating this estimate to encompass the entire 87 ship fleet, the Navy's total annual mooring line replacement cost for Destroyers is approximately \$4,640,000.

The Navy visualizes an inexpensive replaceable chock insert that will increase mooring line life to approximately 5 (five) years. Using the assumptions above, the proposed mooring line life extension will reduce the Navy's annual mooring line replacement expense to \$1,392,000 (a 70% reduction). Therefore, Nelson Engineering Co. focused on developing the most affordable chock insert solution that could feasibly meet all design requirements. Nylatron® NSM was selected as the most viable material for this application because it is inexpensive and its unique combination of properties potentially satisfies all other insert material requirements.

A Nylatron® NSM chock insert can be rapidly fabricated using one of two methods:

- APC (Atmospheric Pressure Cast)
- RIM (Reaction Injection Molding)

APC requires liquid Nylatron® monomer to be poured into a heated open mold where a chemical reaction takes place resulting in the nylon product. The mold is typically made from sheet or machined aluminum depending on part complexity. APC provides parts within tolerances of 1% and some porosity may be evident on select surfaces. This molding process is most cost effective for part quantities on the order of 25 to 100 units.

RIM requires liquid Nylatron® monomer to be injected into a closed, heated mold where the chemical reaction occurs resulting in the final nylon product. All RIM molds are made of

The data on this page are protected according to the data rights language provided on the title page of this document and can not be modified, reproduced, released or disclosed unless in accordance with terms on the cover page.

machined aluminum. RIM achieves part tolerances that are slightly lower than those achieved in the APC process. A RIM fabricated product will have minimal porosity throughout the part. This process is most cost effective for part quantities of 100 to 1,000 units.

Quadrant Engineering Co. provided Nelson Engineering Co. costs for fabricating the two-piece chock insert using both APC and RIM methods. Each method requires initial mold construction and material costs. The APC method also requires minor finish machining costs. The costs for each fabrication method are contained in Table 9.

<b>Table 9: Nylatron® NSM Chock Insert Fabrication Costs</b>		
	APC	RIM
Mold Construction	\$6,000.00	\$11,500.00
One Molded Insert (Includes Both Insert Pieces and Material)	\$900.00	\$432.00

Both fabrication methods require a mold to be constructed and Quadrant Engineering Co. manufacturing engineers estimate each mold to cast approximately 3,000 parts before needing replacement. Because the RIM method does not require finish machining, higher part numbers can be fabricated more quickly and more cost effectively. Thus, RIM is the recommended chock insert fabrication method for the chock insert application.

A rough order of magnitude cost savings estimate was developed to ensure adequate program savings. This estimate will be much more refined in Phase II. Chock insert fabrication costs along with approximate costs for attachment hardware, packaging, shipping, spare part storage and installation labor allow the total annual chock insert program cost to be estimated. Four (4) attachment pins are needed to attach each insert. One (1) dollar (\$1) per pin was used in the cost estimate, however a Phase II detailed study will examine the proper insert pin fabrication material and a more accurate cost will be determined. The shipping, storage and installation labor costs are known to be minor and thus can be assumed to be percentages of the total program cost. Shipping costs were assumed to be equal to 10% of the total fabrication costs, packaging costs were assumed to be 20%, storage costs were assumed to be 15% and installation labor was assumed to be 10%. Overhead, General and Administrative (G&A) expense and profit was assumed at 25% of total cost. Last, the number of years that a typical insert will continue to meet all specified requirements was estimated. The results obtained in this Phase I study suggest that a Nylatron® NSM insert will continue to perform unhindered in a harsh marine environment and under normal operating loading conditions for over 5 (five) years. A more advanced Phase II study is proposed to determine a more precise chock insert life cycle cost estimate.

Using the RIM fabrication method cost figures and assuming 87 Destroyer ships (each having 24 chocks) will be outfitted with chock inserts, Table 10 details the annual program cost estimate.

<b>Table 10: Annual Nylatron® NSM Chock Insert Program Component Cost Estimation (RIM Fabrication Method and 5 Year Useful Life Expectancy)</b>	
<i>Fabrication Costs</i>	
Mold Construction	\$2,300
2088 Two-Piece Chock Inserts	\$75,168
313 Spare Two-Piece Chock Inserts (15% of Operating Total)	\$11,268
<i>Fabrication Costs Subtotal</i>	\$88,736
<i>Other Program Costs</i>	
9604 Pins (4 Pins Per Insert)	\$9,604
Packaging	\$17,747
Shipping	\$8,874
Storage	\$13,310
<i>Other Program Costs Subtotal</i>	\$49,535
<i>Subtotal</i>	\$138,271
<i>Overhead, G&amp;A and Profit</i>	\$34,568
Installation Labor (Navy)	\$8,873
<b>Total Chock Insert Program Annual Cost</b>	<b>\$181,712</b>
<i>Annual Mooring Line Replacement Expense (Assuming 5 Year Life)</i>	\$1,392,000
<b>Total Mooring Line Program Cost</b>	<b>\$1,573,712</b>

This \$1,572,712 annual mooring line program rough order of magnitude cost represents a significant cost reduction compared to the current \$4,640,000 annual cost of mooring line replacement (material only).

### 8.3 Attachment Method

The initial chock insert design included in our proposal (shown in Figure 8-1) was to be attached to the chock using a series of set screw fasteners. The fasteners would be inserted into each chock insert piece and securely tightened into the chock. This would ensure quick and easy installation and make sure that the chock insert pieces remain stationary during operation.

**Figure 8-1: Initial Two Piece Chock Insert Design**

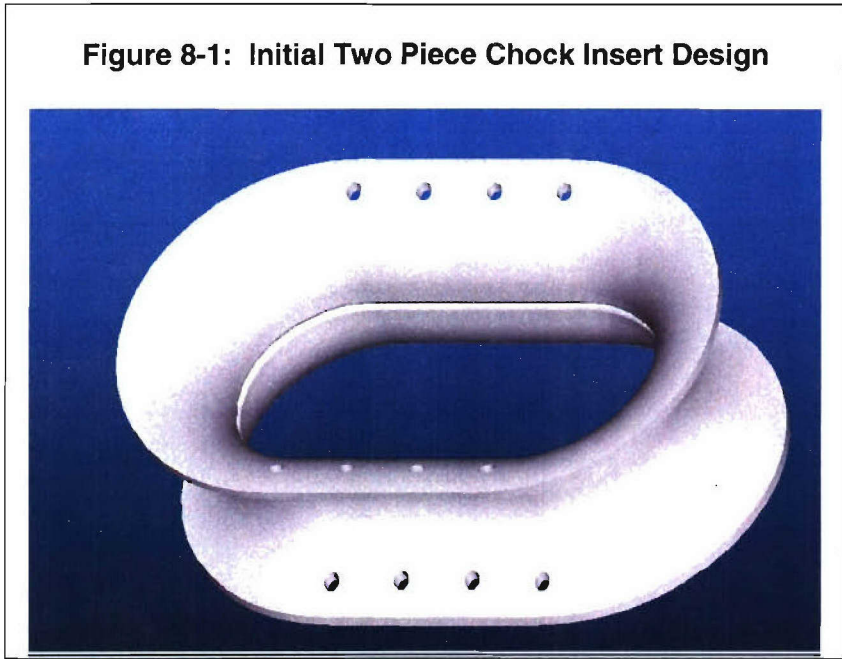

However, it was determined during the August 2, 2006 Technical Point of Contact (TPOC) meeting that no chock alterations are permitted. Chock alterations include drilling holes and/or impacting eye bolts or cleats that often exist around chock edges. Figure 8-2 contains examples of various chock configurations.

**Figure 8-2: Various Chock Configurations**

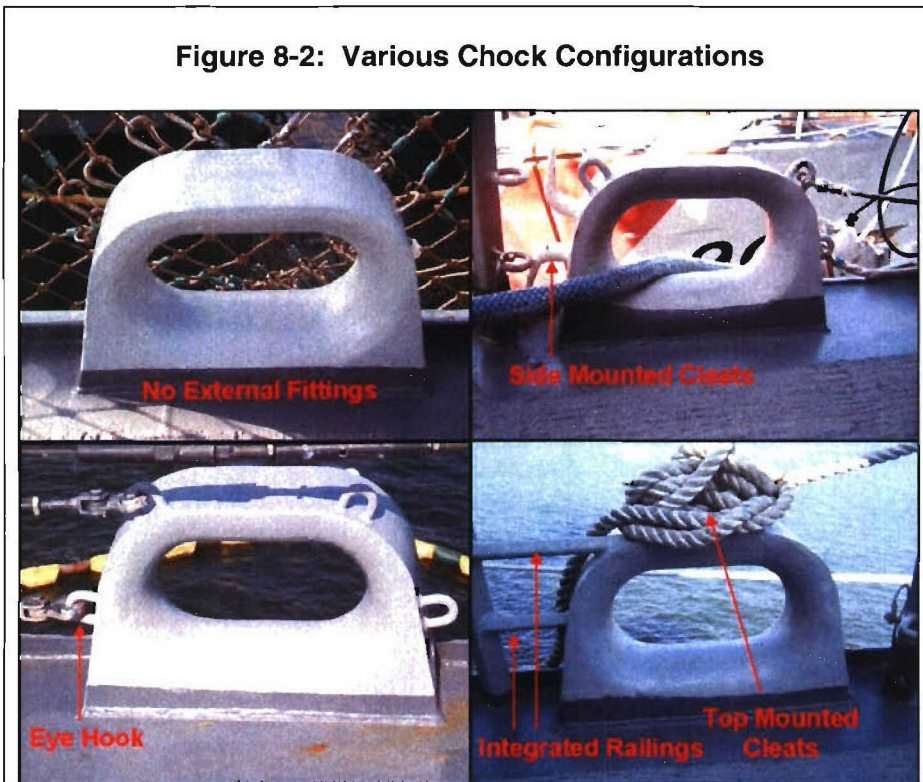

The data on this page are protected according to the data rights language provided on the title page of this document and can not be modified, reproduced, released or disclosed unless in accordance with terms on the cover page.

Thus, the original attachment method was abandoned and new methods were developed. Three acceptable attachment method options were developed.

### 8.3.1 Pin Insert Method

The pin insert method uses a series of blocks and holes that align so a locking pin can be inserted, similar to a door hinge. The pin, once in place, effectively holds each piece in a static position. The blocks are located underneath a solid shelf portion of the insert to keep the mooring line contact surface free of voids. A conceptual drawing of this design is provided in Figures 8-3 and 8-4. Figure 8-4 shows only one piece to clearly display the block/hole arrangement.

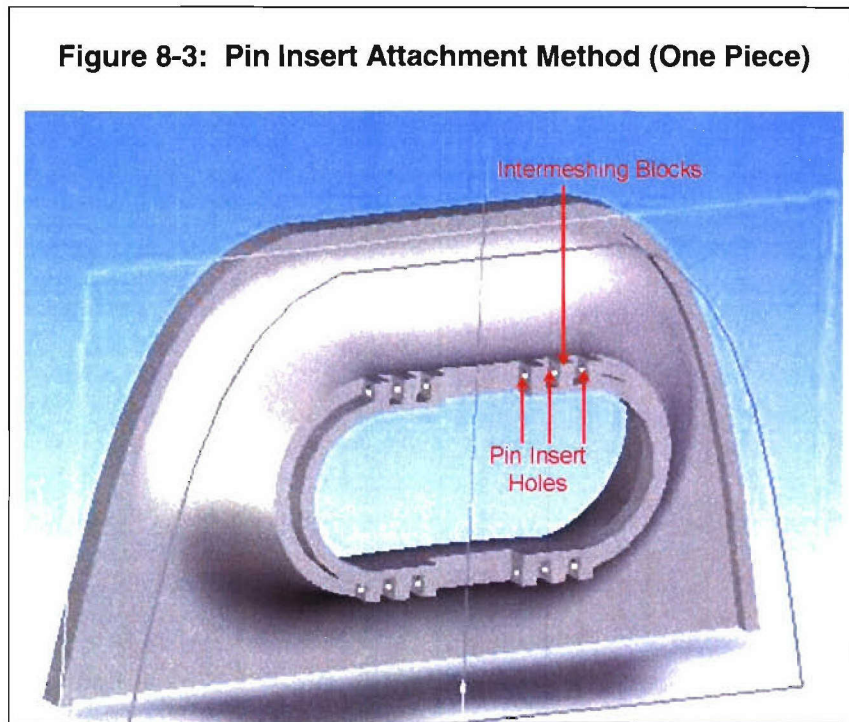
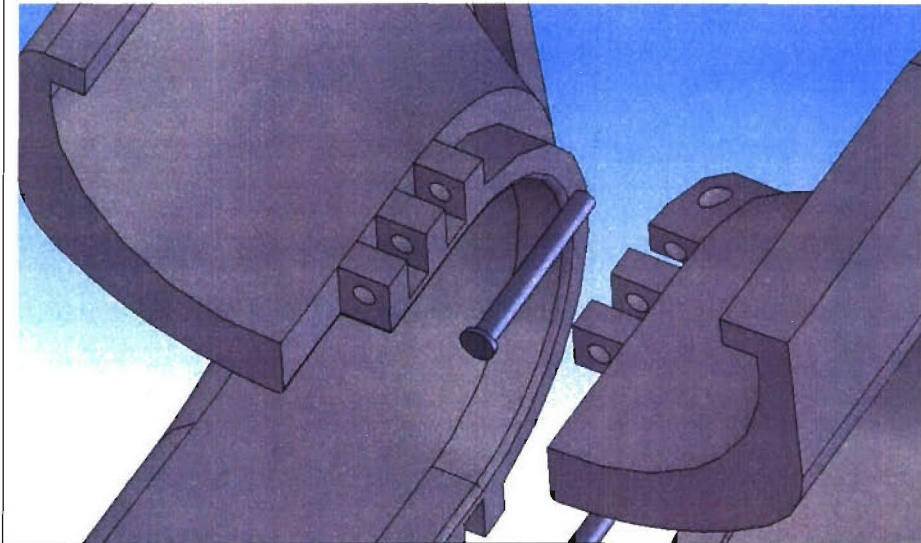

Figure 8-4 shows an exploded view that depicts how both pieces align so that the pin can be inserted.

**Figure 8-4: Pin Insert Attachment Method (Exploded View)**



### 8.3.2 Band Clamp Method

A simpler way of securing the insert pieces while satisfying the Navy's requirements is to install a series of band clamps. Figure 8-5 provides a drawing of this installation method. The clamps can be positioned so that they do not hinder the mooring line or interfere with chock eye bolts or cleats in any chock configuration.

**Figure 8-5: Band Clamp Attachment Method**

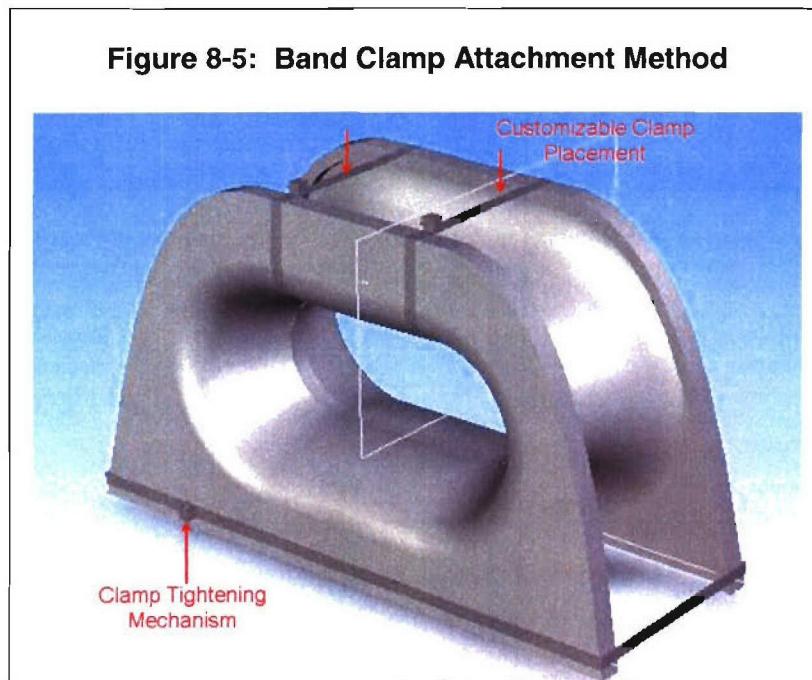

The data on this page are protected according to the data rights language provided on the title page of this document and can not be modified, reproduced, released or disclosed unless in accordance with terms on the cover page.

### 8.3.3 Snap Method

Another simple attachment method is a snap/lock feature that holds the insert pieces in place once they are pressed together. This method requires the fewest assembly steps and no auxiliary parts. Each insert piece has strategically located tabs that lock together once the pieces are put in place. Figure 8-6 provides a conceptual drawing of this installation method. The tabs can be placed in key locations around the chock opening and will not hinder the mooring line. Analysis and testing would be required to determine the method's structural feasibility and the proper tab placement.

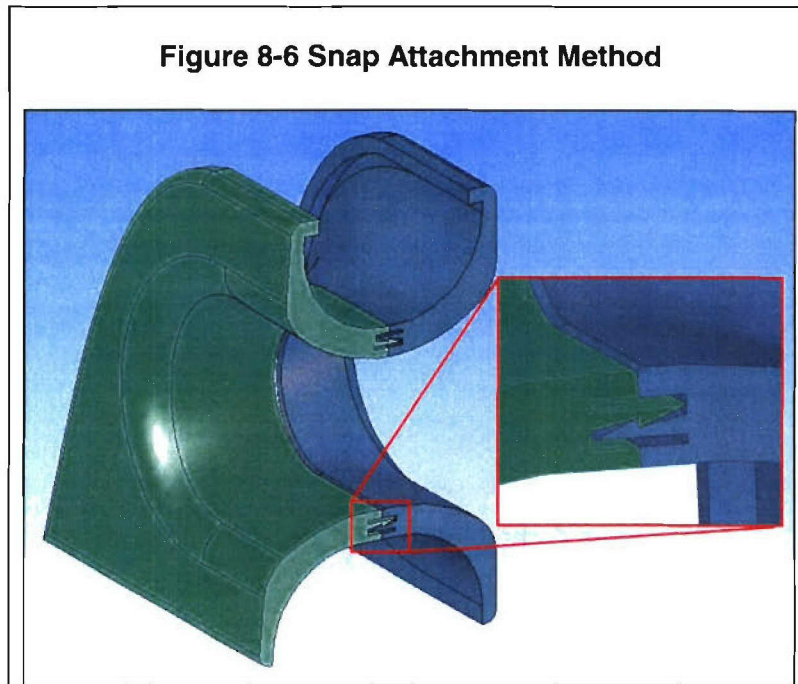

### 8.3.4 Final Attachment Method

The final attachment method selected during this Phase I project is the pin insert method. This attachment method appears to exhibit the best combination of secure holding strength and installation simplicity. The chock insert pieces must align in such a way that the mooring line does not contact any abrasive edges. The final insert design has rounded edges near the attachment seam. This smoothly curved recessed seam will keep the mooring line from encountering any discontinuities or sharp edges that would potentially accelerate mooring line wear. Further attachment method investigation and optimization are proposed for a Phase II study.

## 9.0 Prototype

A full scale Nylatron® NSM chock insert prototype is currently being manufactured by Quadrant Engineering Co. The prototype will be complete and delivered to the US Navy by December 20, 2006. This prototype utilizes the Pin Insert Method detailed in Section 8-3. The prototype will confirm the insert's constructability and allow the insert to be fitted into an actual Destroyer ship chock. The prototype design drawings are included in Appendix B.

## 10.0 Conclusions and Recommendations

Research, material testing and evaluation performed during Phase I have determined the following:

- Nylatron® NSM does not chemically alter or break down when exposed to a simulated marine environment or prolonged UV exposure.
- Nylatron® NSM is chemically inert and will not negatively impact the environment.
- Nylatron® NSM will maintain an exceptionally smooth surface and creates minute particulate material when abraded.
- Nylatron® NSM performs elastically under operational conditions and plastically deforms under mooring line safety factor loading conditions without cracking.
- Nylatron® NSM stock material color conforms to Navy ship color scheme.
- The insert design allows ample space for multiple mooring lines to pass through without protruding from the ships profile. This design attaches the insert to the chock without altering the chock itself.
- A Nylatron® NSM chock insert provides significant cost savings in comparison to current mooring line replacement expense.
- The Nylatron® NSM prototype demonstrates that the chock insert can be manufactured economically.

Based on the success of Phase I testing, additional laboratory and full scale prototype testing of Nylatron® NSM chock inserts is recommended for completion in a Phase II SBIR project.

## 11.0 Phase II Potential

Phase I testing and analysis determined that Nylatron® NSM meets the Navy's basic requirements for a chock insert material. Prototype development proved cost effective manufacture is possible. Additional Phase II material testing will provide the necessary data to optimize the current insert design. This includes:

- Performing additional abrasion testing combined with mooring line inspection. This would identify any mooring line damage initiation, which was not investigated in Phase I.
- Performing wear testing while test samples are subjected to higher pressures to simulate cases of simultaneous extreme loading and abrasion.
- Performing salt spray corrosion simulation to more accurately simulate ocean spray conditions.
- Performing cyclic salt spray wetting and UV drying to more accurately simulate typical in-port and underway conditions.
- Researching the cause of weight gain after vacuum drying in the simulated sea water condition corrosion tests.
- Performing Scanning Electron Microscopy or high level optical microscopy on the rope sections used in the Pin on Disk abrasion testing to determine if any particles are fouling the line, since no particulate matter could be collected during Pin on Disk testing.
- Performing post-water absorption Nylatron® NSM material strength testing. Because Nylatron® NSM will absorb water in a marine environment, its strength under these conditions should be verified.
- Performing Nylatron® NSM extended and/or accelerated UV exposure analysis. This would ensure that negative effects from a longer exposure time than Phase I allowed do not occur.

Phase II chock insert analysis and testing will include:

- Conducting a more extensive FEA to determine stress concentrations within the insert attachment points.
- Conducting full scale chock insert prototype testing to verify strength and failure mechanisms.
- Conducting full scale chock insert prototype testing to optimize the current attachment method.

Other Phase II tasks would include demonstration of installation, maintenance and removal methodologies and further development of chock insert life cycle costs and a complete cost-benefit analysis. A testing and validation plan would be developed to allow testing onboard a Navy ship, if agreed to by the Navy for Phase II.

The data on this page are protected according to the data rights language provided on the title page of this document and can not be modified, reproduced, released or disclosed unless in accordance with terms on the cover page.

As part of Phase II, Nelson Engineering Co. could also expand the project scope to include other surfaces that have been identified to cause mooring line damage. These components, seen in Figure 10-1, include capstans and dock tie-down points.

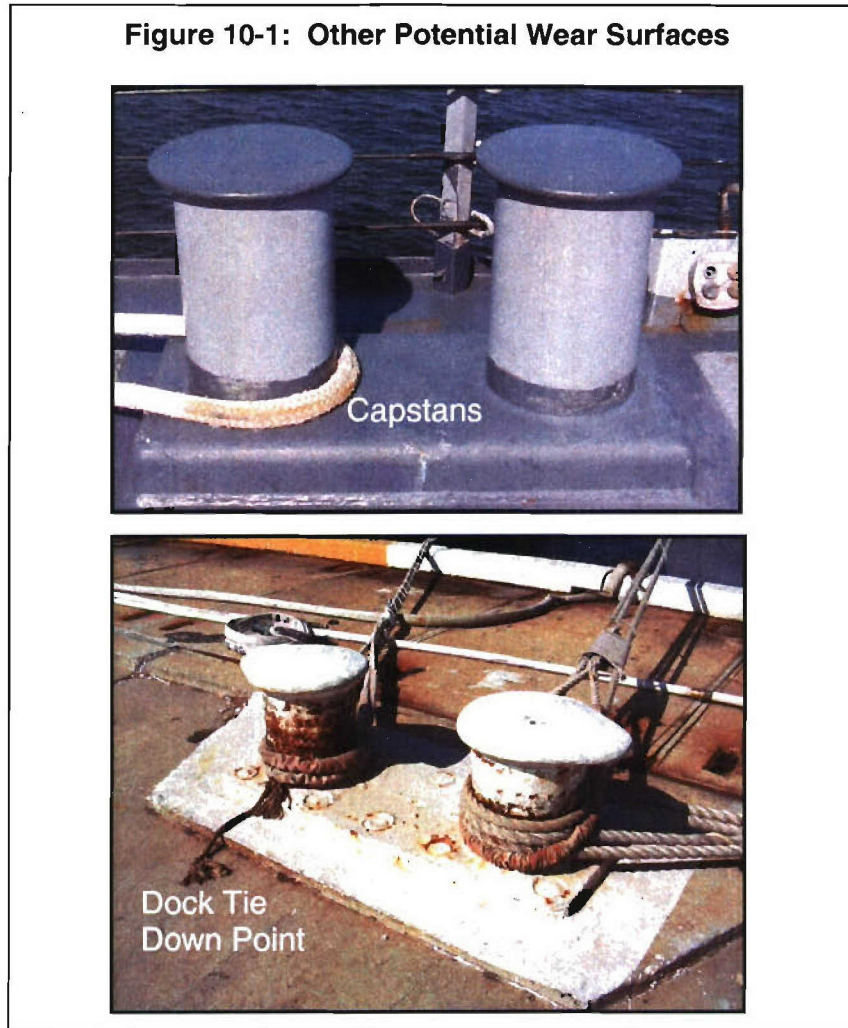

Nelson Engineering has developed a working relationship with Quadrant Engineering Co. during this Phase I project. Quadrant is the sole manufacturer of Nylatron® NSM and sees the potential for this application in both military and commercial use. Quadrant Engineering Co. has material testing and manufacturing expertise that will aid in a Phase II project and they will provide considerable insight into making the Nylatron® NSM insert more cost competitive.

## 12.0 Phase III Transition Plan

As required in Contract Data Requirements List Data Item A002, Nelson Engineering (NE) has developed a preliminary Phase III Transition Plan. Phase II will conclude with successfully testing chock inserts on-board a Navy vessel. The attachment method and all dimensions will be established. A patent application for the use of Nylatron ® NSM in a chock insert application and the attachment method will be prepared.

Phase III will include expansion of the chock insert to other Navy vessels, commercial market expansion, patent application and development of the supply chain/business management production, marketing and distribution system. NE will manage manufacturing, storage, marketing, customer support and business planning. Research will include business decisions such as patenting strategy, pricing strategy and market analysis. NE's reputation and relationship with DoD contractors and location near major ports will be useful in making contacts. Additional marketing will be done through the NE website and through direct marketing. Use of distributors will be considered for commercial marketing.

Manufacturing will be outsourced. Our location at the eastern entrance to the Central Florida High Technology Corridor affords us many options for manufacturing outsourcing and final product storage. Additional funding for manufacturing and entry into the commercial market will likely come from small business loans. This will be researched and completed near the middle of Phase III. These may be supplemented with funding from potential teammates such as Quadrant Engineering Inc. and Piedmont Plastics, Inc.

**Appendix A: Nylatron® NSM MSDS**

**MATERIAL SAFETY DATA SHEET**

**MSDS# 0700**

**SECTION 1**

QUADRANT EPP  
2120 FAIRMONT AVENUE  
P.O. BOX 14235  
READING, PA. 19612-4235

TELEPHONE NUMBERS:  
PRODUCT INFORMATION(Quadrant EPP ) -  
610-320-6600  
TRANSPORTATION EMERGENCY (CHEMTREC) -  
800-424-9300

MATERIAL IDENTIFICATION

PRODUCT NAME: **NYLATRON NSM**

CHEMICAL NAME: **EPSILON - CAPROLACTAM, CAST NYLON 6 - PLUS  
SOLID LUBRICANTS.**

CAS NO.: **25038-54-4 (BASE POLYMER)**

PRODUCT USE: **CUSTOM CASTING AND ENGINEERING THERMOPLASTIC  
STOCK SHAPE FOR SUBSEQUENT FABRICATION.**

TSCA INVENTORY STATUS: **ALL REPORTABLE INGREDIENTS ARE LISTED  
IN THE TSCA CHEMICAL SUBSTANCE INVENTORY.**

---

SECTION 2

HAZARDOUS INGREDIENTS (THIS IS A POLYMERIC MATERIAL. ALL  
CONSTITUENTS ARE ENCAPSULATED WITHIN THE POLYMER SYSTEM AND  
THEREFORE PRESENT NO LIKELIHOOD OF EXPOSURE UNDER NORMAL  
CONDITIONS OF PROCESSING AND HANDLING)

---

SECTION 3

HEALTH HAZARD DATA

ACUTE OR IMMEDIATE EFFECTS: ROUTES OF ENTRY AND SYSTEMS

INGESTION: **NOT A PROBABLE ROUTE OF EXPOSURE.**  
SKIN: **MOLTEN NYLON CAUSES THERMAL BURNS.**  
EYE: **MECHANICAL IRRITATION ONLY.**  
INHALATION: **SHAPES NOT RESPIRABLE.**

---

The data on this page are protected according to the data rights language provided on the title page of this document and can not be modified, reproduced, released or disclosed unless in accordance with terms on the cover page.

## SECTION 4

### EMERGENCY FIRST AID

- If exposed to fumes from overheating, move to fresh air. Consult a physician if symptoms persist.
- Wash skin with soap and plenty of water.
- Flush eyes with water. Consult a physician if symptoms persist.
- If molten polymer contacts skin, cool rapidly with cold water. Do not attempt to peel polymer from skin. Obtain medical attention to thermal burn.

CHRONIC EFFECTS: **NONE KNOWN.**

MEDICAL CONDITIONS GENERALLY AGGRAVATED BY THIS MATERIAL:  
**NONE KNOWN.**

---

## SECTION 5

### FIRE AND EXPLOSION HAZARD DATA

FLASH IGNITION TEMPERATURE: **752°F./400°C.** METHOD: **ASTM D-1929**

UNUSUAL FIRE, EXPLOSION HAZARDS: **NONE KNOWN.**

HAZARDOUS DECOMPOSITION PRODUCTS: **AT TEMPERATURES ABOVE 572°F./ 300°C., CARBON MONOXIDE, HYDROGEN CYANIDE AND NITROGEN GASSES WILL OCCUR.**

SPECIAL FIRE FIGHTING INSTRUCTIONS: **FIRE FIGHTERS AND OTHERS EXPOSED TO PRODUCTS OF COMBUSTION SHOULD WEAR FULL PROTECTIVE CLOTHING INCLUDING SELF-CONYAINED BREATHING APPARATUS. FIRE FIGHTING EQUIPMENT SHOULD BE THOROUGHLY DECONTAMINATED AFTER USE.**

EXTINGUISHING MEDIA: **WATER SPRAY OR ANY CLASS A EXTINGUISHING AGENT.**

---

## SECTION 6

### ACCIDENTAL RELEASES

The data on this page are protected according to the data rights language provided on the title page of this document and can not be modified, reproduced, released or disclosed unless in accordance with terms on the cover page.



**SPILL OR RELEASE: CLEAN UP BY VACUUMING OR WET SWEEPING TO PREVENT FALLS.**

---

SECTION 7

STORAGE CONDITIONS

**DRY STORAGE.**

---

SECTION 8

PROTECTION INFORMATION

**EYE: Safety glasses are recommended to prevent particulate matter from entering eyes while grinding or machining.**

**SKIN: Protective gloves are required when handling hot polymer. Also, long sleeve cotton shirt and long pants if handling molten polymer.**

**VENTILATION: Local exhaust at processing equipment to keep particulates below 15 mg/m<sup>3</sup>, the OSHA limit for nuisance dusts.**

**RESPIRATOR: None under normal processing, if ventilation is adequate.**

---

SECTION 9

PHYSICAL/CHEMICAL DATA

**APPEARANCE: STOCK SHAPE MAY BE ROD, PLATE, OR BUSHING.**

**ODOR: ESSENTIALLY ODORLESS.**

**MELTING POINT: 212-230°C./ 413-446°F.**

**SOLUBILITY IN WATER: INSOLUBLE**

**VOLATILE CONTENT %: <1%**

**SPECIFIC GRAVITY: 1.15**

---

SECTION 10

HAZARDOUS REACTIVITY

The data on this page are protected according to the data rights language provided on the title page of this document and can not be modified, reproduced, released or disclosed unless in accordance with terms on the cover page.



STABILITY AT ROOM TEMPERATURE: **STABLE.**

MATERIALS TO AVOID: **STRONG ACIDS AND OXIDIZING AGENTS.**

CONDITIONS TO AVOID: **HEATING ABOVE 300°C./ 572°F.**

---

## SECTION 11

### TOXICOLOGICAL INFORMATION

CHRONIC TOXICITY: **NYLATRON NSM DOES NOT APPEAR TO POSSESS ANY TOXICOLOGICAL PROPERTIES.**

MEDICAL CONDITIONS PRONE TO AGGRAVATION BY EXPOSURE: **THERMAL DECOMPOSITION PRODUCTS OF NYLON HAVE BEEN REPORTED TO BE IRRITATING TO THE MUCUS MEMBRANES AND RESPIRATORY TRACT.**

CARCINOGENICITY: **NONE KNOWN.**

---

## SECTION 12

### ECOLOGICAL INFORMATION

**AQUATIC TOXICITY: Toxicity is expected to be low based on insolubility of polymer in water.**

---

## SECTION 13

### DISPOSAL

**SPILL OR RELEASE: Clean up by vacuuming or wet sweeping to minimize dust exposure.**

**WASTE DISPOSAL: Recycling is encouraged, Landfill or incineration in compliance with Federal, State, and Local regulations.**

---

## SECTION 14

### TRANSPORT INFORMATION

DOT HAZARD CLASS: **NA**

SHIPPING NAME: **NA**

---

## SECTION 15

The data on this page are protected according to the data rights language provided on the title page of this document and can not be modified, reproduced, released or disclosed unless in accordance with terms on the cover page.

## REGULATORY INFORMATION

### SECTION 313 SUPPLIER NOTIFICATION:

(SARA TITLE III-TOXIC CHEMICALS LIST)

This product contains no known toxic chemicals subject to the reporting requirements of section 313 of the Emergency Planning and Community Right-To-Know Act of 1986 and 40 CFR 372.

### STATE RIGHT TO KNOW LAWS:

No substances on the state hazardous list, for the states I indicated below, are used in the manufacture of products on this Material Safety Data Sheet, with the exceptions indicated. While we do not specifically analyze these products, or the raw materials used in their manufacture, for substances on various state hazardous substances lists, to the best of our knowledge the products on this Material Safety Data Sheet contain no such substances except for those specifically listed below:

### PENNSYLVANIA:

SUBSTANCES ON THE PENNSYLVANIA HAZARDOUS SUBSTANCES LIST PRESENT AT A CONCENTRATION OF 1% OR MORE: **NONE KNOWN.**

SUBSTANCES ON THE PENNSYLVANIA SPECIAL HAZARDOUS SUBSTANCES LIST PRESENT AT A CONCENTRATION OF 0.01% OR MORE: **NONE KNOWN.**

### CALIFORNIA PROPOSITION 65:

SUBSTANCES KNOWN TO THE STATE OF CALIFORNIA TO CAUSE CANCER: **NONE KNOWN.**

SUBSTANCES KNOWN TO THE STATE OF CALIFORNIA TO CAUSE BIRTH DEFECTS OR OTHER REPRODUCTIVE HARM: **NONE KNOWN.**

---

### HMIS RATING

Health	0
Flammability	1

The data on this page are protected according to the data rights language provided on the title page of this document and can not be modified, reproduced, released or disclosed unless in accordance with terms on the cover page.



Reactivity	0
PPE	A
#Acute *Chronic	

SECTION 16

MISCELLANEOUS INFORMATION

Dennis Warner, QESH Manager

Reviewed July 5, 2006

Issued: May 30, 2003 Rev B

Supersedes: SEPTEMBER 17, 1996 Rev. A

The information set forth herein has been gathered from standard reference materials and/or supplier test data and is, to the best knowledge and belief of Quadrant EPP, accurate and reliable. Such information is offered solely for your consideration, investigation and verification, and it is not suggested or guaranteed that the hazard precautions or procedures mentioned are the only ones that exist. Quadrant EPP makes no warranties, expressed or implied, with respect to the use of such information or the use of the specific material identified herein in combination with any other material or process, and assumes no responsibility therefore.

NA = Not applicable NE = Not established.

> = New or revised information in this section when " > " appears in the left margin.

**END OF MSDS**

## Appendix B: Chock Insert Prototype Design Drawings

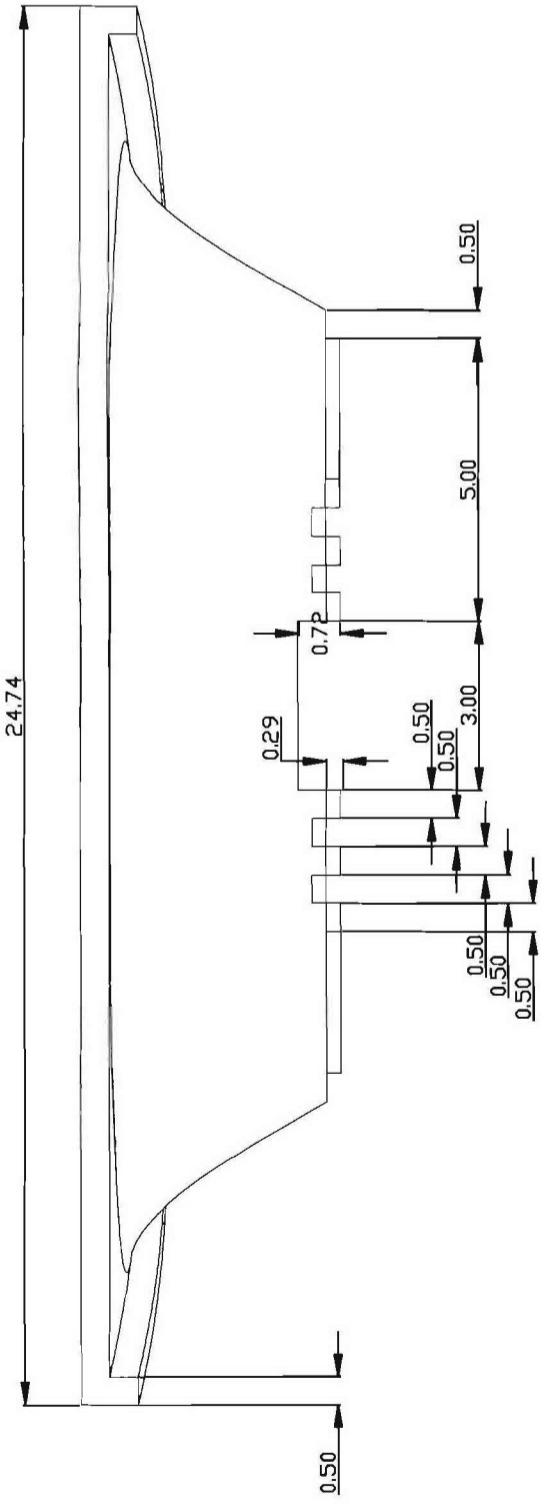

PIN INSERT 1  
FRONT VIEW

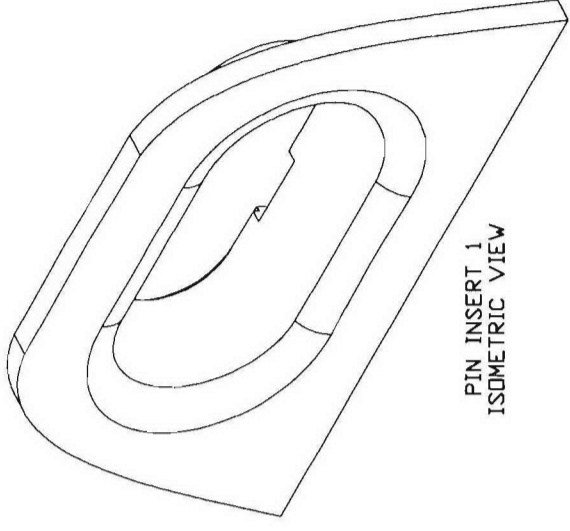

PIN INSERT 1  
ISOMETRIC VIEW

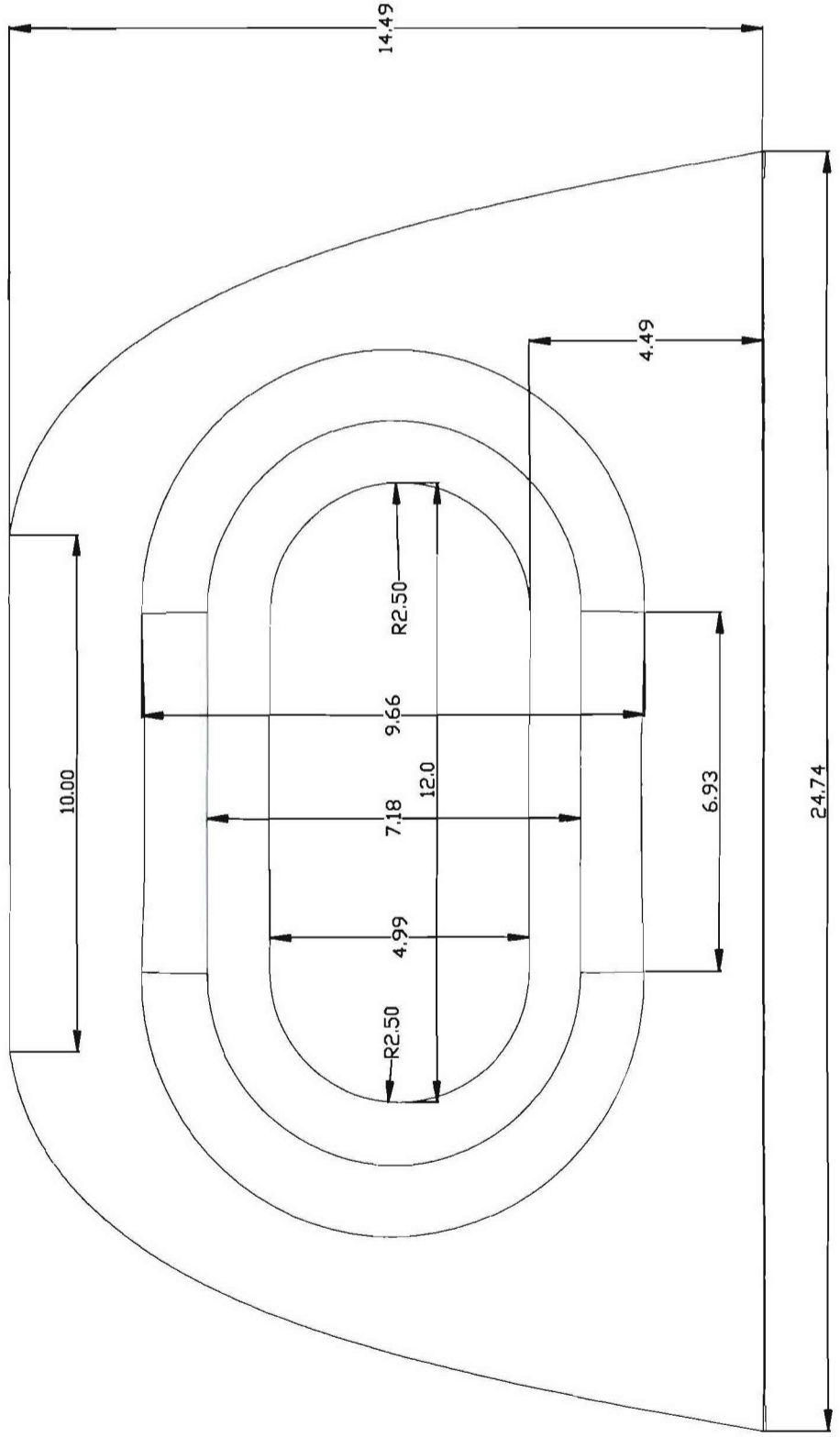

PIN INSERT 1  
BOTTOM VIEW

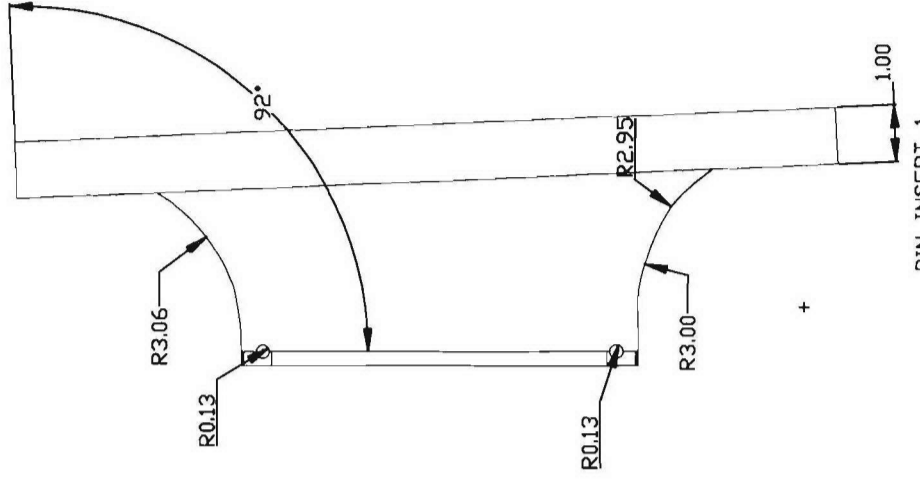

PIN INSERT 1  
SIDE VIEW