

AFRL-SN-WP-TP-2006-114

**INTERFERENCE CANCELLATION
USING POWER MINIMIZATION AND
SELF-COHERENCE PROPERTIES OF
GPS SIGNALS (PREPRINT)**



**Y.T. Jade Morton, Liyeh L. Liou, David M. Lin, James B.Y. Tsui,
and Qihou Zhou**

SEPTEMBER 2004

Approved for public release; distribution is unlimited.

STINFO COPY

This work has been submitted for publication in the 2004 Proceedings of Institute of Navigation Global Positioning System (ION GPS 2004). One or more of the authors is a U.S. Government employee working within the scope of their Government job; therefore, the U.S. Government is joint owner of the work. If published, the publisher may assert copyright. The Government has the right to copy, distribute, and use the work. All other rights are reserved by the copyright owner.

**SENSORS DIRECTORATE
AIR FORCE RESEARCH LABORATORY
AIR FORCE MATERIEL COMMAND
WRIGHT-PATTERSON AIR FORCE BASE, OH 45433-7320**

NOTICE

Using Government drawings, specifications, or other data included in this document for any purpose other than Government procurement does not in any way obligate the U.S. Government. The fact that the Government formulated or supplied the drawings, specifications, or other data does not license the holder or any other person or corporation; or convey any rights or permission to manufacture, use, or sell any patented invention that may relate to them.

This report was cleared for public release by the Air Force Research Laboratory Wright Site (AFRL/WS) Public Affairs Office (PAO) and is releasable to the National Technical Information Service (NTIS). It will be available to the general public, including foreign nationals.

PAO Case Number: AFRL/WS 04-0784, 10 Sep 2004.

THIS TECHNICAL REPORT IS APPROVED FOR PUBLICATION.

//Signature//

David M. Lin, Electronic Engineer
Reference Sensors and Receiver
Applications Branch
RF Sensors Technology Division
Sensors Directorate

//Signature//

Boyd E. Holsapple, Chief
Reference Sensors and Receiver
Applications Branch
RF Sensors Technology Division
Sensors Directorate

//Signature//

William E. Moore, Chief
RF Sensors Technology Division
Sensors Directorate

This report is published in the interest of scientific and technical information exchange and its publication does not constitute the Government's approval or disapproval of its ideas or findings.

REPORT DOCUMENTATION PAGE

Form Approved
OMB No. 0704-0188

The public reporting burden for this collection of information is estimated to average 1 hour per response, including the time for reviewing instructions, searching existing data sources, gathering and maintaining the data needed, and completing and reviewing the collection of information. Send comments regarding this burden estimate or any other aspect of this collection of information, including suggestions for reducing this burden, to Department of Defense, Washington Headquarters Services, Directorate for Information Operations and Reports (0704-0188), 1215 Jefferson Davis Highway, Suite 1204, Arlington, VA 22202-4302. Respondents should be aware that notwithstanding any other provision of law, no person shall be subject to any penalty for failing to comply with a collection of information if it does not display a currently valid OMB control number. **PLEASE DO NOT RETURN YOUR FORM TO THE ABOVE ADDRESS.**

1. REPORT DATE (DD-MM-YY) September 2004		2. REPORT TYPE Conference Paper Preprint		3. DATES COVERED (From - To) 11/01/2002 – 09/01/2004	
4. TITLE AND SUBTITLE INTERFERENCE CANCELLATION USING POWER MINIMIZATION AND SELF-COHERENCE PROPERTIES OF GPS SIGNALS (PREPRINT)				5a. CONTRACT NUMBER In-house	
				5b. GRANT NUMBER	
				5c. PROGRAM ELEMENT NUMBER 62204F	
6. AUTHOR(S) Y.T. Jade Morton and Qihou Zhou (Miami University, Oxford, OH) Liyeh L. Liou, David M. Lin, and James B.Y. Tsui, (AFRL/SNRP)				5d. PROJECT NUMBER 7622	
				5e. TASK NUMBER 11	
				5f. WORK UNIT NUMBER 08	
7. PERFORMING ORGANIZATION NAME(S) AND ADDRESS(ES) Reference Sensors and Receiver Applications Branch (AFRL/SNRP) Miami University, Oxford, OH RF Sensors Technology Division Sensors Directorate Air Force Research Laboratory, Air Force Materiel Command Wright-Patterson AFB, OH 45433-7320				8. PERFORMING ORGANIZATION REPORT NUMBER AFRL-SN-WP-TP-2006-114	
9. SPONSORING/MONITORING AGENCY NAME(S) AND ADDRESS(ES) Sensors Directorate Air Force Research Laboratory Air Force Materiel Command Wright-Patterson Air Force Base, OH 45433-7320				10. SPONSORING/MONITORING AGENCY ACRONYM(S) AFRL-SN-WP	
				11. SPONSORING/MONITORING AGENCY REPORT NUMBER(S) AFRL-SN-WP-TP-2006-114	
12. DISTRIBUTION/AVAILABILITY STATEMENT Approved for public release; distribution is unlimited.					
13. SUPPLEMENTARY NOTES PAO Case Number: AFRL/WS 04-0784, 10 Sep 2004. This paper contains color. This conference paper preprint work has been submitted for publication in the 2004 Proceedings of Institute of Navigation Global Positioning System (ION GPS 2004). One or more of the authors is a U.S. Government employee working within the scope of their Government job; therefore, the U.S. Government is joint owner of the work. If published, the publisher may assert copyright. The Government has the right to copy, distribute, and use the work. All other rights are reserved by the copyright owner.					
14. ABSTRACT This paper presents the performance analysis of two digital beam forming techniques used in conjunction with a software GPS receiver to mitigate interference to GPS signals in jamming environment. The first method is the constrained minimum power (MOP) method. The second method is the so-called self-coherence restoral (SCORE) method. Both experimental and simulation data are used in the study. The study was performed using experiment data collected in an anechoic chamber to obtain GPS and interference signals. A two by two GPS antenna array and a four channel radio frequency front end are used to collect simulated GPS data generated using hardware-based simulator in controlled jamming environment. Three types of interference signals are deployed in the experiments: FM chirp, binary phase shift key, and broadband. The interference power levels used were +20, +30, and +40 dB above GPS signal power. A software GPS receiver was used to perform acquisition of GPS signals to evaluate the performance of the beam forming algorithms. The preliminary result showed that MOP method can effectively mitigate all three types of interference at all power levels if a single jammer is present. Experiments using multiple broadband jammers were also analyzed and our results shown that the effectiveness of the MOP diminishes as the jammer power increases and ceases to function at the +40 dB level. The SCORE method does not exhibit consistent performance for the experimental data. This is consistent with our simulation results which show that for the SCORE algorithm to generate satisfactory results, sufficient number of antenna elements is necessary even if there is no interference source present. The number of antenna element is determined by the number of satellites available, as well as the number of interference source. Detailed analysis of the simulation and experimental results are discussed in this paper.					
15. SUBJECT TERMS Software GPS receiver, SCORE, MOP, jamming, in-house					
16. SECURITY CLASSIFICATION OF:			17. LIMITATION OF ABSTRACT: SAR	18. NUMBER OF PAGES 18	19a. NAME OF RESPONSIBLE PERSON (Monitor) David M. Lin
a. REPORT Unclassified	b. ABSTRACT Unclassified	c. THIS PAGE Unclassified			

Interference cancellation using power minimization and self-coherence properties of GPS signals

Y. T. Jade Morton, *Miami University*

Liyeh L. Liou, David M. Lin, James B. Y. Tsui, *Air Force Research Laboratories*

Qihou Zhou, *Miami University*

BIOGRAPHY

Dr. Jade Morton is an Assistant Professor in the Department of Electrical and Computer Engineering at Miami University. Her research interests are digital signal processing, software GPS receivers, and modeling of the ionosphere. She holds a BS in Physics from Nanjing University, China, a MS in Electrical Engineering from Case Western Reserve University, a MS in Systems Analysis from Miami University, and a PhD in Electrical Engineering from the Pennsylvania State University.

Dr. Liyhieh Liou received a BS in Physics, a MS in Geophysics, and a PhD in Physics from University of Southern California. He works for AFRL at WPAFB, OH. His interests are modeling of semiconductor devices, electromagnetic simulations and signal processing.

Dr. James Tsui is an Electronics Engineer at AFRL, WPAFB, OH. He received a BSEE from National Taiwan University, Taiwan, a MSEE from Marquette University, WI, and a PhD in Electrical Engineering from the University of Illinois at Urbana. His work is mainly involved with digital microwave receivers and GPS receivers.

Mr. David Lin is an Electronics Engineer at AFRL, WPAFB, OH. He received a BSEE from Tatung Institute of Technology, Taiwan, a MSEE and a MEME from Tennessee Technological University, and a MSCS from Wright State University. His work involves Electronic Warfare, Digital Signal Processing, and Radar and Electronic Countermeasure Simulation.

Dr. Qihou Zhou is an Assistant Professor in the Department of Electrical and Computer Engineering at Miami University. His research interests are in modeling and remote sensing of the ionosphere. He holds a BS from Harbin Technical University, China, a MS in Electrical Engineering, a MS in Mathematics, and a PhD in Electrical Engineering all from the Pennsylvania State University.

ABSTRACT

This paper presents the performance analysis of two digital beam forming techniques used in conjunction with a software GPS receiver to mitigate interference to GPS signals in jamming environment. The first method is the constrained minimum power (MOP) method. The second method is the so-called self-coherence restoral (SCORE) method. Both experimental and simulation data are used in the study.

The study was performed using experiment data collected in an anechoic chamber to obtain GPS and interference signals. A two by two GPS antenna array and a four channel radio frequency front end are used to collect simulated GPS data generated using hardware-based simulator in controlled jamming environment. Three types of interference signals are deployed in the experiments: FM chirp, binary phase shift key, and broadband. The interference power levels used were +20, +30, and +40 dB above GPS signal power. A software GPS receiver was used to perform acquisition of GPS signals to evaluate the performance of the beam forming algorithms. The preliminary result showed that MOP method can effectively mitigate all three types of interference at all power levels if a single jammer is present. Experiments using multiple broadband jammers were also analyzed and our results shown that the effectiveness of the MOP diminishes as the jammer power increases and ceases to function at the +40 dB level. The SCORE method does not exhibit consistent performance for the experimental data. This is consistent with our simulation results which show that for the SCORE algorithm to generate satisfactory results, sufficient number of antenna elements is necessary even if there is no interference source present. The number of antenna element is determined by the number of satellites available, as well as the number of interference source. Detailed analysis of the simulation and experimental results are discussed in this paper.

1. INTRODUCTION

A number of methods and approaches have been proposed and reported to mitigate interference for the GPS receivers in jamming environment. Most of these reports, however, are based on simulation results (Amin et al, 2003; Amin et al, to appear; Blazquez et al, 1999; Fante and Vacarro, 1998, 2000; Hatke, 1998; Moelker et al, 1996; Zhang et al, 2001; Zoltowski and Gecan, 1995). Recently, efforts are being made to investigate the experimental performance of the various beamforming techniques (Liou et al., 2001; McDonald et al, 2004). In this study, two beamforming techniques, the constrained minimum power (MOP) method and self-coherence restoral (SCORE) method, were implemented to evaluate their claimed performance using experimental data collected in controlled jamming environment. Simulation studies were also performed to validate the algorithms. A software GPS receiver is used to perform GPS signal acquisition of the beam former output.

The MOP method utilizes the fact that GPS signals are far beneath the thermal noise level. Minimization of total GPS receiver input power while maintaining gains along the directions of GPS satellites will suppress the interference contribution. The SCORE method is based on known repetitive nature of the GPS signal CA code. GPS signal samples separated by integer multiples of the CA code length while within the same navigation data bit are self-coherent because of the code repetition property. Both methods have claimed pros and cons in the literature. MOP method may work effectively on a variety of jamming sources. But it requires prior knowledge of the satellite orientation. The SCORE method does not need any satellite position information. It is, however, ineffective against jamming sources that have self-coherent prosperities. Moreover, our study showed that for the SCORE method, the number of antenna element is determined not only by the number of interference sources, but also by the number of satellites available.

Section 2 of the report will describe the experimental setup that generated the data for the study. Section 3 summarizes the MOP and SCORE methods implemented in the study. The simulation results and experimental data analysis will be presented in Section 3 and 4 respectively. Section 5 concludes the summer project and discusses future works.

2. EXPERIMENTAL SETUPS

GPS signals in controlled jamming environment were collected in an anechoic chamber. Figure 1 shows the setup of the experiment. A two by two conventional GPS L1/L2 patch antenna array was placed in a geodesic dome as shown. The antenna elements are marked with number

1 through 4 respectively. The distance d from an antenna element to the center of the dome is 7 cm. Phase calibration of the antenna elements has been performed and the results were used in the beam forming algorithm (Liou et al, 2002). The distance between the elements, the size of the antenna, and the size of the geodesic dome are not drawn to proportion.

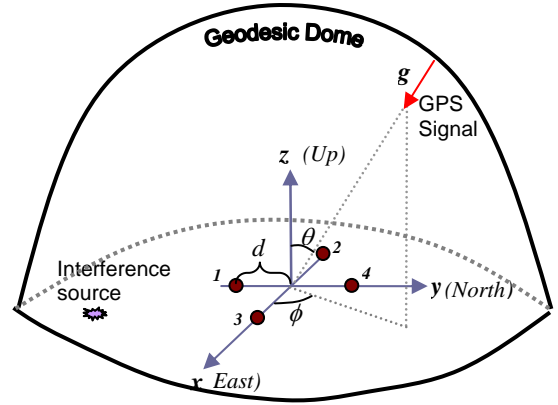

Fig. 1. Antenna elements layout and experimental setup.

Eight GPS antennas transmitted signals from a GPS simulator were mounted on the dome to mimic a GPS constellation. Three extra antennas were placed nearby to transmit interference signals. The interference signal has three modulation schemes: a bi-phase shift key (BPSK) source with 10k and 1M modulation rates, a frequency-modulated (FM) chirp source with 1k and 10k modulation rates, and a 35 MHz-bandwidth broadband random noise. The power levels were +20, +30 and +40 dB above the GPS signals in the L1 band. A sky plot of the GPS transmitters and the interference sources placements are shown in Figure 2. The interference sources are represented by J1, J2, and J3, while the numbers 4, 5, 6, 10, 13, 24, 26, and 30 represent the GPS transmitters, with the numbers representing GPS satellite ID. The azimuth angle ϕ is measured counter-clockwise from East (x axis) and spans 0 to 360 degrees. The rings in the plot represents inclination angles (θ) ranging from 0 (upward in the z axis direction) to 90 degrees (horizon).

A four-channel RF/IF front end is used to collect and digitize the outputs from each antenna element. Figure 3 shows the block diagram of a single channel of the RF/IF front end. The digitized outputs from each channel are stored for beam forming and software receiver processing.

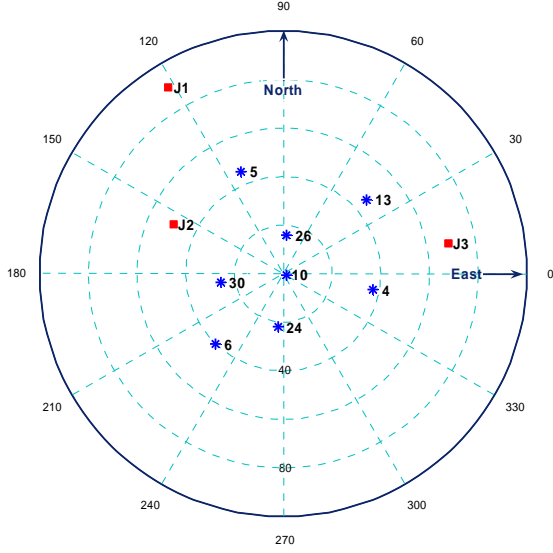

Fig. 2. Sky view of satellites and interference sources in the experimental setup

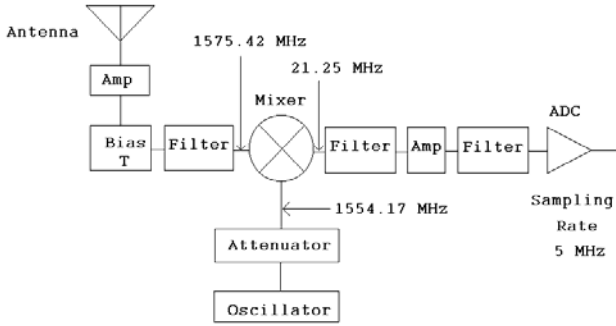

Fig. 3. Block diagram of a single channel GPS receiver RF/IF front end

3. BEAM FORMING ALGORITHMS

A simple spatial adaptive processor as shown in Figure 4 is used in this study. Inputs from the antenna elements (x_k , $k = 1, \dots, K$) are applied with weight (w_k , $k = 1, \dots, K$) and combined to generate an output y .

$$y = \sum_{k=1}^K w_k x_k = w^H x, \quad (1)$$

where,

$$w = [w_1 \ w_2 \ \dots \ w_K]^T, \quad x = [x_1 \ x_2 \ \dots \ x_K]^T.$$

Beam forming algorithms are designed to generate a set of optimized weight w , so that y is a much improved version of the input signal x in that the interference and jamming signals are suppressed, while the GPS signals are enhanced.

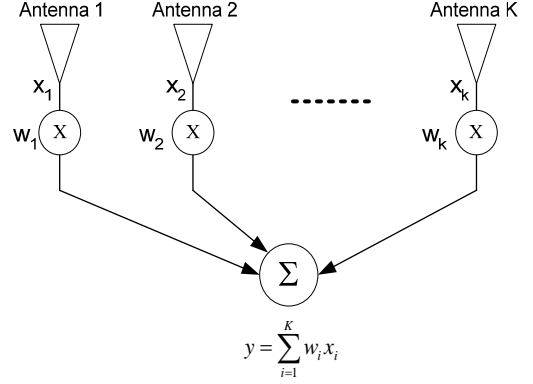

Fig. 4. Schematics of a K-element antenna array spatial adaptive processor

3.1. MULTI-ANTENNA ELEMENTS GPS RECEIVER INPUTS

The signal impinging on an antenna element is the collection of inputs from all GPS signals in direct view of the antenna, their multipath and interference, and noise:

$$x_k = \sum_{p=1}^P g_p a_{kp}(\theta_p, \phi_p) + \sum_{q=1}^Q v_q b_{kq}(\theta_q, \phi_q) + n_k \quad (2)$$

where,

P : Number of GPS signals received by the antenna.

Q : Number of interference (including multipath) signals received by the antenna.

θ_p, ϕ_p : The p^{th} GPS satellite inclination and azimuth angle.

a_{kp}, b_{kq} : The k^{th} antenna spatial phase delay factor for a signal arrival from a specified direction.

v_q : The q^{th} interference signal at the reference location.

θ_q, ϕ_q : The q^{th} interference source inclination and azimuth angle.

$n_k(t)$: Noise component for the k^{th} antenna.

$g_p(t)$: The p^{th} GPS satellite signal received at a reference location.

$$g_p = A_p e^{j(2\pi f_p t + \varphi_p)} \sum_{n=-\infty}^{\infty} h_p(n) u_p(t - nT_c) \quad (3)$$

In Equation (3), $f_p = f_{L1} + f_{Dp}$ is the GPS signal carrier frequency, f_{L1} is GPS satellite L1 band center frequency, f_{Dp} , A_p , φ_p , h_p , and $u_p(t - nT_c)$ are the satellite signal Doppler frequency, amplitude, carrier phase, navigation data, and CA code with chip duration T_c .

Equation (2) can be written in a more compact form:

$$x = as + bv + n \quad (4)$$

where,

$$s = [g_1 \ g_2 \ \dots \ g_P]^T, \quad v = [v_1 \ v_2 \ \dots \ v_Q]^T,$$

$$n = [n_1 \ n_2 \ \dots \ n_K]^T,$$

$$a = [\bar{a}_1 \ \bar{a}_2 \ \dots \ \bar{a}_P], \quad b = [\bar{b}_1 \ \bar{b}_2 \ \dots \ \bar{b}_Q].$$

\bar{a}_p ($p=1, \dots, P$) and \bar{b}_q ($q=1, \dots, Q$) are the spatial signatures (also called steering vector or directional

vector) of GPS signal source p and interference source q . Assuming all signals are from far field sources and that the time it takes for a signal to travel between array elements is much smaller than inverse of the receiver bandwidth, the spatial signature for a GPS satellite is:

$$\vec{a}_p = \begin{bmatrix} a_{1p} \\ a_{2p} \\ \vdots \\ a_{kp} \end{bmatrix} = \begin{bmatrix} e^{j2\pi f_p \tau_{1p}} \\ e^{j2\pi f_p \tau_{2p}} \\ \vdots \\ e^{j2\pi f_p \tau_{kp}} \end{bmatrix} \quad (5)$$

where, $\tau_{kp} = \hat{g}_p \cdot (\vec{r}_k - \vec{r}_0) / c$, \hat{g}_p is the unit vector pointing from the p^{th} signal source toward the k^{th} antenna, \vec{r}_k and \vec{r}_0 are position vectors of the k^{th} antenna and the reference location, respectively, and c is the speed of light. For the 4-element antenna shown in Figure 1, if antenna element 1 is the reference location, the steering vector associated with a particular signal source p is:

$$\vec{a}_p = \begin{bmatrix} 1 \\ e^{j2\pi f_p \sin \theta_p (\cos \phi_p - \sin \phi_p) d / c} \\ e^{-j2\pi f_p \sin \theta_p (\cos \phi_p + \sin \phi_p) d / c} \\ e^{-j4\pi f_p \sin \theta_p \sin \phi_p d / c} \end{bmatrix} \quad (6)$$

A 9-element antenna array is used in simulation studies. The 9-element antenna array assumed the layout as shown in Figure 5. The steering vector for this antenna array layout is:

$$\vec{a}_p = \begin{bmatrix} e^{-j2\pi f_p \sin \theta_p (\cos \phi_p - \sin \phi_p) d / c} \\ e^{-j2\pi f_p \sin \theta_p \cos \phi_p d / c} \\ e^{-j2\pi f_p \sin \theta_p (\cos \phi_p + \sin \phi_p) d / c} \\ e^{j2\pi f_p \sin \theta_p \sin \phi_p d / c} \\ 1 \\ e^{-j2\pi f_p \sin \theta_p \sin \phi_p d / c} \\ e^{j2\pi f_p \sin \theta_p (\cos \phi_p + \sin \phi_p) d / c} \\ e^{j2\pi f_p \sin \theta_p \cos \phi_p d / c} \\ e^{j2\pi f_p \sin \theta_p (\cos \phi_p - \sin \phi_p) d / c} \end{bmatrix} \quad (7)$$

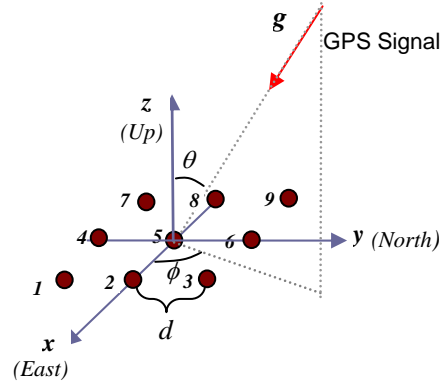

Fig. 5. Layout of a 9-element antenna array used in simulation study.

3.2. MOP METHOD

Assuming that GPS signals, interference, and noise are uncorrelated, the total combined average output signal power at the receiver is:

$$E\{|y(t)|^2\} = w^H R_x w = w^H (R_s + R_V + R_n) w \quad (8)$$

where, $R_x = E\{xx^H\}$, $R_s = E\{SS^H\}$, $R_V = E\{VV^H\}$, and $R_n = E\{nn^H\}$ are the expected correlation matrix for the total input signal, GPS signals, interference, and noise respectively. In the MOP method, the weight vector w is obtained by minimizing the total output power given by (8), while constrain the gain along the direction of known satellites:

$$\min_w w^H R_x w \quad \text{subject to } w^H a_p = 1 \quad (9)$$

The solution that satisfies (9) is (Godara, 2004):

$$w = R_x^{-1} a (a^H R_x^{-1} a)^{-1} \quad (10)$$

where a contains the spatial signature for those satellites whose directions are known and whose signals are of interests to the user. Zoltowski and Gecan (1995) pointed out that the constraints applied in the optimization process consume the limited number of degrees of freedom associated with a phased array. It may provide up to K-P spatial nulls to cancel interference. As can be seen from the analysis results to be presented in Section 5, this is truly the case for the array used in this study.

3.3. SCORE METHOD

The SCORE method was proposed by Agee et al (1990) and was applied to GPS interference cancellation by Sun and Aimin (to appear). The SCORE method explores the unique characteristics of a class of signals that are *spectrally self-coherent*, ie, the correlation between a signal $s(t)$ and its frequency-shifted version for some time lag is non-zero:

$$\rho_s^\beta(\tau) = \frac{\langle s(t)s^*(t-\tau)e^{-j2\pi\beta t} \rangle_\infty}{\sqrt{\langle |s(t)|^2 \rangle_\infty \langle |s^*(t-\tau)e^{-j2\pi\beta t}|^2 \rangle_\infty}} = \frac{R_s^\beta(\tau)}{R_s(0)} \neq 0 \quad (11)$$

where the notation $\langle \bullet \rangle_\infty$ represents infinite time averaging operation. The function $\rho_s^\beta(\tau)$ is referred to as the *spectral self-coherence function* of $s(t)$. $R_s^\beta(\tau)$ and $R_s(0)$ are the *cyclic autocorrelation function* and autocorrelation function of $s(t)$ respectively. The SCORE algorithms aims at obtaining optimized weight vector w that maximize the cyclic components of a receiver input. If the interference and noise at a GPS receiver are not spectrally self-coherent at frequency separation β , the cyclic autocorrelation of the receiver input x is:

$$R_x^\beta(\tau) = |a|^2 R_s^\beta(\tau) + |b|^2 R_n^\beta(\tau) + R_n^\beta(\tau) = |a|^2 R_s^\beta(\tau) \quad (12)$$

The CA code of GPS signals $u_p(t-nT_c)$ as shown in Equation (3) has a chip duration of $T_c = 977$ ns and the code period T is 1 ms. The GPS navigation data has a data rate of 50 Hz. As a result, the CA code repeats itself 20 times within one navigation data bit. Within the same navigation data bit, a GPS satellite signal is spectrally self-coherent without frequency separation. The collection of all GPS satellite signals at a receiver input is also spectrally self-coherent without frequency separation. Because of this property, Sun and Aimin (to appear) developed a self-coherent beam former. Two set of inputs are used in the processor: the direct input x from the antenna array, and a delayed version of the input $x(t-mT)$ where m is an integer. The direct input x is applied with a set of weight w to generate an output y , while the delayed input $x(t-mT)$ is applied with another set of weight w' to generate a reference output y' . The difference between y and y' , e , is minimized to generate optimized weight w' . This minimization is done in the least-square sense. The main beam former generates weight w by maximizing the correlation between y and y' :

$$F(w, w') = \frac{|R_{yy'}|^2}{R_y R_{y'}} \quad (13)$$

$$R_{yy'} = E\{yy'\} = w^H R_x(mT)w \quad (14)$$

$$R_y = E\{yy\} = w^H R_x(0)w \quad (15)$$

$$R_{y'} = E\{y'y'\} = w'^H R_x(0)w' \quad (16)$$

$R_x(mT)$ denotes the correlation of x with its mT delayed version and $R_x(0)$ is the auto-correlation function of x . Assuming that interference and noise are uncorrelated between themselves and their mT delayed version, then $R_x(mT) = R_x$. Maximizing $F(w, w')$ is therefore the maximization of total GPS signal output.

Substituting (14), (15), and (16) into (13) and solve for the optimization problem, the desirable weight vector w is the eigenvector corresponding to the largest eigenvalue of the generalized eigenvalue problem:

$$R_x w = \lambda_{\max} R_x(mT) R_x^{-1} R_x^H(mT) w \quad (17)$$

MatLab is used to implement both the MOP and the SCORE algorithm. The correlation matrix R_x and $R_x(mT)$

are calculated using multiple blocks of digitized GPS input data. This is necessary to reduce the impact of possible navigation data bits transition within an input data block or its delay version. Figure 6 explains the general idea of data block selection. Each block contains exactly one CA code period of data. If Data Block 2 which contains a navigation data bit transition is used to calculate the correlation functions, the self-coherence property of the signal will be non-existence or greatly reduced. Using the averaged correlation results of multiple blocks of data and their corresponding delayed blocks will lessen the impact of the navigation data bit transition.

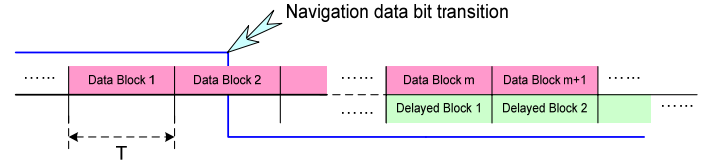

Fig. 6. Data Block Selection for SCORE Algorithm

4. SIMULATION RESULTS

Simulation inputs containing GPS signals and noise only are generated to test the beam forming algorithm performance in this project. Inputs from two different antenna arrays are simulated. Both MOP and SCORE are used to process the simulated inputs and will be discussed in the following two subsections.

4.1. MOP METHOD

Figure 7 shows two example antenna gain patterns generated for an input signal that contains all eight satellites shown in Figure 2 using the MOP method. A 4-element antenna is used in the simulation. A single beam constraint is applied in both cases. The figure shows that MOP is capable of generating a well defined beam towards the given satellite direction.

The performance of the MOP method degrades as the number of beam constraints increases. This is evident as shown in Figure 8 where 3-beam constraints and 8-beam constraints are applied for the 4-element antenna input.

The number of antenna elements increases the degree of freedom of the MOP beam former. Figure 9 is generated using the same input as that of Figure 8 and applied to a 9-element planar-layout antenna array. Comparison of Figure 9 with Figure 8 shows clearly the improvement of the beam forming algorithm performance due to the increase in the number of antennas.

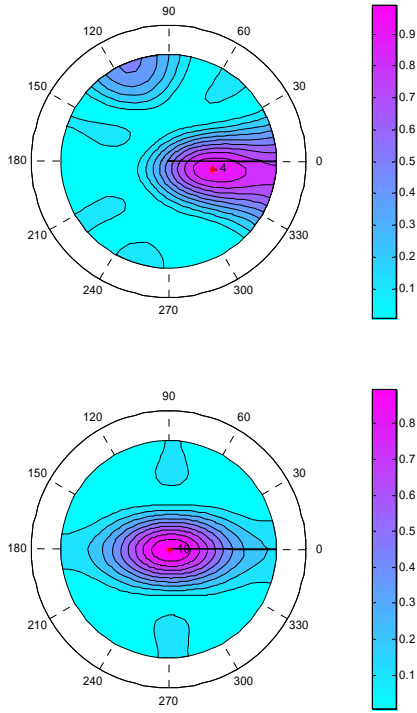

Fig. 7. Simulated antenna gain pattern using 4-element antenna and MOP algorithm for single satellite, no jammer scenarios.

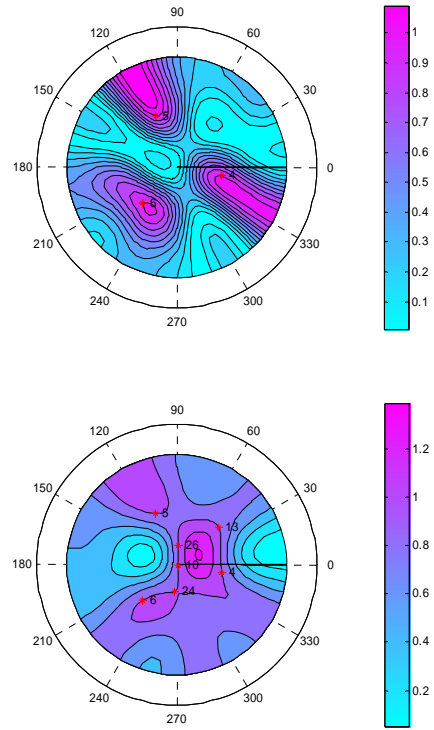

Fig. 9. Simulated antenna gain pattern using 9-element antenna and MOP algorithm for multiple satellites, no jammer scenarios.

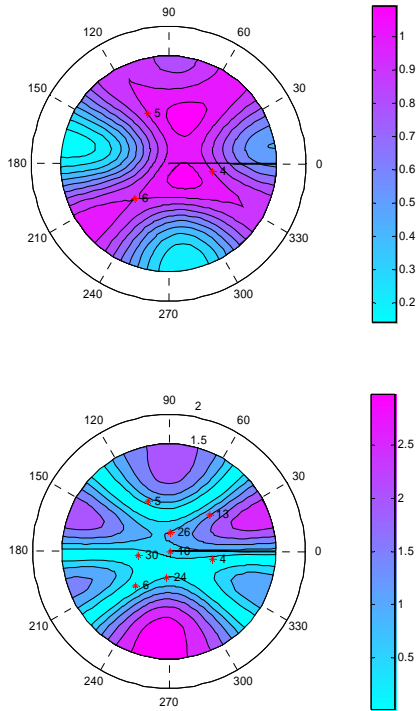

Fig. 8. Simulated antenna gain pattern using 4-element antenna and MOP algorithm for multiple satellites, no jammer scenarios.

4.2. SCORE METHOD

Figure 10 shows the antenna gain patterns generated using SCORE algorithm. The input signals for the four patterns contain one, two, three and eight GPS signals respectively. The antenna array used for the simulation has 4-elements. The SCORE algorithm generates satisfactory results for one and two satellite scenarios. For the three and eight satellite scenarios, the algorithms can not operate optimally.

The performance of the SCORE algorithm does improve as the number of antenna elements increases. Figure 11 is the result of using a 9-element antenna array for the same simulation signals used to generate the last two patterns shown in Figure 10.

The addition of jammers will further influence the beam pattern. Future simulation will be conducted to study this problem.

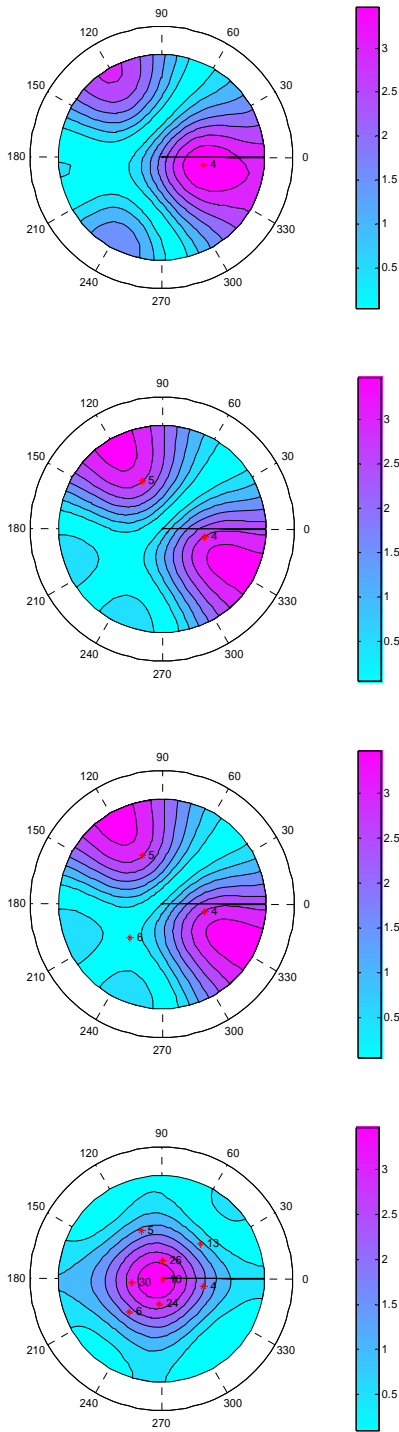

Fig. 10. Simulated antenna gain pattern using 4-element antenna and SCORE algorithm for single and multiple satellites, no jammer scenarios.

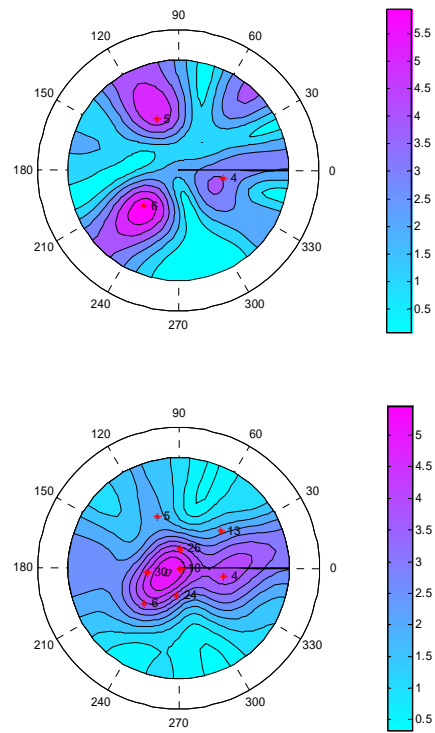

Fig. 11. Simulated antenna gain pattern using 9-element antenna and SCORE algorithm for multiple satellites, no jammer scenarios.

5. EXPERIMENTAL DATA ANALYSIS

A total of 33 sets of experimental data containing GPS and jamming signals were taken for this study. The following subsections will present the results of the MOP and SCORE beam forming algorithms and software receiver acquisition performance based on the experimental data processing.

5.1. MOP METHOD

Among the 33 sets of experimental data, there are 6 sets containing single FM chirp, 6 sets containing single BPSK, and 21 sets containing single and multiple broadband interference sources. Figures 12 through 20 summarize the beam forming and receiver acquisition results of these experimental data. Figure 12, 14, 16, and 18 compares the average number of successful GPS signal acquisition in the presence of FM chirp, BPSK, single broadband, and multiple broadband interference sources, while Figure 13, 15, 17, and 19 compares the post-acquisition signal to noise ratio for the successfully acquired signals. It is evident from these figures that the MOP method worked effectively to cancel FM chirp and BPSK interferences at all interference power level tested. The method is also functional to some degrees when dealing with single broadband jamming source. For

multiple broadband jamming sources, its performance degrades considerable at the 30 and 40 dB JSR levels.

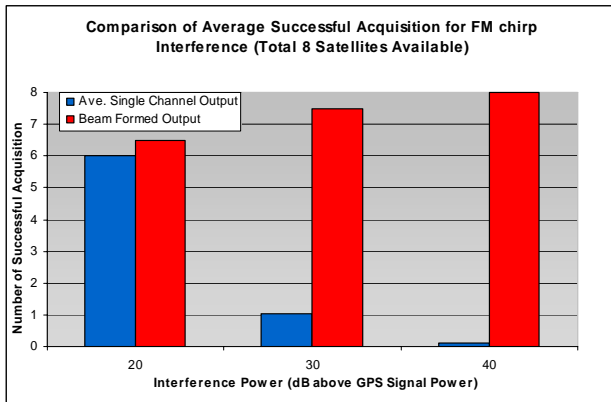

Fig. 12. Average number of successful GPS signal acquisition in the presence of FM chirp interference

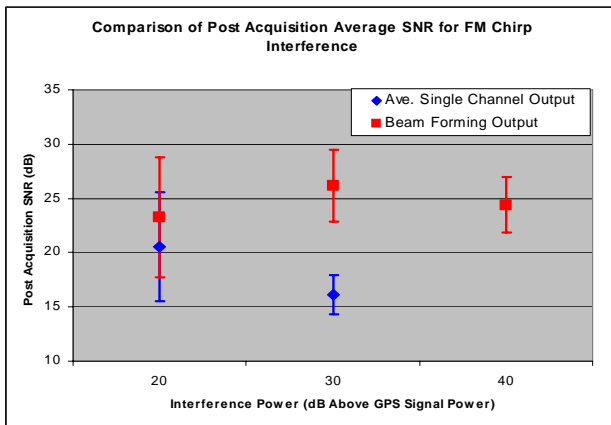

Fig. 13. Average post-acquisition GPS signal to noise ratio in the presence of FM chirp interference

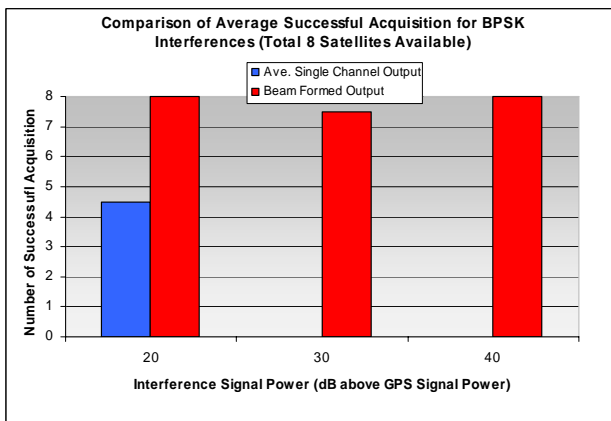

Fig. 14. Average number of successful GPS signal acquisition in the presence of BPSK interference.

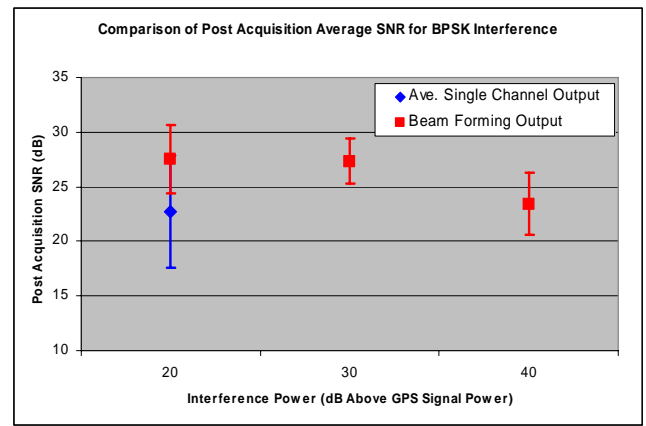

Fig. 15. Average post-acquisition GPS signal to noise ratio in the presence of BPSK interference

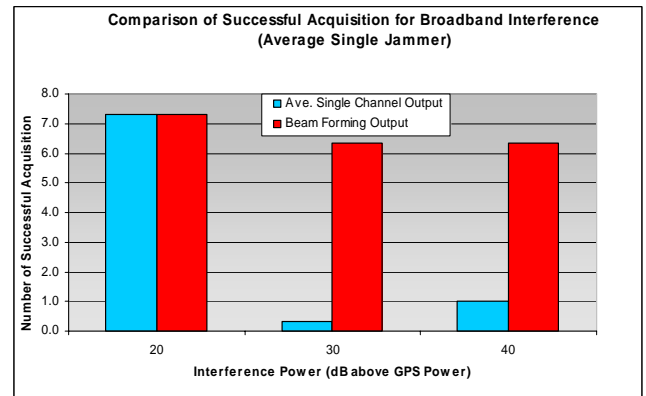

Fig. 16. Average number of successful GPS signal acquisition in the presence of single broadband interference.

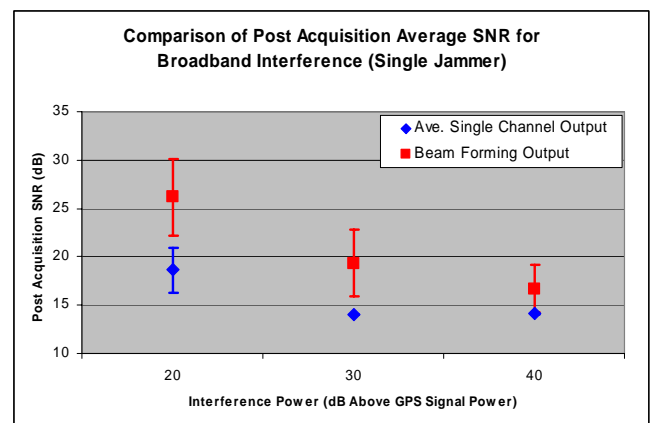

Fig. 17. Average post-acquisition GPS signal to noise ratio in the presence of single broadband interference

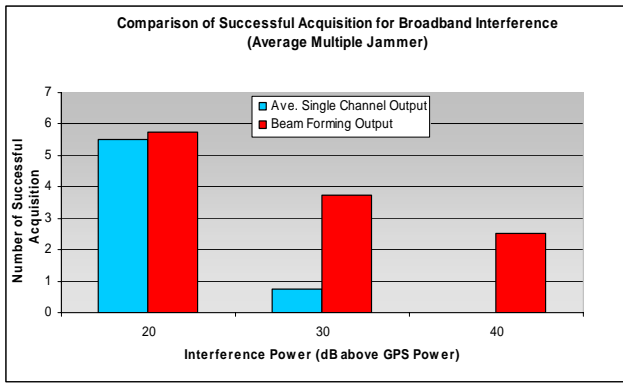

Fig. 18. Average number of successful GPS signal acquisition in the presence of multiple broadband interferences.

that using single beam constraint, while the three-beam constraints cannot generates satisfactory weighted output.

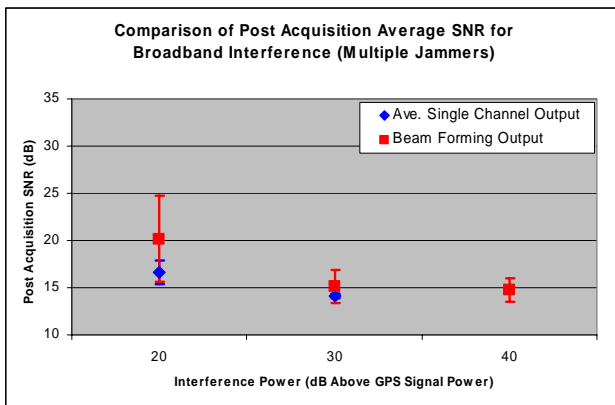
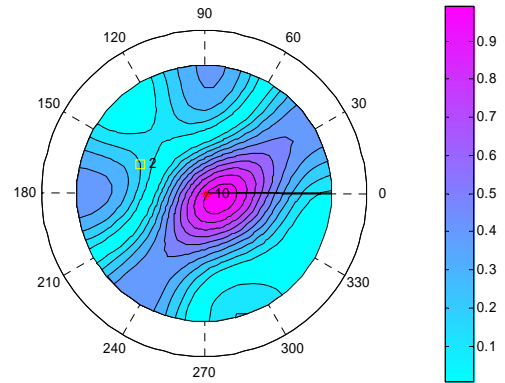
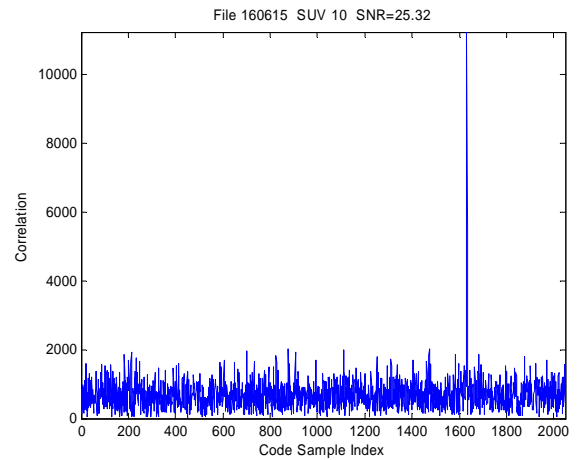

Fig. 19. Average post-acquisition GPS signal to noise ratio in the presence of multiple broadband interferences.



(a)

The following groups of figures (Figure 20 (a)-(f)) show some examples of the antenna gain pattern and receiver acquisition results. Antenna gain pattern and software GPS receiver acquisition stage correlation code phase output for experimental data collected using a 4-element antenna are plotted in this group of figures. Figures 20 (a), (b), and (c) show the results for single jammer, single beam constraint for 40 JSB FM chirp, BPSK, and broadband respectively. Figure 20 (d) and (e) shows the outputs involving two and three broadband jammers. Broadband jammer sources with JSR=40 dB are included in the data for both figures. A single satellite is used to constraint the beam direction. In Figure 20 (f), a single broadband jammer (JST=40 dB) is included in the data and two satellites are used to constraint the beam forming algorithms.

Additional processing is performed for two and three beam constraints using the MOP method. The general conclusion is that post-acquisition signal to noise ratio of satellites using two-beam constraints is compatible with

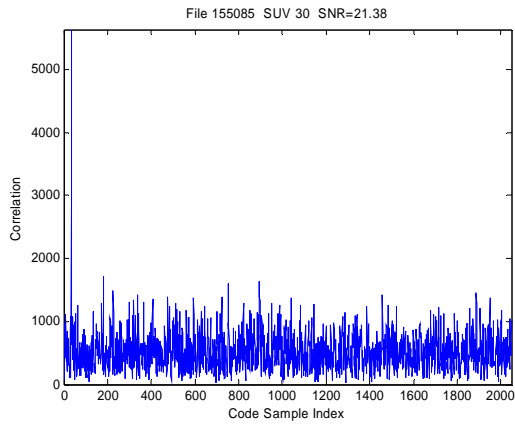
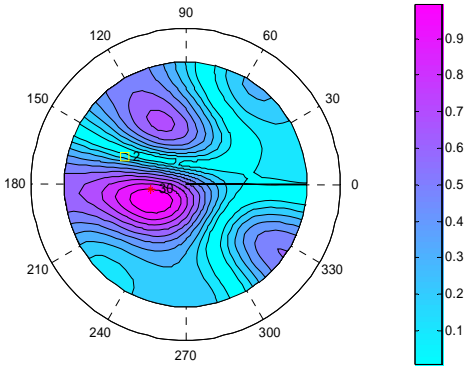

(b)

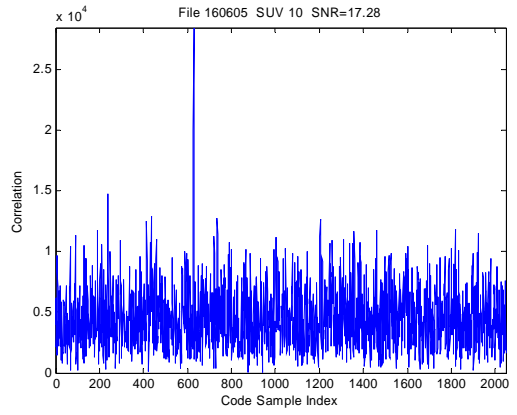
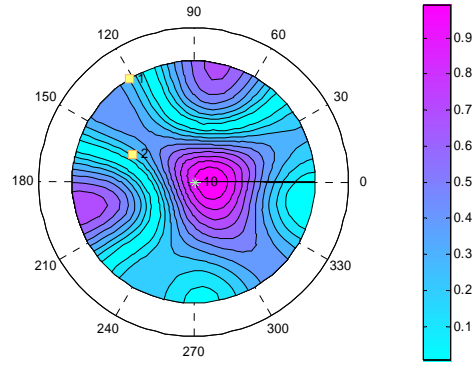

(d)

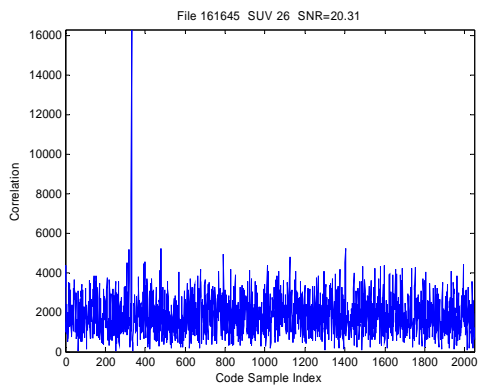
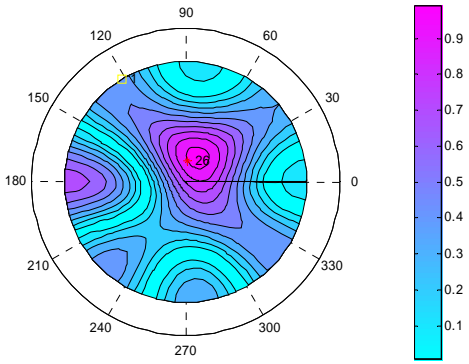

(c)

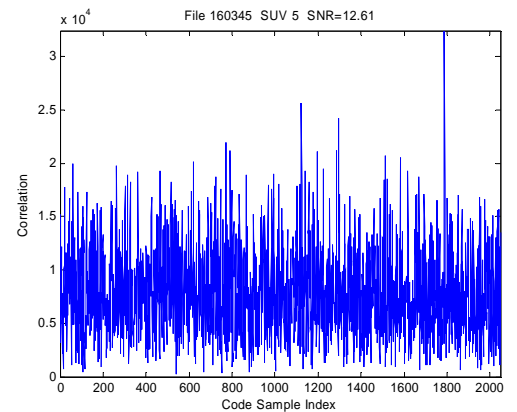
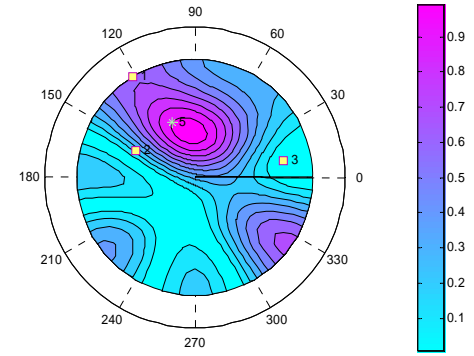

(e)

JSR=30 dB each, respectively. Broadband jammers are contained in all four data files. As can be seen that the SCORE beam forming algorithm places nulls in an inconsistent manner in the patterns. This is understandable since there are a total of eight satellites in the experimental setups while only 4 antenna elements are used to collect the data.

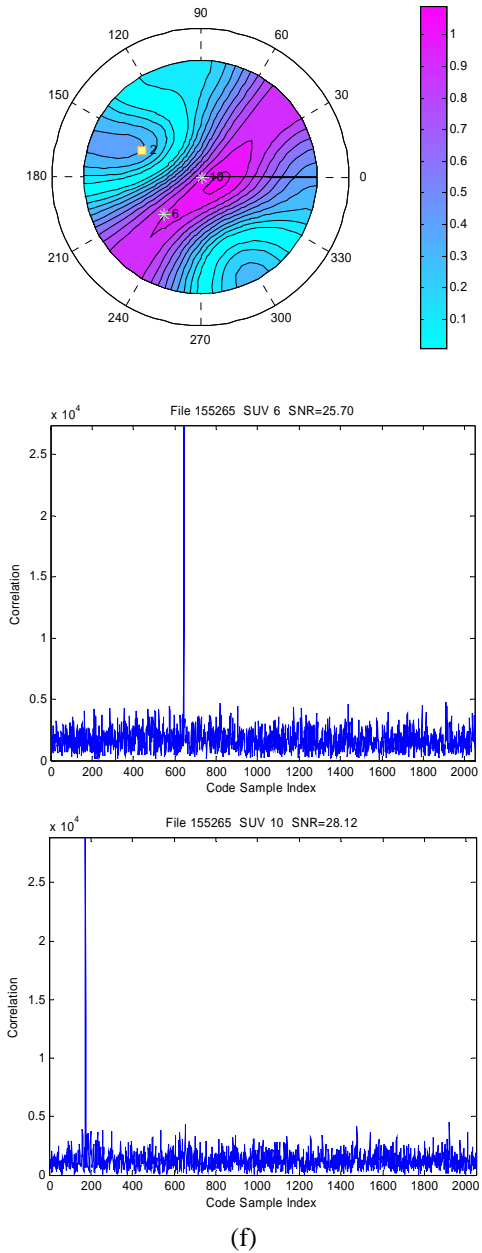
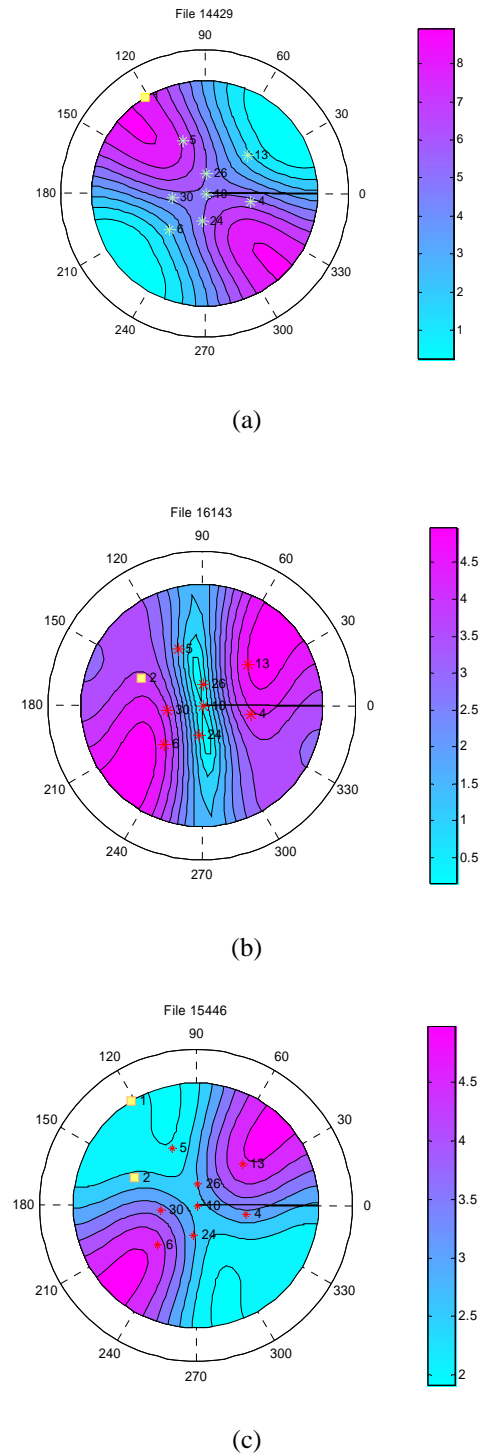
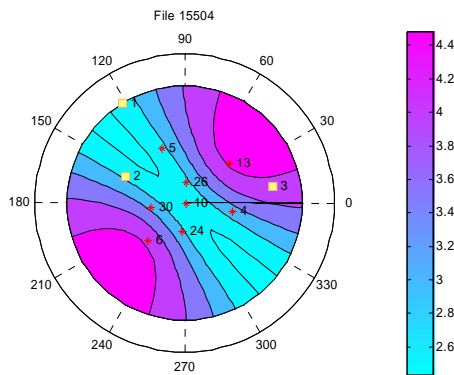

Fig. 20 (a)-(f). Antenna gain patterns and receiver acquisition results for experimental data collected using a 4-element antenna array. The results is obtained using MOP method.

5.2. SCORE METHOD

The SCORE method did not generate outputs that lead to consistent acquisition results. Figure 21 shows four sample antenna gain pattern generated for data containing a variety of jamming sources. Figure 21(a), (b), (c), and (d) each contains a single jammer with JSR=20 dB, a single jammer with JSR=40 dB, two jammers with JSR=40 dB each, and three jammers with





(d)

Fig. 21 (a)-(d). Antenna gain pattern for experimental data collected using a 4-element antenna. SCORE algorithm is used to obtain the results.

6. CONCLUSIONS AND FUTURE WORKS

This paper presented results of integrating two digital beam forming algorithms, minimum output power and SCORE, with a software GPS receiver to study the effectiveness of the beam forming algorithms. Both experimental and simulation data are used to test and evaluate the performance of these algorithms. The software GPS receiver is used to perform signal acquisition of the beam former output. Our study showed that MOP can be an effective interference cancellation technique when satellite signal angle of arrival is known and when enough degrees of freedom are available. Our experimental results show that the MOP method works with all 3 types of interference sources with JSB up to 40 dB.

Our experience with the SCORE method suggests that it requires large numbers of antenna elements when the number of available satellites is large. It will produce erroneous results if a jammer also has spectrally self-coherent properties. Because of its sensitivity to the special spectral self-coherent properties of the CA code, it may be used for ground-based jammer identifications.

The study shows that integrating beam forming algorithm with Software GPS receiver can provide a powerful means to develop anti-jam receivers.

For future works, more experiments involving different types of antenna elements, antenna layout configurations, more receiver input channels, jammer and satellite configurations, jammer types and power levels should be carried out. Additional simulation works need to including jammers. Analysis using tracking and position calculations will also be investigated in the future.

REFERENCES

- Agee, B. G., S. V. Schell, W. A. Gardner, "Spectral self-coherence restoral: a new approach to blind adaptive signal extraction using antenna arrays," *Proc. of IEEE*, vol. 78, No. 4, pp753-767, April 1990.
- Aimin, M., W. Sun, and A. Lindsey, "Adaptive arrays for GPS receivers," in M. Ibnkahla Ed., *Signal Processing for Mobile Communications Handbook*, CRC Press, 2003.
- Aimin, M., L. Zhao, and A. Lindsay, "Subspace array processing for the suppression of FM jamming in GPS receivers," to appear in *IEEE Trans. Aerospace Electronics Systems*.
- Blazquez R., J. M. Blas, and J. I. Alonso, "Implementation of adaptive algorithms for array processing in real time. Applications to low cost GPS receivers," *Proc. 49th IEEE Vehicular Technology Conf.*, pp463-467, 1999.
- Fante, R. L. and J. J. Vacarro, "Cancellation of jammers and jammer multipath in a GPS receiver," *IEEE Aerospace Electronic System Magazine*, Vol.13, No.11, pp25-28, Nov. 1998.
- Fante, R. L. and J. J. Vacarro, "Wideband cancellation of interference in a GPS receive array," *IEEE Trans. Aerospace Electronic Sys.*, Vol.36, No.2, pp549-564, Apr. 2000.
- Godara, L. C., *Smart Antennas*, CRC Press, p29, 2004.
- Hatke, G., "Adaptive array processing for wideband nulling in GPS systems," *Proc. 32nd Asilomar Conf. Signals, Systems Computers*, Vol.2, pp1332-1336, 1998.
- Liou, L. L., J. B. Tsui, D. M. Lin, S. L. Osman, C. R. Burneka, J. Shaw, and J. Valentine, "Jamming cancellation using a 2 by 2 GPS antenna array and a digital beam forming algorithm," Technical Report, Sensors Directorate, Air Force Research Laboratory, Wright Patterson Air Force Base, 2001.
- Liou, L. L., J. B. Tsui, D. M. Lin, S. L. Osman, C. R. Burneka, J. Shaw and J. Valentine, "Phase calibration of a 2 by 2 GPS antenna array using real and simulated GPS signals," *2002 Antenna Meas. Tech. Association Ann. Meeting Symp.*, pp.247-252, Nov., 2002
- Moelker, D., E. van der Pol, and Y. Bar-Ness, "Adaptive antenna arrays for interference cancellation in GPS and GLONASS receivers," *Proc. IEEE 1996 PLANS Symp.*, pp. 191-198, 1996.
- Sun, W. and M. Aimin, "A self-coherence based GPS Anti-jamming receiver," Submitted to *IEEE Trans. Signal Processing*, 2003.
- Zhang, Y., M. Aimin, and A. R. Lindsey, "Anti-jamming GPS receivers based on bilinear signal distributions," *Proc. MILCOM 2001*, Vol 2, pp.1070-1074, 2001.
- Zoltowski, M. D. and A. S. Gecan, "Advanced adaptive null steering concepts for GPS," *Proceedings of the 1995 MILCOM*, vol.3, pp1214-1218, 1995.