

# Joint Synthetic Battlespace Desert Pivot Experiment (JDPE)

*S. David Kwak, PhD*  
ESC-CXE, The MITRE Corporation  
781-271-6431  
[dkwak@mitre.org](mailto:dkwak@mitre.org)

*Lt. Col. Emily Andrew*  
ESC/CXE  
781-377-6421  
[Emily.Andrew@hanscom.af.mil](mailto:Emily.Andrew@hanscom.af.mil)

*Capt. Jack Murtha*  
ESC/CXE  
781-377-9042  
[John.Murtha@hanscom.af.mil](mailto:John.Murtha@hanscom.af.mil)

*Lt. Don Brown*  
ESC/CXE  
781-377-0312  
[Don.Brown@hanscom.af.mil](mailto:Don.Brown@hanscom.af.mil)

Keywords:

Joint Synthetic Battleship (JSB), Joint Synthetic Environment (JSE), JTA (Joint Technical Architecture), Distributed Mission Training (DMT), Weather, Analysis, Training, Engineering, Acquisition, Intelligence Surveillance, and Reconnaissance (ISR)

**ABSTRACT:** *The goal of the Joint Synthetic Battlespace Experiment (JDPE) is to prove the underlying concept of the Joint Synthetic Battlespace (JSB) in the context of the warfighters, i.e., USAF operational users. The JSB has been conceptualized and prototyped to support the transforming USAF into a capability oriented standard, such as Global Strike Task Forces (GSTF), rather than the current weapon platform centric. The new capability can only be realized by synergistic integration of existing and new weapons/C2/ISR systems. JSB plans on being the very tool for CONOP development, R&D, acquisition, training, mission planning, rehearsal, and even disposal of component systems in the future USAF.*

*Initially, JSB was focused on supporting new weapon/C2/ISR system conceptualization, development, and acquisition. The next application domain is USAF operational use. Air Combat Command's (ACC) Tactical Air Command and Control Simulation Facility (TACCSF) conducts a quarterly Desert Pivot (DP) exercise in conjunction with Red Flag of Nellis AFB. The first JSB Experiment, which is called JDPE Event 1, was conducted during DP 03-01 in October, 2002. This paper discusses the JDPE architecture and the details of the JDPE Event 1.*

## 1 Introduction

In the USAF, there is a newly emerging need to support development, acquisition, and deployment of the USAF Task Forces. For example, the Global Strike Task Force (GSTF), which is one of the TFs, requires a full integration of all existing and newly developed systems to achieve the new level of synergistic capability of the GSTF. However, the currently

available systems have been developed in a stove-piped fashion, and they do not facilitate such integration of the GSTF. Consequently, by simply putting together the legacy systems, the desired synergistic capability cannot be achieved. The synergism has to be explicitly crafted by a careful plan and implementation effort.

Therefore, designing the GSTF, which has never been conceptualized nor implemented before, is a really

# Report Documentation Page

Form Approved  
OMB No. 0704-0188

Public reporting burden for the collection of information is estimated to average 1 hour per response, including the time for reviewing instructions, searching existing data sources, gathering and maintaining the data needed, and completing and reviewing the collection of information. Send comments regarding this burden estimate or any other aspect of this collection of information, including suggestions for reducing this burden, to Washington Headquarters Services, Directorate for Information Operations and Reports, 1215 Jefferson Davis Highway, Suite 1204, Arlington VA 22202-4302. Respondents should be aware that notwithstanding any other provision of law, no person shall be subject to a penalty for failing to comply with a collection of information if it does not display a currently valid OMB control number.

1. REPORT DATE <b>2003</b>		2. REPORT TYPE		3. DATES COVERED <b>00-00-2003 to 00-00-2003</b>	
4. TITLE AND SUBTITLE <b>Joint Synthetic Battlespace Desert Pivot Experiment (JDPE)</b>				5a. CONTRACT NUMBER	
				5b. GRANT NUMBER	
				5c. PROGRAM ELEMENT NUMBER	
6. AUTHOR(S)				5d. PROJECT NUMBER	
				5e. TASK NUMBER	
				5f. WORK UNIT NUMBER	
7. PERFORMING ORGANIZATION NAME(S) AND ADDRESS(ES) <b>MITRE Corporation, 202 Burlington Road, Bedford, MA, 01730-1420</b>				8. PERFORMING ORGANIZATION REPORT NUMBER	
9. SPONSORING/MONITORING AGENCY NAME(S) AND ADDRESS(ES)				10. SPONSOR/MONITOR'S ACRONYM(S)	
				11. SPONSOR/MONITOR'S REPORT NUMBER(S)	
12. DISTRIBUTION/AVAILABILITY STATEMENT <b>Approved for public release; distribution unlimited</b>					
13. SUPPLEMENTARY NOTES <b>The original document contains color images.</b>					
14. ABSTRACT					
15. SUBJECT TERMS					
16. SECURITY CLASSIFICATION OF:			17. LIMITATION OF ABSTRACT	18. NUMBER OF PAGES <b>9</b>	19a. NAME OF RESPONSIBLE PERSON
a. REPORT <b>unclassified</b>	b. ABSTRACT <b>unclassified</b>	c. THIS PAGE <b>unclassified</b>			

daunting task. The complexity will easily bog down our cognition capability, and we surely need a good tool that augments our limited cognition ability, and is able to fully support our effort of conceptualization, design and implementation of the GSTF. Unfortunately, no existing tool currently exists.

The JSB (Joint Synthetic Battlespace) [1, 2] is able to represent the full scope of the GSTF inside the computers – i.e., in the cyber space. Then the JSB allows for us to conceptualize, to design and to test the GSTF without having a single physical component of the GSTF. That is, the JSB is the tool that allows for visualization of the future GSTF and makes us to experience the GSTF that will be available in future.

During FY03, the JSB effort has been tasked by Air Force senior leadership to refine its concept through a series of proof of concept experiments. The primary purpose of these experiments is to show how the JSB can provide support for both the operator and acquisition community users. These proof-of-concept experiments will be held in the context of the existing events such as Desert Pivot (DP), and the Joint Distributed Engineering Plant (JDEP), [3] while leveraging those activities. This paper captures the first experiment being executed in conjunction with the DP events, which is called JSB Desert Pivot Experiment (JDPE) Event 1. The DP Event was conducted at the Theater Aerospace Command and Control Simulation Facility (TACCSF). The JSB development effort was managed by the Electronic Systems Center (ESC). The JDEP Event 1 was conducted by remotely connecting the TACCSF DP facility and the JSB in Command and Control Enterprise Integration Facility (CEIF) of ESC over a classified long haul network between two facilities. The JDPE Event 1 occurred during October 28 through November 1, 2002.

## 2 Goals of JDPE Events

The vision of the JSB is to provide a simulation capability that can support a number of different types of users – including the operator and the acquisition communities. This vision is approached by providing authoritative representations of warfighting capabilities and the natural environment that can be easily integrated to create a realistic depiction of the operational battlespace. This “synthetic” battlespace can then be used to support operational activities such as training, mission rehearsal, mission planning, and decision support as well as the acquisition of warfighting capabilities that include concept definition, development, test, deployment, and sustainment. The primary goal of the FY03 DP events involving the JSB

is to experimentally prove how a common simulation capability can support both the operator and the acquisition community users. A secondary goal is to evolve a common simulation capability so it can better support both communities of users. The Desert Pivot Exercises can provide a realistic environment by portraying a natural real world setting: front-line warfighting capability and remotely located engineering support.

## 3 JDPE Objectives

To accomplish the above experiment goals, a representative engineering problem of importance to the warfighter was examined using the same simulation capability that supports the DP events. The DP simulation capability has previously always been used to support warfighter operational readiness. Additionally, if needed, the DP simulation components are slightly modified so they can better support the analysis of the selected engineering problem and operator readiness. For JDPE event 1, the assessment of an Intelligence Surveillance, and Reconnaissance (ISR) asset management capability has been selected as the engineering problem. The incorporation of synthetic weather into the ISR asset management capability and into the DP White Cell has been selected as a simulation capability improvement for both operator readiness and acquisition engineers. The objectives specifically are:

- Integrate an ISR asset management capability into JDPE event 1 and use the DP simulation capability to assess the impact to operator situational awareness and the ability of engineers to effectively use the simulation capability to perform the assessment.
- Integrate a synthetic weather representation into the JDPE event 1 to assess the impact to operator situational awareness (as a component of overall operator readiness) and the impact to engineers to effectively assess the ISR asset management capability.

The original intention for the ISR asset management capability was to use the ISR Manager. Due to real world contingencies and the resulting unavailability of an ISR Manager for JDPE event 1, ISR Warrior was used instead. For synthetic weather, the JSB weather service, which has its genesis in the Defense Modeling & Simulation Office (DMSO) Ocean Atmospheric Space Environment Service (OASES), was chosen. Raytheon provided the ISR Warrior capability and Northrop Grumman provided the synthetic weather service support. The original intention was to perform engineering assessments on the ISR asset management

capability and the impact of inclusion of weather in the context of Time Critical Targeting (TCT) as follows:

- Assess what standards are needed to improve the ease of integrating simulation components into the simulation capability being used for JDPE 1.
- Assess what standards are needed to improve the interoperability of simulation components participating in JDPE event 1.
- Assess what changes in accuracy to the simulation components participating in JDPE event 1 are needed to create a more realistic representation of the operational battlespace

#### 4 JDPE Approaches

To achieve the above goals and objectives, the following approaches will be used:

1. **Evolutionary spiral experimentation**  
Four events were proposed in conjunction with the quarterly DP exercises planned in FY03. Starting from a very simplistic but operationally significant event, the JDPE should continuously increase in operational and acquisition user relevance as the four events will be accomplished throughout FY03.
2. **Conduct the experiment as non-intrusive to the Desert Pivot Experiments as possible**  
Because of the importance of not impacting real world operator readiness, the JDPE events will not attempt to adversely impact the DP events and the accomplishment of the event's operator objectives.
3. **Maximize synergy of two operations at the C2 Enterprise Integration Facility (CEIF) and TACCSF**  
Due to limited resources, the success of JDPE will rely on the creative and synergistic collaboration between the DP and the JSB teams. This will require both teams to work closely together to develop an innovative approach to increase the value of the JDPE events.
4. **Employ disciplined system engineering**  
Since this is a proof of concept experiment, a disciplined systems engineering approach will be taken for each JDPE event. To accomplish this, plans for development, integration, testing, support and assessment will be generated.
5. **Adopt a well defined engineering and operational assessment**

Key to the success of the JDPE events is a rigorous assessment of the results generated during the event. A rigorous assessment will allow for the Air Force to quantitatively understand what JSB capabilities are needed, the needed technology, and the desired approach to provide a useful capability that supports both the operator and acquisition community users.

#### 5 The JSB DP Experiment (JDPE) Architecture

The comprehensive JDPE Architecture is shown in Figure 1. It includes the weather service plus two possible configurations for providing the ISR asset management capability/functionality by either ISR Warrior or ISR Manager.

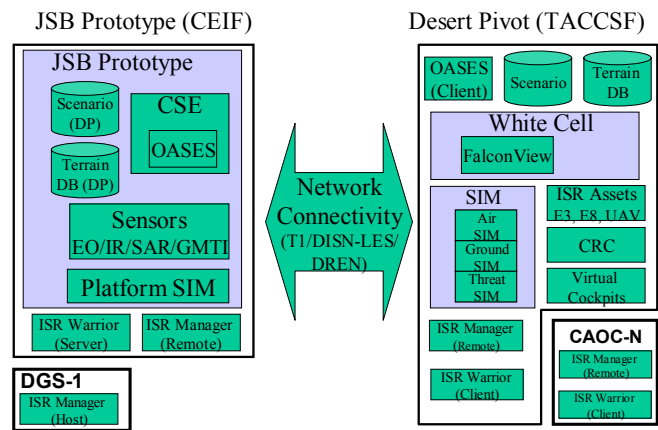

Figure 1: JSB Desert Pivot Experiment (JDPE) Architecture

##### 5.1 C2 Enterprise Integration Facility (CEIF)

The CEIF has the JSB prototype and provides ISR Management Server Functionality to the JDPE.

##### JSB Prototype

It is composed of sensor simulation components (EO/IR/SAR/GMTI), platform simulation components (F-15E, JSTARS, AWACS, RJ, Pelican, Ground Vehicles, SAM Threats, etc), and the Common Synthetic Environment (CSE), which is a correlated multi-spectrum dynamic synthetic environment. The CSE also has a weather component called OASES which is able to act as a synthetic weather generator.

##### ISR Management Server Functionality

The ISR asset management capability means both ISR Management Server and Client functionalities. The CEIF provides the ISR Management Server

functionality and associated engineering support to the client. The server functionality is represented in Figure 1 by either the ISR Warrior Server or the ISR Manager Remote in conjunction with an ISR Manager Host. When available for future JDPE events, the ISR Manager Host will be physically located in either the DGS-1 or at a Northrop Grumman facility.

## 5.2 TACCSF

TACCSF has the DP exercise support capability and the client functionalities provided by the JDPE event.

### DP Exercise Support Capability

The TACCSF supports DP exercises with three major capabilities. These include virtual simulations composed of C2 ISR assets (i.e., E3, E5, UAV virtual simulators), CRC, and reconfigurable cockpit simulators; constructive simulation, which has three components: air, ground and threat simulations with each of them represented by STAGE, JCATS, and MSIM, respectively; and the White Cell operation, which creates a realistic operational environment by controlling and intervening in the operations of the constructive simulation in the TACCSF.

### Weather Client

An OASES client provides the weather client function. This function was added to the White Cell in the TACCSF so that real time or, if needed, simulated weather effects can be added to the TACCSF's simulation capability.

### ISR Management Client Functionality

The ISR Management Client functionality can be provided by either an ISR Warrior Client or ISR Manager Remote. This functionality was initially added to the White Cell located at the TACCSF to improve and to assess the ISR asset management capability.

### Combined Air Operational Center–Nellis (CAOC-N)

The (CAOC-N) participates in DP Exercises. The plan is to provide the ISR Management Client function in CAOC-N in future JDPE events by providing a ISR management client at the CAOC-N from a server located at the CEIF.

## 5.3 Network Connectivity

The TACCSF and CEIF were connected through the available network. ISDN Integrated Services Digital Network (ISDN), T1, Defense Information System Network Leading Edge Services (DISN-LES), and Defense Research Engineering Network (DREN) were possible connection options. However, due to the

timely availability of the ISDN, the ISDN connectivity was selected for JDPE event 1.

## 6 JDPE Event 1 Architecture

As stated, the JDPE may include four events in FY03 with each occurring during the scheduled quarterly DP exercises. The events will gradually increase in complexity and capability. The first two events are planned to incur no or little change to the current TACCSF simulation models by making the human operators in the White Cell consume new data/information that are available through the weather client and ISR Management Client function. The third and fourth events could result in modifications to the TACCSF simulation models so they can use the newly available weather and ISR asset management data directly. Throughout the four events, the goal is to evolve the current simulation capability used for the DP exercises to be more supportive of operators and acquisition engineers' needs concurrently.

Therefore, the JDPE Event 1 was planned as the least intrusive joint experiment event, and executed in conjunction with DP 03-01, which was the first DP Exercise in FY03. The detailed Event 1 Architecture is shown in Figure 2.

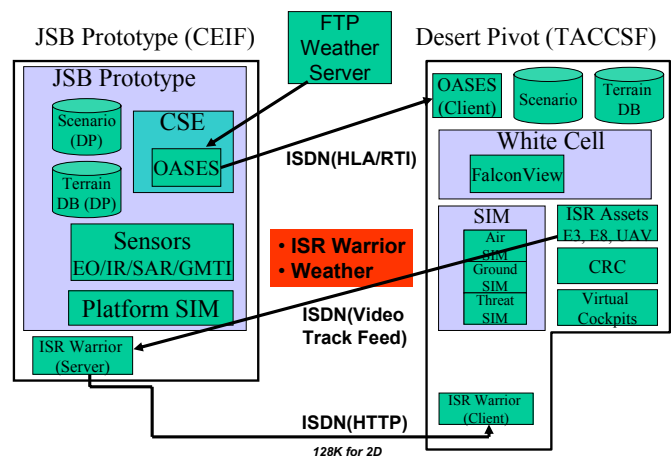

**Figure 2: JDPE Event 1 Architecture and Data Flow**

As shown in Figure 2, the data generated by the JDPE was not directly consumed by the simulation models in the TACCSF during the DP Exercise 03-01. Instead, the data generated by the JDPE was provided to the White Cell operators through the OASES weather client and the ISR Warrior Client. Both clients' Graphical User Interfaces (GUIs) were provided for the White Cell operators.

To provide the weather data, the FTP weather server was planned to feed real time weather to the OASES server, which is located in the CEIF<sup>1</sup>. Then, the OASES server converted the real time weather into data compatible with HLA/RTI and sent the data to the OASES client, which was located in the TACCSF, through the RTI that connects between TACCSF and CEIF over the ISDN connection. The 3D/2D graphics GUI terminal of the OASES client then displayed weather for the White Cell operators. The OASES server was also capable of generating weather synthetically of virtually any type.

The ISR Warrior Server, which is comprised of the ISR information processing server with a GUI for human operator interactions and a web server, provides the processed ISR data to the ISR Warrior client. As such, the ISR Warrior client is essentially a web browser that receives the ISR Warrior information from the ISR Warrior Web server. The ISR Warrior server, on the other hand, accepts raw ISR data from the ISR assets as its inputs. During JDPE event 1, the UAV simulator in the TACCSF (i.e., AFSERS) fed video to the ISR Warrior server located in the CEIF.

As mentioned above, ISDN had been selected to connect the CEIF and TACCSF due to the ready availability of the ISDN for both sites in October 2002. However, the bandwidth was quite narrow to 128Kbps which limited the amount of information exchanged between the two sites. Even so, a preliminary analysis showed that the ISDN was able to meet the bandwidth requirements of the JDPE Event 1. The preliminary bandwidth analysis is shown in Table 1 and Table 2.

**Table 1: Bandwidth Requirement of Data Traffic from CEIF to TACCSF for JDPE Event 1**

Data traffic from CEIF to TACCSF			
From	To	Bandwidth	Comm Channel
ISR Warrior Server	ISR Warrior Client	100Kbps	ISDN
OASES Server	OASES Client	28Kbps	ISDN

<sup>1</sup> The live FTP weather data feed was planned. However, the live feed option was dropped due to the long certification process. Instead, a “sneaker net” approach is adopted. The weather data is periodically recorded on a CDROM, and loaded to the weather server. Obviously, this situation will be more automated for the subsequent events planned during FY03.

**Table 2: Bandwidth Requirement of Data Traffic from TACCSF to CEIF for JDPE Event 1**

Data traffic from TACCSF to CEIF			
From	To	Bandwidth	Comm Channel
UAV Video	ISR Warrior Client	100Kbps	ISDN
ISR Asset Tracks	ISR Warrior Client	28K	ISDN

Although the UAV video feed requires as high as 3 Mbps or more if a conventional approach is used, for the Event 1, a special video compression technology called MJPEG (Motion JPEG) is adopted. This approach allows for transmitting the UAV video over a 100K bandwidth communication pipe such as our ISDN connectivity. By the way, pushing the UAV Video through such a narrow bandwidth actually mimics a real world situation in which only is a limited bandwidth available. The JDPE planned assessment of the impact on the performance of ISR management and captured the engineering performance data during the JDPE event 03-01.

## 7 JDPE Event 1 Network and System Diagram

### 7.1 CIEF Network and System Diagram for JDPE Event 1

The JDPE Event 1 connected the TACCSF and the CEIF through ISDN. Data communication over the ISDN connectivity was enabled by the ADTRAN Modem. The data stream in and out of the ADTRAN Modem was encrypted/decrypted by a KIV-7 crypto device. The decrypted data went through the CISCO route and was connected to the 100 BaseT Ethernet Local Area Network (LAN). This connectivity is shown in Figure 3.

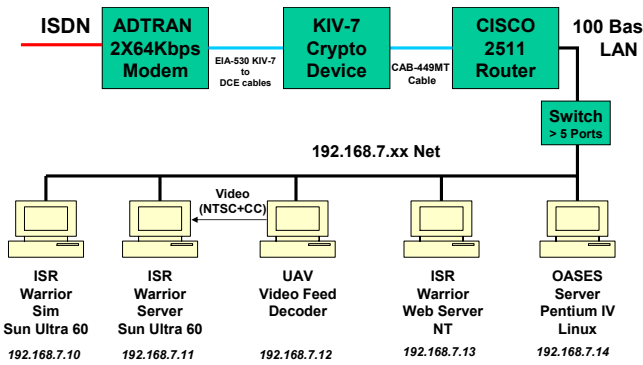

**Figure 3: CEIF Network External and Internal Connectivity for JDPE Event 1**

The data traffic input from the CEIF to the TACCSF was encrypted by a KIV-7 Crypto Device.

The 100 BaseT Ethernet LAN in the CEIF connected the OASES Weather Server (Linux), the ISR Warrior Server (2 Sun Ultra 60 workstations), and the ISR Warrior Web Server (NT) as also shown in Figure 3.

The specifications of the systems for Event 1 at the CEIF are shown in Table 3:

**Table 3: System H/W and S/W Spec at CEIF for Event 1**

System Name	H/W Spec	OS	Software
ISR Warrior (Server)	2 Sun Ultra-60	SunOS 2.6	ISR Warrior SW
ISR Warrior (Web Server)	1 NT Web Server	Windows 2000 Professional	Apache Web Server SW
OASES (Server)	1 Linux Pentium IV PC	Linux Redhat 7.2	OASES V1.0 Server
Video Decoder	Enerdyne LNX7000 MJPEG Decoder	Linux Kernel	Enerdyne LNX7000 MJPEG Decoder SW

**TACCSF Network and System Diagram for Event 1**

The ISDN network in TACCSF essentially used the same equipment as described above for the CEIF. This configuration is shown in Figure 4. As shown in the

figure, two workstations were connected to the CISCO route through the 100 BaseT Ethernet in the TACCSF: one for the OASES Client and the other for the ISR Warrior Client.

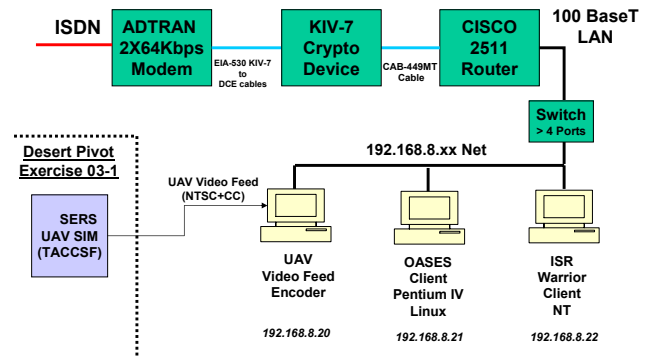

**Figure 4: TACCSF Network and System Diagram for Event 1**

The specifications of the computer hardware and software at the TACCSF are listed in Table 4:

**Table 4: System H/W and S/W Spec at TACCSF for Event 1**

System Name	H/W Spec	OS	Software
ISR Warrior (Client)	1 NT Pentium IV PC	Windows 2000 Professional	MS Internet Explorer Version 6.0
OASES (Client)	1 Linux Pentium IV PC	Linux Redhat 7.2	OASES V1.0 Client
Video Encode	Enerdyne LNX 7000 MJPEG Encoder	Linux Kernel	Enerdyne LNX 7000 MJPEG Encoder SW

**8 JDPE Event 1 Key Activities**

JDPE Event 1 was performed rapidly. From the initial design to the DP participation, it took slightly less than two months. The key activities are summarized as following.

1. Design JDPE Architecture (9/13/02 – 9/26/02)
  - a. The initial version of the JDPE architecture and associated design, which was a power point briefing, was introduced during the JDPE

Event 1 initial planning conference (IPC).

- b. The JDPE architecture for Event 1 was developed. TACCSF and CEIF team collaborated to develop the architecture. Once completed, it was incorporated into the JDPE Test & Support Plan.
- 2. Establish Connectivity (9/20/02 – 10/21/02)**
- a. The first task was to identify the type of connection to be used.  
*The connectivity between the CEIF and TACCSF was investigated by both communications officers of the CEIF and the TACCSF. For the Event 1, ISDN was chosen. It was decided that a T1 connection would be pursued for implementation beginning in Event 2 or 3.*
  - b. The second task was to establish connectivity between TACCSF and CEIF at Secret Level.  
Although the ISDN connection existed between the TACCSF and CEIF prior to the JDEP Event 03-01, a MOA between the two organizations was still needed to support the JDPE Event 1. The technical glitch and the technical support issue from the provider impacted on this schedule and delayed more than one week to complete the ISDN connectivity.
- 3. Construct JDPE Test and Support Plan (9/23/02-10/07/02)**
- a. Generate First Cut JDPE T&S Plan and distributed for review (10/04/02)  
*The JDPE Test & Support Plan included the premises, objectives, goals, approach, roles and responsibilities, key events, schedule, test/integration, and assessment plan. The document also defined the scope of the experimentation.*
  - b. ESC Approval for the Version 1.0 of the JDPE T&S Plan (10/07/02).
- 4. Provide JDPE system/test engineering support (10/01/02 – 11/01/02)**
- a. CEIF System/Integration Test Engineering  
*This was composed of three tasks. JDPE Event1 Systems engineering (10/01/02 – 10/11/02); Individual System Testing at the CEIF is the second (10/07/02 – 10/11/02); and the Integration Test at the CEIF (10/14/02 – 10/18/02, was the third).*

*The last task insures the proper execution of Event 1 at the CEIF before sending the systems to be installed and tested at the TACCSF.*

- b. TACCSF Test/Integration Engineering  
*The integrated and tested product (i.e., the weather client and the ISR Warrior Client) was scheduled to be shipped to the TACCSF and installed by CEIF personnel. A minimal integration effort was required at the TACCSF because the same setup including ISDN connection was tested at the CEIF as a part of the CEIF System/Integration Test engineering process before installing in TACCSF.*

**5. Execute JDPE Event 1 (10/28/02 – 11/01/02)**

- a. JDPE Operational Assessment  
*The operational impacts on Distributed Mission Planning (DMT) due to effects of weather phenomenon and ISR Management functionality were assessed.*
- b. JDPE Engineering Assessment  
*The JDPE was also designed to support engineering assessment in the context of the DP 03-1 in both CEIF and TACCSF.*

## **9 Operational and Engineering Assessments**

The JSB participation (JDPE Event 1) in the first DP exercise 03-01 of FY2003, while successful, proved to be both challenging and exciting. After overcoming a few glitches at the start, the two systems functioned flawlessly throughout the remainder of the exercise and were well received by the personnel who took the time to view the JDPE Event 1. While specific uses of the two capabilities in the DP exercises did not come out, the TACCSF staff, DP operators, and war fighters interviewed expressed interest in the JSB environment concept. Weather effect capabilities are undergoing an independent review at TACCSF and could become part of the future training operations. There was great interest for the ISR Warrior capabilities. However, in order to be a part of regular exercises, a more focused role in the DP exercise needs to be defined. The concept behind the ISR Warrior, that is the remote server with local client, could be extended to many other simulation areas to consolidate the efforts in both sections of the white cell.

Specifically, the JDPE Event 1 team performed a deliberate operational and engineering assessment during the DP 03-01. The impact and utility of the JSB provided ISR asset management and weather effect capabilities to operator situational awareness was assessed by direct observation of the DP exercise, interviews with the operators conducted before, during, and after each day activities, and by direct observation of DP participants' interaction with the two capabilities throughout the exercise period.

The ISR management and weather systems were installed in the section of the white cell responsible for providing stimuli to the warfighters in the exercise. However, the white cell personnel had full knowledge of the scenario and the training objectives for each evening. Thus they did not have a critical need for the additional ISR capabilities provided by those systems. The DP exercise was also conducted without weather effects. Again, the utility of the weather displayed to them was minimal. Furthermore, the white cell personnel were too busy to absorb the newly introduced capability and use them in the exercise. They in the white cell did not have any available time to conduct activities outside their training duties.

Even so, TACCSF personnel are currently reviewing weather effect capabilities to have prepared a set of requirements for the exercises they will conduct. Part of this review is an analysis of weather the capability will add or detract from the training objectives they must comply with. Opponents to the addition have pointed out that warfighters have separate training to prepare them for weather effects during their operations and thus the TACCSF training does not need to be further complicated by the addition. However, they generally agree on the value of weather effects in the arena of mission rehearsal activities.

The server and client setup between the CIEF at ESC where the support engineers reside and the TACCSF where the front-line warfighters conduct a war (i.e., training in this case) was successfully executed and well conceived by the DP people in TACCSF. This portrays the future battle that USAF will fight in a network centric fashion.

Finally, the engineering data was collected in the area of network latency, bandwidth usage, and unscheduled server-down in the CEIF. The latter part simulated the server crash in the context of the remote engineering support to the front-line warfighters between the CEIF and the TACCSF. The network latency was almost constant due to the sole usage of the long haul network for the JDPE Event 1 only. Most of all, we could send a real time video image from a simulated Predator over the ISDN connection. The Enerdyne video compressor

could compress the real-time video stream to fit in a 100k bps bandwidth. The rest of the bandwidth, 28k bps, was used to support the server and client communication between the ISR Warrior and the OASES Weather Server. . The simulated server crash could stress the current server-client system design. The ISR Warrior was only the system participated in this test, which was by no means a formal assessment. The ISR Warrior could restore its normal operation without causing any client crash or requiring rebooting the client. It showed a solid robust performance under the simulated server crash scenario. The only area for improvement would be the addition of a monitor for the health of the server. The first reaction on the simulated crash from the client user was repetitive mouse clicking. Initially, the user at the client did not have the means to know the cause of the sluggish response. It could have been caused by one of the various causes: the slow operation of one of the servers, network congestion, or a server crash. It took about a minute or so before the user figured out that the server crash at the other side of the network. If the user had never been informed that there would be a server crash, the user would have been waited longer while hoping for clearing some unknown causes affecting the troubling operation. As a result, the operator's frustration level could have been much higher than that of the above simulated server crash during the JDPE if there was no pre-announcement about the simulated server crash.

## 10 Summary and Conclusion

The DP is a quarterly training exercise for operational users in the context of Distributed Mission Training (DMT). The DP provided an excellent operational environment for the JSB, and the JSB successfully proved its utility in the environment as reported in this paper. Previously, the JSB mainly reported its utility in the acquisition and engineering domains [4, 5].

The subsequent JDPE events with the TACCSF DPs will incrementally bring more capabilities to the DPs while achieving the goal JDPE architecture shown in Figure 1. When the goal JDPE architecture is fully implemented, the JSB's full capabilities will be readily available to the TACCSF DP exercise participants while significantly raising the realism and values of the DPs. Eventually, the DPs in conjunction with the JSB will be able to provide a full mission rehearsal capability in a network centric environment for USAF. Then, one of the JSB vision areas, supporting USAF operations, will be achieved. The JSB team is also currently closely working with several acquisition programs such as the Multisensor Command and Control Constellation (MC2C).

The JSB team greatly appreciates the professional and technically competent support given by the TACCSF DP personnel during the JDPE Event 1. Without their technical support and other assistance, we could have not achieved the level of success at the DP. .

## 11 References

1. USAF, *Joint Synthetic Battlespace For Simulation Based Acquisition, JSB Concept of Operations (CONOPS)*, 2001.
2. Kwak, S.D., *Joint Synthetic Battlespace Technical Architecture (JSB-TA), Version 1*, March, 2001.
3. JSB Experiment Team, *Test and Support Plan For Proof of Concept Experiment Joint Synthetic Battlespace: Desert Pivot Experiment (JDPE) Event 1*, USAF-ESC, October, 2002.
4. Kwak, S.D., Andrew, E.B., “Technical Challenges for Joint Synthetic Battlespace (JSB)”, *Proceedings of 2002 Fall Simulation Interoperability Workshop*, SISO, Orlando, FL, Sept. 9-13, 2002.
5. Andrew, E.B., Kwak, S.D., Ochotorena, D., “Experimental Approach for Understanding the Joint Synthetic Battlespace for Simulation Based Acquisition Requirement”, *SPIE 2002*, Orlando, FL, April, 2002.

## 12 Disclaimer

The author's affiliation with The MITRE Corporation is provided for identification purposes only, and is not intended to convey or imply MITRE's concurrence with, or support for, the positions, opinions or viewpoints expressed by the author.