

CDS

TECHNICAL MEMORANDUM NO. CIT-CDS 94-010
May 12, 1994

**“A State-Space Approach to Robustness Analysis
and Synthesis for Nonlinear Uncertain Systems”**

Wei-Min Lu and John C. Doyle

Control and Dynamical Systems
California Institute of Technology
Pasadena, CA 91125

Report Documentation Page

Form Approved
OMB No. 0704-0188

Public reporting burden for the collection of information is estimated to average 1 hour per response, including the time for reviewing instructions, searching existing data sources, gathering and maintaining the data needed, and completing and reviewing the collection of information. Send comments regarding this burden estimate or any other aspect of this collection of information, including suggestions for reducing this burden, to Washington Headquarters Services, Directorate for Information Operations and Reports, 1215 Jefferson Davis Highway, Suite 1204, Arlington VA 22202-4302. Respondents should be aware that notwithstanding any other provision of law, no person shall be subject to a penalty for failing to comply with a collection of information if it does not display a currently valid OMB control number.

1. REPORT DATE 12 MAY 1994	2. REPORT TYPE	3. DATES COVERED 00-00-1994 to 00-00-1994			
4. TITLE AND SUBTITLE A State-Space Approach to Robustness Analysis and Synthesis for Nonlinear Uncertain Systems		5a. CONTRACT NUMBER			
		5b. GRANT NUMBER			
		5c. PROGRAM ELEMENT NUMBER			
6. AUTHOR(S)		5d. PROJECT NUMBER			
		5e. TASK NUMBER			
		5f. WORK UNIT NUMBER			
7. PERFORMING ORGANIZATION NAME(S) AND ADDRESS(ES) California Institute of Technology, Control and Dynamical Systems, Pasadena, CA, 91125		8. PERFORMING ORGANIZATION REPORT NUMBER			
9. SPONSORING/MONITORING AGENCY NAME(S) AND ADDRESS(ES)		10. SPONSOR/MONITOR'S ACRONYM(S)			
		11. SPONSOR/MONITOR'S REPORT NUMBER(S)			
12. DISTRIBUTION/AVAILABILITY STATEMENT Approved for public release; distribution unlimited					
13. SUPPLEMENTARY NOTES					
14. ABSTRACT					
15. SUBJECT TERMS					
16. SECURITY CLASSIFICATION OF:			17. LIMITATION OF ABSTRACT	18. NUMBER OF PAGES 37	19a. NAME OF RESPONSIBLE PERSON
a. REPORT unclassified	b. ABSTRACT unclassified	c. THIS PAGE unclassified			

A State Space Approach to Robustness Analysis and Synthesis for Nonlinear Uncertain Systems

Wei-Min Lu* and John C. Doyle†

Abstract

A state-space characterization of stability and performance robustness analysis and synthesis with some computationally attractive properties for nonlinear uncertain systems is proposed. The robust stability and robust performances for a class of nonlinear systems subject to bounded structured uncertainties are characterized in terms of various types of **nonlinear matrix inequalities** (NLMIs), which are natural generalizations of the **linear matrix inequalities** (LMIs) that appear in linear robustness analysis. As in the linear case, scalings or multipliers are used to find storage functions that give sufficient conditions for robust performances; these are also necessary under certain assumptions about smoothness of the storage functions and structure of the uncertainty. The resulting NLMIs yield convex optimization problems. Unlike the linear case, these convex problems are not finite dimensional, so their computational benefits are far less immediate. Sufficient conditions for the solvability of robust synthesis problems are developed in terms of NLMIs as well. Some aspects of the computational issues are also discussed.

1 Introduction

In this paper, a state-space characterization of robust stability and/or robust performances for a class of nonlinear systems subject to bounded structured dynamic uncertainties is proposed; both analysis and synthesis problems are addressed. The basic block diagram for an uncertain system is as follows,

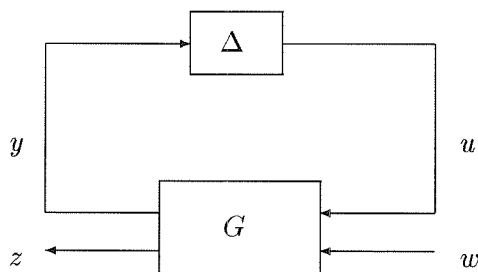

where Δ is the uncertainty which is represented as a nonlinear time invariant/varying causal operator with \mathcal{L}_2 -gain bounded by 1, G is the nominal system which is nonlinear time-invariant, w is

*Electrical Engineering 116-81, California Institute of Technology, Pasadena, CA 91125; wmlu@hot.caltech.edu.

†Electrical Engineering/Control and Dynamical Systems 116-81, California Institute of Technology, Pasadena, CA 91125.

some external disturbance vector, and z is the regulated signal vector. It is assumed that the interconnection for the uncertain system is well-posed for each admissible uncertainty. The robustness analysis is to determine that under what conditions for nominal system G , the uncertain system is stable and/or satisfies some performance for all admissible uncertainty Δ ; while the robustness synthesis problem is to decide under what conditions there are feedback control laws for the uncertain systems such that the closed loop uncertain systems have the required robustness, and then design the control law.

The systematic treatment of robustness analysis for such uncertain systems can be traced back to at least the 60's; A general sufficient condition for robust stability analysis is the small gain condition where the \mathcal{L}_2 -gain of the nominal system G is bounded by 1, i.e., $\|G\|_{\mathcal{L}_2} \leq 1$ [25, 36]. In the case where the dynamic uncertainty is unstructured, i.e. it consists just one full block, if both the uncertainty and the nominal system are linear; or the uncertainty is linear time-varying or nonlinear, and the nominal plant is nonlinear with fading memory, then the small gain condition is also necessary for robust stability [10, 7, 27, 30], where the necessity means in case $\|G\|_{\mathcal{L}_2} > 1$, there exists an admissible destabilizing perturbation Δ .

When the uncertainty Δ is structured, i.e. it consists of multiple uncertainty blocks, $\Delta = \text{block-diag}\{\Delta_1, \Delta_2, \dots, \Delta_N\}$, the sufficient small gain condition can be arbitrarily conservative for robust stability. In the case where both uncertainty and nominal system are linear time invariant, a necessary and sufficient condition for robust stability is the nominal system has small “structured gain”, i.e. its structured singular value $\mu_\Delta(G) \leq 1$ [9]. A conservative, sufficient condition for robust stability [9, 4] in this case is that the nominal system has **scaled** small gain: $\|DGD^{-1}\|_{\mathcal{L}_2} \leq 1$ for some scale D commuting with Δ . Under certain assumptions, this condition is also necessary, such as when the the nominal plant G is linear time invariant and the uncertainty is allowed to be time-varying [28, 14, 8]. Furthermore, if G is finite dimensional, the computation of the condition $\|DGD^{-1}\|_{\mathcal{L}_2} \leq 1$ can be converted to a finite dimensional **linear matrix inequality** (LMI), which is computationally attractive, (see [6] for a tutorial review of LMIs and their use.) In the case where the nominal system is nonlinear with fading memory, the uncertainty structure is linear time-varying or nonlinear, the scaled small gain is necessary as well [26], although the computational aspects are not as well resolved.

As for robust performance analysis problem, since the performance robustness analysis problem can be transferred into a robust stability problem with structured uncertainty by adding an extra “uncertainty” block [11], the above small gain arguments still apply in this case; see [11, 21, 24, 14, 8] and references therein for this consideration.

The above analysis of robust stability and performance for uncertain systems, which are treated in the input/output setting, are essentially reduced to (scaled) system gain analysis. Therefore, it is possible that the internal behaviors of the systems are ignored during the analysis in the input/output setting. In addition, the computational implications for those characterizations are not clear for the nonlinear case. These concerns can be remedied by taking a state space treatment. A basic internal consideration in the state space analysis is to see if the system is asymptotically stable. For linear systems, the asymptotic stability is guaranteed by the input/output stability if the system is detectable and stabilizable; and there are systematic ways to get such internally well-behaved realization. In particular, the \mathcal{L}_2 -stability and \mathcal{H}_∞ -performance robustness for linear systems can be easily characterized in state-space in terms of the results of \mathcal{H}_∞ -performance analysis in state space [12, 19, 22, 23, 16, 21, 1, 6]. However, the story for state-space treatment of the nonlinear systems is different, since the small gain theorem can only guarantee the system to

have bounded-input/bounded-output property; it does not reveal internal information about the systems, and there is more required to insure asymptotic stability. Moreover, the performance and robust stability problems are essentially different, although the characterizations are similar.

In this paper, we give state-space characterizations of stability and performance robustness for nonlinear uncertain system, and consider both analysis and synthesis problems. By robust stability, we mean that the feedback system is asymptotically stable for each admissible uncertainty; the robust performance means that the uncertain system is asymptotically stable and has \mathcal{L}_2 -gain ≤ 1 . The treatments of the robustness issues in this paper are motivated by the small gain theorem and its recent extensions, together with the LMI characterization of results in the linear case. Essentially, one of the main results in this paper implies that under some additional (stabilizing) conditions, if both the (structured) uncertainty and the (scaled) nominal system are bounded by 1 in \mathcal{L}_2 sense, then the uncertain system is robustly stable or has robust performance and we characterize all of the conditions in terms of **nonlinear matrix inequalities** (NLMIs).

Although other characterizations, such as Hamilton-Jacobi equations/inequalities, exist and are equivalent to the NLMIs in this paper, the characterizations in terms of NLMIs offer potentially attractive computational features. In particular, like the linear case, the NLMIs trivially give convex conditions on the unknowns. Unfortunately, the NLMI conditions involve neither a finite number of unknowns nor a finite number of constraints, so the computational advantages are far less immediate than for LMIs. Clearly much additional work will be needed on the computational aspects and sophisticated approximation techniques may be required to make the NLMI computation feasible.

The rest of the paper is organized as follows. In section 2, some results for asymptotic stability and \mathcal{L}_2 -gain analysis for nonlinear systems are reviewed, and these characterizations are reformulated as NLMIs. In section 3, the stability robustness analysis is conducted; both unstructured and structured uncertainty cases are treated independently, although the unstructured uncertainty is a special case of the structured uncertainty; the former is used to motivate the latter. In section 4, the robust performance analysis is conducted; the general structured uncertainty case is considered, and two cases where the plants are generally causal and strictly causal are dealt with respectively. The characterizations of both robust stability and robust performance are in terms of NLMIs. In section 5, we deal with the robustness synthesis problem; we just take the state feedback performance robustness synthesis problem as an example, and the solvability conditions are also in terms of NLMIs. We address some computational issues for robustness analysis and synthesis in section 6. In the concluding remarks, we briefly discuss the scaled small gain theorem for bounded-input-bounded output stability of nonlinear uncertain systems, which is the motivation for the treatments in this paper.

Conventions

The following conventions are made in this paper. \mathbb{R} is the set of real numbers, $\mathbb{R}^+ := [0, \infty) \subset \mathbb{R}$. \mathbb{R}^n is n -dimensional real Euclidean space; $\|\cdot\|$ stands for the **Euclidean norm**. \mathbf{X} (or \mathbf{X}_i) is the state set which is a convex open subset of some Euclidean space and contains the origin. $\mathbb{R}^{n \times m}$ ($\mathbb{C}^{n \times m}$) is the set of all $n \times m$ real (complex) matrices. The transpose of some matrix $M \in \mathbb{R}^{n \times n}$ is denoted by M^T . By $P > 0$ ($P \geq 0$) for some Hermitian matrix $P \in \mathbb{R}^{n \times n}$ or ($\mathbb{C}^{n \times m}$) we mean that the matrix is (semi-)positive definite. A function is said to be of class \mathbf{C}^k if it is continuously differentiable k times; so \mathbf{C}^0 stands for the class of continuous functions. A function $V : \mathbf{X} \rightarrow \mathbb{R}^+$ is positive-definite if $V(x) \geq 0$, $V(x) = 0 \Rightarrow x = 0$, and $\lim_{\|x\| \rightarrow \infty} V(x) = \infty$ on \mathbf{X} . A \mathbf{C}^0 matrix-valued function $P : \mathbf{X} \rightarrow \mathbb{R}^{n \times n}$ is positive definite if $P(x)$ is positive definite for each $x \in \mathbf{X}$ and there exist

$\alpha > 0$ such that $P(x) > \alpha I$ for all $x \in \mathbf{X}$. $\mathcal{L}_2(\mathbb{R}^+)$ stands for the function space which is defined as the set of all vector-valued functions $u(t)$ on \mathbb{R}^+ such that $\|u\|_2 := (\int_0^\infty (\|u(t)\|^2 dt))^{1/2} < \infty$, and $\mathcal{L}_2^e(\mathbb{R}^+)$ is its extended space which is defined as the set of the vector-valued functions $u(t)$ on \mathbb{R}^+ such that $P_T u(t) \in \mathcal{L}_2(\mathbb{R}^+)$ for all $T \in \mathbb{R}^+$, where P_T is the truncation operator.

2 Preliminaries

In this section, we will review some standard results about stability and \mathcal{H}_∞ -performances of a class of nonlinear time invariant systems. We will reformulate these characterizations in terms of so-called nonlinear matrix inequalities (NLMIs).

The system considered in this section has the following control affine realization,

$$G : \begin{cases} \dot{x} = f(x) + g(x)w \\ z = h(x) + k(x)w \end{cases} \quad (1)$$

where $x \in \mathbb{R}^n$ is state vector, $w \in \mathbb{R}^p$ and $z \in \mathbb{R}^q$ are input and output vectors, respectively. It is assumed that $f, g, h, k \in \mathbf{C}^0$ are vector or matrix valued function, and $f(0) = 0, h(0) = 0$. From now on we will assume the system evolves on a convex open subset $\mathbf{X} \subset \mathbb{R}^n$ containing the origin. Thus, $0 \in \mathbb{R}^n$ is the equilibrium of the system with $w = 0$. The state transition function $\phi : \mathbb{R}^+ \times \mathbf{X} \times \mathcal{L}_2(\mathbb{R}^+) \rightarrow \mathbf{X}$ is so defined that $x = \phi(T, x_0, w^*)$ means that system G is driven from initial state x_0 to state x in time T by the control action $w^* \in \mathcal{L}_2(\mathbb{R}^+)$.

Note that in many cases system (1) can be rewritten (nonuniquely) as the following form which is also used in this paper.

$$G : \begin{cases} \dot{x} = A(x)x + B(x)w \\ z = C(x)x + D(x)w \end{cases} \quad (2)$$

where $x \in \mathbb{R}^n$ is state vector, $w \in \mathbb{R}^p$ and $z \in \mathbb{R}^q$ are input and output vectors, respectively. We will assume A, B, C, D are \mathbf{C}^0 matrix-valued functions of suitable dimensions.

Definition 2.1 (i) The system (1) or (2) is **reachable** from 0 if for all $x \in \mathbf{X}$, there exist $T \in \mathbb{R}^+$ and $w^*(t) \in \mathcal{L}_2[0, T]$ such that $x = \phi(T, 0, w^*)$;

(ii) The system (1) or (2) is (zero-state) **detectable** if $w = 0$ and for all $x \in \mathbf{X}$, $z(t) (= h(\phi(t, x, 0))) = 0 \Rightarrow \phi(t, x, 0) \rightarrow 0$ as $t \rightarrow \infty$.

2.1 Asymptotic Stability

Definition 2.2 Consider the nonlinear dynamical system G . It is asymptotically stable if

$$\lim_{t \rightarrow \infty} \phi(t, x_0, 0) = 0$$

for any initial state $x_0 \in \mathbf{X}$.

We have the following results about asymptotic stability.

Proposition 2.3 (i) **(Lyapunov)** The equilibrium 0 of the system G (1) with $w = 0$ is asymptotically stable if and only if there exists a \mathbf{C}^1 positive definite function $V : \mathbf{X} \rightarrow \mathbb{R}^+$ such that $\dot{V}(x) \leq 0$, where $\dot{V}(x) = 0$ if and only if $x = 0$.

(ii) **(LaSalle)** The equilibrium 0 of the system G (1) with $w = 0$ is asymptotically stable if and only if there exists a \mathbf{C}^1 positive definite function $V : \mathbf{X} \rightarrow \mathbb{R}^+$ such that $\dot{V}(x) \leq 0$, and those $x(t)$ with $\dot{x} = f(x)$ such that $\dot{V}(x(t)) = 0$ satisfy $x(t) \rightarrow 0$ as $t \rightarrow \infty$.

The positive definite functions V in the above theorem is called **Lyapunov functions**. Note that the above Lyapunov theorem can be explicitly restated as follows.

Theorem 2.4 Consider system (1). It is asymptotically stable around 0, if

(i) there is a \mathbf{C}^1 positive definite function $V : \mathbf{X} \rightarrow \mathbb{R}^+$ such that

$$\frac{\partial V}{\partial x}(x)f(x) < 0. \quad (3)$$

for all $x \in \mathbf{X} \setminus \{0\}$ with $x \neq 0$; or

(ii) (1) is detectable, and there is a \mathbf{C}^1 positive definite function $V : \mathbf{X} \rightarrow \mathbb{R}^+$ such that

$$\frac{\partial V}{\partial x}(x)f(x) + h^T(x)h(x) \leq 0. \quad (4)$$

for all $x \in \mathbf{X}$.

Remark 2.5 It is noted that the conditions of Theorem 2.4 for stability are convex conditions. That is, in both cases, the positive solutions V satisfying (3) and (4) form convex sets, respectively. This trivial fact has only been exploited systematically in the linear case, but we hope that numerical techniques may be developed to exploit it in the nonlinear case as well.

2.2 \mathcal{L}_2 -Gains of Nonlinear Systems

Definition 2.6 The system G (1) with initial state $x(0) = 0$ is said to have \mathcal{L}_2 -gain less than or equal to γ for some $\gamma > 0$ if

$$\int_0^T \|z(t)\|^2 dt \leq \gamma^2 \int_0^T \|w(t)\|^2 dt \quad (5)$$

for all $T \geq 0$ and $w(t) \in \mathcal{L}_2^e(\mathbb{R}^+)$, and $z(t) = h(x(t)) + k(x(t))w(t)$ with $x(t) = \phi(t, 0, w(t))$.

The following results characterizes \mathcal{L}_2 -gains for a class of nonlinear systems which are asymptotically stable in terms of NLMIs. The reader is referred to [18] for more about NLMI characterizations of \mathcal{L}_2 -gains for nonlinear systems.

Theorem 2.7 Consider system G given by (1) with $R(x) = I - k^T(x)k(x) > 0$, it is asymptotically stable and has \mathcal{L}_2 -gain ≤ 1 if

(i) $[f(x), h(x)]$ is detectable, and there exist a \mathbf{C}^1 positive definite function $V : \mathbf{X} \rightarrow \mathbb{R}^+$ such that

$$\begin{bmatrix} \frac{\partial V}{\partial x}(x)f(x) + h^T(x)h(x) & \frac{1}{2} \frac{\partial V}{\partial x}(x)g(x) + h^T(x)k(x) \\ \frac{1}{2} g^T(x) \frac{\partial V}{\partial x}(x) + k^T(x)h(x) & k^T(x)k(x) - I \end{bmatrix} \leq 0, \quad (6)$$

for all $x \in \mathbf{X}$.

(ii) there exist a \mathbf{C}^1 positive definite function $V : \mathbf{X} \rightarrow \mathbb{R}^+$ such that

$$\begin{bmatrix} \frac{\partial V}{\partial x}(x)f(x) + h^T(x)h(x) & \frac{1}{2}\frac{\partial V}{\partial x}(x)g(x) + h^T(x)k(x) \\ \frac{1}{2}g^T(x)\frac{\partial V^T}{\partial x}(x) + k^T(x)h(x) & k^T(x)k(x) - I \end{bmatrix} < 0, \quad (7)$$

for all $x \in \mathbf{X} \setminus \{0\}$.

Proof By Schur's complement argument, we have that (6) is equivalent to

$$\begin{aligned} \mathcal{H}(V, x) &:= \frac{\partial V}{\partial x}(x)f(x) + h^T(x)h(x) + \\ & \left(\frac{1}{2}\frac{\partial V}{\partial x}(x)g(x) + h^T(x)k(x) \right) (I - k^T(x)k(x))^{-1} \left(\frac{1}{2}g^T(x)\frac{\partial V^T}{\partial x}(x) + k^T(x)h(x) \right) \leq 0. \end{aligned} \quad (8)$$

which is a Hamilton-Jacobi inequality [31], and implies

$$\begin{aligned} \frac{\partial V}{\partial x}(x)f(x) &\leq -h^T(x)h(x) + \\ & - \left(\frac{1}{2}\frac{\partial V}{\partial x}(x)g(x) + h^T(x)k(x) \right) (I - k^T(x)k(x))^{-1} \left(\frac{1}{2}g^T(x)\frac{\partial V^T}{\partial x}(x) + k^T(x)h(x) \right). \end{aligned}$$

Thus,

$$\begin{aligned} \dot{V}(x) &= \frac{\partial V}{\partial x}(x)(f(x) + g(x)w) \\ &= \frac{\partial V}{\partial x}(x)g(x)w - h^T(x)h(x) + \\ & - \left(\frac{1}{2}\frac{\partial V}{\partial x}(x)g(x) + h^T(x)k(x) \right) (I - k^T(x)k(x))^{-1} \left(\frac{1}{2}g^T(x)\frac{\partial V^T}{\partial x}(x) + k^T(x)h(x) \right) \\ &\leq \|w(t)\|^2 - \|z(t)\|^2 - \left\| R^{1/2}(x)w(t) - R^{-1/2}(x)k^T(x)h(x) - \frac{1}{2}R^{-1/2}(x)g^T(x)\frac{\partial V^T}{\partial x}(x) \right\|^2 \end{aligned}$$

The latter inequality follows by *completion of squares* for (2.2). Therefore,

$$\dot{V}(x) - (\|w(t)\|^2 - \|z(t)\|^2) \leq 0.$$

Take the integral from $t = 0$ to $t = T$, the above inequality implies that the system has \mathcal{L}_2 -gain ≤ 1 since $V(x) \geq 0$.

On the other hand, note that $\mathcal{H}(V, x) \leq 0$ implies

$$\frac{\partial V}{\partial x}(x)f(x) + h^T(x)h(x) \leq 0;$$

and $[f(x), h(x)]$ is detectable by the assumption, then the stability is confirmed by theorem 2.4.

(ii) By using Schur complement argument, we have that (7) is equivalent to $\mathcal{H}(V, x) < 0$ for all $x \in \mathbf{X} \setminus \{0\}$, where \mathcal{H} is defined in (8). It follows from the similar arguments as above that

$$\dot{V}(x) \leq \|w(t)\|^2 - \|z(t)\|^2 + \mathcal{H}(V, x) \quad (9)$$

$$\leq \|w(t)\|^2 - \|z(t)\|^2$$

It is easy to see that the latter inequality implies the \mathcal{L}_2 -gain ≤ 1 . Now take $w(t) = 0$, (9) becomes

$$\dot{V}(x) \leq -\|z(t)\|^2 + \mathcal{H}(V, x)$$

So $\dot{V}(x) = 0$ implies $\mathcal{H}(V, x) = 0$, which in turn implies $x = 0$. Therefore, $V : \mathbf{X} \rightarrow \mathbb{R}^+$ is a Lyapunov function, and system G is asymptotically stable. \square

Remark 2.8 *Note that conditions in Theorem 2.7 are affine in $V(x)$, and all such solutions form convex sets. These inequalities are actually differential linear (or affine) matrix inequalities, but we will refer to them as **nonlinear matrix inequalities (NLMIs)** to emphasize their use in nonlinear problems. All of the conditions that are derived for the analysis problems in the remainder of this paper are similarly convex, and this property will not be discussed for each problem.*

2.3 Further Remarks: Alternative Characterizations

It may be helpful for computation, especially in the synthesis problem, to have some alternative characterizations, instead of using (3), (6), and (7); however, the price will often be paid for increasing conservatism. For example, as in [18], system (2) is considered and (7) is replaced by the following NLMI in the characterization,

$$\begin{bmatrix} A^T(x)P(x) + P(x)A(x) + C^T(x)C(x) & P(x)B(x) + C^T(x)D(x) \\ B^T(x)P(x) + D^T(x)C(x) & D^T(x)D(x) - I \end{bmatrix} < 0. \quad (10)$$

for some positive definite \mathbf{C}^0 matrix valued function $P : \mathbf{X} \rightarrow \mathbb{R}^{n \times n}$ such that $\frac{\partial V}{\partial x}(x) = 2x^T P(x)$ for some \mathbf{C}^1 function on \mathbf{X} with $V(0) = 0$. In fact if such function P exists, (10) implies

$$\begin{bmatrix} x^T & 0 \\ 0 & I \end{bmatrix} \begin{bmatrix} A^T(x)P(x) + P(x)A(x) + C^T(x)C(x) & P(x)B(x) + C^T(x)D(x) \\ B^T(x)P(x) + D^T(x)C(x) & D^T(x)D(x) - I \end{bmatrix} \begin{bmatrix} x & 0 \\ 0 & I \end{bmatrix} < 0$$

for all $x \in \mathbf{X} \setminus \{0\}$, which is exactly (7). We will see the characterizations in terms of (10) have some computationally attractive properties.

It is noted that the NLMI (10) has positive definite solution $P : \mathbf{X} \rightarrow \mathbb{R}^{n \times n}$ implies that system (2) point-wise has \mathcal{L}_2 -gain ≤ 1 ; however, to guarantee the performance for the original system, it is additionally required that there exists a function $V : \mathbf{X} \rightarrow \mathbb{R}$ such that $\frac{\partial V}{\partial x}(x) = 2x^T P(x)$. Lemma 6.5 provides a characterization of a class of matrix-valued functions $P : \mathbf{X} \rightarrow \mathbb{R}^{n \times n}$ which satisfy this additional requirement. The same arguments are also true for the stability analysis.

To see the conservativeness of NLMI, such as (10), it may be noted that even its point-wise solution is not necessary for either stability or performance, as is well-known. This is shown in the following example.

Example 2.9 *Consider the following system of order two,*

$$\begin{cases} \dot{x}_1 = -x_1 + x_1 x_2^2 \\ \dot{x}_2 = -x_1^2 x_2 - x_2 \end{cases}$$

which evolves on \mathbb{R}^2 . Take a positive definite (quadratic) function $V(x_1, x_2) = x_1^2 + x_2^2$, which is actually a Lyapunov function for the system and satisfies (3). In fact, $\dot{V}(x_1, x_2) = -2(x_1^2 + x_2^2)$, which is negative definite; the system is therefore asymptotically stable.

On the other hand, the system can be rewritten as the form (2), i.e., $\dot{x} = A(x)x$ for $x \in \mathbb{R}^2$. There are two representations in which

$$A(x) = \begin{bmatrix} -1 + x_2^2 & 0 \\ 0 & -1 - x_1^2 \end{bmatrix} \text{ and } A(x) = \begin{bmatrix} -1 & x_1 x_2 \\ -x_1 x_2 & -1 \end{bmatrix}.$$

Obviously, neither $A(x)$'s are point-wise asymptotically stable on \mathbb{R}^2 . This may be compared to the pointwise use of (10), which is discussed further in Section 6.3.

3 Stability Robustness of Uncertain Systems

Consider the following uncertain system which is described as a feedback system set,

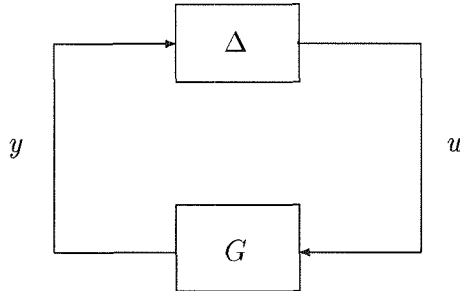

where the nominal system G has the realization similar to (2), i.e.,

$$G : \begin{cases} \dot{x} = f(x) + g(x)u \\ y = h(x)x + k(x)u \end{cases} \quad (11)$$

and the uncertainty Δ is fed back to the nominal system and belongs to a set:

$$\mathbf{\Delta} := \{\Delta : \Delta \text{ is a causal asymptotically stable nonlinear time-varying system}\} \quad (12)$$

In this section, the case where the uncertainty is norm-bounded is considered. In particular, it is assumed that Δ is in the following uncertainty subset of $\mathbf{\Delta}$.

$$\mathbf{B}\mathbf{\Delta} := \{\Delta : \Delta \in \mathbf{\Delta} \text{ and has } \mathcal{L}_2\text{-gain} \leq 1\} \quad (13)$$

Definition 3.1 *The uncertain system is **robustly stable** if for each $\Delta \in \mathbf{B}\mathbf{\Delta}$, the feedback system is well-posed and asymptotically stable around 0.*

From now on, it is always assumed that each uncertainty $\Delta \in \mathbf{\Delta}$ is fed back to the nominal system G in the well-posed manner. In this section, we examine the robust stability in two cases where the uncertainties Δ are unstructured and structured, respectively.

3.1 Systems with Unstructured Perturbations

We first examine the uncertain structure Δ in a simple case, i.e. Δ has the following input affine realization.

$$\Delta : \begin{cases} \dot{\xi} = f_d(\xi) + g_d(\xi)y \\ u = h_d(\xi) \end{cases}$$

with $f_d(0) = 0$ and $h_d(0) = 0$. It is known that Δ has \mathcal{L}_2 -gain ≤ 1 if and only if there exists a well defined storage function $U : \mathbf{X}_0 \rightarrow \mathbb{R}^+$ for this system with respect to the supply rate $\|y\|^2 - \|u\|^2$ (see [35]); if $U(\xi)$ is differentiable, then Δ has \mathcal{L}_2 -gain ≤ 1 if and only if the following Hamilton-Jacobi inequality holds (see [31]):

$$\psi(\xi) := \frac{\partial U}{\partial \xi}(\xi)f_d(\xi) + \frac{1}{4} \frac{\partial U}{\partial \xi}(\xi)g_d(\xi)g_d^T(\xi)\frac{\partial U^T}{\partial \xi}(\xi) + h_d^T(\xi)h_d(\xi) \leq 0$$

Then it can be shown that the above inequality is equivalent to

$$\dot{U}(\xi) \leq \|y\|^2 - \|u\|^2 + \psi(\xi)$$

for all possible $y(t)$. Motivated by this observation, we make the following assumption for a general uncertain nonlinear structure $\Delta \in \mathbf{B}\Delta$.

Assumption 3.2 *For each $\Delta \in \mathbf{B}\Delta$, it has the following realization:*

$$\begin{cases} \dot{\xi} = f_d(\xi, t, y) \\ u = h_d(\xi, t, y) \end{cases}$$

which evolves on \mathbf{X}_0 and $\dot{\xi} = f_d(\xi, t, 0)$ is asymptotically stable at $0 \in \mathbf{X}_0$; in addition, there exists a \mathbf{C}^1 storage function U such that $\dot{U}(\xi) \leq \|y\|^2 - \|u\|^2 + \psi(\xi)$ with some negative definite function $\psi : \mathbf{X}_0 \rightarrow \mathbb{R}^+$.

We have the following theorem regarding the robust stability.

Theorem 3.3 *Under assumption 3.2, the uncertain system is robustly stable if there is a positive definite \mathbf{C}^1 function $V : \mathbf{X} \rightarrow \mathbb{R}^+$ satisfying the following inequality:*

$$\begin{bmatrix} \frac{\partial V}{\partial x}(x)f(x) + h^T(x)h(x) & \frac{1}{2}(x)\frac{\partial V}{\partial x}g(x) + h^T(x)k(x) \\ \frac{1}{2}g^T(x)\frac{\partial V^T}{\partial x}(x) + k^T(x)h(x) & k^T(x)k(x) - I \end{bmatrix} < 0 \quad (14)$$

for all $x \in \mathbf{X} \setminus \{0\}$.

Proof Consider (14), note that that $R(x) := I - k^T(x)k(x) > 0$, by using Schur complement argument, we have that it is equivalent to the following Hamilton-Jacobi inequality:

$$\begin{aligned} \mathcal{H}(V, x) := & \frac{\partial V}{\partial x}(x)f(x) + h^T(x)h(x) + \\ & + \left(\frac{1}{2} \frac{\partial V}{\partial x}(x)g(x) + h^T(x)k(x)\right)(I - k^T(x)k(x))^{-1}(x) \left(\frac{1}{2}g^T(x)\frac{\partial V^T}{\partial x}(x) + k^T(x)h(x)\right) \leq 0. \end{aligned} \quad (15)$$

for all $x \in \mathbf{X} \setminus \{0\}$. Take V as defined in the statement, similar argument to the proof of Theorem 2.7 yields that

$$\dot{V}(x) \leq \|u(t)\|^2 - \|y(t)\|^2 + \mathcal{H}(V, x). \quad (16)$$

On the other hand, by assumption 3.2, for each $\Delta \in \mathbf{B}\Delta$, there is a positive definite function $U : \mathbf{X}_0 \rightarrow \mathbb{R}^+$, such that

$$\dot{U}(\xi) \leq \|y(t)\|^2 - \|u(t)\|^2 + \psi(\xi). \quad (17)$$

for some negative definite function ψ on \mathbf{X}_0 , where ξ is the state vector of Δ defined on \mathbf{X}_0 .

Next, define a positive definite function W on $\mathbf{X} \times \mathbf{X}_0$ as

$$W(x, \xi) = V(x) + U(\xi) \quad (18)$$

So from (16) and (17), it follows that

$$\dot{W}(x, \xi) \leq \mathcal{H}(V, x) + \psi(\xi) \leq 0$$

Thence, if $\dot{W}(x, \xi) = 0$, then $\mathcal{H}(V, x) = 0$ and $\psi(\xi) = 0$; the former condition implies $x = 0$ by (15), and the latter implies $\xi = 0$ by assumption 3.2. Thus, $W : \mathbf{X} \times \mathbf{X}_0 \rightarrow \mathbb{R}^+$ is a Lyapunov function for the feedback system, and the system is asymptotically stable. Therefore, the uncertain system is robustly stable. □

3.2 Systems with Structured Perturbations

In this subsection, we assume the uncertainty has the following structure:

$$\mathbf{B}\Delta := \{\Delta = \text{block-diag}\{\Delta_1, \Delta_2, \dots, \Delta_N\} : \Delta \in \Delta \text{ has } \mathcal{L}_2\text{-gain} \leq 1\}. \quad (19)$$

Note that $\Delta := \text{block-diag}\{\Delta_1, \Delta_2, \dots, \Delta_N\} \in \mathbf{B}\Delta$ if and only if block Δ_i , which is a nonlinear time-varying and causal system, has \mathcal{L}_2 -gain ≤ 1 . As in the previous subsection, the following assumption is made.

Assumption 3.4 *For each $\Delta := \text{block-diag}\{\Delta_1, \Delta_2, \dots, \Delta_N\} \in \mathbf{B}\Delta$, Δ_i ($i \in \{1, 2, \dots, N\}$) has the following realization:*

$$\begin{cases} \dot{\xi}_i = f_i(\xi_i, t, y_i) \\ u_i = h_i(\xi_i, t, y_i) \end{cases}$$

which evolves on \mathbf{X}_i and has a unique asymptotically stable equilibrium at $0 \in \mathbf{X}_i$ for $y_i = 0$; in addition, there is a \mathbf{C}^1 storage function U_i such that $\dot{U}_i(\xi_i) \leq \|y_i\|^2 - \|u_i\|^2 + \psi_i(\xi_i)$ with some negative definite function $\psi_i : \mathbf{X}_i \rightarrow \mathbb{R}^+$.

To reduce the conservatism arising from the uncertainty structure, we can perform a standard manipulation as in the following diagram,

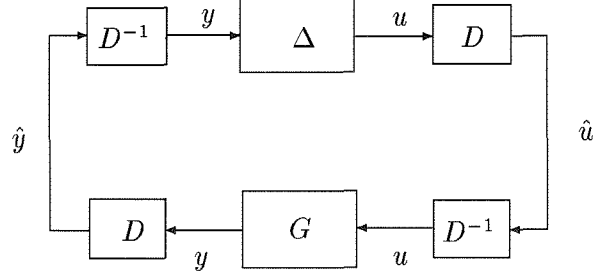

where D is some real invertible matrix. Note that the above uncertain system is the same as the one in the original diagram. Define a real valued matrix set \mathcal{D} as

$$\mathcal{D} := \{\text{block-diag}\{d_1I, d_2I, \dots, d_NI\} : d_i \in \mathbb{R}, d_i > 0\} \quad (20)$$

where each of the identity matrices is compatible with the corresponding nonlinear uncertainty Δ_i . It is noted that $D\Delta = \Delta D$ for all $D \in \mathcal{D}$ and $\Delta \in \mathbf{B}\Delta$; and for each $D \in \mathcal{D}$, $\Delta \in \mathbf{B}\Delta$ if and only if

$$D\Delta D^{-1} := \{d_1\Delta_1d_1^{-1}, d_2\Delta_2d_2^{-1}, \dots, d_N\Delta_Nd_N^{-1}\} \in \mathbf{B}\Delta.$$

In fact, the \mathcal{L}_2 -gains of Δ and $D\Delta D^{-1}$ are the same if $D \in \mathcal{D}$.

Therefore, we can view $D\Delta D^{-1}$ as a legal (transformed) uncertainty structure; it satisfies assumption 3.4 as does Δ . Thus, we may consider the scaled system DGD^{-1} which reduces the conservatism arising from the uncertainty structure (see section 7 for the motivation). We have the following theorem about the robust stability for the structured uncertain systems, which gives a natural NLMI generalization to nonlinear systems of the LMI conditions for the linear case.

Theorem 3.5 *Under assumption 3.4, the structured uncertain system with nominal plant (11) is robustly stable if there exist a positive definite \mathbf{C}^1 function $V : \mathbf{X} \rightarrow \mathbb{R}^+$ and a positive definite matrix $Q \in \mathcal{D}$ such that the following NLMI holds:*

$$\mathcal{M}(V, Q, x) := \begin{bmatrix} \frac{\partial V}{\partial x}(x)f(x) + h^T(x)Qh(x) & \frac{1}{2}\frac{\partial V}{\partial x}(x)g(x) + h^T(x)Qk(x) \\ \frac{1}{2}g^T(x)\frac{\partial V^T}{\partial x}(x) + k^T(x)Qh(x) & k^T(x)Qk(x) - Q \end{bmatrix} < 0 \quad (21)$$

for all $x \in \mathbf{X} \setminus \{0\}$.

Proof Consider (21), note that

$$\begin{aligned} & \begin{bmatrix} I & 0 \\ 0 & Q^{-1/2} \end{bmatrix} \mathcal{M}(V, Q, x) \begin{bmatrix} I & 0 \\ 0 & Q^{-1/2} \end{bmatrix} \\ &= \begin{bmatrix} \frac{\partial V}{\partial x}(x)f(x) + h^T(x)Qh(x) & \frac{1}{2}\frac{\partial V}{\partial x}(x)g(x)Q^{-1/2} + h^T(x)Qk(x)Q^{-1/2} \\ \frac{1}{2}Q^{-1/2}g^T(x)\frac{\partial V^T}{\partial x}(x) + Q^{-1/2}k^T(x)Qh(x)Q^{-1/2} & Q^{-1/2}k^T(x)Qk(x)Q^{-1/2} - I \end{bmatrix} < 0. \end{aligned}$$

Define $\hat{g}(x) = g(x)Q^{-1/2}$, $\hat{h}(x) = Q^{1/2}h(x)$ and $\hat{k}(x) = Q^{1/2}k(x)Q^{-1/2}$. Using Schur complements argument, We have that the above inequality is equivalent to the following two inequalities.

$$\hat{R}(x) := I - \hat{k}^T(x)\hat{k}(x) > 0,$$

and

$$\begin{aligned} \hat{\mathcal{H}}(V, Q, x) &:= \frac{\partial V}{\partial x}(x)f(x) + \hat{h}^T(x)\hat{h}(x) + \\ &+ \left(\frac{1}{2} \frac{\partial V}{\partial x}(x)\hat{g}(x) + \hat{h}^T(x)\hat{k}(x)\right)(I - \hat{k}^T(x)\hat{k}(x))^{-1}(x) \left(\frac{1}{2}\hat{g}^T(x) \frac{\partial V^T}{\partial x}(x) + \hat{k}^T(x)\hat{h}(x)\right) \leq 0. \end{aligned} \quad (22)$$

for all $x \in \mathbf{X} \setminus \{0\}$. Take V as defined in the statement, and define $\hat{u} = Q^{1/2}u$ and $\hat{y} = Q^{1/2}y$, then

$$\begin{aligned} \dot{V}(x) &= \frac{\partial V}{\partial x}(x)(f(x) + \hat{g}(x)\hat{u}) \\ &= \|\hat{u}(t)\|^2 - \|\hat{y}(t)\|^2 - \left\| \hat{R}^{1/2}(x)\hat{u}(t) + \hat{R}^{-1/2}(x)(\hat{k}^T(x)\hat{h}(x)x + \frac{1}{2}\hat{g}^T(x) \frac{\partial V^T}{\partial x}(x)) \right\|^2 + \hat{\mathcal{H}}(V, Q, x). \\ \dot{V}(x) &\leq \|\hat{u}(t)\|^2 - \|\hat{y}(t)\|^2 + \hat{\mathcal{H}}(V, Q, x). \end{aligned} \quad (23)$$

On the other hand, notice that $Q^{1/2} \in \mathcal{D}$; denote $Q^{1/2} = \text{block-diag}\{q_1 I, q_2 I, \dots, q_N I\}$. From the assumption 3.2, for each $\Delta \in \mathbf{B}\Delta$, there is a positive definite function $U_i : \mathbf{X}_i \rightarrow \mathbb{R}^+$ for nonlinear system $q_i \Delta_i q_i^{-1}$ for each $i \in \{1, 2, \dots, N\}$ such that

$$\dot{U}_i(\xi_i) \leq \|\hat{y}_i(t)\|^2 - \|\hat{u}_i(t)\|^2 + \psi_i(\xi_i) \quad (24)$$

for some negative definite function ψ_i on \mathbf{X}_i , where $\hat{u}_i = q_i u_i$, $\hat{y}_i = q_i y_i$ and ξ_i is the state vector of Δ_i on \mathbf{X}_i . Note that

$$\hat{u} = \begin{bmatrix} \hat{u}_1 \\ \hat{u}_2 \\ \vdots \\ \hat{u}_N \end{bmatrix}, \quad \hat{y} = \begin{bmatrix} \hat{y}_1 \\ \hat{y}_2 \\ \vdots \\ \hat{y}_N \end{bmatrix}$$

Therefore,

$$\|\hat{u}\|^2 = \sum_{i=1}^N \|\hat{u}_i\|^2, \quad \|\hat{y}\|^2 = \sum_{i=1}^N \|\hat{y}_i\|^2$$

Next, define a positive definite function W on $\mathbf{X} \times \mathbf{X}_1 \times \dots \times \mathbf{X}_N$ as

$$W(x, \xi_1, \dots, \xi_N) = V(x) + \sum_{i=1}^N U_i(\xi_i) \quad (25)$$

So from (23) and (24), it follows that

$$\begin{aligned} \dot{W}(x, \xi_1, \dots, \xi_N) &\leq \|\hat{u}(t)\|^2 - \|\hat{y}(t)\|^2 + \hat{\mathcal{H}}(V, Q, x) + \sum_{i=1}^N (\|\hat{y}_i(t)\|^2 - \|\hat{u}_i(t)\|^2 + \psi_i(\xi_i)) \\ &\leq \hat{\mathcal{H}}(P, x) + \sum_{i=1}^N \psi_i(\xi_i) \end{aligned}$$

Thence, if $\dot{W}(x, \xi_1, \dots, \xi_N) = 0$, then $\hat{\mathcal{H}}(V, Q, x) = 0$ and $\psi_i(\xi_i) = 0$ for each i ; the former condition implies $x = 0$ by (22), and the latter implies $\xi_i = 0$ by the assumption 3.4. Thus, $W : \mathbf{X} \times \mathbf{X}_1 \times \dots \times \mathbf{X}_N \rightarrow \mathbb{R}^+$ is a Lyapunov function for the feedback system, and the system is asymptotically stable. Therefore, the uncertain system is robustly stable. \square

3.3 More about Robust Stability

In the previous discussion, it is assumed that the uncertain system is well posed for each $\Delta \in \mathbf{B}\Delta$. It is known that the well-posedness is guaranteed when any one of Δ and G is strictly causal [34]. In this section, we will consider the case when G is strictly causal. Accordingly, the class of uncertainty $\mathbf{B}\Delta$ is enlarged. (Strictly causal uncertainty case can be considered analogically).

The nominal system G has the following realization

$$G : \begin{cases} \dot{x} = f(x) + g(x)u \\ y = h(x) \end{cases} \quad (26)$$

The uncertainty is structured as follows

$$\mathbf{B}\Delta := \{\Delta = \text{block-diag}\{\Delta_1, \Delta_2, \dots, \Delta_N\} : \Delta \in \Delta \text{ has } \mathcal{L}_2\text{-gain} \leq 1\}.$$

The following assumption is made.

Assumption 3.6 For each $\Delta := \{\Delta = \text{block-diag}\{\Delta_1, \Delta_2, \dots, \Delta_N\} \in \mathbf{B}\Delta, \Delta_i (i \in \{1, 2, \dots, N\})$ has the following realization:

$$\begin{cases} \dot{\xi}_i = f_i(\xi_i, t, y_i) \\ u_i = h_i(\xi_i, t, y_i) \end{cases}$$

which evolves on \mathbf{X}_i and $\dot{\xi}_i = f_i(\xi_i, t, 0)$ is asymptotically stable around $0 \in \mathbf{X}_i$; in addition, there is a \mathbf{C}^1 storage function U_i such that $\dot{U}_i(\xi_i) \leq \|y_i\|^2 - \|u_i\|^2$.

Similarly, we consider a scaled nominal system to reduce the conservatism which arises from the structural constraints of uncertainty. The scaling matrix set \mathcal{D} is defined as before

$$\mathcal{D} := \{\text{block-diag}\{d_1I, d_2I, \dots, d_NI\} : d_i \in \mathbb{R}, d_i > 0\}$$

We have the following theorem about the robust stability for this class of uncertain systems where the nominal systems are strictly causal.

Theorem 3.7 Under assumption 3.6, the uncertain system with nominal system as in (26) is robustly stable if there exist a positive definite function $V : \mathbf{X} \rightarrow \mathbb{R}^+$ and a positive definite matrix $Q \in \mathcal{D}$ such that the following NLMI holds:

$$\begin{bmatrix} \frac{\partial V}{\partial x}(x)f(x) + h^T(x)Qh(x) & \frac{1}{2} \frac{\partial V}{\partial x}(x)g(x) \\ \frac{1}{2}g^T(x) \frac{\partial V^T}{\partial x}(x) & -Q \end{bmatrix} < 0 \quad (27)$$

for all $x \in \mathbf{X} \setminus \{0\}$.

Proof (27) implies that

$$\mathcal{H}(V, Q, x) := \frac{\partial V}{\partial x}(x)f(x) + \frac{1}{4} \frac{\partial V}{\partial x}(x)g(x)Qg^T(x) \frac{\partial V}{\partial x}(x) + h^T(x)Qh(x) < 0$$

for all $x \in \mathbf{X} \setminus \{0\}$. Take $V : \mathbf{X} \rightarrow \mathbb{R}^+$ and $U_i : \mathbf{X}_i \rightarrow \mathbb{R}^+$ as given. Define a positive definite function W on $\mathbf{X} \times \mathbf{X}_1 \times \cdots \times \mathbf{X}_N$ as

$$W(x, \xi_1, \dots, \xi_N) = V(x) + \sum_{i=1}^N U_i(\xi_i) \quad (28)$$

Similar arguments used in the section 3.2 yield that

$$\dot{W}(x, \xi_1, \dots, \xi_N) \leq \mathcal{H}(V, Q, x).$$

Thence, if $\dot{W}(x, \xi_1, \dots, \xi_N) = 0$, then $\mathcal{H}(V, Q, x) = 0$; it in turn implies $x = 0$.

On the other hand $x = 0$ implies $y = 0$, so the feedback system evolves on

$$\{(x, \xi_1, \dots, \xi_N) \in \mathbf{X} \times \mathbf{X}_1 \times \cdots \times \mathbf{X}_N : x = 0, \dot{\xi}_i = f_i(\xi_i, t, 0) \forall i \in \{1, 2, \dots, N\}\}.$$

But by the assumption 3.6, $\dot{\xi}_i = f_i(\xi_i, t, 0)$ implies $\xi_i(t) \rightarrow 0$ as $t \rightarrow \infty$. By LaSalle's theorem, $W : \mathbf{X} \times \mathbf{X}_1 \times \cdots \times \mathbf{X}_N \rightarrow \mathbb{R}^+$ is a Lyapunov function for the feedback system, and the system is asymptotically stable. Therefore, the uncertain system is robustly stable. \square

4 Performance Robustness of Uncertain Systems

Consider the following feedback uncertain system which is described as a feedback system set.

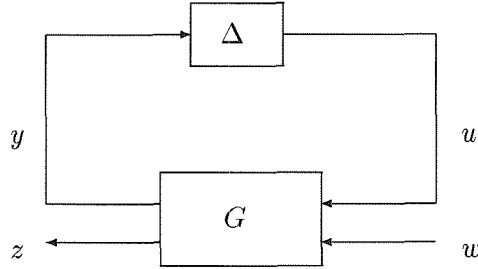

where w is some external disturbance vector, and it is assumed $w \in \mathcal{L}_2^e(\mathbb{R}^+)$; z is the regulated signal vector. The nominal plant G has the following realization

$$G : \begin{cases} \dot{x} = f(x) + g_1(x)u + g_2(x)w \\ y = h_1(x) + k_{11}(x)u + k_{12}(x)w \\ z = h_2(x) + k_{21}(x)u + k_{22}(x)w \end{cases} \quad (29)$$

and the uncertainty structure is described by the set

$$\Delta := \{\Delta = \text{block-diag}\{\Delta_1, \Delta_2, \dots, \Delta_N\} : \Delta_i \text{ is nonlinear time varying causal system for each } i\}. \quad (30)$$

Note that the unstructured uncertainty is a special case for $N = 1$. In the case of interests here, just the case where the uncertainty has finite gain is considered. In particular, it is assumed that all admissible uncertainties are in the following set.

$$\mathbf{B}\Delta := \{\Delta = \text{block-diag}\{\Delta_1, \Delta_2, \dots, \Delta_N\} : \Delta \in \mathbf{\Delta} \text{ and has } \mathcal{L}_2\text{-gain} \leq 1\} \quad (31)$$

If $\Delta := \text{block-diag}\{\Delta_1, \Delta_2, \dots, \Delta_N\} \in \mathbf{B}\Delta$, then each nonlinear system Δ_i has \mathcal{L}_2 -gain ≤ 1 .

Definition 4.1 *The uncertain system depicted above satisfies **robust performance** if for each $\Delta \in \mathbf{B}\Delta$, the corresponding feedback system is well posed and has \mathcal{L}_2 -gain ≤ 1 , i.e.,*

$$\int_0^T (\|z(t)\|^2 - \|w(t)\|^2) dt \leq 0$$

for all $T \in \mathbb{R}^+$; in addition, it is asymptotically stable around 0 for $w = 0$.

In this section, we will examine under what conditions, the uncertain system depicted above has robust performance.

4.1 Case I: General Nominal Systems

By “general”, we mean here that there is no other special structural constraint on nominal systems, except that the feedback structures of the uncertain systems are required to be well-posed for each uncertainty structure $\Delta \in \mathbf{B}\Delta$. The following assumption is made.

Assumption 4.2 *For each $\Delta \in \mathbf{B}\Delta$, Δ_i ($i \in \{1, 2, \dots, N\}$) has the following realization:*

$$\begin{cases} \dot{\xi}_i = f_i(\xi_i, t, y_i) \\ u_i = h_i(\xi_i, t, y_i) \end{cases}$$

which evolves on \mathbf{X}_i and has a unique asymptotically stable equilibrium at $0 \in \mathbf{X}_i$ for $y_i = 0$; in addition, there is a \mathbf{C}^1 storage function U_i such that $\dot{U}_i(\xi_i) \leq \|y_i\|^2 - \|u_i\|^2 + \psi_i(\xi_i)$ with some negative definite function $\psi_i : \mathbf{X}_i \rightarrow \mathbb{R}^+$.

We take the similar scaling treatment for the nominal system G to reduce the conservatism arising from the structural constraints of the uncertainty. Define the scaling matrix set \mathcal{D} as

$$\mathcal{D} := \{\text{block-diag}\{d_1 I, d_2 I, \dots, d_N I\} : \text{for each } i, d_i \in \mathbb{R}, d_i > 0\} \quad (32)$$

It is easy to see that for each $D \in \mathcal{D}$, $\Delta \in \mathbf{B}\Delta$ if and only if $D^{-1}\Delta D \in \mathbf{B}\Delta$.

We now define

$$g(x) := \begin{bmatrix} g_1(x) & g_2(x) \end{bmatrix}, h(x) := \begin{bmatrix} h_1(x) \\ h_2(x) \end{bmatrix}, k(x) := \begin{bmatrix} k_{11}(x) & k_{12}(x) \\ k_{21}(x) & k_{22}(x) \end{bmatrix},$$

we have following theorem about robust performance.

Theorem 4.3 *Under assumption 4.2, the uncertain system has robust performance if there exist a positive definite function $V : \mathbf{X} \rightarrow \mathbb{R}$ and a positive definite matrix $\hat{Q} \in \mathcal{D}$ such that the following NLMI holds:*

$$\mathcal{M}(V, Q, x) := \begin{bmatrix} \frac{\partial V}{\partial x}(x)f(x) + h^T(x)Qh(x) & \frac{1}{2}\frac{\partial V}{\partial x}(x)g(x) + h^T(x)Qk(x) \\ \frac{1}{2}g^T(x)\frac{\partial V}{\partial x}(x) + k^T(x)Qh(x) & k^T(x)Qk(x) - Q \end{bmatrix} < 0 \quad (33)$$

with $Q := \begin{bmatrix} \hat{Q} & 0 \\ 0 & I \end{bmatrix}$ for all $x \in \mathbf{X} \setminus \{0\}$.

Proof Consider (33), it is equivalent to the following inequality,

$$\begin{aligned} & \begin{bmatrix} I & 0 \\ 0 & Q^{-1/2} \end{bmatrix} \mathcal{M}(V, Q, x) \begin{bmatrix} I & 0 \\ 0 & Q^{-1/2} \end{bmatrix} \\ & = \begin{bmatrix} \frac{\partial V}{\partial x}(x)f(x) + h^T(x)Qh(x) & \frac{1}{2}\frac{\partial V}{\partial x}(x)g(x)Q^{-1/2} + h^T(x)Qk(x)Q^{-1/2} \\ \frac{1}{2}Q^{-1/2}g^T(x)\frac{\partial V^T}{\partial x}(x) + Q^{-1/2}k^T(x)Qh(x)Q^{-1/2} & Q^{-1/2}k^T(x)Qk(x)Q^{-1/2} - I \end{bmatrix} < 0, \end{aligned} \quad (34)$$

Define $\hat{g}(x) := g(x)Q^{-1/2}$, $\hat{h}(x) := Q^{1/2}h(x)$ and $\hat{k}(x) := Q^{1/2}k(x)Q^{-1/2}$. Using Schur complements argument and the above inequality is equivalent to the following two inequalities.

$$\hat{R}(x) := I - \hat{k}^T(x)\hat{k}(x) > 0,$$

and

$$\begin{aligned} \hat{\mathcal{H}}(V, Q, x) & := \frac{\partial V}{\partial x}(x)f(x) + \hat{h}^T(x)\hat{h}(x) + \\ & + \left(\frac{1}{2}\frac{\partial V}{\partial x}(x)\hat{g}(x) + \hat{h}^T(x)\hat{k}(x)\right)(I - \hat{k}^T(x)\hat{k}(x))^{-1}(x) \left(\frac{1}{2}\hat{g}^T(x)\frac{\partial V^T}{\partial x}(x) + \hat{k}^T(x)\hat{h}(x)\right) < 0. \end{aligned} \quad (35)$$

for all $x \in \mathbf{X} \setminus \{0\}$. Take V as defined in the statement; define $\hat{u} := Q^{1/2} \begin{bmatrix} u \\ w \end{bmatrix}$ and $\hat{y} = Q^{1/2} \begin{bmatrix} y \\ z \end{bmatrix}$ then

$$\dot{V}(x) \leq \|\hat{u}(t)\|^2 - \|\hat{y}(t)\|^2 + \hat{\mathcal{H}}(V, Q, x). \quad (36)$$

On the other hand, notice that $\hat{Q}^{1/2} \in \mathcal{D}$; denote $\hat{Q}^{1/2} = \text{block-diag}\{q_1 I, q_2 I, \dots, q_N I\}$. From the assumption 4.2, for all $\Delta \in \mathbf{B}\Delta$, there is a positive definite function $U_i : \mathbf{X}_i \rightarrow \mathbb{R}^+$ for nonlinear system $q_i \Delta_i q_i^{-1}$ for each $i \in \{1, 2, \dots, N\}$ such that

$$\dot{U}_i(\xi_i) \leq \|\hat{y}_i(t)\|^2 - \|\hat{u}_i(t)\|^2 + \psi_i(\xi_i) \quad (37)$$

for some negative definite function ψ_i on \mathbf{X}_i , where $\hat{u}_i = q_i u_i$, $\hat{y}_i = q_i y_i$ and ξ_i is the state vector of Δ_i on \mathbf{X}_i . Note that

$$\hat{u} = \begin{bmatrix} \hat{u}_1 \\ \hat{u}_2 \\ \vdots \\ \hat{u}_N \\ w \end{bmatrix}, \quad \hat{y} = \begin{bmatrix} \hat{y}_1 \\ \hat{y}_2 \\ \vdots \\ \hat{y}_N \\ z \end{bmatrix}$$

Therefore,

$$\|\hat{u}\|^2 = \sum_{i=1}^N \|\hat{u}_i\|^2 + \|w\|^2, \quad \|\hat{y}\|^2 = \sum_{i=1}^N \|\hat{y}_i\|^2 + \|z\|^2.$$

Next, define a positive definite function W on $\mathbf{X} \times \mathbf{X}_1 \times \dots \times \mathbf{X}_N$ as

$$W(x, \xi_1, \dots, \xi_N) = V(x) + \sum_{i=1}^N U_i(\xi_i) \quad (38)$$

So from (36) and (37), it follows that

$$\begin{aligned}
\dot{W}(x, \xi_1, \dots, \xi_N) &\leq \|\hat{u}(t)\|^2 - \|\hat{y}(t)\|^2 + \hat{\mathcal{H}}(V, Q, x) + \sum_{i=1}^N (\|\hat{y}_i(t)\|^2 - \|\hat{u}_i(t)\|^2 + \psi_i(\xi_i)) \\
&\leq \|w\|^2 - \|z\|^2 + \hat{\mathcal{H}}(V, Q, x) + \sum_{i=1}^N \psi_i(\xi_i) \\
&\leq \|w\|^2 - \|z\|^2
\end{aligned} \tag{39}$$

The latter inequality implies

$$\int_0^T (\|w\|^2 - \|z\|^2) dt \geq 0 \tag{40}$$

for all $T \in \mathbb{R}^+$, i.e., the feedback system has \mathcal{L}_2 -gain ≤ 1 .

Next, we consider the asymptotic stability for $w = 0$. In this case, (39) becomes

$$\dot{W}(x, \xi_1, \dots, \xi_N) \leq -\|z\|^2 + \hat{\mathcal{H}}(V, Q, x) + \sum_{i=1}^N \psi_i(\xi_i)$$

Thence, if $\dot{W}(x, \xi_1, \dots, \xi_N) = 0$, then $\hat{\mathcal{H}}(V, Q, x) = 0$ and $\psi_i(\xi_i) = 0$ for each i ; the former condition implies $x = 0$ by (35), and the latter implies $\xi_i = 0$ by the assumption. Therefore, $W : \mathbf{X} \times \mathbf{X}_1 \times \dots \times \mathbf{X}_N \rightarrow \mathbb{R}^+$ is a Lyapunov function for the feedback system, and the system is asymptotically stable.

Therefore, we conclude that the uncertain system satisfies robust performance. \square

Next, we further relax the condition for the last theorem to get an alternative characterization for the robust performance of the given uncertain system.

Assumption 4.4 Consider the nominal system G , define a new system

$$\begin{cases} \dot{x} = f(x) + g_1(x)u \\ z = k_2(x) + k_{21}(x)u \end{cases}$$

The solution for all possible $u(t)$ under the constraint $z(t) = 0$ satisfies $x(t) \rightarrow 0$ as $t \rightarrow \infty$.

Remark 4.5 If the system is linear, the above assumption is just a characterization of the system with stable transmission zeros.

Theorem 4.6 Under assumptions 4.4 and 4.2, the uncertain system has robust performance if there exist a positive definite \mathbf{C}^1 function $V : \mathbf{X} \rightarrow \mathbb{R}$ and a positive definite matrix $\hat{Q} \in \mathcal{D}$ such that the following NLMIs hold:

$$\begin{bmatrix} \frac{\partial V}{\partial x}(x)f(x) + h^T(x)Qh(x) & \frac{1}{2} \frac{\partial V}{\partial x}(x)g(x) + h^T(x)Qk(x) \\ \frac{1}{2} g^T(x) \frac{\partial V}{\partial x}(x) + k^T(x)Qh(x) & k^T(x)Qk(x) - Q \end{bmatrix} \leq 0 \tag{41}$$

and

$$k^T(x)Qk(x) - Q < 0 \tag{42}$$

with $g(x), h(x), k(x)$ defined previously and $Q := \begin{bmatrix} \hat{Q} & 0 \\ 0 & I \end{bmatrix}$ for all $x \in \mathbf{X}$.

Proof The proof is a combination of the one for the previous theorem and the one for theorem 2.7. We just give an outline here.

Take $V : \mathbf{X} \rightarrow \mathbb{R}^+$ as given, and $U_i : \mathbf{X}_i \rightarrow \mathbb{R}^+$ as in the proof of the last theorem. Define a positive definite function W on $\mathbf{X} \times \mathbf{X}_1 \times \cdots \times \mathbf{X}_N$ as

$$W(x, \xi_1, \dots, \xi_N) = V(x) + \sum_{i=1}^N U_i(\xi_i). \quad (43)$$

It follows that

$$\begin{aligned} \dot{W}(x, \xi_1, \dots, \xi_N) &\leq \|w\|^2 - \|z\|^2 + \sum_{i=1}^N \psi_i(\xi_i) \\ &\leq \|w\|^2 - \|z\|^2 \end{aligned} \quad (44)$$

The latter inequality implies

$$\int_0^T (\|w\|^2 - \|z\|^2) dt \geq 0 \quad (45)$$

for all $T \in \mathbb{R}^+$, i.e. the feedback system has \mathcal{L}_2 -gain ≤ 1 .

Next, we consider the asymptotic stability for $w = 0$. In this case, (44) becomes

$$\dot{W}(x, \xi_1, \dots, \xi_N) \leq -\|z\|^2 + \sum_{i=1}^N \psi_i(\xi_i)$$

Thence, if $\dot{W}(x, \xi_1, \dots, \xi_N) = 0$, then $z = h_2(x)x + k_{21}(x)u = 0$ and $\psi_i(\xi_i) = 0$ for each i ; the former condition implies $x(t) \rightarrow 0$ as $t \rightarrow \infty$ by assumption 4.4, and the latter implies $\xi_i = 0$ by assumption 4.2. By LaSalle's theorem, $W : \mathbf{X} \times \mathbf{X}_1 \times \cdots \times \mathbf{X}_N \rightarrow \mathbb{R}^+$ is a Lyapunov function for the given closed loop system, and the system is asymptotically stable.

Therefore, we conclude that the uncertain system has robust performance. \square

4.2 Case II: Strictly Causal Nominal Systems

In this subsection, we consider the case where the nominal system G is strictly causal with respect to the input u . In this case, the well-posedness of the feedback system is guaranteed for each $\Delta \in \mathbf{B}\Delta$. Accordingly, the uncertainty class $\mathbf{B}\Delta$ is enlarged.

The nominal system G has the following realization.

$$G : \begin{cases} \dot{x} = f(x) + g_1(x)u + g_2(x)w \\ y = h_1(x) + k_{12}(x)w \\ z = h_2(x) + k_{21}(x)u + k_{22}(x)w \end{cases} \quad (46)$$

The uncertainty structure is described by the set

$$\mathbf{B}\Delta := \{\Delta = \text{block-diag}\{\Delta_1, \Delta_2, \dots, \Delta_N\} : \Delta \in \Delta \text{ and has } \mathcal{L}_2\text{-gain} \leq 1\} \quad (47)$$

Assumption 4.7 For all $\Delta \in \mathbf{B}\Delta$, Δ_i ($i \in \{1, 2, \dots, N\}$) has the following realization:

$$\begin{cases} \dot{\xi}_i = f_i(\xi_i, t, y_i) \\ u_i = h_i(\xi_i, t, y_i) \end{cases}$$

which evolves on \mathbf{X}_i and has a unique asymptotically stable equilibrium at $0 \in \mathbf{X}_i$ for $y_i = 0$; in addition, there is a \mathbf{C}^1 storage function U_i such that $\dot{U}_i(\xi_i) \leq \|y_i\|^2 - \|u_i\|^2$.

The scaling matrix set \mathcal{D} is defined as before

$$\mathcal{D} := \{\text{block-diag}\{d_1 I, d_2 I, \dots, d_N I\} : \text{for each } i, d_i \in \mathbb{R}, d_i > 0\}$$

It is easy to see that for each $D \in \mathcal{D}$, $\Delta \in \mathbf{B}\Delta$ if and only if $D^{-1}\Delta D \in \mathbf{B}\Delta$.

We now define

$$g(x) := \begin{bmatrix} g_1(x) & g_2(x) \end{bmatrix}, h(x) := \begin{bmatrix} h_1(x) \\ h_2(x) \end{bmatrix}, k(x) := \begin{bmatrix} 0 & k_{12}(x) \\ k_{21}(x) & k_{22}(x) \end{bmatrix},$$

we have the following result about robust performance analysis.

Theorem 4.8 Under assumption 4.7, the uncertain system with nominal plant (46) has robust performance if there exist a positive definite \mathbf{C}^1 function $V : \mathbf{X} \rightarrow \mathbb{R}$ and a positive definite matrix $\hat{Q} \in \mathcal{D}$ such that the following NLMI holds:

$$\begin{bmatrix} \frac{\partial V}{\partial x}(x)f(x) + h^T(x)Qh(x) & \frac{1}{2}\frac{\partial V}{\partial x}(x)g(x) + h^T(x)Qk(x) \\ \frac{1}{2}g^T(x)\frac{\partial V^T}{\partial x}(x) + k^T(x)Qh(x) & k^T(x)Qk(x) - Q \end{bmatrix} < 0 \quad (48)$$

with $Q = \begin{bmatrix} \hat{Q} & 0 \\ 0 & I \end{bmatrix}$ for all $x \in \mathbf{X} \setminus \{0\}$.

Proof Consider (48), it is equivalent to the following inequalities

$$\hat{R}(x) := I - \hat{k}^T(x)\hat{k}(x) > 0,$$

and

$$\begin{aligned} \hat{\mathcal{H}}(V, Q, x) := & \frac{\partial V}{\partial x}(x)f(x) + \hat{h}^T(x)\hat{h}(x) + \\ & + \left(\frac{1}{2}\frac{\partial V}{\partial x}(x)\hat{g}(x) + \hat{h}^T(x)\hat{k}(x)\right)(I - \hat{k}^T(x)\hat{k}(x))^{-1}(x) \left(\frac{1}{2}\hat{g}^T(x)\frac{\partial V^T}{\partial x}(x) + \hat{k}^T(x)\hat{h}(x)\right) < 0. \end{aligned} \quad (49)$$

for all $x \in \mathbf{X} \setminus \{0\}$.

Take $V : \mathbf{X} \rightarrow \mathbb{R}^+$ $U_i : \mathbf{X}_i \rightarrow \mathbb{R}^+$ as given. Define a positive definite function W on $\mathbf{X} \times \mathbf{X}_1 \times \dots \times \mathbf{X}_N$ as

$$W(x, \xi_1, \dots, \xi_N) = V(x) + \sum_{i=1}^N U_i(\xi_i) \quad (50)$$

Similar arguments in the previous section yield that

$$\begin{aligned}\dot{W}(x, \xi_1, \dots, \xi_N) &\leq \|w\|^2 - \|z\|^2 + \hat{\mathcal{H}}(V, Q, x) \\ &\leq \|w\|^2 - \|z\|^2\end{aligned}\tag{51}$$

The latter inequality implies

$$\int_0^T (\|w\|^2 - \|z\|^2) dt \geq 0\tag{52}$$

for all $T \in \mathbb{R}^+$, i.e., the feedback system has \mathcal{L}_2 -gain ≤ 1 .

Next, we consider the asymptotic stability for $w = 0$. In this case, (51) becomes

$$\dot{W}(x, \xi_1, \dots, \xi_N) \leq -\|z\|^2 + \hat{\mathcal{H}}(V, Q, x).$$

Thence, if $\dot{W}(x, \xi_1, \dots, \xi_N) = 0$, then $\hat{\mathcal{H}}(V, Q, x) = 0$, it in turn implies $x = 0$ by (49). But $x = 0$ implies $y = 0$, therefore $\xi_i(t) \rightarrow 0$ as $t \rightarrow \infty$, for $\xi_i = f_i(\xi_i, t, 0)$. By LaSalle's theorem, $W : \mathbf{X} \times \mathbf{X}_1 \times \dots \times \mathbf{X}_N \rightarrow \mathbb{R}^+$ is a Lyapunov function for the given closed loop system, and the system is asymptotically stable.

Therefore, we conclude that the uncertain system is of robust performance. \square

Next, we further relax the condition for the last theorem to get an alternative characterization for the robust performance of the depicted uncertain system with nominal system (46).

Assumption 4.9 Consider the nominal system G , define a new system

$$\begin{cases} \dot{x} = f(x) + g_1(x)u \\ z = h_2(x) + k_{21}(x)u \end{cases}$$

The solution for all possible $u(t)$ under the constraint $z(t) = 0$ satisfies $x(t) = 0$ for all $t \in \mathbb{R}^+$.

It is noted that in the linear case, the above assumption corresponds to the condition that the system has no transmission zero.

Theorem 4.10 Under assumptions 4.9 and 4.7, the uncertain system has robust performance if there exist a positive definite \mathbf{C}^1 function $V : \mathbf{X} \rightarrow \mathbb{R}$ and a positive definite matrix $\hat{Q} \in \mathcal{D}$ such that the following NLMIs hold:

$$\begin{bmatrix} \frac{\partial V}{\partial x}(x)f(x) + h^T(x)Qh(x) & \frac{1}{2}\frac{\partial V}{\partial x}(x)g(x) + h^T(x)Qk(x) \\ \frac{1}{2}g^T(x)\frac{\partial V}{\partial x}(x) + k^T(x)Qh(x) & k^T(x)Qk(x) - Q \end{bmatrix} \leq 0\tag{53}$$

$$k^T(x)Qk(x) - Q < 0\tag{54}$$

with $B(x), C(x), D(x)$ defined previously and $Q := \begin{bmatrix} \hat{Q} & 0 \\ 0 & I \end{bmatrix}$ for all $x \in \mathbf{X}$.

Proof The proof is a combination of the one for previous theorem and the one for theorem 2.7. We just give an outline here.

Take $V : \mathbf{X} \rightarrow \mathbb{R}^+$ as given, and $U_i : \mathbf{X}_i \rightarrow \mathbb{R}^+$ as in the proof of the last theorem. Define a positive definite function W on $\mathbf{X} \times \mathbf{X}_1 \times \cdots \times \mathbf{X}_N$ as

$$W(x, \xi_1, \cdots, \xi_N) = V(x) + \sum_{i=1}^N U_i(\xi_i) \quad (55)$$

It follows that

$$\dot{W}(x, \xi_1, \cdots, \xi_N) \leq \|w\|^2 - \|z\|^2$$

The latter inequality implies

$$\int_0^T (\|w\|^2 - \|z\|^2) dt \geq 0 \quad (56)$$

for all $T \in \mathbb{R}^+$, i.e., the feedback system has \mathcal{L}_2 -gain ≤ 1 .

Next, we consider the asymptotic stability for $w = 0$. In this case,

$$\dot{W}(x, \xi_1, \cdots, \xi_N) \leq -\|z\|^2$$

Thence, if $\dot{W}(x, \xi_1, \cdots, \xi_N) = 0$, then $z = h_2(x) + k_{21}(x)u = 0$ which implies $x(t) = 0$ by assumption 4.9. But $x = 0$ implies $y = 0$, therefore $\xi_i(t) \rightarrow 0$ as $t \rightarrow \infty$, for $\dot{\xi}_i = f_i(\xi_i, t, 0)$. By LaSalle's theorem, $W : \mathbf{X} \times \mathbf{X}_1 \times \cdots \times \mathbf{X}_N \rightarrow \mathbb{R}^+$ is a Lyapunov function for the given closed loop system, and the system is asymptotically stable.

Therefore, the uncertain system satisfies robust performance. \square

5 On Robustness Synthesis

In the robustness analysis results in the last two sections, the robustness conditions of uncertain systems are essentially the small gain conditions for (scaled) nominal systems modulo some appropriate stabilizing conditions. So the robustness synthesis can be pursued by combining the robustness analysis results in the last two sections with the treatments of \mathcal{H}_∞ -control synthesis (see for example [31, 3, 18]). We just take the performances robustness synthesis problem as an example, the other problems can be done similarly. Technically, we closely follow the treatments in [18, 17], so we just take the state feedback case as an example. The output feedback case can be done similarly by just modifying the treatments in [18, 17]. It is noticed that the robust stabilization with unstructured uncertainty is also considered in [32].

Consider the following feedback uncertain system which is described as a feedback system set.

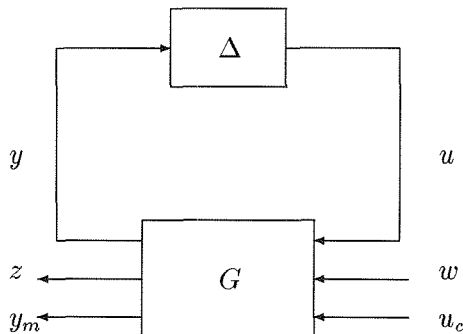

where $w \in \mathcal{L}_2^e(\mathbb{R}^+)$ is some external disturbance vector, z is the regulated signal vector, y_m is the measured output vector, and based on which the control input vector u_c is produced. The nominal plant G has the following realization

$$G : \begin{cases} \dot{x} = f(x) + g_1(x)u + g_2(x)w + g_3(x)u_c \\ y = h_1(x) + k_{11}(x)u + k_{12}(x)w + k_{13}(x)u_c \\ z = h_2(x) + k_{21}(x)u + k_{22}(x)w + k_{23}(x)u_c \\ y_m = h_3(x) + k_{31}(x)u + k_{32}(x)w + k_{33}(x)u_c \end{cases} \quad (57)$$

where $f, g_i, h_j, k_{ij} \in \mathbf{C}^0$, and $f(0) = 0, h_j(0) = 0$, for $i, j = 1, 2, 3$. In this section, the state vector of the nominal system is directly measured, i.e., $y_m = x$; the uncertainty structure is described by the set

$$\mathbf{\Delta} := \{\Delta = \text{block-diag}\{\Delta_1, \Delta_2, \dots, \Delta_N\} : \Delta_i \text{ is nonlinear time varying causal system for each } i\}.$$

And the admissible uncertainties are in the following set.

$$\mathbf{B}\mathbf{\Delta} := \{\Delta = \text{block-diag}\{\Delta_1, \Delta_2, \dots, \Delta_N\} : \Delta \in \mathbf{\Delta} \text{ and has } \mathcal{L}_2\text{-gain} \leq 1\} \quad (58)$$

The performance robustness synthesis problem by state feedback is defined as follows.

Definition 5.1 (State Feedback Synthesis Problem) *Find a state feedback law $u_c = K(x)$ with $K \in \mathbf{C}^0$ and $K(0) = 0$ for the uncertain system depicted above such that the closed loop uncertain system satisfies robust performance.*

If $u_c = K(x)$ is a state feedback law, then the closed loop uncertain system is as follows.

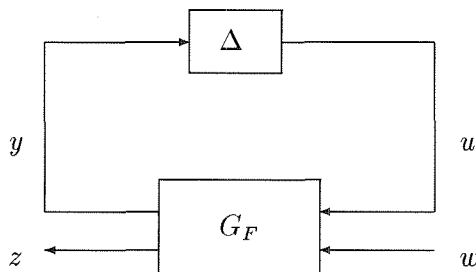

with

$$G_F : \begin{cases} \dot{x} = (f(x) + g_3(x)K(x)) + g_1(x)u + g_2(x)w \\ y = (h_1(x) + k_{13}(x)K(x)) + k_{11}(x)u + k_{12}(x)w \\ z = (h_2(x) + k_{23}(x)K(x)) + k_{21}(x)u + k_{22}(x)w \end{cases}$$

Define the scaling matrix set \mathcal{D} as

$$\mathcal{D} := \{\text{block-diag}\{d_1I, d_2I, \dots, d_NI\} : \text{for each } i, d_i \in \mathbb{R}, d_i > 0\} \quad (59)$$

It is easy to see that for each $D \in \mathcal{D}$, $D\Delta = \Delta D$ for $\Delta \in \mathbf{\Delta}$; and $\Delta \in \mathbf{B}\mathbf{\Delta}$ if and only if $D^{-1}\Delta D \in \mathbf{B}\mathbf{\Delta}$.

Next, we consider two cases about robustness synthesis by state feedback.

5.1 State Feedback Solutions

Consider the uncertain system with the nominal plant as (57). Define

$$g(x) := \begin{bmatrix} g_1(x) & g_2(x) \end{bmatrix}, h(x) := \begin{bmatrix} h_1(x) \\ h_2(x) \end{bmatrix},$$

$$k_1(x) := \begin{bmatrix} k_{11}(x) & k_{12}(x) \\ k_{21}(x) & k_{22}(x) \end{bmatrix}, k_2(x) := \begin{bmatrix} k_{13}(x) \\ k_{23}(x) \end{bmatrix}.$$

The following structural constraints are imposed.

Assumption 5.2 $k_1(x) = 0$, and $k_2^T(x) \begin{bmatrix} h(x) & k_2(x) \end{bmatrix} = \begin{bmatrix} 0 & R_0(x) \end{bmatrix}$ where $R_0(x) > 0$ for all $x \in \mathbf{X}$.

It is noted that if $\Delta := \text{block-diag}\{\Delta_1, \Delta_2, \dots, \Delta_N\} \in \mathbf{B}\Delta$, then each nonlinear system Δ_i has \mathcal{L}_2 -gain ≤ 1 . Furthermore, we have the following stronger assumption.

Assumption 5.3 For each $\Delta \in \mathbf{B}\Delta$, Δ_i ($i \in \{1, 2, \dots, N\}$) has the following realization:

$$\begin{cases} \dot{\xi}_i = f_i(\xi_i, t, y_i) \\ u_i = h_i(\xi_i, t, y_i) \end{cases}$$

which evolves on \mathbf{X}_i and has a unique asymptotically stable equilibrium at $0 \in \mathbf{X}_i$ for $y_i = 0$; in addition, there is a \mathbf{C}^1 storage function U_i such that $\dot{U}_i(\xi_i) \leq \|y_i\|^2 - \|u_i\|^2$.

We first have the following lemma.

Lemma 5.4 Consider the system defined in (57) with the structural assumption 5.2. The following two statements are equivalent.

(i) There exist a \mathbf{C}^0 vector-valued function $K(x)$ on \mathbf{X} , a \mathbf{C}^1 positive definite function $V : \mathbf{X} \rightarrow \mathbb{R}^+$, and a positive definite matrix $\hat{Q} \in \mathcal{D}$ such that the following NLMI holds,

$$\begin{bmatrix} \frac{\partial V}{\partial x}(x)(f(x) + g_3(x)K(x)) + (h(x) + k_2(x)K(x))^T \hat{Q} (h(x) + k_2(x)K(x)) & \frac{1}{2} \frac{\partial V}{\partial x}(x)g(x) \\ \frac{1}{2} g^T(x) \frac{\partial V^T}{\partial x}(x) & -\hat{Q} \end{bmatrix} < 0$$

for all $x \in \mathbf{X} \setminus \{0\}$.

(ii) There exist a \mathbf{C}^1 positive definite function $V : \mathbf{X} \rightarrow \mathbb{R}^+$ and a positive definite matrix $\hat{Q} \in \mathcal{D}$ such that the following NLMI holds,

$$\frac{\partial V}{\partial x}(x)f(x) + \frac{1}{4} \frac{\partial V}{\partial x}(x)(g(x)Q^{-1}g^T(x) - g_3(x)R_0^{-1}(x)g_3^T(x)) \frac{\partial V^T}{\partial x}(x) + h^T(x)Qh(x) < 0.$$

for all $x \in \mathbf{X} \setminus \{0\}$.

Moreover, if (ii) is true, then a state feedback function $K(x)$ makes (i) true is as follows.

$$K(x) = -\frac{1}{2} R_0^{-1}(x)g_3^T(x) \frac{\partial V}{\partial x}(x).$$

Proof Note that the NLMI in statement (i) is equivalent to the following Hamilton-Jacobi inequality,

$$\begin{aligned} & \frac{\partial V}{\partial x}(x)(f(x) + g_3(x)K(x)) + \frac{1}{4} \frac{\partial V}{\partial x}(x)g(x)Q^{-1}g^T(x) \frac{\partial V^T}{\partial x}(x) + \\ & + (h(x) + k_2(x)K(x))^T Q (h(x) + k_2(x)K(x)) < 0 \end{aligned}$$

for all $x \in \mathbf{X} \setminus \{0\}$. By the same arguments as in [17, Theorem 4.1], the conclusion follows. \square

The main result in this subsection is stated as follows.

Theorem 5.5 *Consider the uncertain system with nominal plant as (57). Under assumptions 5.3 and 5.2, the state feedback robust performance synthesis problem has a solution if there exist a positive definite \mathbf{C}^1 positive definite function $V : \mathbf{X} \rightarrow \mathbb{R}^+$ and a positive definite matrix $\hat{Q} \in \mathcal{D}$ such that the following NLMI holds,*

$$\frac{\partial V}{\partial x}(x)f(x) + \frac{1}{4} \frac{\partial V}{\partial x}(x)(g(x)Q^{-1}g^T(x) - g_3(x)R_0^{-1}(x)g_3^T(x)) \frac{\partial V^T}{\partial x}(x) + h^T(x)Qh(x) < 0. \quad (60)$$

for all $x \in \mathbf{X} \setminus \{0\}$. Moreover, if $(V(x), Q)$ is such a pair of solutions, then a state feedback function $K(x)$ makes the closed loop system has a robust performance is $K(x) = -\frac{1}{2}R_0^{-1}(x)g_3^T(x) \frac{\partial V}{\partial x}(x)$.

Proof Let $(V(x), Q)$ be as in the theorem. By the preceding lemma, there exist a \mathbf{C}^0 matrix valued function $K(x)$ on \mathbf{X} defined as $K(x) = -\frac{1}{2}R_0^{-1}(x)g_3^T(x) \frac{\partial V}{\partial x}(x)$, such that

$$\left[\begin{array}{c} \frac{\partial V}{\partial x}(x)(f(x) + g_3(x)K(x)) + (h(x) + k_2(x)K(x))^T Q (h(x) + k_2(x)K(x)) \quad \frac{1}{2} \frac{\partial V}{\partial x}(x)g(x) \\ \frac{1}{2}g^T(x) \frac{\partial V^T}{\partial x}(x) \quad -Q \end{array} \right] < 0 \quad (61)$$

for all $x \in \mathbf{X} \setminus \{0\}$. On the other hand, take $u_c = K(x)$ as a state feedback law, so the closed loop nominal system is as follows.

$$G_F : \begin{cases} \dot{x} = (f(x) + g_3(x)K(x)) + g_1(x)u + g_2(x)w \\ y = (h_1(x) + k_{13}(x)K(x)) \\ z = (h_2(x) + k_{23}(x)K(x)) \end{cases}$$

By theorem 4.8, the closed loop uncertain system satisfies robust performance. \square

Note that the above characterization is not convex in general. In the next subsection, we will give a convex characterization which have some computationally appealing property.

5.2 A Convex Characterization for State Feedback Solutions

In this section, in stead of the nominal plant (57), the following nominal plant is examined.

$$G : \begin{cases} \dot{x} = A(x)x + B_1(x)u + B_2(x)w + B_3(x)u_c \\ y = C_1(x)x + D_{11}(x)u + D_{12}(x)w + D_{13}(x)u_c \\ z = C_2(x)x + D_{21}(x)u + D_{22}(x)w + D_{23}(x)u_c \\ y_m = x \end{cases} \quad (62)$$

where A, B_i, C_j, D_{ij} are \mathbf{C}^0 matrix-valued functions.

We now define

$$B(x) := \begin{bmatrix} B_1(x) & B_2(x) \end{bmatrix}, C(x) := \begin{bmatrix} C_1(x) \\ C_2(x) \end{bmatrix}, D(x) := \begin{bmatrix} D_{11}(x) & D_{12}(x) \\ D_{21}(x) & D_{22}(x) \end{bmatrix},$$

and

$$\tilde{B}(x) := \begin{bmatrix} B_3^T(x) & D_{13}^T(x) & D_{23}^T(x) \end{bmatrix},$$

and let $\mathcal{N}(\tilde{B}(x))$ be the distribution on \mathbf{X} which annihilates all of the row vectors of $\tilde{B}(x)$.

It is noted that if $\Delta := \text{block-diag}\{\Delta_1, \Delta_2, \dots, \Delta_N\} \in \mathbf{B}\Delta$, then each nonlinear system Δ_i has \mathcal{L}_2 -gain ≤ 1 . Furthermore, we have the following stronger assumption on the uncertainty.

Assumption 5.6 For each $\Delta \in \mathbf{B}\Delta$, Δ_i ($i \in \{1, 2, \dots, N\}$) has the following realization:

$$\begin{cases} \dot{\xi}_i = f_i(\xi_i, t, y_i) \\ u_i = h_i(\xi_i, t, y_i) \end{cases}$$

which evolves on \mathbf{X}_i and has a unique asymptotically stable equilibrium at $0 \in \mathbf{X}_i$ for $y_i = 0$; in addition, there is a \mathbf{C}^1 storage function U_i such that $\dot{U}_i(\xi_i) \leq \|y_i\|^2 - \|u_i\|^2 + \psi_i(\xi_i)$ with some negative definite function $\psi_i : \mathbf{X}_i \rightarrow \mathbb{R}^+$.

We first have the following lemma.

Lemma 5.7 The following two statements are equivalent.

(i) There exist a \mathbf{C}^0 matrix valued function $F(x)$, a positive definite matrix-valued function $P : \mathbf{X} \rightarrow \mathbb{R}^{n \times n}$, and a positive definite matrix $\hat{Q} \in \mathcal{D}$ such that the following NLMI holds:

$$\begin{bmatrix} A_F^T(x)P(x) + P(x)A_F(x) + C_F^T(x)QC_F(x) & P(x)B(x) + C_F^T(x)QD(x) \\ B^T(x)P(x) + D^T(x)QC_F(x) & D^T(x)QD(x) - Q \end{bmatrix} < 0 \quad (63)$$

with $Q := \begin{bmatrix} \hat{Q} & 0 \\ 0 & I \end{bmatrix}$ for all $x \in \mathbf{X}$, where

$$A_F(x) = A(x) + B_3(x)F(x), \quad C_F(x) = \begin{bmatrix} C_1(x) + D_{13}(x)F(x) \\ C_2(x) + D_{23}(x)F(x) \end{bmatrix}.$$

(ii) There exist a positive definite matrix-valued function $X : \mathbf{X} \rightarrow \mathbb{R}^{n \times n}$ and a positive definite matrix $\hat{Y} \in \mathcal{D}$ such that the following NLMI holds:

$$B_\perp^T(x) \begin{bmatrix} A(x)X(x) + X(x)A^T(x) + B^T(x)YB(x) & X(x)C^T(x) + B(x)YD^T(x) \\ C(x)X(x) + D(x)YB^T(x) & D(x)YD^T(x) - Y \end{bmatrix} B_\perp(x) < 0 \quad (64)$$

with $Y := \begin{bmatrix} \hat{Y} & 0 \\ 0 & I \end{bmatrix}$, and $B_\perp(x)$ is a \mathbf{C}^0 matrix-valued function on \mathbf{X} such that $\text{span}(B_\perp(x)) = \mathcal{N}(\tilde{B}(x))$ for all $x \in \mathbf{X}$.

Moreover, If any one of the above statements holds, then the solutions of the other NLMI can be chosen such that $P(x) = X^{-1}(x)$ and $Q = Y^{-1}$.

Proof Use the similar argument in [18, Section 4]. \square

It is noted that the NLMI (64) is affine in unknown $P(x)$ and Q . We have following theorem which convexly characterizes robust performance synthesis by state feedback.

Theorem 5.8 *Consider the uncertain system with nominal plant defined as (62). Under assumption 5.6, the state feedback robust performance synthesis problem has a solution if there exist a positive definite matrix-valued function $X : \mathbf{X} \rightarrow \mathbb{R}^{n \times n}$ and a positive definite matrix $\hat{Y} \in \mathcal{D}$ such that the NLMI (64) holds for all $x \in \mathbf{X}$, and $\frac{\partial V}{\partial x}(x) = 2x^T X^{-1}(x)$ for some \mathbf{C}^1 function V on \mathbf{X} with $V(0) = 0$.*

Proof Let $(X(x), Y)$ be as in the theorem. By the preceding lemma, there exist a \mathbf{C}^0 matrix valued function $F(x)$ on \mathbf{X} , such that

$$\begin{bmatrix} A_F^T(x)X^{-1}(x) + X^{-1}(x)A_F(x) + C_F^T(x)Y^{-1}C_F(x) & X^{-1}(x)B(x) + C_F^T(x)Y^{-1}D(x) \\ B^T(x)X^{-1}(x) + D^T(x)Y^{-1}C_F(x) & D^T(x)Y^{-1}D(x) - Y^{-1} \end{bmatrix} < 0 \quad (65)$$

On the other hand, take $u_c = F(x)x$ as a state feedback law, so the closed loop nominal system is as follows.

$$G_F : \begin{cases} \dot{x} = (A(x) + B_3(x)F(x))x + B_1(x)u + B_2(x)w \\ y = (C_1(x) + D_{13}(x)F(x))x + D_{11}(x)u + D_{12}(x)w \\ z = (C_2(x) + D_{23}(x)F(x))x + D_{21}(x)u + D_{22}(x)w \end{cases}$$

We now claim the closed loop uncertain system satisfies robust performance. In fact, take $(P(x), Q) = (X^{-1}(x), Y^{-1})$. By the remarks in section 2.3, (65) implies that

$$\begin{bmatrix} x^T(A_F^T(x)P(x) + P(x)A_F(x) + C_F^T(x)QC_F(x))x & x^T(P(x)B(x) + C_F^T(x)QD(x)) \\ (B^T(x)P(x) + D^T(x)QC_F(x))x & D^T(x)QD(x) - Q \end{bmatrix} < 0$$

The conclusion therefore follows from theorem 4.3. \square

6 Computational Issues

We address computational issues for robustness analysis and synthesis in this section. From the development of the theory, it is noted that the computation about robustness analysis and synthesis involves solving some NLMIs. To be more concrete, we take the following NLMI with respect to $(V(x), Q)$ (i.e. (21) or (33)) as an example,

$$\mathcal{M}(V, Q, x) := \begin{bmatrix} \frac{\partial V}{\partial x}(x)f(x) + h^T(x)Qh(x) & \frac{1}{2}\frac{\partial V}{\partial x}(x)g(x) + h^T(x)Qk(x) \\ \frac{1}{2}g^T(x)\frac{\partial V}{\partial x}(x) + k^T(x)Qh(x) & k^T(x)Qk(x) - Q \end{bmatrix} \leq 0$$

for all $x \in \mathbf{X}$. The computation procedure is therefore divided into the following two steps,

- Find $(p(x), Q)$ for some \mathbf{C}^0 vector valued function $p : \mathbf{X} \rightarrow \mathbb{R}^n$ with $p(0) = 0$ and positive definite matrix such that

$$\begin{bmatrix} 2p^T(x)f(x) + h^T(x)Qh(x) & p^T(x)g(x) + h^T(x)Qk(x) \\ g^T(x)p(x) + k^T(x)Qh(x) & k^T(x)Qk(x) - Q \end{bmatrix} \leq 0; \quad (66)$$

- Check if there is a Lyapunov function $V : \mathbf{X} \rightarrow \mathbb{R}^+$ such that $\frac{\partial V}{\partial x}(x) = 2p^T(x)$ for $x \in \mathbf{X}$.

Next, we pursue these two issues. The reader is also referred to [18] for a detailed discussion about a special case. The technique used here is the same as that in [18].

6.1 Solutions of NLMIs

We first consider the solution about (66). As discussed in section 2.3, if we assume $f(x) = A(x)x, g(x) = B(x), h(x) = C(x)x, k(x) = D(x)$, and $p(x) = P(x)x$ in (66), then (66) is implied by the following NLMI (which is a more conservative characterization about robustness),

$$\mathcal{M}(P, Q, x) := \begin{bmatrix} A^T(x)P(x) + P^T(x)A(x) + C^T(x)QC(x) & P^T(x)B(x) + C^T(x)QD(x) \\ B^T(x)P(x) + D^T(x)QC(x) & D^T(x)QD(x) - Q \end{bmatrix} \leq 0. \quad (67)$$

In this subsection, we need to find a \mathbf{C}^0 matrix-valued function $P : \mathbf{X} \rightarrow \mathbb{R}^{n \times n}$ and a positive definite matrix Q such that $\mathcal{M}(P, Q, x) \leq 0$. In other word, if $(P(x), Q)$ is a solution to (67), then $(P(x)x, Q)$ is a solution to (66).

Under some regularity conditions, the existence of continuous and positive definite solutions to NLMIs is also justified. Given a matrix valued function $S : \mathbf{X} \rightarrow \mathbb{R}^{n \times n}$ with $S(x) \geq 0$ for all $x \in \mathbf{X}$. Let $R(x) := Q - D^T(x)QD(x) > 0$, define a state-dependent Hamiltonian $H : \mathbf{X} \rightarrow \mathbb{R}^{2n \times 2n}$ as

$$H(x) := \begin{bmatrix} A(x) & 0 \\ -C^T(x)QC(x) - S(x) & -A^T(x) \end{bmatrix} + \begin{bmatrix} B(x) \\ -C^T(x)QD(x) \end{bmatrix} R^{-1}(x) \begin{bmatrix} D^T(x)QC(x) & B^T(x) \end{bmatrix}. \quad (68)$$

The following result is essentially from [13, lemma 2.4].

Theorem 6.1 $\mathcal{M}(P, Q, x) \leq 0$ has non-negative definite solutions $P(x) \geq 0$ and $Q > 0$ if and only if the state-dependent Hamiltonian $H : \mathbf{X} \rightarrow \mathbb{R}^{2n \times 2n}$ defined in (68) for some matrix-valued function $S : \mathbf{X} \rightarrow \mathbb{R}^{n \times n}$ with $S(x) \geq 0$ for all $x \in \mathbf{X}$ is in $\text{dom}(\text{Ric})$, i.e. $H(x) \in \text{dom}(\text{Ric})$ for each $x \in \mathbf{X}$. Moreover, $P(x) := \text{Ric}(H(x)) \geq 0$ is such a solution with $Q > 0$ as given. In addition, if for each $x \in \mathbf{X}$,

$$\bigcap_{i=0}^{n-1} \ker(\tilde{C}(x)A^i(x)) = \emptyset, \quad \tilde{C}(x) = \begin{bmatrix} Q^{1/2}C(x) \\ S^{1/2}(x) \end{bmatrix},$$

this solution is positive definite, i.e., $\text{Ric}(H(x)) > 0$.

The above theorem implies that under the condition $H(x) \in \text{dom}(\text{Ric})$ for each $x \in \mathbf{X}$, the NLMI $\mathcal{M}(P, Q, x) \leq 0$ has non-negative definite solutions $P(x) \geq 0$ and $Q > 0$. The following theorem further shows that such solutions can be chosen to be continuous in the case of interest in this paper.

Theorem 6.2 Suppose the matrix inequality $\mathcal{M}(P, Q, x) < 0$ has a positive definite solution $P(x)$ for each $x \in \mathbf{X}$ and $Q > 0$, then there exists a \mathbf{C}^0 matrix-valued function $P : \mathbf{X} \rightarrow \mathbb{R}^{n \times n}$ with $P(x) = P^T(x) \geq 0$, such that $\mathcal{M}(P(x), Q, x) < 0$ for all $x \in \mathbf{X}$.

Proof Consider the NLMI:

$$\mathcal{M}(P, Q, x) \leq 0.$$

with $x \in \mathbf{X}$, where $\mathcal{M} : \mathbb{R}^{n \times n} \times \mathbb{R}^{p \times p} \times \mathbf{X} \rightarrow \mathbf{S}(\mathbb{R}^{(n+p) \times (n+p)})$ is continuous and satisfies

$$\mathcal{M}\left(\sum_{k=1}^N \alpha_k P_k, \sum_{k=1}^N \alpha_k Q_k, x\right) = \sum_{k=1}^N \alpha_k \mathcal{M}(P_k, Q_k, x) \quad (69)$$

for all $\alpha_k \geq 0$ with $\sum_{k=1}^N \alpha_k = 1$.

By assumption, there exists a positive definite matrix $Q \in \mathbb{R}^{p \times p}$, for each $x \in \mathbf{X}$, there is a positive definite $P_x \in \mathbb{R}^{n \times n}$ such that

$$\mathcal{M}(P_x, Q, x) < 0.$$

By continuity of M with respect to x , there is a $r_x > 0$ such that for all $x_0 \in \mathbf{N}(x) := \{x_0 : \|x_0 - x\| < r_x\}$,

$$\mathcal{M}(P_x, Q, x_0) < 0. \quad (70)$$

On the other hand, $\{\mathbf{N}(x)\}_{x \in \mathbf{X}}$ is an open covering of X , i.e.,

$$X \subset \bigcup_{x \in \mathbf{X}} \mathbf{N}(x) \quad (71)$$

Since the space \mathbb{R}^n is *paracompact*, there is a locally finite open subcovering $\{\mathbf{N}_i\}_{i \in \mathbf{I}}$ for some index set \mathbf{I} which refines $\{\mathbf{N}(x)\}_{x \in \mathbf{X}}$. By (70), $P_i \in \mathbb{R}^{n \times n}$ is taken to be positive definite for each $i \in \mathbf{I}$ such that

$$\mathcal{M}(P_i, Q, x) < 0. \quad (72)$$

for all $x \in \mathbf{N}_i$.

It is known by the standard results of **continuous partitions of unity** that there is a locally Lipschitzian partition of unity $\{\psi_i\}_{i \in \mathbf{I}}$ to \mathbf{X} subordinated to the covering $\{\mathbf{N}_i\}_{i \in \mathbf{I}}$; i.e., ψ_i is locally Lipschitzian and non-negative with support $Supp(\psi_i) \subset \mathbf{N}_i$ for each $i \in \mathbf{I}$, and

$$\sum_{i \in \mathbf{I}} \psi_i(x) = 1, \forall x \in \mathbf{X}. \quad (73)$$

Define a matrix-valued function $P : \mathbf{X} \rightarrow \mathbf{P}(\mathbb{R}^{n \times n})$ as

$$P(x) = \sum_{i \in \mathbf{I}} \psi_i(x) P_i, \forall x \in \mathbf{X}, \quad (74)$$

which is positive definite and continuous since it is locally a finite sum of continuous positive definite matrix-valued functions.

It follows from (73), (74) and (69) that

$$\mathcal{M}(P(x), Q, x) = \mathcal{M}\left(\sum_{i \in \mathbf{I}} \psi_i(x) P_i, Q, x\right) = \sum_{i \in \mathbf{I}} \psi_i(x) \mathcal{M}(P_i, Q, x) < 0$$

The last equality holds since the sum is finite for each $x \in \mathbf{X}$.

Thence, the constructed \mathbf{C}^0 matrix-valued function $P : \mathbf{X} \rightarrow \mathbf{P}(\mathbb{R}^{n \times n})$ in (74) is positive definite and is a solution to $\mathcal{M}(P(x), Q, x) < 0$. \square

Remark 6.3 *The similar technique can be used to examine the continuous solutions to the following NLMI:*

$$\begin{bmatrix} x^T(A^T(x)P(x) + P^T(x)A(x) + C^T(x)QC(x))x & x^T(P^T(x)B(x) + C^T(x)QD(x)) \\ (B^T(x)P(x) + D^T(x)QC(x))x & D^T(x)QD(x) - Q \end{bmatrix} < 0, \quad (75)$$

for all $x \in \mathbf{X} \setminus \{0\}$. As a matter of fact, we can get a continuous solution $P(x)$ on $\mathbf{X} \setminus \{0\}$ to the above NLMI using the similar arguments as in the preceding proof. If $\lim_{x \rightarrow 0} P(x) = P_0 \in \mathbb{R}^{n \times n}$, then the matrix valued function $P(x)$ on $\mathbf{X} \setminus \{0\}$ can be continuously extended to \mathbf{X} by defining $P(0) = P_0$. The extension is a solution to (75) on \mathbf{X} .

A nice convex property for NLMIs is stated by the following proposition whose proof is easy and omitted here.

Theorem 6.4 *The \mathbf{C}^0 solutions $(P(x), Q)$ to NLMI $\mathcal{M}(P, Q, x) \leq 0$ such that $P : \mathbf{X} \rightarrow \mathbb{R}^{n \times n}$ and $Q > 0$ form a convex set; the subset of solutions $(P(x), Q)$ such that $P(x)$ is \mathbf{C}^0 non-negative definite with $\frac{\partial V}{\partial x}(x) = 2x^T P(x)$ for some function $V : \mathbf{X} \rightarrow \mathbb{R}$ is convex; the subset of solutions $(P(x), Q)$ such that $P(x)$ is \mathbf{C}^0 positive definite with $\frac{\partial V}{\partial x}(x) = 2x^T P(x)$ for some function $V : \mathbf{X} \rightarrow \mathbb{R}$ is also convex.*

6.2 Existence of Lyapunov Functions

As mentioned earlier, the existence of solution to NLMI (66) is not enough to give positive assertion about \mathcal{L}_2 -performance, robust stability, and robust performance; some additional requirement is imposed in this paper, i.e. there is a \mathbf{C}^1 Lyapunov function $V : \mathbf{X} \rightarrow \mathbb{R}^+$, such that

$$\frac{\partial V}{\partial x}(x) = 2p^T(x)$$

for all $x \in \mathbf{X}$. In this subsection, we will examine explicitly when it is the case for a class of such solutions.

The following result is quite standard, the reader is referred to [5] and [18] for the proofs.

Proposition 6.5 *Suppose a vector-valued function $p : \mathbf{X} \rightarrow \mathbb{R}^n$ is of class \mathbf{C}^1 ; let $p(x) = [p_1(x), \dots, p_n(x)]^T$ for $x \in \mathbf{X}$. Then there exists $V : \mathbf{X} \rightarrow \mathbb{R}$ such that*

$$\frac{\partial V}{\partial x}(x) = 2p^T(x)$$

if and only if

$$\frac{\partial p_i}{\partial x_j}(x) = \frac{\partial p_j}{\partial x_i}(x). \quad (76)$$

for all $x \in \mathbf{X}$ and $i, j = 1, 2, \dots, n$. Moreover, if (76) holds, then an function $V : \mathbf{X} \rightarrow \mathbb{R}$ with $V(0) = 0$ is given by

$$V(x) = 2x^T \int_0^1 p(tx) dt. \quad (77)$$

In addition, if $p(x) = P(x)x$ for some positive definite matrix-valued function such that $P(x)$, then $V(x)$ is also positive definite function.

For a class of solutions constructed in the proof in theorem 6.2, we can similarly characterize the existence of the Lyapunov function. The matrix-valued function $P : \mathbf{X} \rightarrow \mathbf{P}(\mathbb{R}^{n \times n})$, which satisfies $\mathcal{M}(P, x) \leq 0$, is constructed as (74)

$$P(x) = \sum_{i \in \mathbf{I}} \psi_i(x) P_i, \forall x \in \mathbf{X},$$

for some index set \mathbf{I} , where $\{\psi_i\}_{i \in \mathbf{I}}$ is a partition of unity of \mathbf{X} and $P_i = P_i^T \geq 0$. Notice that the above summation is locally finite. Similar argument leads to the following theorem.

Theorem 6.6 *Suppose the matrix valued function $P : \mathbf{X} \rightarrow \mathbf{P}(\mathbb{R}^{n \times n})$ defined by*

$$P(x) = \sum_{i \in \mathbf{I}} \psi_i(x) P_i \tag{78}$$

with $\psi_i : \mathbf{X} \rightarrow \mathbb{R}^+$ being of class \mathbf{C}^1 and $P_i \in \mathbf{P}(\mathbb{R}^{n \times n})$ for $i \in \mathbf{I}$ satisfies: $\mathcal{M}(P, x) \leq 0$ for all $x \in \mathbf{X}$; let $V_i(x) = x^T P_i x$ for all $i \in \mathbf{I}$. There exists a \mathbf{C}^2 function $V : \mathbf{X} \rightarrow \mathbb{R}$ such that $\frac{\partial V}{\partial x}(x) = 2x^T P(x)$ if and only if

$$\sum_{i \in \mathbf{I}} \frac{\partial \psi_i}{\partial x_j}(x) \cdot \frac{\partial V_i}{\partial x_l}(x) = \sum_{i \in \mathbf{I}} \frac{\partial \psi_i}{\partial x_l}(x) \cdot \frac{\partial V_i}{\partial x_j}(x) \tag{79}$$

for all $x \in \mathbf{X}$ and $j, l \in \{1, 2, \dots, n\}$ with $j \neq l$.

Notice that the summation in (79) is finite for each $x \in \mathbf{X}$.

Proof Consult [18]. □

6.3 Further Remarks and An Example

The above treatments about robustness analysis and synthesis are in terms of NLMIs, which are pointwise LMIs on state set \mathbf{X} , modulo some additional constraints on the solutions. From the proof of Theorem 6.2, we know that if \mathbf{X} is bounded, then we only need to solve a finite number of LMIs to get the solution for the NLMI on \mathbf{X} . This is different from some other recent treatments as in [6].

In the light of the notion of global linearization of nonlinear systems developed by Liu et al [15], in [6], the authors view the considered nonlinear system as a parametric uncertain system, i.e., in the current case, the coefficient matrices in (67) are assumed in a convex set:

$$[A(x), B(x), C(x), D(x)] \in Co\{[A_i, B_i, C_i, D_i]_{i \in \{1, 2, \dots, L\}}\}, \forall x \in \mathbf{X},$$

where Co stands for the **convex hull**. In this case, a constant solution $(P, Q) \in \mathbb{R}^{n \times n} \times \mathbb{R}^{q \times q}$ to (67) is sought. Therefore, if for all $i \in \{1, 2, \dots, L\}$

$$\begin{bmatrix} A_i^T P + P^T A_i + C_i^T Q C_i & P^T B_i + C_i^T Q D_i \\ B_i^T P + D_i^T Q C_i & D_i^T Q D_i - Q \end{bmatrix} \leq 0.$$

have a common constant solution (P, Q) . Then (P, Q) is also a solution to (67), i.e.,

$$\begin{bmatrix} A^T(x)P + P^T A(x) + C^T(x)QC(x) & P^T B(x) + C^T(x)QD(x) \\ B^T(x)P + D^T(x)QC(x) & D^T(x)QD(x) - Q \end{bmatrix} \leq 0.$$

The solution automatically satisfies the condition (76), and the corresponding Lyapunov function is $V(x) = x^T P x$.

This treatment suggests a tractable algorithm to get local solutions, which can be used to seek constant solutions on each partitioned state set N_i in the proof of theorem 6.2. However, this approach generally leads to conservative results if the prescribed state set is large enough. This can be seen in the following example.

Example 6.7 Consider an uncertain feedback system with diagram as follows.

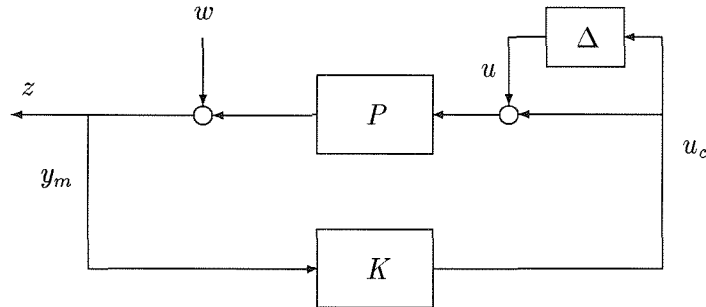

Where P is the nonlinear plant; K is the controller such that the output z is supposed to be regulated; y_m is the measured output, based on which the control action u_c is produced; w is the disturbance from the actuator; and u is the disturbance from the sensor which is generated by $u = \Delta u_c$ with Δ being the bounded causal uncertainties. The **robustness analysis problem** is to check that for a given controller K , whether or not the influence of the noises w on the regulated output z is reduced to the required degree for all possible Δ .

To formulate this problem, all the signals are considered in space $\mathcal{L}_2[0, \infty)$. We will check that given $\gamma > 0$ and K , does

$$\int_0^T \|z\|^2 dt \leq \gamma^2 \int_0^T \|w\|^2 dt, \forall T \in \mathbb{R}^+,$$

for all admissible Δ ?

In this example , the plant has the following realization:

$$\begin{cases} \dot{x} = e^x(u + u_c) \\ z = x + w \\ y_m = x + w \end{cases}$$

and the controller $K = -1$, each admissible uncertainty Δ has \mathcal{L}_2 -gain $\leq \frac{1}{\sqrt{2}}$. We will check if the \mathcal{L}_2 -gain $\leq \frac{1}{\sqrt{2}}$. To this end, the standardized block diagram for the closed system is redrawn as follows

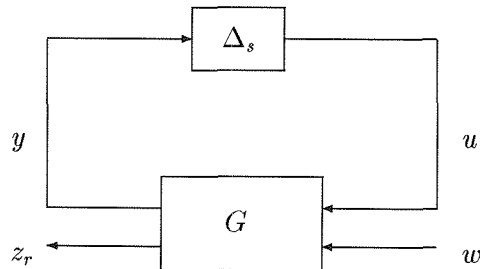

with

$$G : \begin{cases} \dot{x} = -e^x x - e^x u + e^x w \\ y = -\frac{1}{\sqrt{2}}x - \frac{1}{\sqrt{2}}u \\ z_r = \frac{1}{\sqrt{2}}x + \frac{1}{\sqrt{2}}u \end{cases}$$

Therefore, $z_r = \sqrt{2}z$. In this case, the admissible uncertainty $\Delta_s = \sqrt{2}\Delta$ is assumed to have the following realization:

$$\begin{cases} \dot{\xi} = f(\xi, t, y) \\ u = h(\xi, t, y) \end{cases}$$

which evolves on \mathbb{R}^l for some integer l , and $\dot{\xi} = f(\xi, t, 0)$ is asymptotically stable at $0 \in \mathbb{R}^l$; in addition, there exists a \mathbf{C}^1 storage function U such that $\dot{U}(\xi) \leq \|y\|^2 - \|u\|^2 + \psi(\xi)$ with some negative definite function $\psi : \mathbb{R}^l \rightarrow \mathbb{R}^+$.

It is sufficient to check if the above feedback system has robust performance. We first consider $z_N := \epsilon z_r = \epsilon(\frac{1}{\sqrt{2}}x + \frac{1}{\sqrt{2}}u)$ for some positive $\epsilon < 1$. Consider the following NLMI,

$$\begin{bmatrix} -2e^x P(x) + \frac{1}{2}(Q + \epsilon^2) & -e^x P(x) + \frac{1}{2}(Q + \epsilon^2) & e^x P(x) \\ -e^x P(x) + \frac{1}{2}(Q + \epsilon^2) & \frac{1}{2}(\epsilon^2 - Q) & 0 \\ e^x P(x) & 0 & -1 \end{bmatrix} < 0$$

which implies the NLMI in theorem 4.3 and is equivalent to

$$\begin{bmatrix} -2e^x P(x) + \frac{1}{2}(Q + \epsilon^2) + e^{2x} P^2(x) & -e^x P(x) + \frac{1}{2}(Q + \epsilon^2) \\ -e^x P(x) + \frac{1}{2}(Q + \epsilon^2) & \frac{1}{2}(\epsilon^2 - Q) \end{bmatrix} < 0$$

or

$$\epsilon^2 - Q < 0 \tag{80}$$

$$-(2 + Q - \epsilon^2)e^{2x} P^2(x) + 4Q^2 e^x P(x) - 2Q(\epsilon^2 + 1) > 0. \tag{81}$$

There exist positive solutions $(Q, P(x))$ to the above two inequalities; they satisfy $Q = 1$ and $\frac{1+\epsilon^2}{3-\epsilon^2}e^{-x} < P(x) < e^{-x}$. Hence,

$$\int_0^T \|z_N\|^2 dt \leq \int_0^T \|w\|^2 dt, \forall T \in \mathbb{R}^+,$$

Therefore, the \mathcal{L}_2 -gain for the closed loop system $\leq \frac{1}{\sqrt{2}\epsilon}$ for all $\epsilon < 1$, which in turn implies the \mathcal{L}_2 -gain $\leq \frac{1}{\sqrt{2}}$. However, it is obvious that there is no constant pair (P, Q) which satisfies both (80) and (81) for all $x \in \mathbb{R}$.

7 Concluding Remarks: Robust BIBO Stability and the Scaled Small Gain Theorem

This paper deals with the robustness analysis and synthesis for nonlinear systems in the state space. The characterizations are in terms of NLMIs which offer some computationally attractive properties. In an input-output point of view, the characterizations imply that both (structured) uncertainty and a (scaled) nominal plant have \mathcal{L}_2 -gain ≤ 1 . It is noted that the scaling treatment

for the robust performance problem or robust stability analysis in the structured uncertainty case is a reasonable way to reduce the possible conservatism arising from the structural constraints of the uncertainty.

As a matter of fact, the robust stability and performance conditions in this paper can be strengthened using BIBO stability instead of asymptotic stability and a scaled small gain theorem. Under weaker assumptions on the uncertainty the scaled small gain theorem is necessary as well as sufficient, and can be related directly to conditions of Theorems 3.5 and 4.3. To examine the robust stability of a uncertain system in the input-output setting, consider the following block diagram,

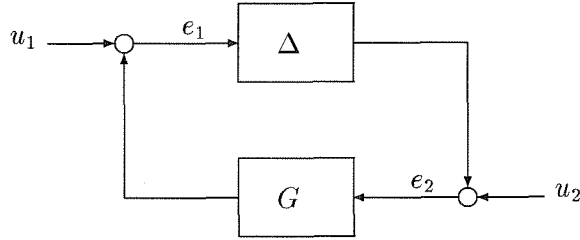

where the uncertainty Δ is causal and possibly nonlinear and time-varying with \mathcal{L} -gain < 1 , the nominal system G is nonlinear time-invariant and causal. For the purposes of this section, no realizations for Δ or G need be assumed. The feedback structure is assumed to be well-posed for any admissible uncertainty. The robust BIBO stability requires that if for some $T \in \mathbb{R}^+$, and u_1 and u_2 such that $\|P_T u_1\|_2 < \infty$ and $\|P_T u_2\|_2 < \infty$, then $\|P_T e_1\|_2 < \infty$ and $\|P_T e_2\|_2 < \infty$; in addition, if $u_1, u_2 \in \mathcal{L}_2(\mathbb{R}^+)$, then $e_1, e_2 \in \mathcal{L}_2(\mathbb{R}^+)$.

For this system, the following assumption is made.

Assumption 7.1 (i) *The admissible uncertainty set is*

$$\mathbf{B}\Delta := \{\text{block-diag}\{\Delta_1, \dots, \Delta_N\} : \Delta_i \text{ is causal and has } \mathcal{L}_2\text{-gain} < 1, \text{ for each } i\};$$

(ii) *The nominal system is time-invariant and causal; in addition, given any $\epsilon > 0$, there is a function $\phi : \mathcal{L}_2^\epsilon(\mathbb{R}^+) \times \mathbb{R}^+ \rightarrow \mathbb{R}^+$ such that for all $u \in \mathcal{L}_2^\epsilon(\mathbb{R}^+)$ and $t \in \mathbb{R}^+$, $\phi(u, t) = \phi(P_t u, t) \geq t$ and*

$$\|(I - P_{\phi(u,t)})Gu - (I - P_{\phi(u,t)})G(I - P_t)u\|_2 \leq \epsilon \|P_t u\|_2$$

where P_t is the truncation operator.

Defining the scaling matrix set \mathcal{D} as before, the following result is essentially from [27, 28, 20, 26].

Proposition 7.2 (Scaled Small Gain Theorem) *Under assumption 7.1 (i), the uncertain system depicted above is robustly BIBO stable if there is $D \in \mathcal{D}$ such that the scaled nominal system DGD^{-1} has \mathcal{L}_2 -gain ≤ 1 ; i.e.,*

$$\int_0^T \|DGD^{-1}u\|^2 dt \leq \int_0^T \|u\|^2 dt \quad (82)$$

for all $T \in \mathbb{R}^+$, and $u \in \mathcal{L}_2[0, T]$. Moreover, under additional assumption 7.1 (ii), the condition (82) is also necessary for robust BIBO stability.

The nonlinear time-invariant systems satisfying assumption 7.1 (ii) are said to have **fading memory** (in \mathcal{L}_2 sense) [30]. It is noted that the scaling treatment for the sufficient conditions of Theorem 3.5 is essentially motivated by combining the scaled small gain condition in this proposition with the one on \mathcal{L}_2 -gain characterizations in section 2. However, the necessity of the conditions in Theorem 3.5 is not as immediate, one of the reasons is that the systems may not have fading memory. Nevertheless, only a weaker notion of the fading memory about the nominal system is needed for the above proposition to hold [30], and a large class of the nominal plants considered in this paper have weak fading memory (this issue is discussed in a forthcoming article).

Acknowledgements

The authors would like to thank J.W. Helton and J.S. Shamma for fruitful and extensive discussions. They also gratefully acknowledge helpful comments about the original version of this paper from Y.Huang, J.Morris, and K.Zhou. Support for this work was provided by NSF, AFOSR, and ONR.

References

- [1] Apkarian, P. and P. Gahinet (1993), “A Convex Characterization of Parameter-Dependent \mathcal{H}_∞ Controllers”, *Submitted to IEEE Trans. AC*.
- [2] Ball, J.A. and J.W. Helton (1992), “Interconnection of Nonlinear Causal Systems”, *IEEE Trans., AC*, Vol.34, pp.1132–1140.
- [3] Ball, J.A., J.W. Helton and M.L. Walker (1993), “ \mathcal{H}_∞ Control for Nonlinear Systems with Output Feedback”, *IEEE Trans. AC*, Vol.38, pp.546 – 559.
- [4] Bercovici, H., C. Foias, and T. Tennenbaum (1990), “Structured Interpolation Theory”, *Operator Theory Advances and Applications*, Vol.47, pp. 195 – 220.
- [5] Berger, M. and M. Berger (1963), *Perspective in Nonlinearity: An Introduction to Nonlinear Analysis*, New York: W.A. Benjamin, Inc..
- [6] Boyd, S.P., L El Ghaoui, E. Feron, and V. Balakrishnan (1994), *Linear Matrix Inequalities in System and Control Theory*, To be published by SIAM, April 1994.
- [7] Chen, M.J. and C.A. Desoer (1982), “Necessary and Sufficient Condition for Robust Stability of Linear Distributed Feedback Systems”, *Int. J. Control*, Vol.35, pp. 255–267.
- [8] Dahleh, M.A. and M.H. Khammash (1993), “Controller Design for Plants with Structured Uncertainty”, *Automatica*, Vol.29, pp.37 – 56.
- [9] Doyle, J.C. (1982), “Analysis of Feedback Systems with Structured Uncertainties”, *IEE Proceedings*, Part D, Vol. 129, pp. 242 – 250.
- [10] Doyle, J.C. and G. Stein (1981), “Multivariable Feedback Design: Concepts for a Classical/Modern Synthesis”, *IEEE Trans. AC*, Vol.AC-26, pp. 4 – 16.
- [11] Doyle, J.C., J.E. Wall and G. Stein (1982), “Performance and Robustness Analysis for Structured Uncertainty”, *proc. 21st IEEE CDC*, pp. 629 – 636.

- [12] Doyle, J.C., K.Glover, Khargonekar and B.Francis (1989), “State-Space Solutions to Standard \mathcal{H}_2 and \mathcal{H}_∞ Control Problems”, *IEEE Trans. AC*, vol.AC-34, pp.831 – 847.
- [13] Glover, K. and J.C. Doyle (1989), “A State Space Approach to \mathcal{H}_∞ Optimal Control”, *Three Decades of Mathematical System Theory* (H.Nijmeijer, J.M.Schumacher Eds.), Berlin: Springer-Verlag, pp.179 – 218.
- [14] Khammash, M.H. and J.B. Pearson (1991), “Performance Robustness of discrete-Time Systems with Structured Uncertainty”, *IEEE Trans. AC*, Vol.AC-36, pp.398–412.
- [15] Liu, R., R. Saeks, and R.J. Leake (1969), “On Global Linearization”, *SIAM-AMS Proceedings*, Vol.III, pp.93 – 102.
- [16] Lu, W.M. and J.C. Doyle (1992), “ \mathcal{H}_∞ -Control of LFT Systems: An LMI Approach”, *Proc. 31st IEEE CDC*, Tucson, AZ., pp. 1997–2001.
- [17] Lu, W.M. and J.C. Doyle (1993), “ \mathcal{H}_∞ -Control of Nonlinear Systems: A Class of Controllers”, *Caltech CDS Tech. Memo.*, No.CIT-CDS-93-008; also *Proc. 32nd IEEE CDC*, San Antonio, TX., pp.166–171.
- [18] Lu, W.M. and J.C. Doyle (1993), “ \mathcal{H}_∞ -Control of Nonlinear Systems: a Convex Characterization”, *Caltech CDS Tech. Memo.*, No.CIT-CDS-93-020.
- [19] Lu, W.M., K. Zhou and J.C. ,Doyle (1991), “Stabilization of Linear Systems under Structured Perturbation”, *Caltech CDS Tech. Memo.*, No.CIT-CDS-93-014; also “Stabilization of LFT Systems”, *Proc. 30th IEEE CDC*, Brighton, England, pp.1239–1244.
- [20] Megretski, A. (1993), “Necessary and Sufficient Conditions of Stability: A Multiloop Generalization of Circle Criterion”, *IEEE Trans. AC*, Vol.38, pp.753 –756.
- [21] Packard, A., J.C. Doyle (1993), “The Complex Structured Singular Value”, *Automatica*, Vol.29, pp.71 – 109.
- [22] Packard, A., K. Zhou, P. Pandey, and G. Becker (1991), “A Collection of Robust Control Problems Leading to LMIs”, *Proc. of 1991 IEEE CDC*, Brighton, England, pp.1245 – 1250.
- [23] Packard, A., K. Zhou, P. Pandey, and G. Balas (1992), “Optimal, Constant I/O Similarity Scaling for Full-Information and State-Feedback Problems”, *Systems and Control Letters*, Vol.19, pp.271 – 280.
- [24] Poolla, K., and A. Tikku (1993), “Robust Performance against Time-Varying Structured Perturbations”, *Proc. 1993 IEEE CDC*, San Antonio, TX.
- [25] Sandberg, J.W. (1965), “An Observation Concerning the Application of the Contraction Mapping Fixed-Point Theorem and a Result Concerning the Norm-Boundedness of Solutions of Nonlinear Functional Equations”, *Bell Systems Technical Journal*, Vol. 44, pp. 1809 – 1812.
- [26] Savkin, A.V. and I.R. Petersen (1993), “Nonlinear versus Linear Control in the Absolute Stabilizability of Uncertain Systems with Structured Uncertainty”, *Proc. 1993 IEEE CDC*, San Antonio, TX., pp. 172 –177.

- [27] Shamma, J.S. (1991), “The Necessity of Small-Gain Theorem for Time-Varying and Nonlinear Systems”, *IEEE Trans. AC*, Vol. AC-36, pp. 1138 – 1147.
- [28] Shamma, J.S. (1992), “Robust Stability with Time-Varying Structured Uncertainty”, To appear in *IEEE Trans. AC*.
- [29] Shamma, J.S. (1993), *Private Communication*.
- [30] Shamma, J.S. and R. Zhao (1993), “Fading Memory Feedback Systems and Robust Stability”, *Automatica*, Vol.29, pp.191 – 200.
- [31] Van der Schaft, A.J. (1992), “ \mathcal{L}_2 -Gain Analysis of Nonlinear Systems and Nonlinear State Feedback \mathcal{H}_∞ -Control”, *IEEE Trans. AC*, Vol.AC-37,pp.770–784.
- [32] Van der Schaft, A.J. (1993), “Robust Stabilization of Nonlinear Systems via Stable Kernel Representations with \mathcal{L}_2 -Gain Bounded Uncertainty”, *Submitted for Publication*.
- [33] Vidyasagar, M.(1993), *Nonlinear Systems Analysis* (2nd ed.), Englewood Cliffs, NJ: Prentice Hall.
- [34] Willems, J.C. (1971), *The Analysis of Feedback Systems*, Cambridge, MA: MIT Press.
- [35] Willems, J.C.(1972), “Dissipative Dynamical Systems”, *Arch. Rat. Mech. Anal.*, vol.45, pp.321–393.
- [36] Zames, G. (1966), “On the Input-Output Stability of Time-varying Nonlinear Feedback Systems: Conditions Using Concepts of Loop Gain, Conicity, and Positivity”, *IEEE Trans. AC*, Vol.AC-11, pp.228–238.