



**NAVAL  
POSTGRADUATE  
SCHOOL**

**MONTEREY, CALIFORNIA**

**THESIS**

**WIRELESSLY NETWORKED OPPORTUNISTIC DIGITAL  
PHASED ARRAY: SYSTEM ANALYSIS AND  
DEVELOPMENT OF A 2.4 GHZ DEMONSTRATOR**

by

Eng Choon Yeo

December 2006

Thesis Co-Advisors:

David Jenn  
Donald Walters

**Approved for public release; distribution is unlimited**

THIS PAGE INTENTIONALLY LEFT BLANK

<b>REPORT DOCUMENTATION PAGE</b>			<i>Form Approved OMB No. 0704-0188</i>
Public reporting burden for this collection of information is estimated to average 1 hour per response, including the time for reviewing instruction, searching existing data sources, gathering and maintaining the data needed, and completing and reviewing the collection of information. Send comments regarding this burden estimate or any other aspect of this collection of information, including suggestions for reducing this burden, to Washington headquarters Services, Directorate for Information Operations and Reports, 1215 Jefferson Davis Highway, Suite 1204, Arlington, VA 22202-4302, and to the Office of Management and Budget, Paperwork Reduction Project (0704-0188) Washington DC 20503.			
<b>1. AGENCY USE ONLY (Leave blank)</b>	<b>2. REPORT DATE</b> December 2006	<b>3. REPORT TYPE AND DATES COVERED</b> Master's Thesis	
<b>4. TITLE AND SUBTITLE</b> Wirelessly Networked Opportunistic Digital Phased Array: System Analysis and Development of a 2.4 GHz Demonstrator		<b>5. FUNDING NUMBERS</b>	
<b>6. AUTHOR(S)</b> Eng Choon Yeo		<b>8. PERFORMING ORGANIZATION REPORT NUMBER</b>	
<b>7. PERFORMING ORGANIZATION NAME(S) AND ADDRESS(ES)</b> Naval Postgraduate School Monterey, CA 93943-5000		<b>10. SPONSORING/MONITORING AGENCY REPORT NUMBER</b>	
<b>9. SPONSORING /MONITORING AGENCY NAME(S) AND ADDRESS(ES)</b> Office of Naval Research Arlington, Virginia		<b>11. SUPPLEMENTARY NOTES</b> The views expressed in this thesis are those of the author and do not reflect the official policy or position of the Department of Defense or the U.S. Government.	
<b>12a. DISTRIBUTION / AVAILABILITY STATEMENT</b> Approved for public release; distribution is unlimited		<b>12b. DISTRIBUTION CODE</b>	
<b>13. ABSTRACT (maximum 200 words)</b> <p>The concept of a wirelessly networked opportunistic digital phased array radar brings about the added advantages of stealth, enhanced survivability, and maximum maneuverability. The array elements are spread over a wide range of locations on the ship's hull and superstructure, and the Local Oscillator (LO) and data/control signals are wirelessly transmitted to and from a central computer processor, which also performs as the digital beamformer.</p> <p>As part of the ongoing research effort, this thesis focused on the hardware and software development of a 2.4 GHz two-element array demonstrator. A system analysis of a generic distributed array radar was done and some key parameters pertaining to the Transmit/Receive (T/R) module and an eight-element array radar were calculated. In addition, the research analyzed the radar waveform properties, sampling and data rates, the digital beamformer concept and requirements, and assessed their impacts on the radar performance.</p> <p>Two Transmit/Receive (T/R) modules were built and a two-element array test bench developed using the various National Instruments Compact Reconfigurable Input and Output (cRIO) and Field Programmable Gate Array (FPGA) modules. The main software, written in LabVIEW, allowed the test bench to demonstrate the proper functionalities of transmission and reception of the T/R modules. The hardware and software code could be extended easily for an eight-element array radar.</p> <p>Lastly, a number of measurements to characterize the T/R module were done. No significant interference between the modulator and demodulator boards inside of the compact T/R module chassis was observed.</p>			
<b>14. SUBJECT TERMS</b> Phased Array, Distributed Array Radar, Opportunistic Phased Array, Aperstructure, Radar, Digital Radar, Modulator, Demodulator, Transmit/ Receive Module, Digital Beamforming, Array Demonstrator.		<b>15. NUMBER OF PAGES</b> 92	
		<b>16. PRICE CODE</b>	
<b>17. SECURITY CLASSIFICATION OF REPORT</b> Unclassified	<b>18. SECURITY CLASSIFICATION OF THIS PAGE</b> Unclassified	<b>19. SECURITY CLASSIFICATION OF ABSTRACT</b> Unclassified	<b>20. LIMITATION OF ABSTRACT</b> UL

THIS PAGE INTENTIONALLY LEFT BLANK

**Approved for public release; distribution is unlimited**

**WIRELESSLY NETWORKED OPPORTUNISTIC DIGITAL PHASED ARRAY:  
SYSTEM ANALYSIS AND DEVELOPMENT OF A 2.4 GHZ DEMONSTRATOR**

Eng Choon Yeo  
Civilian, Ministry of Defence, Singapore  
B. Eng. (Electrical & Electronic), Nanyang Technological University, 1996  
MSc. (Electrical Engineering), National University of Singapore, 2000

Submitted in partial fulfillment of the  
requirements for the degree of

**MASTER OF SCIENCE IN COMBAT SYSTEMS SCIENCE AND  
TECHNOLOGY**

from the

**NAVAL POSTGRADUATE SCHOOL  
December 2006**

Author: Eng Choon Yeo

Approved by: David Jenn  
Thesis Advisor

Donald Walters  
Thesis Advisor

James Luscombe  
Chairman, Department of Physics

THIS PAGE INTENTIONALLY LEFT BLANK

## ABSTRACT

The concept of a wirelessly networked opportunistic digital phased array radar brings about the added advantages of stealth, enhanced survivability, and maximum maneuverability. The array elements are spread over a wide range of locations on the ship's hull and superstructure, and the Local Oscillator (LO) and data/control signals are wirelessly transmitted to and from a central computer processor, which also performs as the digital beamformer.

As part of the ongoing research effort, this thesis focused on the hardware and software development of a 2.4 GHz two-element array demonstrator. A system analysis of a generic distributed array radar was done and some key parameters pertaining to the Transmit/Receive (T/R) module and an eight-element array radar were calculated. In addition, the research analyzed the radar waveform properties, sampling and data rates, the digital beamformer concept and requirements, and assessed their impacts on the radar performance.

Two Transmit/Receive (T/R) modules were built and a two-element array test bench developed using the various National Instruments Compact Reconfigurable Input and Output (cRIO) and Field Programmable Gate Array (FPGA) modules. The main software, written in LabVIEW, allowed the test bench to demonstrate the proper functionalities of transmission and reception of the T/R modules. The hardware and software code could be extended easily for an eight-element array radar.

Lastly, a number of measurements to characterize the T/R module were done. No significant interference between the modulator and demodulator boards inside of the compact T/R module chassis was observed.

THIS PAGE INTENTIONALLY LEFT BLANK

# TABLE OF CONTENTS

<b>I.</b>	<b>INTRODUCTION.....</b>	<b>1</b>
	A. <b>BACKGROUND .....</b>	<b>1</b>
	B. <b>PREVIOUS WORK.....</b>	<b>3</b>
	C. <b>THESIS OBJECTIVE .....</b>	<b>5</b>
	D. <b>THESIS ORGANIZATION.....</b>	<b>5</b>
<b>II.</b>	<b>SYSTEM ARCHITECTURE .....</b>	<b>7</b>
	A. <b>WIRELESSLY NETWORKED DISTRIBUTED DIGITAL ARRAY RADAR CONCEPT.....</b>	<b>7</b>
	B. <b>WIRELESS SENSOR NETWORKS .....</b>	<b>10</b>
	C. <b>CONFORMAL AND MULTI-FUNCTION ARRAYS .....</b>	<b>11</b>
	D. <b>ADVANCES IN MICROELECTRONICS AND SIGNAL PROCESSING.....</b>	<b>11</b>
	1. <b>Field Programmable Gate Arrays (FPGAs).....</b>	<b>12</b>
	2. <b>Direct Digital Synthesis (DDS).....</b>	<b>12</b>
	E. <b>DIGITAL BEAMFORMING .....</b>	<b>14</b>
	F. <b>TIMING AND SYNCHRONIZATION .....</b>	<b>18</b>
	1. <b>Wireless LO and Synchronization.....</b>	<b>18</b>
	2. <b>Element Geolocation.....</b>	<b>20</b>
<b>III.</b>	<b>DISTRIBUTED ARRAY RADAR DESIGN AND ANALYSIS.....</b>	<b>21</b>
	A. <b>T/R MODULE ANALYSIS.....</b>	<b>21</b>
	1. <b>Receiver Noise Figure, Effective Temperature and Noise Floor ...</b>	<b>21</b>
	2. <b>Sensitivity and Dynamic Range .....</b>	<b>22</b>
	3. <b>Maximum Power Output of T/R Module .....</b>	<b>23</b>
	B. <b>DISTRIBUTED ARRAY RADAR ANALYSIS.....</b>	<b>23</b>
	1. <b>System Noise Temperature and Noise Factor .....</b>	<b>24</b>
	2. <b>Radar Range Equation.....</b>	<b>25</b>
	3. <b>Signal-to-Noise Ratio and Detection Range.....</b>	<b>27</b>
	4. <b>Waveform, Sampling Rate and Data Rate .....</b>	<b>28</b>
	5. <b>Digital Beamformer (DBF) Performance .....</b>	<b>31</b>
	6. <b>Transmitter Leakage .....</b>	<b>32</b>
<b>IV.</b>	<b>HARDWARE AND SOFTWARE DEVELOPMENT .....</b>	<b>37</b>
	A. <b>ELECTRICAL DESIGN OF T/R MODULE.....</b>	<b>37</b>
	1. <b>Power Divider.....</b>	<b>38</b>
	2. <b>RF Cable Assemblies .....</b>	<b>39</b>
	3. <b>Optimum AD8346 and AD8347 Settings .....</b>	<b>40</b>
	B. <b>MECHANICAL DESIGN OF T/R MODULE.....</b>	<b>41</b>
	C. <b>CONTROLLER AND DATA ACQUISITION SYSTEM .....</b>	<b>42</b>
	1. <b>cRIO Embedded System .....</b>	<b>42</b>
	2. <b>cRIO Reconfigurable Chassis and Controller.....</b>	<b>43</b>
	3. <b>NI-9263 Analog Output Module .....</b>	<b>43</b>
	4. <b>NI-9215 Analog Input Module.....</b>	<b>43</b>

5.	Software Model .....	44
6.	Arbitrary Waveform Generation .....	44
D.	TWO-ELEMENT ARRAY DEMONSTRATOR TEST BENCH.....	45
E.	LABVIEW PROGRAM.....	47
1.	LabVIEW Project Structure.....	47
2.	User Interface.....	48
V.	MEASUREMENTS AND RESULTS .....	51
A.	DC POWER CONSUMPTION .....	51
B.	INTERFERENCE BETWEEN THE MODULATOR AND DEMOMULATOR BOARDS .....	51
1.	Transmit Output when Demodulator is On/Off .....	51
2.	Receive Output When Modulator is On/Off .....	53
C.	TRANSMIT AND RECEIVE DELAYS.....	55
1.	Transmit Delay.....	55
2.	Receive Delay.....	58
D.	SIMULTANEOUS TRANSMISSION AND RECEPTION.....	60
1.	Simultaneous Transmission .....	60
2.	Simultaneous Reception .....	61
E.	PHASE ERROR MEASUREMENT.....	63
F.	S <sub>11</sub> OF T/R MODULE RF PORT .....	65
VI.	CONCLUSIONS AND RECOMMENDATIONS.....	67
A.	CONCLUSIONS .....	67
B.	RECOMMENDATIONS FOR FUTURE WORK.....	68
1.	Expand the Array Demonstrator Test Bench .....	68
2.	Time and Phase Synchronization Method.....	68
3.	Transmit Leakage Reduction or Cancellation Method.....	69
	LIST OF REFERENCES.....	71
	INITIAL DISTRIBUTION LIST .....	75

## LIST OF FIGURES

Figure 1.	Systems on the DDG1000 destroyer (From [1]).....	1
Figure 2.	WNDDAR concept (From [2]) .....	7
Figure 3.	Block diagram of T/R module in array (From [10]) .....	8
Figure 4.	Proposed communication architecture for the WNDDAR (From [9]) .....	10
Figure 5.	FPGA in a typical digital radar (From [13]) .....	12
Figure 6.	Block diagram of a typical DDS (From [14]).....	13
Figure 7.	Time delay between array elements.....	14
Figure 8.	Digital beamforming process using IF (From [16]).....	16
Figure 9.	I-Q Conversion (From [2]).....	17
Figure 10.	Digital beamforming process for a transmit array at VHF/UHF .....	18
Figure 11.	Diagram of possible synchronization circuit in T/R module (From [10]) .....	19
Figure 12.	LO phase synchronization concept (From [10]) .....	19
Figure 13.	Block diagram of T/R module .....	21
Figure 14.	Distributed array radar (After [10]) .....	24
Figure 15.	Target return vs. reflected and reverse leakage (After [2]).....	33
Figure 16.	Schematic of T/R module .....	37
Figure 17.	Amplitude balance of power divider.....	39
Figure 18.	Phase balance of power divider .....	39
Figure 19.	Insertion loss and phase measurements of RF cable assembly.....	40
Figure 20.	Assembled T/R module.....	41
Figure 21.	cRIO modules (From [2]) .....	42
Figure 22.	Software model (From [2]) .....	44
Figure 23.	Block diagram of two-element array demonstrator test bench .....	46
Figure 24.	Two-element array demonstrator test bench.....	46
Figure 25.	LabVIEW project structure.....	47
Figure 26.	Demonstrator user interface.....	49
Figure 27.	Setup for measuring demodulator's effect on transmitter output .....	52
Figure 28.	Transmit output when demodulator was off .....	52
Figure 29.	Transmit output when demodulator was on.....	53
Figure 30.	Setup for measuring modulator's effect on received output.....	54
Figure 31.	Receive output when modulator was off .....	54
Figure 32.	Receive output when modulator was on .....	55
Figure 33.	Setup for measuring transmit delay .....	56
Figure 34.	Transmit delay (rising edge).....	56
Figure 35.	Transmit delay (falling edge).....	57
Figure 36.	Transmit delay (rising edge) with function generator.....	57
Figure 37.	Transmit delay (falling edge) with function generator .....	58
Figure 38.	Setup for measuring receive delay .....	59
Figure 39.	Receive delay (rising edge).....	59
Figure 40.	Setup for testing synchronous transmission.....	60
Figure 41.	Simultaneous transmit off to on.....	61
Figure 42.	Simultaneous transmit on to off.....	61

Figure 43.	Setup for testing synchronous reception .....	62
Figure 44.	Simultaneous receive on to off .....	62
Figure 45.	Setup for phase error measurement.....	63
Figure 46.	Plot of received phase vs. transmitted phase .....	64
Figure 47.	$S_{11}$ of RF port of T/R module.....	66

## LIST OF TABLES

Table 1.	Summary of performance analysis of the T/R module .....	35
Table 2.	Summary of performance/requirement analysis of an eight-element array .....	36
Table 3.	RF component list of T/R module .....	38
Table 4.	Summary of performance of power divider .....	38
Table 5.	Definition of RF cable assemblies used in T/R module .....	40
Table 6.	Definition of screws used in T/R module .....	42
Table 7.	DC power consumption of T/R module .....	51
Table 8.	Measured received I and Q voltages and phase (with differential input amplitude of 2 V) .....	65
Table 9.	Summary for the T/R module .....	67
Table 10.	Summary for an eight-element array .....	67

THIS PAGE INTENTIONALLY LEFT BLANK

## ACKNOWLEDGMENTS

I would like to thank Professor David Jenn for his patience and guidance in my thesis effort. He has shown me the finer points of conducting good research, which I will, to the best of my abilities, emulate when I am back to my organization in Singapore.

I would also like to extend my gratitude to Professor Donald Walters for sharing his knowledge and experience during our discussion sessions. I will always remember to develop a “physical” perspective of things.

Special thanks also go to Mr. Robert Broadston, Microwave Laboratory Director, who helped in the various tasks along the way, big and small.

Last but not least, I would not have such a fulfilling experience in the USA if not for my wife Clara, who sacrificed her career to accompany me, as well as my two children, Jing Xi and Zhi Lin. I will forever treasure the wonderful moments we have shared in the USA.

THIS PAGE INTENTIONALLY LEFT BLANK

# I. INTRODUCTION

## A. BACKGROUND

Phased array radars continue to be an integral part of the next generation military platforms. The DDG1000 Future Surface Combatant developed under the DD(X) Program, the Joint Strike Fighter (JSF) and the MILSTAR satellite communications system are examples.

In the DDG1000, the Zumwalt-class guided missile destroyer is equipped with both a X-band Multi-Function Radar (MFR) called the AN/SPY-3 and a S-band Volume Search Radar (VSR) [1]. These radars use phased arrays to enable the destroyer to detect cruise missiles, small boats, periscopes and floating mines in a littoral environment. As can be seen in Figure 1, the electronically steered phased array radars are embedded in the ship's structure in order to reduce its Radar Cross Section (RCS) and thus achieve stealth.

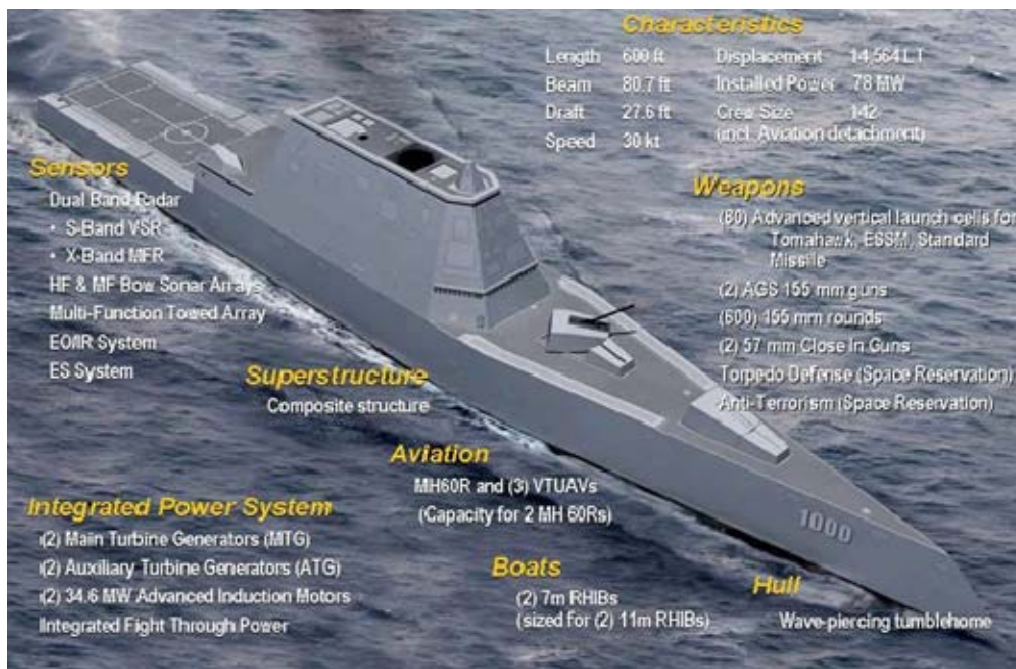

Figure 1. Systems on the DDG1000 destroyer (From [1])

Ballistic Missile Defence (BMD) has always been a concern but in recent months, a specific threat has increased. North Korea has been conducting missile tests in July

2006 and even a reported nuclear test in September 2006. Their Taepo Dong missile has a claimed range of 9,000 miles which literally means North Korea is capable of launching a missile to hit the USA. As part of the National Missile Defence (NMD) program, which has been in development since the Reagan years, there is a need for a ready and capable BMD system to counter this threat.

At present, the US Early Warning Radars are the land-based PAVE-PAWS (AN/FPS-115) and the Cobra Dane (AN/FPS-108). The ship-based Aegis radar (AN/SPY-1) has the potential to perform BMD functions but the radar may be overloaded if it is now required to detect missile launches, in addition to searching for and tracking its normal targets. Furthermore, these radars operate in the S-band or above which, due to propagation losses, limits their maximum range. Thus, most shipboard radars will not be able to reach the 1000 km or more detection range required by a BMD system [2]. At such large distances, the angular resolution is also limited in ensuring proper tracking of the launched missile(s).

One potential solution is to operate in the VHF/UHF band. The radar's angular resolution determined approximately by

$$\theta = \frac{\lambda}{D} \text{ rad} \quad (1)$$

can be further improved if  $D$ , the length of the array, is large compared to its wavelength. Conventionally, as the ship's structure must accommodate its radar which needs to fulfill its intended functions, the radar is usually positioned high on a mast or occupies a dedicated area on the ship. The Office of Naval Research (ONR) developed a new **aperstructure** concept of building the phased array radar around a ship's structure. The array elements are spread over available locations around the ship's superstructure and hull, thus making  $D$  close to the length of the ship. If the length of the DDG1000 is about 600 ft (or 182.88 m) according to [1], and the radar operates at 300 MHz, the achievable resolution will be 0.3 degree.

This concept brings about the potential of using a **distributed** or **opportunistic** array which has added advantages of increased flexibility, survivability and operational availability. Further, by adopting a **digital** architecture that employs the advanced signal

processing techniques available today, the phased array can be made multi-beam, multi-functional and even networked with other communication systems.

The US Naval Postgraduate School (NPS), with funding from ONR, has been involved in this research area for the past few years. The wirelessly networked distributed digital phased array radar concept and architecture will be discussed in more detail in Chapter II.

## **B. PREVIOUS WORK**

Previous thesis research has addressed several aspects of the digital phased array radar and its design.

Esswein [3] used the concept of Genetic Algorithms (GA) to model and test distributed phased array designs. A test-bed transmit antenna consisting of 24 elements, developed at 2.4 GHz using the commercially available AD8346 modulator from Analog Devices, was designed and tested. The measured patterns were in good agreement with those obtained using GA and the established Method of Moments (MM).

Eng [4] evaluated approaches for the complementary receive array and found the most cost effective option to be that of each array element having its own low-cost I-Q demodulator and Analog-to-Digital Converter (ADC), the outputs of which are fed back to a National Instruments PXI-1042 Data Acquisition and Signal Analyzer. It was also determined that while the AD8347 demodulator from Analog Devices did not have wideband phase characteristics, it was adequate for the purpose of research at that stage.

Ong C.S. [5] calculated the element spacing to be between  $0.33\lambda$  and  $0.5\lambda$  in order to avoid mutual coupling effects and grating lobes respectively. A test setup using the AD8346 modulator, AD9854 Direct Digital Synthesizer (DDS) evaluation board and associated software determined that the AD8346 modulator was not able to suppress the image sideband adequately and needed a bandpass filter.

Ong W. [6] studied the different waveforms that can be generated by the AD9854 DDS and investigated techniques for synchronizing multiple DDSs. The key timing requirements were to have a coincidental reference clock between all the DDSs and a trigger signal to initiate the transfer of the programmed data to the DDSs at the same time.

Tong [7] performed a system-level analysis to establish that a distributed array radar with 400 elements could indeed achieve the required detection of above 1000 km needed for a ship-borne BMD at VHF/UHF. It also established the system performance parameters (main lobe gain, average sidelobe level and number of active elements) based on a random, aperiodic and thinned array. This type of array was expected given that the element failures would occur randomly, element locations would not be spaced evenly, and the element spacing would be more than  $\lambda/2$  due to the fact that the ship's superstructure and size would probably not allow for uniformly spaced elements. A hybrid technique for designing a U-slot microstrip patch antenna was also developed, which could aid in designing a low-profile antenna that conforms to the ship's shape.

Yong Y.C. [8] successfully demonstrated the wireless Local Oscillator (LO) distribution in which a LO signal was transmitted wirelessly to two AD8346 modulators whose amplitude and phase characteristics showed good agreement with a hardwired distribution. Digitization of the receive modules was also investigated using a 8-bit ADC which gave a resolution of only 15.6 mV in a 4 V voltage output range. It was concluded that a 16-bit ADC would be able to provide 0.06 mV resolution. Finally, two transmission structures, the parallel-plate waveguide and single conducting plate with thin dielectric film were studied for shipboard LO distribution and found to be potentially viable for use in the wireless distributed array radar concept.

Yong L. [9] investigated the problems of integrating the array elements through a wireless synchronization and found that phase synchronization of the array elements was possible with a simple synchronization circuit. It was also concluded that a position location scheme to correct for the dynamic effects of hull deflection was not necessary at VHF/UHF frequencies. Analysis found the data transmission rate needed for the wireless networked digital phased array would be about 3.7 Gb/s and a Multi-Input Multi-Output Orthogonal Frequency Division Multiplexing (MIMO-OFDM) scheme was proposed to achieve such a high data rate.

Burgstaller [2] used the Transmit/Receive (T/R) module design in [9] and did a thorough characterization of the various components (AD8346 modulator, AD8347 demodulator, Low Noise Amplifier (LNA), Low Power Amplifier (LPA), circulator and

dipole antenna). The system design of an eight-element array was proposed and a simulation performed to assess its antenna patterns.

### **C. THESIS OBJECTIVE**

This thesis focused on the hardware and software development and testing of a 2.4 GHz two-element demonstrator array. The objectives were as follows:

- Design and assemble two T/R modules. The T/R module integrates such RF components as the circulator, LNA, LPA and LO splitter, as well as the RF modulator and demodulator boards into a single chassis.
- Build a two-element array test bench integrating the Host computer with the various National Instruments (NI) hardware such as cRIO NI-9263 Analog Output and NI-9215 Analog Input modules, cRIO-9104 Reconfigurable Input/Output Chassis and Field Programmable Gate Array (FPGA) module, and cRIO-9004 Real-Time Controller.
- Develop the test software, using LabVIEW, to demonstrate the proper functionalities of transmission and reception of the T/R modules.
- Conduct measurements to characterize the performance of the T/R modules. One such measurement is to observe the occurrence of interference between the AD8346 modulator and AD8347 demodulator boards inside of the T/R module chassis, given their proximity to each other.
- Address the issues of:
  - the waveforms which can be used with the existing hardware,
  - the type of signal processing to employ,
  - the digital beamforming concept, and
  - the data rates required for the wireless network implementation and assess their impacts on the distributed array radar performance.

### **D. THESIS ORGANIZATION**

Chapter II describes the wirelessly networked distributed array radar concept and architecture.

In Chapter III, an analysis of the T/R module and system parameters such as sensitivity, noise figure, detection range and Signal-to-Noise Ratio (SNR) is done. Some key parameters pertaining to an eight-element array were calculated. The choice of waveform and its properties, signal processing, digital beamforming performance, bandwidth and data rate requirements are discussed.

Chapter IV describes the T/R module's electrical and mechanical design, the two-element array test bench set up and the associated LabVIEW software flow and code.

Chapter V then summarizes some of the timing and other measurements performed using the two-element array test bench.

Finally Chapter VI summarizes the work and recommends the areas in which further research can be focused.

## II. SYSTEM ARCHITECTURE

### A. WIRELESSLY NETWORKED DISTRIBUTED DIGITAL ARRAY RADAR CONCEPT

In the Wirelessly Networked Distributed Digital Array Radar (WNDDAR) concept, hundreds or even thousands of array elements are placed at available locations on the ship's platform. Figure 2 gives an illustration for one array element and its T/R module. The functions of the T/R module will be described in more detail later. The element antenna can be made conformal to the ship's structure to reduce the RCS and thus increase stealth.

Each array element will interact with the ship's central digital beamformer and controller unit, transmitting and receiving the required LO and digital data needed for the system operation.

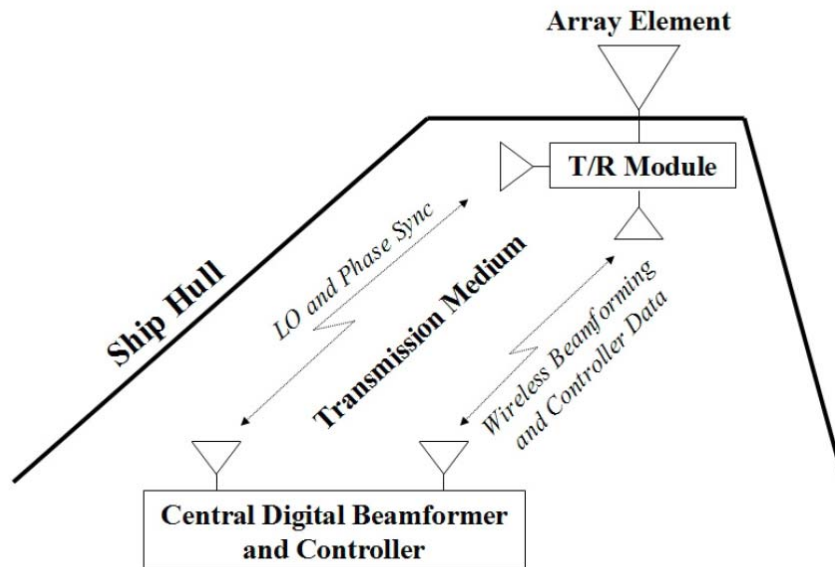

Figure 2. WNDDAR concept (From [2])

When transmitting, the central digital beamformer and controller sends the required LO signal and phase synchronization data wirelessly through the ship's interior or other transmission structure to the designated LO antenna on the T/R module. Yong Y.C. [8] has looked into various transmission structures which have the potential to

support such in-the-hull transmission with low loss and interference. The LO signal and phase synchronization data come from knowing the exact location of the particular element. Phase synchronization is done in real time to account for ship distortions and transmission channel variations.

Figure 3 shows the proposed T/R module design which has been studied for such a wireless network implementation. The beamformer and controller sends the digital waveform data wirelessly to the T/R module so that the DDS and modulator inside the T/R module sets the phase shift it has to introduce to the LO carrier, which is also received wirelessly. The DDS and modulator thus modulates the LO carrier with the required phase and passes it to the power amplifier (PA) which amplifies it and sends it to the antenna through the circulator. With all the elements synchronized, the result will be the required beam shape and scan direction from the ship.

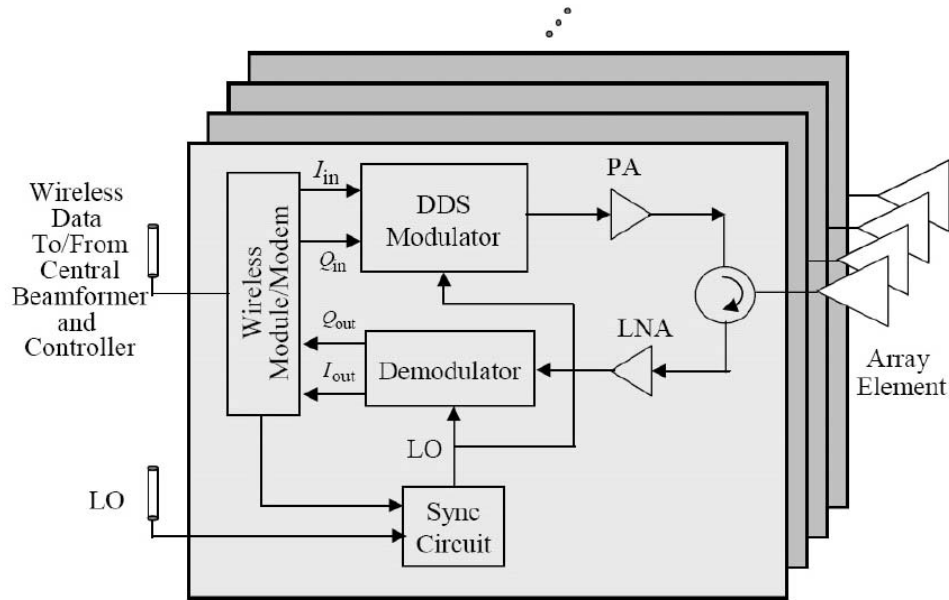

Figure 3. Block diagram of T/R module in array (From [10])

When receiving, the target echo is received by the element antenna which then relays the signal to the LNA through the other port of the circulator in the T/R module.

The signal is passed to the demodulator which extracts the baseband echo data and sends it wirelessly back to the central beamformer and controller for processing. The target's position, bearing and speed can thus be calculated.

The array elements need to be synchronized in both time and phase throughout the opportunistic array. For time synchronization, this means the transmitted or received radar signals should be timed such that they overlap at the target or array output respectively. For phase synchronization, this means the phases of the transmitted or received radar signals should be adjusted so that they arrive in phase at the target or at the output of the receiver.

A proposed communication architecture is shown in Figure 4. According to [9], the communication protocol is described next.

At regular intervals, each array element will send its Position Location Data to the central digital beamformer and controller. With knowledge of the element locations, the processor calculates the appropriate digital amplitude and phase weights to apply for each array element for digital beamforming, and broadcasts this information to all array elements in the Waveform and Control Data. The distribution of the LO signal (required by the modulator and demodulator) and the REFCLK signal (required for the DDS) are combined into a single waveform. A pulse train is transmitted from the centralized controller and the pulse train envelope detected and used for timing. The carrier can be extracted and used for the LO. Each T/R module will incorporate hardware (LO Synchronization Circuit in Figure 3) for performing the synchronization. The Phase Synchronization Control Data will be used to phase synchronize all the array elements. The amplitude and phase corrected waveform is then modulated, amplified and transmitted. On receive, echo signals are demodulated and the Target Return Data sent to the central digital beamformer and controller for processing. All data communication will be enabled by a wireless link with the capacity to network the entire opportunistic array.

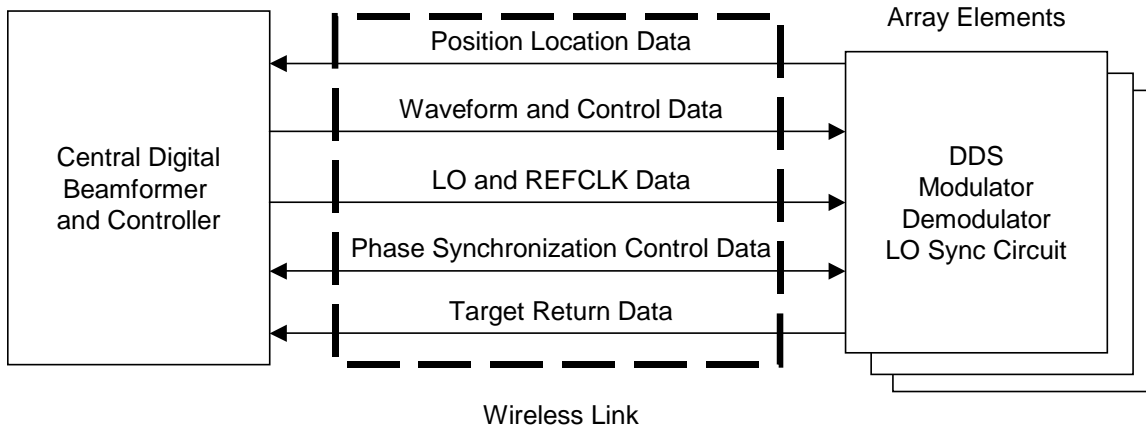

Figure 4. Proposed communication architecture for the WNDDAR (From [9])

The WNDDAR concept brings about several key enabling technologies and challenges which are described in the following sections.

## B. WIRELESS SENSOR NETWORKS

An ongoing exciting area of research is reconfigurable wireless sensor networks which are deployed for area surveillance, chemical, biological or thermal environment sensing, etc. The sensors are often compact and made expendable, i.e. non-recoverable. Thus, they usually have limited battery life and functional capability for the purpose of the mission. When functioning, each sensor node will “talk” with its neighboring nodes to acquire and correlate status and data. Depending on the networking architecture, a group of nodes can communicate with a mid-central node which then combines with other mid-central nodes to form a network with the central node. Sensor data and commands can then be passed to and from all the nodes in the network. The advantages of such a network are:

- **Increased survivability.** Not all the nodes will fail at the same time and there usually will be an overlap in the coverage of each sensor. So if one or two nodes fail, the whole network is not shut down and it can still perform the required mission.
- **Increased flexibility and reconfigurability.** Assuming the system bandwidth is not exceeded, sensor nodes can be added to or removed from the network. For example, if a particular area is not deemed a threat at the present time, the sensors covering that area can be commanded to “shut down” and conserve power until a later time.

Similarly for the WNDDAR, each array element can be considered a part of the ship's "network of sensors" and by being spread around the ship's structure, they can perform different functions as required. They can be reconfigured to compensate for element failures and battle damage by simply modifying the signal processing.

### **C. CONFORMAL AND MULTI-FUNCTION ARRAYS**

With the need to reduce the electromagnetic (EM), infra-red (IR) and optical signatures of a ship, there is a need for conformal arrays which can "blend with the ship's structure." Ongoing research areas are conformal multi-aperture sensors or "smart skins" for unmanned combat and reconnaissance air vehicles. Conformal arrays are also on air platforms such as E-10 surveillance aircraft, the E-3 AWACS and various Unmanned Aerial Vehicle (UAV) platforms [11].

With space constraints onboard a ship, there is motivation to look into systems which are multi-functional. One advantage of the digital architecture of the WNDDAR is that the phased array can be used not only for radar, but for communications, data links and even Electronic Attack (EA), where a dose of directed EM power is used to jam or disrupt enemy sensors at close range.

A recent article [11] reported the US Army is looking into electrically large arrays at Ka-band, which could both sense and communicate. Communication rate is reported to be sustainable at 10 Mbps over a range of 80 km. This actually will allow the radar to serve as a data link for the platform, including EO, IR and Synthetic Aperture Radar (SAR) imaging all at the same time.

### **D. ADVANCES IN MICROELECTRONICS AND SIGNAL PROCESSING**

A digital radar architecture has most of its signal and data processing functions implemented in the digital domain. The signal and data processing requirements are further increased with hundreds or even possibly thousands of elements in a distributed radar configuration. But continuing advances in microelectronics in terms of speed and functionality, coupled with incorporating the devices in lower cost and smaller commercial-based packages, will enable the realization of the high-performance radar signal processing needs. A brief discussion of two areas of particular interest follows.

## 1. Field Programmable Gate Arrays (FPGAs)

An FPGA is a large array of programmable logic blocks interconnected by an abundance of routing resources, and surrounded on the periphery by input/output (I/O) blocks. Because the FPGA does not require a fixed hardware structure, the connections can be reprogrammed. This allows for custom hardware to be created quickly, which increases the flexibility in software design. In [12], a FPGA-based design had the fastest execution speed in performing a 1024 point complex Fast Fourier Transform (FFT) among other top-end Digital Signal Processor (DSP) and FFT Application Specific Integrated Circuit (ASIC) devices. In addition, FPGAs have an inherent parallel architecture allowing one to execute multiple control loops simultaneously without affecting the loop's execution time. This suits well for an application such as the distributed array radar, in which many array elements need to be synchronized in executing a certain function. Figure 5 shows the role FPGA can play in the digital array radar.

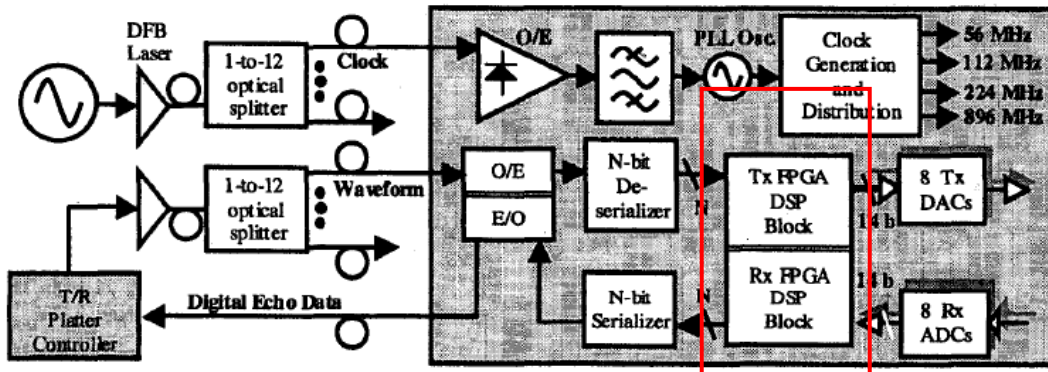

Figure 5. FPGA in a typical digital radar (From [13])

## 2. Direct Digital Synthesis (DDS)

The DDS is another key to realizing a digital T/R module. The DDS has many advantages over the analog method in that it can achieve sub-hertz resolution, continuous phase frequency switching, low phase noise, and complex waveforms and is generally more cost-effective as the signal is processed in the digital domain [14]. Being a digital method, the DDS brings about high accuracy and repeatability, which is crucial in implementing a digital array radar.

As can be seen in Figure 6, a DDS basically consists of three main parts: (1) a phase accumulator to determine the phase, (2) sine wave lookup table to determine the amplitude, and (3) a Digital-to-Analog Converter (DAC) to convert the signal into an analog form. The Low Pass Filter (LPF) helps to remove the harmonics generated.

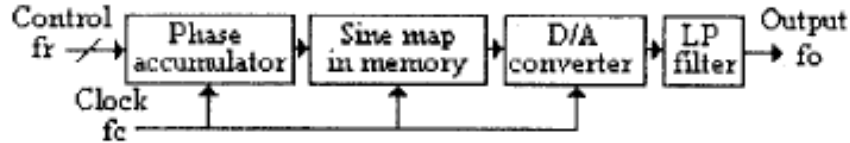

Figure 6. Block diagram of a typical DDS (From [14])

The frequency output from the synthesizer is related to the clock frequency  $f_{\text{clock}}$  and the frequency control word  $f_{\text{control}}$  by

$$f_{\text{out}} = f_{\text{clock}} \times \left( \frac{f_{\text{control}}}{2^N} \right) \quad (2)$$

where  $f_{\text{out}}$  = output frequency of the DDS,

$f_{\text{clock}}$  = internal reference clock frequency, and

$N$  = length in bits of the phase accumulator.

The frequency resolution is given by

$$f_{\text{min}} = \left( \frac{f_{\text{clock}}}{2^N} \right). \quad (3)$$

The DDS can generate both the transmit waveform and the LO for a digital phased array radar. By combining the phase control capability of the DDS with an external amplitude modulator, the non-linearities in amplitude and phase response of the T/R modules can be corrected. The DDS can also maintain quadrature phase across the Intermediate Frequency (IF) bandwidth in the baseband demodulator, which is crucial in achieving low sidelobes.

One high-performance DDS chipset is the AD9858 from Analog Devices, which has a 10-bit DAC and an internal clock rate of 1 giga samples per second (GS/s) [15].

## E. DIGITAL BEAMFORMING

A Digital Beamformer (DBF) is a processing structure which accepts signals from an array in digital form and performs spatial processing on them [16]. This covers not only classical beamforming where the signals are weighted in amplitude and phase prior to summation to produce a specific polar diagram, but also the application of non-linear signal processing algorithms such as autoregressive techniques, eigen-analysis, etc.

In classical beamforming, to generate a steerable beam from a phased array, three main functions need to be performed:

- co-phase the signals arriving at the elements of the array from the desired direction,
- apply amplitude weighting to control the spatial sidelobe structure, and
- sum the weighted co-phased signals to produce the desired beam.

A wavefront arriving from a particular direction will reach different elements of the array at different times depending on their relative positions. The most logical method of co-phasing will be to introduce variable time delays into the element outputs to compensate for the differential delays. The range of time delay  $T$  required will depend on the largest array dimension  $D$  and the maximum desired scan direction  $\theta_s$  as shown in Figure 7.

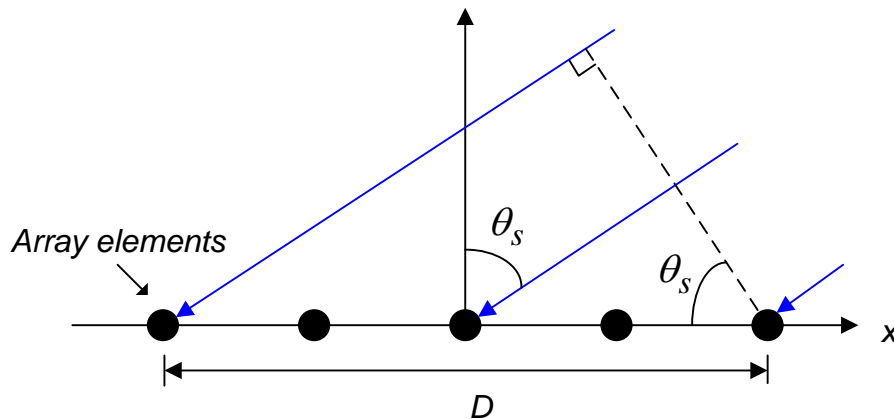

Figure 7. Time delay between array elements

Thus for a linear array along the  $x$  axis,

$$T = \frac{D}{c} \sin \theta_s \quad (4)$$

where  $c$  is the speed of light in vacuum,  $3 \times 10^8$  m/s, and  $\theta_s$  is the angle from the array broadside.

This is also known as the filling time of the aperture, i.e. the time for a step wavefront to traverse the array when incident from the maximum scan direction. It is not practical to provide beam steering via programmable time delays and if the instantaneous signal bandwidth is a small fraction of the center frequency, the time delay can be approximated by a phase shift. If the fill time is  $T$ , the frequency change is the reciprocal of  $T$ . An upper bound can then be set on the instantaneous bandwidth to be one-tenth of this [16]. That is

$$B = \frac{1}{10} \left( \frac{1}{T} \right). \quad (5)$$

Beamforming can be done at two levels:

- At carrier frequency where there are schemes such as single-fixed beam networks, multiple fixed-beam networks and scanned beam-cluster networks.
- At IF or baseband which requires a frequency converter stage with associated amplification and filtering for each element of the array. The advantage of this method is that the noise figure of the system becomes independent of the insertion loss of the beamformer and so a large number of overlapping beams can be generated, especially for bistatic operation. There are multiple fixed-beam networks and multiple agile-beam networks.

While digital beamformers tend to be more complex and require high-speed signal processing, this is deemed less a problem based on the continuing advances in microprocessor speed and size. Digital beamforming has the ability to generate multiple, independent, highly agile beams with low sidelobes [16], as well as to vary the gain and phase applied to all the elements in the array or to a set of sub-arrays. It only requires the element signals to be available in digital form and each digital sample must have both the amplitude and phase information.

A typical digital beamforming method for the receive channel is shown in Figure 8. After IF amplification, the signal from an element is split into two paths and mixed

with the LO except for a 90 degree phase difference. The video baseband outputs of the mixers are thus orthogonal in the Cartesian sense, as shown in Figure 9. Mathematically, the in-phase ( $I$ ) and the quadrature-phase ( $Q$ ) components are given by

$$I = A \cos \theta \quad (6a)$$

$$Q = A \sin \theta \quad (6b)$$

where  $A$  is the amplitude of the received signal and  $\theta$  the phase. The signal is reconstructed from  $s(t) = I(t)\cos(2\pi ft) - Q(t)\sin(2\pi ft)$ .

After further amplification and filtering, each baseband signal is passed through an anti-aliasing filter, sample-and-hold and digitized. The sampling rate is directly related to the bandwidth of the signal and the resolution of the ADC is defined by the acceptable degradation in the signal-to-noise ratio, dynamic range of the signals and type of signals.

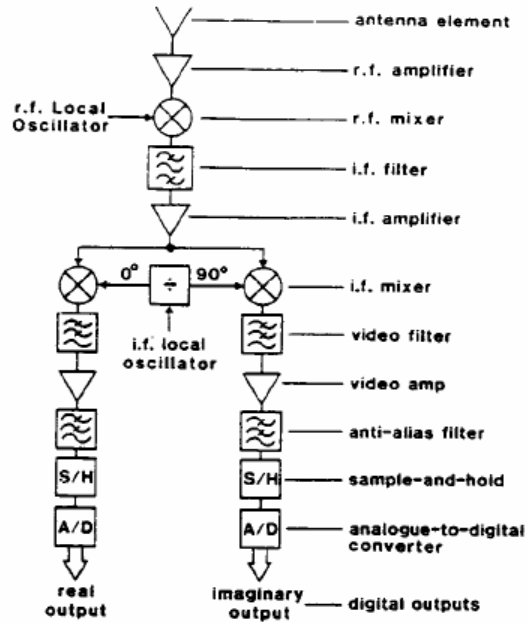

Figure 8. Digital beamforming process using IF (From [16])

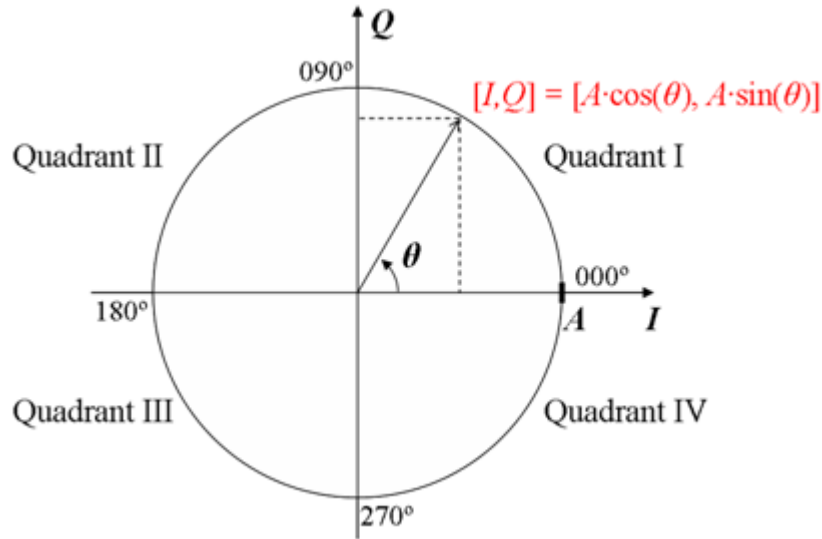

Figure 9. I-Q Conversion (From [2])

The signals are then multiplied by the appropriate set of beamforming coefficients and summed. The quadrature signal components can be treated as complex samples and the coefficients as complex coefficients and so the multiplication and summing processes are complex operations.

For the full performance of the system in terms of sidelobe level to be realized, the *I* and *Q* channels must track in gain and phase over the signal bandwidth and maintain a 90 degree phase relationship. Deviation from this means amplitude and phase errors which need to be monitored and corrected for in the signal processing, e.g. by applying the appropriate weights in the digital processor.

Current DDS technology has a limitation in sampling rate which limits the output signal frequency to the order of 500 MHz. As the WNDDAR is likely to operate in the VHF/UHF band, there is high potential for the use of a DDS without upconversion using a modulator. As shown in Figure 10, in addition to creating the required radar waveform needed, the DDS can adjust the amplitude and phase of the RF signal to be transmitted to ensure the lowest amplitude and phase errors as possible.

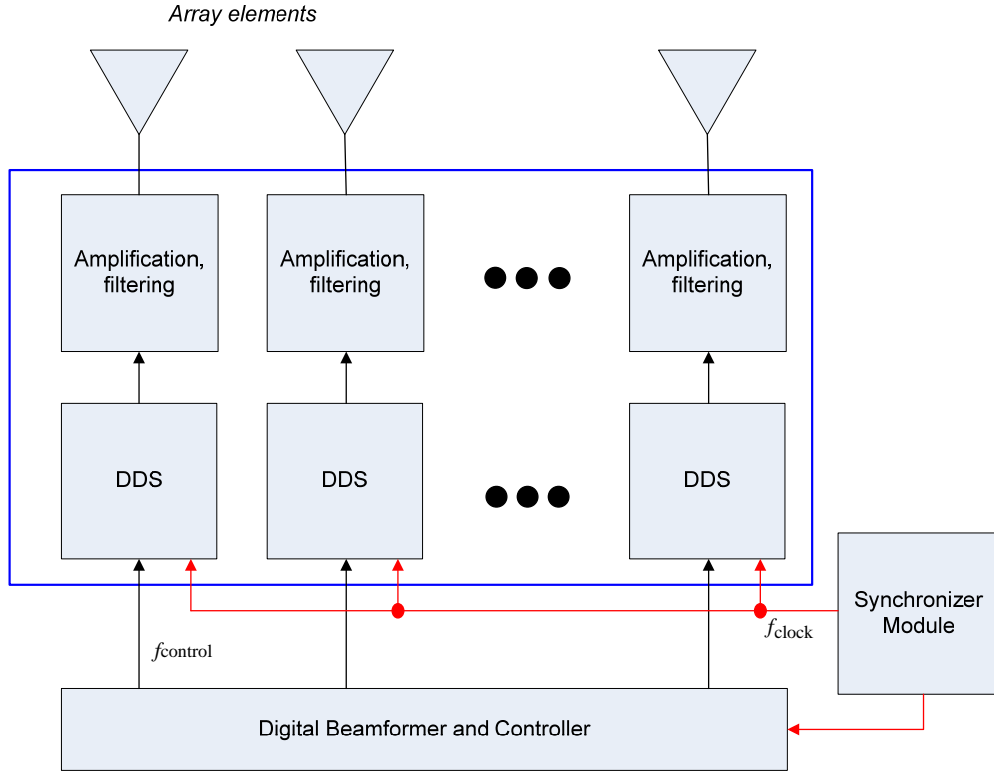

Figure 10. Digital beamforming process for a transmit array at VHF/UHF

## F. TIMING AND SYNCHRONIZATION

### 1. Wireless LO and Synchronization

For coherent operation of the radar, each element must be synchronized to the same time and phase references. The synchronization is essential to scan the beam in the required direction and perform coherent detection and integration of the echoes reaching the array. Yong, Y.C [8] was able to demonstrate the wireless LO distribution for a two-element transmit array. A LO source transmitted its signal wirelessly in an anechoic chamber to two AD8346 modulator boards. The output powers from the boards were then summed to a power meter. The results showed good agreement between the theoretical and measured LO signal phase.

For synchronization, Yong L. [9] studied a “brute force” technique which could require a simple synchronization circuit in the T/R module shown in Figure 11. During the synchronization mode shown in Figure 12, the controller sends the synchronization data to the T/R module which then programs a phase shifter to introduce a certain phase shift to the LO. The switch is moved down so that the phase-shifted LO is transmitted

back to the digital beamformer and controller. Once the phase shift is deemed correct by comparison with a reference, the controller sends data to the synchronization circuit to switch the LO back to the path to the modulator or demodulator board. This method will thus enable each element LO to have the required phase shift to produce a coherent beam.

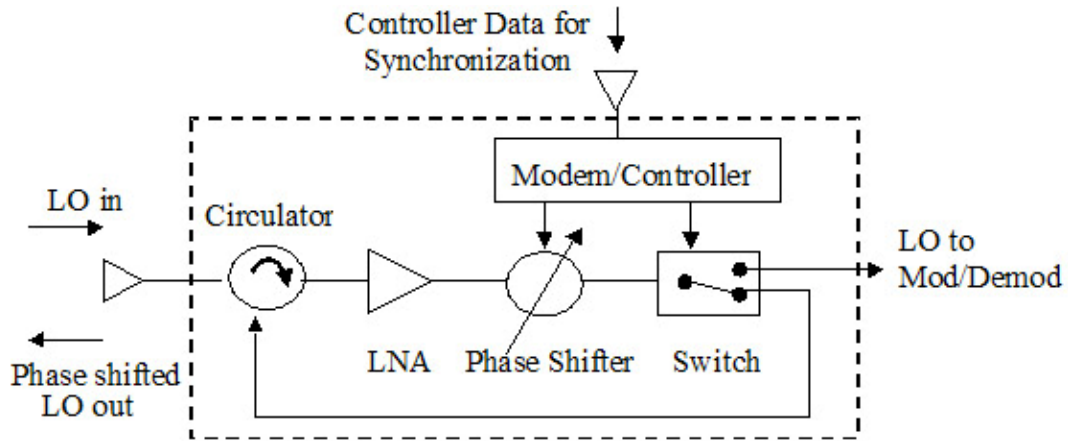

Figure 11. Diagram of possible synchronization circuit in T/R module (From [10])

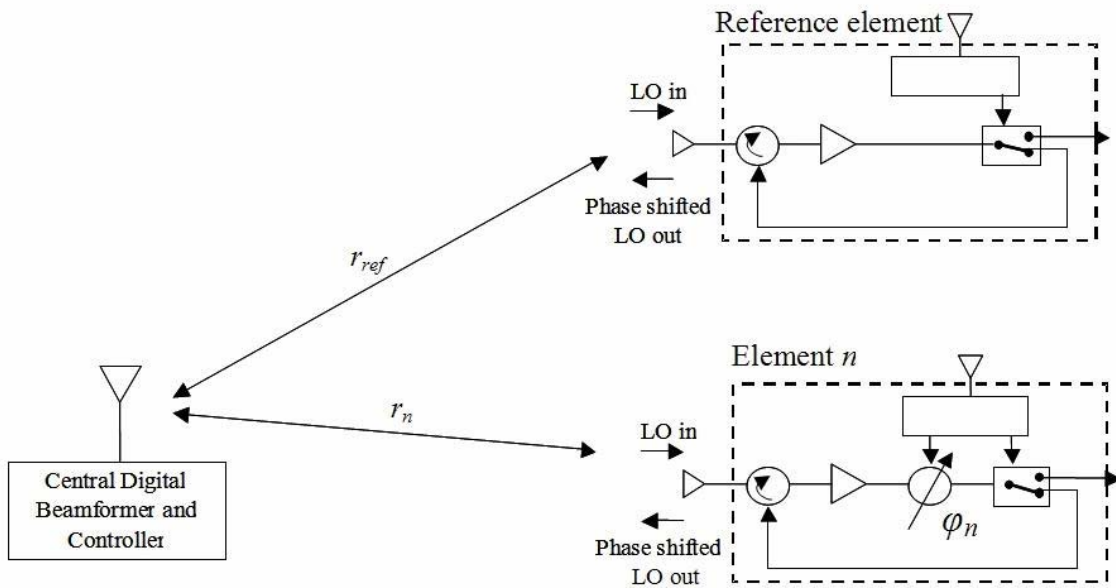

Figure 12. LO phase synchronization concept (From [10])

## **2. Element Geolocation**

As mentioned, the central digital beamformer and controller must have knowledge of the exact location of each array element so that it can provide them accurate phase information for beam scanning. Yong L. [9] established that the element positions must be determined to within a fraction of wavelength to compensate for varying phase errors which could result in degradation in sidelobe level, gain and beam steering. It was also concluded that a position location scheme to correct for the dynamic effects of hull deflection was not necessary for the intended application at VHF/UHF frequencies.

As a summary, this chapter has described the system concepts and architecture of the WNDDAR, highlighting the key technical issue of time and phase synchronization among the array elements. Critical technologies such as wireless high data rate networking, conformal arrays, FPGA and DDS technology play an important role in the successful implementation of a wireless digital distributed array radar. The next chapter discusses some key system design parameters and presents performance calculations for the T/R module and the eight-element array proposed in [2].

### III. DISTRIBUTED ARRAY RADAR DESIGN AND ANALYSIS

#### A. T/R MODULE ANALYSIS

Figure 13 shows the block diagram of the T/R module built..

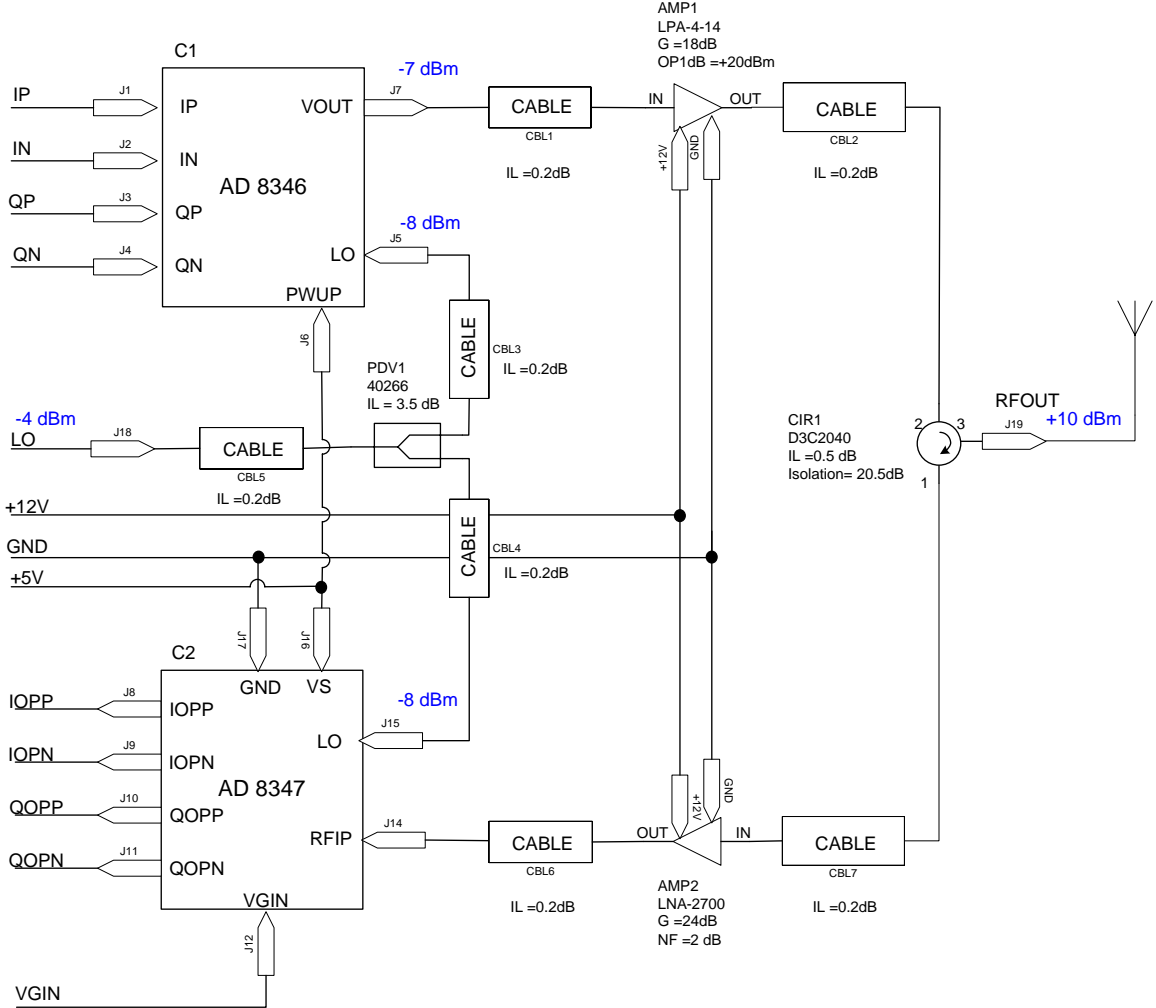

Figure 13. Block diagram of T/R module

#### 1. Receiver Noise Figure, Effective Temperature and Noise Floor

To calculate the noise figure of the T/R module, consider the receive chain. The noise figure of the T/R module is given by

$$F = F_1 + \frac{F_2 - 1}{G_1} + \frac{F_3 - 1}{G_1 G_2} + \frac{F_4 - 1}{G_1 G_2 G_3} \quad (7)$$

where

$$F_1 = \frac{1}{G_1} = \text{insertion loss of circulator and cable assembly } 7 = 0.9 \text{ dB,}$$

$$F_2 = \text{noise figure of LNA} = 2 \text{ dB,}$$

$$G_2 = \text{gain of LNA} = 24 \text{ dB,}$$

$$F_3 = \frac{1}{G_3} = \text{insertion loss of cable assembly } 6 = 0.4 \text{ dB, and}$$

$$F_4 = \text{noise figure of AD8347 demodulator} = 11.7 \text{ dB (from [17]).}$$

Thus, Equation (7) gives  $F = \mathbf{3.06 \text{ dB}}$ .

The receiver effective temperature  $T_e$  is given by

$$T_e = (F - 1)T_o. \quad (8)$$

Thus,  $T_e \approx \mathbf{297 \text{ K}}$ , assuming  $T_o = 290 \text{ K}$ .

The noise power at the T/R module input is given by

$$N_o = k_B T_e B \quad (9)$$

where  $k_B = \text{Boltzmann's constant} = 1.38 \times 10^{-23} \text{ J/K}$ , and

$B = \text{receiver noise bandwidth} = 50 \text{ MHz}$ .

Thus, Equation (9) gives  $N_o \approx \mathbf{-96.9 \text{ dBm}}$ .

## 2. Sensitivity and Dynamic Range

The maximum RF power that can be input to the T/R module without it being saturated is limited by the demodulator's input 1 dB compression point (IP1dB). From [17], the demodulator's IP1dB  $\approx -22 \text{ dBm}$  with no Automatic Gain Control (AGC). Hence, with reference to Figure 13, the maximum RF power that can be input to the T/R module is

$$P_{r_{\max}} = -22.0 + 0.4 - 24.0 + 0.4 + 0.5 = \mathbf{-44.7 \text{ dBm}}.$$

The SNR measured at the T/R module input in this case is

$$\left(\frac{S}{N_o}\right)_{\max} = -44.7 - (-96.9) = 52.2 \text{ dB.}$$

The minimum RF power that can be input to the T/R module and still be detected depends on the demodulator's sensitivity. From [17], the demodulator mixer output voltage is linear with RF input power from  $-65 \text{ dBm}$  to  $-5 \text{ dBm}$ . Hence, with reference to Figure 13, the minimum RF power that T/R module can effectively receive is

$$P_{r_{\min}} = -65.0 + 0.4 - 24 + 0.4 + 0.5 = -\mathbf{87.7 \text{ dBm.}}$$

The SNR in this case is  $\left(\frac{S}{N_o}\right)_{\min} = -87.7 - (-96.9) = 9.2 \text{ dB}$ . Thus, the dynamic range

of the T/R module is  $-44.7 - (-87.7) = \mathbf{43 \text{ dB}}$ .

### 3. Maximum Power Output of T/R Module

Burgstaller [2] established the maximum RF power that can be output from the modulator board at 2.4 GHz was about  $-6 \text{ dBm}$ . Thus, looking at the transmit chain in Figure 13, the maximum RF power output of the T/R module will be

$$P_{o_{\max}} = -6.0 - 0.4 + 18 - 0.4 - 0.5 = +\mathbf{10.7 \text{ dBm.}}$$

## B. DISTRIBUTED ARRAY RADAR ANALYSIS

Consider the distributed array radar block diagram in Figure 14 where

$R_o$  = reference range from the origin to the target,

$R_n$  = range for the  $n^{\text{th}}$  element which is transmitting,

$R_m$  = range for the  $m^{\text{th}}$  element which is receiving,

$P_{t_n}$  = transmitted power at  $n^{\text{th}}$  element,

$P_{r_m}$  = received power at  $m^{\text{th}}$  element,

$G_{o_n}$  = gain of antenna of  $n^{\text{th}}$  element,

$G_{o_m}$  = gain of antenna of  $m^{\text{th}}$  element, and

$\sigma_{mm}$  = target bistatic radar cross section (RCS).

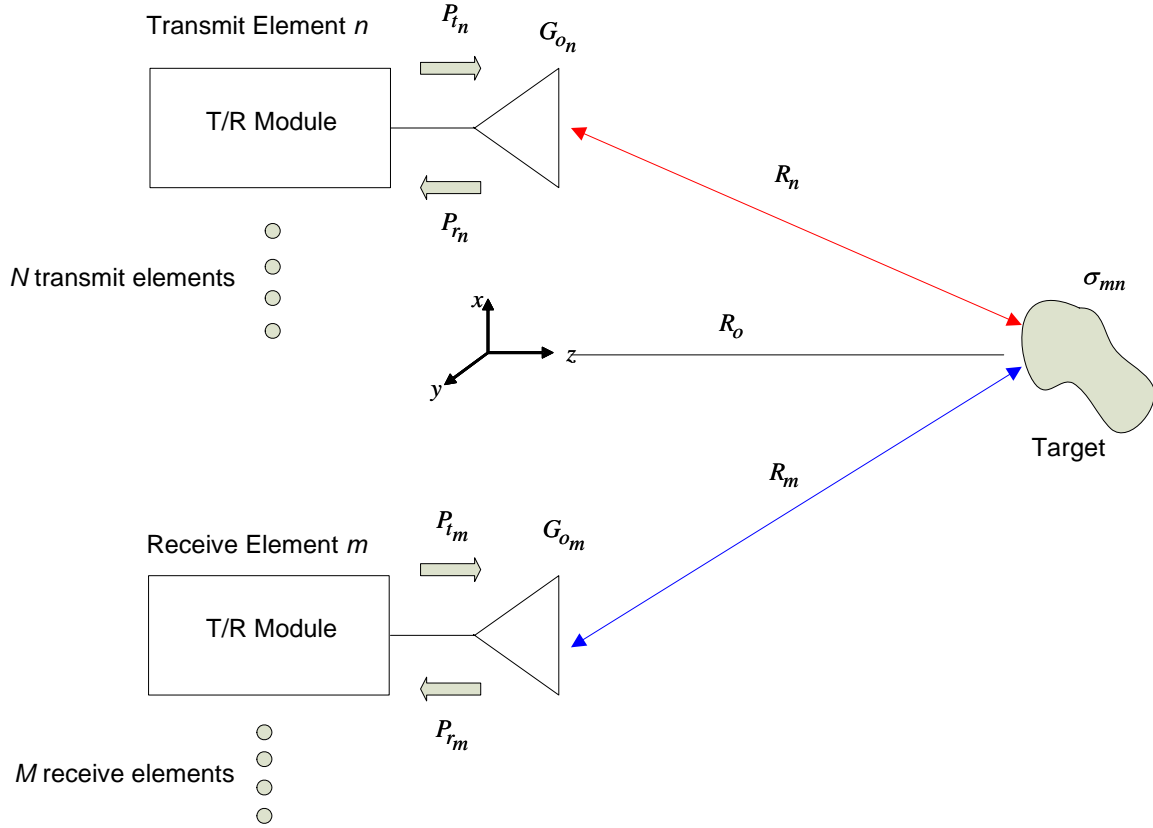

Figure 14. Distributed array radar (After [10])

At any one time,  $N$  elements may be transmitting and  $M$  elements receiving. Normally, all elements would both transmit and receive as well. In such a case,  $N = M =$  total number of elements in the array.

### 1. System Noise Temperature and Noise Factor

The system noise temperature per channel is given by

$$T_s = T_e + T_a \quad (10)$$

where  $T_e =$  receiver noise temperature = 297 K, and

$T_a =$  antenna temperature = 300 K.

Hence, Equation (10) gives  $T_s = 597$  K. The noise factor per channel is thus

$$N_o = 10 \log(k_B T_s B)$$

$$= -93.9 \text{ dBm.}$$

## 2. Radar Range Equation

From Figure 14, the total scattered electric field from the target received at element  $m$  is

$$E_m^s = \sum_{n=1}^N E_{mn}^s \quad (11)$$

where  $E_{mn}^s$  is the root-mean-squared scattered field strength from the target at receive element  $m$  due to transmit element  $n$ . It is assumed that the superposition principle applies, i.e., the total electric field at a point is the sum of the individual electric fields from other sources. Assuming that the target is in the far field of the element, the incident power density at the target when element  $n$  is transmitting is given by

$$W_n^i = \frac{P_{t_n} G_{o_n}}{4\pi R_n^2}. \quad (12)$$

The scattered power density returned to the receive element  $m$  is thus

$$W_{mn}^s = \frac{W_n^i \sigma_{mn}}{4\pi R_m^2} = \frac{P_{t_n} G_{o_n} \sigma_{mn}}{(4\pi)^2 R_n^2 R_m^2} \quad (13)$$

where  $\sigma_{mn}$  is the bistatic RCS and is shorthand notation for  $\sigma(\theta_m, \theta_n)$  where  $\theta_n$  denotes the incidence aspect angle and  $\theta_m$  the scattered aspect angle.

The peak power density is related to the electric field by

$$W_{mn}^s = \frac{|E_{mn}^s|^2}{\eta} = \frac{P_{t_n} G_{o_n} \sigma_{mn}}{(4\pi)^2 R_n^2 R_m^2}. \quad (14)$$

For free space,  $\eta = \eta_o$ , so the magnitude of the scattered electric field at receive element  $m$  is

$$|E_{mn}^s| = \sqrt{\frac{\eta_o P_{t_n} G_{o_n} \sigma_{mn}}{(4\pi)^2 R_n^2 R_m^2}}. \quad (15)$$

The phase of the electric field at receive element  $m$  is determined by the path lengths ( $R_n + R_m$ ) and any phase shift introduced by the target echo ( $\Phi_{\sigma_{mn}}$ ). Therefore,

$$E_{mn}^s = \sqrt{\frac{\eta_o P_{t_n} G_{o_n} \sigma_{mn}}{(4\pi)^2 R_n^2 R_m^2}} \exp\left\{j\left[-k(R_n + R_m) + \Phi_{\sigma_{mn}}\right]\right\} \quad (16)$$

where  $k = \frac{2\pi}{\lambda}$ .

Applying the superposition principle, the total scattered electric field received at element  $m$  from  $N$  transmitting elements is given by

$$E_m^s = \sum_{n=1}^N \sqrt{\frac{\eta_o P_{t_n} G_{o_n} \sigma_{mn}}{(4\pi)^2 R_n^2 R_m^2}} \exp\left\{j\left[-k(R_n + R_m) + \Phi_{\sigma_{mn}}\right]\right\}. \quad (17)$$

The received power is related to the electric field by

$$P_{r_m} = \frac{|E_m^s|^2}{\eta_o} A_{e_m} = \frac{A_{e_m}}{\eta_o} \left| \sum_{n=1}^N \sqrt{\frac{\eta_o P_{t_n} G_{o_n} \sigma_{mn}}{(4\pi)^2 R_n^2 R_m^2}} \exp\left\{j\left[-k(R_n + R_m) + \Phi_{\sigma_{mn}} + \psi_{mn}\right]\right\} \right|^2. \quad (18)$$

where  $\psi_{mn}$  accounts for any phase difference in the transmitted and received signals between elements  $m$  and  $n$ , as well as phase shifts added to focus and scan the beam. The beam scanning phases can be added by the transmit element  $n$  or by the receive element at  $m$ , or both.  $A_{e_m}$  is the effective antenna area of receive element  $m$ .

Finally, using the following relation between gain and effective antenna area [18]

$$A_{e_m} = \frac{G_{o_m} \lambda^2}{4\pi} \quad (19)$$

and substituting it into Equation (18), the total power received by element  $m$  is

$$P_{r_m} = \frac{G_{o_m} \lambda^2}{(4\pi)^3} \left| \sum_{n=1}^N \frac{\sqrt{P_{t_n} G_{o_n} \sigma_{mn}}}{R_n R_m} \exp\left\{j\left[-k(R_n + R_m) + \Phi_{\sigma_{mn}} + \psi_{mn}\right]\right\} \right|^2. \quad (20)$$

This is the most general form of the radar range equation for a distributed array radar. For the conventional array with identical elements, equal transmit powers, and phase focusing to achieve coherence at the target,

$$\begin{aligned}
G_{o_m} &= G_{o_n} \equiv G_o \\
P_{t_m} &= P_{t_n} \equiv P_t \\
R_n &= R_m \equiv R_o \\
\sigma_{mn} &= \sigma_o \\
\psi_{mn} &= k(R_m + R_n) \equiv 2kR_o
\end{aligned}$$

Substituting all these quantities into Equation (20) gives

$$P_{r_m} = \frac{P_t G_o^2 \sigma \lambda^2}{(4\pi)^3 R_o^4} \left| \sum_{n=1}^N (1) \right|^2 = \frac{(NP_t)(NG_o)G_o\sigma_o\lambda^2}{(4\pi)^3 R_o^4}. \quad (21)$$

This result is consistent with the radar range equation in [18]. For a conventional  $N$ -element array, the total array transmit power is  $NP_t$  and the array antenna gain is  $NG_o$ .

### 3. Signal-to-Noise Ratio and Detection Range

The SNR at element  $m$  for a focused calibrated array operating in a monostatic mode is given by

$$\left( \frac{S}{N_o} \right)_m = \frac{P_{r_m}}{N_o} = \frac{G_{o_m} \lambda^2}{(4\pi)^3 k_B T_s B} \left| \sum_{n=1}^N \frac{\sqrt{P_{t_n} G_{o_n} \sigma_{mn}}}{R_n R_m} \exp\{j[-k(R_n + R_m)]\} \right|^2. \quad (22)$$

For  $M$  receive elements in an array, if the radar uses coherent averaging of the returns from each element  $m$ , this process involves adding the amplitude of  $M$  signals from a target that have coherent phase. The associated power of coherent summation is proportional to  $M^2$ . Noise is usually assumed uncorrelated Gaussian white noise of random amplitude and phase. The noise power of  $M$  signals add to give the noise power of a single signal times  $M$ . The signal voltage adds (a factor of  $M^2$  in power) and thus, the improvement in SNR is a factor of  $M$ . Therefore, the SNR of an array is given by

$$\left( \frac{S}{N_o} \right)_{\text{array}} = M \left( \frac{S}{N_o} \right)_m. \quad (23)$$

To determine the detection range possible with an eight-element array, the following are assumed:

$$G_{o_m} = G_{o_n} = 6.6 \text{ dB} \equiv 4.57,$$

$$P_{t_m} = P_{t_n} = 10 \text{ dBm} = 0.01 \text{ W},$$

$$R_n = R_m = R,$$

$$\sigma_{mn} = 0.5 \text{ m}^2,$$

$$N = M = 8,$$

$$\lambda = 0.125 \text{ m at } 2.4 \text{ GHz},$$

$$T_s = 597 \text{ K, and}$$

$$\left( \frac{S}{N_o} \right)_m = 9.2 \text{ dB} \equiv 8.32.$$

The detection range  $R$  can be found from Equation (22) to be **62.6 m**. The short range is a consequence of operating in the unlicensed Industrial, Scientific and Medical (ISM) band which restricts the power that can be radiated.

#### 4. Waveform, Sampling Rate and Data Rate

A radar **waveform** is crucial in target detection, resolution, and range and Doppler ambiguities. If the waveform is Continuous Wave (CW), then its peak power  $P_t$  and frequency modulation will affect the radar performance. If the waveform is pulsed, then its properties such as (1) average power  $P_{\text{avg}}$ , (2) PRF  $f_p$ , (3) pulse width  $\tau$ , and (4) frequency modulation or pulse compression will be the affecting factors.

In target detection, if the receiver is designed as a matched filter, the signal-to-noise ratio, according to [19], is given by

$$\frac{S}{N'_o} = \frac{E_o}{k_B T_e} \quad (24)$$

where  $E_o$  is the energy of the received target echo and  $N'_o$  is the noise power per unit bandwidth. For a pulsed radar,  $E_o = P_t \tau$ . Thus, in order to detect a target at long distances,  $\tau$  needs to be large enough so that there is sufficient energy returned from the target.

In terms of resolution, for a pulsed radar, the range resolution is determined by

$$\Delta R = \frac{c\tau}{2}. \quad (25)$$

Thus, the shorter  $\tau$  is, the better the radar will be in resolving two targets separated in distance.

If the receiver bandwidth  $B$  is 50 MHz as assumed earlier, then for matched filter response,  $B\tau \approx 1$  should be observed. This would give a  $\tau$  of about **20 ns**. This may not be achievable with the current National Instruments hardware, as the resolution is about 25 ns from the FPGA clock rate of 40 MHz. This resolution also implies that the range resolution is at best 3.75 m, from Equation (25). While this should not be a problem for the eight-element array, the full-scale array is likely to require better range resolution and so a higher performance solution will need to be sought for.

The PRF of a pulsed radar is important in determining the extent that the radar suffers from range and Doppler ambiguities. The higher the PRF of the waveform, the more range ambiguous the radar will be and the lower the PRF, the more Doppler ambiguous the radar will be. The maximum unambiguous range is given by

$$R_{un} = \frac{c}{2f_p}. \quad (26)$$

For a pulsed radar, peak transmitted power is related to the average power by  $P_t = \frac{P_{avg}}{\tau f_p}$ . Assuming the same pulse waveform characteristics for each element  $m$ , the single-pulsed SNR for an element  $m$  in the distributed array then becomes

$$\left(\frac{S}{N_o}\right)_1 = \frac{P_{avg} G_{o_m} \lambda^2}{(4\pi)^3 k_B T_s B \tau f_p} \left| \sum_{n=1}^N \frac{\sqrt{G_{o_n} \sigma_{mn}}}{R_n R_m} \exp\{j[-k(R_n + R_m)]\} \right|^2. \quad (27)$$

For  $N_p$  pulses, assuming coherent integration, the SNR per element will be improved by  $N_p$  [19]. The SNR of an array of  $M$  elements operating in pulsed mode will then be

$$\left(\frac{S}{N_o}\right)_M = MN_p \frac{P_{avg} G_{o_m} \lambda^2}{(4\pi)^3 k_B T_s B \tau f_p} \left| \sum_{n=1}^N \frac{\sqrt{G_{o_n} \sigma_{mn}}}{R_n R_m} \exp\{j[-k(R_n + R_m)]\} \right|^2. \quad (28)$$

The **sampling rates** of the DAC in the NI-9263 Analog Output module and the ADC in the NI-9215 Analog Input module are both 100 kS/s. From discussions with NI application engineers, the maximum frequency of a periodic analog signal that can be generated or detected is recommended to be a factor of 10 below that, meaning 10 kHz. From Equation (26), this implies an unambiguous range of 15 km. While this is good enough for the eight-element array, the full-scale array will have to operate at a PRF of

150 Hz or less to achieve an unambiguous detection range of 1000 km or more. At such a low PRF, in order to transmit with the same energy to achieve the SNR at the required detection range, either the peak power of the transmitter or the pulse width has to be increased. The first option may not be favorable as it brings about bulkier devices and heat handling issues, while the second option results in a tradeoff in the minimum range of the radar, as a wider pulse width  $\tau$  means the receiver is turned on at a later time than before.

From [19], sampling loss occurs when the video signal is sampled and digitized by the ADC. This is the difference between the sampled value and the maximum pulse amplitude. For probabilities of detection of 0.90 and false alarm of  $10^{-6}$ , Skolnik [19] states that the sampling loss is 2 dB if sampling once per pulse width and 0.5 dB for two samples per pulse and 0.2 dB for three samples per pulse. The number of samples per pulse  $N_s$  is related to the sampling rate  $f_{\text{sampling}}$ , duty cycle  $DU$  and PRF  $f_p$  by

$$N_s = f_{\text{sampling}} \times DU \times \frac{1}{f_p}. \quad (29)$$

Thus, with a sampling rate of 100 kS/s, to keep the sampling loss low with at least three samples per pulse, the ratio of  $DU$  to  $f_p$ , which is  $\tau$ , should not be lower than  $3 \times 10^{-5}$  s. A PRF of 1 kHz and 10% duty cycle, which is used in the testing of the T/R module in Chapter V, gives  $100 \times 10^3 \times 0.10 \times \frac{1}{1 \times 10^3} = 10$  samples per pulse.

For the array's **data rate** requirement, while [9] had identified a total of eight bits for waveform control, phase weighting and phase synchronization commands, the data rate the array has to handle will be dominated by the high resolution of the ADC or DAC. In the demonstrator described in Chapter IV, the National Instruments' NI-9263 module has a four-channel DAC while the NI-9215 module has a four-channel ADC, each sampling simultaneously at 100 kS/s with a resolution of 16 bits. As each T/R module has one NI-9263 and one NI-9215, the bit rate per element, therefore, is expected to be  $100 \times 10^3 \times 16 \times 8 = \mathbf{12.8 Mbps}$ . For an eight-element array, the central beamformer and controller needs to handle a total data rate of  $8 \times 12.8 \text{ Mbps} = \mathbf{102.4 Mbps}$ . Hence, a solution proposed by [9] to use commercially available IEEE 802.11g standard or "Wi-

Fi” wireless access points may not be possible as they only support data rates up to 54 Mbps. Demonstration of the wireless communication and synchronization may have to be done on a smaller array, e.g. a four-element array, which requires a data rate of 51.2 Mbps. Other options include selective scheduling of the transmit and receive data exchange so that both processes do not occur simultaneously, or reducing the amount of data that needs to be sent by local processing at the controller in the T/R module.

The dynamic range, in dB, of an ADC is given by  $20\log(2^{N_b} - 1)$  where  $N_b$  is the number of bits of the ADC [20]. Thus, for the NI-9263 and NI-9215, the dynamic range is **96.3 dB**. This is well above that of the T/R module whose dynamic range is 43 dB as determined earlier.

### 5. Digital Beamformer (DBF) Performance

As mentioned in Chapter II, a generic DBF is made up of an array of (1) antenna elements, (2) T/R modules, (3) ADC and DACs, (4) a digital beamformer, (5) a controller which is a programmable processor with software-coded algorithms, and (6) a calibration unit which matches all the channels to achieve low sidelobes. The digital beamformer usually takes the form of a very fast parallel processor capable of billions of operations per second. It forms multiple beams by finding the inner product of the set of received signal samples (in the example of DBF for receive) and the sets of weights generated by the controller. These weights are calculated in the controller based on the required scan direction needed. The computational load depends on the control algorithm implemented.

According to [21], the following parameters are important for a digital beamformer:

- Dynamic Range (DR),
- Instantaneous bandwidth  $B$ , and
- Number of complex operations per second (COPS) performed by the DBF.

The DR of a digital beamformer depends on (1) the number of bits in the ADC  $N_b$ , (2) the number of parallel elements  $N_e$ , and (3) the quantization noise. The DR is given by  $6N_b + 10\log N_e$ . Thus, for the eight-element array prototype using the 16-bits resolution ADCs,  $N_b = 16$  and  $N_e = 8$ , the expected **DR** of the (receive) digital beamformer is **105.0 dB**.

From Equation (5), the instantaneous bandwidth for the digital beamformer for the eight-element array is calculated to be about 90 MHz. This result is based on a maximum scan direction  $\theta_s$  of 45 degrees and array length  $D$  of 0.455 m (eight elements with an inter-spacing of 65 mm). This should be well above what is needed for laboratory testing purpose where the waveforms are relatively simple (CW, pulsed CW or linear frequency modulated). In addition, if the wireless communication and synchronization is carried out with the Wi-Fi devices, their bandwidths are limited to about 20 MHz.

The number of COPS a DBF must handle is given by  $N_e B$ . Thus, with  $B = 50$  MHz and  $N_e = 8$  for an eight-element array, the DSP in the DBF must achieve a computational power of  $8 \times 50 \times 10^6 = \mathbf{400 \text{ million COPS}}$ .

## 6. Transmitter Leakage

Transmitter leakage refers to the signal that travels directly from the transmit channel to the receive channel. It needs to be addressed as it concerns the choice of CW or pulsed waveform operating parameter. Figure 15 shows the block diagram of the front end of a typical radar. During transmission, the radar signal travels through the circulator and to the antenna before it is being radiated. Upon hitting a target far away, the target echo is now received by the antenna and is relayed to the receiver (Path 1a-1b). Mathematically, using the notation described in [19], the time-delayed complex signal representation of the target return can be expressed as

$$S_1 = A |S_{32}| |S_{13}| p(t - 2T_R) \exp \left[ j(2\pi ft - 2kR + \Phi_{32} + \Phi_{13} + \Phi_{\text{ant}}) \right] \quad (30a)$$

where

$A$  = amplitude factor that combines the effect of antenna gain, path loss to and from the target, target RCS fluctuations, etc.,

$|S_{32}|$  = the low-loss amplitude response from port 2 to 3 of the circulator,

$|S_{13}|$  = the low-loss amplitude response from port 3 to 1 of the circulator,

$T_R$  = the time delay to the target,

$R$  = the distance to the target,

$\Phi_{32}$  = the phase shift from port 2 to 3 of the circulator,

$\Phi_{13}$  = the phase shift from port 3 to 1 of the circulator, and

$\Phi_{\text{ant}}$  = the phase shift contributed by the antenna.

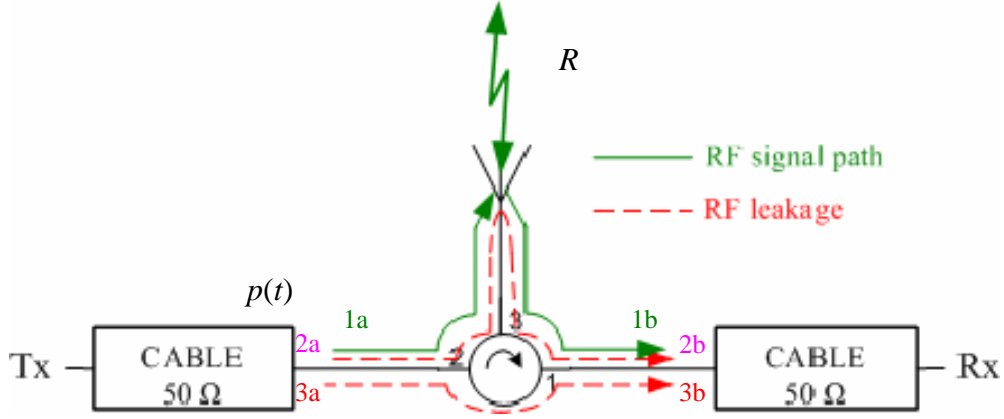

Figure 15. Target return vs. reflected and reverse leakage (After [2])

However, this desired echo which contains amplitude and phase information about the target, has to compete with two other signals. The first one, denoted by Path 2a-2b, is the part of the transmitted radar signal which travels through port 2 to 3 of the circulator but is reflected due to the antenna mismatch back towards port 1 of the circulator at the receive end. The complex signal representation of the antenna mismatch component can be expressed as

$$S_2 = |S_{32}| |S_{13}| |\Gamma_{\text{ant}}| p(t - T_2) \exp \left[ j(2\pi ft - kR_2 + \Phi_{32} + \Phi_{13} + \Phi'_{\text{ant}}) \right] \quad (30b)$$

where

$|\Gamma_{\text{ant}}|$  = the magnitude of the reflection coefficient of the antenna,

$T_2$  = the time delay through path 2,

$R_2$  = length of path 2, and

$\Phi'_{\text{ant}}$  = the phase of the reflection coefficient of the antenna.

The other signal, denoted by Path 3a-3b, is the transmitter leakage which travels directly from port 2 to port 1 of the circulator and to the receiver. The complex signal representation of the reverse leakage can be expressed as

$$S_3 = |S_{21}| p(t - T_3) \exp \left[ j(2\pi ft - kR_3 + \Phi_{21}) \right] \quad (30c)$$

where

$|S_{21}|$  = the reverse isolation from port 2 to 1 of the circulator,

$T_3$  = the time delay through path 3,

$R_3$  = length of path 3, and

$\Phi_{21}$  = the phase shift from port 2 to 1 of the circulator.

To assess the impacts of  $S_2$  and  $S_3$ , the following component data were extracted from the measurements done by Burgstaller [2] (the phase data have been ignored for simplicity):

$$|S_{32}| = 0.447 \text{ dB loss} \equiv 0.902,$$

$$|S_{13}| = 0.448 \text{ dB loss} \equiv 0.902,$$

$$|S_{21}| = 19.73 \text{ dB isolation} \equiv 0.0106, \text{ and}$$

$$|\Gamma_{\text{ant}}| = 0.18.$$

If the original transmitted signal  $p(t)$  is normalized with unit magnitude and zero phase shift, then the following results are obtained:

$$|S_1| = A(0.902)^2 = 0.814A.$$

$$|S_2| = (0.18)(0.902)^2 = 0.146.$$

$$|S_3| = 0.0106.$$

To calculate  $A$ , which is the amplitude loss factor due to the antenna gain, two-way path loss, target RCS fluctuations etc, the simplified radar range equation in [19] can be applied:

$$P_r = \frac{P_t G_t G_r \sigma \lambda^2}{(4\pi)^3 R^4} \quad (31)$$

where  $P_t$  = peak power transmitted,

$P_r$  = power received at the antenna,

$G_t$  = gain of transmit antenna = 6.6 dB  $\equiv$  4.57,

$G_r$  = gain of receive antenna = 6.6 dB  $\equiv$  4.57,

$$\sigma = 0.5 \text{ m}^2,$$

$$\lambda = 0.125 \text{ m, and}$$

$$R = 62.6 \text{ m.}$$

Thus,  $A^2 = \frac{P_r}{P_t} = 5.35 \times 10^{-12}$  from Equation (31). Hence,  $A = 2.31 \times 10^{-6}$ .

The above result shows the antenna mismatch component will be dominant if the receiver is on during transmission. In addition, the ratio of the unwanted signals to the wanted target return,  $\frac{S_2 + S_3}{S_1}$ , can be simplified to  $\frac{|S_2| + |S_3|}{|S_1|}$ . This gives a ratio of 83,283 or 49.2 dB. If the target return needs to be 10 dB higher than the mismatch and reverse leakages, then the latter need to be suppressed by almost 60 dB. Several approaches to solve this problem are described in greater detail in Chapter VI.

As a summary, this chapter has analyzed some of the key T/R module parameters such as noise figure, sensitivity, maximum output power, etc. They are tabulated in Table 1. On the distributed array system level, the SNR of a single element and the array as a whole were derived, the results of which were consistent with the standard radar range equation. In addition, key parameters, such as waveform, digital beamformer performance, sampling rate and data rate requirements, were analyzed for an eight-element array. The results are summarized in Table 2.

Parameter	Performance
Bandwidth	50 MHz
Noise output power	-96.9 dBm
Noise figure	3.06 dB
Noise temperature	297 K
Max. RF input power	-44.7 dBm giving SNR of 52.2 dB
Sensitivity	-87.7 dBm giving SNR of 9.2 dB
Dynamic range	43 dB
Max. RF output power	+10.7 dBm

Table 1. Summary of performance analysis of the T/R module

<b>Parameter</b>	<b>Performance/Requirements</b>
Bandwidth	50 MHz (may be limited to 20 MHz if using Wi-Fi devices)
Noise output power	-93.7 dBm
Noise temperature	597 K
Detection range	62.6 m
PRF and Duty cycle	Keep $\frac{DU}{f_p}$ or $\tau$ above $3 \times 10^{-5}$ s to maintain at least 3 samples per pulse
Data rate	102.4 Mbps
Computational power of DBF	400 million COPS

Table 2. Summary of performance/requirement analysis of an eight-element array

## IV. HARDWARE AND SOFTWARE DEVELOPMENT

### A. ELECTRICAL DESIGN OF T/R MODULE

This section describes the details of the electrical design of the prototype T/R module. Figure 16 shows the block diagram schematic. Burgstaller [2] has done a thorough characterization of the various components such as the circulator, low noise amplifier, low power amplifier, AD8346 modulator evaluation board and AD8347 demodulator evaluation board. The remaining items to characterize are the interconnecting RF cable assemblies and the 1:2 power splitter used to split the incoming LO into two equal signals, one for the modulator board and the other for the demodulator board. All the components are then integrated into a chassis to form a complete T/R module. For the purpose of testing, the baseband  $I$  and  $Q$  data signals are still hardwired to the various components. A component list is given in Table 3.

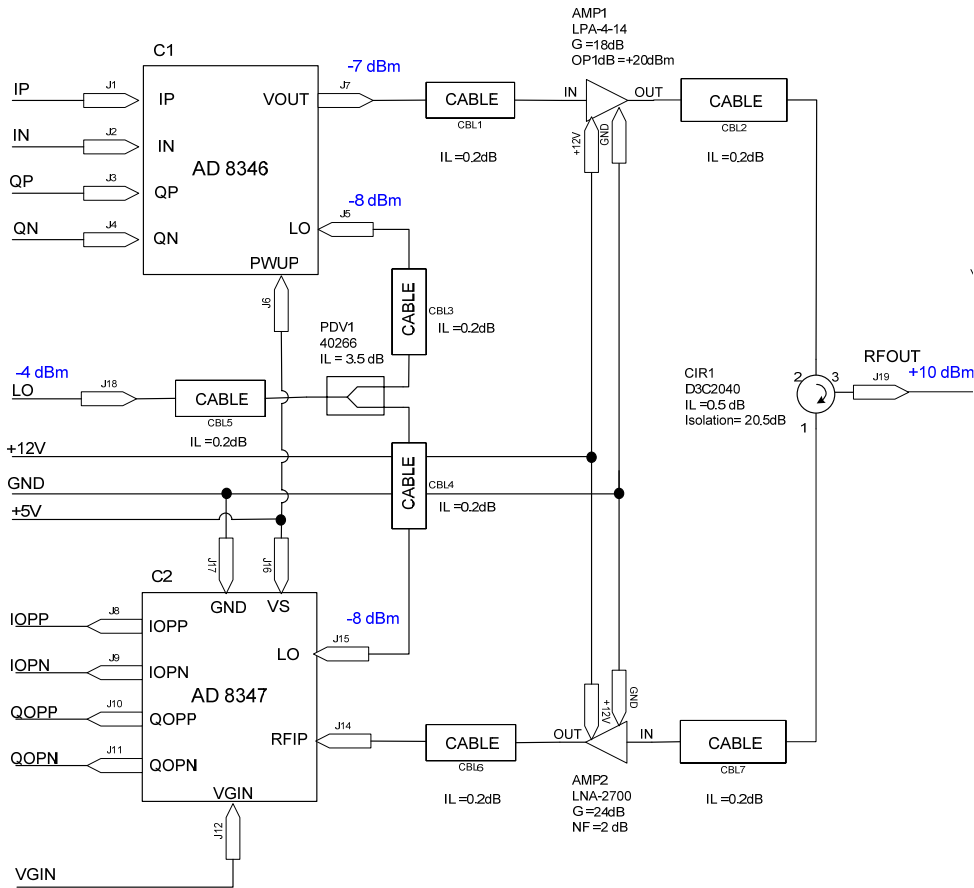

Figure 16. Schematic of T/R module

S/N	Designation	Part Number	Manufacturer
1	C1	AD8346 EVAL	Analog Devices
2	C2	AD8347 EVAL	Analog Devices
3	AMP1	LPA-4-14	RF Bay Inc
4	AMP2	LNA-2700	RF Bay Inc
5	PDV1	40266	Anaren
6	CIR1	D3C2040	DITOM Microwave Inc

Table 3. RF component list of T/R module

### 1. Power Divider

The power divider from Anaren, part no. 40266 [22] operates in the frequency range 2 to 4 GHz. Table 4 gives a summary of the parameters of the device. The amplitude and phase balance plots are given in Figures 17 and 18 respectively.

S/N	Parameter	Result (at 2.4 GHz)
1	Input port VSWR	1.07
2	Output port 1 VSWR	1.07
3	Output port 2 VSWR	1.05
4	Insertion loss S31	-3.04 dB
5	Insertion loss S21	-3.07 dB
6	Amplitude balance	0.02 dB
7	Phase balance	0.76 deg

Table 4. Summary of performance of power divider

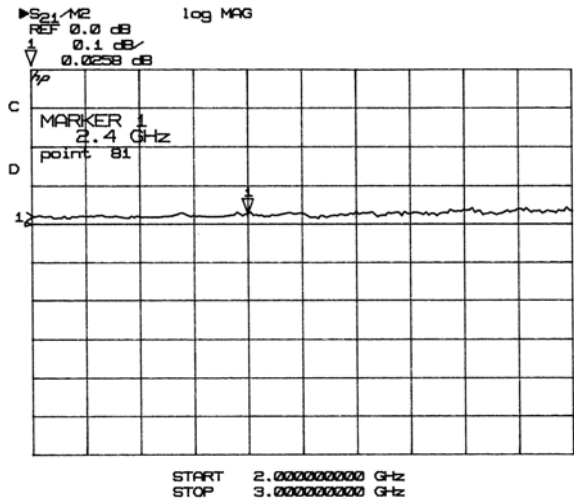

Figure 17. Amplitude balance of power divider

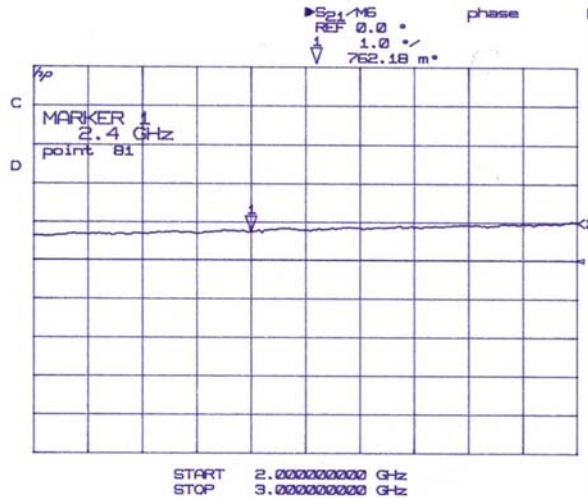

Figure 18. Phase balance of power divider

## 2. RF Cable Assemblies

The interconnecting RF cables are self-assembled using the various jigs provided by the Microwave Laboratory. The connector at each end can be either a SMA male straight plug (part no. 901-9501-3 [23]) or a right angled connector (part no. 901-9521-3 [23]) from Amphenol. The RF cable type is RG-316.

Figure 19 shows a typical S21 insertion loss and phase measurements on one such RF cable assembly. The average insertion loss is about 0.4 dB at 2.4 GHz. Table 5 gives the detailed RF cable assembly definitions.

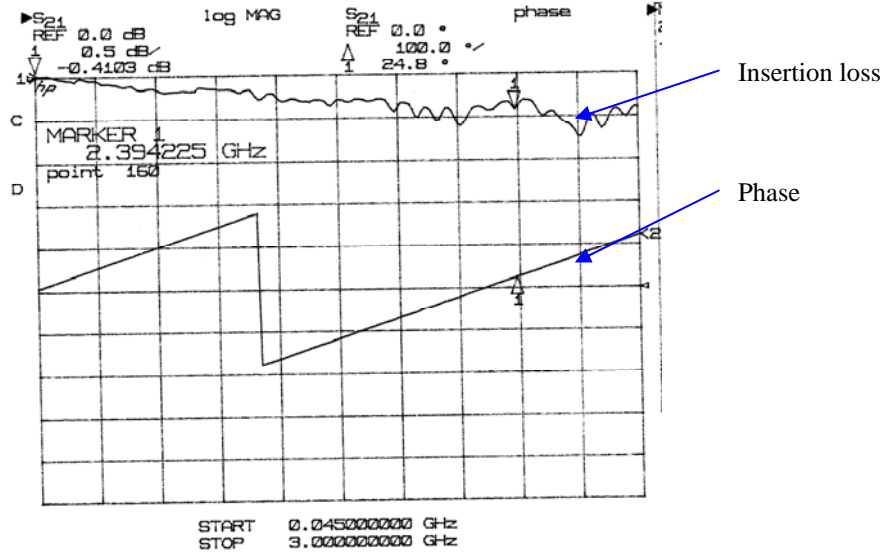

Figure 19. Insertion loss and phase measurements of RF cable assembly

Cable Assy No.	In	Out	From	To	Length (mm)
1	SMA-M right angle	SMA-M straight	Modulator Vout	AMP1 In	140
2	SMA-M straight	SMA-M right angle	AMP1 Out	CIR1 Port 2	170
3	SMA-M right angle	SMA-M right angle	PDV1 Output 1	Modulator LO	180
4	SMA-M right angle	SMA-M right angle	PDV1 Output 2	Demodulator LO	180
5	SMA-M right angle	SMA-M right angle	T/R module LO port	PDV1 Input	120
6	SMA-M straight	SMA-M right angle	AMP2 Output	Demodulator RFIP	150

Table 5. Definition of RF cable assemblies used in T/R module

### 3. Optimum AD8346 and AD8347 Settings

Burgstaller [2] investigated the performance of the AD8346 and AD8347 boards and concluded the following:

- i. The modulator differential control signals should be DC-biased to approximately 1.2 V. That means, the differential  $I/Q$  channel baseband inputs should be calculated using the following relations:

$$\begin{aligned}
 IP(\theta) &= 1.2 + \frac{1}{2}I(\theta) \\
 IN(\theta) &= 1.2 - \frac{1}{2}I(\theta) \\
 QP(\theta) &= 1.2 + \frac{1}{2}Q(\theta) \\
 QN(\theta) &= 1.2 - \frac{1}{2}Q(\theta)
 \end{aligned} \tag{32}$$

where  $I(\theta)$  and  $Q(\theta)$  were defined in Equation (6).

- ii. VGIN to the AD8347 should be set to about 0.38 V to provide the largest  $I-Q$  circle without distorting the differential outputs.

## B. MECHANICAL DESIGN OF T/R MODULE

This section describes the mechanical design of the T/R module. The mechanical chassis is a 8 inch by 4 inch by 2 inch aluminum box from Digi-Key. All the components selected were then integrated into the chassis as shown in Figure 20.

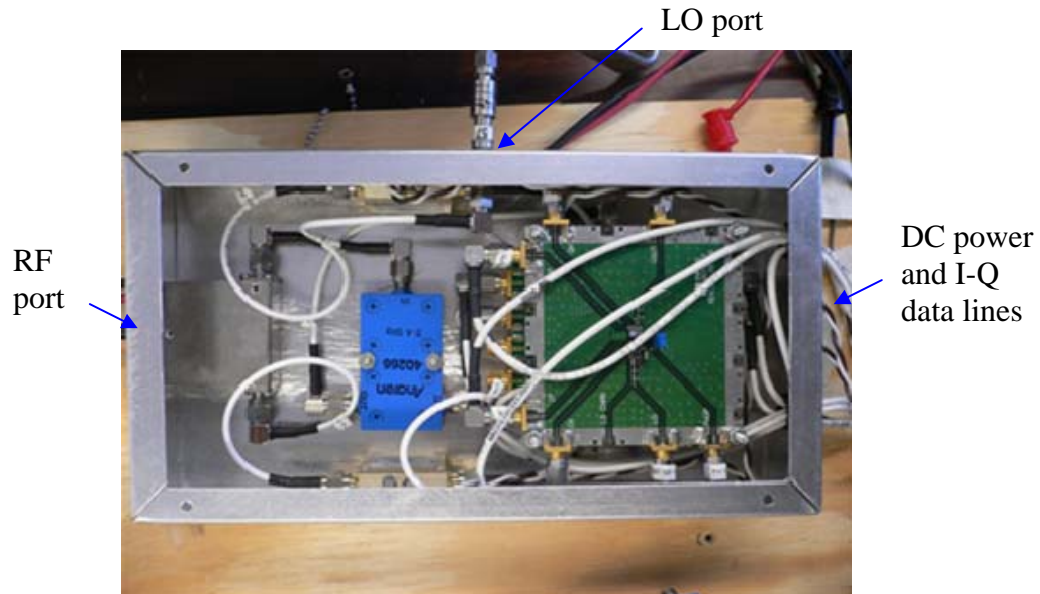

Figure 20. Assembled T/R module

Note that in order to provide minimum stress to the RF connectors, most of the cable assemblies are longer than the shortest length so as to provide some flex. The LNA and LPA are as closely mounted to the wall as possible so that there is adequate heat dissipation. The pins of the AD8346 EVAL board are separated from those on the AD8347 EVAL board by spacers. All the  $I$  and  $Q$  data lines and DC power lines go in and out of the T/R module from the back end. Table 6 gives the screw definition.

S/N	Designation	Component	Screw type	Qty	Remarks
1	C1	AD8346	#4-40	4	With nuts
2	C2	AD8347	#4-40	4	With nuts
3	AMP1	LPA 4-14	#4-40	4	
4	AMP2	LNA-2700	#4-40	4	
5	CIR1	D3C2040	#2-56	3	
6	PDV1	40266	#4-40	2	With nuts

Table 6. Definition of screws used in T/R module

## C. CONTROLLER AND DATA ACQUISITION SYSTEM

### 1. cRIO Embedded System

The hardware for controlling the TR module for performing signal processing and digital beamforming is provided by National Instruments' Compact Reconfigurable Input Output (cRIO) modules. The cRIO Embedded System consists of C series I/O modules, a Reconfigurable Chassis containing the FPGA and a Real-Time Controller capable of performing deterministic floating point calculations. Figure 21 shows the hardware which will be described in more detail in the following sections.



Figure 21. cRIO modules (From [2])

## **2. cRIO Reconfigurable Chassis and Controller**

The NI-9104 eight-slot Reconfigurable Chassis [24] is the heart of the cRIO system because it contains the reconfigurable I/O core. The RIO FPGA core, which has an individual connection to each I/O module, is programmed with elemental I/O functions to read or write signal information from each module. Because there is no shared communication bus between the RIO FPGA core and the I/O modules, I/O operations can be precisely synchronized to 25 ns resolution, with the hardware clock rate at 40 MHz [24].

The RIO core is connected to the cRIO Real-Time Controller cRIO-9004 through a Personal Communications Interface (PCI) bus interface. The cRIO-9004 [25] has 64 MB of Dynamic Random Access Memory (DRAM) memory and 512 MB of non-volatile flash storage for data logging applications. Typical functions include retrieving data from any control or indicator on the front panel of the FPGA application and performing single point control, waveform analysis, data logging and Ethernet or serial communications.

The LabVIEW FPGA module is used to program the FPGA on the cRIO reconfigurable chassis and includes powerful, ready to use, fixed-point functions to process signals directly on the FPGA. It was reported in [26] that large waveforms with up to 8192 16-bit samples can be loaded to the FPGA core, thus allowing for high resolution waveforms.

## **3. NI-9263 Analog Output Module**

The NI-9263 Analog Output (AO) Module [27] is an industrial-grade module which connects directly to the RIO FPGA core and can output the required voltage waveform to the external device. It has 4 channels per module, but each channel has its own DAC allowing for simultaneous analog output. The resolution is 16-bit and the simultaneous update rate is 100 kS/s per channel.

## **4. NI-9215 Analog Input Module**

The NI-9215 Analog Input (AI) Module [28] is an industrial-grade module which connects directly to the RIO FPGA core and acquires the signals, performs signal conditioning and communicates the digital signals to the FPGA. It has 4 channels per module, each channel having 16-bit resolution and a 100 kS/s simultaneous update rate.

## 5. Software Model

Figure 22 shows the software model. In the test bench set up, the host computer acts as the digital beamformer and controller. It runs the Microsoft Windows Operating System as well as National Instruments' application software LabVIEW. The latter will enable the user to program Virtual Instruments (VIs) which will enable the host computer to transfer commands and data to and from the FPGA hardware in the digital T/R module. Thus, a FPGA interface VI is created in the host computer and a FPGA VI created and downloaded to the FPGA hardware.

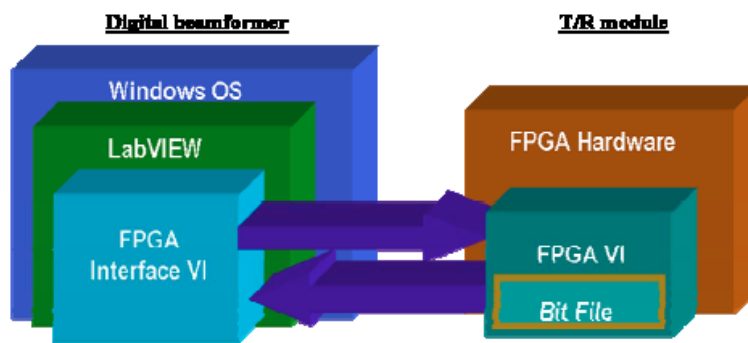

Figure 22. Software model (From [2])

## 6. Arbitrary Waveform Generation

Some effort was made in evaluating an arbitrary waveform generator example program given in [26]. Using the FPGA module, the program was able to help the hardware perform the following functions:

- Write data to the FPGA memory,
- Read data from the FPGA memory,
- Output the data to an analog output channel (the NI-9263 for example), and
- Allow the user to adjust the waveform frequency and amplitude while the signal is continuously output.

For the program to work, the user has to have the data written in a specific format and saved as a LabVIEW Measurement file which the example program can call. Alternatively, NI has an Analog/ Digital Waveform Editor software which helps the user to create arbitrary waveforms more easily with its interactive tools. The waveforms can be saved in a binary or ASCII format which the Read File routine will be able to access.

While some time and effort need to be invested in troubleshooting the example program, this arbitrary waveform generation function could be built into the array demonstrator in future so that there is a DDS capability which allows for more complex waveforms like pulse compression or chirp waveforms to be experimented with.

#### **D. TWO-ELEMENT ARRAY DEMONSTRATOR TEST BENCH**

The proposed test bench is shown in Figure 23. An external LO source [29] provides a signal at frequency 2.4 GHz and power of about +3 dBm. A two-way power divider splits the LO signal into two equal signals, each fed to the LO port of the two T/R modules. A 3 dB attenuator is placed at each LO port so that the final LO power reaching the AD8346 and AD8347 boards is about – 8 dBm as recommended by the manufacturer [30, 17].

For each T/R module, the IP, IN, QP and QN signals from the AD8346 modulator board are connected to the NI-9263 AO output terminals. The IOPP, IOPN, QOPP, QOPN signals from the AD8347 demodulator board are connected to the NI-9215 AI input terminals.

The host computer connects to the NI cRIO-9004 controller via a Ethernet connection. The power to the cRIO-9004 and cRIO-9104 FPGA is from a power supply adapter connected to the mains.

The required voltages of +5V, +12V, VGIN (+0.38V) come from standard COTS benchtop power supply units. Figure 24 shows the actual test bench built.

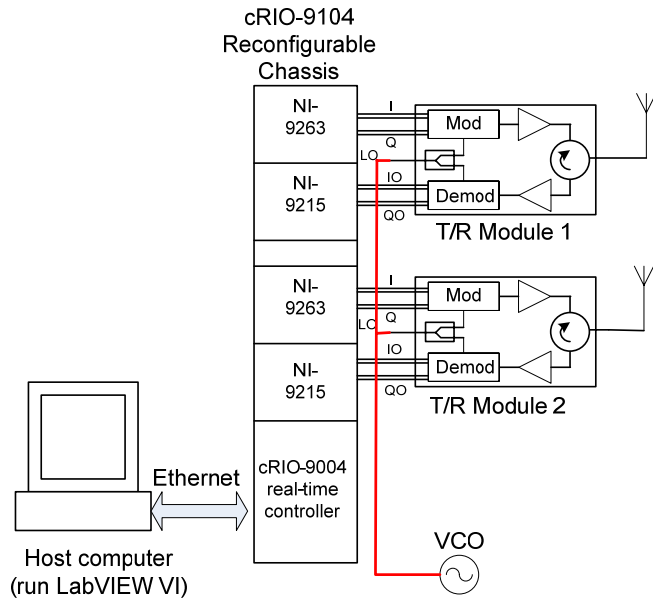

Figure 23. Block diagram of two-element array demonstrator test bench

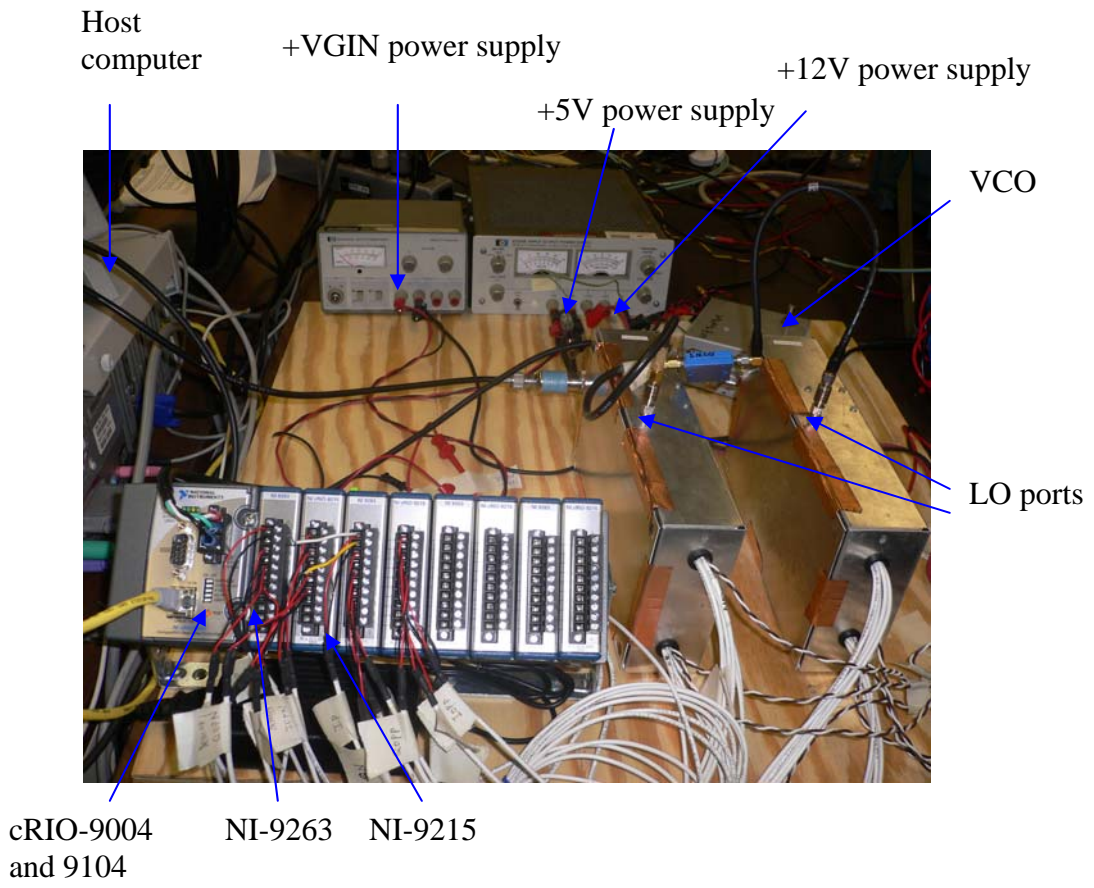

Figure 24. Two-element array demonstrator test bench

## E. LABVIEW PROGRAM

In using LabVIEW and the Compact RIO embedded system, there are three main steps to developing a working program:

- Define the various hardware to use with the FPGA module.
- Develop the FPGA application. This allows the FPGA to interact with the AO and AI modules. The format of the FPGA VI typically consists of a three-frame flat sequence structure which performs (a) timing and triggering, (b) control and module I/O and (c) synchronization with the host.
- Develop the host application. This allows the host to access the FPGA and perform such operations as downloading, reading or writing data, starting or stopping the VI.

### 1. LabVIEW Project Structure

The test software for the two-element array demonstrator is in the file *Two Element Demonstrator Array.lvproj*. The project structure is as shown in Figure 25.

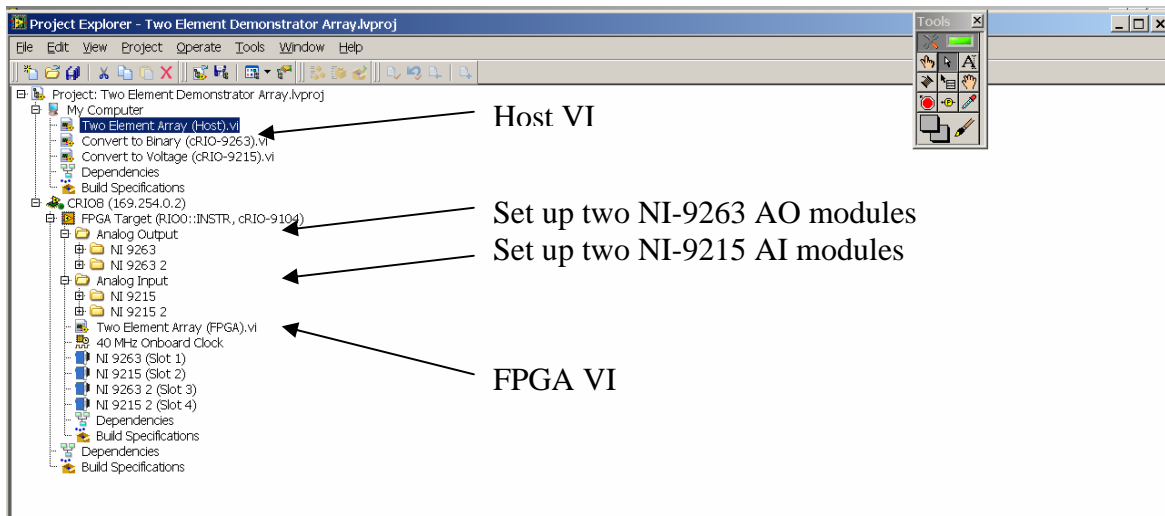

Figure 25. LabVIEW project structure

The host VI called *Two Element Array(Host).vi*, acts as the main program which performs the following tasks:

- runs a calibration routine for the NI-9263 and NI-9215 modules,
- reads in system control parameters such as amplitude and scan direction of the array, loop rate, duty cycle, frequency and passes them to the FPGA,
- sends the required  $I$  and  $Q$  data to the FPGA and out via the NI-9263 AO module to control the modulator phase shift,

- extracts the baseband  $I$  and  $Q$  data received from FPGA via the NI-9215 AI module and performs signal processing e.g. averaging, calculation of the amplitude and scan direction, etc.

*Convert to Binary.vi*, which was from NI software library, converts the output voltage values into binary code representation as the latter is required when performing analog operations with cRIO modules.

*Convert to Voltage.vi* does the reverse, converting binary code representation back into the analog voltage output values.

The VI downloaded to the FPGA target called *Two Element Array (FPGA).vi* enables the host to read the required data from the desired AI terminal or write data to the desired AO terminal.

## 2. User Interface

Figure 26 shows the user interface. Some of the key settings are highlighted.

There is a main controls palette. This allows the user to vary the duty cycle, PRF and the number of points per waveform cycle. The loop rate, which controls how fast the data is being read or written to the FPGA, can also be adjusted.

There is a palette whereby individual T/R modules can be controlled. If only testing of the transmission is needed, then only the transmit switches for the T/R modules need to be turned on. If only testing of the reception is needed, then only the receive switches for the T/R modules need to be turned on. If both the transmit and receive switches are turned on, the T/R modules will only operate in pulsed mode, i.e. when transmitting, the receive chain is “shut down” and vice versa. If the duty cycle is turned to 100%, then the waveform is CW.

For each T/R module, the user can adjust the amplitude and phase by adjusting the *Magnitude* and *Phase* dials. The corresponding  $I$  and  $Q$  data, based on Equations (6) and (32) are displayed as IP, IN, QP and QN.

The three charts, from top to bottom, show the real-time analog  $I$  and  $Q$  data read from the NI-9215 AI module, the 100-point averaged amplitude  $A(t)$  and 100-point averaged phase  $\theta(t)$  of the received signal respectively. The signal is recovered by

$$A(t) = \sqrt{I^2(t) + Q^2(t)} \quad (33a)$$

and

$$\theta(t) = \tan^{-1}\left(\frac{Q(t)}{I(t)}\right). \quad (33b)$$

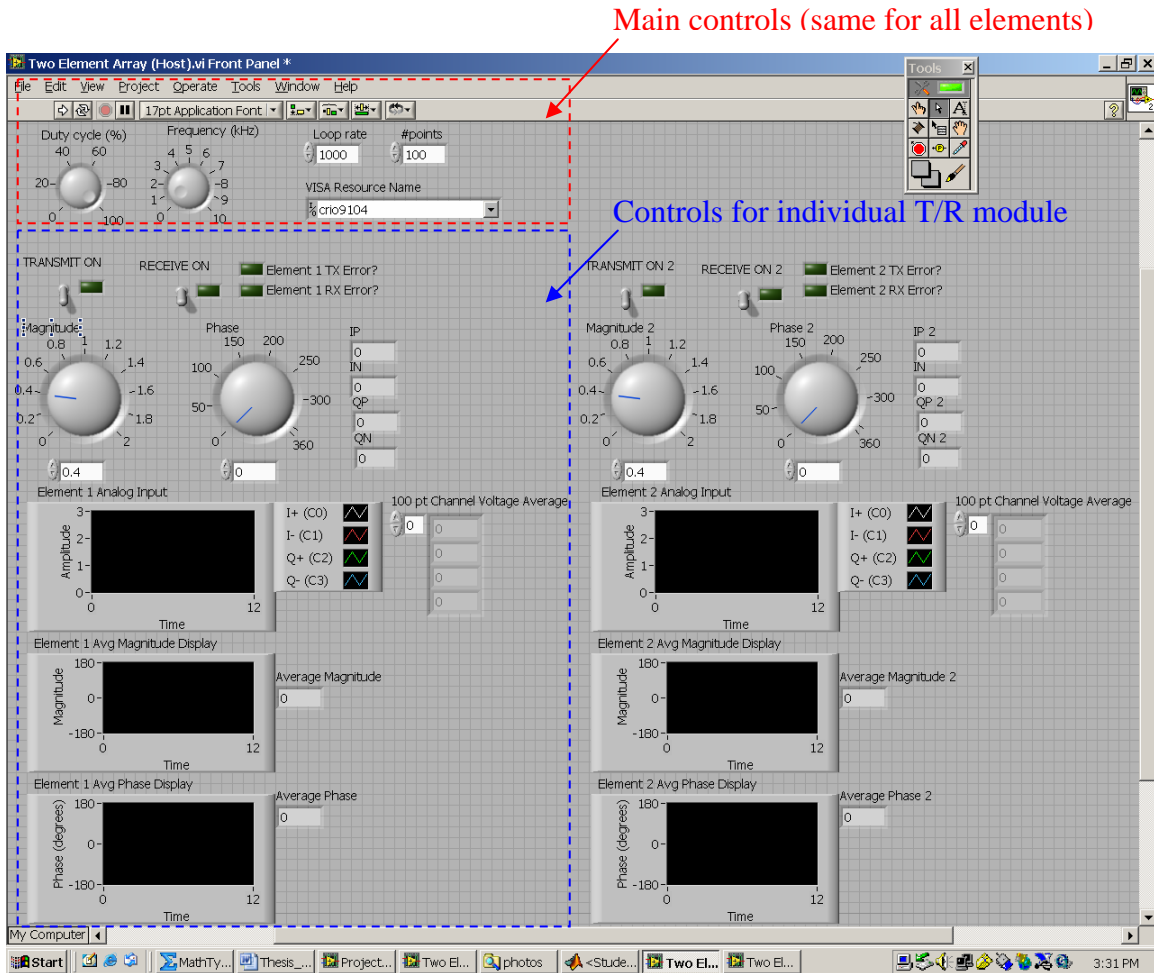

Figure 26. Demonstrator user interface

As a summary, this chapter has described the hardware of the T/R module, as well as the NI devices and software used to build the two-element array demonstrator test bench. The next chapter describes the measurements conducted to evaluate the T/R module's performance.

THIS PAGE INTENTIONALLY LEFT BLANK

## V. MEASUREMENTS AND RESULTS

### A. DC POWER CONSUMPTION

The DC power consumption of the T/R module was measured and is tabulated in Table 7.

S/N	Designation	Component	Voltage (V)	Current (mA)	Power (W)
1	C1	AD8346	+5.0	30	0.15
2	C2	AD8347	+5.0 +0.38	61 0.6 $\mu$ A	0.30 Negligible
3	AMP1	LPA 4-14	+12.0	85	1.02
4	AMP2	LNA-2700	+12.0	55	0.66
Total					2.13

Table 7. DC power consumption of T/R module

Note that the above measurement excludes the power consumption of the VCO. At +5V, the VCO draws about 58 mA, thus giving a power consumption of 0.29 W.

### B. INTERFERENCE BETWEEN THE MODULATOR AND DEMODULATOR BOARDS

These tests were performed to check if the proximity of the modulator and demodulator boards would cause interference in the signals measured.

#### 1. Transmit Output when Demodulator is On/Off

From the test setup shown in Figure 27, it can be seen that only T/R module 1 was activated. A CW signal was injected into the receive end at the LNA input while the circulator port to the LNA was terminated with a 50 ohm load. The RF transmit port was connected to a negative polarity HP423B detector and fed to Channel 1 of the oscilloscope. With the CW signal turned off and on, the transmitted output waveform was observed.

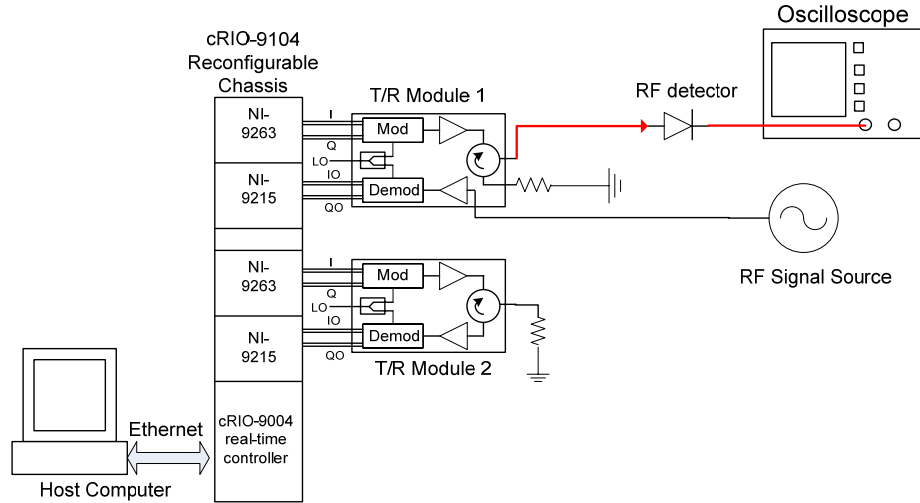

Figure 27. Setup for measuring demodulator's effect on transmitter output

Figure 28 shows the transmit output when the demodulator was off and Figure 29 shows it when the demodulator was on.

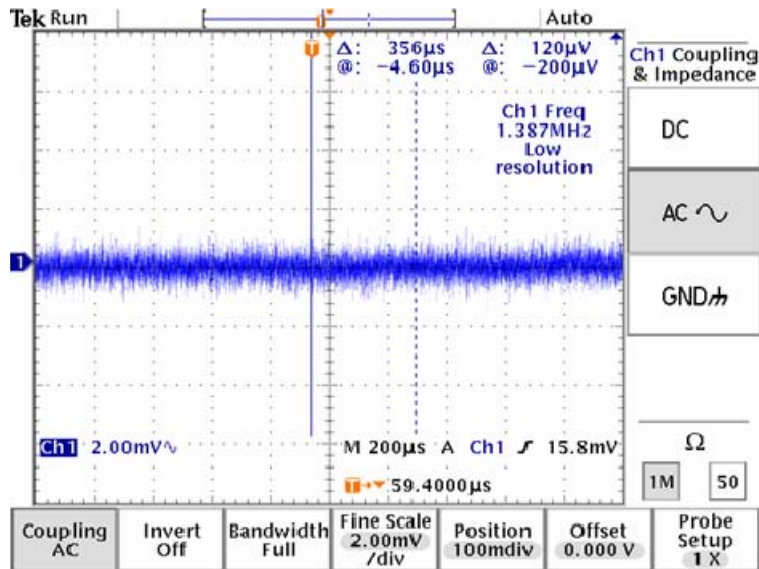

Figure 28. Transmit output when demodulator was off

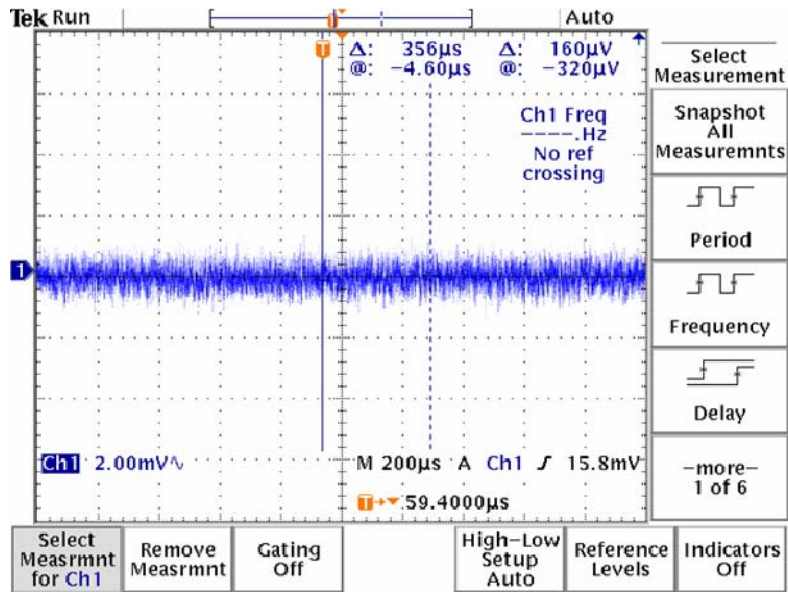

Figure 29. Transmit output when demodulator was on

There was no noticeable change in the transmit output when the receive end was on or off.

## 2. Receive Output When Modulator is On/Off

From the test setup shown in Figure 30, a CW signal was injected into the receive end at the LNA input while the transmit port and circulator receive output were terminated with 50 ohm loads. The transmitter was turned on and off and the receive output was observed in the *Element Analog Input Chart* in the User Interface. Figures 31 and 32 show the receive output when the transmitter was off and on respectively.

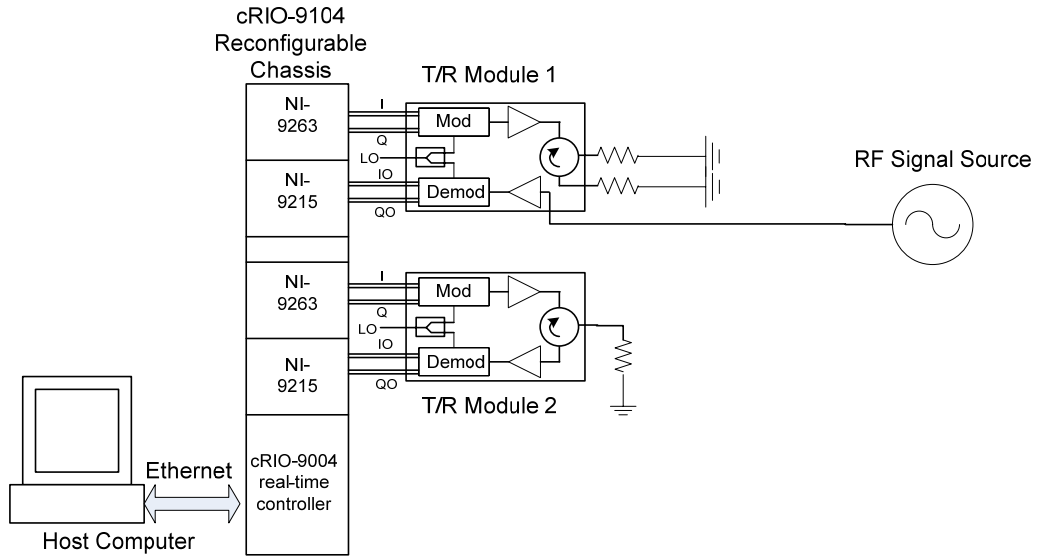

Figure 30. Setup for measuring modulator's effect on received output

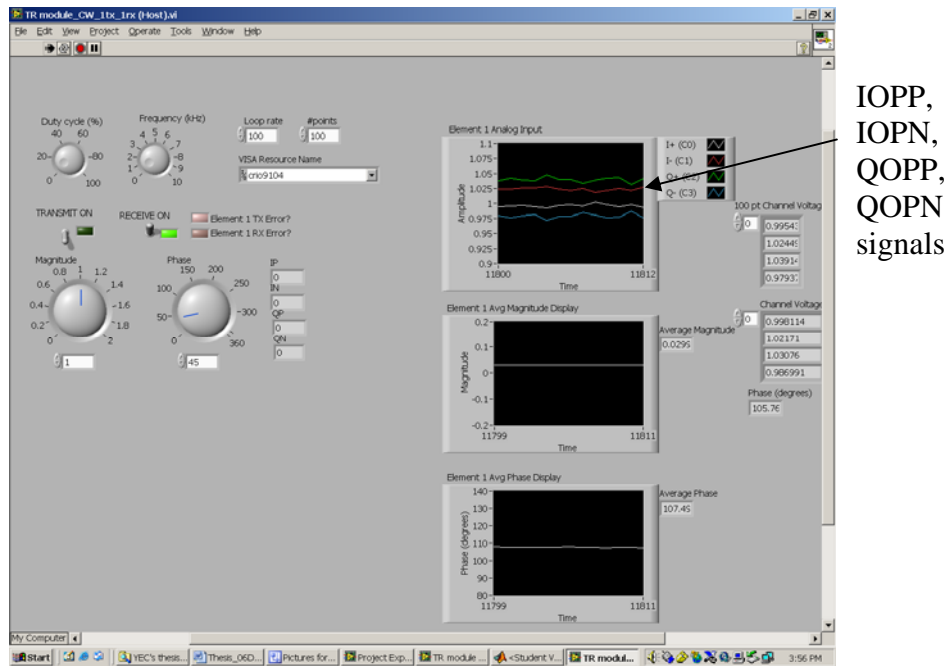

Figure 31. Receive output when modulator was off

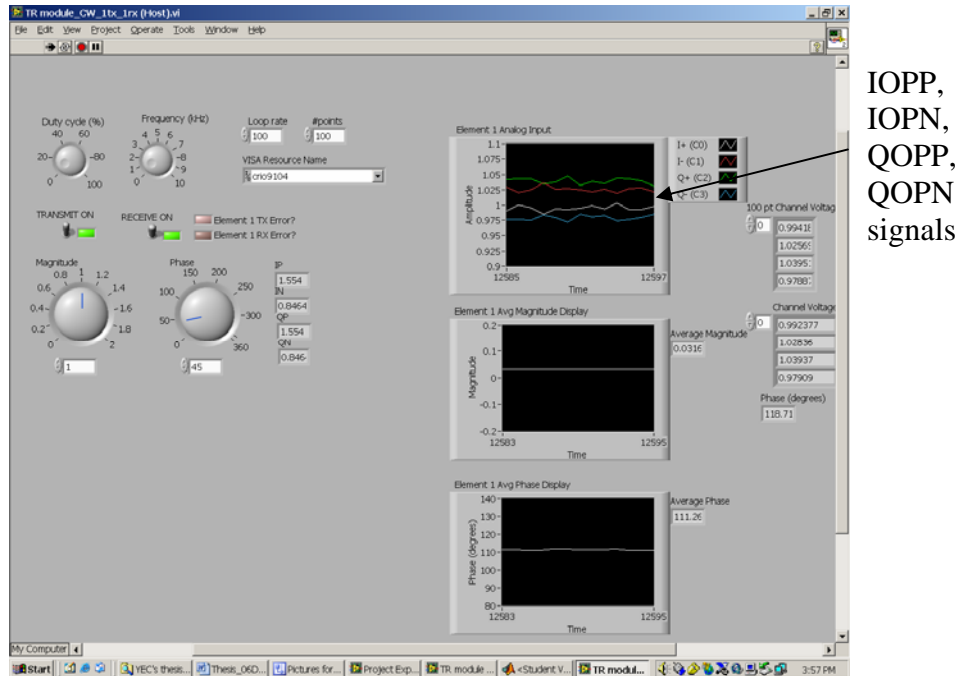

Figure 32. Receive output when modulator was on

It can be seen that there were no noticeable changes to the IOPP, IOPN, QOPP, QOPN signals whether the modulator was on or off. The signals remained in the 0.95 to 1.05 V range as before. From the two series of measurements, it can be concluded that the interference between the modulator and demodulator boards is not significant enough to affect the performance of the eight-element array to be built later.

### C. TRANSMIT AND RECEIVE DELAYS

Measurements were taken to give an indication of the delays in the transmit and receive paths inside the T/R module. The delay is a measure of the response time of the electronics in the modulator and demodulator as well as propagation delay. The electronics include mixers, filters and baseband amplifiers. The delay is important as it affects the time response of the radar and determines the threshold setting for the time of arrival. The devices used to measure the RF output thus need to have short delay and any residual delay must be compensated for in the range calculation. The HP423B negative polarity RF detector used in this measurement has a 8 to 12 ns rise time [31].

#### 1. Transmit Delay

In the setup shown in Figure 33, one of the NI-9623 analog outputs AO0 was connected to Channel 1 of the oscilloscope and set as the trigger source, and the RF

transmit output of T/R Module 1 was connected to a HP 423B RF detector and then to Channel 2 of the oscilloscope. This measurement was done in the pulsed mode so that the ON and OFF edges of the signals could be measured. Figures 34 and 35 show the rise and fall response times. The delay was measured from the baseband 50% to the RF 10% or 90% level.

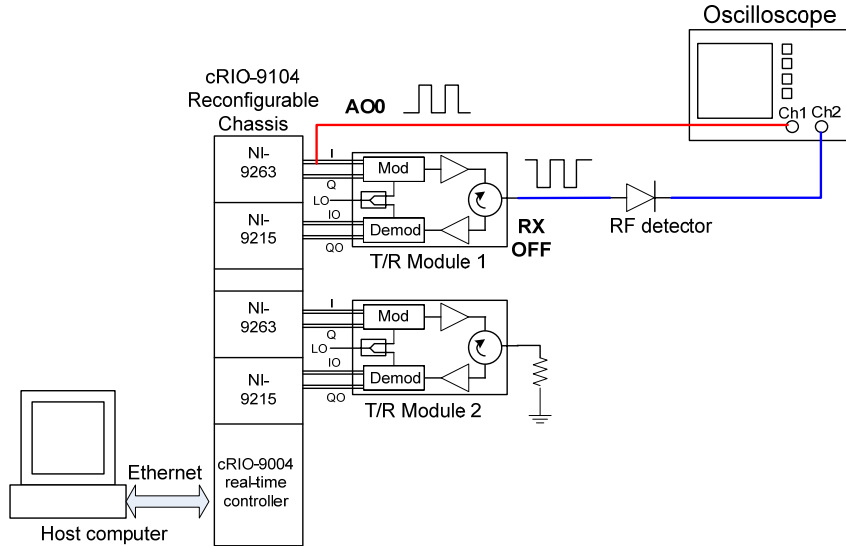

Figure 33. Setup for measuring transmit delay

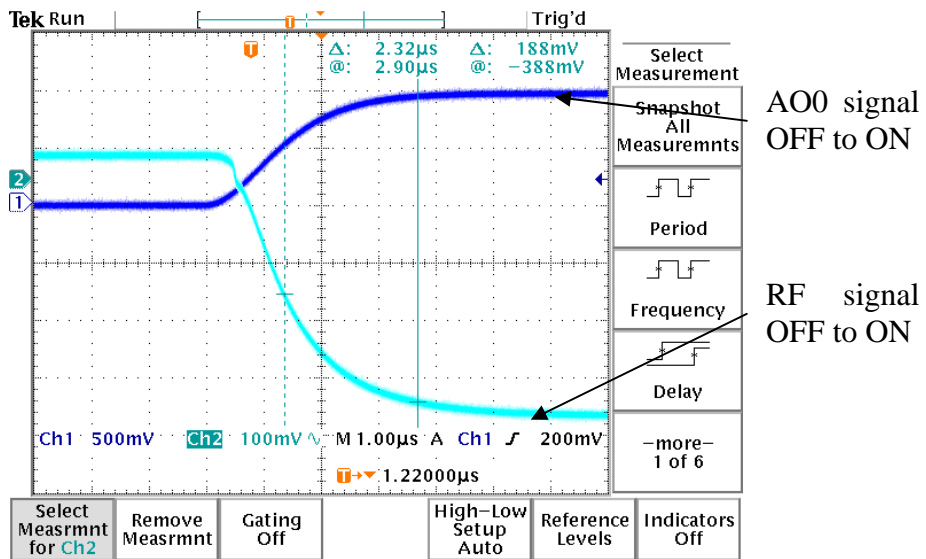

Figure 34. Transmit delay (rising edge)

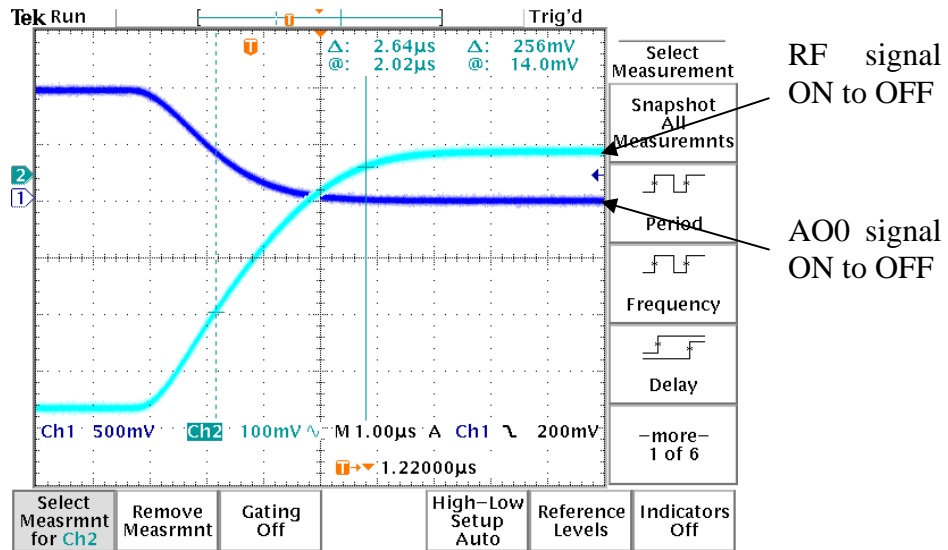

Figure 35. Transmit delay (falling edge)

The average delay measured was about 2.5  $\mu$ s. This implies that the radar would have to schedule at least 5  $\mu$ s in each Pulse Repetition Interval (PRI) to allow for this delay. It is noted that the above measurement was not the measurement of the delay in the T/R module, as the response time of the signal envelopes may be limited by that of the DAC in the NI-9263 Analog Output module. A simple experiment was performed with a high-speed function generator providing the pulsed AO0 signal instead of the DAC. Figures 36 and 37 show the results.

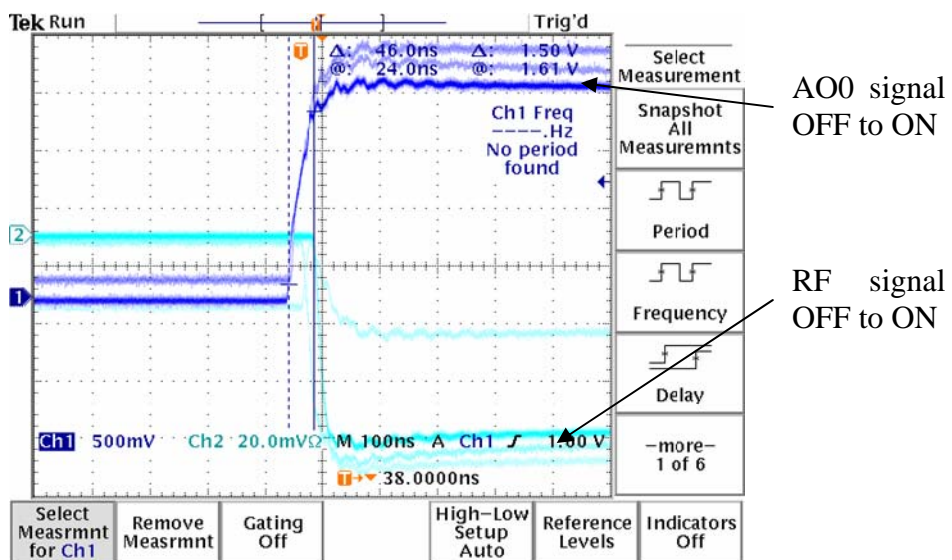

Figure 36. Transmit delay (rising edge) with function generator

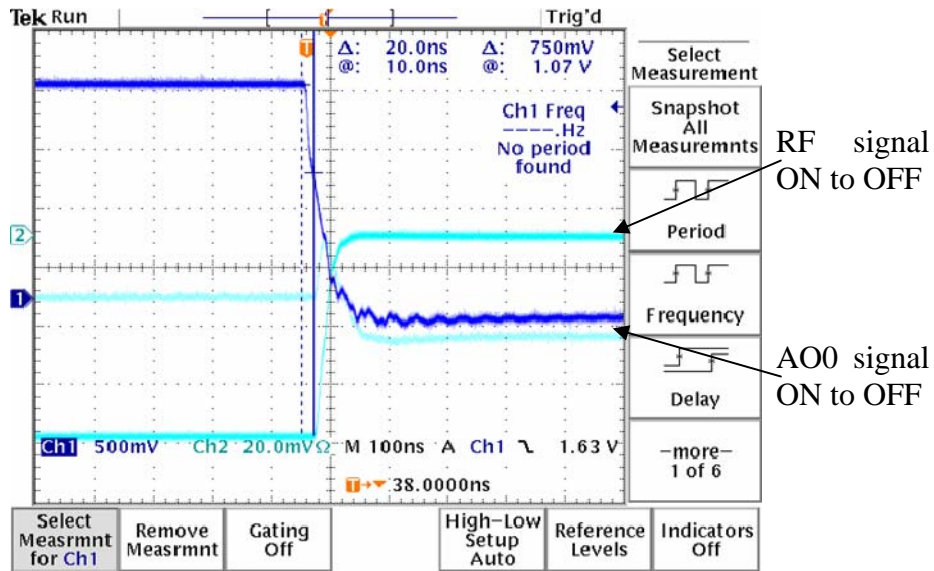

Figure 37. Transmit delay (falling edge) with function generator

It can be seen that there is a 46 ns delay between the start of AO0 signal transition and the start of the RF signal transition from off to on, and a 20 ns delay between the two signals from on to off. These are likely the actual propagation delays in the electronics (modulator, PA and circulator) in the T/R module, discounting the delays in the short interconnecting RF cable assemblies. The modulator and PA are solid-state devices working from 800 to 2500 MHz and DC to 4000 MHz respectively. This implies that their rise and fall times should be on the order of sub-nanoseconds and so the delays measured in Figures 36 and 37 could be attributed to the circulator itself.

As the eight-element array prototype is likely to be working with a Pulse Repetition Interval (PRI) on the order of milliseconds and the pulse width a fraction of that, i.e. hundreds of microseconds, the delays measured in this section and those which follow are not very critical and hence are measured using the DAC or ADC in the NI-9263 or 9215 module respectively. Further investigation may be done to ascertain if the response times of the DAC or ADC can be improved.

## 2. Receive Delay

In the setup shown in Figure 38, the pulsed RF transmit output from T/R Module 2 was divided by a 1:2 power splitter into two equal signals, one of which was connected to the RF detector and to Channel 1 of the oscilloscope and set as the trigger source,

while the other was injected into the RF port of T/R Module 1. The NI-9215 analog input AIO line was tapped to Channel 2 of the oscilloscope. Figure 39 shows the receive delay for the rise edge.

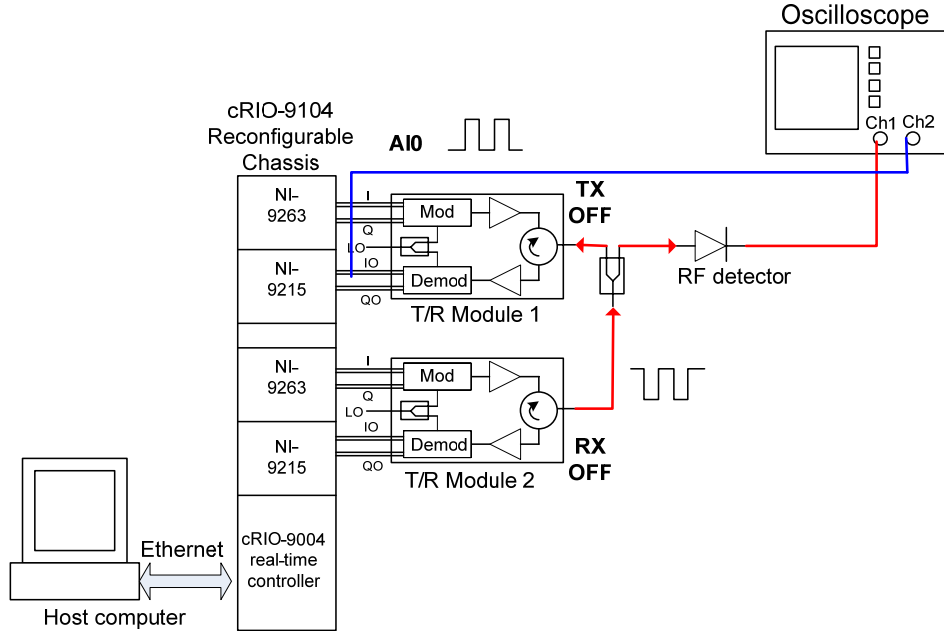

Figure 38. Setup for measuring receive delay

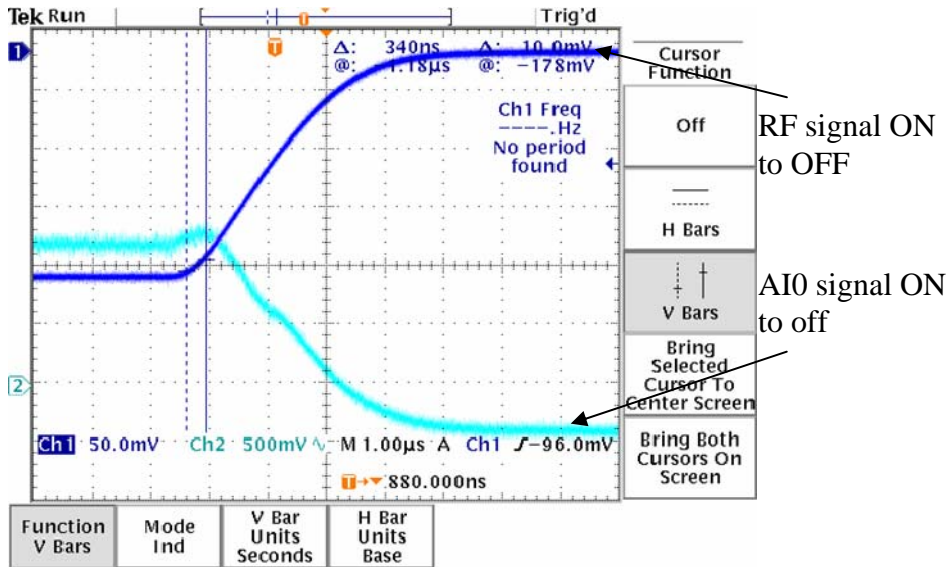

Figure 39. Receive delay (rising edge)

The average receive delay was about 2  $\mu$ s. Again, it is noted that the measurement above reflected the response time of the DAC, which affected the rise time of the RF, pulsed signal from T/R module 2.

#### D. SIMULTANEOUS TRANSMISSION AND RECEPTION

Measurements were done to ascertain if the LabVIEW code has been correctly implemented in the FPGA and to demonstrate that two T/R modules can transmit and receive simultaneously.

##### 1. Simultaneous Transmission

In the setup shown in Figure 40, the RF transmit outputs of two T/R modules were connected to HP 423B RF detectors and then to Channels 1 and 2 of the oscilloscope respectively. Figures 41 and 42 show the time difference between the transmitted signals from the two T/R modules. The average time difference, from 10% to 90% level of the signals, was about 3  $\mu$ s.

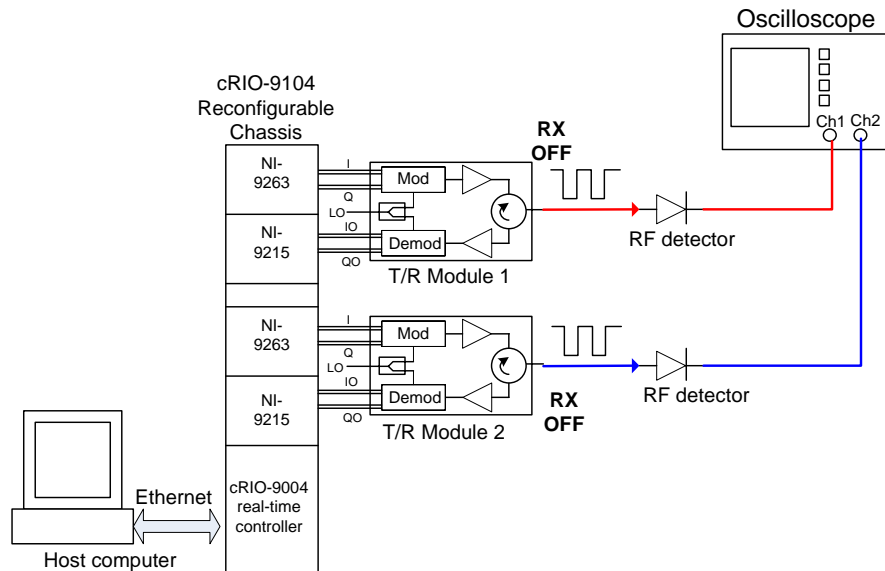

Figure 40. Setup for testing synchronous transmission

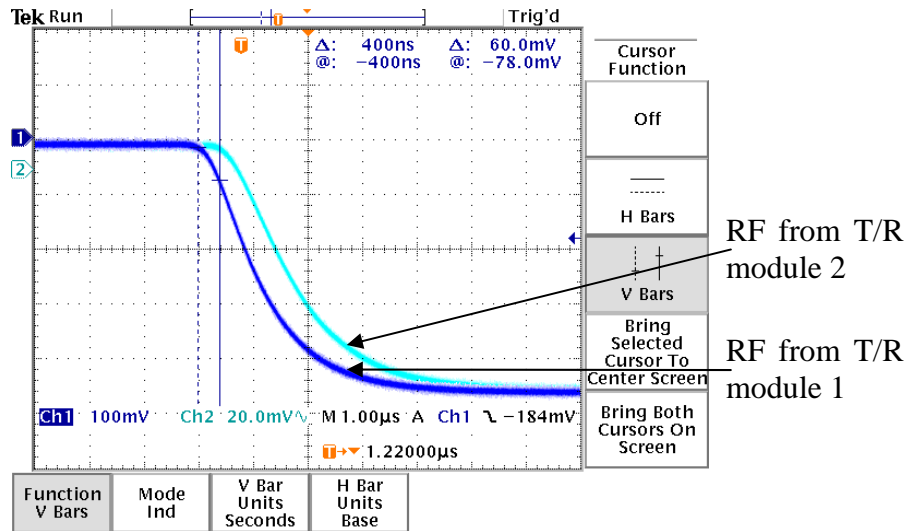

Figure 41. Simultaneous transmit off to on

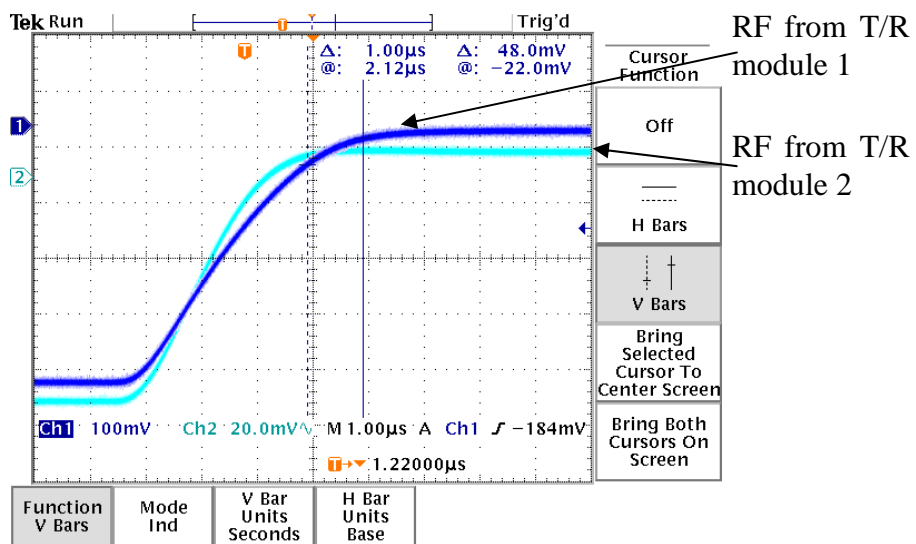

Figure 42. Simultaneous transmit on to off

## 2. Simultaneous Reception

In the setup shown in Figure 43, a pulsed RF signal was divided and injected into each of the RF port of T/R modules 1 and 2. The AI0 lines on T/R module 1 and 2 were tapped and connected to Channels 1 and 2 of the oscilloscope respectively. Figure 44 shows the time difference between the received baseband data from the two T/R modules.

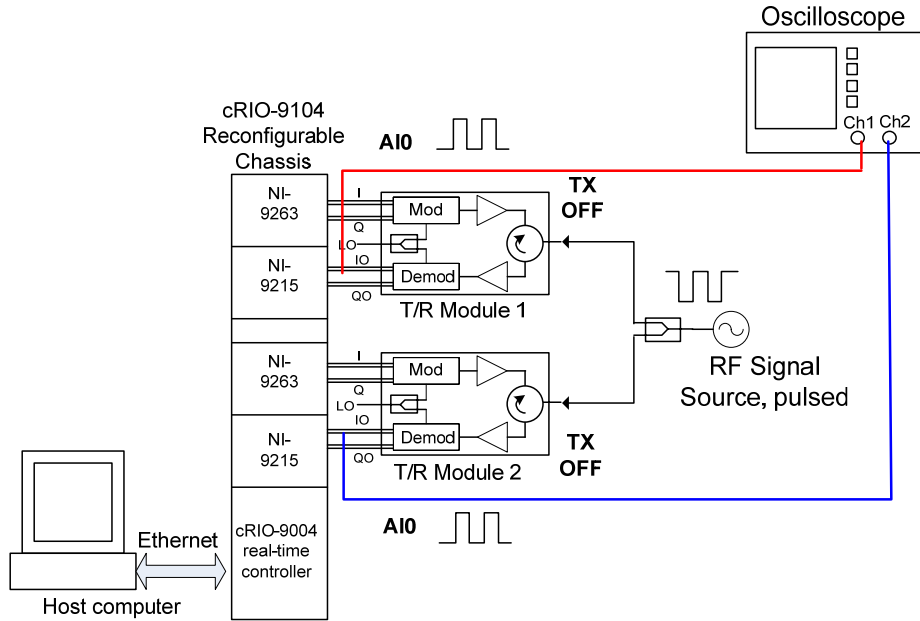

Figure 43. Setup for testing synchronous reception

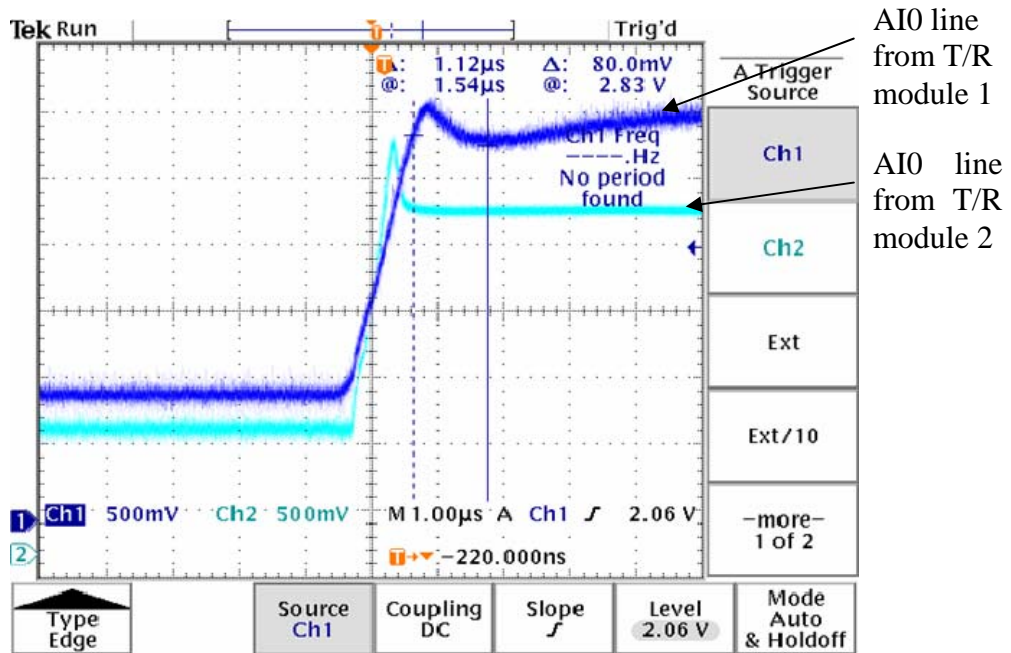

Figure 44. Simultaneous receive on to off

The time difference was about 1  $\mu\text{s}$ . Hence, the average time difference for transmit and receive was 2  $\mu\text{s}$ . This should not significantly affect the performance of the eight-element array. Again, it is noted that the measurements above included the response time of the DAC or ADC.

### E. PHASE ERROR MEASUREMENT

In the setup shown in Figure 45, a CW RF signal was transmitted from T/R module 1 to T/R module 2. The  $I$ - $Q$  differential amplitude on T/R module 1 was set to 2 V and the transmitted phase  $\theta_t$  varied from 0 to 360 degrees. The RF signal was passed through a RF attenuator of about 60 dB to bring the input RF power to a level of about  $-50$  dBm so that it is within the linear operating range of the receive channel. The received differential pairs of  $I(t)$  and  $Q(t)$  voltages, and phase  $\theta_r$  were recorded and tabulated in Table 8. A plot of  $\theta_r$  vs.  $\theta_t$  is shown in Figure 46, with a least squares line fit done.

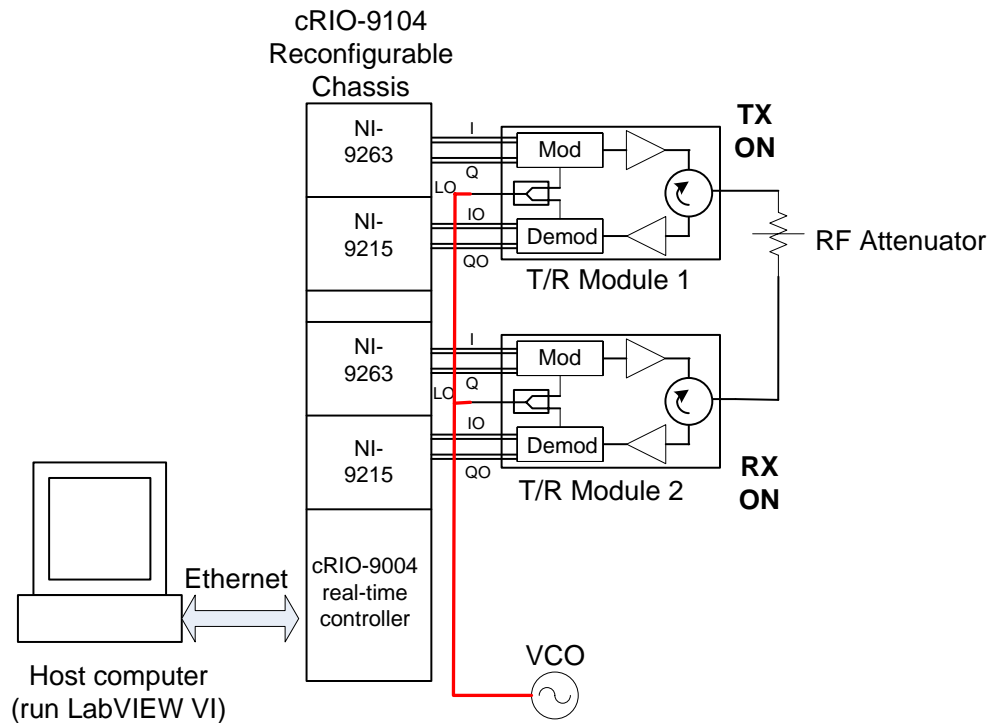

Figure 45. Setup for phase error measurement

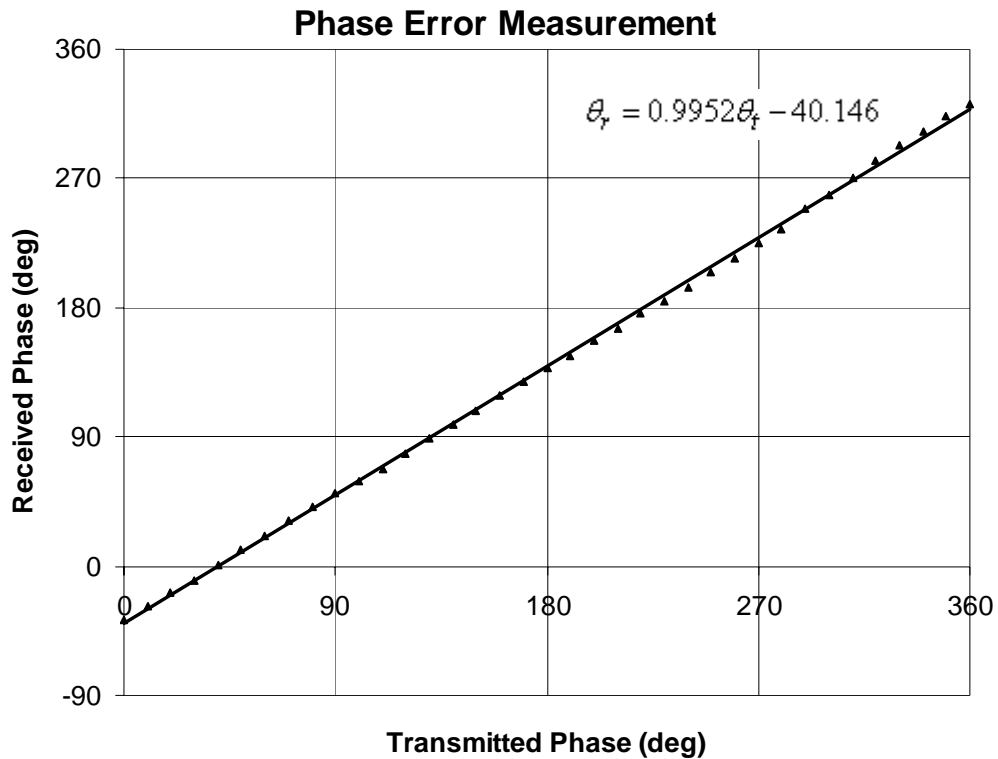

Figure 46. Plot of received phase vs. transmitted phase

From Figure 46, the line fit equation is  $\theta_r = 0.9952\theta_t - 40.146$ . Thus, accounting for an offset of -40 degrees, there is actually very little error between the received and transmitted phases. The maximum phase error is probably about  $(1 - 0.9952) \times 360 = 1.7$  degrees. The offset is likely due to the constant phase shift of the attenuator and RF cable connected between T/R modules 1 and 2 and can be removed during calibration of the array. This further shows the transmit and receive paths of the T/R module are functioning as required.

$\theta_t$ (deg)	I+ (V)	I- (V)	Q+(V)	Q- (V)	$A_r$ (V)	$\theta_r$ (deg)
0	1.021	1.001	1.010	1.010	0.052	-38.0
10	1.023	1.001	1.016	1.007	0.046	-28.2
20	1.025	1.000	1.020	1.004	0.046	-18.6
30	0.167	0.997	1.023	1.000	0.048	-10.0
40	1.027	0.998	1.028	0.996	0.050	0.2
50	1.028	0.996	1.032	0.991	0.052	11.4
60	1.026	0.998	1.037	0.987	0.052	21.2
70	1.024	1.000	1.041	0.982	0.053	32.0
80	1.023	1.002	1.045	0.978	0.053	41.8
90	1.020	1.006	1.048	0.976	0.055	50.4
100	1.016	1.009	1.050	0.975	0.049	59.5
110	1.012	1.012	1.052	0.972	0.052	68.0
120	1.007	1.018	1.051	0.972	0.049	78.6
130	1.004	1.021	1.054	0.970	0.050	89.1
140	0.999	1.027	1.053	0.970	0.052	98.9
150	0.994	1.031	1.054	0.971	0.050	108.0
160	0.990	1.035	1.050	0.974	0.052	118.4
170	0.987	1.038	1.047	0.977	0.049	127.9
180	0.984	1.042	1.046	0.978	0.053	137.8
190	0.982	1.044	1.041	0.981	0.053	146.1
200	0.979	1.046	1.037	0.986	0.050	156.5
210	0.978	1.047	1.030	0.989	0.051	165.3
220	0.977	1.048	1.029	0.994	0.050	175.7
230	0.977	1.049	1.025	0.998	0.050	185.1
240	0.978	1.046	1.020	1.002	0.051	194.6
250	0.982	1.044	1.017	1.006	0.050	205.1
260	0.982	1.043	1.013	1.010	0.048	214.5
270	0.985	1.039	1.011	1.013	0.048	225.6
280	0.988	1.037	1.008	1.015	0.047	234.4
290	0.994	1.030	1.007	1.016	0.005	249.0
300	0.998	1.027	1.005	1.018	0.046	258.0
310	1.003	1.022	1.004	1.020	0.046	270.5
320	1.007	1.018	1.005	1.018	0.047	282.4
330	1.011	1.013	1.005	1.018	0.048	292.9
340	1.016	1.009	1.007	1.016	0.048	303.2
350	1.019	1.006	1.009	1.013	0.047	313.5
360	1.020	1.003	1.012	1.011	0.049	321.8

Table 8. Measured received I and Q voltages and phase (with differential input amplitude of 2 V)

#### F. $S_{11}$ OF T/R MODULE RF PORT

Burgstaller [2] measured the  $S_{11}$  of the dipole antenna element to be used in the demonstrator array. As seen from Chapter II, the antenna reflection coefficient is important in (1) determining the leakage between the transmit and receive channels, as well as (2) affecting the array RCS. The  $S_{11}$  of the RF port of the T/R module was

measured using a Vector Network Analyzer (VNA). Figure 47 shows that at 2.4 GHz, a return loss of -16.5 dB was obtained, which corresponds to a VSWR of 1.4.

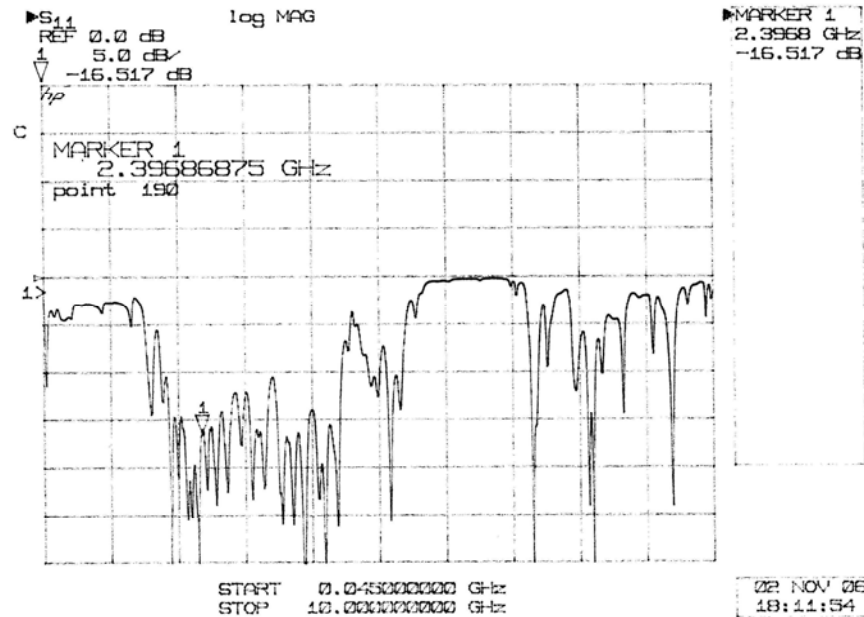

Figure 47.  $S_{11}$  of RF port of T/R module

As a summary, various power and timing measurements were done on the T/R module. They showed that despite the close proximity of the modulator and demodulator boards in the compact T/R module chassis, there was no significant interference between them. Also, given the NI hardware configuration, the various propagation delays of the transmit and receive paths were acceptable as the PRI of the eight-element array is likely to be in the order of milliseconds and the pulse width a fraction of that, i.e., hundreds of microseconds. The test bench software functioned properly with two T/R modules simultaneously transmitting and receiving on the order of two microseconds on average. In addition, the propagation delays in both the transmit and receive channels of the T/R module are very small that they should not affect the performance of the eight-element array.

## VI. CONCLUSIONS AND RECOMMENDATIONS

### A. CONCLUSIONS

An analysis of the performance of the T/R module and the requirements for an eight-element distributed array radar were done, the results of which are summarized in Tables 9 and 10, respectively.

Parameter	Performance
Bandwidth	50 MHz
Noise output power	-96.9 dBm
Noise figure	3.06 dB
Noise temperature	297 K
Max. RF input power	-44.7 dBm giving SNR of 52.2 dB
Sensitivity	-87.7 dBm giving SNR of 9.2 dB
Dynamic range	43 dB
Max. RF output power	+10.7 dBm

Table 9. Summary for the T/R module

Parameter	Performance/ Requirements
Bandwidth	50 MHz (may be limited to 20 MHz if using Wi-Fi devices)
Noise output power	-93.7 dBm
Noise temperature	597 K
Detection range	62.6 m
PRF and Duty cycle	Keep $\frac{DU}{f_p}$ or $\tau$ above $3 \times 10^{-5}$ s to maintain at least 3 samples per pulse
Data rate	102.4 Mbps
Computational power of DBF	400 million COPS

Table 10. Summary for an eight-element array

A number of characterization measurements were done on the T/R module. These measurements showed the following:

- There was no observable interference between the modulator and demodulator boards inside of the T/R module chassis.
- The total delays in the transmit and receive paths, including the response time of the electronics and NI hardware, in the T/R module were on the

order of five microseconds. The actual delay is likely to be much shorter and will not be a problem with the eight-element array demonstrator which is expected to be working with a PRI of milliseconds and pulse width of hundreds of microseconds.

- Given the existing hardware, two T/R modules could transmit or receive simultaneously within two microseconds on average. Again, the difference could be smaller and is not expected to be a problem for the eight-element array demonstrator.
- There was good agreement between the received and transmitted phases between two T/R modules, less an offset of 40 degrees which can be attributed to the RF attenuators and cables connected between the two T/R modules. The offsets will be removed during the antenna calibration.

In conclusion, two T/R modules were successfully built and a two-element demonstrator test bench was completed. A test software, written with LabVIEW, has enabled each T/R module to transmit or receive in CW or pulsed mode. The sampling loss is related to the number of samples per pulse which is in turn determined by the sampling rate of the ADC or DAC, duty cycle and PRF of the radar waveform. Given a 100 kS/s sampling rate, it was concluded that the ratio of duty cycle to PRF should be kept above  $3 \times 10^{-5}$  s so as to have at least three samples per pulse.

## **B. RECOMMENDATIONS FOR FUTURE WORK**

To continue the work to build the prototype eight-element array radar, the following areas need to be studied or worked on:

### **1. Expand the Array Demonstrator Test Bench**

For the hardware, six more T/R modules need to be assembled and tested. For the test and control software, six similar transmit and receive subroutines need to be added to the host VI (*Two Element Array (Host).vi*) and the FPGA VI (*Two Element Array (FPGA).vi*).

### **2. Time and Phase Synchronization Method**

The key to operating a distributed array radar is achieving two-way coherent operation by means of time and phase synchronization between the array elements. The methods proposed and experimentally proved by Attia [32] should be further studied to assess the additional hardware and software solutions needed to bring time synchronization and phase cohering for the eight-element array.

The eight-element array will require the use of two NI cRIO-9104 chassis. The chassis will need to be synchronized. The following methods described in [33] may be considered:

- Use a **common hardware trigger** which synchronizes events between the systems. This is implementable with digital I/O modules in each system. The master system sends a digital pulse to one of its digital outputs. Each of the slave systems will look for this pulse on one of their digital inputs and start their process,
- Use a **shared clock** signal between multiple cRIO systems and use the external clock to run specific processes on each cRIO chassis that needs to be synchronized. In this way, processes will be done at the same rate fully synchronized on multiple systems, or
- Implement a **fully synchronized hardware solution**. This needs a digital I/O module in each chassis. The master device generates a digital signal and reads it to each of the slaves.

### 3. Transmit Leakage Reduction or Cancellation Method

Because of the short range due to the low power operation, there will be overlap in the transmit and receive pulses unless an ultra-short pulse is used. Direct leakage from the transmitter must be cancelled in order to detect targets with low SNR. Also, using the CW mode results in the presence of the transmitter leakage, described in Chapter II, which the present hardware cannot cancel.

If future testing is to be done with CW signals when all the elements are transmitting or receiving simultaneously, then the following leakage reduction or cancellation methods may be studied:

- **Reducing leakage by increasing the isolation** – a pair of PIN diode switches may need to be included in the transmit and receive chain. One switch is likely to be after the power amplifier before the circulator and the other switch after the circulator before the low noise amplifier. Thus, when transmitting, the PIN diode switch in the transmit chain is on and the switch in receive chain off, thus better isolating the receive chain during transmission. When receiving, the reverse happens with the PIN diode switch in the transmit chain off and the switch in receive chain on. A PIN diode switch can provide 40 to 50 dB isolation and can handle relatively large powers. Its switching speed is in the order of nanoseconds and thus should not affect the radar operation significantly.
- **Reducing leakage by having separate antennas** – Another solution may be to have separate transmit and receive antennas on the T/R module, if there is no space constraint. The transmit path would be effectively

isolated from the receive path inside the T/R module. Diversity techniques in frequency or space could be used to address the issue of mutual coupling between the closely spaced antennas. This would allow for simultaneous transmission and reception which may bring about an added advantage in the shipborne BMD application. Another version of this is to restrict the distance between elements that are transmitting and those that are receiving.

- **Cancelling leakage** – There has been considerable research into leakage cancellation methods, mostly for Frequency Modulated Continuous Wave (FMCW) radars. Beasley [33] proposed an analog method in the form of a vector modulator to cancel the leakage while [34] proposed a digital method to do the cancellation in the DSP. However, effective cancellation means tuning the feedback signal to have the same amplitude but exactly 180 degrees out of phase compared to the transmit signal. This may not be practical in the implementation of a wirelessly networked distributed array radar, where there is a need to do the correction for hundreds, if not thousands, of elements.

## LIST OF REFERENCES

- [1] US Navy- Future Surface Combatant Program, <http://www.peoships.crane.navy.mil>, last visited October 2006.
- [2] Burgstaller, G., “Wirelessly networked opportunistic digital phased array: design and analysis of a 2.4 GHz demonstrator,” Master’s Thesis, Naval Postgraduate School, Monterey, California, September 2006.
- [3] Esswein, L. C., “Genetic algorithm design and testing of a random 3-D 2.4 GHz phased array transmit antenna constructed of commercial RF microchips,” Master’s Thesis, Naval Postgraduate School, Monterey, California, June 2003.
- [4] Eng, C. S., “Digital antenna architectures using commercial off the shelf hardware,” Master’s Thesis, Naval Postgraduate School, Monterey, California, December 2003.
- [5] Ong, C. S., “Digital phased array architectures for radar and communications based on off-the-shelf wireless technologies,” Master’s Thesis, Naval Postgraduate School, Monterey, California, December 2004.
- [6] Ong, W., “Commercial off the shelf direct digital synthesizers for digital array radar,” Master’s Thesis, Naval Postgraduate School, Monterey, California, December 2005.
- [7] Tong, C. H., “System study and design of broad-band U-slot microstrip patch antennas for aperstructures and opportunistic arrays,” Master’s Thesis, Naval Postgraduate School, Monterey, California, December 2005.
- [8] Yong, Y. C., “Receive channel architecture and transmission system for digital array radar,” Master’s Thesis, Naval Postgraduate School, Monterey, California, December 2005.
- [9] Yong, L., “Sensor synchronization, geolocation and wireless communication in a shipboard opportunistic array,” Master’s Thesis, Naval Postgraduate School, Monterey, California, March 2006.
- [10] Jenn, D. C., Presentation notes, “Aperstructures, opportunistic arrays and BMD,” Naval Postgraduate School, Monterey, California.
- [11] *Aviation Week and Space Technology*, “Conformal arrays,” October 2006.
- [12] Stapleton, R., “The use of field programmable gate arrays in high performance radar signal processing applications,” *IEEE International Radar Conference*, pp 850-855, 2000.

- [13] Cantrell, B., "Development of a digital array radar (DAR)," *IEEE AESS Systems*, pp. 22-27, March 2002.
- [14] Yuanbin, W., Jinwen, L., "The design of digital radar receivers," *IEEE AES Systems*, pp. 35-42, January 1998.
- [15] Datasheet for AD9858 Rev A, Analog Devices.
- [16] Wardrop, B., "Digital beamforming and adaptive techniques," IEE Tutorial Meeting, Marconi Research Centre, 1998.
- [17] Datasheet for AD8347 EVAL demodulator evaluation board, Analog Devices.
- [18] Heimiller, R.C., Belyea, J.E., Tolinson, P.G., "Distributed array radar," *IEEE Transactions on Aerospace and Electronic Systems*, Vol. AES-19 No. 6, pp 831-839, November 1983.
- [19] Skolnik, M. I., *Introduction to Radar Systems*, 3<sup>rd</sup> edition, McGraw-Hill, New York, 2001.
- [20] Gray, N., Application Notes, "ABCs of ADCs," National Semiconductor, 2003.
- [21] Fourikis, N. *Advanced Array systems, application and RF technologies*, pp 336-339, Academic Press, 2000.
- [22] Datasheet for power divider, part number 40266, Anaren.
- [23] Datasheet for SMA-M straight & right angle connectors part numbers 901-9501-3 and 901-9251-3, Amphenol.
- [24] Datasheet for CompactRIO reconfigurable chassis cRIO-9104, National Instruments.
- [25] Datasheet for CompactRIO real-time embedded controller, cRIO-9004, National Instruments.
- [26] Tutorial notes "Arbitrary waveform generation with RIO-enabled hardware and the LabVIEW FPGA module," <http://zone.ni.com/devzone/cda/tut/p/id/3027>, National Instruments, last accessed October 4, 2006.
- [27] Datasheet for C series analog output modules, NI-9263, National Instruments.
- [28] Datasheet for C series analog input modules, NI-9215, National Instruments.
- [29] Datasheet for VME08100 Voltage Controlled Oscillator, Z-Communication Inc.
- [30] Datasheet for AD8346 EVAL modulator evaluation board, Analog Devices.
- [31] Datasheet for RF detector, part number HP423, Agilent Technologies.

- [32] Attia, E. H., Abend, K., "An experimental demonstration of a distributed array radar," *IEEE Proceedings*, 1991.
- [33] Tutorial notes, "Synchronizing multiple CompactRIO chassis," <http://zone.ni.com/devzone/cda/tut/p/id/4217>, National Instruments, last accessed September 29 2006.
- [34] Beasley, P. D. L., Stove, A. G., Reits, B. J., "Solving the problems of a single antenna frequency modulated CW radar," *IEEE International Radar Conference* 1990. Vo.1 Iss. pp. 391-395, 7-10. May 1990.
- [35] Kaihui, L., Yuanxun, E. W., "Real-time DSP for reflected power cancellation in FMCW radars," *IEEE Proceedings*, 2004.

THIS PAGE INTENTIONALLY LEFT BLANK

## INITIAL DISTRIBUTION LIST

1. Defense Technical Information Center  
Ft. Belvoir, Virginia
2. Dudley Knox Library  
Naval Postgraduate School  
Monterey, California
3. Chairman, Code EC  
Naval Postgraduate School  
Monterey, California
4. Chairman, Code PH  
Naval Postgraduate School  
Monterey, California
5. Dr. Steven J. Russell  
Office of Naval Research  
Code 331  
Arlington, Virginia
6. Prof. Yeo Tat Soon  
Director, Temasek Defence Systems Institute  
National University of Singapore  
Singapore
7. Prof. David Jenn  
Department of Electrical & Computer Engineering  
Naval Postgraduate School  
Monterey, California
8. Prof. Donald Walters  
Department of Physics  
Naval Postgraduate School  
Monterey, California
9. Prof. Michael Melich  
Wayne E. Meyer Institute of Systems Engineering  
Naval Postgraduate School  
Monterey, California

10. Prof. Rod Johnson  
Wayne E. Meyer Institute of Systems Engineering  
Naval Postgraduate School  
Monterey, California
11. Prof. William Solitario  
Wayne E. Meyer Institute of Systems Engineering  
Naval Postgraduate School  
Monterey, California
12. Mr. Robert Broadston  
Department of Electrical & Computer Engineering  
Naval Postgraduate School  
Monterey, California
13. Ms. Tai Lai Poh  
Temasek Defence Systems Institute  
National University of Singapore  
Singapore