



REPLY TO  
ATTENTION OF

DEPARTMENT OF THE ARMY  
US ARMY DEFENSE AMMUNITION CENTER  
1 C TREE ROAD  
MCALESTER, OK 74501-9053

SJMAC-DEV (70-1pp)

6 February 2007

MEMORANDUM FOR SEE DISTRIBUTION

SUBJECT: Report No. 06-04A1, "Transportability Testing of the Joint Modular Intermodal Platform (JMIP)", TP-94-01, "Transportability Testing Procedures"

1. Enclosed please find subject report dated November 2006.
2. The POC is the undersigned, SJMAC-DEV, DSN 956-8908.

FOR THE DIRECTOR:

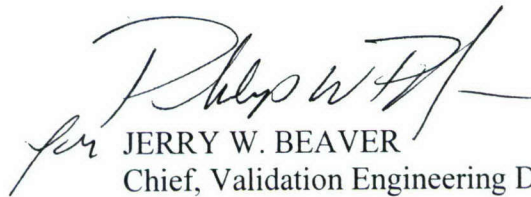
  
for JERRY W. BEAVER  
Chief, Validation Engineering Division

Encl  
as

DISTRIBUTION:

Commander,  
Transportation Engineering Agency (MTTE-DPE) Mr. Lloyd Cato, Military Traffic  
Management Command, 720 Thimble Shoals Blvd, Suite 130, Newport News, VA 23606-2574  
ARDEC Logistics Research & Engineering Directorate (AMSRD-AAR-AIL-P) Al Galonski,  
Bldg 455, Picatinny Arsenal, NJ 07806-5001  
ARDEC Logistics Research & Engineering Directorate (AMSRD-AAR-AIL-F) Tom Sieffert,  
Picatinny Arsenal, NJ 07806-5001  
U.S. Army Joint Munitions Command (AMSJM-TT) Richard Nesbitt, Rock Island, IL  
61299-6000  
ARDEC Logistics Research & Engineering Directorate (AMSRD-AAR-AIL-P-(R))  
Dave Piskorik, Rock Island, IL 61299-7300  
U.S. Army Aviation & Missile Command (AMSAM-MMC-MM-DT), Redstone Arsenal, AL  
35898-5070  
U.S. Army Materiel Command (AMSAM-LG), 5001 Eisenhower Avenue, Alexandria, VA  
22333-0001

(CONT)

SJMAC-DEV

SUBJECT: Report No. Report No. 06-04A1, "Transportability Testing of the Joint Modular Intermodal Platform (JMIP)", TP-94-01, "Transportability Testing Procedures"

DISTRIBUTION (CONT):

Director,

✓ Defense Technical Information Center, 8725 John J. Kingman Road, Suite 0944, Fort Belvoir,  
VA 22060-6218

Commandant,

U.S. Army Ordnance Missile & Munitions Center & School

(ATSK-CMT-Z), James Kisner, Redstone Arsenal, AL 35897-6095

U.S. Army Transportation School (ATSP-CDT), Fort Eustis, VA 23604

**FINAL REPORT  
NOVEMBER 2006**

**REPORT NO. 06-04A1**



**TRANSPORTABILITY TESTING OF THE JOINT MODULAR  
INTERMODAL PLATFORM (JMIP)  
TP-94-01,  
“TRANSPORTABILITY TESTING PROCEDURES”**

Prepared for:

Distribution Unlimited:

TACOM/ ARDEC  
Logistics Research and Development Activity  
ATTN: AMSRD-AAR-AIL-F  
Picatinny Arsenal, NJ 07806



**DEFENSE AMMUNITION CENTER  
VALIDATION ENGINEERING DIVISION  
MCALESTER, OKLAHOMA 74501-9053**

## **AVAILABILITY NOTICE**

A copy of this report will be furnished each attendee on automatic distribution. Additional copies or authority for reprinting may be obtained by written request from:

Director  
U.S. Army Defense Ammunition Center  
ATTN: SJMAC-DEV  
1 C Tree Road, Bldg. 35  
McAlester, OK 74501-9053

## **DISTRIBUTION INSTRUCTIONS**

Destroy this report when no longer needed. Do not return.

\*\*\*

Citation of trade names in this report does not constitute an official endorsement.

\*\*\*

The information contained herein will not be used for advertising purposes.

**TRANSPORTABILITY TESTING OF THE  
JOINT MODULAR INTERMODAL PLATFORM (JMIP)  
TP-94-01, REV. 2, JUNE 2004, "TRANSPORTABILITY TESTING PROCEDURES"**

**ABSTRACT**

The U.S. Army Defense Ammunition Center (DAC), Validation Engineering Division (SJMAC-DEV), was tasked by the Logistics Research and Development Activity (AMSRD-AAR-AIL-F), Picatinny Arsenal, NJ to conduct evaluation transportability retesting on the Joint Modular Intermodal Platform (JMIP) manufactured by SEA BOX Inc, East Riverton, NJ. The testing was conducted in accordance with TP-94-01, Revision 2, June 2004 "Transportability Testing Procedures."

The major change on the JMIP from the unit previously tested (06-04A) was that the container restraint mechanisms were changed to cams which are pinned in position. The restraint mechanisms are no longer the retractable arms as previously tested.

The objective of the testing was to evaluate the JMIP when transportability tested in accordance with TP-94-01, Revision 2, June 2004 for use during the Limited Military Utility Assessment (LMUA).

The following observations resulted from the testing of JMIP:

1. Prior to testing, the pins holding the rear roller assemblies bent.
2. The nuts holding the pins which supported the A-frame in the container transport position were damaged which was a result of picking up the loaded JMIP using the PLS truck and having the JMIP A-frame in the container transport position and not the PLS position. The nuts and bolts were replaced and rewelded prior to

testing. Clarification needs to be provided on the JMIP to easily identify that the A-frame is in the proper position.

3. The JMIP rear bumper pads were attached with adhesive only. One bumper pad fell off prior to testing.

4. The rails at the front of the JMIP did not rest on the PLS truck supports (frog feet).

5. During transport in the intermodal container the pins holding the cams in the container shoring slot failed and deformed.

The following conclusions resulted from the testing of JMIP:

1. Care must be taken to verify that the A-frame locking pins are properly engaged when the JMIP is picked up with a load handling system.

2. The JMIP, as currently designed, is adequate to be used to transport the Navy JMIP containers with ammunition, on/off road, using a Load Handling System equipped vehicle during the Limited Military Utility Assessment (LMUA).

(Example – PLS truck)

3. The maximum gross weight (platform and payload weight) is not to exceed 15,000 pounds during the LMUA.

4. The JMIP, as currently designed, is **not adequate**, for the transportation of ammunition in an intermodal container.

Prepared by:

Reviewed by:

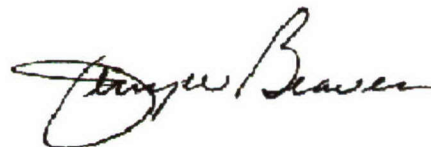
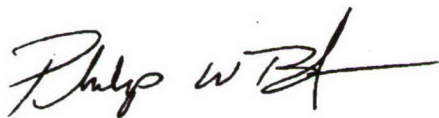

PHILIP W. BARICKMAN  
Lead Validation Engineer

JERRY W. BEAVER  
Chief, Validation Engineering Division

**U.S. ARMY DEFENSE AMMUNITION CENTER**

VALIDATION ENGINEERING DIVISION  
MCALESTER, OK 74501-9053

**REPORT NO. 06-04A1**

**Transportability Testing of the Joint Modular Intermodal Platform (JMIP)  
TP-94-01, Revision 2, June 2004 "Transportability Testing Procedures"**

TABLE OF CONTENTS

PART	PAGE NO.
1. INTRODUCTION .....	1-1
A. BACKGROUND .....	1-1
B. AUTHORITY .....	1-1
C. OBJECTIVE .....	1-1
D. OBSERVATIONS.....	1-1
E. CONCLUSION .....	1-2
2. ATTENDEES .....	2-1
3. TEST EQUIPMENT .....	3-1
4. TEST PROCEDURES .....	4-1
A. RAIL TEST .....	4-1
B. ON/OFF ROAD TESTS .....	4-3
1. HAZARD COURSE.....	4-3
2. ROAD TRIP .....	4-4
3. PANIC STOPS.....	4-4
4. WASHBOARD COURSE .....	4-4
C. OCEAN-GOING VESSEL TEST. Shipboard Trans. Simulator .....	4-4
5. TEST RESULTS .....	5-1
5.1 TESTING DATE –22 August 2006.....	5-1
A. ON/OFF ROAD TESTS .....	5-3
1. HAZARD COURSE .....	5-3
2. ROAD TRIP .....	5-4
3. PANIC STOPS.....	5-4
4. HAZARD COURSE .....	5-4
5. WASHBOARD COURSE .....	5-4
B. OBSERVATION.....	5-5
C. CONCLUSION .....	5-5

5.2 TESTING DATE –23 August 2006.....	5-6
A. ON/OFF ROAD TESTS .....	5-7
1. HAZARD COURSE .....	5-7
B. OBSERVATIONS .....	5-8
C. CONCLUSION .....	5-8
5.3 TESTING DATE –23 August 2006.....	5-9
A. ON/OFF ROAD TESTS .....	5-10
1. HAZARD COURSE .....	5-10
B. OBSERVATION.....	5-11
C. CONCLUSION .....	5-11
6. DRAWINGS .....	6-1

## **PART 1 – INTRODUCTION**

**A. BACKGROUND.** The U.S. Army Defense Ammunition Center (DAC), Validation Engineering Division (SJMAC-DEV), was tasked by the Logistics Research and Development Activity (AMSRD-AAR-AIL-F), Picatinny Arsenal, NJ to conduct transportability retesting on the Joint Modular Intermodal Platform (JMIP) manufactured by SEA BOX Inc, East Riverton, NJ. The testing was conducted in accordance with TP-94-01, Revision 2, June 2004, “Transportability Testing Procedures.”

The major change on the JMIP from the unit previously tested (06-04A), was that the container restraint mechanisms were changed from retractable arms to cams which are pinned in position.

**B. AUTHORITY.** This test was conducted IAW mission responsibilities delegated by the U.S. Army Joint Munitions Command (JMC), Rock Island, IL. Reference is made to the following:

1. AR 740-1, 15 June 2001, Storage and Supply Activity Operation.
2. OSC-R, 10-23, Mission and Major Functions of U.S. Army Defense Ammunition Center (DAC) 21 Nov 2000.

**C. OBJECTIVE.** The objective of the testing was to evaluate the Joint Modular Intermodal Platform (JMIP) when transportability tested in accordance with TP-94-01, Revision 2, June 2004 for use during the Limited Military Utility Assessment (LMUA).

**D. OBSERVATIONS.**

1. Prior to testing the pins holding the rear roller assemblies bent.
2. The nuts holding the pins which supported the A-frame in the container transport position were damaged which was a result of picking up the loaded JMIP using the PLS truck and having the JMIP A-frame in the container transport position

and not the PLS position. The nuts and bolts were replaced and rewelded prior to testing. Clarification needs to be provided on the JMIP to easily identify that the A-frame is in the proper position.

3. The JMIP rear bumper pads were attached with adhesive only. One bumper pad fell off prior to testing.

4. The rails at the front of the JMIP did not rest on the PLS truck supports (frog feet).

5. During transport in the intermodal container the pins holding the cams in the container shoring slot failed and deformed.

#### **E. CONCLUSION.**

1. Care must be taken to verify that the A-frame locking pins are properly engaged when the JMIP is picked up with a load handling system.

2. The JMIP. As currently designed, is adequate to be used to transport the Navy JMIP containers with ammunition, on/off road, using a Load Handling System equipped vehicle during the Limited Military Utility Assessment (LMUA).  
(Example – PLS truck)

3. The maximum gross weight (platform and payload weight) is not to exceed 15,000 pounds during the LMUA.

4. The JMIP, as currently designed, is **not adequate**, for the transportation of ammunition in an intermodal container.

## PART 2 - ATTENDEES

### ATTENDEE

### MAILING ADDRESS

Philip Barickman  
DSN 956-8992  
(918) 420-8992

Director  
U.S. Army Defense Ammunition Center  
ATTN: SJMAC-DEV  
1 C Tree Road, Bldg. 35  
McAlester, OK 74501-9053

Michael S. Bartosiak  
DSN 956-8083  
(918) 420-8083

Director  
U.S. Army Defense Ammunition Center  
ATTN: SJMAC-DET  
1 C Tree Road, Bldg. 35  
McAlester, OK 74501-9053

Richard Garside  
DSN 956-8050  
(918) 420-8050

Director  
U.S. Army Defense Ammunition Center  
ATTN: SJMAC-DET  
1 C Tree Road, Bldg. 35  
McAlester, OK 74501-9053

Tom Sieffert  
(973) 724-7446

U.S. Army Armament Research,  
Development and Engineering Center  
Logistics Research & Engineering Dir.  
ATTN: AMSRD-AAR-AIL-F  
Picatinny Arsenal, NJ 07806-5001

### **PART 3 - TEST EQUIPMENT**

1. Joint Modular Intermodal Platform  
Manufactured by SEA BOX, East Riverton, NJ  
Model Number: J-MIP LN702  
Serial Number: 00002  
Date of Manufacture: 27 February 2006  
Tare Weight: 3,960 pounds
  
2. Joint Modular Intermodal Container  
Manufactured by British Aerospace Engineering  
Weight: 310 pounds  
Length: 51-3/4 inches  
Width: 43-3/4 inches  
Height: 43-1/4 inches
  
3. Joint Modular Intermodal Container  
Manufactured by Naval PHST Center - Earle, NJ  
Closed JMIC  
Weight: 325 pounds  
Length: 51-3/4 inches  
Width: 43-3/4 inches  
Height: 43 inches
  
4. Joint Modular Intermodal Container  
Manufactured by Naval PHST Center – Earle, NJ  
Open Framed JMIC  
Weight: 285 pounds  
Length: 51-3/4 inches  
Width: 43-3/4 inches  
Height: 43 inches

5. Palletized Load System Truck

Model #: M1074

Manufactured by Oshkosh Truck Corporation, Oshkosh, WI

ID #: 10T2P1NH6N1044011

NSN: 2320-01-304-2277

Serial #: 44011

Curb Weight: 55,000 pounds

6. Truck, Tractor, MTV, M1088 A1

ID #: J0231

NSN: 2320 01 447 3893

VSN: NL1FR5

MFG Serial #: T-018447EFJM

Weight: 19,340 pounds

7. Semitrailer, flatbed, breakbulk/container transporter, 34 ton

Model #: M872A1

Manufactured by Heller Truck Body Corporation, Hillsdale, NJ

ID #: 11-1505 NX05NZ

NSN: 2330 01 109 8006

Weight: 19,240 pounds

8. Intermodal Container

ID # CMCU 200006-8

Date of Manufacture: 06/99

Manufactured by Charleston Marine Containers, Charleston, SC

Tare Weight: 4,870 pounds

Maximum Gross Weight: 67,200 pounds

## **PART 4 - TEST PROCEDURES**

The test procedures outlined in this section were extracted from TP-94-01, "Transportability Testing Procedures," Revision 2, June 2004, for validating tactical vehicles and outloading procedures used for shipping munitions by tactical truck, railcar, and ocean-going vessel.

The rail impact will be conducted with the loaded intermodal container secured directly to the railcar. Inert (non-explosive) items were used to build the load. The test loads were prepared using the blocking and bracing procedures proposed for use with munitions (**see Part 6- Drawings for procedures**). The weight and physical characteristics (weights, physical dimensions, center of gravity, etc.) of the test loads were similar to live (explosive) ammunition.

**A. RAIL TEST. RAIL IMPACT TEST METHOD.** The test load or vehicle will be secured to a flatcar. The equipment needed to perform the test will include the specimen (hammer) car, four empty railroad cars connected together to serve as the anvil, and a railroad locomotive. The anvil cars will be positioned on a level section of track with air and hand brakes set and with draft gears compressed. The locomotive unit will push the specimen car toward the anvil at a predetermined speed, then disconnect from the specimen car approximately 50 yards away from the anvil cars allowing the specimen car to roll freely along the track until it strikes the anvil. This will constitute an impact. Impacting will be accomplished at speeds of 4, 6, and 8.1 mph in one direction and at a speed of 8.1 mph in the reverse direction. The tolerance for the speeds is plus 0.5 mph, minus 0.5 mph for the 4 mph and 6 mph impacts, and plus 0.5 mph, minus 0 mph for the 8.1 mph impacts. The impact speeds will be determined by using an electronic counter to measure the time for the specimen car to traverse an 11-foot distance immediately prior to contact with the anvil cars (see Figure 1).

# ASSOCIATION OF AMERICAN RAILROADS (AAR)

## STANDARD TEST PLAN

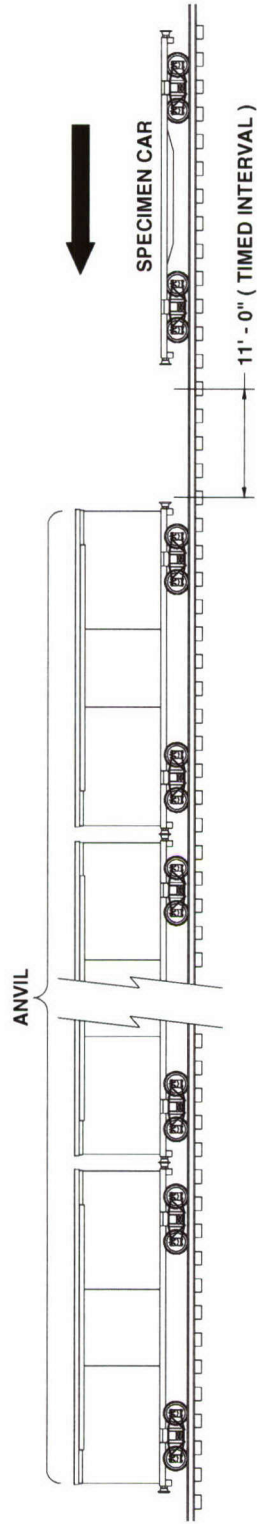

4 BUFFER CARS (ANVIL)  
WITH DRAFT GEAR  
COMPRESSED AND AIR BRAKES IN A SET  
POSITION

ANVIL CAR TOTAL WT. 250,000 LBS (APPROX)

SPECIMEN CAR IS RELEASED BY SWITCH ENGINE  
TO

ATTAIN: IMPACT NO. 1 @ 4 MPH

IMPACT NO. 2 @ 6 MPH

IMPACT NO. 3 @ 8.1 MPH

THEN THE CAR IS REVERSED AND RELEASED BY  
SWITCH ENGINE TO ATTAIN:

IMPACT NO. 4 @ 8.1 MPH

Figure 1. Rail Impact Sketch

**B. ON/OFF ROAD TEST.**

**1. HAZARD COURSE.** The test load or vehicle will be transported over the 200-foot-long segment of concrete-paved road consisting of two series of railroad ties projecting 6 inches above the level of the road surface. The hazard course will be traversed two times (see Figure 2).

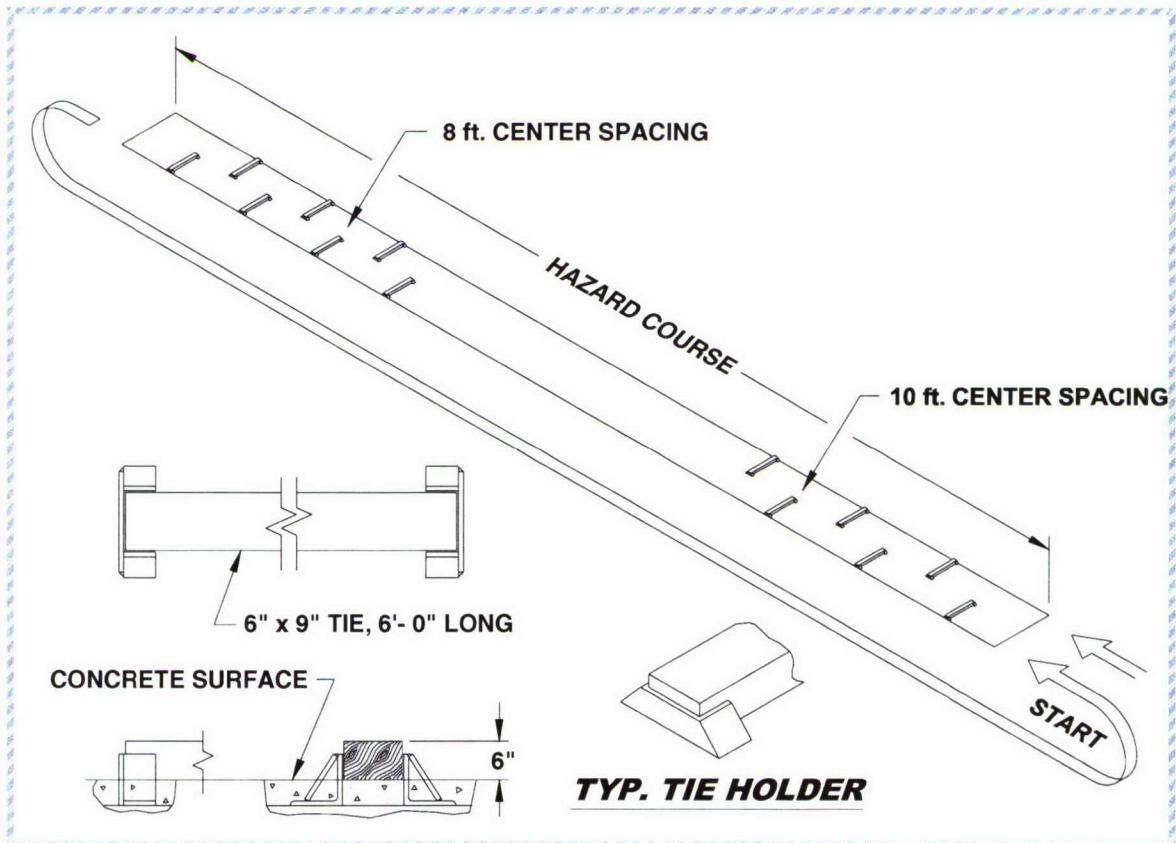

**Figure 2. Hazard Course Sketch**

a. The first series of 6 ties are spaced on 10-foot centers and alternately positioned on opposite sides of the road centerline for a distance of 50 feet.

b. Following the first series of ties, a paved roadway of 75 feet separates the first and second series of railroad ties.

c. The second series of 7 ties are spaced on 8-foot centers and alternately positioned on opposite sides of the road centerline for a distance of 48 feet.

d. The test load is driven across the hazard course at speeds that will produce the most violent vertical and side-to-side rolling reaction obtainable in traversing the hazard course (approximately 5 mph).

**2. ROAD TRIP.** The test load or vehicle will be transported for a distance of 30 miles over a combination of roads surfaced with gravel, concrete, and asphalt. The test route will include curves, corners, railroad crossings and stops and starts. The test load or vehicle will travel at the maximum speed for the particular road being traversed, except as limited by legal restrictions.

**3. PANIC STOPS.** During the road trip, the test load or vehicle will be subjected to three (3) full airbrake stops while traveling in the forward direction and one in the reverse direction while traveling down a 7 percent grade. The first three stops are at 5, 10, and 15 mph while the stop in the reverse direction is approximately 5 mph. This testing will not be required if the Rail Impact Test is performed.

**4. WASHBOARD COURSE.** The test load or vehicle will be driven over the washboard course at a speed that produces the most violent response in the vertical direction.

**C. OCEAN-GOING VESSEL TEST. Shipboard Transportation Simulator (Test Method 5).** The Shipboard Transportation Simulator (STS) is used for testing loads in 8-foot-wide by 20-foot-long intermodal freight containers. The specimen shall be positioned onto the STS and securely locked in place using the cam lock at each corner. Using the procedure detailed in the operating instructions, the STS shall begin oscillating at an angle of 30 degrees, plus or minus 2 degrees, either side of vertical center and a frequency of 2 cycles-per-

minute (30 seconds, plus or minus 2 seconds) for a duration of two (2) hours. This frequency shall be observed for apparent defects that could cause a safety hazard. The frequency of oscillation shall then be increased to 4 cycles-per-minute (15 seconds, plus or minus one second per cycle) and the apparatus operated for two (2) hours. If an inspection of the load does not indicate an impending failure, the frequency of oscillation shall be further increased to 5 cycles-per-minute (12 seconds, plus or minus one second per cycle), and the apparatus operated for four (4) hours. The operation does not necessarily have to be continuous; however, no changes or adjustments to the load or load restraints shall be permitted at any time during the test. After once being set in place, the test load (specimen) shall not be removed from the apparatus until the test has been completed or is terminated.

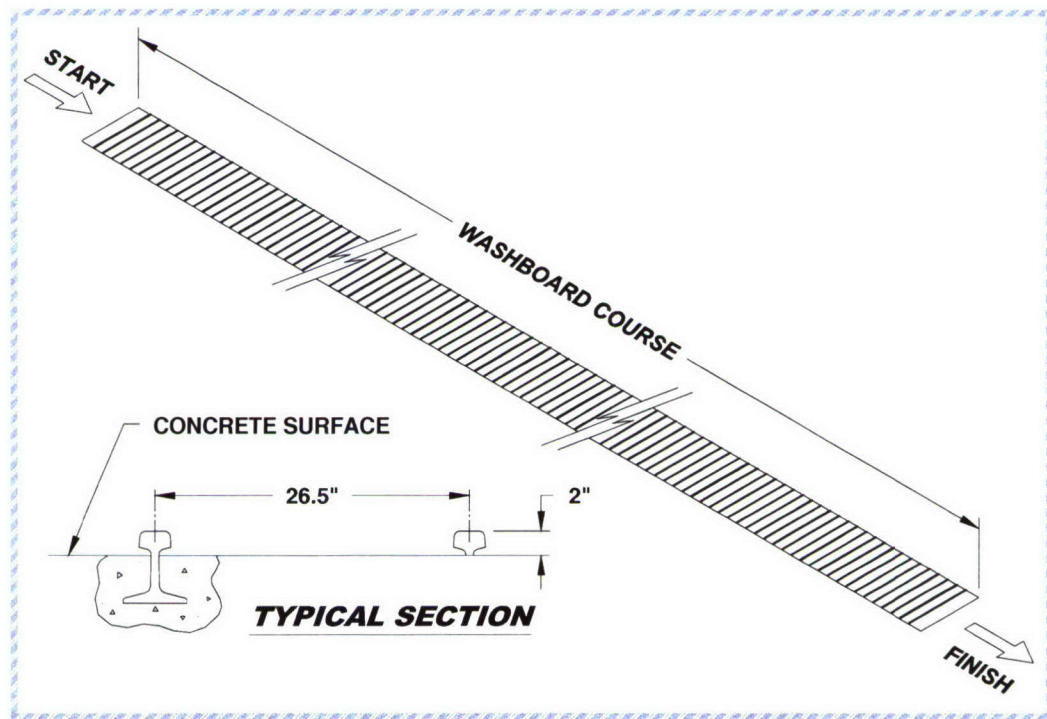

Figure 3. Washboard Course Sketch

## PART 5 - TEST RESULTS

### 5.1

Test Specimen: SEA BOX JMIP on the PLS Truck

Payload: 4 BAE JMICs and 2 Navy JMICs.

Testing Date: 22 August 2006

Gross Weight: 15,480 pounds (Including JMIP, interface frames and JMICs).

#### Notes:

1. Prior to the start of testing, the pins holding the wheels in position bent.



**Photo 1. Bent Roller Pin**

2. The nuts holding the pins which supported the A-frame in the container transport position were damaged which was a result of picking up the loaded JMIP using the PLS truck and having the JMIP A-frame in the container transport position and not the PLS position. The nuts and bolts were replaced and rewelded prior to testing. Clarification needs to be provided on the JMIP to easily identify that the A-frame is in the proper lifting position.

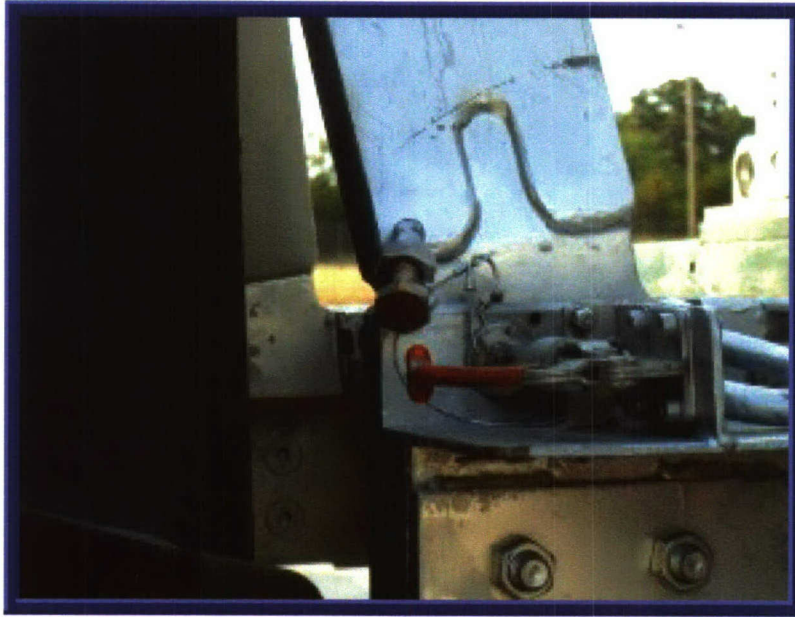

**Photo 2. Damaged Container Transport Nut.**

3. The JMIP rear bumper pads were attached with adhesive only. One bumper pad fell off prior to testing.

4. When on the PLS truck, the rails at the front of the JMIP did not rest on the support (frog feet) of the PLS truck. The base of the JMIP, between the main rails, rested on the PLS load handling system.

**A. ON/OFF ROAD TESTS.**

**1. HAZARD COURSE.**



**Photo 3. Hazard Course Testing of the SEA BOX JMIP**

<b>Pass No.</b>	<b>Elapsed Time</b>	<b>Avg. Velocity (mph)</b>
<b>1</b>	<b>21 Seconds</b>	<b>7</b>
<b>2</b>	<b>20 Seconds</b>	<b>7</b>

**Figure 4.**

**Remarks:**

1. Figure 4 lists the average speeds of the test load through the Hazard Course.
2. Inspection following Passes 1 & 2 did not reveal any damage to the JMIP.

**2. ROAD TRIP:**

**Remarks:**

1. The Road Trip was conducted between the Road Hazard Course Passes #2 and #3.
2. Inspection following the Road Trip revealed no damage or movement of the JMIP.

**3. PANIC STOPS:** Inspection following completion of each of the Panic Stops did not reveal any damage or movement of the JMIP.

**4. HAZARD COURSE:**

Pass No.	Elapsed Time	Avg. Velocity (mph)
3	22 Seconds	6
4	21 Seconds	7

Figure 5.

**Remarks:**

1. Figure 5 lists the average speeds of the test load through the Hazard Course.
2. Inspection following Passes 3 & 4 did not reveal any damage to the JMIP.

**5. WASHBOARD COURSE:**

**Remark:**

Inspection following the Washboard Course did not reveal any damage to the JMIP.



**Photo 4. Washboard Course Testing JMIP.**

**B. OBSERVATION:** Clarification needs to be provided on the JMIP to easily identify that the A-frame is in the proper lifting position. This will prevent damaging the pins/nuts from improper lifting using a load handling system when the A-frame is in the container transport position.

**C. CONCLUSION:**

1. Care must be taken to verify that the A-frame locking pins are properly engaged when the JMIP is picked up with a load handling system.
2. The JMIP, as currently designed, is adequate, to be used to transport the Navy JMIP containers with ammunition, on/off road, using a Load Handling System equipped vehicle during the Limited Military Utility Assessment (LMUA). (Example – PLS truck)
3. The maximum gross weight (platform and payload weight) is not to exceed 15,000 pounds during the LMUA.

## 5.2

Test Specimen: SEA BOX JMIP in an Intermodal Container.

Payload: 4 BAE JMICs and 2 Navy JMICs.

Testing Date: 23 August 2006

Gross Weight: 20,350 pounds (Including JMIP, interface frames, JMICs and intermodal container).

### Notes:

1. The pins used to hold the cams in the intermodal container shoring slot were not long enough to adequately restrain the cams. Also, the pins did not have any stop to prevent the pins from backing out.



**Photo 5. Pin not Properly Engaging Cam.**

2. Longer pins were substituted and were pinned on each side of the block to prevent backing out during testing.



**Photo 6. Replacement Pin.**

**A. ON/OFF ROAD TESTS.**

**1. HAZARD COURSE.**



**Photo 7. Hazard Course Testing of the JMIP in the Intermodal Container.**

Pass No.	Elapsed Time	Avg. Velocity (mph)
1	24 Seconds	6

Figure 6.

**Remarks:**

1. Figure 6 lists the average speed of the test load through the Hazard Course.
2. Inspection following the completion of Pass #1 revealed that the pin on the driver's side sheared and the cam disengaged the shoring slot.



Photo 8. Sheared Pin and Disengaged Cam

**B. OBSERVATION:** The pins used to hold the cams in position were not of sufficient strength to hold the cams in position.

**C. CONCLUSION:** The JMIP, as currently designed, is not adequate, for the transportation of ammunition in an intermodal container.

### 5.3

Test Specimen: SEA BOX JMIP in an intermodal container.

Payload: 4 BAE JMICs and 2 Navy JMICs.

Testing Date: 23 August 2006

Gross Weight: 20,350 pounds (Including JMIP, interface frames, JMICs and intermodal container).

Note: All pins used in the prior testing were replaced. The replacement pins were only pinned on the back side of the block and had a thicker diameter at the front of the block. This was done to prevent the pin from backing out during testing.



**Photo 9. Replacement Pin**

**A. ON/OFF ROAD TESTS.**

**1. HAZARD COURSE.**



**Photo 10. Hazard Course Testing of the JMIP in the Intermodal Container**

<b>Pass No.</b>	<b>Elapsed Time</b>	<b>Avg. Velocity (mph)</b>
<b>1</b>	<b>21</b>	<b>7</b>

**Figure 7.**

**Remarks:**

1. Figure 7 lists the average speeds of the test load through the Hazard Course.
2. Inspection following the completion of Pass #1 revealed that the pin on the passenger side sheared and the cams disengaged the shoring slots.

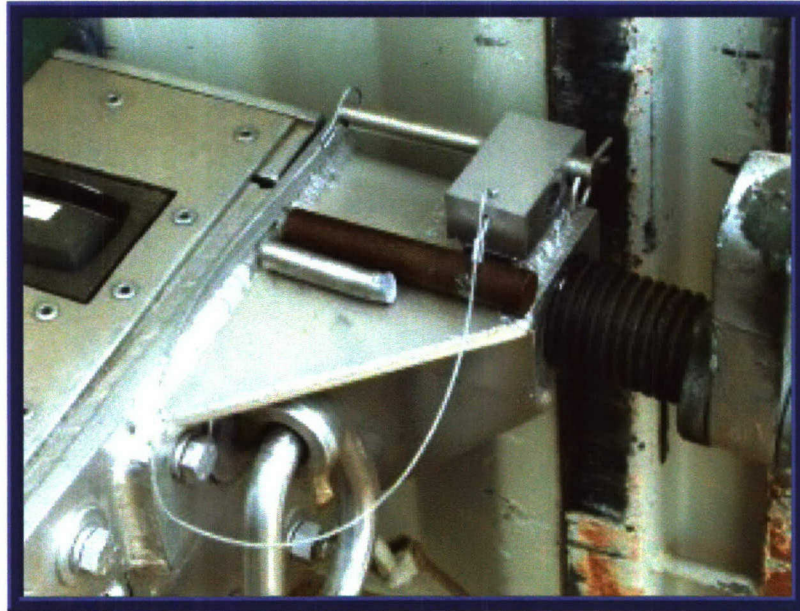

**Photo 11. Damaged Pin.**

**B. OBSERVATIONS:**

1. The pins used to hold the cams in position were not of sufficient strength to hold the cams in position.
2. The cams did not properly engage the container shoring slot. One cam would always over rotate (past 90°) in the shoring slot.

**C. CONCLUSION:** The JMIP, as currently designed, is **not adequate** for the transportation of ammunition in an intermodal container.

## **PART 6 – DRAWINGS**

The following drawing represents the load configuration that was subjected to the test criteria.

# TEST SKETCH

## **LOADING AND BRACING OF JOINT MODULAR INTERMODAL CONTAIN- ERS (JMICS) ON THE JOINT MODU- LAR INTERMODAL PLATFORM (JMIP)**

---

**THIS TEN PAGE DOCUMENT DEPICTS NAVY AND  
BAE JMIC PROTOTYPES ON A SEABOX PROTOTYPE  
JMIP FOR INTEGRATION TRANSPORTABILITY TEST-  
ING AT AN APPROXIMATE 15,000 LBS GROSS LOAD**

PREPARED DURING JULY 2006 BY:  
U.S. ARMY DEFENSE AMMUNITION CENTER  
ATTN: SJMAC-DET  
POC: MICHAEL BARTOSIAK  
DSN 956-8083  
COMM (918) 420-8083  
FAX (918) 420-8811  
E-MAIL: MICHAEL.BARTOSIAK@US.ARMY.MIL

LAURAA FIEFFER  
CHIEF, TRANSPORTATION ENGINEERING DIVISION

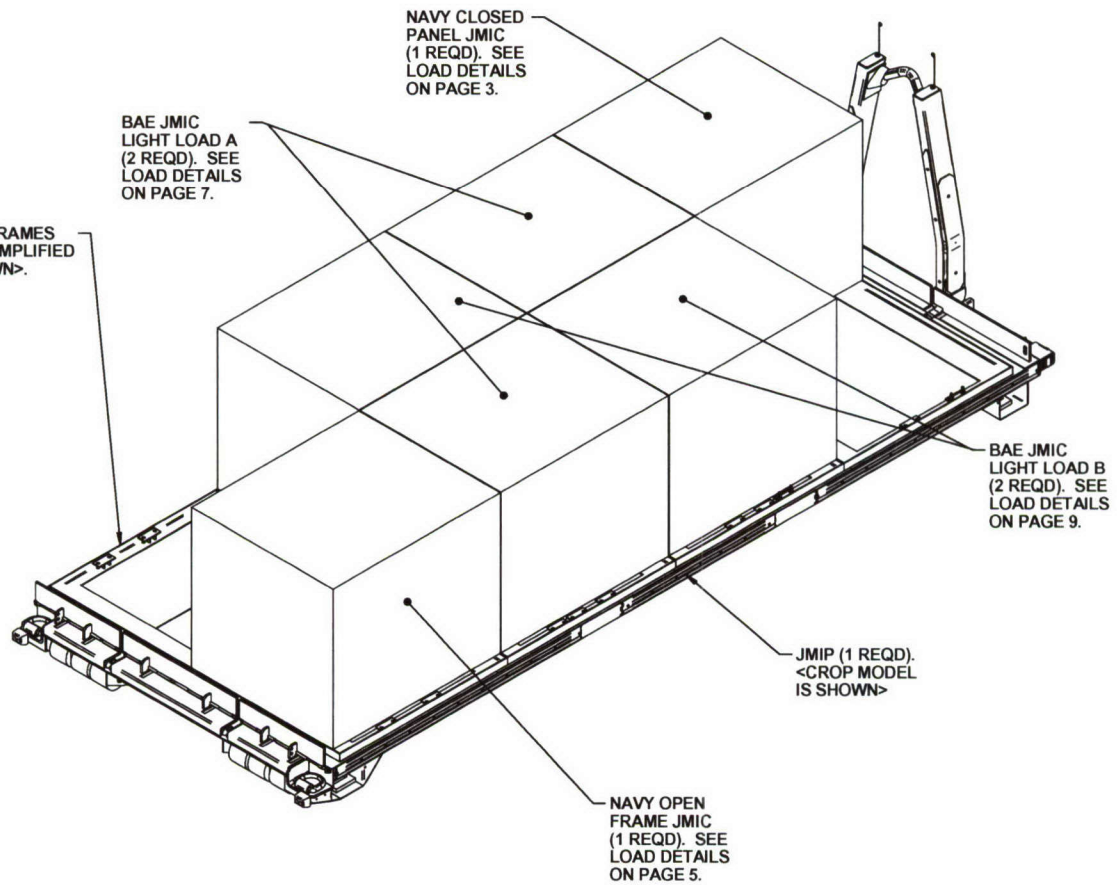

**ISOMETRIC VIEW**

**LOAD AS SHOWN**

ITEM	QUANTITY	WEIGHT (APPROX)
NAVY PANEL JMIC	1	2,971 LBS
NAVY FRAME JMIC	1	2,916 LBS
BAE JMIC (4 BOXES)	2	1,832 LBS
BAE JMIC (8 BOXES)	2	2,792 LBS
INTERFACE FRAMES	4	580 LBS
JMIP	1	3,800 LBS

TOTAL WEIGHT - - - - - 14,891 LBS (APPROX)

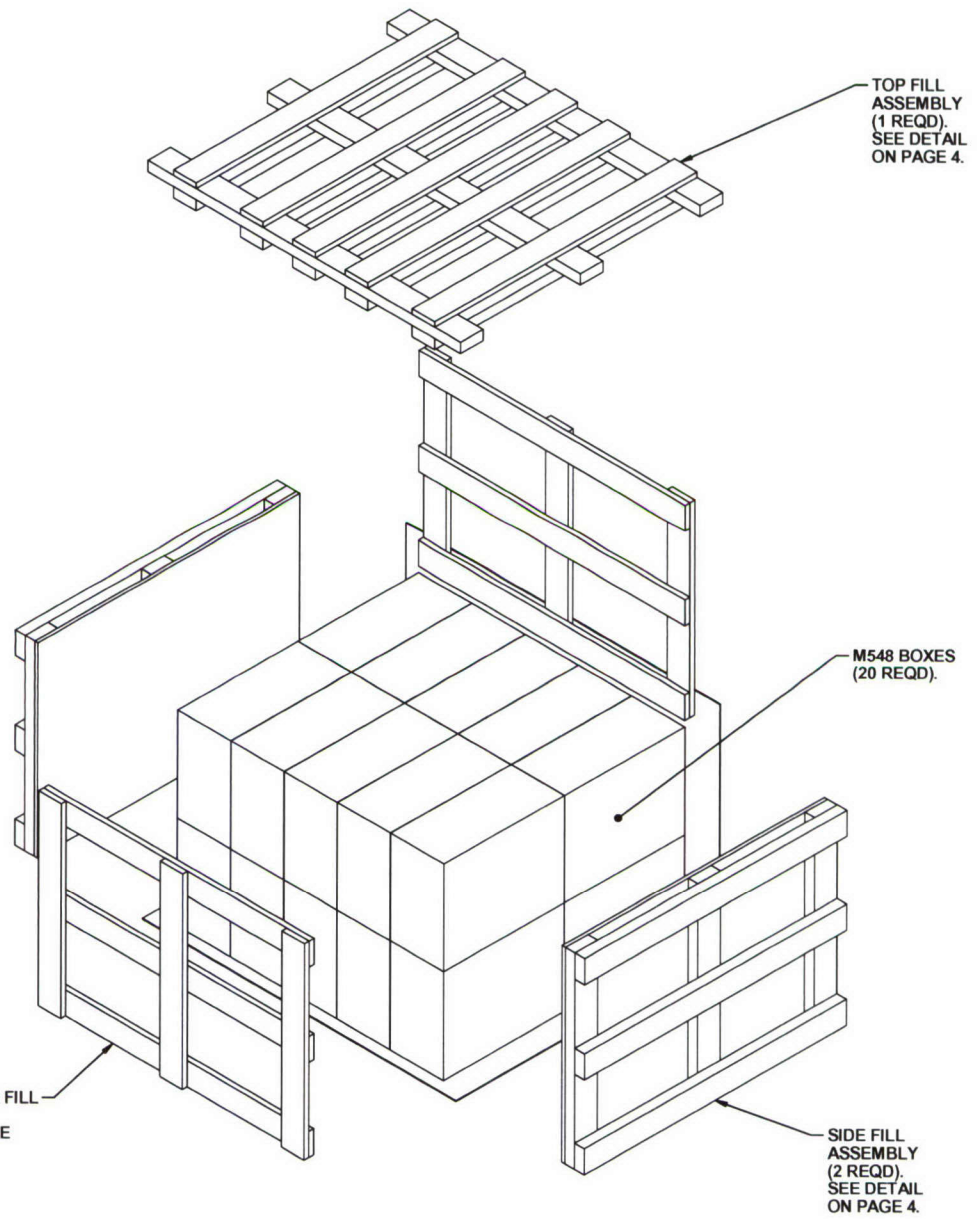

**NAVY CLOSED PANEL JMIC UNIT**

20 M548 BOXES @ 125 LBS	-----	2,500 LBS
DUNNAGE	-----	146 LBS
CLOSED PANEL NAVY JMIC	-----	325 LBS
<hr/>		
TOTAL WEIGHT	-----	2,971 LBS (APPROX)
CUBE	-----	56.4 CU FT (APPROX)

BILL OF MATERIAL		
LUMBER	LINEAR FEET	BOARD FEET
1" X 4"	52	18
2" X 4"	64	43
NAILS	NO. REQD	POUNDS
3d (1-1/4")	84	.16
6d (2")	60	.35
10d (3")	36	.54
NAVY PANEL JMIC	1 REQD	325 LBS
1/2 PLYWOOD	17 SQ FT	23 LBS

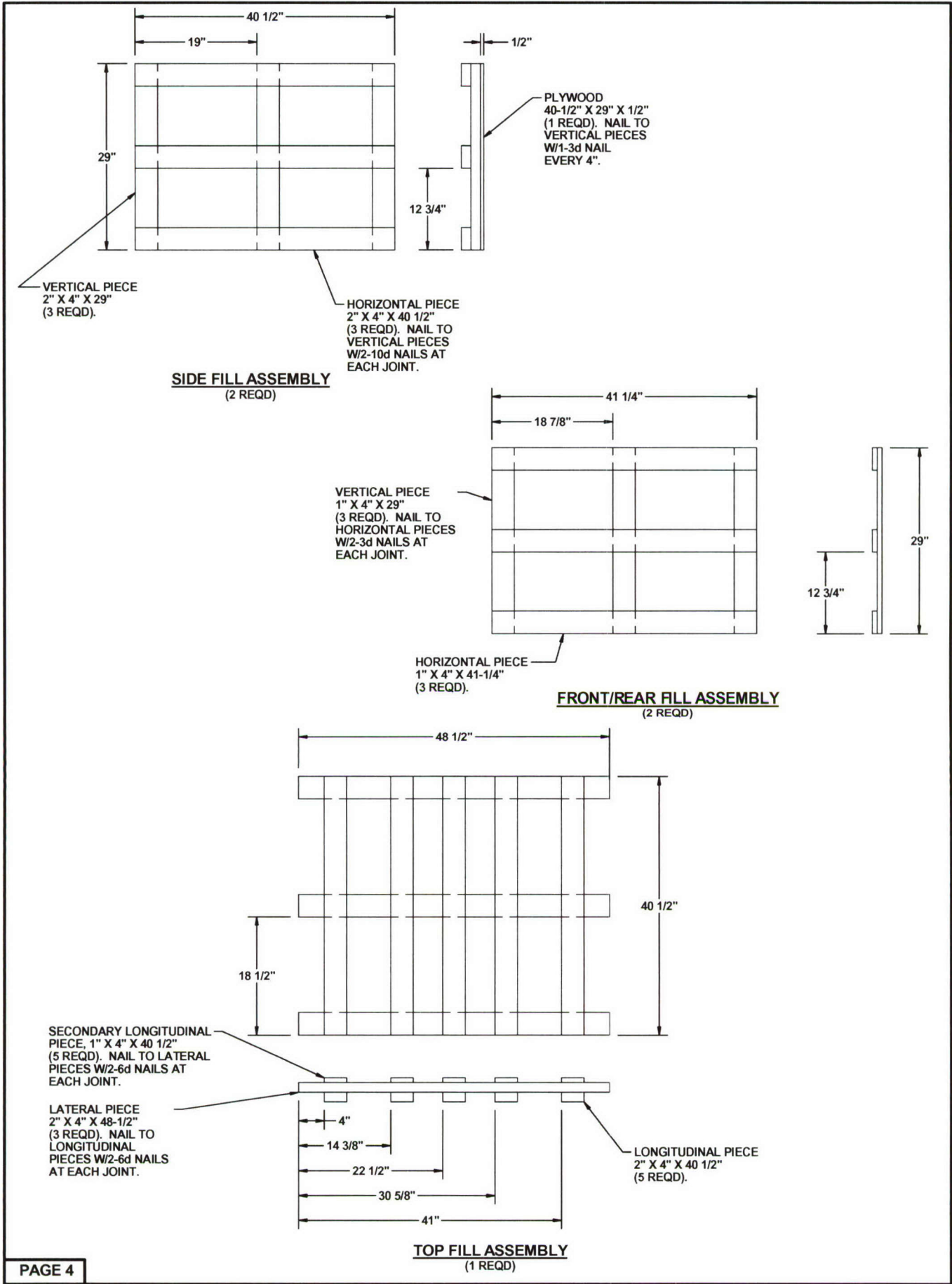

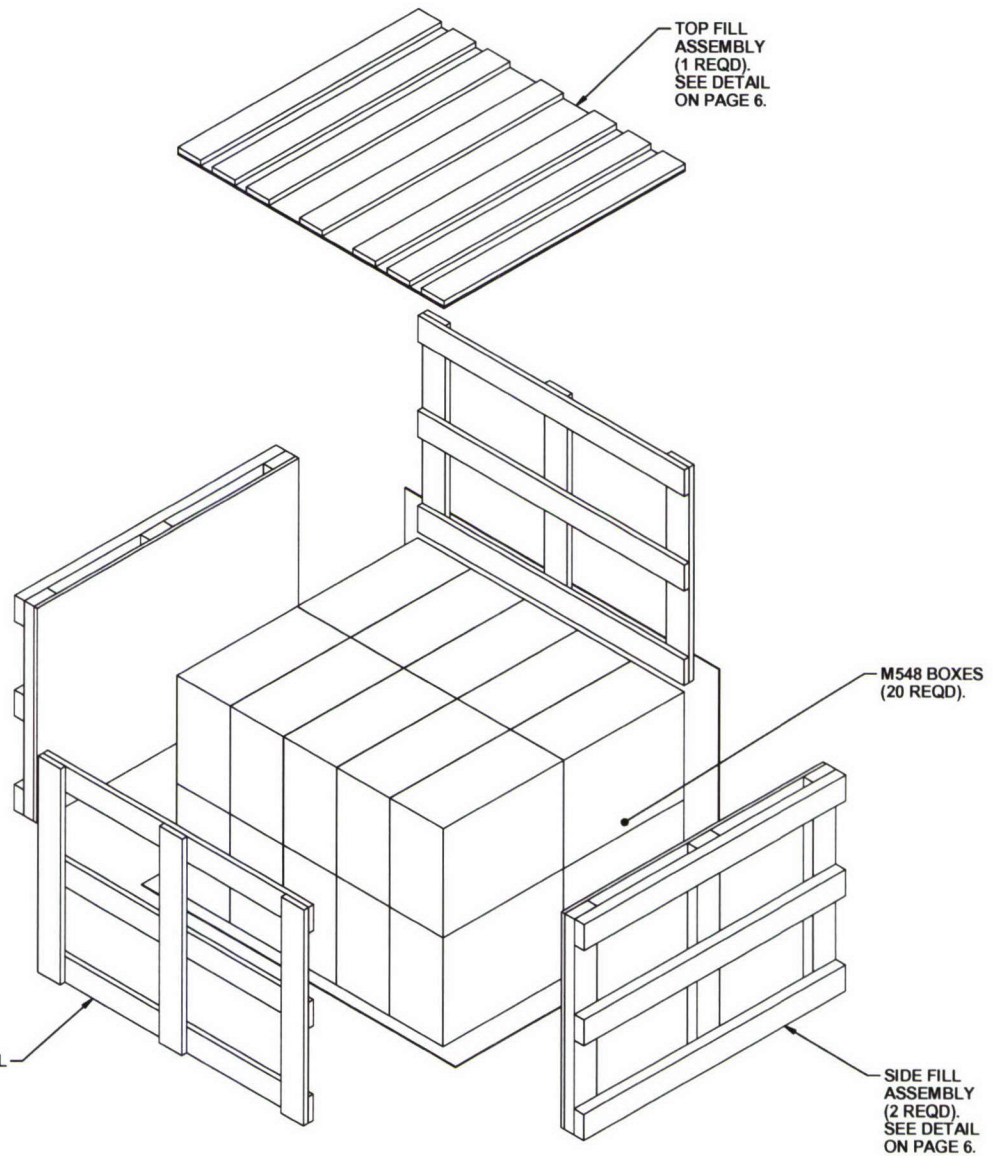

**NAVY OPEN FRAME JMIC UNIT**

STRAPPING NOT SHOWN, SEE STRAPPING DETAIL 1 & 2 ON PAGE 7 FOR FURTHER INFORMATION.

20 M548 BOXES @ 125 LBS	-----	2,500 LBS
DUNNAGE	-----	127 LBS
OPEN FRAME NAVY JMIC	-----	285 LBS

TOTAL WEIGHT ----- 2,912 LBS (APPROX)  
 CUBE ----- 56.4 CU FT (APPROX)

BILL OF MATERIAL		
LUMBER	LINEAR FEET	BOARD FEET
1" x 4"	57	19
2" x 4"	35	24
NAILS	NO. REQD	POUNDS
3d (1-1/4")	126	.23
10d (3")	36	.55
NAVY OPEN FRAME JMIC	1 REQD	285 LBS
PLYWOOD, 1/4	11 SQ FT	8 LBS
PLYWOOD, 1/2	17 SQ FT	23 LBS
STEEL STRAPPING, 1-1/4"	56' REQD	9 LBS
SEAL FOR 1-1/4" STRAPPING	4 REQD	NIL

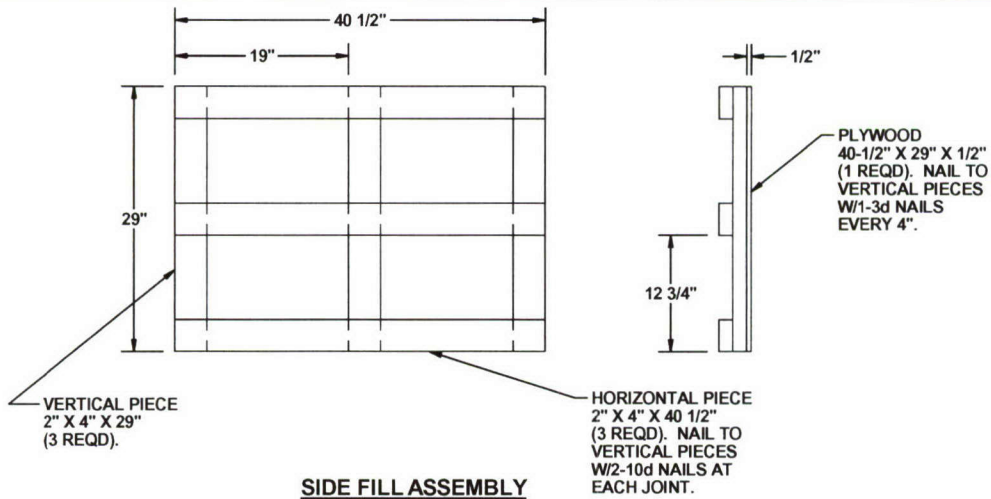

**SIDE FILL ASSEMBLY**  
(2 REQD)

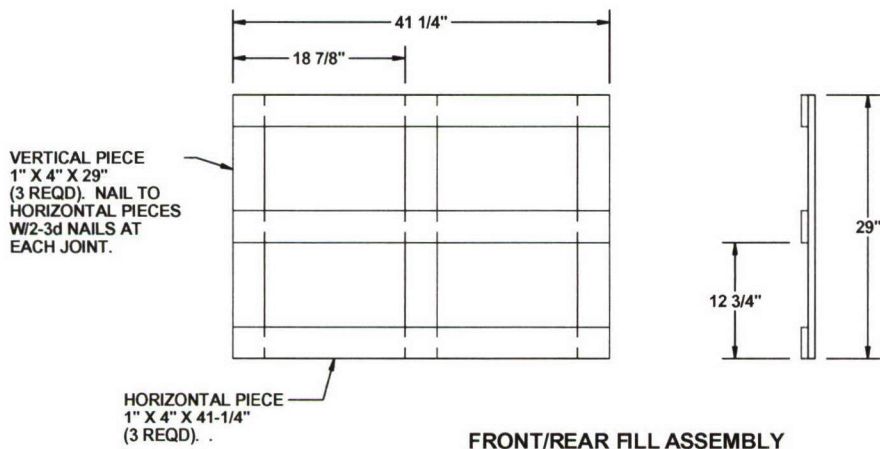

**FRONT/REAR FILL ASSEMBLY**  
(2 REQD)

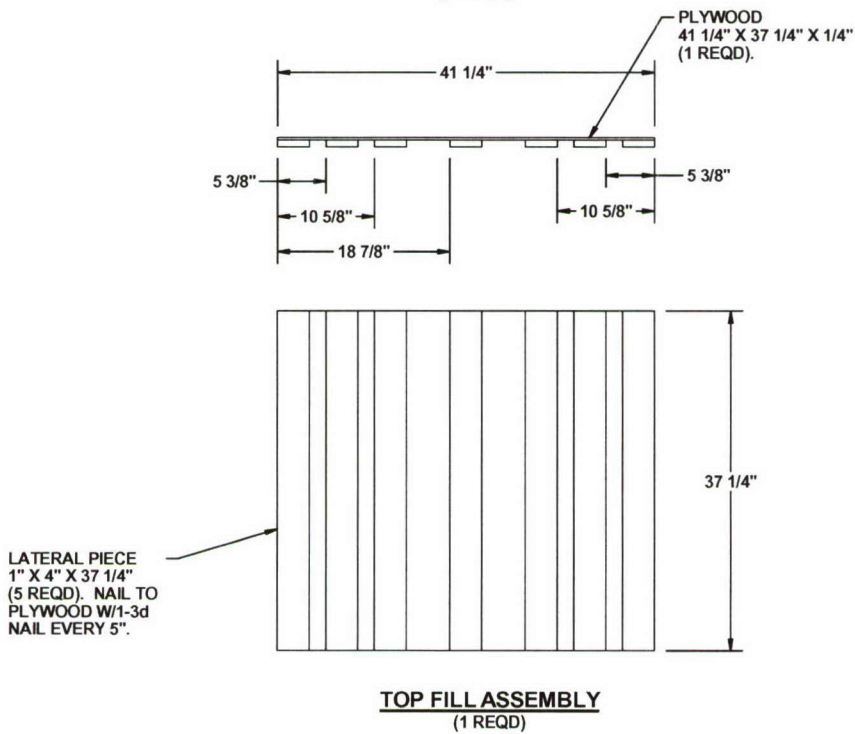

**TOP FILL ASSEMBLY**  
(1 REQD)

END FILL ASSEMBLIES  
(2 REQD). SEE END  
FILL ASSEMBLY A DETAIL  
ON PAGE 8.

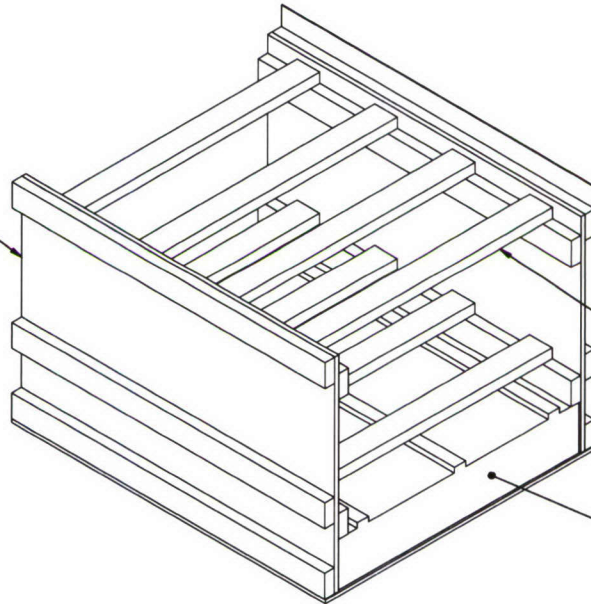

STRUTS, 2" X 4" X  
CUT TO FIT (37-11/32 REF)  
(8 REQD). NAIL TO LEDGE  
PIECES ON END FILL  
ASSEMBLIES W/2-10d NAILS  
AT EACH JOINT.

C445 WOODEN BOXES  
(4 REQD).

**BAE JMIC UNIT - LIGHT LOAD A**  
(2 REQD)

4 C445 BOXES @ 120 LBS ----- 480 LBS  
DUNNAGE ----- 126 LBS  
BAE JMIC ----- 310 LBS

TOTAL WEIGHT ----- 916 LBS (APPROX)  
CUBE ----- 56.7 CU FT (APPROX)

BILL OF MATERIAL		
LUMBER	LINEAR FEET	BOARD FEET
2" X 4"	66	44
NAILS	NO. REQD	POUNDS
6d (2")	60	.35
10d (3")	32	.48
BAE JMIC ----- 1 REQD -----		310 LBS
5/8 PLYWOOD ----- 22 SQ FT -----		37 LBS

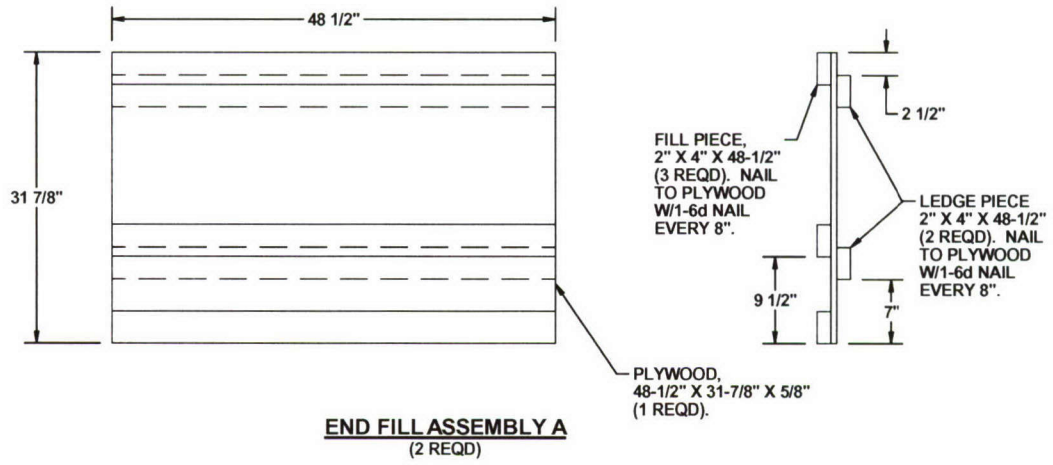

END FILL ASSEMBLIES  
(2 REQD). SEE END  
FILL ASSEMBLY B DETAIL  
ON PAGE 10.

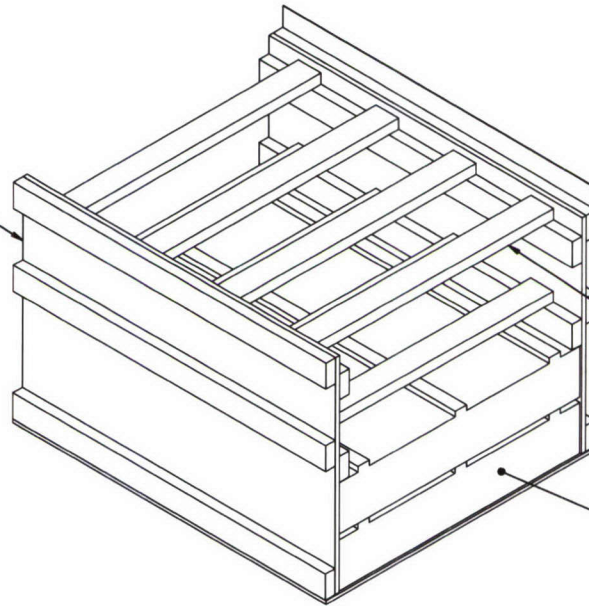

STRUTS, 2" X 4" X  
CUT TO FIT (37-11/32 REF)  
(8 REQD). NAIL TO LEDGE  
PIECES ON END FILL  
ASSEMBLIES W/2-10d NAILS  
AT EACH JOINT.

C445 WOODEN BOXES  
(8 REQD).

**BAE JMIC UNIT - LIGHT LOAD B**  
(2 REQD)

8 C445 BOXES @ 120 LBS ----- 960 LBS  
DUNNAGE ----- 126 LBS  
BAE JMIC ----- 310 LBS

TOTAL WEIGHT ----- 1,396 LBS (APPROX)  
CUBE ----- 56.7 CU FT (APPROX)

**BILL OF MATERIAL**

LUMBER	LINEAR FEET	BOARD FEET
2" X 4"	66	44
NAILS	NO. REQD	POUNDS
6d (2")	60	.35
10d (3")	32	.48
BAE JMIC ----- 1 REQD -----		310 LBS
5/8 PLYWOOD ----- 22 SQ FT -----		37 LBS

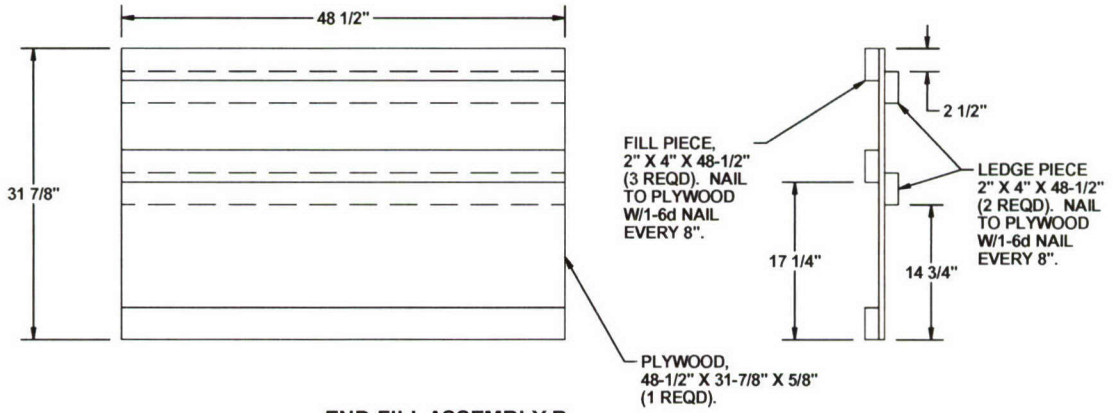

**END FILL ASSEMBLY B**  
(2 REQD)